

2011
V.1

Oklahoma State Department of Health

Ambulatory Surgery Center Data

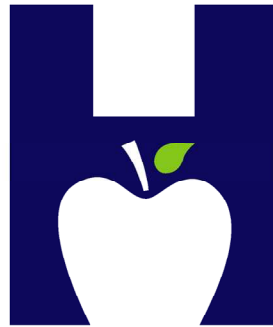

**Oklahoma State
Department of Health**

XML SUBMISSION MANUAL

1000 NE Tenth Street
Oklahoma City, OK 73117-1299
(405) 271-6225
chsadmin@health.ok.gov

AT A GLANCE:

Major changes have been made to the 2011 version of the Ambulatory Surgery Data Manual

1. **Beginning with data year 2011, a new XML format is available for data submission. In addition to the XML format, files will also be accepted in the flat file format until data year 2013 after which only the XML format will be accepted.**
2. **Medical Record Number** is added as a new required field for ambulatory surgery data.
3. More categories are added to Discharge Status to capture more discharge dispositions
4. Attending Physician Identifier has been replaced by the Referring Physician Identifier. Other Procedure physician Identifiers is added for encounters where more than surgeon is involved.
5. For physician whose NPI is not yet available or is being processed by CMS use OTH000
6. Data should be submitted through the Division's Secure Website at <https://www.phin.state.ok.us/chi-data/>.

Table of Contents

Introduction	1
Data Confidentiality	1
Data Reporting Sources and Definitions	1
Data Submission Schedule	2
Follow-up for Noncompliance	2
Secure Website Data Transfer	2
Editing and Validation	2
Facility Contacts	3
Data Transfer Format	3
TABLE 1 - Outpatient Surgery Data Elements	4
TABLE 2 – Data Elements Hierarchy	5
XML Data Record Sample	8
Description of Data Elements	11

NOTICE

This Oklahoma Ambulatory Surgery Discharge Data Reporting Manual, issued in June 2010, describes an alternate format for data submission in calendar year 2011 and forward. The XML format described in this manual will be the required format for data submission for calendar year 2013 data and forward.

If you have any questions regarding submission of this data, please contact:

Heather Hunn at (405) 271-6225 or HeatherNH@health.ok.gov

Binitha Kunnel at (405) 271-6225 or [BinthaK @ health.ok.gov](mailto:BinthaK@health.ok.gov)

If you would like to schedule a site visit at your facility, please contact HCI at (405) 271-6225 and a visit can be scheduled.

Introduction

This manual defines the data that ambulatory surgery centers are required to submit to the Division of Health Care Information of the Oklahoma State Department of Health. It specifies the technical requirements for data submission, defines the data elements to be submitted, and outlines the data editing procedure. In order to ensure the integrity of the database, data must be received in the standard format from all facilities. The Division will provide technical consultation and assistance upon request. This consultation or assistance is limited to activities that specifically enable the facility to submit data that will meet the requirements. The following sections provide a definition of the reporting source, the submission schedule, the preferred transfer method, the format and description of data elements to be transferred, and finally, information about the editing/error processing of the submitted data.

Data Confidentiality

Ambulatory surgery data furnished to the Division are considered confidential under State law and are not public records as defined by the Open Records Act, Title 51 § 24A.1 et seq. Patient identifying information will not be disclosed. It will be used only for the creation and maintenance of anonymous medical case histories for statistical analysis and reports. The Division is prohibited from identifying, either directly or indirectly, any individual in its reports. The Division will not disclose individual patient identities in any manner, except as directed by a court of competent jurisdiction after an application showing good cause.

Data Reporting Sources and Definitions

Information regarding ambulatory care services provided by ambulatory surgical centers is required to be submitted.

For each single ambulatory surgery encounter, a single data record shall be submitted. Each ambulatory surgery data record shall consist of billing, medical, and personal information describing a patient, services received by the patient, and charges billed for the patient. The specific fields required are described in detail in the Data Elements Layout and Descriptions sections. Only one ambulatory surgery data record should be submitted for each encounter. For a given patient, separate records for each bill generated should not be submitted, unless each bill represents a distinct ambulatory encounter.

A facility may submit ambulatory surgery data directly to the Division or designate a submitting intermediary. Please note that each facility is responsible for the quality and completeness of its yearly submission, regardless of the utilization of a submitting intermediary. The Division will contact the institution directly for any necessary corrections or additional information. **When an intermediary is designated, the facility must still ensure that correct information is submitted in a timely manner.** If a designated intermediary handles only a subset of a facility's encounters, then the facility must make separate arrangements to submit its other records.

For the purpose of communication and problem solving, each facility shall supply the Division with the name, telephone number, and job title of the person responsible for data submission and data corrections from each facility.

Data Submission Schedule

For each calendar year of data collected, the Division must receive all ambulatory surgery data records by March 1st following the close of that calendar year (e.g. calendar year 2011 data must be submitted by March 1, 2012). Facilities may submit on a monthly, quarterly, or semi-annual basis, if they prefer, as long as the Division is notified of their proposed schedule. **In all cases, data must be received by March 1st following each calendar year.**

The data elements to be submitted are based on encounters occurring in a calendar year. A patient must be discharged within the calendar year to be included in the calendar year data set.

Follow-Up for Non-Compliance

Submitting outpatient surgery data is required per Title 63 § 1-119. Non-compliance, including incomplete reporting of the required fields included in this manual per Permanent Rule § **310:9-3-1**, will be referred to the Oklahoma State Department of Health Medical Facilities Division for follow-up and will be published as non-compliant.

Secure Website Data Transfer

The data should be submitted through the Division's secure website. The website is accessible with a login and password. Files undergo an initial validation on submission and a validation report is available indicating any format errors. Files can be resubmitted until it passes initial validation.

The URL to the website is: <https://www.phin.state.ok.us/chi-data/>

Instructions for submitting files on the site can be obtained from the Division or is available at <https://www.phin.state.ok.us/chi-data/Instructions.pdf>

Before the deadline, the facility can resubmit the data until the file passes initial validation.

Edits and Validation

The Division will perform a variety of edits for quality assurance purposes and compliance with the specifications set forth in this submission manual. Data submissions not meeting a 2% error tolerance level will be rejected.

Table 1 gives a list of the data fields and tolerance level for each of the field. Facilities are encouraged to review the data records for accuracy and completeness corresponding to these edits criteria prior to submission.

Facility Contacts

Facilities are encouraged to provide contact information for the following individuals:

Administrator

Data submission contact

Error correction contact

Vendor contact

Corporate contact (if applicable)

Data Transfer Format

Table 1 lists the data elements and the error tolerance level for each element. Table 2 describes the hierarchy of the data elements.

The headings used under Descriptions of Data Elements are:

Descriptive Data Element Name: Names commonly used to describe the fields.

XSD Data Type: Indicates field type such as string, positive integer, and date.

Element Name: The name that needs to be used for each field in the submitted file.

Accepts Null values: This line indicates whether null values are accepted.

Required in XSD: This indicates if a field is required per the XML Schema Definition (XSD).

Minimum Constraint: Minimum number of characters allowed for the field.

Maximum Constraint: Maximum number of characters allowed for the field.

Definition: The definition specified for each data element is in general agreement with the definition specified for the field entry in the CMS-1500 form.

General Comments: Used in a similar manner as the CMS-1500 form to provide additional information and guidelines for the reporting of the data element.

Edit: The criteria used by the Division to determine acceptability of the information provided.

The data elements for each patient encounter are stored in a single record.

Table 1 – Ambulatory Surgery Center Data Elements

Data Element Name	Error Tolerance
Patient name	2%
Patient street address	-
Patient city	2%
Patient state	2%
Patient address postal code	2%
Patient date of birth	2%
Patient gender	2%
Patient last 4 digits of Social Security Number	-
Patient race	-
Patient ethnicity	-
Patient marital status	-
Patient control number	2%
Medical Record Number	-
Medicare provider number	-
Facility NPI	-
Admission date	2%
Admit hour	-
Discharge date	2%
Discharge hour	-
Patient discharge status	-
Referring physician identifier	-
Principal diagnosis	2%
Other diagnosis codes I-15	2%
Principal procedure CPT code & Modifiers	2%
Other procedure CPT codes I-5 & Modifiers	2%
Procedure physician identifier	-
Other Procedure – Physician Identifiers (I-5)	-
Principal procedure date	-
Primary Payer NPI	-
Secondary Payer NPI	-
Primary payer name	-
Secondary payer name	-
Payer classification	2%
Total charges for this encounter	2%
Facility assigned ambulatory patient classifications (APC) I-3	-

Table 2 Data Elements Hierarchy

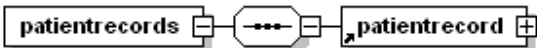
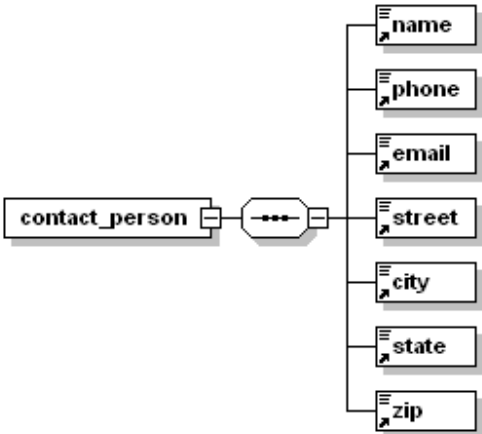
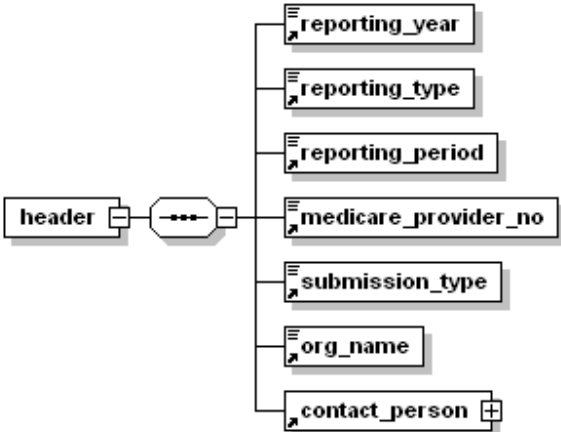
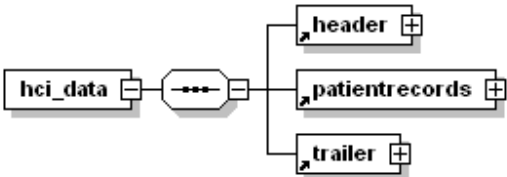

Data Elements Hierarchy Continued

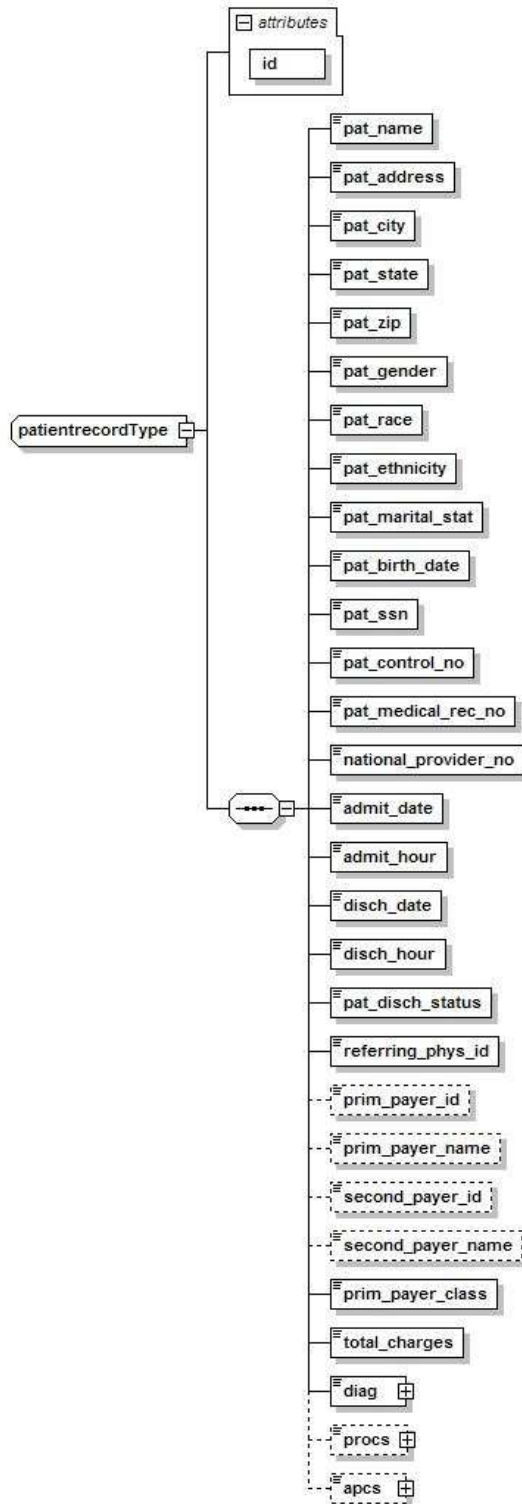

Data Elements Hierarchy Continued

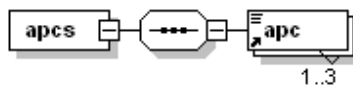
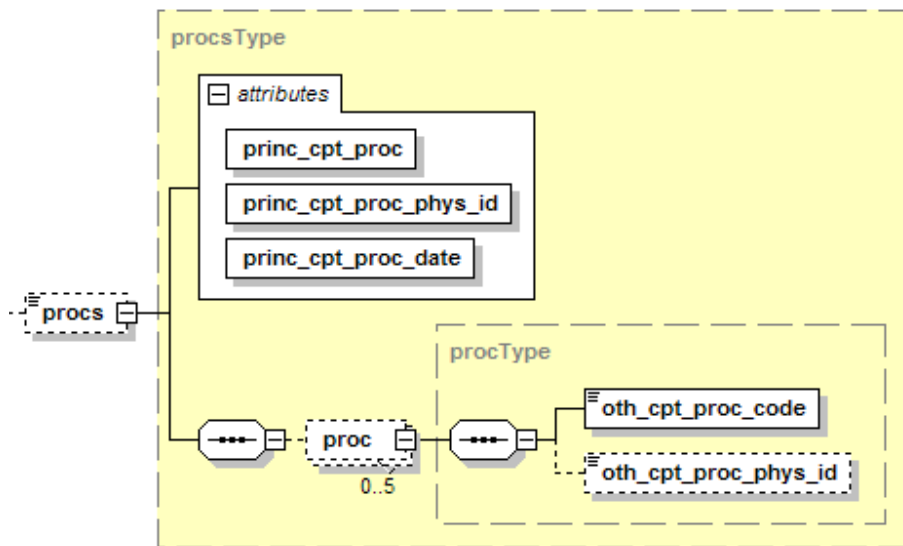
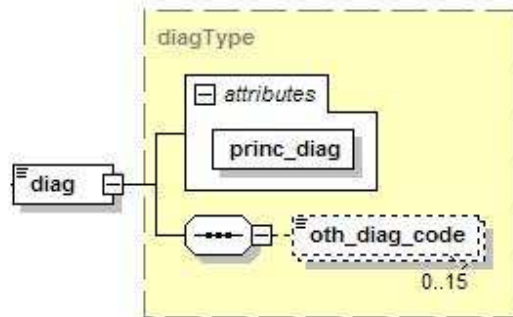

XML Data Record Sample

```
<?xml version="1.0" encoding="UTF-8" ?>
<hci_data xmlns:xsi="http://www.w3.org/2001/XMLSchema-instance"
xsi:noNamespaceSchemaLocation="http://www.health.state.ok.us/datastds/asc_schema.xsd">
  <header>
    <reporting_year>2010</reporting_year>
    <reporting_type>2</reporting_type>
    <reporting_period>1</reporting_period>
    <medicare_provider_no>123456</medicare_provider_no>
    <submission_type>A</submission_type>
    <org_name>ABC Health Center</org_name>
    <contact_person>
      <name>Contact Name</name>
      <phone>111-222-3333</phone>
      <email>webmail@ABCHealth.com</email>
      <street>Address 1 Address 2</street>
      <city>Oklahoma City</city>
      <state>OK</state>
      <zip>73000</zip>
    </contact_person>
  </header>
  <patientrecords>
    <patientrecord id="1">
      <pat_name>Doe, John</pat_name>
      <pat_address>123 Main st.</pat_address>
      <pat_city>Oklahoma City</pat_city>
      <pat_state>OK</pat_state>
      <pat_zip>73100</pat_zip>
      <pat_gender>M</pat_gender>
      <pat_race>4</pat_race>
      <pat_ethnicity>2</pat_ethnicity>
      <pat_marital_stat>S</pat_marital_stat>
      <pat_birth_date>2006-03-05</pat_birth_date>
      <pat_ssn>1234</pat_ssn>
      <pat_control_no>1236789</pat_control_no>
      <pat_medical_rec_no>456456</pat_medical_rec_no>
      <national_provider_no>1234567890</national_provider_no>
      <admit_date>2010-06-18</admit_date>
      <admit_hour>06</admit_hour>
      <disch_date>2010-06-18</disch_date>
      <disch_hour>18</disch_hour>
      <pat_disch_status>01</pat_disch_status>
      <referring_phys_id>0987654321</referring_phys_id>
      <prim_payer_id>abcde1234567890</prim_payer_id>
      <prim_payer_name>Blue Cross</prim_payer_name>
      <second_payer_id>0123456789abcde</second_payer_id>
      <second_payer_name>Medicaid</second_payer_name>
      <prim_payer_class>1</prim_payer_class>
      <total_charges>3500</total_charges>
      <diag princ_diag="47400">
```

```

        <oth_diag_code>3821</oth_diag_code>
        <oth_diag_code>78609</oth_diag_code>
    </diag>
    <procs princ_cpt_proc="42820"
princ_cpt_proc_phys_id="A123456789" princ_cpt_proc_date="2010-06-18">
        <proc>
            <oth_cpt_proc_code>6942152</oth_cpt_proc_code>
            <oth_cpt_proc_phys_id>A123456789</oth_cpt_proc_phys_id>
        </proc>
    </procs>
</patientrecord>
<patientrecord id="2">
    <pat_name>Sample, Sam</pat_name>
    <pat_address>111 First st.</pat_address>
    <pat_city>Norman</pat_city>
    <pat_state>OK</pat_state>
    <pat_zip>73090</pat_zip>
    <pat_gender>M</pat_gender>
    <pat_race>2</pat_race>
    <pat_ethnicity>2</pat_ethnicity>
    <pat_marital_stat>S</pat_marital_stat>
    <pat_birth_date>1994-09-15</pat_birth_date>
    <pat_ssn>111-22-3456</pat_ssn>
    <pat_control_no>9876543</pat_control_no>
    <pat_medical_rec_no>256455</pat_medical_rec_no>
    <national_provider_no>1234567890</national_provider_no>
    <admit_date>2010-08-20</admit_date>
    <admit_hour>16</admit_hour>
    <disch_date>2010-08-20</disch_date>
    <disch_hour>23</disch_hour>
    <pat_disch_status>01</pat_disch_status>
    <referring_phys_id>1231231238</referring_phys_id>
    <prim_payer_name>Self & Pay</prim_payer_name>
    <prim_payer_class>6</prim_payer_class>
    <total_charges>3785</total_charges>
    <diag princ_diag="81410">
        <oth_diag_code>7089</oth_diag_code>
    </diag>
    <procs princ_cpt_proc="25645" princ_cpt_proc_phys_id="987654321B"
princ_cpt_proc_date="2010-08-20" />
</patientrecord>
<patientrecord id="3">
    <pat_name>Wendell, Oliver Douglas</pat_name>
    <pat_address>100 Green Acres</pat_address>
    <pat_city>Hooterville</pat_city>
    <pat_state>OK</pat_state>
    <pat_zip>73100</pat_zip>
    <pat_gender>M</pat_gender>
    <pat_race>4</pat_race>
    <pat_ethnicity>2</pat_ethnicity>

```

```

    <pat_marital_stat>M</pat_marital_stat>
    <pat_birth_date>1940-04-27</pat_birth_date>
    <pat_ssn>111-02-3333</pat_ssn>
    <pat_control_no>1237751</pat_control_no>
    <pat_medical_rec_no>456456</pat_medical_rec_no>
    <national_provider_no>1234123490</national_provider_no>
    <admit_date>2010-10-18</admit_date>
    <admit_hour>07</admit_hour>
    <disch_date>2010-10-18</disch_date>
    <disch_hour>14</disch_hour>
    <pat_disch_status>01</pat_disch_status>
    <referring_phys_id>3217612345</referring_phys_id>
    <prim_payer_id>abcab1234567890</prim_payer_id>
    <prim_payer_name>Medicare</prim_payer_name>
    <second_payer_id>0123456999abcde</second_payer_id>
    <second_payer_name>Medicaid</second_payer_name>
    <prim_payer_class>2</prim_payer_class>
    <total_charges>2984</total_charges>
    <diag princ_diag="36610">
      <oth_diag_code>36500</oth_diag_code>
      <oth_diag_code>71509</oth_diag_code>
      <oth_diag_code>4019</oth_diag_code>
    </diag>
    <procs princ_cpt_proc="66983" princ_cpt_proc_phys_id="987612345B"
princ_cpt_proc_date="2010-10-18">
      </procs>
    </patientrecord>
  </patientrecords>
<trailer>
  <total_records>3</total_records>
</trailer>
</hci_data>

```

Description of Data Elements

Data Elements hci_data/Header

Total Elements: 6+1 (1 element has child element)

Element Name: reporting_year, reporting_type, reporting_period, medicare_provider_no, submission_type, org_name

Data Element with child element: contact person

Descriptive Data Element Name: Reporting Year

XSD Data Type: xs:string

Element Name: reporting_year

Accepts Null values: No

Required in XSD: Yes

Minimum Constraint: 4

Maximum Constraint: 4

Definition: The calendar year in which the patients were discharged.

Comments: Use the four-digit year format YYYY
E.g. 2011

Edit: A valid year must be present
Not a CMS-1500 field.

Descriptive Data Element Name: Reporting Type

XSD Data Type: xs:string

Element Name: reporting_type

Accepts Null values: No

Required in XSD: Yes

Minimum Constraint: 1

Maximum Constraint: 1

Definition: The portion of time period the data submitted will cover.

Comments: This field needs to have one of the following entries:
1 – Yearly
2 – Quarterly
3 – Monthly

Edit: Reporting type needs to be valid.
Not a CMS-1500 field.

Descriptive Data Element Name: Reporting Period

XSD Data Type: xs:string

Element Name: reporting_period

Accepts Null values: No

Required in XSD: Yes

Minimum Constraint: 1

Maximum Constraint: 2

Definition: The period for which the patients were discharged.

Comments: Complete this field, if submitting data annually, quarterly or monthly.

- Use 1 if submitting annually
- Use the following numbers for the quarter
1 for First quarter (Jan, Feb and March)
2 for Second quarter (April, May and June)
3 for third quarter (July, Aug and Sept)
4 for quarter (Oct, Nov and Dec)
- Use the following numbers for the month
1,2,3...12 to denote Jan, Feb, Mar... Dec.

If submitting multiple months or quarters a separate file for each period must be submitted.

Edit: The period needs to be valid.

Not a CMS-1500 field.

Descriptive Data Element Name: Medicare Provider Number

XSD Data Type: xs:string

Element Name: medicare_provider_no

Accepts Null values: No

Required in XSD: Yes

Minimum Constraint: 6

Maximum Constraint: 15

Definition: The number assigned to the facility by Center for Medicare and Medicaid Services. If Medicare provider number is not available, facility may use the federal tax identification number

Edit: Number must be valid.

Not a CMS-1500 field.

Descriptive Data Element Name: **Type of Data Submission**

XSD Data Type: xs: string

Element Name: submission_type

Accepts Null values: No

Required in XSD: Yes

Minimum Constraint: 1

Maximum Constraint: 1

Definition: Indicates the type of data submitted.

Comments: Use the following to indicate the type of data:

A- Ambulatory Surgery Center Data

Edit: Must be a valid entry
Not a CMS-1500 field.

Descriptive Data Element Name: **Name of the Facility**

XSD Data Type: xs: string

Element Name: org_name

Accepts Null values: No

Required in XSD: Yes

Minimum Constraint: 5

Maximum Constraint: 25

Definition: The name of the facility for which the data is submitted.

Comments: The name must be abbreviated if length more than 25 characters.

Edit: Must be a valid entry
CMS-1500 FL 32

Data Elements

contact_person

Total Elements: 7

Element Name: name, phone, email, street, city, state, zip

Descriptive Data Element Name: Name of the Data Submission Contact

XSD Data Type: xs: string

Element Name: name

Accepts Null values: No

Required in XSD: Yes

Minimum Constraint: 5

Maximum Constraint: 25

Definition: Name of the person submitting the data.

Edit: Must be a valid entry.
Not a CMS-1500 field.

Descriptive Data Element Name: Phone Number

XSD Data Type: xs: string

Element Name: phone

Accepts Null values: No

Required in XSD: Yes

Minimum Constraint: 12

Maximum Constraint: 12

Definition: Telephone number of the data submission contact.

Comments: The phone number must be in the following format:
111-222-3333

Edit: Must be a valid phone number.
Not a CMS-1500 field.

Descriptive Data Element Name: Email

XSD Data Type: xs: string

Element Name: email

Accepts Null values: No

Required in XSD: Yes

Minimum Constraint: 5

Maximum Constraint: 50

Definition: Email address of the data submission contact.

Edit: Must be a valid email address.
Not a CMS-1500 field.

Descriptive Data Element Name: Street

XSD Data Type: xs: string

Element Name: street

Accepts Null values: No

Required in XSD: Yes

Minimum Constraint: 5

Maximum Constraint: 70

Definition: The street address of the data submission contact.

Comment:

- Use mailing address if different than physical address.
- Address can be that of the facility, corporation location etc.

Edit: Must be a valid address.
Not a CMS-1500 field.

Descriptive Data Element Name: City

XSD Data Type: xs: string

Element Name: city

Accepts Null values: No

Required in XSD: Yes

Minimum Constraint: 3

Maximum Constraint: 25

Definition: The city of the data submission contact's street address.

Edit: Must be a valid city
Not a CMS-1500 field.

Descriptive Data Element Name: State

XSD Data Type: xs: string

Element Name: state

Accepts Null values: No

Required in XSD: Yes

Minimum Constraint: 2

Maximum Constraint: 2

Definition: The State of the data submission contact's address.

Comments: Use standard Post Office state abbreviations (e.g. OK for Oklahoma, TX for Texas).

Edit: State abbreviation must be present and valid
Not a CMS-1500 field.

Descriptive Data Element Name: Zip

XSD Data Type: xs: string

Element Name: zip

Accepts Null values: No

Required in XSD: Yes

Minimum Constraint: 5

Maximum Constraint: 10

Definition: The zip code of the data submission contact's address

Comments: Nine-digit zip codes are encouraged in the form XXXXX-YYYY or XXXXXYYYY

Edit: Must be a valid zip code.
Not a CMS-1500 field.

Data Elements **hci_data/patientrecords/patientrecord**

Total Attribute: 1

Total Elements: 26 + 3 (3 elements have child elements)

Attribute Name: id

Element Name: pat_name, pat_address, pat_city, pat_state, pat_zip, pat_gender, pat_race, pat_ethnicity, pat_marital_stat, pat_birth_date, pat_ssn, pat_control_no, pat_medical_rec_no, national_provider_no, admit_date, admit_hour, disch_date, discharge_hour, pat_disch_status, referring_phys_id, prim_payer_id, prim_payer_name, second_payer_id, second_payer_name, prim_payer_class, total_charges

Data Elements with child elements: diag, procs, and apcs

Descriptive Data Element Name: Sequential Record Number

XSD Data Type: xs:positiveInteger

Element Name: id

Accepts Null values: No

Required in XSD: Yes

Minimum Constraint: 1

Maximum Constraint: 6

Definition: A sequential record number generated for each record in the file beginning with one (1).

Comments: Should reflect the count of all records submitted.

Edit: Must be valid.

Not a CMS-1500 field.

Descriptive Data Element Name: Patient Name

XSD Data Type: xs:string

Element Name: pat_name

Accepts Null values: No

Required in XSD: Yes

Minimum Constraint: 2

Maximum Constraint: 30

Definition: Last name, first name, and middle initial of the patient.

Comments: Use a comma and one space to separate last and first names. No space should be left between a prefix and a name (e.g. McCauley, DeClair, or VonFeldt). Titles such as Sir, Msgr., and Dr. should not be recorded. No special characters (e.g. (), *, **, /) should be included in the name. Record hyphenated names with the hyphen (e.g. Smith-Jones, Rebecca). To record a suffix of a name, write the last name, leave a space, and then write the suffix. Follow the suffix with a comma and a first name. For example: Jones II, Robert or Adams Jr., Fred. The middle initial should include only one character. Comments such as 'deceased', test, or "homeless" are not valid names and should not be reported as such.

Edit: Name must have a comma and space separating the last name from the first.

CMS-1500 FL 2

Descriptive Data Element Name: Patient Street Address

XSD Data Type: xs:string

Element Name: pat_address

Accepts Null values: No

Required in XSD: Yes

Minimum Constraint: 5

Maximum Constraint: 70

Definition: The Street address of the patient's residence. P.O. Boxes and Rural Routes should only be used when the physical address is not available.

Comments: The street address should include:

- Street number
- Street direction e.g. N, NW, SW, SE etc. (where applicable)
- Street name
- Street type e.g. Avenue, St, Rd, Road, CT, etc. (where applicable). Refer to the link for commonly used street suffixes.
- http://www.usps.com/ncsc/lookups/abbr_suffix.txt
- Apartment number (where applicable)
- Homeless patient's address should be reported "Homeless".
- Out-of Country patient's address should indicate the Country of Origin

Edit: Street address must be present. Comments such as 'DHS custody', 'return mail', 'deceased', 'Estate of ', names of Nursing homes etc. are not valid addresses and should not be reported in the data as such.

CMS-I 500 FL 5

Descriptive Data Element Name: Patient City

XSD Data Type: xs:string

Element Name: pat_city

Accepts Null values: No

Required in XSD: Yes

Minimum Constraint: 3

Maximum Constraint: 25

Definition: The city of the patient's street address.

Comments: The city of the patient should include the following where applicable

- Abbreviations are not accepted.
- City must be spelled out in full. E.g. Saint Louis, Fort Gibson etc.
- Homeless patient's city should be reported with the City of the ASC.
- Out-of country patient's city should be reported as "Out of Country".

Edit: Valid city must be present.

CMS-I 500 FL 5

Descriptive Data Element Name: Patient State

XSD Data Type: xs:string

Element Name: pat_state

Accepts Null values: No

Required in XSD: Yes

Minimum Constraint: 2

Maximum Constraint: 2

Definition: The state of the patient's address.

Comments: The state of the patient address should include the following where applicable

- Use standard Post Office state abbreviations (e.g. OK for Oklahoma, TX for Texas).
- Homeless patient's state should be reported as "ZZ".
- Out-of Country patient's state should be reported as "XX".

Edit: State abbreviation must be present and valid.
CMS-I500 FL 5

Descriptive Data Element Name: Patient Address Postal Code

XSD Data Type: xs:string

Element Name: pat_zip

Accepts Null values: No

Required in XSD: Yes

Minimum Constraint: 5

Maximum Constraint: 10

Definition: The zip code of the patient's address.

Comments: The zip code of the patient should include the following where applicable

- Nine-digit zip codes are encouraged in the form XXXXX-YYYY or XXXXXYYYY.
- Homeless patient's zip codes should be reported as "99990".
- Out-of Country patient's zip code should be reported as "99999".

Edit: Postal zip code must be present and valid.
Consistent with patient state.

CMS-I500 FL 5

Descriptive Data Element Name: Patient Gender

XSD Data Type: xs:string

Element Name: pat_gender

Accepts Null values: No

Required in XSD: Yes

Minimum Constraint: 1

Maximum Constraint: 1

Definition: Patient gender as recorded at the time of admission or start of care.

Comments: This is a one-character code:

- M = Male**
- F = Female**
- U = Unknown**

Edit: Code must be valid and consistent with diagnosis and procedure codes.
CMS-1500 FL 3

Descriptive Data Element Name: Patient Race

XSD Data Type: xs: positiveInteger

Element Name: pat_race

Accepts Null values: No

Required in XSD: Yes

Minimum Constraint: 1

Maximum Constraint: 1

Definition: This item gives the race of the patient. The information is based on self-identification and is to be obtained from the patient, a relative, or a friend. The facility is **not** to categorize the patient based on observation or personal judgment.

Comments: If the patient chooses not to answer, the facility should enter the code for unknown. If the facility fails to request the information the facility should enter the code for unknown.

1 = American Indian or Alaskan Native

Definition: A person having origins in any of the original peoples of North and South America (including Central America or other Spanish cultural origin), and who maintains tribal affiliation or community attachment.

2 = Asian or Pacific Islander

Definition: A person having origins in any of the original peoples of the Far East, Southeast Asia, or the Indian subcontinent, Hawaii, Guam, Samoa, or other Pacific Islands (including Central America or other Spanish cultural origin), including, for example, Bangladesh, Cambodia, China, India, Japan, Korea, Malaysia, Pakistan, the Philippine Islands, Sri Lanka, Thailand, and Vietnam

3 = Black

Definition: A person having origins in any of the black racial groups of Africa (including Central America or other Spanish cultural origin). It includes people who indicate their race as 'Black, African American, Afro American, Kenyan, Nigerian, or Haitian

4 = White

Definition: A person having origins in any of the original Caucasian peoples of Europe, North Africa or the Middle East (including Central America or other Spanish cultural origin). It includes people who indicate their race as 'White' or report entries such as Irish, German, Italian, Lebanese, Near Easterner, Arab, or Polish

5 = Other

Definition: Any possible options not covered in the above categories.

6 = Unknown

Definition: A person who chooses not to answer the question or the ASC fails to request the information.

Edit: Code must be valid.
Not a CMS-1500 field.

Descriptive Data Element Name: Patient Ethnicity

XSD Data Type: xs: positiveInteger

Element Name: pat_ethnicity

Accepts Null values: No

Required in XSD: Yes

Minimum Constraint: 1

Maximum Constraint: 1

Definition: This item gives the **Patient's answer to the question "Are you Hispanic?"**. The information is based on self-identification and is to be obtained from the patient, a relative or a friend. The facility is **not** to categorize the patient based on observation or personal judgment.

Comments: If the patient chooses not to answer, the facility should enter the code for unknown. If the facility fails to request the information, the facility should enter the code for unknown.

1 = Hispanic origin

Definition: A person of Mexican, Puerto Rican, Cuban, Central or South American, or other Spanish cultural origin, regardless of race.

2 = Not of Hispanic origin

Definition: A person who is not classified in 1.

6 = Unknown

Definition: A person who chooses not to respond to the inquiry.

Edit: Code must be valid.
Not a CMS-1500 field.

Descriptive Data Element Name: Patient Marital Status

XSD Data Type: xs: string

Element Name: pat_marital_stat

Accepts Null values: No

Required in XSD: Yes

Minimum Constraint: 1

Maximum Constraint: 1

Definition: The marital status of the patient at date of admission.

Comments: One-character code, where:

S = Single

M = Married

P = Life Partner

X = Legally separated

D = Divorced

W = Widowed

U = Unknown

Edit: Code must be valid.
CMS-1500 FL 8

Descriptive Data Element Name: Patient Date of Birth

XSD Data Type: xs:date

Element Name: pat_birth_date

Accepts Null values: No

Required in XSD: Yes

Minimum Constraint: 10

Maximum Constraint: 10

Definition: The date of birth of the patient.

Comments: Use the ten-digit format YYYY-MM-DD where:

- MM is the month in two digits ranging from 01 to 12
- DD is the day in two digits ranging from 01 to 31
- YYYY is the year of birth in four digits.

Edit: Date of birth must be:

- Present
- A valid date- not occurring after admit or discharge date
- Consistent with diagnosis
- Age calculated from date of birth and discharge and must be less than 125 years

CMS-I500 FL 3

Descriptive Data Element Name: Patient Social Security Number

XSD Data Type: xs:string

Element Name: pat_ssn

Accepts Null values: No

Required in XSD: Yes

Minimum Constraint: 3

Maximum Constraint: 12

Definition: The last 4 digits of the Social Security Number of the patient receiving care.

Comments: Do not use hyphens. If a patient does not have a Social Security Number, use the following codes:

- 200 for a patient who has no SSN
- 300 for a patient who chooses not to provide his/her SSN.

Edit: Entry must be a valid SSN, or 200 or 300.

CMS-I500 FL This field may be present in position 1a.

Descriptive Data Element Name: Patient Control Number

XSD Data Type: xs: string

Element Name: pat_control_no

Accepts Null values: No

Required in XSD: Yes

Minimum Constraint: 2

Maximum Constraint: 17

Definition: A code assigned by the facility uniquely identifying individual discharge events.

Comments: This code will be used for reference in correspondence, problem solving, edit corrections and return of grouped data.

The PCN identifies a single surgical encounter for a patient and maybe called or defined as an account number.

The PCN is different from the medical record number, which identifies an individual patient and remains the same through multiple facility visits.

Edit: PCN code must be present and should be unique within a facility.
CMS-I 500 FL 26

Descriptive Data Element Name: Patient Medical Record Number

XSD Data Type: xs: string

Element Name: pat_medical_rec_no

Accepts Null values: No

Required in XSD: Yes

Minimum Constraint: 2

Maximum Constraint: 17

Definition: A unique identifier assigned by the facility to the patient's medical/health record at the first admission and used for all subsequent admissions.

Edit: MRN code must be present and should represent a unique patient
Not a CMS-I500 field.

Descriptive Data Element Name: National Provider Number

XSD Data Type: xs: string

Element Name: national_provider_no

Accepts Null values: No

Required in XSD: Yes

Minimum Constraint: 10

Maximum Constraint: 10

Definition: The ten-digit number assigned to the facility as a result of HIPAA's National Provider Identifier (NPI) regulations.

Edit: Number must be valid and match the CMS national provider list.
CMS-I 500 FL 32a

Descriptive Data Element Name: Admission Date

XSD Data Type: xs:date

Element Name: admit_date

Accepts Null values: No

Required in XSD: Yes

Minimum Constraint: 10

Maximum Constraint: 10

Definition: The date the patient was admitted for ambulatory surgery.

Comments: Admission date has a 10 digit format YYYY-MM-DD where:

- MM is the month in two digits ranging from 01 to 12
- DD is the day in two digits ranging from 01 to 31
- YYYY is the year in four digits (e.g. 2011)

Edit: Admission date must be:

- Present and valid.
- No earlier than the date of birth.
- No later than discharge date.

CMS-1500 FL 24a(1)

Descriptive Data Element Name: Admit Hour

XSD Data Type: xs:positiveInteger

Element Name: admit_hour

Accepts Null values: No

Required in XSD: Yes

Minimum Constraint: 2

Maximum Constraint: 2

Definition: The hour during which the patient was admitted for ambulatory surgery.

Comments: Admit hour is a 2-digit format with the following structure:

Code	Time – AM	Code	Time - PM
00	12:00 – 12:59 Midnight	12	12:00–12:59 Noon
01	01:00 – 01:59	13	01:00 – 01:59
02	02:00 – 02:59	14	02:00 – 02:59
03	03:00 – 03:59	15	03:00 – 03:59
04	04:00 – 04:59	16	04:00 – 04:59
05	05:00 – 05:59	17	05:00 – 05:59
06	06:00 – 06:59	18	06:00 – 06:59
07	07:00 – 07:59	19	07:00 – 07:59
08	08:00 – 08:59	20	08:00 – 08:59
09	09:00 – 09:59	21	09:00 – 09:59
10	10:00 – 10:59	22	10:00 – 10:59
11	11:00 – 11:59	23	11:00 – 11:59
99	Hour Unknown		

Edits: Valid hour must be present.

Not a CMS-1500 field.

Descriptive Data Element Name: Discharge Date

XSD Data Type: xs:date

Element Name: disch_date

Accepts Null values: No

Required in XSD: Yes

Minimum Constraint: 10

Maximum Constraint: 10

Definition: The date the patient was discharged after ambulatory surgery.

Comments: Discharge date is in a ten digit format YYYY-MM-DD where:

- MM is the month in two digits ranging from 01 to 12
- DD is the day in two digits ranging from 01 to 31
- YYYY is the year of discharge (e.g. 2011)

Edit: Discharge date must be:

- Present and valid
- No earlier than admission date
- No earlier than date of birth

CMS-1500 FL 24a(1)

Descriptive Data Element Name: Discharge Hour

XSD Data Type: xs:positiveInteger

Element Name: disch_hour

Accepts Null values: No

Required in XSD: Yes

Minimum Constraint: 2

Maximum Constraint: 2

Definition: The hour during which the patient was discharged from surgery center.

Comments: Discharge hour is a 2-digit format with the following structure:

Code	Time – AM	Code	Time - PM
00	12:00 – 12:59 Midnight	12	12:00–12:59 Noon
01	01:00 – 01:59	13	01:00 – 01:59
02	02:00 – 02:59	14	02:00 – 02:59
03	03:00 – 03:59	15	03:00 – 03:59
04	04:00 – 04:59	16	04:00 – 04:59
05	05:00 – 05:59	17	05:00 – 05:59
06	06:00 – 06:59	18	06:00 – 06:59
07	07:00 – 07:59	19	07:00 – 07:59
08	08:00 – 08:59	20	08:00 – 08:59
09	09:00 – 09:59	21	09:00 – 09:59
10	10:00 – 10:59	22	10:00 – 10:59
11	11:00 – 11:59	23	11:00 – 11:59
99	Hour Unknown		

Edits: Valid hour must be present.
Not a CMS-1500 field.

Descriptive Data Element Name: Patient Discharge Status

XSD Data Type: xs: string

Element Name: pat_disch_status

Accepts Null values: No

Required in XSD: Yes

Minimum Constraint: 2

Maximum Constraint: 2

Definition: A code indicating patient status at the time of discharge.

Comments: Codes for this two-digit field are:

- 01= Discharged to home or self-care (routine discharge)
- 02= Discharge/transferred to another short-term general hospital for inpatient care
- 03= Discharged/transferred to skilled nursing facility (SNF) with Medicare Certification in Anticipation of Skilled Care
- 04= Discharged/transferred to an intermediate care facility (ICF)
- 06= Discharged/transferred to home under care of organized home health service organization
- 07= Left against medical advice or discontinued care
- 20= Expired
- 21= Discharge/transferred to court/law enforcement
- 43= Discharged/transferred to a federal health care facility.
- 62= Discharged/transferred to an inpatient rehabilitation facility (IRF) including distinct part units of a hospital.
- 63= Discharged/transferred to a long term care hospital (LTCH).
- 64= Discharged/transferred to a nursing facility certified under Medicaid but not certified under Medicare.
- 66= Discharged/transferred to a Critical Access Hospital (CAH)
- 70= Discharged/transferred to another Type of Health Care Institution not defined elsewhere in this Code List

Edit: Discharge status code must be present and valid.
Not a CMS-1500 field.

Descriptive Data Element Name: Referring Physician Identifier

XSD Data Type: xs: string

Element Name: referring_phy_id

Accepts Null values: No

Required in XSD: Yes

Minimum Constraint: 4

Maximum Constraint: 10

Definition: The ten-digit National Provider Identifier Number (NPI) of the physician who certified and re-certified the medical necessity of the surgical procedures rendered or who has primary responsibility for the patient's medical care and treatment.

Comments: Use **OTH000** if the NPI of the physician is not yet available or being processed by CMS.

Edit: Entry must be a valid NPI number.

CMS 1500 FL 17B.

Descriptive Data Element Name: Primary Payer Identifier - not required at this time

XSD Data Type: xs: string

Element Name: prim_payer_id

Accepts Null values: No

Required in XSD: Yes

Minimum Constraint: 15

Maximum Constraint: 15

Definition: National Health Plan Identifier, when available, identifying the primary payer for this bill.

Comments: This field is to contain the National Health Plan Identifier of the primary payer organization.

Edit: The identifier must be that of a licensed health insurer or self-pay.
Not a CMS-1500 field.

Descriptive Data Element Name: Primary Payer Name

XSD Data Type: xs: string

Element Name: prim_payer_name

Accepts Null values: No

Required in XSD: Yes

Minimum Constraint: 2

Maximum Constraint: 25

Definition: Payer name identifying the primary payer for this bill.

Comments: This field is to contain the name of the primary payer, spelled out as completely as space allows. If a name has more than 25 characters, use abbreviations that can be used to uniquely identify the payer. If the patient paid for or was responsible for the surgical encounter, primary payer should indicate self-pay.

Edit: The name must be present and that of a health insurer or self-pay.
CMS-1500 FL 11c.

Descriptive Data Element Name: Secondary Payer Identifier - not required at this time

XSD Data Type: xs: string

Element Name: second_payer_id

Accepts Null values: Yes

Required in XSD: No

Minimum Constraint: 15

Maximum Constraint: 15

Definition: National Health Plan Identifier, when available, identifying the secondary payer for this bill.

Comments: This field is to contain the National Health Plan Identifier of the secondary payer organization.

Edit: The identifier must be that of a licensed health insurer or self-pay.

Not a CMS-1500 field.

Descriptive Data Element Name: Secondary Payer Name

XSD Data Type: xs: string

Element Name: second_payer_name

Accepts Null values: Yes

Required in XSD: No

Minimum Constraint: 2

Maximum Constraint: 25

Definition: Payer name identifying the secondary payer for this bill.

Comments: This field is to contain the name of the secondary payer, spelled out as completely as space allows. If a name has more than 25 characters, use abbreviations that can be used to uniquely identify the payer. If the patient paid for or was responsible for part of the surgical encounter, secondary payer should indicate self-pay.

Edit: The name must be that of a licensed health insurer or self-pay
CMS-1500 FL 9d

Descriptive Data Element Name: Primary Payer Classification

XSD Data Type: xs: positiveInteger

Element Name: prim_payer_class

Accepts Null values: No

Required in XSD: Yes

Minimum Constraint: 1

Maximum Constraint: 1

Definition: This field indicates the payer group.

Comments: The payer group should be classified as:

1. **Commercial** - Includes HMO, PPO, POS, Indemnity, BCBS, Aetna, HealthChoice etc.
2. **Medicare** - Including HMO and insurance managed Medicare
3. **Medicaid** - Including Medicaid pending
4. **Veterans affairs / Military** - Includes Champus, ChampVA and Tricare.
5. **Workers Compensation**
6. **Uninsured/ Self –pay**
7. **Others** - Payers not in any of the above groups and including charity, Indian Health, auto-liability, DOC inmate.

Edit: The code must be present and valid.
Not a CMS-1500 field.

Descriptive Data Element Name: Total Charges

XSD Data Type: xs: string

Element Name: total_charges

Accepts Null values: No

Required in XSD: Yes

Minimum Constraint: 3

Maximum Constraint: 6

Definition: The total charges associated with the ambulatory surgery encounter.

Comments: This entry is:

- Rounded to nearest whole dollar
- A maximum of five digits

Edit: This field must be present and valid.

CMS-I500 FL 28

Data Elements **diag**

Total Attributes: 1

Total Elements: 1

Attribute Name: princ_diag

Data Element Name: oth_diag_code

Descriptive Data Element Name: Principal Diagnosis

XSD Data Type: xs:string

Attribute Name: princ_diag

Accepts Null values: No

Required in XSD: Yes

Minimum Constraint: 3

Maximum Constraint: 5

Definition: The ICD-9-CM code describing the condition or problem that is the reason for the encounter as shown in the provider records to be chiefly responsible for the ambulatory surgery performed during this visit.

Comments: To code the principal diagnosis:

- Use an ICD-9-CM code without a decimal point.
- Enter all three, four, and five digits or to the highest level of specificity.
- Enter the "V" prefix as appropriate

Edit: A principal diagnosis must be:

- Present and valid
- Consistent with sex and age
- An E-code should not be entered as the principal diagnosis.

CMS-I500 FL 21(1)

Descriptive Data Element Name: Other Diagnosis Codes (1 to 15)

XSD Data Type: xs:string

Element Name: oth_diag_code

Accepts Null values: Yes

Required in XSD: No

Minimum Constraint: 3

Maximum Constraint: 5

Definition: ICD-9-CM codes describing other diagnoses corresponding to additional conditions that co-exist at the time of the encounter.

Comments: Up to 15 secondary diagnoses may be recorded.

- Use an ICD-9-CM code
- Enter all three, four, and five digits

Edit: A secondary diagnosis must be:

- Valid
- Consistent with sex and age

CMS-I500 FL 21(2,3,4)

Data Elements procs

Total Attributes: 3

Total Elements: 1

Attribute Name: princ_cpt_proc, princ_cpt_proc_phys_id, princ_cpt_proc_date

Data Element Name: proc

Descriptive Data Element Name: Principal Procedure CPT Code and Modifiers

XSD Data Type: xs: string

Attribute Name: princ_cpt_proc

Accepts Null values: No

Required in XSD: Yes

Minimum Constraint: 5

Maximum Constraint: 13

Definition: The Principal Current Procedural Terminology (CPT) procedure code identifies the principal ambulatory procedure performed during the surgery encounter. The principal procedure is that procedure most related to the principal diagnosis.

A modifier provides the means by which the reporting physician can indicate that a service or procedure that has been performed has been altered by some specific circumstance but not changed in its definition or code.

Comments: Code entry should be in the first five positions in the field and include all digits. The remaining eight positions are for all qualifying modifiers.

Edit: Principal Procedure CPT code field must be:

- Present unless one of the secondary diagnosis codes is V64.
- Valid
- Consistent with patient's sex and age
- HCPCS codes are not valid as a principal procedure except for D9999, G0104, G0105, G0121, G0260, G0289, G0290, C1716, C1718, C1719, C1720, 0020T or as required by Medicare or Medicaid. Code 3415 is an error if no other valid surgical CPT is present.

CPT Modifiers must be:

- Valid, if present
- Two digits in length

CMS-I500 FL 24d(1).

Descriptive Data Element Name: Principal Procedure - Physician Identifier

XSD Data Type: xs:string

Attribute Name: princ_cpt_proc_phys_id

Accepts Null values: No

Required in XSD: Yes

Minimum Constraint: 5

Maximum Constraint: 10

Definition: The 10 digit National Provider Identifier (NPI) of the physician performing the principal procedure.

Comments: Use **OTH000** if the NPI of the physician is not yet available or being processed by CMS.

Edit: Field must contain a valid NPI.

CMS-I500 FL24j

Descriptive Data Element Name: Principal Procedure Date

XSD Data Type: xs:date

Attribute Name: princ_cpt_proc_date

Accepts Null values: No

Required in XSD: Yes

Minimum Constraint: 10

Maximum Constraint: 10

Definition: The date the principal procedure was performed.

Comments: Principal procedure date is in a ten digit format YYYY-MM-DD where:

- MM is the month in two digits ranging from 01 to 12
- DD is the day in two digits ranging from 01 to 31
- YYYY is the year of discharge (e.g. 2011)

Edit: Principal procedure date must be:

- Present and valid
- No earlier than date of encounter
- No later than discharge date
- No earlier than date of birth

CMS-I500 FL 24a(1).

Data Elements procs/proc

Total Elements: 2

Data Element Name: oth_cpt_proc_code, oth_cpt_proc_phys_id

Descriptive Data Element Name: **Other Procedure CPT Codes and Modifiers (1-5)**

XSD Data Type: xs: string

Element Name: oth_cpt_proc_code

Accepts Null values: Yes

Required in XSD: No

Minimum Constraint: 5

Maximum Constraint: 13

Definition: The Current Procedural Terminology (CPT) procedure code(s) identifies all significant secondary procedure(s) performed during the surgery encounter and any applicable modifiers.

A modifier provides the means by which the reporting physician can indicate that a service or procedure that has been performed has been altered by some specific circumstance but not changed in its definition or code.

Comments: Up to 5 secondary procedure CPT codes and modifiers may be recorded. See comments for the principal procedure CPT code. Code entry should be in the first five positions in the field and include all digits. The remaining eight positions are for all qualifying modifiers. Code 3415 is an error if no other valid surgical CPT is present.

Edit: Other Procedure CPT Codes 1 – 5 must be:

- Present only if a principal procedure CPT code is present
- Valid
- Consistent with patient's sex and age

CPT Modifiers must be:

- Valid, if present
- Two digits in length

CMS-1500 FL 24d(2,3,4,5,6).

Descriptive Data Element Name: **Other Procedure – Physician Identifiers (1-5)**

XSD Data Type: xs: string

Element Name: oth_cpt_proc_phys_id

Accepts Null values: Yes

Required in XSD: No

Minimum Constraint: 5

Maximum Constraint: 10

Definition: The 10 digit National Provider Identifier (NPI) of the physician performing other or secondary procedures.

Comments: Use **OTH000** if the NPI of the physician is not yet available or being processed by CMS.

Edit: Field if present must contain a valid NPI.

CMS-1500 FL 24j(2,3,4,5,6).

Data Elements

apcs/apc

Total Elements: 1

Element Name: apcs

Descriptive Data Element Name: Facility Assigned Ambulatory Patient Classification APC (I-3)
Not required at this time

XSD Data Type: xs: string

Element Name: apc

Accepts Null values: No

Required in XSD: Yes

Minimum Constraint: 3

Maximum Constraint: 5

Definition: The Ambulatory Patient Classification(s) assigned to the ambulatory record by the facility.

Comments: The APC field has to be between three to five digits in length or can be preceded with zeroes.

Edit: The APC field must be:
* Valid
* Consistent with age and sex
Not a CMS-1500 field.

Data Elements

hci_data/Trailer

Total Elements: 1

Element Name: total_records

Descriptive Data Element Name: Total number of records in file

XSD Data Type: xs:positiveInteger

Element Name: total_records

Accepts Null values: No

Required in XSD: Yes

Minimum Constraint: 2

Maximum Constraint: 5

Definition: Total number of records in the file submitted.

Edit: Must reflect the actual total number of records.

Not a CMS-1500 field.

**Health Care Information Staff and Contact Information
(405) 271-6225**

Heather Hunn RHIAHealth Information Analystheathernh@health.ok.gov
Lou Ann Sanders, RHIT, LPNHealth Information Analyst louanns@health.ok.gov
Binitha Kunnel, MSProject Coordinatorbinithak@health.ok.gov
Jeffrey Carlisle IT jeffreyc@health.ok.gov
Kelly Baker, MPH Director Kellyb@health.ok.gov