

Chapter 9

CULVERTS

ODOT ROADWAY DRAINAGE MANUAL

November 2014

Chapter 9
CULVERTS

Table of Contents

<u>Section</u>	<u>Page</u>
9.1 INTRODUCTION.....	9.1-1
9.1.1 Overview.....	9.1-1
9.1.2 Culvert Definition	9.1-1
9.1.3 Concepts	9.1-2
9.1.4 Symbols.....	9.1-3
9.2 GENERAL CONSIDERATIONS.....	9.2-1
9.3 DESIGN CRITERIA.....	9.3-1
9.3.1 General Criteria	9.3-1
9.3.2 Site Criteria.....	9.3-1
9.3.2.1 Structure Type Selection.....	9.3-1
9.3.2.2 Slope, Length and Skewness	9.3-1
9.3.2.3 Ice Buildup	9.3-1
9.3.2.4 Debris Control	9.3-2
9.3.3 Design Limitations	9.3-2
9.3.3.1 Design Flood Frequency	9.3-2
9.3.3.2 Review Flood Frequency	9.3-2
9.3.3.3 Allowable Headwater	9.3-3
9.3.3.4 Allowable Headwater for Temporary On-Site Traffic Detour	9.3-3
9.3.3.5 Tailwater Relationship (Channel).....	9.3-4
9.3.3.6 Tailwater Relationship (Confluence or Large-Water Body).....	9.3-4
9.3.3.7 Maximum Outlet Velocity	9.3-5
9.3.3.8 Minimum Culvert Velocity	9.3-5
9.3.3.9 Storage (Temporary or Permanent).....	9.3-5
9.3.3.10 Minimum Structure Cover	9.3-6
9.4 DESIGN FEATURES	9.4-1
9.4.1 Culvert Shape and Material Selection	9.4-1
9.4.2 Culvert Size	9.4-1
9.4.3 Broken-Back Culverts.....	9.4-2
9.4.4 Land-Use Culvert.....	9.4-2
9.4.5 Multiple Barrels.....	9.4-2
9.4.6 Culvert Slopes	9.4-3
9.4.7 Pipe Length Measurement for Culverts	9.4-3
9.4.8 Skewed Installations.....	9.4-3
9.4.9 End Treatment (Inlet or Outlet).....	9.4-4

Table of Contents

(Continued)

<u>Section</u>		<u>Page</u>
9.4.10	Safety Considerations	9.4-4
9.4.11	Median and Entrance Placement	9.4-5
9.4.12	Weep Holes	9.4-5
9.4.13	Performance Curves.....	9.4-5
9.4.14	Sag Culverts	9.4-5
9.5	RELATED DESIGNS	9.5-1
9.5.1	Erosion and Sediment Control.....	9.5-1
9.5.2	Environmental Considerations and Fishery Protection.....	9.5-1
9.5.3	Irrigation Facilities.....	9.5-1
9.5.4	Outlet Protection.....	9.5-2
9.5.5	Relief Opening.....	9.5-2
9.6	HYDRAULIC DESIGN.....	9.6-1
9.6.1	General.....	9.6-1
9.6.2	ODOT Standard Practice.....	9.6-1
	9.6.2.1 Design Discharge.....	9.6-2
	9.6.2.2 Hydraulics Control Section.....	9.6-2
	9.6.2.3 Minimum Performance.....	9.6-2
9.6.3	Inlet Control	9.6-2
	9.6.3.1 Factors Influencing Inlet Control	9.6-3
	9.6.3.2 Hydraulics	9.6-4
	9.6.3.3 Inlet Depression	9.6-5
9.6.4	Outlet Control	9.6-5
	9.6.4.1 Factors Influencing Outlet Control	9.6-5
	9.6.4.2 Hydraulics (Full Barrel Flow).....	9.6-7
	9.6.4.3 Energy Grade Line.....	9.6-9
	9.6.4.4 HDS-5 Nomographs (Full Flow).....	9.6-10
	9.6.4.5 HDS-5 Nomographs (Partial Full Flow) — Approximate Method	9.6-10
9.6.5	Outlet Velocity	9.6-11
	9.6.5.1 Inlet Control.....	9.6-11
	9.6.5.2 Outlet Control.....	9.6-11
9.6.6	Roadway Overtopping	9.6-11
	9.6.6.1 Roadway Crest Length	9.6-12
	9.6.6.2 Total Flow	9.6-12

Table of Contents
(Continued)

<u>Section</u>	<u>Page</u>
9.6.7 Performance Curves.....	9.6-12
9.6.8 Culvert Design Form.....	9.6-14
9.7 DESIGN PROCEDURE	9.7-1
9.8 DESIGN EXAMPLE USING NOMOGRAPHS.....	9.8-1
9.8.1 HY-8 Solution	9.8-6
9.9 DOCUMENTATION	9.9-1
9.9.1 Draft Hydraulic Design Report.....	9.9-1
9.9.2 Final Hydraulic Design Report.....	9.9-2
9.10 STORAGE ROUTING	9.10-1
9.10.1 Introduction.....	9.10-1
9.10.2 Design Procedure.....	9.10-1
9.11 TAPERED INLETS.....	9.11-1
9.11.1 General.....	9.11-1
9.11.2 Side-Tapered Inlets	9.11-1
9.11.3 Slope-Tapered Inlets	9.11-3
9.11.4 Hydraulic Design	9.11-4
9.11.4.1 Inlet Control.....	9.11-4
9.11.4.2 Side-Tapered Inlet	9.11-5
9.11.4.3 Slope-Tapered Inlet	9.11-5
9.11.4.4 Outlet Control.....	9.11-5
9.11.5 Design Methods.....	9.11-5
9.11.6 Performance Curves.....	9.11-6
9.12 BROKEN-BACK CULVERTS	9.12-1
9.12.1 Introduction.....	9.12-1
9.12.2 Guidelines.....	9.12-1
9.12.3 Design Procedure.....	9.12-1
9.13 AQUATIC ORGANISM PASSAGE	9.13-1
9.14 DESIGN AIDS.....	9.14-1
9.15 REFERENCES.....	9.15-1

List of Figures

<u>Figure</u>	<u>Page</u>
Figure 9.1-A — SYMBOLS, DEFINITIONS AND UNITS	9.1-4
Figure 9.3-A — RECOMMENDED MINIMUM DESIGN FLOOD FREQUENCY	9.3-3
Figure 9.3-B — EXAMPLE OF JOINT PROBABILITY ANALYSIS FOR STREAMS NEAR VIRGINIA BEACH, VA (early 1970s).....	9.3-4
Figure 9.6-A — TYPES OF INLET CONTROL	9.6-3
Figure 9.6-B — INLET CONTROL CURVES	9.6-4
Figure 9.6-C — TYPES OF OUTLET CONTROL	9.6-6
Figure 9.6-D — FULL FLOW ENERGY AND HYDRAULIC GRADE LINES.....	9.6-10
Figure 9.6-E — OVERALL PERFORMANCE CURVE	9.6-13
Figure 9.6-F — CULVERT DESIGN FORM	9.6-14
Figure 9.8-A — CULVERT DESIGN FORM AND PERFORMANCE CURVE FOR DESIGN EXAMPLE	9.8-5
Figure 9.11-A — SIDE-TAPERED INLET	9.11-2
Figure 9.11-B — SIDE-TAPERED INLET WITH UPSTREAM DEPRESSION CONTAINED BETWEEN WINGWALLS.....	9.11-2
Figure 9.11-C — SLOPE-TAPERED INLET WITH VERTICAL FACE.....	9.11-3
Figure 9.11-D — INLET CONTROL PERFORMANCE CURVES (Schematic).....	9.11-4
Figure 9.11-E — CULVERT PERFORMANCE CURVE (Schematic)	9.11-6
Figure 9.12-A — THREE-UNIT BROKEN-BACK CULVERT	9.12-1
Figure 9.12-B — TWO-UNIT BROKEN-BACK CULVERT.....	9.12-2
Figure 9.13-A — EMBEDDED CULVERT WITH BAFFLES	9.13-1
Figure 9.14-A — MANNING'S n VALUES FOR CULVERTS	9.14-2
Figure 9.14-B — ENTRANCE LOSS COEFFICIENTS (Outlet Control, Full or Partly Full)	9.14-3
Figure 9.14-C — HEADWATER DEPTH FOR CONCRETE PIPE CULVERTS WITH INLET CONTROL.....	9.14-4
Figure 9.14-D — HEADWATER DEPTH FOR C. M. PIPE CULVERTS WITH INLET CONTROL	9.14-5
Figure 9.14-E — HEADWATER DEPTH FOR CIRCULAR PIPE CULVERTS WITH BEVELED RING INLET CONTROL	9.14-6
Figure 9.14-F — CRITICAL DEPTH (Circular Pipe).....	9.14-7
Figure 9.14-G — HEAD FOR CONCRETE PIPE CULVERTS FLOWING FULL (n = 0.012).....	9.14-8
Figure 9.14-H — HEAD FOR STANDARD C. M. PIPE CULVERTS FLOWING FULL (n = 0.024).....	9.14-9
Figure 9.14-I — HEAD FOR STRUCTURAL PLATE CORRUGATED METAL PIPE CULVERTS FLOWING FULL (n = 0.0328 to 0.0302)	9.14-10
Figure 9.14-J — HEADWATER DEPTH FOR BOX CULVERTS WITH INLET CONTROL	9.14-11

List of Figures

(Continued)

<u>Figure</u>	<u>Page</u>
Figure 9.14-K — HEADWATER DEPTH FOR INLET CONTROL, RECTANGULAR BOX CULVERTS, FLARED WINGWALLS 18° TO 33.7° and 45° WITH BEVELED EDGE AT TOP OF INLET	9.14-12
Figure 9.14-L — HEADWATER DEPTH FOR INLET CONTROL, RECTANGULAR BOX CULVERTS, 90° HEADWALL, CHAMFERED OR BEVELED INLET EDGES.....	9.14-13
Figure 9.14-M — HEADWATER DEPTH FOR INLET CONTROL, SINGLE BARREL BOX CULVERTS, SKEWED HEADWALLS, CHAMFERED OR BEVELED INLET EDGES	9.14-14
Figure 9.14-N — HEADWATER DEPTH FOR INLET CONTROL, RECTANGULAR BOX CULVERTS, FLARED WINGWALLS, NORMAL AND SKEWED INLET EDGES, 3/4" CHAMFER AT TOP OF OPENING	9.14-15
Figure 9.14-O — HEADWATER DEPTH FOR INLET CONTROL, RECTANGULAR BOX CULVERTS, OFFSET FLARED WINGWALLS AND BEVELED EDGE AT TOP OF INLET	9.14-16
Figure 9.14-P — CRITICAL DEPTH (Rectangular Section)	9.14-17
Figure 9.14-Q — HEAD FOR CONCRETE BOX CULVERTS FLOWING FULL (n = 0.012)	9.14-18
Figure 9.14-R — DISCHARGE COEFFICIENTS FOR ROADWAY OVERTOPPING	9.14-19
Figure 9.14-S — CULVERT DESIGN FORM	9.14-20
Figure 9.14-T — SIDE/SLOPE TAPERED DESIGN FORM.....	9.14-21

Chapter 9

CULVERTS

9.1 INTRODUCTION

The highway culvert is located and designed to adequately handle drainage across or from the highway right-of-way. Culverts are usually considered minor structures, but they are of importance to adequate drainage and proper functioning of the highway facilities. Although the cost of the individual culvert may be small, the total cost of the culvert construction constitutes a substantial share of the total cost of the entire project.

9.1.1 Overview

This chapter provides the following:

- design criteria, Section 9.3;
- design features, Section 9.4;
- related designs, Section 9.5;
- hydraulic design practices and methods, Section 9.6;
- design procedure, Section 9.7;
- design example, Section 9.8;
- documentation, Section 9.9;
- storage routing overview, Section 9.10;
- tapered inlet overview, Section 9.11;
- broken-back culvert overview, Section 9.12;
- aquatic organism passage overview, Section 9.13; and
- design aids for circular and box shapes, Section 9.14.

This chapter is based on Chapter 11 “Culverts” of AASHTO *Drainage Manual* (1) and FHWA Hydraulic Design Series No. 5 (HDS-5), *Hydraulic Design of Highway Culverts* (2).

9.1.2 Culvert Definition

A culvert is defined as the following:

- A structure that can be designed hydraulically to take advantage of submergence to increase hydraulic capacity.
- A structure used to convey surface runoff through embankments.
- A structure, as distinguished from bridges, that is usually covered with embankment and is composed of structural material around the entire perimeter, although some are supported on spread footings with the streambed serving as the bottom of the culvert.

- A structure (bridge) designed hydraulically as a culvert is addressed in this chapter, regardless of its span length.

9.1.3 Concepts

The following concepts are important in culvert design:

1. Critical Depth. In channels with regular cross section, critical depth is the depth at which the specific energy of a given flow rate is at a minimum. For a given discharge and cross-section geometry, there is only one critical depth.
2. Crown. The crown is the inside top of the culvert.
3. Flow Type. USGS (3) established six culvert flow types, which assist in determining the flow conditions at a particular culvert site. Chapter 3 of FHWA HDS-5 (2) uses 7 culvert flow types. Diagrams of these flow types are provided in Section 9.6.
4. Free Outlet. Free outlet occurs when tailwater depth is equal to or lower than critical depth. For culverts having free outlets, lowering of the tailwater has no effect on the discharge or the backwater profile upstream of the tailwater.
5. Improved Inlet. An improved inlet has an entrance geometry that decreases the flow contraction at the inlet and thus increases the capacity of culverts. These inlets are referred to as either side- or slope-tapered. The side-tapered inlet has a face wider than the culvert. The slope-tapered inlet has both a larger face and increased flow-line slope at the entrance. Beveled edges at the culvert face may also improve the hydraulic capacity of a culvert for both conventional and improved inlets.
6. Invert. The invert is the flowline of the culvert (inside bottom).
7. Normal Depth. Normal depth occurs in a channel or culvert when the slope of the water surface and channel bottom is the same and the water depth remains constant. The discharge and velocity are constant throughout the reach. Normal flow will exist in a culvert operating on a constant slope provided that the culvert is sufficiently long.
8. Slope. The measurement of inclination of a pipe, representing the difference in elevation of the inlet and outlet inverts along the centerline of the pipe. A steep slope occurs where the normal depth is less than the critical depth. A mild slope occurs where the normal depth is greater than the critical depth.
9. Submerged. A submerged outlet occurs where the tailwater elevation is higher than the crown of the culvert. A submerged inlet occurs where the headwater is greater than $1.2D$, where D is the culvert diameter or barrel height.

9.1.4 Symbols

To provide consistency within this chapter, the symbols given in Figure 9.1-A will be used. These symbols were selected because they are consistent with HDS-5 (2).

Symbol	Definition	Units
A	Area of cross section of flow	ft ²
B	Barrel width	in or ft
B _f	Width of face section of a tapered inlet	ft
C _d	Coefficient of discharge for flow over an embankment	—
D	Culvert diameter or barrel height	in or ft
d	Depth of flow	ft
d _c	Critical depth of flow	ft
d _n	Normal depth	ft
g	Acceleration due to gravity	ft/s ²
H	Headloss, sum of H _e + H _f + H _o	ft
H _b	Bend headloss	ft
H _e	Entrance headloss	ft
H _f	Friction headloss	ft
H _j	Headloss at junction	ft
H _g	Headloss at grate	ft
HL	Total energy losses	ft
H _o	Outlet or exit headloss	ft
H _v	Velocity head	ft
h _o	Hydraulic grade line height above outlet invert	ft
HW	Headwater depth (subscript indicates section, f=face, t=throat)	ft
HW _a	Headwater allowable	ft
HW _i	Headwater depth above inlet invert	ft
HW _o	Headwater depth above the outlet invert	ft
HW _r	Upstream depth, measured above the roadway crest	ft
k _e	Entrance loss coefficient	—
L	Length of culvert	ft
n	Manning's roughness coefficient	—
P	Wetted perimeter	ft
Q	Rate of discharge	cfs
Q _d	Design discharge	cfs
Q _o	Overtopping flow	cfs
Q _r	Routed (reduced) peak flow	cfs
R	Hydraulic radius (A/P)	ft
S	Slope of culvert	ft/ft
S _o	Slope of streambed	ft/ft
TW	Tailwater depth above outlet invert of culvert	ft
V	Mean velocity of flow with barrel full	fps
V _d	Mean velocity in downstream channel	fps
V _o	Mean velocity of flow at culvert outlet	fps
V _u	Mean velocity in upstream channel	fps
γ	Unit weight of water	lb/cf
τ	Tractive force	lb/ft ²

Figure 9.1-A — SYMBOLS, DEFINITIONS AND UNITS

9.2 GENERAL CONSIDERATIONS

The following general considerations are specific to the design of culverts:

- A completed design of the culvert should include structural, environmental and hydraulic aspects. Only the hydraulic aspect of the design of the culvert and the choice of culvert materials will be discussed in this chapter.
- The selected design flood frequency should be consistent with the roadway classification.
- Site information should include topographic features, channel characteristics, aquatic habitat, high-water information, existing structures and other related site-specific information (e.g., soil information, water quality).
- The culvert location should be investigated to minimize the potential for sediment buildup in culvert barrels so that maintenance can be reduced.
- When the culvert barrels must be partially filled with streambed materials for fish or aquatic organism passage purpose, the hydraulics designer should use the culvert design procedures that are either accepted by the local regulatory agency(ies) or as described in FHWA Hydraulic Engineering Circular No. 26 (HEC-26) (4).
- Culverts should be designed to accommodate debris or proper provisions should be made for debris maintenance.
- Flood frequencies greater than the design flood frequency should be considered if there are potential adverse impacts to properties on both sides of the highway or to the structural stability/integrity of the highway embankments.
- The choice of the culvert materials should consider the desired service life of the culvert and the site conditions affecting this service life. These include abrasion, corrosion, structural (height of fill) factors and replacement cost commensurate with the risk at the site.
- Culverts should be located and designed to present a minimum hazard to traffic and people. The design should also include the environmental, aesthetic, political or nuisance considerations and land-use requirements.
- The detail of documentation for each culvert site should be commensurate with the risk and importance of the structure. Design data and calculations should be assembled in an orderly fashion and retained for future reference.
- Where practicable, some means should be provided for personnel and equipment access to facilitate maintenance.
- Culverts should be inspected and maintained regularly to ensure they operate as designed.

9.3 DESIGN CRITERIA

9.3.1 General Criteria

The following attributes should be prevalent when considering a culvert:

1. The culvert should handle all water, bedload and floating debris at all stages of the rising water up to including the design storm.
2. The culvert placement should not cause damage to surrounding property.
3. The culvert should provide a transfer of material (water and what it contains), without a change in the flow pattern above and below the structure.
4. The design of any culvert should take into consideration the soil type, the outfall velocity and the depth of the flow. When the velocities indicate probable erosion, steps should be taken to change the culvert design, reducing the velocity or protect the outfall location with energy dissipators.
5. The culvert design should take into consideration the low flow and velocity conditions of flow to guard against possible sedimentation within the culvert. The design structure adequate for peak flow conditions does not guarantee that it is also adequate for low flow conditions. A check on the flow conditions can tell whether the structure will maintain the minimum flow rate necessary to keep the structure clean.

9.3.2 Site Criteria

9.3.2.1 Structure Type Selection

Culverts may be used where:

- bridges are not hydraulically required,
- debris and ice are tolerable, and
- bridges are uneconomical.

9.3.2.2 Slope, Length and Skewness

The culvert slope, length and skewness should be chosen to approximate existing topography to the degree practicable. The skew angle of the culvert is measured from a line perpendicular to the roadway centerline. The culvert invert should be aligned with the channel bottom and with the skew angle of the stream. Design details are provided for culvert slope (see Sections 9.4.6), length (see Section 9.4.7) and skewness (see Section 9.4.8).

9.3.2.3 Ice Buildup

Ice buildup should be mitigated as necessary by:

- assessing the flood damage potential resulting from a plugged culvert,
- increasing the culvert size, and
- incorporating the ice buildup prevention or thawing features within the culvert.

9.3.2.4 Debris Control

Debris control devices may be designed using the procedures as shown in the FHWA Hydraulic Engineering Circular No. 9 (HEC-9) (5) and should be considered:

- where experience or physical evidence indicates the watercourse will transport a heavy volume of controllable debris,
- where fish migration needs to be addressed,
- for culverts located in mountainous or steep regions,
- for culverts that are under high fills, and
- where clean-out access is limited. However, access must be available to clean out the debris-control device.

Debris control devices should be routinely monitored and cleaned, as needed.

9.3.3 Design Limitations

9.3.3.1 Design Flood Frequency

The recommended minimum design flood frequency for culverts is shown in Figure 9.3-A.

9.3.3.2 Review Flood Frequency

The hydraulics designer should only use the review flood frequency (overtopping flood or base flood) to perform the analysis of the culvert when:

- a risk assessment or analysis of the culvert is required by 23 CFR 650.115(a), (6); or
- the culvert is located in a FEMA National Flood Insurance Program mapped floodplain (see Chapter 15 “Permits”) to confirm that the backwater caused by the culvert would not exceed 1ft over the existing base (100-year) flood elevation.

Roadway Classification	Exceedence Probability (%)	Return Period (Year)
Interstate, Freeways (Urban/Rural) ¹	2%	50
Principal Arterial	2%	50
Minor Arterial System with AADT > 3000 VPD	2%	50
Minor Arterial System with AADT ≤ 3000 VPD	4%	25
Collector System with AADT > 3000 VPD	4%	25
Collector System with AADT ≤ 3000 VPD	10%	10
Local Road System ²	20%–10%	5–10

Notes:

1. Federal regulation requires Interstate highway to be provided with protection from the two percent flood event.
2. At the discretion of the hydraulics designer, based on Risk Analysis and Design Hourly Volume (DHV).

Figure 9.3-A — RECOMMENDED MINIMUM DESIGN FLOOD FREQUENCY

9.3.3.3 Allowable Headwater

Allowable headwater is the depth of water that can be ponded at the upstream end of the culvert during the design flood. The allowable headwater for the design frequency should:

- have a level of inundation that is tolerable to upstream property and roadway for the design discharge;
- be one foot lower than the upstream shoulder edge elevation at the lowest point of the roadway within the drainage basin;
- equal to the elevation where flow diverts around the culvert; and
- equal to an HW/D no greater than 1.5.

If the allowable headwater depth to culvert height ratio (HW/D) is established to be greater than 1.5, the inlet of the culvert will be submerged. Under this condition, the hydraulics designer should provide an end treatment to mitigate buoyancy.

Allowable headwater for permanent impoundments is covered in Chapter 12 “Storage Facilities.”

9.3.3.4 Allowable Headwater for Temporary On-Site Traffic Detour

The detour should be designed for the design frequency determined using the risk rating procedure as provided in Appendix 7-A, Chapter 7 “Hydrology.” Factors in the estimation process include average daily traffic (ADT), loss of life, property damage, alternative detour length, height above streambed, drainage area and traffic interruptions. Where practical, the traffic detour profile grade should be low enough for overtopping at higher flood frequencies without creating excessive backwater. Where upstream insurable buildings could be affected, the traffic detour and drainage structures should be sized to prevent an increase in the

upstream 100-year water surface elevations over existing conditions. FEMA requirements should be met where applicable.

9.3.3.5 Tailwater Relationship (Channel)

The tailwater depth is the normal depth of the water in the downstream channel at the design discharge. A single cross section analysis to compute the tailwater depth is acceptable for most culverts. The hydraulics designer should calculate backwater curves at sensitive locations. Use the highest of the following depths as the culvert outlet depth in the culvert analysis:

- tailwater depth in the downstream channel,
- critical depth in the culvert and the approximate hydraulic gradeline, or
- headwater elevation of a downstream structure (only if the downstream structure is located close enough to have an effect on the design structure’s tailwater).

9.3.3.6 Tailwater Relationship (Confluence or Large-Water Body)

Where the culvert is located on a tributary that joins with a larger body of water (e.g., river or lake) immediately downstream, the hydraulics designer can use Figure 9.3-B to determine the frequency of the corresponding tailwater.

Drainage Area Ratio	10-year Design		100-year Design	
	Main Stream	Tributary	Main Stream	Tributary
10,000 to 1	1	10	2	100
	10	1	100	2
1000 to 1	2	10	10	100
	10	2	100	10
100 to 1	5	10	25	100
	10	5	100	25
10 to 1	10	10	50	100
	10	10	100	50
1 to 1	10	10	100	100
	10	10	100	100

Source: HDG, Chapter 9 (7)

Figure 9.3-B — EXAMPLE OF JOINT PROBABILITY ANALYSIS FOR STREAMS NEAR VIRGINIA BEACH, VA (early 1970s)

For example, a main stream (receiving waters) and tributary (culvert) have a drainage area ratio of 100 to 1, and a 10-year design is required for the culvert located on the tributary and close to the junction. Based on Figure 9.3-B, the hydraulics designer should:

- compute the normal depth of the tributary downstream of the proposed culvert for the 10-year storm, and
- compute the normal depth of the mainstream at the junction with the tributary for the 5-year storm.

The hydraulics designer should use the highest elevation (of the two normal depths above) as the tailwater elevation in the analysis of the proposed culvert.

9.3.3.7 Maximum Outlet Velocity

The hydraulics designer should consider protecting the culvert barrel from abrasion if the velocity at the culvert exit exceeds the following guidelines:

- for concrete box or pipe (40 fps),
- for concrete box with dirt bottom (12 fps)
- for metallic pipe (15 fps), and
- for plastic pipe (12 fps).

The maximum velocity at the culvert exit should be consistent with the velocity in the natural channel or should be mitigated with:

- channel stabilization (see Chapter 14 “Bank Protection”), or
- energy dissipators (see Chapter 11 “Energy Dissipators”), or both.

9.3.3.8 Minimum Culvert Velocity

The minimum velocity, at design discharge flow, should be equal to or greater than 3 fps to prevent sediment settlement in the culvert barrel.

9.3.3.9 Storage (Temporary or Permanent)

Storage is normally not considered in culvert design. If storage is being assumed upstream of the culvert, consideration should be given to:

- limiting the total area of flooding,
- limiting the average time that bankfull stage is exceeded for the design flood to 24 hours in rural areas or 6 hours in urban areas,
- performing unsteady flow (routing) analysis, and
- ensuring that the storage area will remain available for the life of the culvert through the purchase of right-of-way or easement if the culvert design depends on this storage.

9.3.3.10 Minimum Structure Cover

Desirable cover should be based upon 1-ft clearance between the top of the conduit and the lowest part of the subgrade or base course, which might receive manipulation during the compaction operations or admixture insertion, see *ODOT Roadway Design Standard Drawings*. Standard bedding materials should be Class A, B or C according to the *ODOT Specifications for Highway Construction and Supplemental Specifications*.

Desirable cover for reinforced concrete boxes should be 2 feet with a minimum of 1 foot. ODOT occasionally uses a box designed with a full load-carrying roof (at grade culvert) or minimum cover box. In this case, the minimum cover criteria will not apply.

9.4 DESIGN FEATURES

9.4.1 Culvert Shape and Material Selection

The material selected should be based on a comparison of the total cost of alternative materials over the design life of the structure, which is dependent upon the following:

- durability (service life),
- structural strength,
- hydraulic roughness,
- constructability,
- initial/replacement cost,
- bedding conditions,
- passage of fish and aquatic organisms,
- abrasion and corrosion resistance, and
- water-tightness requirements.

The most common culvert materials and shapes are:

- reinforced concrete box (RCB);
- reinforced concrete pipe: round (RCP), arch (RCPA) and elliptical (RCPE);
- corrugated steel pipe (bituminous, aluminum or mill-precoated): round, arch and elliptical;
- corrugated galvanized steel and aluminum structural plate: round pipe and various special shapes; and
- smooth or corrugated polyethylene (HDPE) and polyvinyl chloride (PVC) pipe.

Culverts can also be classified by the type of inlet: square edged, beveled or tapered (see Section 9.4.9).

9.4.2 Culvert Size

The selected culvert size and shape should be based on engineering and economic criteria related to site conditions:

- Use the following minimum sizes to avoid maintenance problems and clogging:
 - 18-in diameter or equivalent size for a cross drain,
 - 18-in diameter or equivalent size for a side drain or driveway, and
 - 3 ft × 3 ft minimum box size for a cross drain.
- Land-use requirements (e.g., need for a cattle pass) can dictate a larger or different barrel geometry than required for hydraulic considerations (see Section 9.4.4).

- Use pipe arch or oval/elliptical shapes when required by hydraulic limitations, site characteristics, structural criteria or environmental criteria.

9.4.3 Broken-Back Culverts

A broken-back culvert, which combines two different slopes, may be necessary to accommodate a large differential of flow line elevation or may result from one or more extensions to an original straight profile culvert.

9.4.4 Land-Use Culvert

A land-use culvert is a culvert designed to carry the design flood and also to provide passage under a highway for utilities, stock and wildlife animals, farmers, machinery, etc. Before designing a land-use culvert, the following should be considered:

- The land use function of these culverts will be temporarily forfeited during the selected design flood, but available during lesser floods.
- For land-use culvert with multiple openings, at least one barrel should be dry during floods less than the selected design flood.
- The land-use culvert should be sized to ensure that it can serve its intended land frequency use function up to and including a 2-year flood.
- The height and width constraints should satisfy the hydraulic or land-use requirements, whichever is larger.
- The cost savings of a land-use culvert should be weighed against the advantages of separate facilities.

9.4.5 Multiple Barrels

Multiple-barrel culverts should fit within the natural dominant channel with minor widening of the channel to avoid conveyance loss through sediment deposition in some of the barrels. The spacing between barrels should be consistent with ODOT *Roadway Design Standard Drawing* R-47. They are to be avoided where:

- the approach flow has a high velocity, particularly if supercritical (these sites require either a single barrel or special inlet treatment to avoid adverse-hydraulic jump effects);
- irrigation canals or ditches are present unless approved by the canal or ditch owner;
- fish passage is required unless special treatment is provided to ensure adequate low flows (commonly one barrel is lowered);

- the outlet of the higher barrel (sometime called relief opening) is located above the stream flow line and may need protection from headcutting and erosion problems that may undermine the outlet;
- a high potential exists for debris problems (clogging of culvert inlet); or
- a meander bend is present immediately upstream.

9.4.6 Culvert Slopes

The culvert slope should generally match the connecting channel slope, if practical. Culvert slopes can be flattened to induce sedimentation and facilitate fish passage. A zero percent slope can be used for an equalizer-type culvert in a lake or ponded area. Minimum culvert slopes should not be flatter than 0.3% if ground conditions permit. Maximum culvert slopes should not be greater than 6% for reinforced concrete pipe and 8% for corrugated metal pipe.

Where the maximum slopes are exceeded, consider dissipating excessive outlet velocities due to steep culvert slopes, see Chapter 11 “Energy Dissipators.” A concrete pipe collar should also be considered to prevent the pipe from slipping.

9.4.7 Pipe Length Measurement for Culverts

Pipe lengths are measured along the culvert flow line. For a skewed installation, plot the culvert in its actual position and scale the required length. End sections are not considered a part of the pipe length except for culvert end treatment (CET) end sections, which are constructed from field cut pipes. End sections are measured and paid for by each end section installed.

9.4.8 Skewed Installations

The degree of skew is measured as the angle between the culvert installation and a line perpendicular to the highway centerline. The degree of skew should be to the nearest 1°. Where practical, culvert installations should be designed to conform as closely as possible to the natural drainage channels. For pipe culverts, avoid excessive skews (> 30°).

Where a pipe culvert is skewed more than 5°, prepare a special cross section of its placement site. The special cross section should contain the following information:

- pipe skew;
- pipe length; and
- inlet and outlet station, offset and elevation.

9.4.9 End Treatment (Inlet or Outlet)

The culvert inlet type and the inlet coefficient (k_e) should be selected from Figure 9.14-B. Consideration should also be given to safety (see Section 9.4.10). All culverts 48-in diameter and larger should have headwalls on the inlet end to protect the culvert from buoyancy force. Buoyancy is more serious with steepness of the culvert slope, depth of the potential headwater, flatness of the upstream fill slope and height of the fill.

Projecting/mitered inlets or outlets should include anchoring the inlet to strengthen the weak, leading edge for culverts 48-in diameter and larger.

Tapered inlets should be considered only for culverts that will operate in inlet control, when practicable. Slope tapered inlet is not recommended when fish passage is required:

- When the culvert outlet flow velocity is excessive (greater than 6 fps for vegetated covered flow line or 12 fps for bedrock flow line), provide protection to downstream channel from scour and erosion problems. See Chapter 11 “Energy Dissipators” for more details.
- Wingwalls are used where the side slopes of the channel are unstable or when the culvert is skewed. Wingwalls provide the best hydraulic efficiency if the flare angle is between 30° and 60°.
- Where applicable, aprons should extend at least twice the box rise/pipe diameter upstream, but should not be more than 10 ft and should not protrude above the normal streambed elevation.
- Curtain (cutoff) wall should be used on all culverts with headwalls or slope paving. The depth of the curtain (cutoff) wall should be at least 4 ft or deeper.
- Typically, side drains utilize CET type end treatment. They are inexpensive, have the advantage of a concrete pad, are easier to maintain and can be grated within the clear zone. CET's are most often used on side drains, but can also be used on cross drains.
- PCES (Prefabricated Culvert End Section) end treatment is more economical and can be used for concrete and metal pipes. It is not as easy to maintain and should be installed outside of the clear zone. Application includes both side drains and cross drains.
- SCES (Sloped Concrete End Section) end treatment is a long, sloped and grated end section. It is typically used with concrete pipe when a more “finished” look is desirable, such as in an urban setting or when it is critical for an errant vehicle to be able to easily traverse the end treatment. It is more expensive than either the CET or the PCES.

9.4.10 Safety Considerations

Traffic should be protected from culvert ends. All culverts should be treated in one of the following ways:

- Extend culvert to outside the “clear zone” distance (8).
- Safety treat the culvert end with a grate or a safety end section to eliminate the hazard of vehicles impacting an unprotected end.
- Shield culvert end from traffic with a barrier.

Periodically inspect each site to determine if safety problems exist for traffic or for the structural safety of the culvert and embankment.

9.4.11 Median and Entrance Placement

A cross section of the placement site is prepared for each entrance or intersecting road pipe culvert. Pipes should not be installed through permanent maintenance crossovers on the Interstate. Median drainage approaching a crossover should be removed with a pipe across the mainline highway. This will provide for safer crossover inslopes.

9.4.12 Weep Holes

If weep holes are used to relieve uplift pressure, they should be designed similar to underdrain systems. The location of the weep holes should be selected carefully to avoid creating an icing hazard.

9.4.13 Performance Curves

Development of performance curves should be considered for evaluating the hydraulic capacity of a culvert where various headwaters, outlet velocities and scour depths are concerns. These curves will display the consequence of high-flow rates at the site and provide a basis for evaluating flood hazards.

9.4.14 Sag Culverts

Inverted siphons (sometimes called sag culverts or sag lines) are used to convey water by gravity under roads, railroads, other structures, various types of drainage channels and depressions. An inverted siphon is a closed conduit designed to run full and under pressure. The structure should operate without excess head when flowing at design capacity. If a sag culvert is proposed, review the design procedure and example provided in section C Inverted Siphons, Chapter 2 of the U.S. Bureau of Reclamation (USBR) Design of Small Canal Structures (9).

Economics and other considerations determine the feasibility of using an inverted siphon or another type of structure. The use of an elevated flume would be an alternative to an inverted siphon crossing such features as a deep roadway cut or another channel. The use of a raised

grade line and culvert may be a more economical alternative to employing a siphon under a road.

9.5 RELATED DESIGNS

9.5.1 Erosion and Sediment Control

Temporary measures should be included in the construction plans. These measures include the use of the following:

- silt boxes,
- straw silt barriers,
- brush silt barriers,
- filter cloth,
- temporary silt fence, and
- check dams.

For more information, see Chapter 13 “Erosion and Sediment Control.”

9.5.2 Environmental Considerations and Fishery Protection

Care must be exercised in selecting the location of the culvert site to mitigate erosion, sedimentation, debris and impact on aquatic organism passage (AOP) (4). Select a site that will permit the culvert to be constructed and will limit the impact on the stream, wetlands and AOP. For more information, see Chapter 7 “Surface Water Environment” and Chapter 8 “Wetlands” of the AASHTO *Drainage Manual* (1).

9.5.3 Irrigation Facilities

Unless legally abandoned, an irrigation structure should be required even if the irrigation canal or ditch is no longer used. The canal or ditch owner should approve the use of multiple-barrel culverts. Provision should be made to accommodate any water escaping the ditch to avoid a flood hazard. Irrigation facilities should be designed to accommodate the water and flood right using the criteria below that yields the largest culvert size:

- constrain the headwater within the existing canal or ditch banks unless provision is made for overflow during high flows,
- provide freeboard to pass expected debris,
- avoid increasing the velocity beyond what the unprotected ditch material or protection will sustain,
- avoid a flood hazard from a canal or ditch failure,
- provide a width capable of delivering the water and flood right at its existing operating depth, and
- provide for known winter ice accumulation problems.

9.5.4 Outlet Protection

Outlet protection (see Chapter 11 “Energy Dissipators”) for the selected culvert design flood should be provided where the outlet scour hole depth computations indicate:

- the scour hole will undermine the culvert outlet or roadway embankment, or both;
- the expected scour hole may cause costly property damage;
- the scour hole causes a nuisance effect (most common in urban areas);
- the scour hole blocks fish passage; or
- the scour hole will restrict land-use requirements.

9.5.5 Relief Opening

Where multiple-use culverts or culverts serving as relief openings have their outlet set above the normal stream flow line, special precautions should be required to prevent headcuts or erosion from undermining the culvert outlet.

9.6 HYDRAULIC DESIGN

9.6.1 General

An exact theoretical analysis of culvert flow is extremely complex because the following is required:

- analyzing non-uniform flow with regions of both gradually varying and rapidly varying flow;
- determining how the flow type changes as the flow rate and tailwater elevations change;
- applying backwater and drawdown calculations, energy and momentum balance;
- applying the results of hydraulic model studies; and
- determining if hydraulic jumps occur and if they are inside or downstream of the culvert barrel.

Most of the above complications are addressed in the software HY-8 (see Chapter 16 “Hydraulic Software”). The following discussion provides the basic equations that are used by HY-8 and other culvert analysis software.

9.6.2 ODOT Standard Practice

HDS-5 (2) is the standard practice for the hydraulic design of culverts. The hydraulics designer has the option of performing an analysis using the equations outlined in this chapter, using the nomographs in Section 9.14 or using software that is consistent with the equations provided in HDS-5 (see Chapter 16 “Hydraulic Software”).

The following standard practices apply to culverts:

- All culverts should be hydraulically designed.
- The overtopping flood selected should be consistent with the class of highway and appropriate for the risk at the site (see Section 9.3 Design Criteria).
- Survey information should include topographic features, channel characteristics, aquatic life, high-water information, existing structures and other related site-specific information. Refer to Chapter 5 “Data Collection.”
- Culvert location in both plan and profile should be investigated to minimize the potential for sediment buildup in culvert barrels.
- The cost savings of multiple uses (utilities, stock and wildlife passage, land access and fish passage) should be weighed against the advantages of separate facilities.

- Culverts should be designed to accommodate debris or appropriate provisions should be made for debris maintenance.
- Material selection should include consideration of service life that includes abrasion and corrosion.
- Culverts should be located and designed to present a minimum hazard to traffic and people.
- The detail of documentation for each culvert site should be appropriate for the risk and importance of the structure. Design data and calculations should be assembled in an orderly fashion and retained for future reference as provided for in Chapter 6 “Documentation.”
- Where practical, some means should be provided for personnel and equipment access to facilitate maintenance.

9.6.2.1 Design Discharge

The design discharge used in the design of the culvert should be the peak discharge produced by the design frequency. This will yield a conservatively sized structure where temporary storage is available but not used. The storage can be assessed using the procedures in Section 9.10.

9.6.2.2 Hydraulics Control Section

The hydraulics control section is the location where there is a unique relationship between the flow rate and the upstream water surface elevation. Inlet control is governed by the inlet geometry. Outlet control is governed by a combination of the culvert inlet geometry, the barrel characteristics and the tailwater or critical depth.

9.6.2.3 Minimum Performance

Minimum performance is assumed by analyzing both inlet and outlet control and using the highest headwater. The culvert may operate more efficiently at times (more flow for a given headwater level), but it will not operate at a lower level of performance than calculated.

9.6.3 Inlet Control

Figure 9.6-A (2) illustrates the types of inlet control flow. The inlet control flow type depends on the submergence of the inlet and outlet ends of the culvert. In all of these examples, the control section is at the inlet end of the culvert. Depending on the tailwater, a hydraulic jump may occur downstream of the inlet.

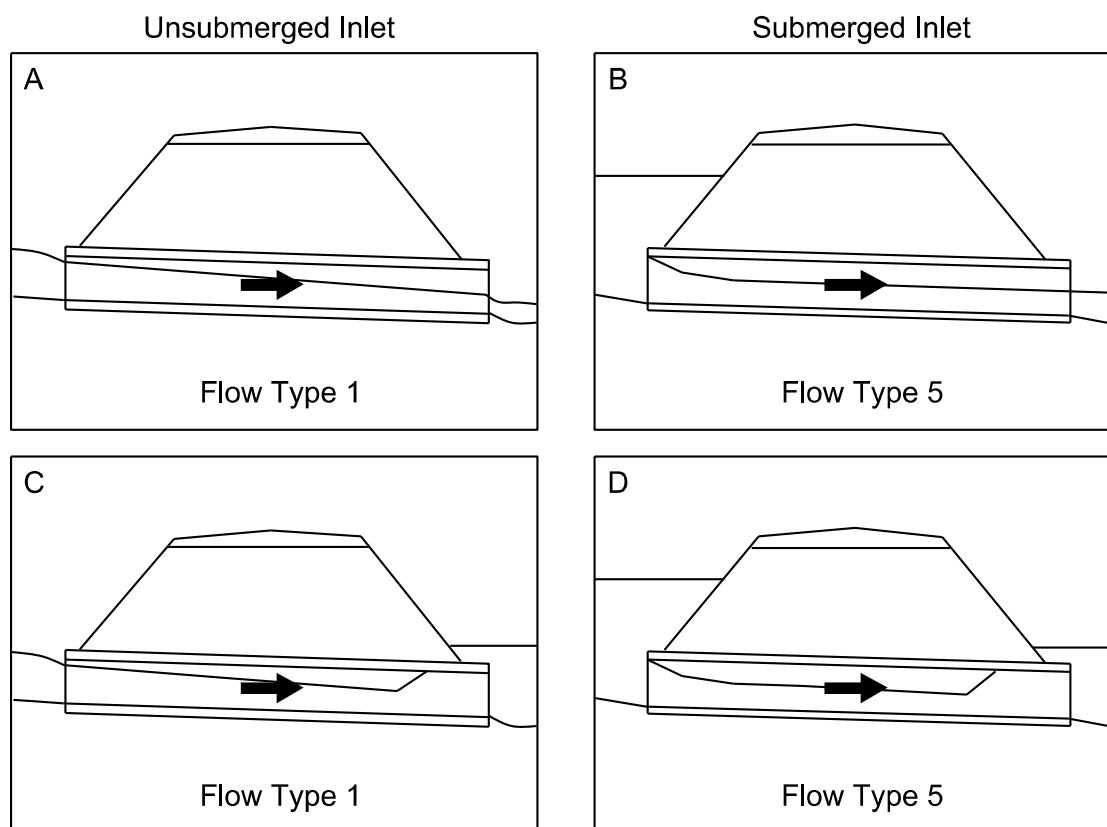

Source: HDS-5 (2)

Figure 9.6-A — TYPES OF INLET CONTROL

9.6.3.1 Factors Influencing Inlet Control

Because the control is at the upstream end, only the headwater and the inlet factors affect the culvert performance:

- Headwater depth is measured from the invert of the inlet control section to the surface of the upstream pool.
- Inlet area is the cross-sectional area of the face of the culvert. Generally, the inlet face area is the same as the barrel area, but for tapered inlets (Section 9.11) the face area is enlarged and the control section is at the throat.
- Inlet configuration describes the entrance type. Some typical inlet configurations are thin edge projecting, mitered, square edges in a headwall and beveled edge.
- Inlet shape is usually the same as the shape of the culvert barrel; however, it may be enlarged as in the case of a tapered inlet. Typical shapes are rectangular, circular and elliptical. Whenever the inlet face is a different size or shape than the culvert barrel, the possibility of an additional control section within the barrel exists.

- Barrel slope influences inlet control performance, but the effect is small. Inlet control nomographs assume a slope of 2% for the slope correction term (0.5S for most inlet types). This results in lowering the headwater required by 0.01D. In the computer program HY-8, the actual slope is used as a variable in the calculation.

9.6.3.2 Hydraulics

Inlet control performance is defined by the three regions of flow shown in Figure 9.6-B: unsubmerged, transition and submerged. For low headwater conditions, as shown in Figure 9.6-A (A) and Figure 9.6-A (C), the entrance of the culvert operates as a weir. A weir is an unsubmerged flow control section where the upstream water surface elevation can be predicted for a given flow rate. The relationship between flow and water surface elevation must be determined by model tests of the weir geometry or by measuring prototype discharges. These tests or measurements are then used to develop equations for unsubmerged inlet control flow. HDS-5, Appendix A (2) contains the equations which were developed from the National Bureau of Standards (NBS) and other model test data.

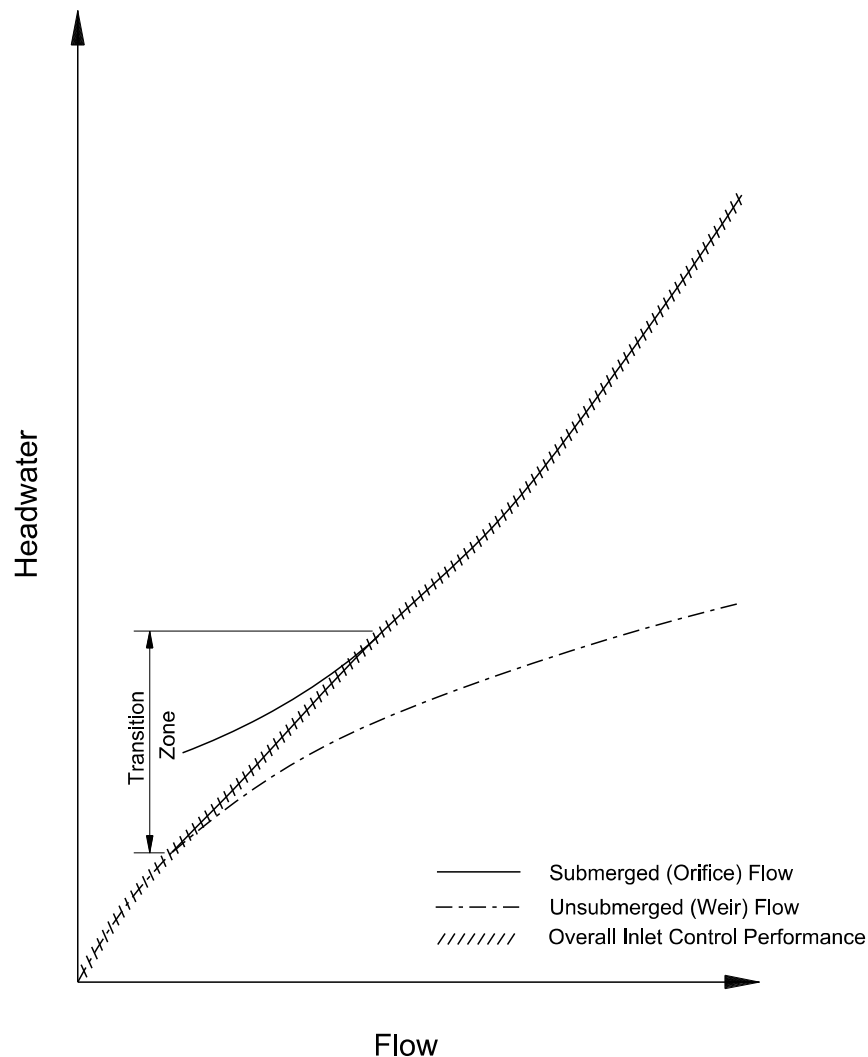

Figure 9.6-B — INLET CONTROL CURVES

For headwaters submerging the culvert entrance, as shown in Figure 9.6-A (B) and Figure 9.6-A (D), the entrance of the culvert operates as an orifice. An orifice is an opening, submerged on the upstream side and flowing freely on the downstream side, which functions as a control section. The relationship between flow and headwater can be defined based on results from model tests (see HDS-5 (2)).

The flow transition zone between the low headwater (weir control) and the high headwater (orifice control) flow conditions is poorly defined. This zone is approximated by plotting the unsubmerged and submerged flow equations and connecting them with a line tangent to both curves, as shown in Figure 9.6-B.

The inlet control flow versus headwater curves which are established using the above procedure are the basis for constructing the inlet control design nomographs and for developing equations used in software. The original equations for computer software were generally 5th order polynomial curve fitted equations that were developed to be as accurate as the nomograph solution (plus or minus 10%) within the headwater range of 0.5D to 3.0D. These equations are still being used in HY-8, but have been supplemented with a weir equation from 0.0D to 0.5D and an orifice equation above 3.0D.

9.6.3.3 Inlet Depression

Inlet depression is created by constructing the entrance inlet below the streambed. The amount of inlet depression is defined as the depth from the natural streambed at the face to the inlet invert. The inlet control equations or nomographs provide the depth of headwater above the inlet invert required to convey a given discharge through the inlet. This relationship remains constant regardless of the elevation of the inlet invert. If the entrance end of the culvert is constructed below the streambed, more head can be exerted on the inlet for the same headwater elevation.

9.6.4 Outlet Control

Figure 9.6-C (2) illustrates the types of outlet control flow. The outlet control flow type depends on the submergence of the inlet and outlet ends of the culvert. In all cases, the control section is at the outlet end of the culvert or further downstream. For the partly full flow situations, the flow in the barrel is subcritical.

9.6.4.1 Factors Influencing Outlet Control

Since the control is at the downstream end, the headwater is influenced by all of the culvert factors. The inlet factors influencing the performance of a culvert in inlet control also influence culverts in outlet control (see Section 9.6.3). In addition, the barrel characteristics (roughness, area, shape, length and slope) and the tailwater elevation affect culvert performance in outlet control:

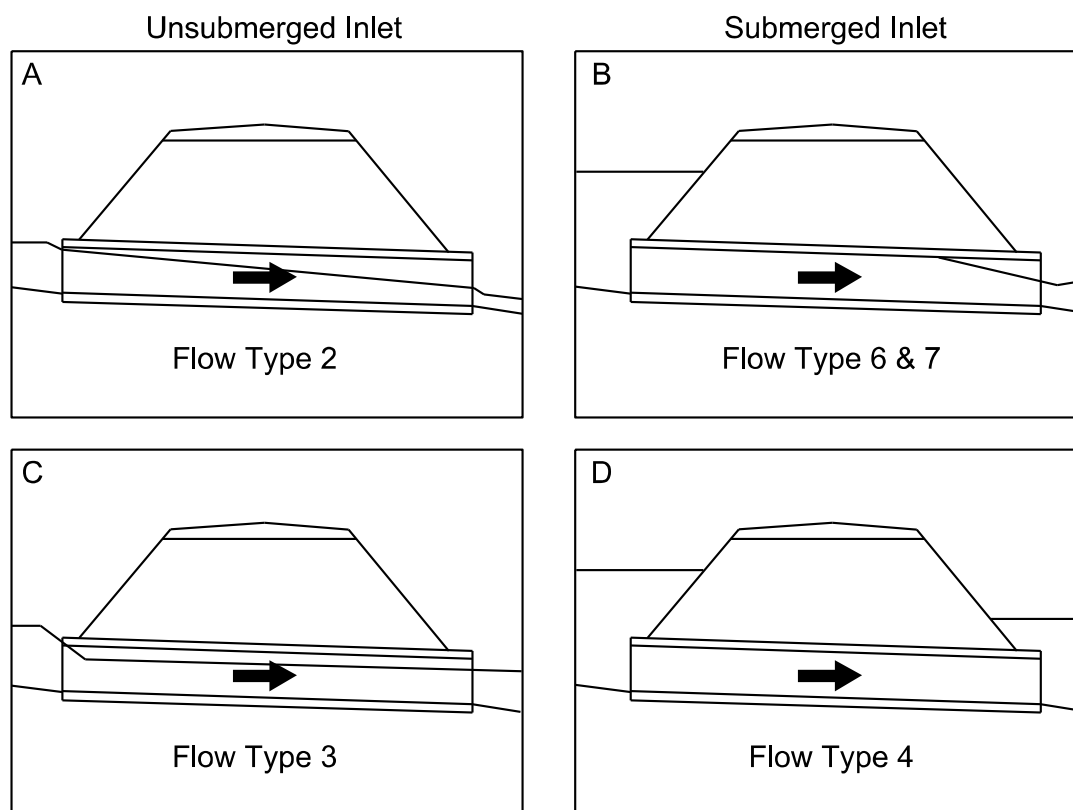

Source: HDS-5 (2)

Figure 9.6-C — TYPES OF OUTLET CONTROL

- Barrel roughness is a function of the material used to fabricate the barrel. Typical materials include concrete, corrugated metal and plastic. The roughness is represented by a hydraulic resistance coefficient such as the Manning’s *n* value. Typical Manning’s *n* values used for designing culverts are as shown in Table 9.14-A.
- Barrel area is a function of the culvert dimensions. A larger barrel area will convey more flow.
- Barrel shape is a function of culvert type and material. Based on the location of the center of gravity for a given area, a box is the most efficient shape, then the arch shape, followed by the circular shape.
- Barrel length is the total culvert length from the entrance to the exit of the culvert. Because the design height of the barrel and the slope influence the actual length, an approximation of barrel length is usually necessary to begin the design process.
- Barrel slope is the actual slope of the culvert barrel. The barrel slope is often the same as the natural stream slope. However, when the culvert inlet is raised or lowered, the barrel slope is different from the stream slope. The slope is not a factor in calculating the barrel losses for Flow Types 4, 6 and 7; but is a factor for in calculating Flow Types 2 and 3 when a water surface profile is calculated.

- Tailwater elevation is based on the downstream water surface elevation. Backwater calculations from a downstream control, a normal depth approximation or field observations are used to define the tailwater elevation.

9.6.4.2 Hydraulics (Full Barrel Flow)

Full flow in the culvert barrel, as depicted in Figure 9.6-C (D), is the best flow type for describing the hand computation of outlet control hydraulics. Outlet control flow conditions can be calculated based on an energy balance from the tailwater pool to the headwater pool. The total energy (H_L) required to pass the flow through the culvert barrel is made up of the entrance loss (H_e), the friction losses through the barrel (H_f) and the exit loss (H_o). Other losses, including bend losses (H_b), losses at junctions (H_j) and losses at grates (H_g) should be included as appropriate. These other losses are discussed in Chapter 5 of HDS-5.

$$H_L = H_e + H_f + H_o + H_b + H_j + H_g \quad \text{Equation 9.6(1)}$$

Where:

- H_L = total energy losses, ft
- H_e = entrance headloss, ft
- H_f = friction headloss, ft
- H_o = exit headloss, ft
- H_b = bend headloss, ft
- H_j = headloss at junction, ft
- H_g = headloss at grate, ft

The barrel velocity is calculated as follows:

$$V = Q / A \quad \text{Equation 9.6(2)}$$

Where:

- V = average barrel velocity, fps
- Q = flow rate, cfs
- A = cross sectional area of flow with the barrel full, ft²

The velocity head is:

$$H_v = \frac{V^2}{2g} \quad \text{Equation 9.6(3)}$$

Where:

- g = acceleration due to gravity, 32.2 ft²/s

The entrance loss is a function of the velocity head in the barrel, and can be expressed as a coefficient times the velocity head:

$$H_e = k_e \left(\frac{V^2}{2g} \right) \quad \text{Equation 9.6(4a)}$$

Where:

k_e = entrance loss coefficient (see Section 9.14, Figure 9.14-B)

The friction loss in the barrel is also a function of the velocity head. Based on the Manning equation, the friction loss is:

$$H_f = \left[\frac{(29n^2L)}{R^{1.33}} \right] \left[\frac{V^2}{2g} \right] \quad \text{Equation 9.6(4b)}$$

Where:

n = Manning's roughness coefficient for a culvert with uniform material on the full perimeter (for composite roughness (n_c) (see Section 9.14, Figure 9.14-A)
 L = length of the culvert barrel, ft
 A = cross-sectional area of the barrel, ft²
 R = hydraulic radius of the full culvert barrel = A/P , ft
 P = wetted perimeter of the barrel, ft
 V = velocity in the barrel, fps

The exit loss is a function of the change in velocity at the outlet of the culvert barrel. For a sudden expansion such as an endwall, the exit loss is:

$$H_o = 1.0 \left[\left(\frac{V^2}{2g} \right) - \left(\frac{V_d^2}{2g} \right) \right] \quad \text{Equation 9.6(4c)}$$

Where:

V_d = channel velocity downstream of the culvert, fps

Equation 9.6(4c) may overestimate exit losses, and a multiplier of less than 1.0 can be used (see HEC-14 (10)) for a transition loss. The downstream velocity is usually neglected, in which case the exit loss is equal to the full flow velocity head in the barrel, as shown in Equation 9.6(4d).

$$H_o = H_v = \frac{V^2}{2g} \quad \text{Equation 9.6(4d)}$$

Equation 9.6(4d) is the standard option in HY-8. If the hydraulics designer chooses the Utah State University (USU) Method (which is the alternate in HY-8), the following equation will be used:

$$H_o = \frac{(V - V_d)^2}{2g} \tag{Equation 9.6(4e)}$$

Inserting the above relationships for entrance loss, friction loss and exit loss (Equation 9.6(4d)) into Equation 9.6(1), the following equation for barrel losses (H) is obtained:

$$H = \left[1 + k_e + \left(\frac{29n^2L}{R^{1.33}} \right) \right] \left[\frac{V^2}{2g} \right] \tag{Equation 9.6(5)}$$

9.6.4.3 Energy Grade Line

Figure 9.6-D depicts the energy grade line and the hydraulic grade line for full flow in a culvert barrel. The energy grade line represents the total energy at any point along the culvert barrel. The headwater depth HW_o is the depth from the inlet invert to the energy grade line. The hydraulic grade line is the depth to which water would rise in vertical tubes connected to the sides of the culvert barrel. In full flow, the energy grade line and the hydraulic grade line are parallel straight lines separated by the velocity head except in the vicinity of the inlet where the flow passes through a contraction. The headwater and tailwater conditions as well as the entrance, friction and exit losses are also shown in Figure 9.6-D. Equating the total energy at Sections 1 and 2, upstream and downstream of the culvert barrel in Figure 9.6-D, the following relationship results:

$$HW_o + LS + \frac{V_u^2}{2g} = TW + \frac{V_d^2}{2g} + H_L \tag{Equation 9.6(6a)}$$

Where:

- HW_o = headwater depth above the outlet invert, ft
- V_u = approach velocity, fps
- TW = tailwater depth above the outlet invert, ft
- V_d = downstream velocity, fps
- H_L = sum of all losses (see Equation 9.6(1))
- LS = drop through the culvert, ft

Note: The total available upstream headwater (HW_o) includes the depth of the upstream water above the inlet invert and the approach velocity head. In most instances, the approach velocity is low and the approach velocity head is neglected. However, it can be considered to be a part of the available headwater and used to convey the flow through the culvert.

Likewise, the velocity downstream of the culvert (V_d) is usually neglected. When both approach and downstream velocities are neglected, Equation 9.6(6a) becomes:

$$HW_o = TW + H_L - LS \tag{Equation 9.6(6b)}$$

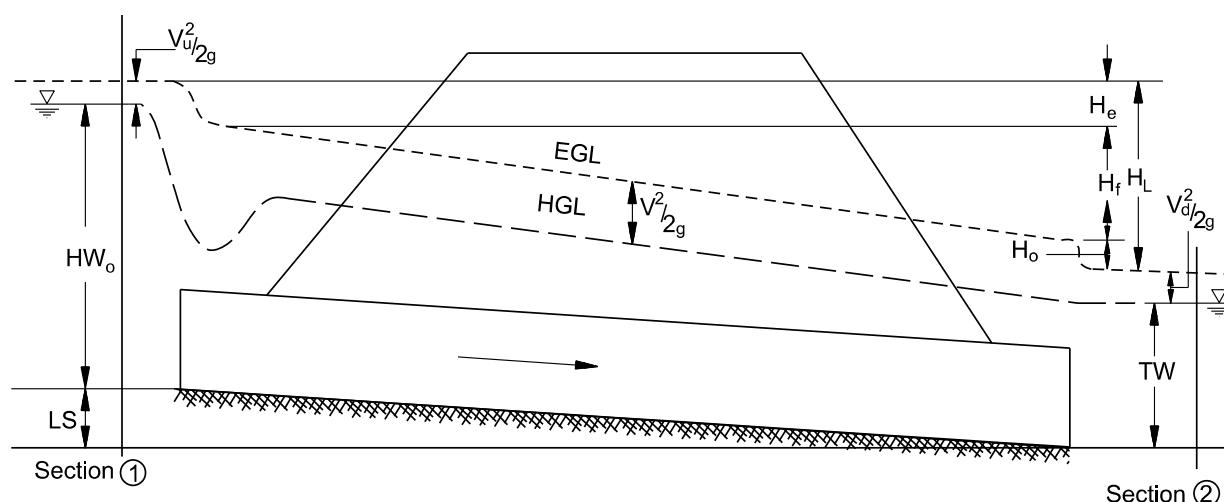

Source: HDS-5 (2)

Figure 9.6-D — FULL FLOW ENERGY AND HYDRAULIC GRADE LINES

9.6.4.4 HDS-5 Nomographs (Full Flow)

The nomographs were developed assuming that the culvert barrel is flowing full and:

- $TW \geq D$, Flow Type 4 (see Figure 9.6-C (D)); or
- $d_c \geq D$, Flow Type 6 (see Figure 9.6-C (B)).

V_u is small and its velocity head can be considered to be a part of the available headwater (HW_o) used to convey the flow through the culvert. V_d is small and its velocity head can be neglected. Equation 9.6(6b) is used with the outlet control nomographs to determine outlet control headwater (HW_o).

9.6.4.5 HDS-5 Nomographs (Partial Full Flow) — Approximate Method

Based on numerous backwater calculations performed by the FHWA staff, it was found that the hydraulic grade line pierces the plane of the culvert outlet at a point approximately $1/2$ of the way between critical depth and the top of the barrel or $(d_c + D)/2$ above the outlet invert. The approximation should only be used if the barrel flows full for part of its length or the headwater is at least $0.75D$. If neither of these conditions is met, a water surface profile should be used to establish the hydraulic grade line. TW should be used if higher than $(d_c + D)/2$. The following equation should be used:

$$HW = h_o + H - S_oL \quad \text{Equation 9.6(6c)}$$

Where:

h_o = the larger of TW or $(d_c + D)/2$, ft

9.6.5 Outlet Velocity

Culvert outlet velocities should be calculated to determine the need for erosion protection at the culvert exit. Culverts usually result in outlet velocities that are higher than the natural stream velocities. These outlet velocities may require flow readjustment or energy dissipation to prevent downstream erosion. If outlet erosion protection is necessary, the flow depths and Froude number may also be needed (see Chapter 11 “Energy Dissipators”).

9.6.5.1 Inlet Control

The velocity is calculated from Equation 9.6(2) after determining the outlet depth. Either of the following methods may be used to determine the outlet depth:

- Calculate the water surface profile through the culvert. Begin the computation at d_c at the entrance and proceed downstream to the exit. Determine at the exit the depth and flow area.
- Assume normal depth and velocity. This approximation may be used because the water surface profile converges towards normal depth if the culvert is of adequate length. This outlet velocity may be slightly higher than the actual velocity at the outlet. Normal depth may be obtained by hand computation or by software (e.g., FHWA Hydraulic Toolbox).

9.6.5.2 Outlet Control

The cross sectional area of the flow is defined by the geometry of the outlet and either critical depth, tailwater depth or the height of the conduit:

- Critical depth is used where the tailwater is less than critical depth.
- Tailwater depth is used where tailwater is greater than critical depth but below the top of the barrel.
- The total barrel area is used where the tailwater exceeds the top of the barrel.

9.6.6 Roadway Overtopping

Roadway overtopping will begin when the headwater rises to the elevation of the roadway. The overtopping will usually occur at the low point of a sag vertical curve on the roadway. The flow will be similar to flow over a broad-crested weir. Flow coefficients for flow overtopping roadway embankments are found in Section 11.10, Figure 9.14-R (Chart 60B):

$$Q_o = C_d L H W_r^{1.5} \quad \text{Equation 9.6(7)}$$

Where:

- Q_o = overtopping flow rate, cfs
- C_d = overtopping discharge coefficient (weir coefficient) = $k_t C_r$
- k_t = submergence coefficient from Figure 9.14-R
- C_r = discharge coefficient from Figure 9.14-R
- L = length of the roadway crest, ft
- HW_r = the upstream depth, measured above the roadway crest, ft

9.6.6.1 Roadway Crest Length

The length is difficult to determine where the crest is defined by a roadway sag vertical curve:

1. Recommend subdividing into a series of segments. The flow over each segment is calculated for a given headwater. The flows for each segment are added together to determine the total flow.
2. The length can be represented by a single horizontal line (one segment). The length of the weir is the horizontal length of this segment. The depth is the average depth (area/length) of the upstream pool above the roadway.

9.6.6.2 Total Flow

Total flow is calculated for a given upstream water surface elevation using Equation 9.7(2):

- Roadway overflow plus culvert flow must equal total design flow.
- A trial-and-error process is necessary to determine the flow passing through the culvert and the amount flowing across the roadway.
- Performance curves for the culvert and the road overflow may be summed to yield an overall performance.

9.6.7 Performance Curves

Performance curves are plots of flow rate versus headwater depth or elevation, velocity or outlet scour. The culvert performance curve consists of the controlling portions of the individual performance curves for each of the following control sections (see Figure 9.6-E):

- The inlet performance curve is developed using the inlet control nomographs.
- The outlet performance curve is developed using Equations 9.6(1) through 9.6(7), the outlet control nomographs or backwater calculations.
- The roadway performance curve is developed using Equation 9.7(2).

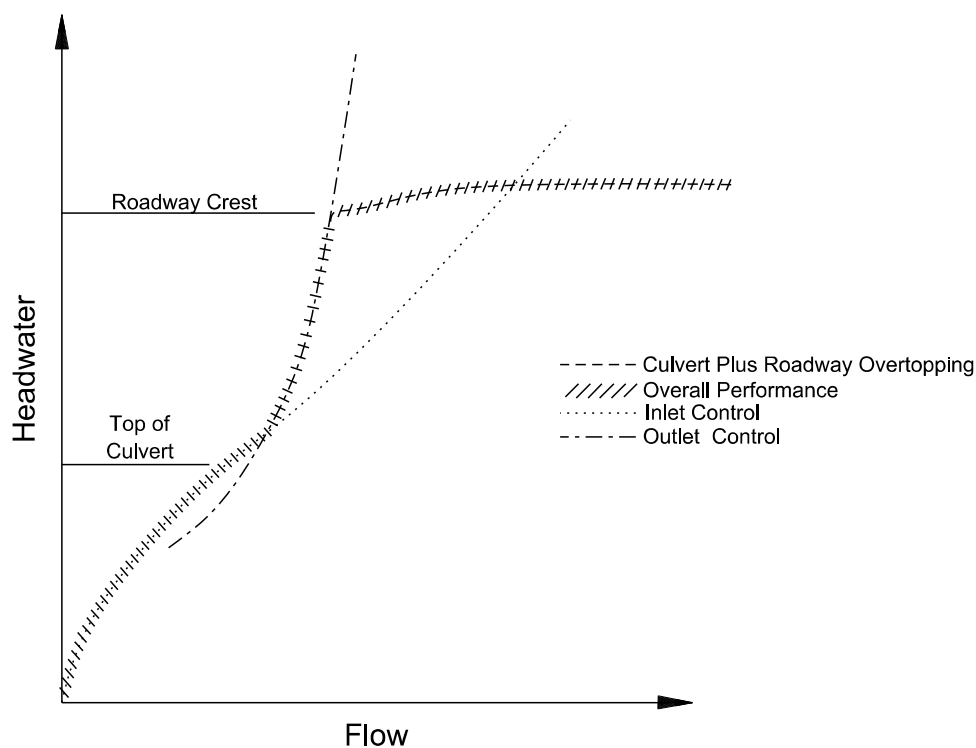

Figure 9.6-E — OVERALL PERFORMANCE CURVE

The overall performance curve is the sum of the flow through the culvert and the flow across the roadway. The curve can be determined by performing the following steps:

- Step 1. Select a range of flow rates and determine the corresponding headwater elevations for the culvert flow alone. These flow rates should fall above and below the design discharge and cover the entire flow range of interest. Both inlet and outlet control headwaters should be calculated.
- Step 2. Combine the inlet and outlet control performance curves to define a single performance curve for the culvert.
- Step 3. When the culvert headwater elevations exceed the roadway crest elevation, overtopping will begin. Calculate the upstream water surface depth above the roadway for each selected flow rate. Use these water surface depths and Equation 9.6(7) to calculate flow rates across the roadway.
- Step 4. Add the culvert flow and the roadway overtopping flow at the corresponding headwater elevations to obtain the overall culvert performance curve as shown in Figure 9.6-E.

9.6.8 Culvert Design Form

The Culvert Design Form, shown in Figure 9.6-F, has been formulated to guide the user through the design process. A full size form is provided as Figure 9.14-S. Summary blocks are provided at the top of the form for the project description and the hydraulics designer's identification. Summaries of hydrologic data of the form are also included. At the top right is a small sketch of the culvert with blanks for inserting important dimensions and elevations.

PROJECT: _____		STATION: _____		CULVERT DESIGN FORM								
		SHEET _____ OF _____		DESIGNER / DATE: _____ / _____								
				REVIEWER / DATE: _____ / _____								
HYDROLOGICAL DATA				<p style="text-align: center;"> $S = S_o - T/L_o$ $S =$ _____ $L_o =$ _____ </p>								
See Adj. Shts. <input type="checkbox"/> METHOD: _____ <input type="checkbox"/> DRAINAGE AREA: _____ <input type="checkbox"/> STREAM SLOPE: _____ <input type="checkbox"/> CHANNEL SHAPE: _____ <input type="checkbox"/> ROUTING: _____ <input type="checkbox"/> OTHER: _____												
DESIGN FLOWS/TAILWATER												
R.I. (YEARS)	FLOW (cfs)	TW (ft)										
_____	_____	_____										
CULVERT DESCRIPTION:		HEADWATER CALCULATIONS										
MATERIAL - SHAPE - SIZE - ENTRANCE	Total Flow Q (cfs)	Flow Per Barrel Q / N (1)	INLET CONTROL			OUTLET CONTROL				Control Headwater Elevation	Outlet Velocity	Comments
			HW/D (2)	HW _i	T (3)	EL _{hi} (4)	TW (5)	d	$\frac{d_o + D}{2}$			
TECHNICAL FOOTNOTES:												
(1) USE Q/NB FOR BOX CULVERTS			(4) EL _{hi} = HW _i + EL (INVERT OF INLET CONTROL SECTION)			(6) h _o = TW or (d _o + D) / 2 (WHICHEVER IS GREATER)						
(2) HW _i / D = HW / D OR HW _i / D FROM DESIGN CHARTS			(5) TW BASED ON DOWN STREAM CONTROL OR FLOW DEPTH IN CHANNEL			(7) H = [1 + k _e + (K _o n ² L) / R ^{1.33}] √ / 2g WHERE Ku = 19.63 (29 IN ENGLISH UNITS)						
(3) T = HW _i - (EL _{hi} - EL _o) T IS ZERO FOR CULVERTS ON GRADE			(8) EL _{ho} = EL _o + H + h _o									
SUBSCRIPT DEFINITIONS:			COMMENTS / DISCUSSION:				CULVERT BARREL SELECTED:					
a. APPROXIMATE f. CULVERT FACE ha. ALLOWABLE HEADWATER hi. HEADWATER IN INLET CONTROL ho. HEADWATER IN OUTLET CONTROL i. INLET CONTROL SECTION o. OUTLET sf. STREAMBED AT CULVERT FACE tw. TAILWATER							SIZE: _____ SHAPE: _____ MATERIAL: _____ n _____ ENTRANCE: _____					

Figure 9.6-F — CULVERT DESIGN FORM

9.7 DESIGN PROCEDURE

The following design procedure provides a convenient and organized method for designing culverts for a constant discharge, considering inlet and outlet control. The procedure does not address the effect of storage, which is discussed in the Chapter 12 “Storage Facilities” and Section 9.10. The hydraulics designer should be familiar with all the equations in Section 9.6 before using these procedures. Following the design method without an understanding of culvert hydraulics can result in an inadequate, unsafe or costly structure.

The Culvert Design Form (see Figure 9.6-F) is provided to guide the user. It contains blocks for the project description, hydraulics designer’s identification, hydrologic data, culvert dimensions and elevations, trial culvert description, inlet and outlet control HW, culvert barrel selected and comments.

Step 1. Assemble site data and project file.

- See Chapter 5 “Data Collection”—The minimum data are:
 - USGS, site and location maps;
 - roadway embankment cross section;
 - stream cross sections;
 - roadway profile;
 - photographs;
 - field visit (sediment, debris); and
 - design data at nearby structures.
- Studies by other agencies including:
 - small dams—NRCS, USACE, TVA, BLM;
 - canals—NRCS, USACE, TVA, USBR;
 - floodplain—NRCS, USACE, TVA, FEMA, USGS, NOAA; and
 - storm drain—local or private.
- Environmental constraints (see Chapter 15 “Permits”) including:
 - commitments contained in review documents,
 - aquatic organism passage, and
 - wildlife passage.
- Design criteria:
 - review Section 9.3 for applicable criteria, and
 - prepare risk assessment or analysis.

Step 2. Determine hydrology.

- See Chapter 7 “Hydrology.”
- Minimum data are drainage area map and a discharge-frequency plot.

Step 3. Design downstream channel.

- See Chapter 8 “Channels.”
- Minimum data are cross section of channel and the rating curve for channel.

Step 4. Summarize data on Culvert Design Form.

- See Figure 9.6-F.
- Data from Steps 1-3.

Step 5. Determine the first trial size, material, shape and entrance type of culvert.

See Section 9.4, Design Features.

- a. By arbitrary selection, the hydraulics designer can choose the first trial size referring to the roadway opening, the stream width or the stream depth.
- b. For straight culvert design (no depression or tapered inlets), the first trial culvert size can be determined by:

(1) Using an approximating equation: $Q/10 = A$

Where Q = design discharge, cfs
 A = culvert area, ft²

Another approximating equation is:

$$B = (Q/AHW)^{1/2}$$

Where: Q = design discharge, cfs
 AHW = allowable highwater depth
 B = box span width, ft.
 D = box span height, ft. = B/2
 D = pipe diameter, ft.

(2) Using inlet control nomographs: For a given flow discharge Q, the hydraulics designer will assume a value of the ratio HW/D to determine the dimension of the trial size culvert.

- c. For tapered inlet design, the first trial culvert size can be determined by using outlet control nomographs as follows:

(1) Assume a culvert height D.

(2) Intersect the “Turning Line” with a line drawn between Discharge, Q and Head, H. To estimate H, use the following equation:

$$H = AHW \text{ EL.} - \text{Outlet invert} - h_o$$

Where: AHW EL is the maximum allowable highwater elevation, h_o can be selected as culvert height D. Accuracy is not critical at this point.

- (3) Using the intersection point on the "Turning Line," the entrance loss coefficient K_e and the culvert length, draw a line defining the culvert size.

Step 6. Select design discharge (Q_d).

- a. See Section 9.3, Design Criteria.
- b. Determine flood frequency from design criteria.
- c. Determine Q from discharge-frequency plot (Step 2).
- d. Divide Q by the number of barrels.

Step 7. Determine inlet control headwater depth (HW_i).

Use the inlet control nomograph. Note: A plastic sheet with a matte finish can be used to mark on so that the nomographs can be preserved. Since headwater depth is above the invert, T (see Figure 9.6-F) should be considered if there is a depression at the inlet.

- a. Locate the size or height on the scale.
- b. Locate the discharge:
 - For a circular shape, use discharge.
 - For a box shape, use Q per foot of width.
- c. Locate HW/D ratio:
 - Use a straight edge.
 - Extend a straight line from the culvert size through the flow rate.
 - Mark the first HW/D scale. Extend a horizontal line to the desired scale and read HW/D and note on the Culvert Design Form.
- d. Calculate headwater depth (HW_i):
 - Multiply HW/D by D to obtain HW to energy grade line.
 - Neglecting the approach velocity, $HW_i = HW$.
 - Including the approach velocity, $HW_i = HW - \text{approach velocity head}$.

Step 8. Determine outlet control headwater depth at inlet (HW_o).

- a. Calculate the tailwater depth (TW) using the design flow rate and normal depth (single section) or using a water surface profile.
- b. Calculate critical depth (d_c):

Locate flow rate and read d_c .

d_c cannot exceed D .

If $d_c > 0.9D$, consult Handbook of Hydraulics (11) for a more accurate d_c , if needed, because curves are truncated where they converge.

c. Calculate $(d_c + D)/2$.

d. Determine (h_o) :

$h_o =$ the larger of TW or $(d_c + D)/2$.

e. Determine (k_e) :

Entrance loss coefficient from Section 9.14, Figure 9.14-B.

f. Determine losses through the culvert barrel (H) :

- Use nomograph or Equation 9.6(5) or 9.6(6) if outside range.
- Locate appropriate k_e scale.
- Locate culvert length (L) or (L_1) :
 - use (L) if Manning's n matches the n value of the culvert, and
 - use (L_1) to adjust for a different culvert n value:

$$L_1 = L(n_1 / n)^2 \quad \text{Equation 9.7(1)}$$

Where:

L_1 = adjusted culvert length, ft
 L = actual culvert length, ft
 n_1 = desired Manning n value
 n = Manning n value on chart

- Mark point on turning line:
 - use a straight edge, and
 - connect size with the length.
- Read (H) :
 - use a straight edge,
 - connect Q and turning point, and
 - Read (H) on Head Loss scale.

g. Calculate outlet control headwater (HW_{oi}) :

- Use Equation 9.6(6); if V_u and V_d are neglected:

$$HW_{oi} = H + h_o - S_o L$$

- Use Equations 9.7(1), 9.6(4c) and 9.6(6a) to include V_u and V_d .
- If HW_o is less than $1.2D$ and control is outlet control, the barrel may flow partly full:
 - If the headwater depth falls below $0.75D$, the approximate nomograph method should not be used and the approximate method of using the greater of tailwater or $(d_c + D)/2$ may not be applicable.
 - Backwater calculations should be used to determine the headwater.

Step 9. Determine controlling headwater (HW_c).

- Compare HW_i and HW_o ; use the higher.
- $HW_c = HW_i$, if $HW_i > HW_o$
- Where practicable, some means shall be provided for personnel and equipment access to facilitate maintenance.
- Culverts shall be regularly inspected and maintained.

Step 10. Compute discharge over the roadway (Q_o).

- Calculate depth above the roadway (HW_r):
 - $HW_r = HW_c - HW_{ov}$.
 - HW_{ov} = height of road above inlet invert.
- If $HW_r \leq 0$, $Q_o = 0$
If $HW_r > 0$, determine C_d from Section 9.14, Figure 9.14-R (Chart 60B).
- Determine length of roadway crest (L).
- Calculate Q_o using Equation 9.6(7):

$$Q_o = C_d L H W_r^{1.5}$$

Step 11. Compute total discharge (Q_t).

$$Q_t = Q_d + Q_o \quad \text{Equation 9.7(2)}$$

Step 12. Calculate outlet velocity (V_o) and depth (d_n).

If inlet control is the controlling headwater

- a. Calculate flow depth at culvert exit:
 - use normal depth (d_n), or
 - use water surface profile.
- b. Calculate flow area (A).
- c. Calculate exit velocity (V_o) = Q/A .

If outlet control is the controlling headwater

- a. Calculate flow depth at culvert exit
 - use (d_c) if $d_c > TW$.
 - use (TW) if $d_c < TW < D$.
 - use (D) if $D < TW$.
- b. Calculate flow area (A).
- c. Calculate exit velocity (V_o) = Q/A .

Step 13. Review results.

Compare alternative design with constraints and assumptions. If any of the following are exceeded, repeat Steps 5 through 12:

- the barrel must have adequate cover,
- the length shall be close to the approximate length,
- the headwalls and wingwalls must fit site,
- the allowable headwater shall not be exceeded, and
- the allowable overtopping flood frequency shall not be exceeded.

Step 14. Plot performance curve.

- a. Repeat Steps 6 through 12 with a range of discharges.
- b. Use the following upper limit for discharge (Q_o = overtopping flow):
 - Q_{100} , if $Q_o \leq Q_{100}$.
 - Q_{500} , if $Q_o > Q_{100}$.

- Q_{\max} = largest flood that can be estimated, if no overtopping is possible

Step 15. Consider the following options:

- tapered inlets if culvert is in inlet control and has limited available headwater (see Section 9.11);
- flow routing if a large upstream headwater pool exists (see Section 9.10);
- energy dissipators if V_o is larger than the normal V in the downstream channel (see Chapter 11 “Energy Dissipators”);
- debris control storage for sites with sediment concerns (e.g., alluvial fans) or with other debris concerns (see HEC-9 (5) and Chapter 13 “Erosion and Sediment Control”);
- fish passage or aquatic organism passage (see Section 9.13); and
- broken-back culverts (see Section 9.12).

Step 16. Documentation.

- See Chapter 6 “Documentation;”
- see Section 9.9 Documentation; and
- prepare report and file with background information.

9.8 DESIGN EXAMPLE USING NOMOGRAPHS

The following example problem follows the design procedure steps described in Section 9.7:

Step 1. Assemble site data and project file.

- Site survey project file contains
 - USGS, site and location maps;
 - roadway profile; and
 - embankment cross section.

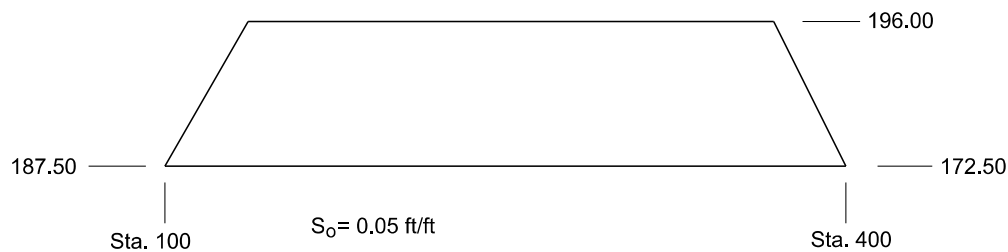

- Site visit notes indicate:
 - no sediment or debris problems, and
 - no nearby structures.
- Studies by other agencies—none.
- Environmental, risk assessment shows:
 - no buildings near floodplain,
 - no sensitive floodplain values,
 - no FEMA involvement, and
 - convenient detours exist.
- Design criteria:
 - 50-year frequency for design, and
 - 100-year frequency for check.

Step 2. Determine hydrology.

USGS regression equations yield:

- $Q_{50} = 400 \text{ cfs}$
- $Q_{100} = 500 \text{ cfs}$

Step 3. Design downstream channel, cross section of channel (Slope = 0.05 ft/ft).

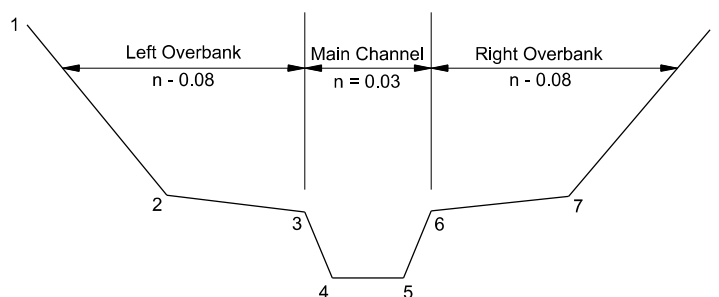

Point	Station, ft	Elevation, ft
1	12	180.0
2	22	175.0
3	32	174.5
4	34	172.5
5	39	172.5
6	41	174.5
7	51	175.0
8	61	180.0

The rating curve for the channel calculated by normal depth yields:

Q (cfs)	TW (ft)	V (fps)
100	1.4	11.1
200	2.1	13.7
300	2.5	16.0
400	2.8	17.5
500	3.1	18.8

Step 4. Summarize data on design form.

See Figure 9.6-F.

Step 5. Select design alternative.

Shape—box Size—7 ft × 6 ft (B × D)
 Material—concrete Entrance—beveled

Step 6. Select design discharge.

$$Q_d = Q_{50} = 400 \text{ cfs}$$

Step 7. Determine inlet control headwater depth (HW_i).

Use inlet control nomographs—Section 9.14, Figure 9.14-L (Chart 10B):

- a. $D = 6 \text{ ft}$
- b. $Q = Q_d/\text{number of barrels}$
 1. $Q = 400/1 = 400 \text{ cfs}$
 2. $Q/NB = 400/7 = 57$
- c. $HW/D = 1.33$ for $3/4$ in chamfer
 $HW/D = 1.27$ for 45° bevel
- d. $HW_i = (HW/D)D = (1.27)6 = 7.6 \text{ ft}$ (neglect the approach velocity).

Step 8. Determine outlet control headwater depth at inlet (HW_o).

- a. $TW = 2.8 \text{ ft}$ for $Q_{50} = 400 \text{ cfs}$ (from tailwater rating curve, step 3)
- b. $d_c = 4.7 \text{ ft}$ from Section 9-14, Figure 9.14-P (Chart 14B)
- c. $(d_c + D)/2 = (4.7 + 6)/2 = 5.4 \text{ ft}$
- d. $h_o =$ the larger of TW or $(d_c + D)/2$
 $h_o = (d_c + D)/2 = 5.4 \text{ ft}$
- e. $k_e = 0.2$ from Figure 9.14-B
- f. Determine (H) from Section 9.14, Figure 9.14-Q (Chart 15B):
 - k_e scale = 0.2
 - culvert length (L) = 300 ft
 $n = 0.012$ (same as on chart)
 - area = 42 ft^2
 - $H = 2.8 \text{ ft}$
- g. $HW_o = H + h_o - S_oL = 2.8 + 5.4 - (0.05)300 = -6.8 \text{ ft}$

Because HW_o is less than $1.2D$, the barrel will not flow full at the design discharge, which is the conservative assumption used for hand or nomograph solutions. The assumption is extremely conservative in this case because a negative HW_o indicates that the required HW is below the streambed. A computer solution shows that Flow Type 5 (see Figure 9.6-A) is present in the barrel at the design discharge.

Step 9. Determine controlling headwater (HW_c).

- a. $HW_c = HW_i = 7.6 \text{ ft} > HW_{oi} = -6.8 \text{ ft}$
- b. The culvert is in inlet control.

Step 10. Compute discharge over roadway (Q_o).

- a. Calculate depth above the roadway:

$$HW_{ov} = 196 - 187.5 = 8.5$$

$$HW_r = HW_c - HW_{ov} = 7.6 - 8.5 = -0.9 \text{ ft}$$

- b. If $HW_r \leq 0$, $Q_r = 0$

Step 11. Compute total discharge (Q_t).

$$Q_t = Q_d + Q_o = 400 \text{ cfs} + 0 = 400 \text{ cfs}$$

Step 12. Calculate outlet depth (d_n) and velocity (V_o).

Inlet Control:

- a. Calculate normal depth (d_n):

$$Q = (1.486/n)A R^{2/3} S^{1/2} = 400 \text{ cfs}$$

$$400 = (123.8)(7)(d_n)[7(d_n)/(7 + 2d_n)]^{2/3}(0.05)^{0.5}$$

$$14.4 = (7)(d_n)[7(d_n)/(7 + 2d_n)]^{2/3}$$

$$\text{try } d_n = 2.0 \text{ ft, } 16.5 > 14.4$$

$$\text{use } d_n = 1.8 \text{ ft, } 14.1 \approx 14.4$$

- b. $A = (1.8)7 = 12.6 \text{ ft}^2$

- c. $V_o = Q/A = 400/12.6 = 31.7 \text{ fps}$

Step 13. Review results.

Compare alternative design with constraints and assumptions. If any of the following are exceeded, repeat Steps 5 through 12:

- barrel has $(8.5 - 6) = 2.5$ ft of cover,
- $L = 300$ ft is OK, since inlet control,
- headwalls and wingwalls fit site,
- allowable headwater (8.5 ft) > 7.6 ft is OK, and
- overtopping flood frequency > 50-year.

Step 14. Plot performance curve.

Use Q_{100} for the upper limit. Steps 6 through 12 should be repeated for each discharge used to plot the performance curve. These computations are provided on the Culvert Design Form that follows this example (see Figure 9.8-A).

PROJECT: <u>Example Problem</u>		STATION: <u>9+00</u>		CULVERT DESIGN FORM														
		SHEET <u>1</u> OF <u>1</u>		DESIGNER / DATE: <u>plt</u> / <u>12/1/2011</u>														
				REVIEWER / DATE: <u>tn</u> / <u>12/1/2011</u>														
HYDROLOGICAL DATA			<p style="text-align: center;">Roadway Elevation: <u>196 (ft)</u> EL_{na}: <u>196 (ft)</u> EL_{sf}: <u>187.5 (ft)</u>, S_o: <u>0.05</u> Original Stream Bed EL: <u>187.5 (ft)</u> S = S_o - T/L_o S = <u>0.05 ft/ft</u> L_o = <u>300 ft</u></p>															
□ METHOD: <u>USGS</u> □ DRAINAGE AREA: _____ □ STREAM SLOPE: <u>.05 ft/ft</u> □ CHANNEL SHAPE: <u>irregular cross section</u> □ ROUTING: _____ □ OTHER: _____																		
DESIGN FLOWS/TAIWATER																		
R.I. (YEARS)	FLOW (cfs)	TW (ft)																
<u>50</u>	<u>400</u>	<u>2.8</u>																
<u>100</u>	<u>500</u>	<u>3.1</u>																
CULVERT DESCRIPTION:			HEADWATER CALCULATIONS															
MATERIAL - SHAPE - SIZE - ENTRANCE		Total Flow Q (cfs)	Flow Per Barrel Q/N (1)	INLET CONTROL		OUTLET CONTROL		Control Headwater Elevation	Outlet Velocity	Comments								
RCB - 7 ft x 6 ft - Bevel		400	57	HW/D (2)	HW _i (3)	T (4)	EL _{in} (5)	TW (6)	d _t (7)	d _t +D/2 (8)	h _o (9)	k _e (10)	H (11)	EL _{ho} (12)	195.1	32	195.1 < 196 ok	
		500	72	1.56	9.4	0	196.9	3.1	5.4	5.7	5.7	0.2	4.3	182.2	196.9	34	196 calc Q _c	
Performance Curve		100	14	0.46	2.8	0	190.3											
		200	29	0.78	4.7	0	192.2											
		300	43	1.01	6.1	0	193.6											
TECHNICAL FOOTNOTES:																		
(1) USE O/NB FOR BOX CULVERTS			(4) EL _{in} = HW _i + EL (INVERT OF INLET CONTROL SECTION)			(6) h _o = TW or (d _t + D) / 2 (WHICHEVER IS GREATER)												
(2) HW / D = HW / D OR HW _i / D FROM DESIGN CHARTS			(5) TW BASED ON DOWN STREAM CONTROL OR FLOW DEPTH IN CHANNEL			(7) H = [1 + k _e + (K _v n ² L) / R ^{1.33}] v ² / 2g WHERE Ku = 19.63 (29 IN ENGLISH UNITS)												
(3) T = HW - (EL _{in} - EL _o) T IS ZERO FOR CULVERTS ON GRADE			(8) EL _{ho} = EL _o + H + h _o															
SUBSCRIPT DEFINITIONS:			COMMENTS / DISCUSSION:			CULVERT BARREL SELECTED:												
a. APPROXIMATE f. CULVERT FACE ha. ALLOWABLE HEADWATER hi. HEADWATER IN INLET CONTROL ho. HEADWATER IN OUTLET CONTROL i. INLET CONTROL SECTION o. OUTLET sf. STREAMBED AT CULVERT FACE tw. TAILWATER			Assume 500 ft ³ /s in culvert (196.9 - 196) = 0.9 ft Q _i = C _D L (HW _i) ^{1.5} = 3.03(200)(0.9) ^{1.5} = 520 ft ³ /s Q _T = 500 + 520 = 1020 ft ³ /s			SIZE: <u>7 ft x 6 ft</u> SHAPE: <u>RCB</u> MATERIAL: _____ n <u>0.012</u> ENTRANCE: <u>Bevel</u>												

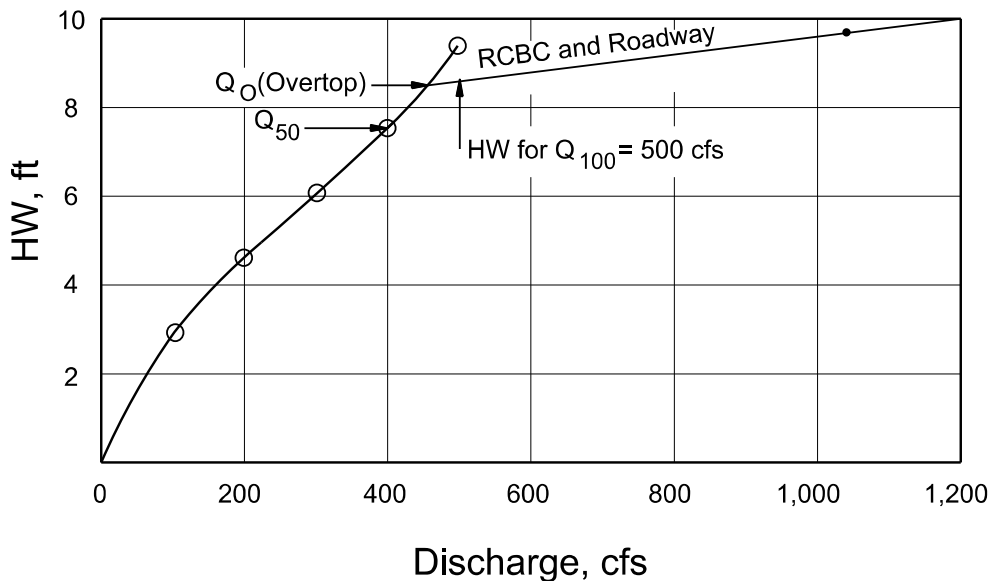

Figure 9.8-A — CULVERT DESIGN FORM AND PERFORMANCE CURVE FOR DESIGN EXAMPLE

Step 15. Special considerations.

Consider the following options:

- Tapered Inlets. Culvert is in inlet control and has limited available headwater.
- Flood Routing. Because a small upstream headwater pool exists, flood routing is not feasible.
- Broken-Back Culvert. No break in slope is needed.
- Energy Dissipation. Because $V_o = 31.7 \text{ fps} > 18.0 \text{ fps}$ in the downstream channel, review options in Chapter 11 “Energy Dissipators.”
- Debris Control. The site has no sediment or other debris problems.
- Fish Passage. The stream is not a fishery and does not have other aquatic organism concerns.

Step 16. Documentation.

Report prepared and background filed.

9.8.1 HY-8 Solution

The hand solution shown above can be duplicated using HY-8:

- Enter Site Data shown in Step 1. For tailwater, enter irregular channel in Step 3.
- Enter Culvert Type and Size from Step 5, select straight. For Inlet Edge, select bevel edge 1V:1H. For Inlet Depression, select No.
- Analyze Crossing brings up Crossing Summary Table that shows 30.8 cfs overtopping at 500 cfs.
- Select Culvert Summary Table, which shows that at 400 cfs inlet control governs: $HW_i = 7.49 \text{ ft}$ and $El_{hi} = 194.89 \text{ ft} \approx 195.1 \text{ ft}$ of the nomograph solution for bevel edges.

9.9 DOCUMENTATION

A Hydraulic Design Report should be prepared for major and unusual culverts.

9.9.1 Draft Hydraulic Design Report

In addition to the items discussed in Chapter 6 “Documentation,” the report should include the following, as appropriate:

1. Site-Specific Hydraulic Performance Criteria (see Chapter 9 “Culverts”)
2. Risk Assessment
 - Floodplain land use
 - Environmentally sensitive areas (e.g., fisheries, wetlands)
3. Stream Stability Assessment (see Chapter 16 “Stream Stability”)
 - Level I qualitative analysis
 - Geomorphic factors and hydraulic factors that affect stream stability
 - Identification of existing bed or bank instability
4. Hydrologic Computations
 - Discharges for specified frequencies
 - Discharge and frequency for historical flood that complements the high-water marks used for calibration
5. Hydraulic Computations
 - Computational method
 - Computer model selection (see Chapter 16 “Hydraulic Software”)
 - Hydraulic performance for existing conditions
 - Hydraulic performance of proposed designs
 - Scour computations, if appropriate

9.9.2 Final Hydraulic Design Report

In addition to the items already included in the Draft Hydraulic Design Report, the Final Hydraulic Design Report should include the following, as appropriate:

- Risk analysis documentation, (if applicable).
- Countermeasure design details (see Chapter 8 “Channels”).
- Scour computations, countermeasures, monitoring plan or instrumentation, if applicable.

An example of the Final Hydraulics Design Report is as shown in Appendix 6.A, Chapter 6 “Documentation.”

9.10 STORAGE ROUTING

9.10.1 Introduction

Significant storage capacity behind a highway embankment can attenuate a flood hydrograph. Because of the reduction of the peak discharge associated with this attenuation, the required capacity of the culvert, and its size, can be reduced. This section outlines how to complete hydrologic routing. Detailed information on routing is provided in HEC-22 (12) and in HDS-5 (2). While the calculation is not difficult and is readily completed with the FHWA Hydraulic Toolbox, most culvert designs do not consider attenuation upstream of the embankment, but rather consider it part of the safety factor in the design (see HDS-5, Chapter 5 (2)).

9.10.2 Design Procedure

Flood routing through a culvert is easily accomplished with the FHWA Hydraulic Toolbox or other software (see Chapter 16 “Hydraulic Software”). The design procedure is the same as for reservoir routing (see Chapter 12 “Storage Facilities”):

- The site data including storage data and roadway geometry are obtained (see Chapter 5 “Data Collection”).
- The hydrology analysis should include estimating a hydrograph (see Chapter 7 “Hydrology”).
- A trial culvert size is estimated and the hydrograph is routed.

Before attempting to design a culvert to take advantage of storage, the hydraulics designer should review the culvert storage routing design process included in HDS-5, Chapter 5 (2).

9.11 TAPERED INLETS

9.11.1 General

A tapered inlet is a flared culvert inlet with an enlarged face section and a hydraulically efficient throat section. A tapered inlet may have a throat depression incorporated into the inlet structure or located upstream of the inlet. The depression is used to exert more head on the throat section for a given headwater elevation. Therefore, tapered inlets improve culvert performance by providing a more efficient control section (the throat). Tapered inlets are not recommended for use on culverts flowing in outlet control because the simple beveled edge is of equal benefit.

Design criteria and methods have been developed for two basic tapered inlet designs:

- the side-tapered inlet, and
- the slope-tapered inlet.

Tapered inlet design charts are available for rectangular-box culverts and circular-pipe culverts.

9.11.2 Side-Tapered Inlets

The side-tapered inlet has an enlarged face section with the transition to the culvert barrel accomplished by tapering the side walls (Figure 9.11-A). The face section is approximately the same height as the barrel height, and the inlet floor is an extension of the barrel floor. The inlet roof may slope upward slightly, provided that the face height does not exceed the barrel height by more than 10% (1.1D). The intersection of the tapered sidewalls and the barrel is defined as the throat section.

There are two possible control sections—the face and the throat. HW_f , shown in Figure 9.11-A, is the headwater depth measured from the face section invert, and HW_t is the headwater depth measured from the throat section invert. The throat of a side-tapered inlet is a very efficient control section. The flow contraction is nearly eliminated at the throat. In addition, the throat is always slightly lower than the face so that more head is exerted on the throat for a given headwater elevation.

The beneficial effect of depressing the throat section below the streambed can be increased by installing a depression upstream of the side-tapered inlet. Figure 9.11-B depicts a side-tapered inlet with the depression contained between wingwalls. For this type of depression, the floor of the barrel should extend upstream from the face a minimum distance of $D/2$ before sloping upward more steeply. The length of the resultant upstream crest where the slope of the depression meets the streambed should be checked to ensure that the crest will not control the flow at the design flow and headwater. If the crest length is too short, the crest may act as a weir-control section; the barrel is defined as the throat section.

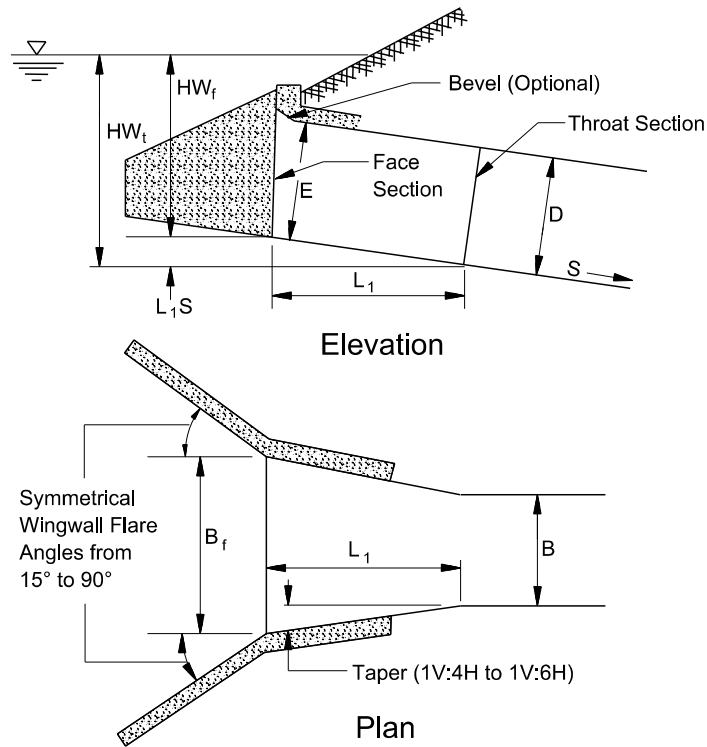

Figure 9.11-A — SIDE-TAPERED INLET

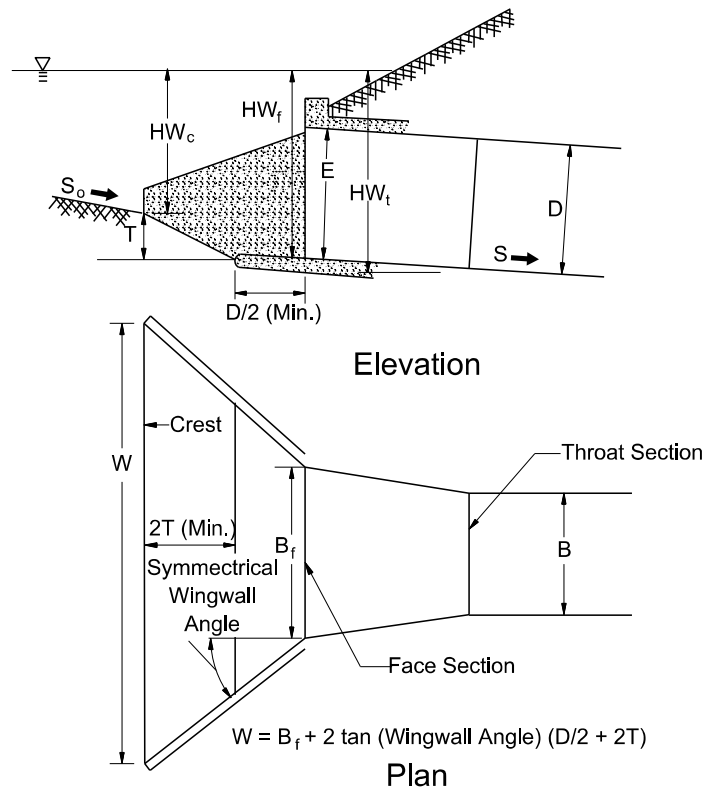

Figure 9.11-B — SIDE-TAPERED INLET WITH UPSTREAM DEPRESSION CONTAINED BETWEEN WINGWALLS

9.11.3 Slope-Tapered Inlets

The slope-tapered inlet, like the side-tapered inlet, has an enlarged face section with tapered sidewalls meeting the culvert barrel walls at the throat section (Figure 9.11-C). In addition, a vertical depression is incorporated into the inlet between the face and throat sections. This depression concentrates more head on the throat section. At the location where the steeper slope of the inlet intersects the flatter slope of the barrel, a third section, designated the bend section, is formed.

A slope-tapered inlet has three possible control sections—the face, the bend and the throat. Of these, only the dimensions of the face and the throat section are determined by the design procedures of HDS-5 (2). The size of the bend section is established by locating it a minimum distance upstream from the throat so that it will not control the flow.

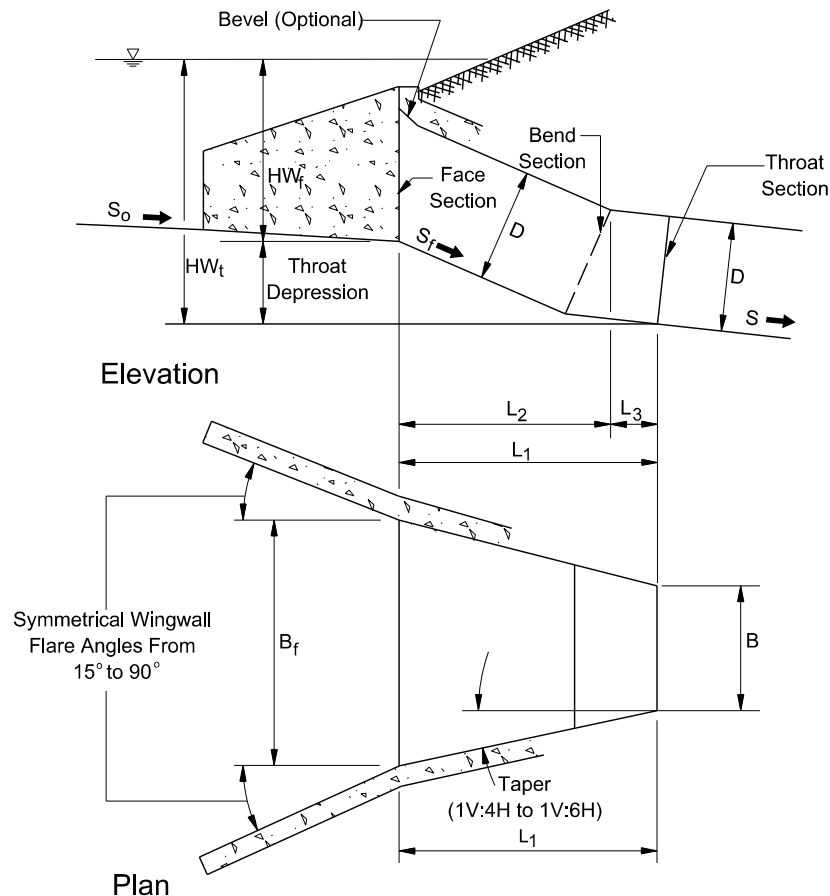

Figure 9.11-C — SLOPE-TAPERED INLET WITH VERTICAL FACE

The slope-tapered inlet combines an efficient throat section with additional head on the throat. The face section does not benefit from the depression between the face and throat; therefore, the face sections of these inlets are larger than the face sections of equivalent depressed side-tapered inlets. The required face size can be reduced by the use of bevels or other favorable edge configurations. The vertical face slope-tapered inlet design is shown in Figure 9.11-C.

The slope-tapered inlet is the most complex inlet improvement recommended in this chapter. Construction difficulties are inherent, but the benefits in increased performance can be significant. With proper design, a slope-tapered inlet passes more flow at a given headwater elevation than any other configuration. Slope-tapered inlets can be applied to both box culverts and circular-pipe culverts. For the latter application, a square-to-round transition is normally used to connect the rectangular, slope-tapered inlet to the circular pipe.

9.11.4 Hydraulic Design

9.11.4.1 Inlet Control

Tapered inlets have several possible control sections including the face, the bend (for slope-tapered inlets) and the throat. In addition, a depressed side-tapered inlet has a possible control section at the crest upstream of the depression. Each of these inlet control sections has an individual performance curve. The headwater depth for each control section is referenced to the invert of the section. One method of determining the overall inlet control performance curve is to calculate performance curves for each potential control section, and then select the segment of each curve, which defines the minimum overall culvert performance (see Figure 9.11-D).

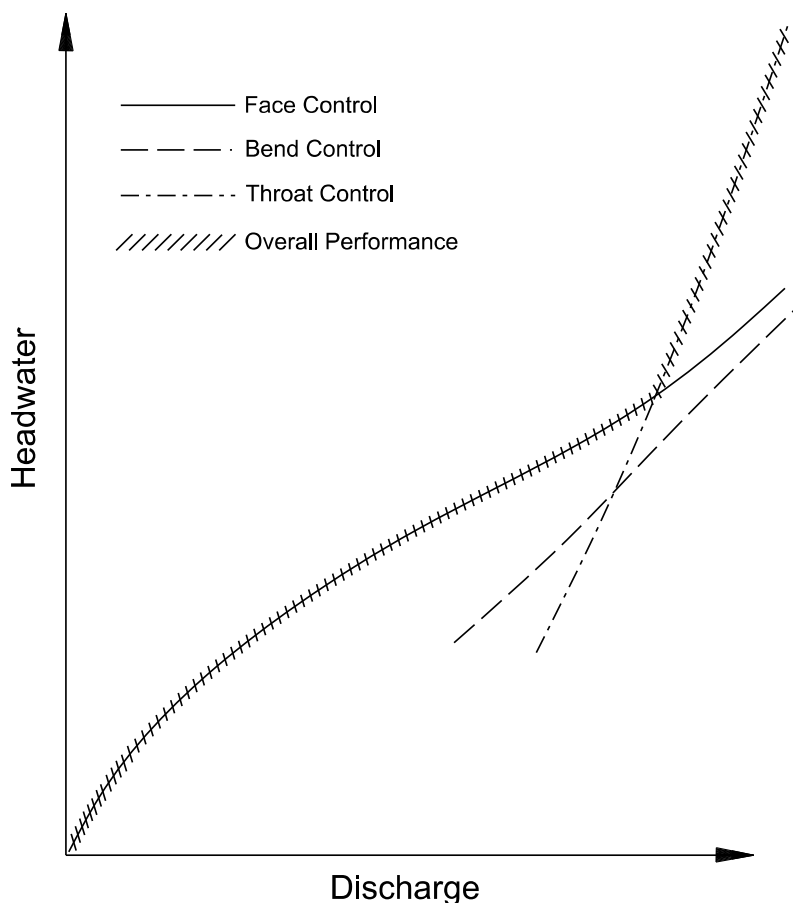

Figure 9.11-D — INLET CONTROL PERFORMANCE CURVES (Schematic)

9.11.4.2 Side-Tapered Inlet

The side-tapered inlet throat should be designed to be the primary control section for the design range of flows and headwaters. Because the throat is only slightly lower than the face, it is likely that the face section will function as a weir or an orifice with downstream submergence within the design range. At lower flow rates and headwaters, the face will usually control the flow.

9.11.4.3 Slope-Tapered Inlet

The slope-tapered inlet throat can be the primary control section with the face section submerged or unsubmerged. If the face is submerged, the face acts as an orifice with downstream submergence. If the face is unsubmerged, the face acts as a weir, with the flow plunging into the pool formed between the face and the throat. As previously noted, the bend section will not act as the control section if the dimensional criteria of HDS-5 (2) are followed. However, the bend will contribute to the inlet losses that are included in the inlet loss coefficient, k_e .

9.11.4.4 Outlet Control

When a culvert with a tapered inlet performs in outlet control, the hydraulics are the same as described in Section 9.2 for all culverts. The tapered inlet entrance loss coefficient (k_e) is 0.2 for both side-tapered and slope-tapered inlets. This loss coefficient includes contraction and expansion losses at the face, increased friction losses between the face and the throat and the minor expansion and contraction losses at the throat.

9.11.5 Design Methods

Tapered inlet design begins with the selection of the culvert barrel size, shape and material. The design procedure is similar to designing a culvert with other control sections (face and throat). The result will be one or more culvert designs, with and without tapered inlets, all of which meet the site design criteria. The hydraulics designer must select the best design for the site under consideration.

In the design of tapered inlets, the goal is to maintain control at the efficient throat section in the design range of headwater and discharge. This is because the throat section has the same geometry as the barrel, and the barrel is the most costly part of the culvert. The inlet face is then sized large enough to pass the design flow without acting as a control section in the design discharge range. Some slight oversizing of the face is beneficial because the cost of constructing the tapered inlet is usually minor compared with the cost of the barrel.

9.11.6 Performance Curves

Performance curves illustrate the operation of a culvert with a tapered inlet. Each potential control section (face, throat and outlet) has a performance curve, based on the assumption that the particular section controls the flow. Calculating and plotting the various performance curves results in a graph similar to Figure 9.11-E, containing the face control, throat control and outlet control curves. The overall culvert performance curve is represented by the hatched line. In the range of lower discharges, face control governs; in the intermediate range, throat control governs and, in the higher discharge range, outlet control governs. The crest and bend performance curves are not calculated because they do not govern in the design range.

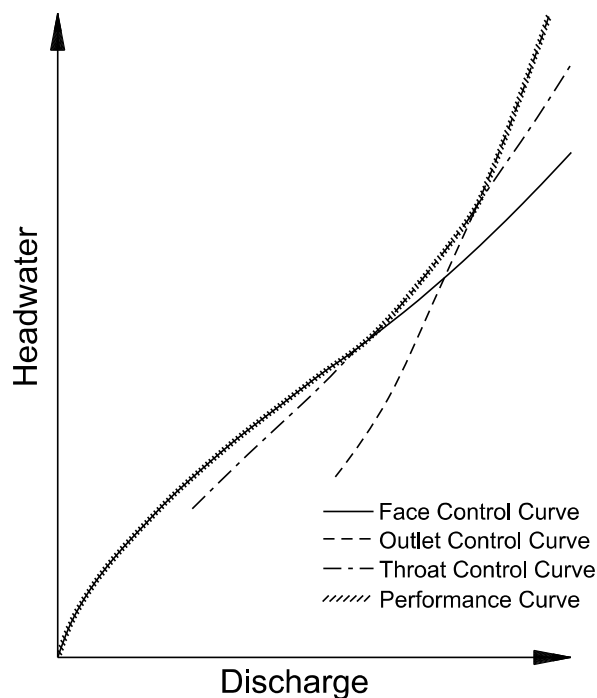

Figure 9.11-E — CULVERT PERFORMANCE CURVE (Schematic)

9.12 BROKEN-BACK CULVERTS

9.12.1 Introduction

An alternative to installing a steeply sloped culvert is to break the slope into a steeper portion near the inlet followed by a horizontal runout section. This configuration is referred to as a broken-back culvert. Broken-back culverts can be considered an internal (integrated) energy dissipater if designed so that a hydraulic jump occurs in the runout section to dissipate energy (see HEC-14 (10)).

9.12.2 Guidelines

One potential mechanism for creating a hydraulic jump is the broken-back configuration. Two types are depicted in Figure 9.12-A and Figure 9.12-B. When used appropriately, a broken-back culvert configuration can influence and contain a hydraulic jump. However, there must be sufficient tailwater, and there should be sufficient friction and length in Unit 3 (see Figure 9.12-A and Figure 9.12-B) of the culvert. In ordinary circumstances for broken-back culverts, the hydraulics designer should employ one or more devices, such as roughness baffles, to create a tailwater that is high enough to force a hydraulic jump.

9.12.3 Design Procedure

The design of a broken-back culvert is not difficult, but provisions must be made so that the primary intent of reducing velocity at the outlet is realized. The hydraulics of circular and rectangular culverts can be determined using the FHWA HY-8 software or the Broken-back Culvert Analysis Program (BCAP) software from the Nebraska Department of Roads. The design of associated energy dissipators is contained in HEC-14, Chapter 7 (10).

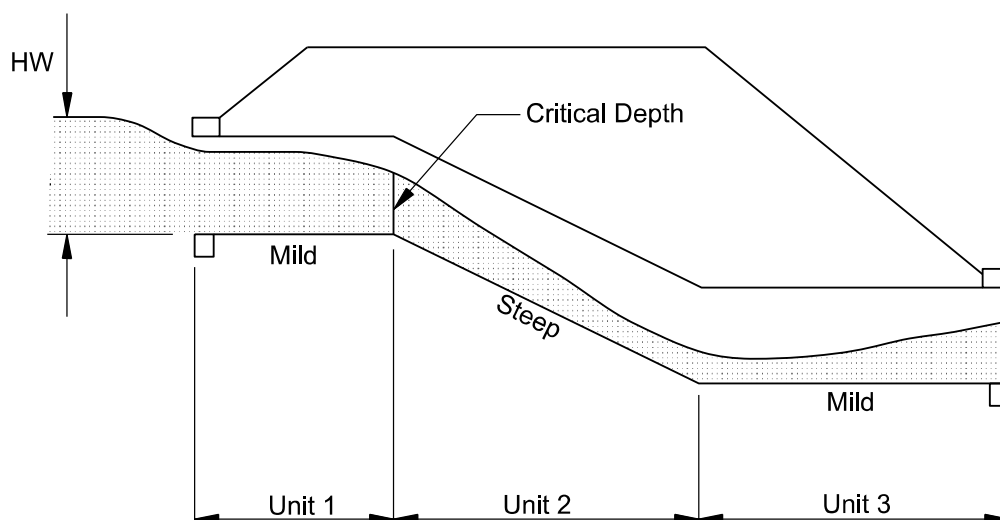

Figure 9.12-A — THREE-UNIT BROKEN-BACK CULVERT

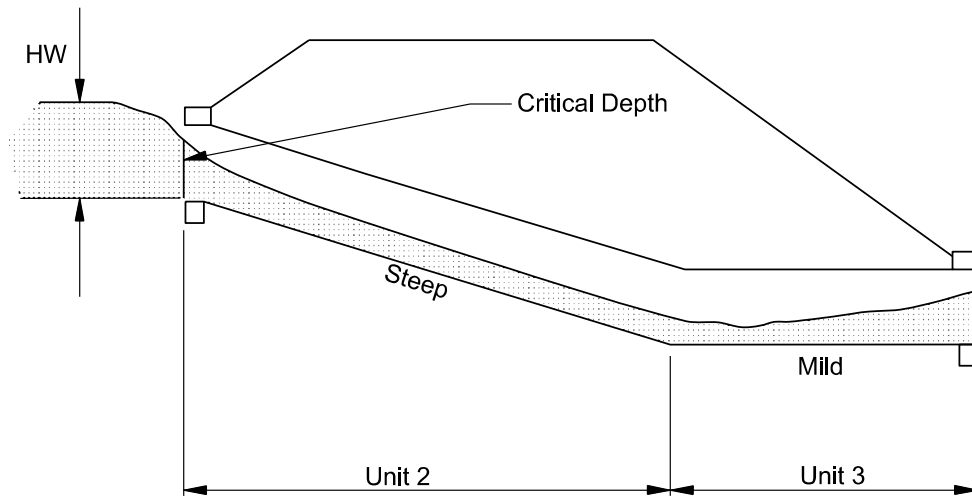
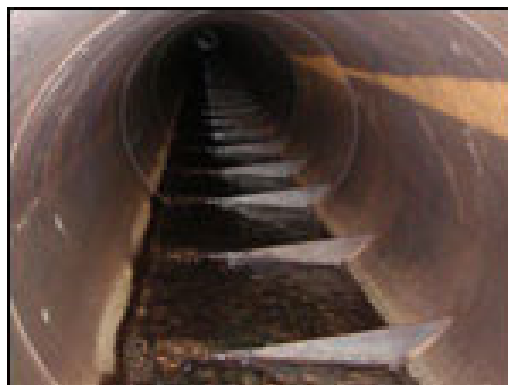

Figure 9.12-B — TWO-UNIT BROKEN-BACK CULVERT

9.13 AQUATIC ORGANISM PASSAGE

Simulating the natural stream bottom conditions in a culvert is the most desirable design option to accommodate aquatic organisms or to provide for the transport of large bed material. Open bottom culverts, such as arches, have obvious advantages if adequate foundation support exists for the culvert. Oversized embedded culverts have the advantage of a natural bottom while overcoming the problem of poor foundation material. The process of sizing an embedded culvert is provided in HEC-26 (4).

Baffles can also be constructed in the bottom of culverts to facilitate fish passage (Figures 9.13-A). The hydraulic design of culverts with baffles is accomplished by modifying the friction resistance of the barrel in outlet control to account for the resistance of the bed material or the resistance imposed by the baffles if no bed material is retained. HEC-14, Section 7.2 Increased Resistance (10) provides equations and procedures for estimating the hydraulic loss due to regularly spaced, horizontal baffles. A pair of horizontal baffles that are angled either upstream or downstream should be treated as a single perpendicular baffle when applying the equations and slots should be ignored. The highest composite n value is then used in the outlet control calculations. The increased resistance equations are also available in HY-8 in the energy dissipator option. For inlet control, the reduced area of the entrance due to the baffles is used.



Source: HDS-5 (2)

Figure 9.13-A — EMBEDDED CULVERT WITH BAFFLES

9.14 DESIGN AIDS

This section presents several tables, figures and forms required for the hydraulic design of culverts. These include:

1. Manning's n values that have been determined in the laboratory are provided in Figure 9.14-A with the recommended design n value. Culvert materials are either treated as smooth or a corrugated. In this way, alternative materials can be substituted for a given structure.
2. Entrance loss coefficients (k_e) are provided in Figure 9.14-B.
3. The following culvert nomographs for circular and rectangular shapes are included; see HDS-5 (2) for other culvert nomographs:
 - Figure 9.14-C Headwater Depth for Concrete Pipe Culverts with Inlet Control,
 - Figure 9.14-D Headwater Depth for C. M. Pipe Culverts with Inlet Control,
 - Figure 9.14-E Headwater Depth for Circular Pipe Culverts with Beveled Ring Inlet Control,
 - Figure 9.14-F Critical Depth (Circular Pipe),
 - Figure 9.14-G Head for Concrete Pipe Culverts Flowing Full ($n = 0.012$),
 - Figure 9.14-H Head for Standard C. M. Pipe Culverts Flowing Full ($n = 0.024$),
 - Figure 9.14-I Head for Structural Plate Corrugated Metal Pipe Culverts Flowing Full ($n = 0.0328$ to 0.0302),
 - Figure 9.14-J Headwater Depth for Box Culverts with Inlet Control,
 - Figure 9.14-K Headwater Depth for Inlet Control, Rectangular Box Culverts, Flared Wingwalls 18° to 33.7° and 45° with Beveled Edge at Top of Inlet,
 - Figure 9.14-L Headwater Depth for Inlet Control, Rectangular Box Culverts, 90° Headwall, Chamfered or Beveled Inlet Edges,
 - Figure 9.14-M Headwater Depth for Inlet Control, Single Barrel Box Culverts, Skewed Headwalls, Chamfered or Beveled Inlet Edges,
 - Figure 9.14-N Headwater Depth for Inlet Control, Rectangular Box Culverts, Flared Wingwalls, Normal and Skewed Inlet Edges, $\frac{3}{4}$ " Chamfer at Top of Opening,
 - Figure 9.14-O Headwater Depth for Inlet Control, Rectangular Box Culverts, Offset Flared Wingwalls and Beveled Edge at Top of Inlet,

- Figure 9.14-P Critical Depth (Rectangular Section),
 - Figure 9.14-Q Head for Concrete Box Culverts Flowing Full (n = 0.012), and
 - Figure 9.14-R Discharge Coefficients for Roadway Overtopping.
4. The following design forms are presented for hand calculations for the hydraulic design of culverts:
- Figure 9.14-S Culvert Design Form, which is the standard form used for culverts. The procedure in Section 11.3 is based on this form, and
 - Figure 9.14-T Side/Slope Tapered Design Form.

Type of Conduit	Wall Description	Manning's n Laboratory ¹	Design Value
Concrete Pipe	Smooth	0.010-0.011	0.012
Concrete Boxes	Smooth	0.012-0.015	0.012
Spiral Rib Metal Pipe	Smooth walls	0.012-0.013	0.012
Corrugated Metal Pipe, Pipe-Arch and Box	2 $\frac{2}{3}$ in \times $\frac{1}{2}$ in Annular	0.022-0.027	0.024
	2 $\frac{2}{3}$ in \times $\frac{1}{2}$ in Helical	0.011-0.023	0.024
	6 in \times 1 in Helical	0.022-0.025	0.024
	5 in \times 1 in	0.025-0.026	0.024
	3 in \times 1 in	0.027-0.028	0.024
	6 in \times 2 in Structural Plate	0.033-0.035	0.035
	9 in \times 2 $\frac{1}{2}$ in Structural Plate	0.033-0.037	0.035
Corrugated Polyethylene	Smooth	0.009-0.015	0.012
Corrugated Polyethylene	Corrugated	0.018-0.025	0.024
Polyvinyl Chloride (PVC)	Smooth	0.009-0.011	0.012

Notes:

1. Source: HDS-5 (2)

Figure 9.14-A — MANNING'S n VALUES FOR CULVERTS

$$H_e = k_e \left[\frac{v^2}{2g} \right]$$

Type of Structure and Design of Entrance	Coefficient, k_e
Pipe, Concrete	
Mitered to conform to fill slope	0.7
End section conforming to fill slope ¹	0.5
Projecting from fill, sq. cut end	0.5
Headwall or headwall and wingwalls	
Square-edge	0.5
Rounded (radius = 1/12D).....	0.2
Socket end of pipe (groove-end).....	0.2
Projecting from fill, socket end (groove-end).....	0.2
Beveled edges, 33.7° or 45° bevels	0.2
Side- or slope-tapered inlet	0.2
Pipe or Pipe-Arch, Corrugated Metal	
Projecting from fill (no headwall)	0.9
Mitered to conform to fill slope, paved or unpaved slope.....	0.7
Headwall or headwall and wingwalls square-edge	0.5
End section conforming to fill slope ¹	0.5
Beveled edges, 33.7° or 45° bevels	0.2
Side- or slope-tapered inlet	0.2
Box, Reinforced Concrete	
Wingwalls parallel (extension of sides)	
Square-edged at crown.....	0.7
Wingwalls at 10° to 25° or 30° to 75° to barrel	
Square-edged at crown.....	0.5
Headwall parallel to embankment (no wingwalls)	
Square-edged on 3 edges.....	0.5
Rounded on 3 edges to radius of 1/12 barrel dimension or beveled edges on 3 sides.....	0.2
Wingwalls at 30° to 75° to barrel	
Crown edge rounded to radius of 1/12 barrel dimension or beveled top edge	0.2
Side- or slope-tapered inlet	0.2

Source: HDS-5 (2)

Notes:

1. "End section conforming to fill slope," made of either metal or concrete, are the sections commonly available from manufacturers. From limited hydraulics tests, they are equivalent in operation to a headwall in both inlet and outlet control. Some end sections, incorporating a closed taper in their design, have a superior hydraulics performance. These latter sections can be designed using the information given for the beveled inlet.

Figure 9.14-B — ENTRANCE LOSS COEFFICIENTS (Outlet Control, Full or Partly Full)

CHART 1B

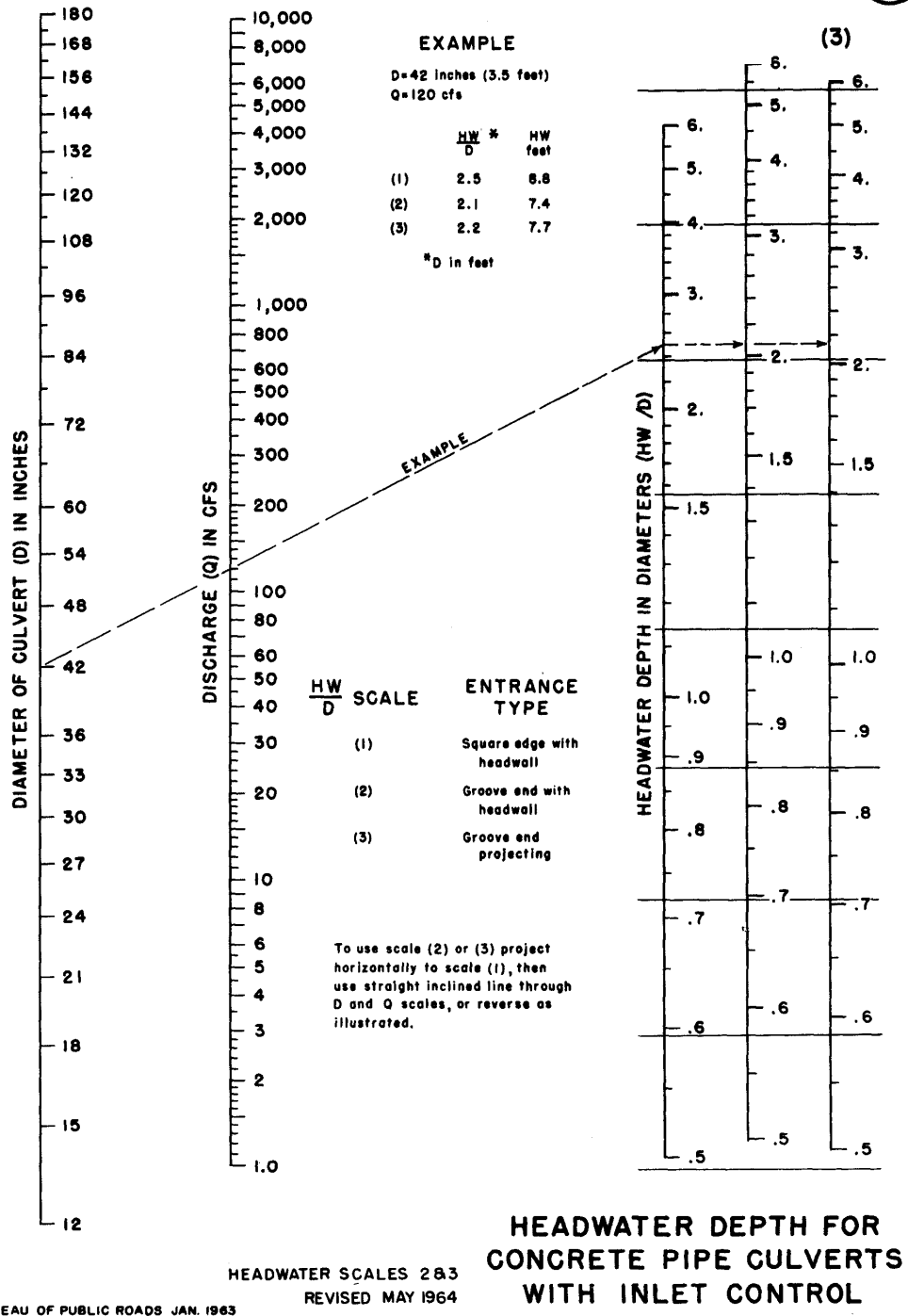
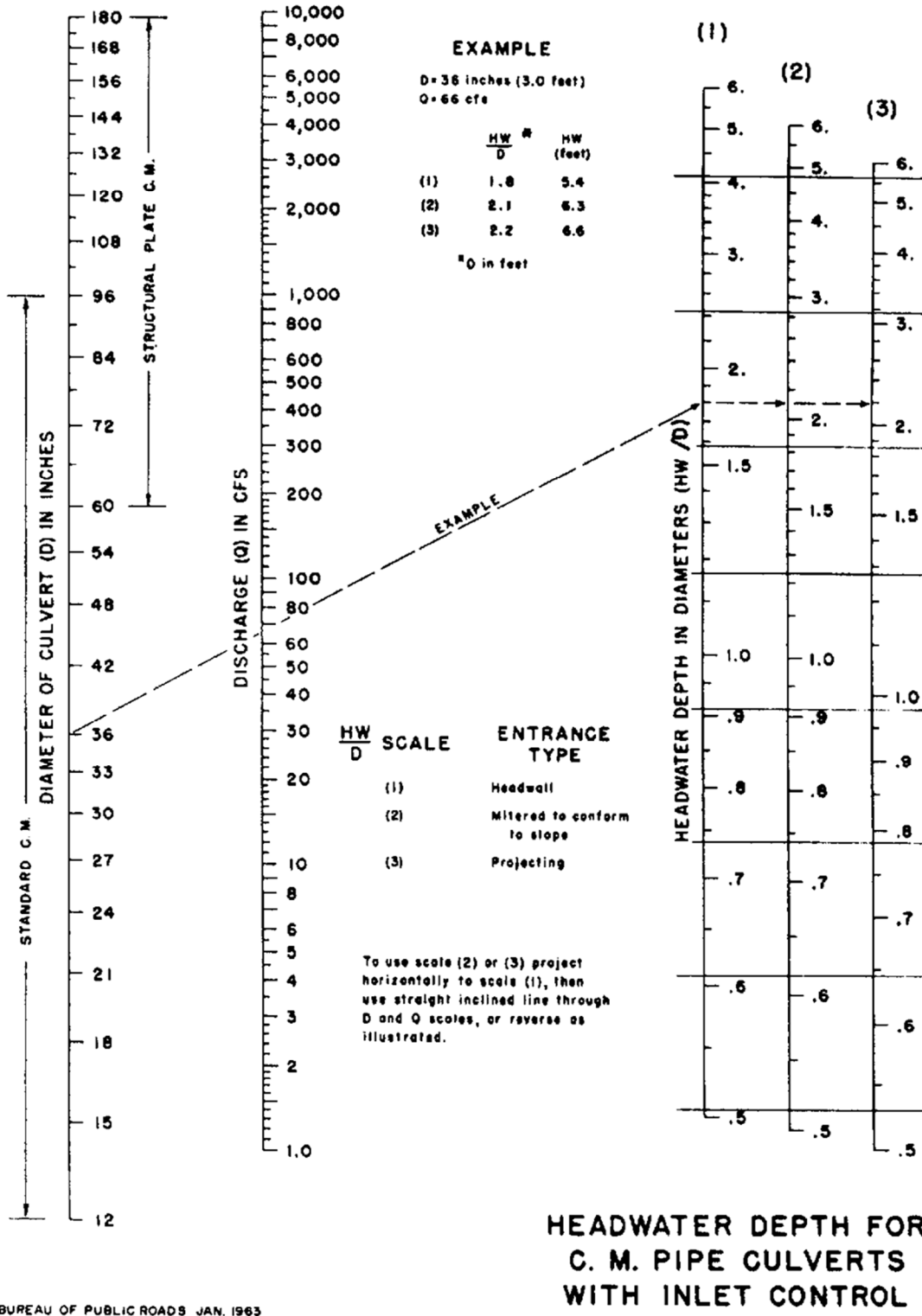

Figure 9.14-C — HEADWATER DEPTH FOR CONCRETE PIPE CULVERTS WITH INLET CONTROL

CHART 2B



BUREAU OF PUBLIC ROADS JAN. 1963

Figure 9.14-D — HEADWATER DEPTH FOR C. M. PIPE CULVERTS WITH INLET CONTROL

CHART 3B

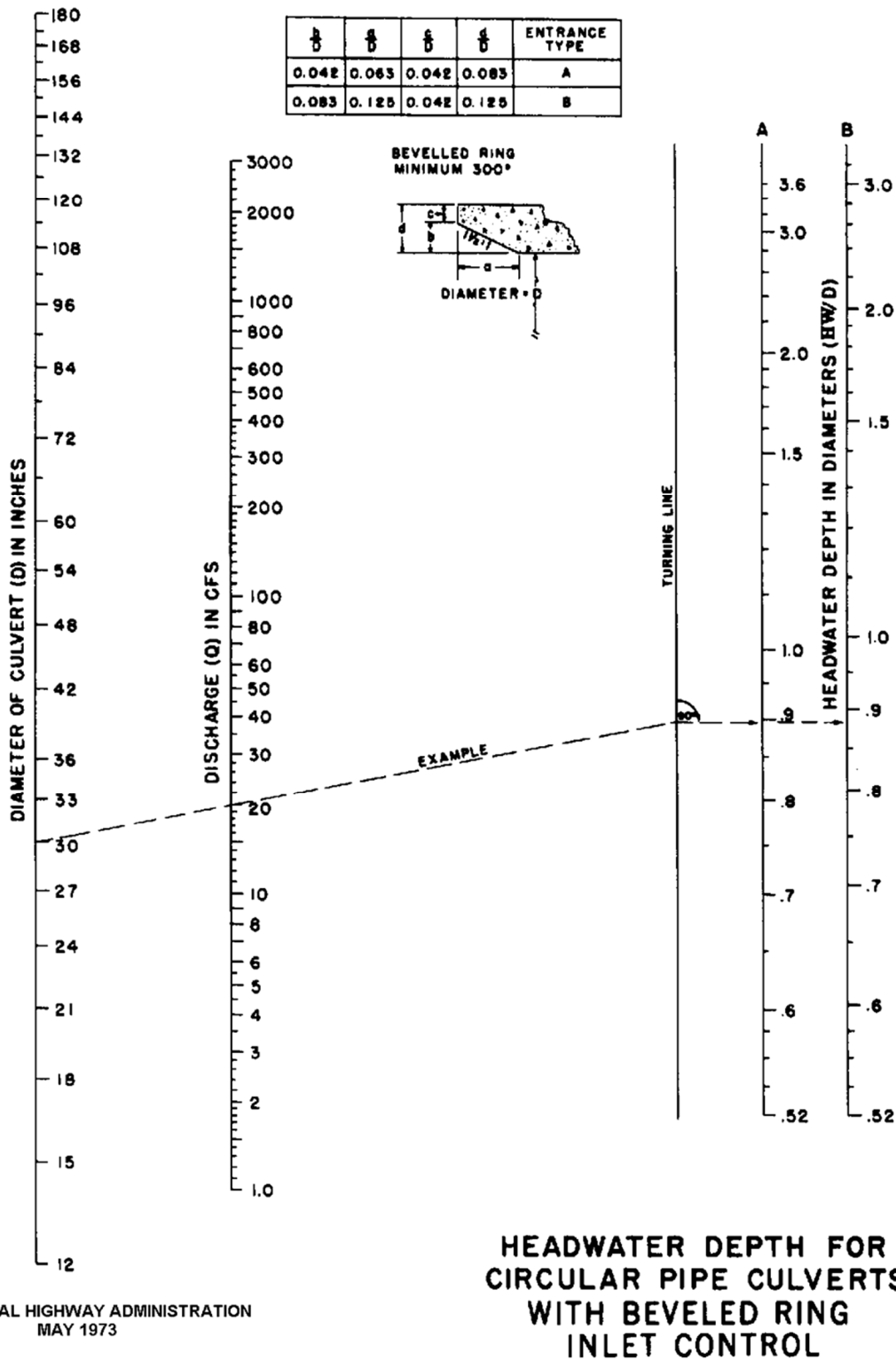
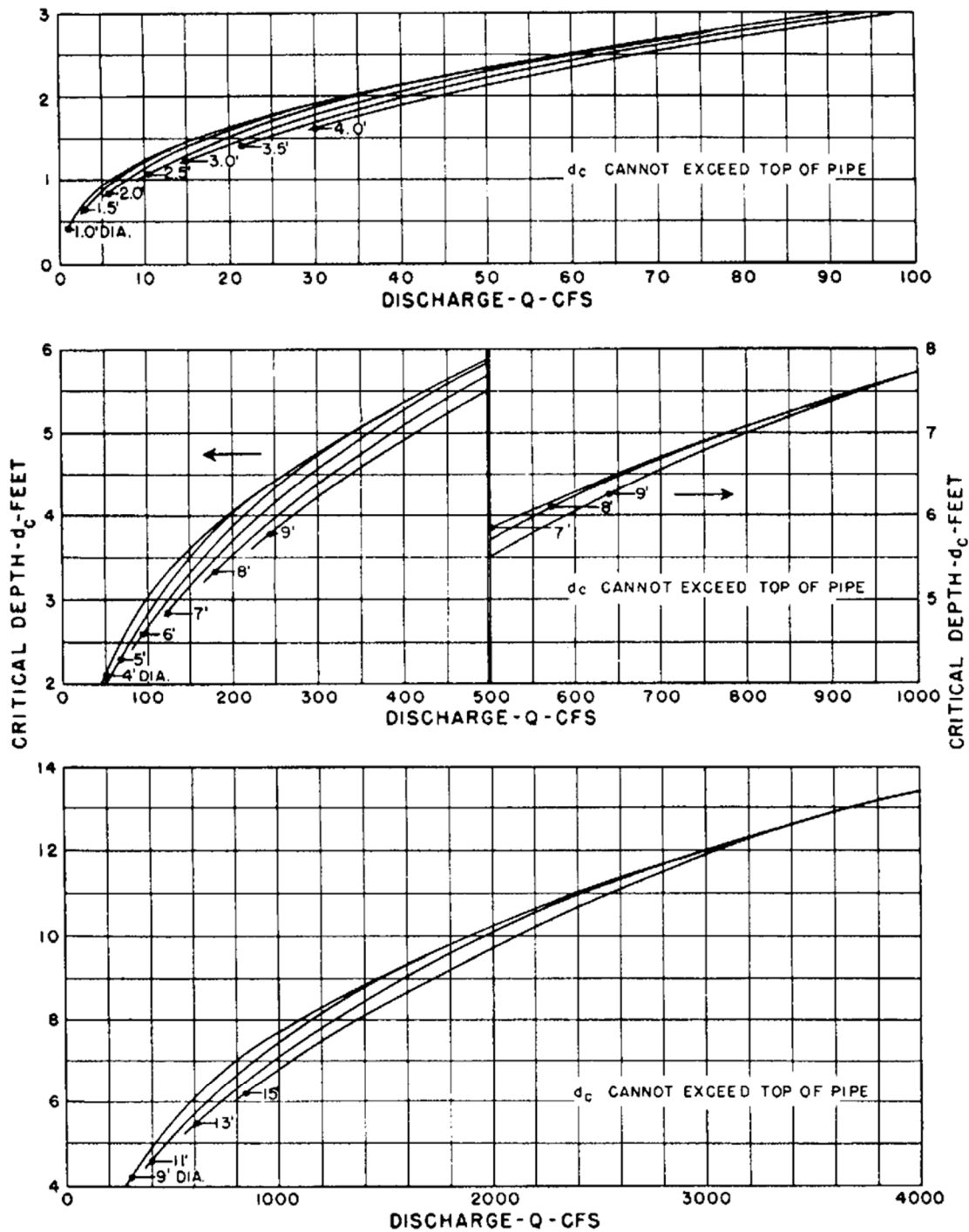

Figure 9.14-E — HEADWATER DEPTH FOR CIRCULAR PIPE CULVERTS WITH BEVELLED RING INLET CONTROL

CHART 4B



BUREAU OF PUBLIC ROADS
JAN. 1964

CRITICAL DEPTH
CIRCULAR PIPE

Figure 9.14-F — CRITICAL DEPTH (Circular Pipe)

CHART 5B

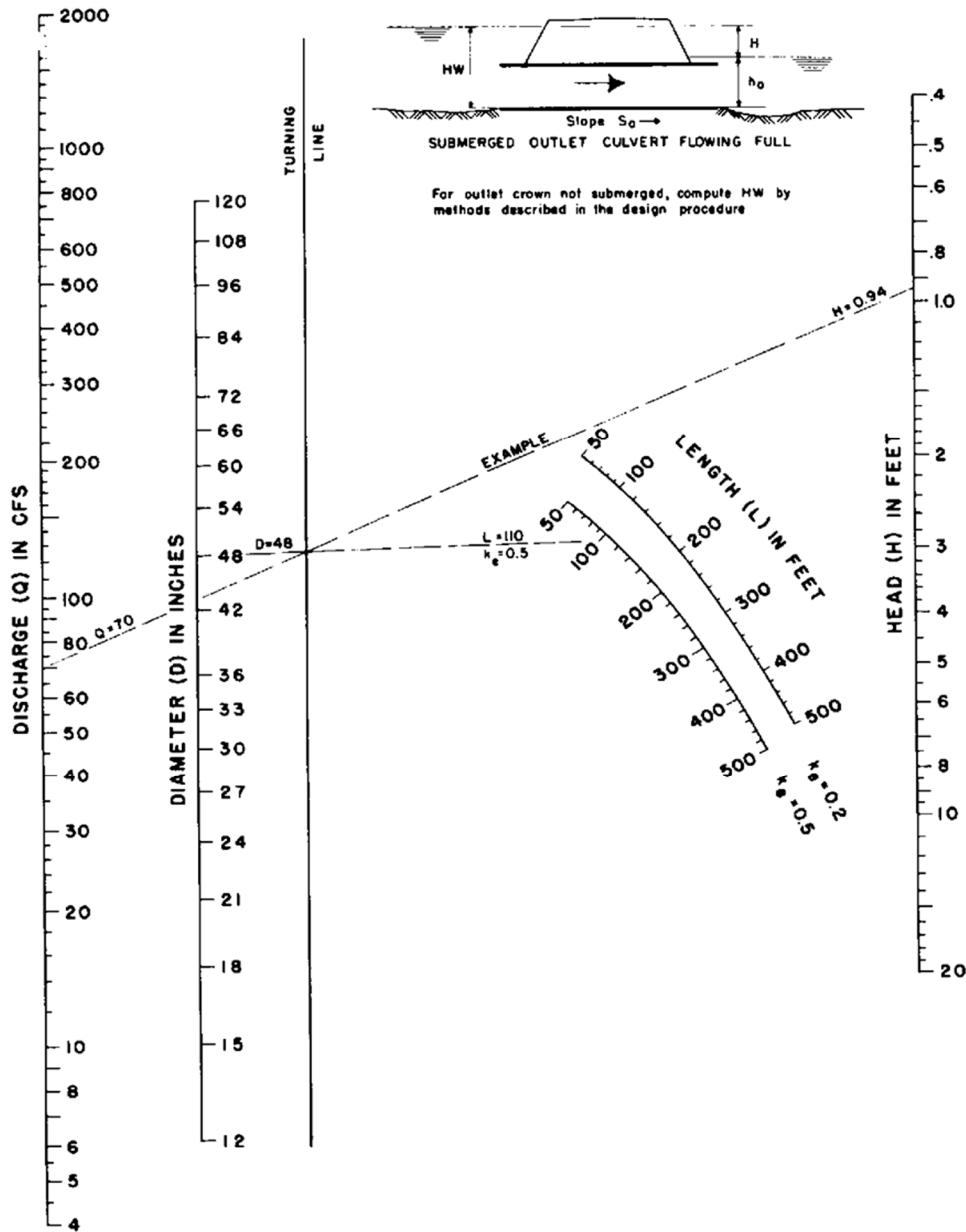

**HEAD FOR
CONCRETE PIPE CULVERTS
FLOWING FULL
 $n = 0.012$**

BUREAU OF PUBLIC ROADS JAN. 1963

Figure 9.14-G — HEAD FOR CONCRETE PIPE CULVERTS FLOWING FULL ($n = 0.012$)

CHART 6B

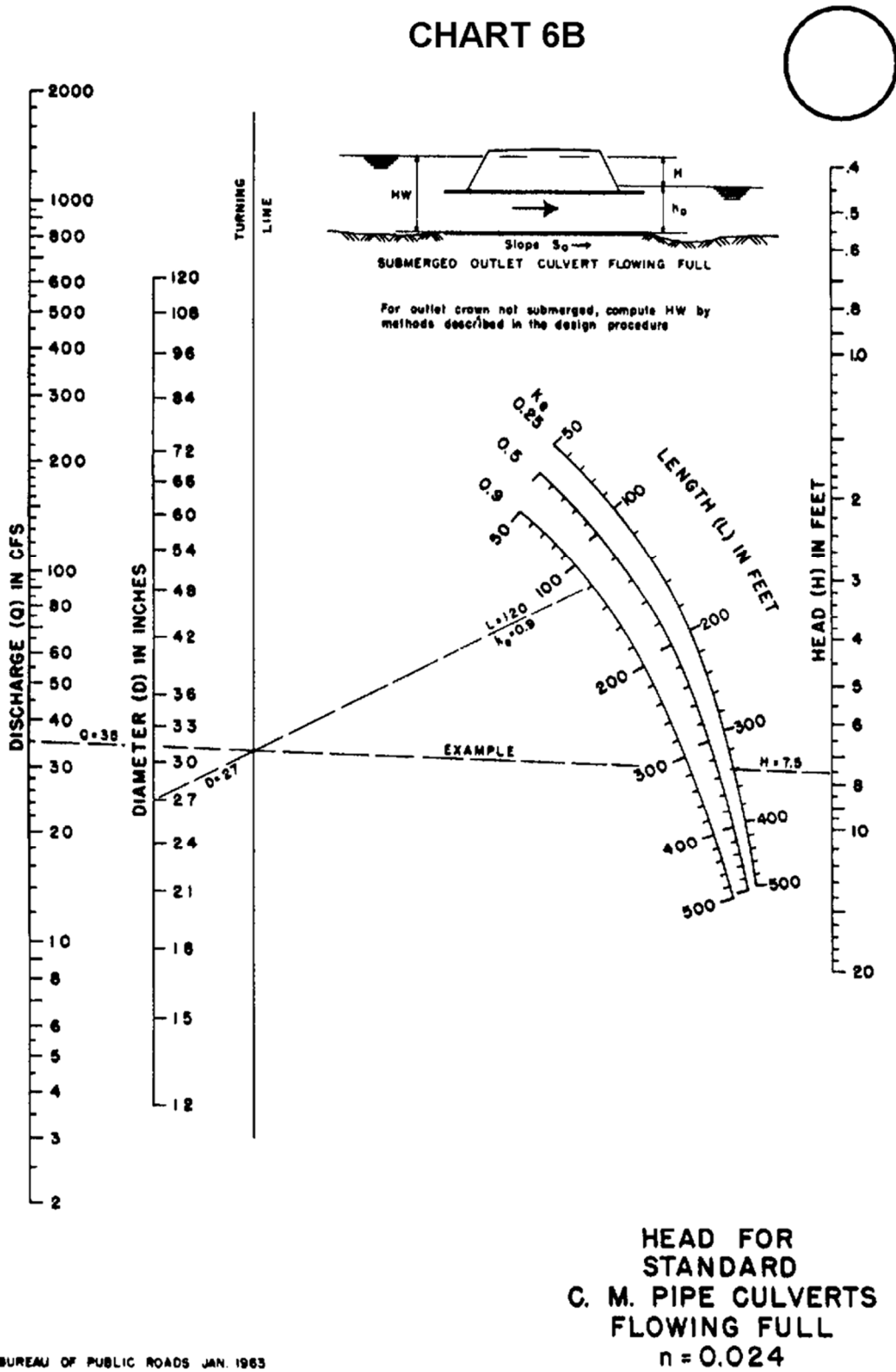

BUREAU OF PUBLIC ROADS JAN. 1963

Figure 9.14-H — HEAD FOR STANDARD C. M. PIPE CULVERTS FLOWING FULL (n = 0.024)

CHART 7B

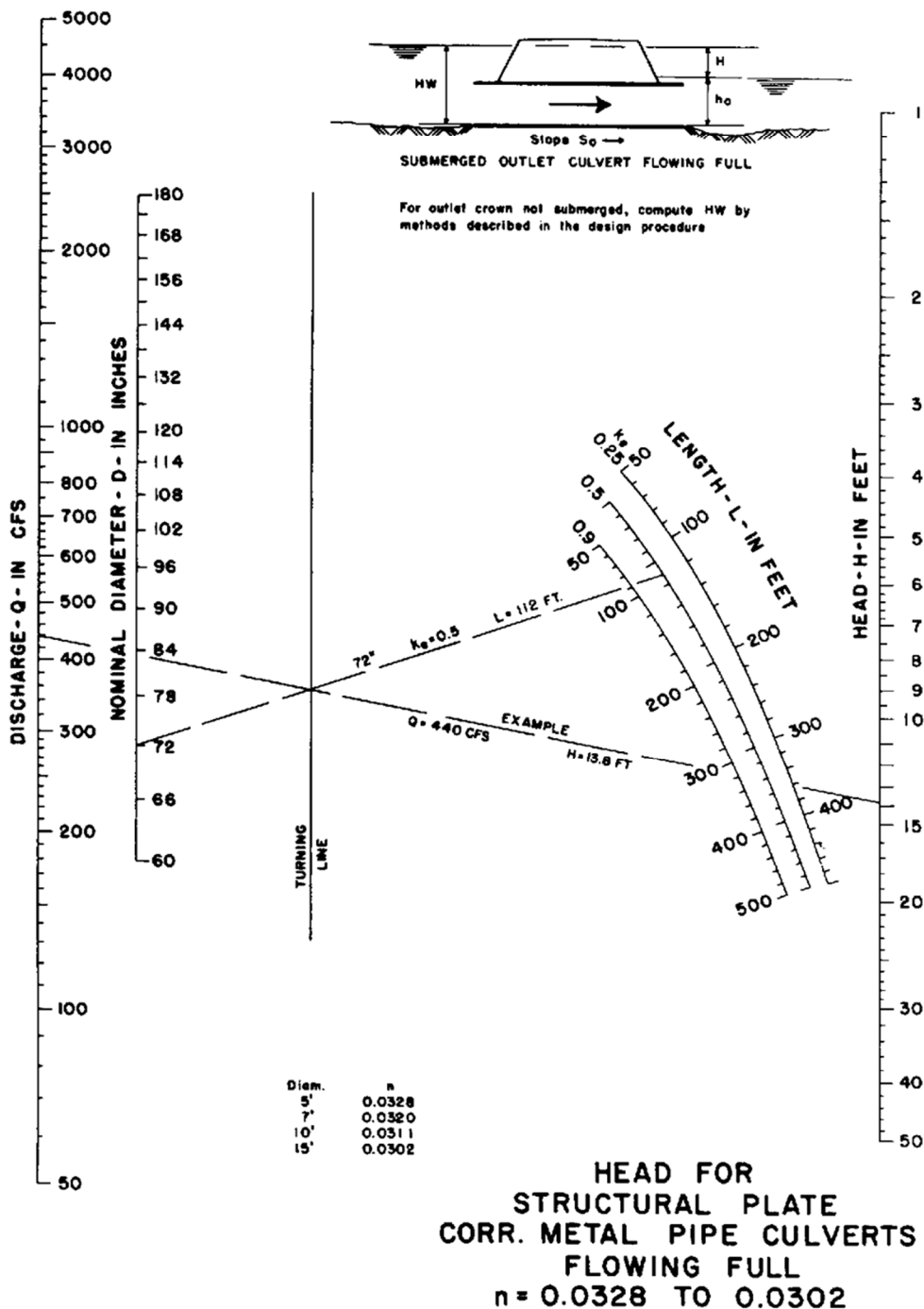
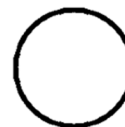

BUREAU OF PUBLIC ROADS JAN. 1963

Figure 9.14-I — HEAD FOR STRUCTURAL PLATE CORRUGATED METAL PIPE CULVERTS FLOWING FULL (n = 0.0328 to 0.0302)

CHART 8B

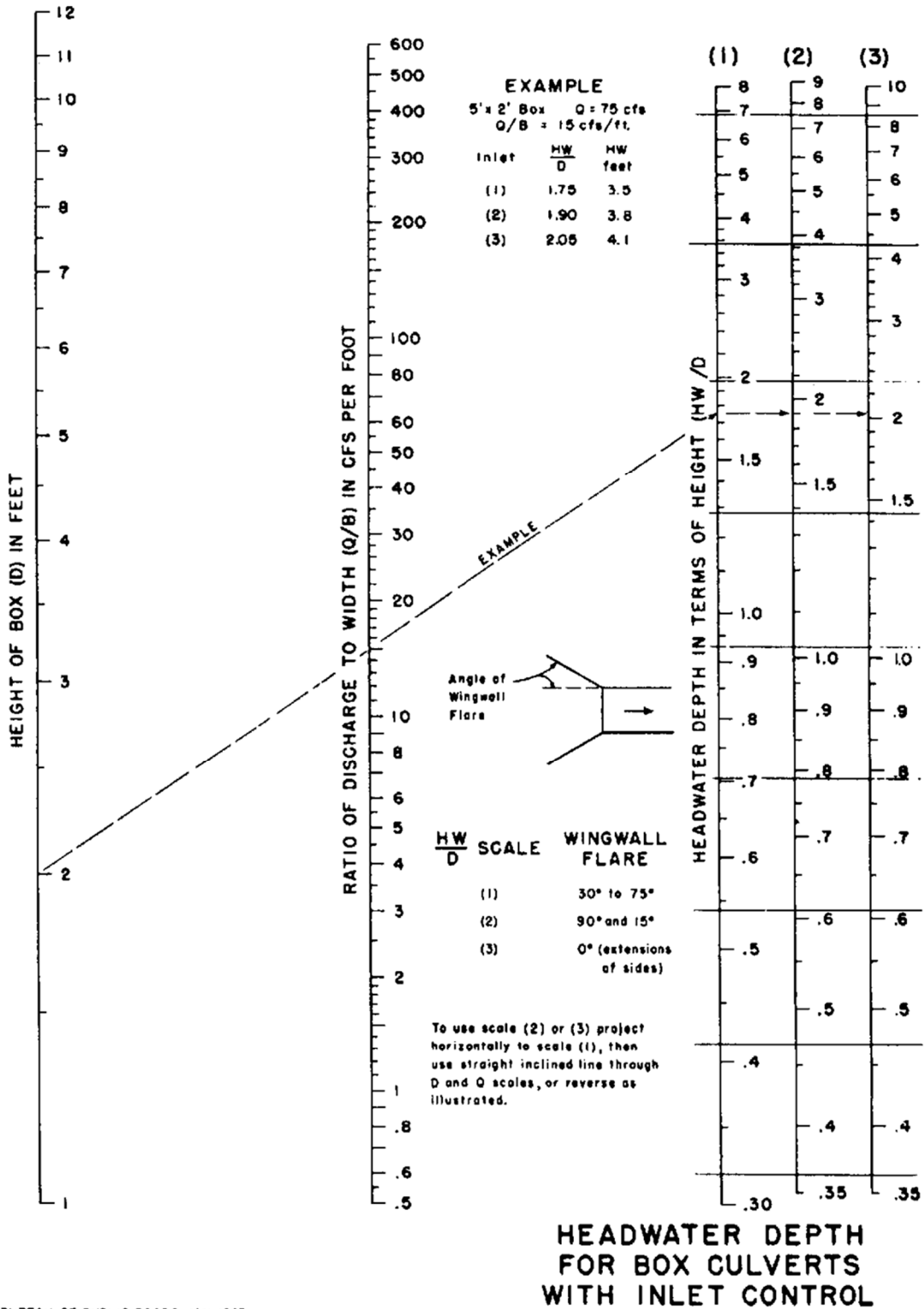

BUREAU OF PUBLIC ROADS JAN. 1963

Figure 9.14-J — HEADWATER DEPTH FOR BOX CULVERTS WITH INLET CONTROL

CHART 9B

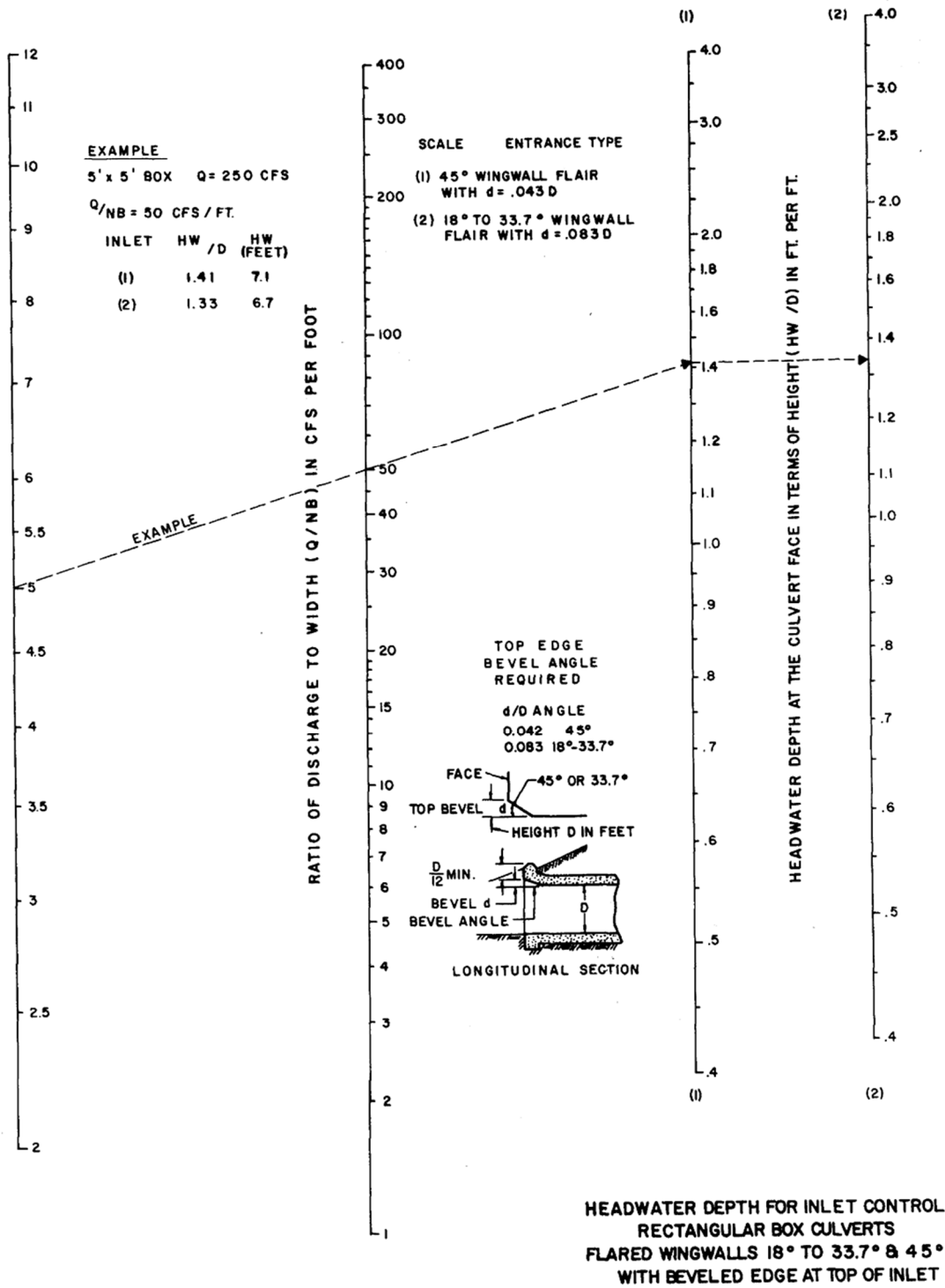

Figure 9.14-K — HEADWATER DEPTH FOR INLET CONTROL, RECTANGULAR BOX CULVERTS, FLARED WINGWALLS 18° TO 33.7° and 45° WITH BEVELED EDGE AT TOP OF INLET

CHART 10B

EXAMPLE

B=7 FT. D=5 FT. Q=500 CFS Q/NB =71.5

	HW D	HW feet
ALL EDGES	2.31	11.5
CHAMFER 3/4"	2.09	10.4
1/2 IN/FT BEVEL	1.88	9.4

INLET FACE-ALL EDGES:

1 IN/FT. BEVELS 33.7° (1:1.5)

1/2 IN/FT BEVELS 45° (1:1)

3/4 INCH CHAMFERS

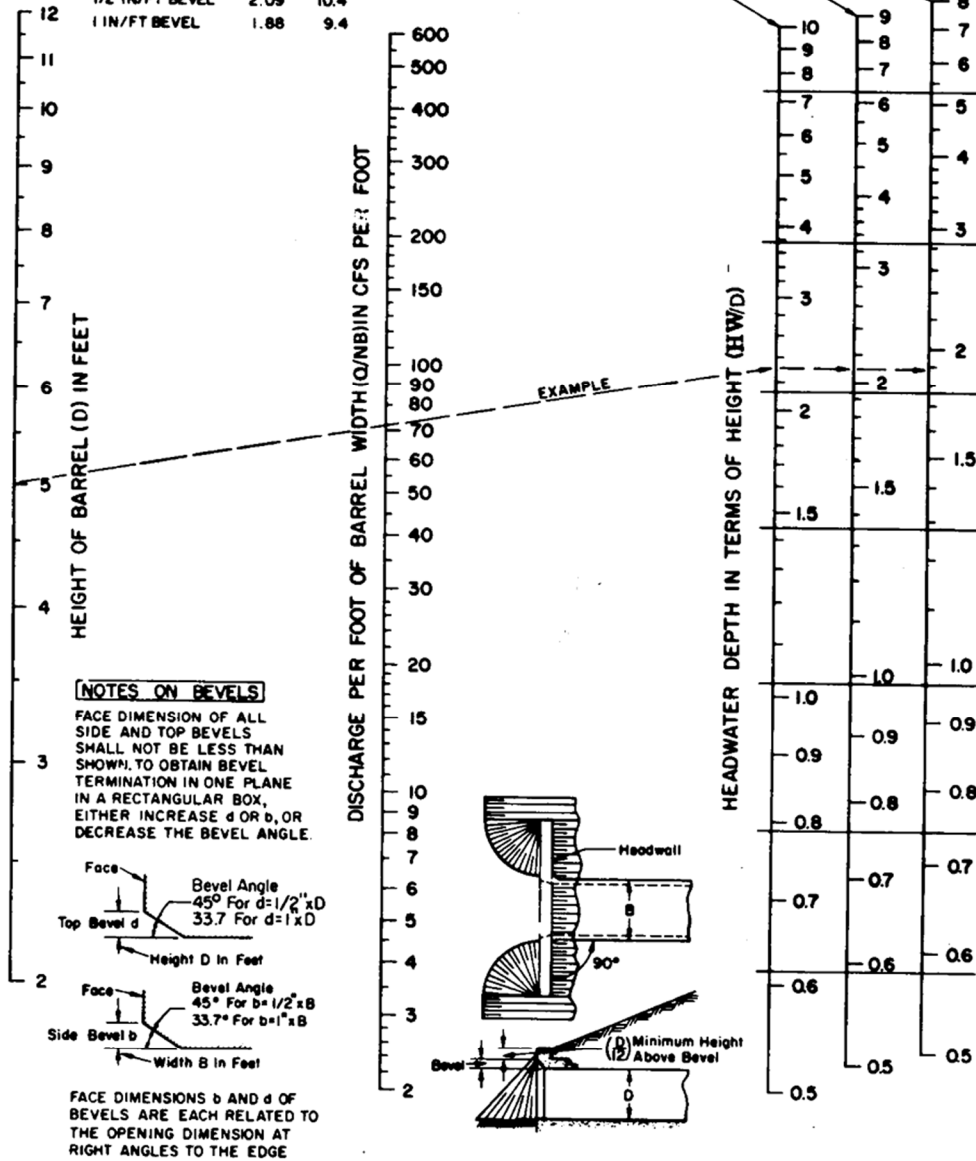

NOTES ON BEVELS

FACE DIMENSION OF ALL SIDE AND TOP BEVELS SHALL NOT BE LESS THAN SHOWN TO OBTAIN BEVEL TERMINATION IN ONE PLANE IN A RECTANGULAR BOX, EITHER INCREASE d OR b, OR DECREASE THE BEVEL ANGLE.

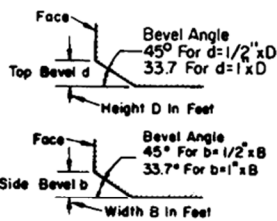

FACE DIMENSIONS b AND d OF BEVELS ARE EACH RELATED TO THE OPENING DIMENSION AT RIGHT ANGLES TO THE EDGE

**HEADWATER DEPTH FOR INLET CONTROL
RECTANGULAR BOX CULVERTS
90° HEADWALL
CHAMFERED OR BEVELED INLET EDGES**

FEDERAL HIGHWAY ADMINISTRATION
MAY 1973

Figure 9.14-L — HEADWATER DEPTH FOR INLET CONTROL, RECTANGULAR BOX CULVERTS, 90° HEADWALL, CHAMFERED OR BEVELED INLET EDGES

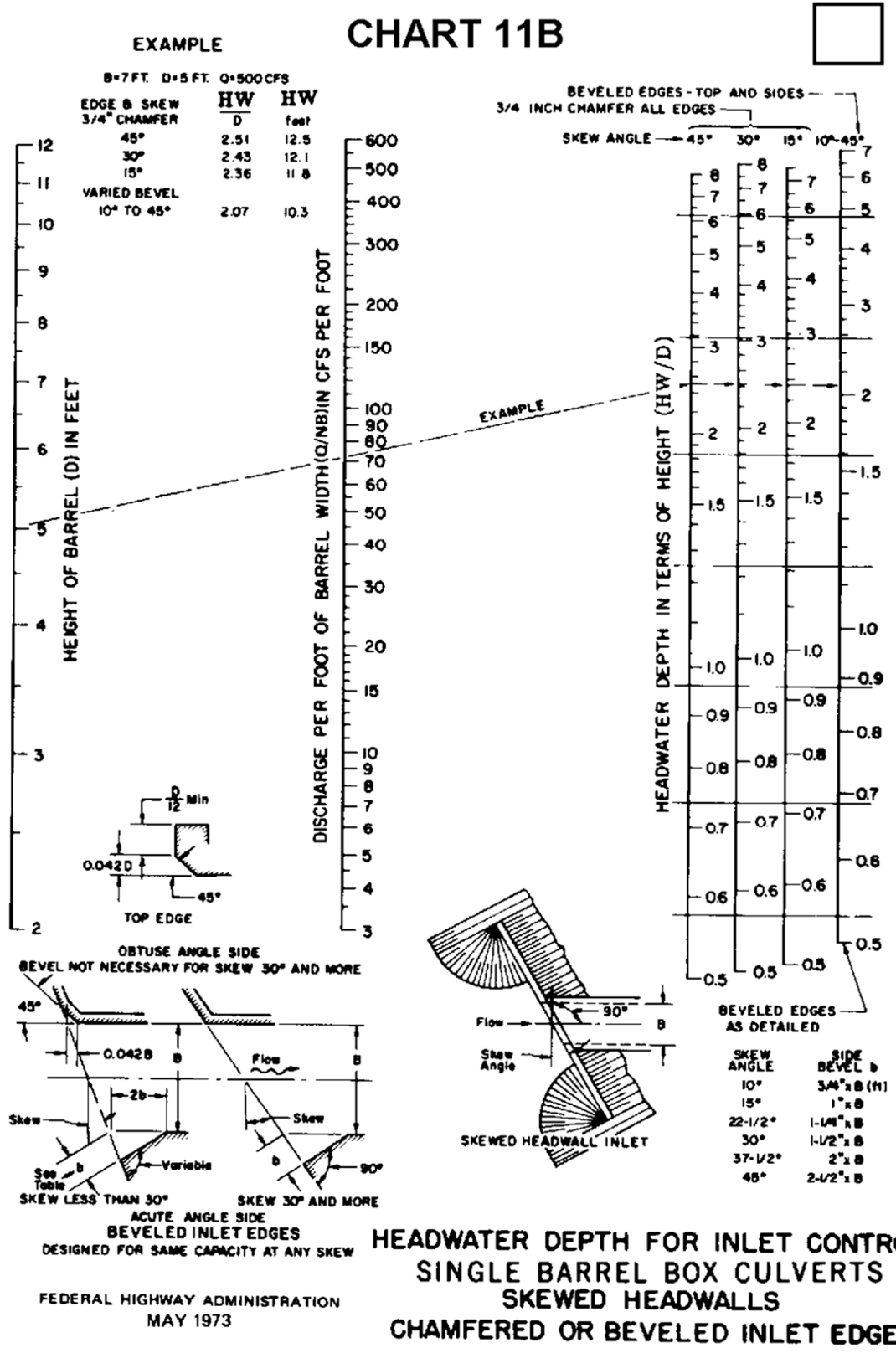

Figure 9.14-M — HEADWATER DEPTH FOR INLET CONTROL, SINGLE BARREL BOX CULVERTS, SKEWED HEADWALLS, CHAMFERED OR BEVELED INLET EDGES

CHART 12B

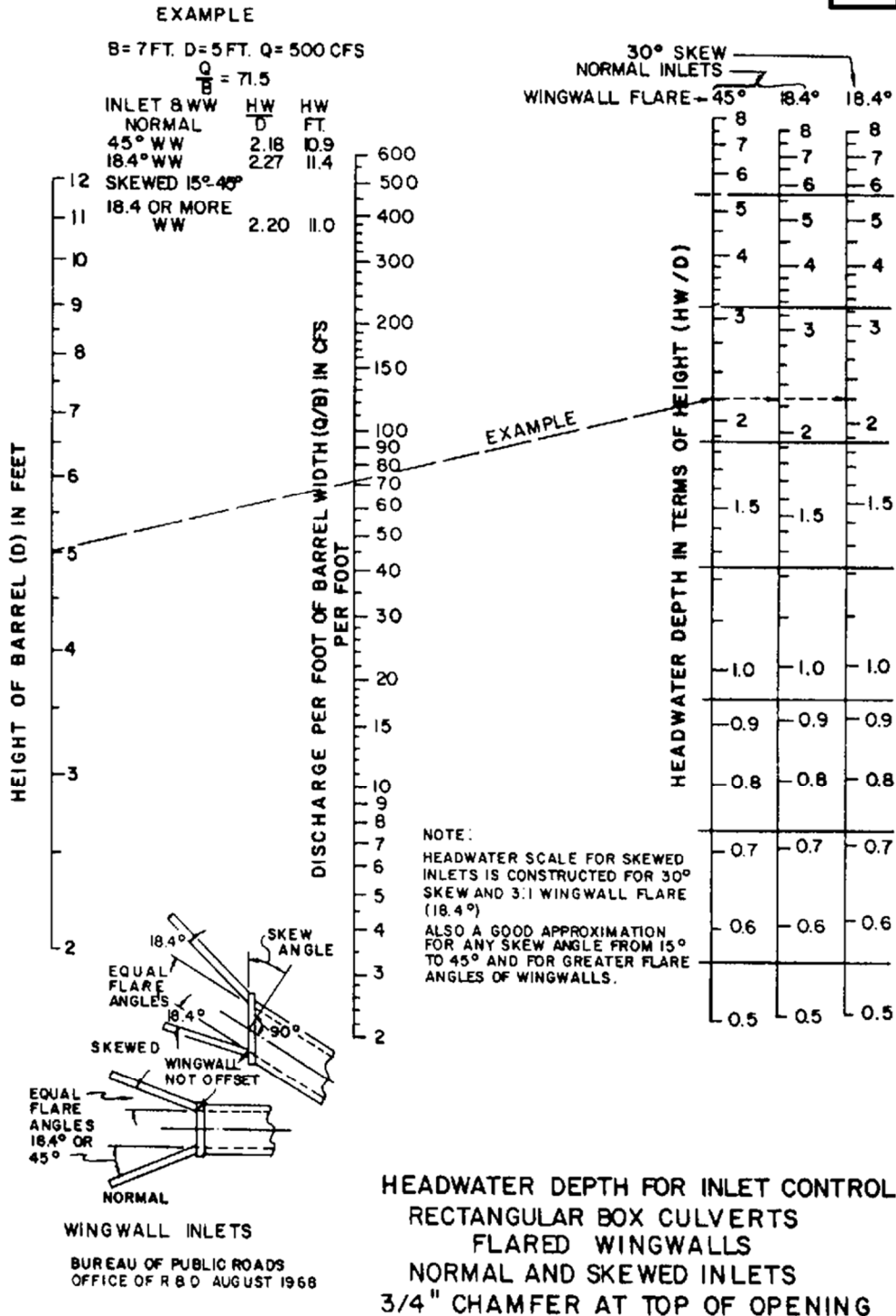

Figure 9.14-N — HEADWATER DEPTH FOR INLET CONTROL, RECTANGULAR BOX CULVERTS, FLARED WINGWALLS, NORMAL AND SKEWED INLET EDGES, 3/4" CHAMFER AT TOP OF OPENING

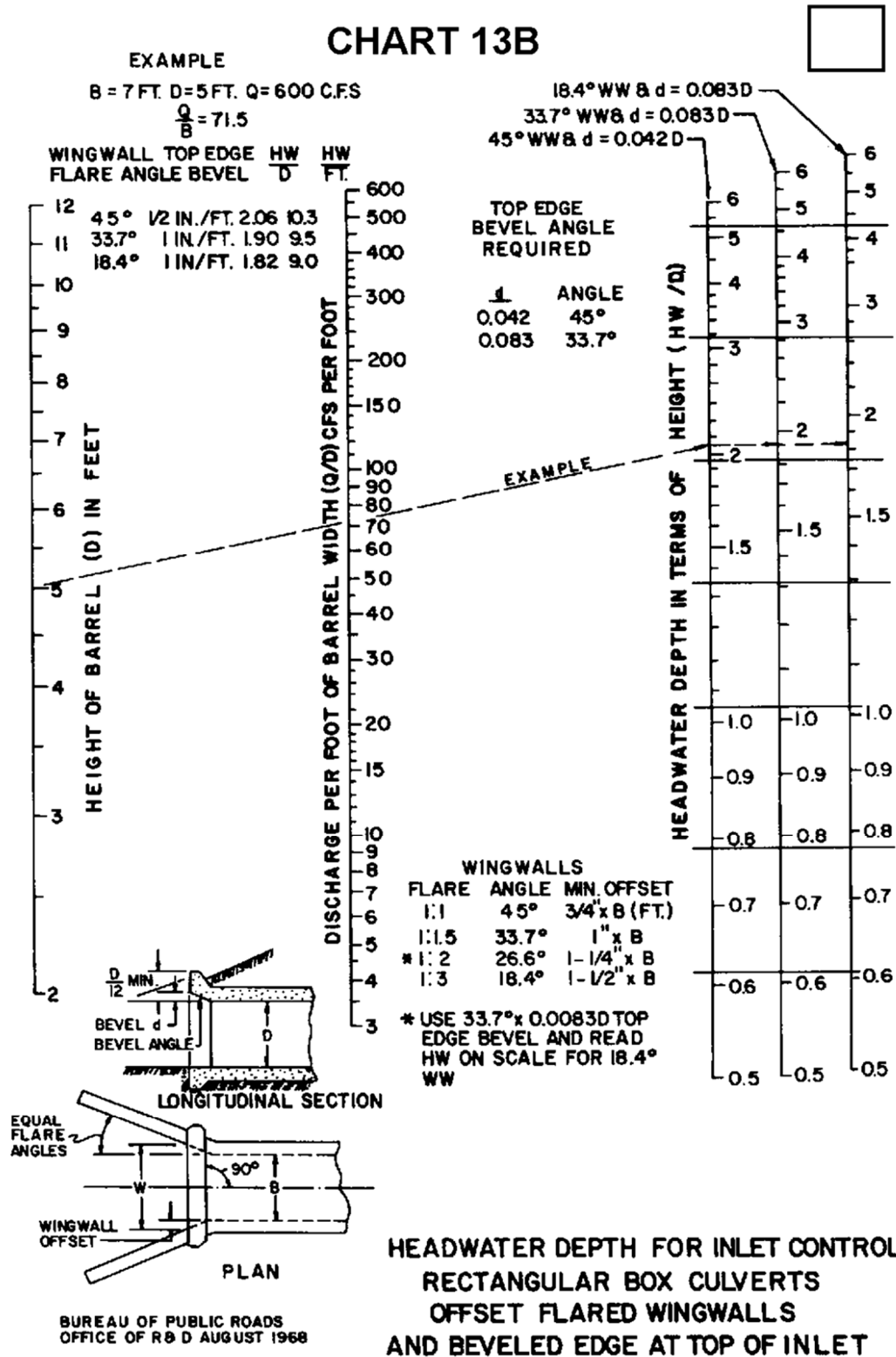

Figure 9.14-O — HEADWATER DEPTH FOR INLET CONTROL, RECTANGULAR BOX CULVERTS, OFFSET FLARED WINGWALLS AND BEVELED EDGE AT TOP OF INLET

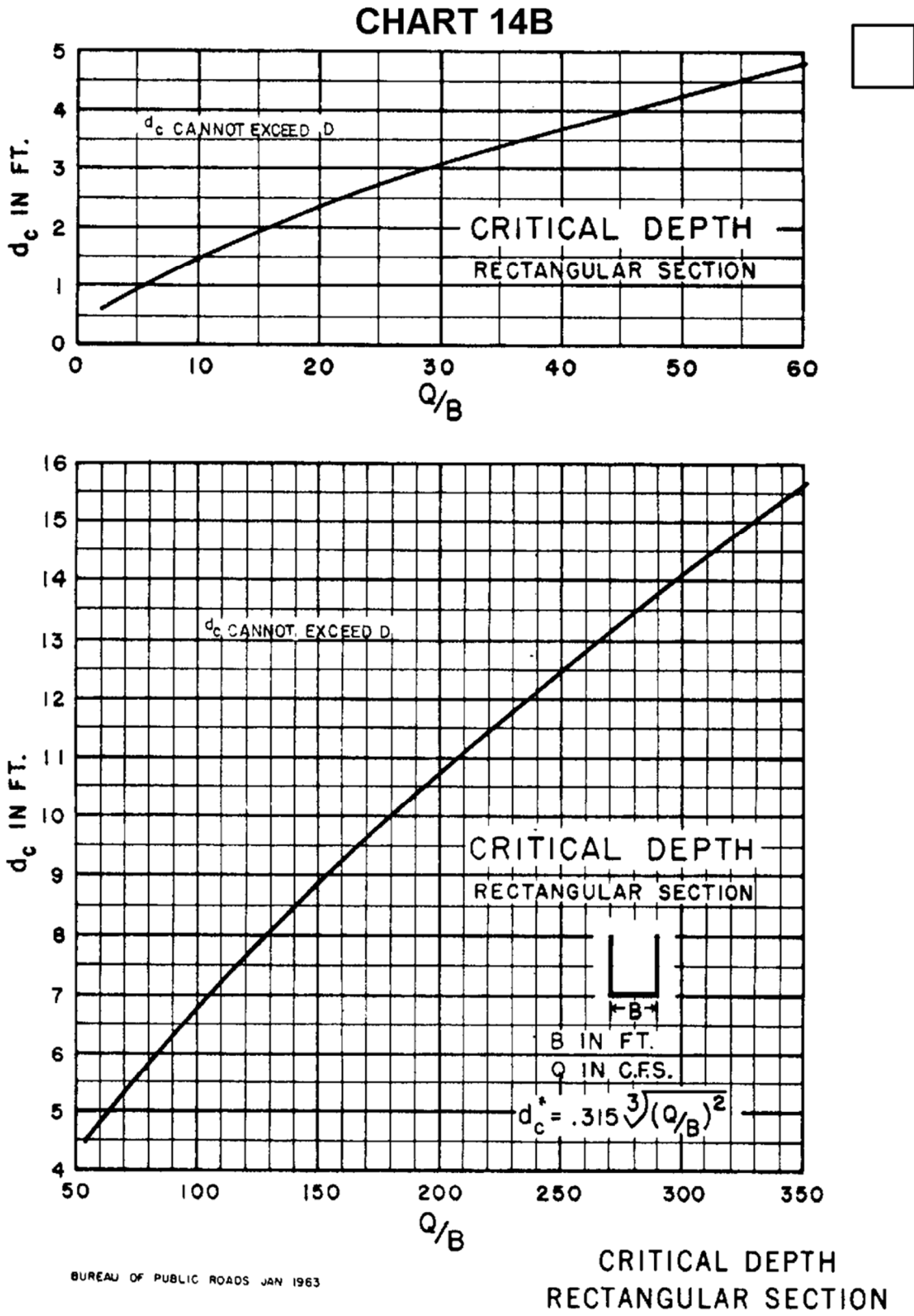
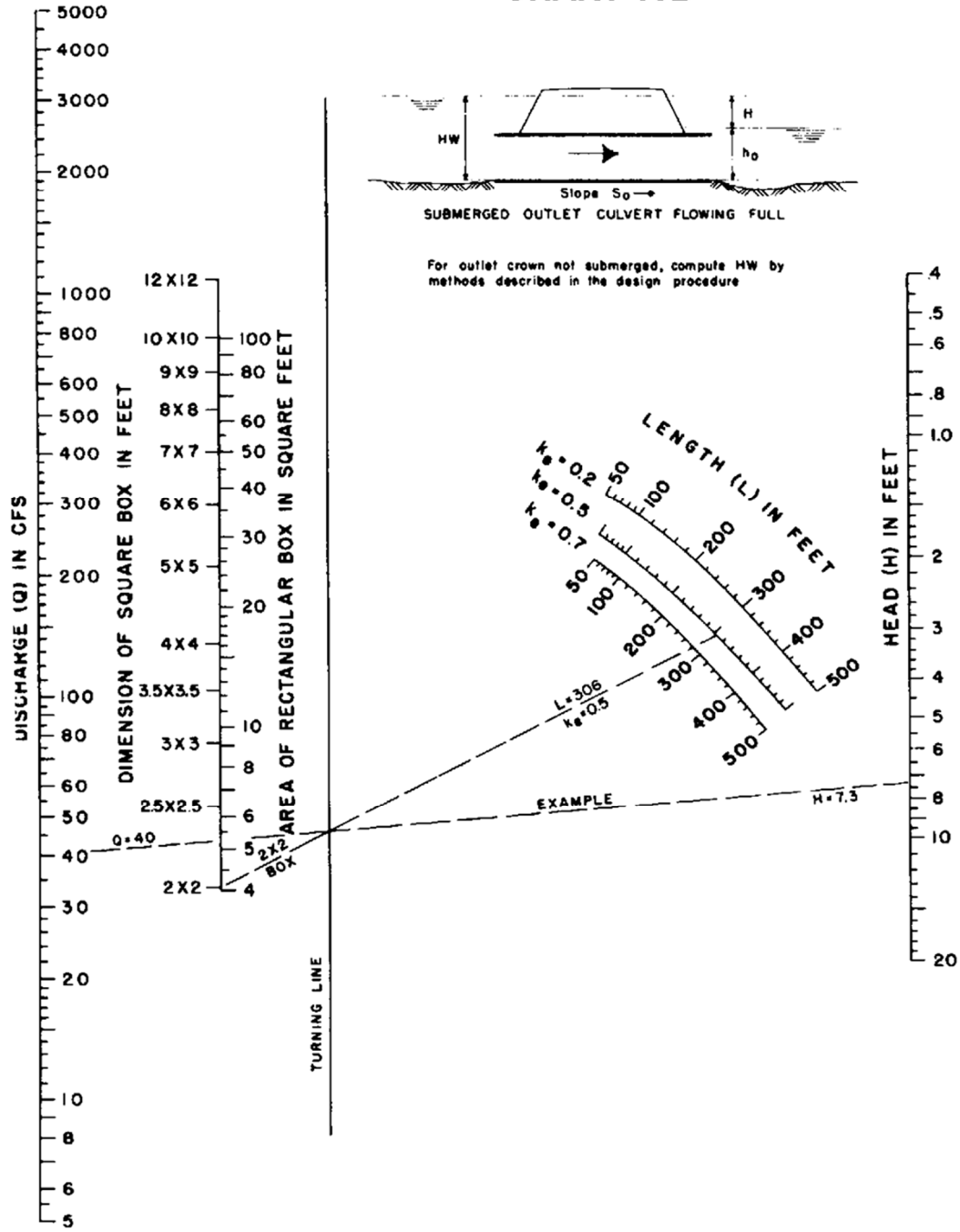

Figure 9.14-P — CRITICAL DEPTH (Rectangular Section)



CHART 15B



**HEAD FOR
CONCRETE BOX CULVERTS
FLOWING FULL
n = 0.012**

AJ OF PUBLIC ROADS JAN. 1963

Figure 9.14-Q — HEAD FOR CONCRETE BOX CULVERTS FLOWING FULL (n = 0.012)

CHART 60B

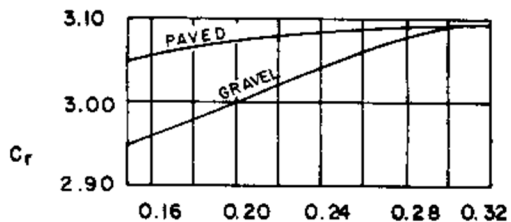
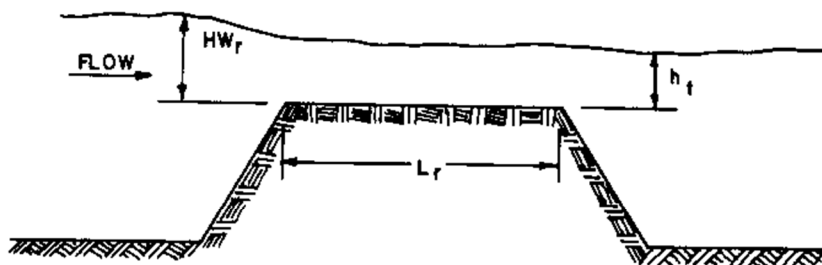

$$C_d = k_t C_r$$

$$Q_r = C_d L H W_r^{1.5}$$

A) DISCHARGE COEFFICIENT FOR $HW_r/L_r > 0.15$

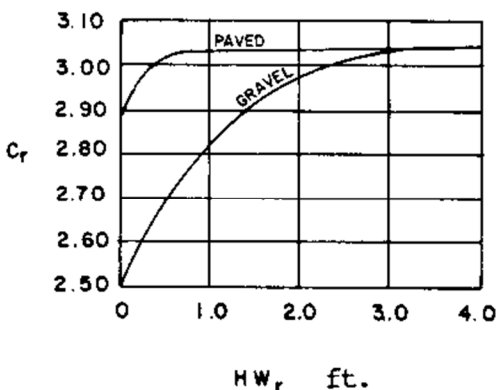

B) DISCHARGE COEFFICIENT FOR $HW_r/L_r \leq 0.15$

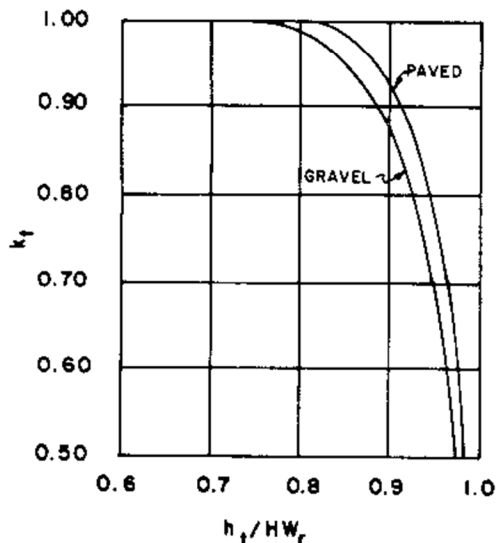

C) SUBMERGENCE FACTOR

English Discharge Coefficients for Roadway Overtopping

Figure 9.14-R — DISCHARGE COEFFICIENTS FOR ROADWAY OVERTOPPING

Figure 9.14-S — CULVERT DESIGN FORM

PROJECT: _____		STATION: _____		CULVERT DESIGN FORM	
		SHEET _____ OF _____		DESIGNER / DATE: _____ / _____	
				REVIEWER / DATE: _____ / _____	

<p style="text-align: center;">HYDROLOGICAL DATA</p> <p>See Add'l Shts.</p> <p><input type="checkbox"/> METHOD: _____</p> <p><input type="checkbox"/> DRAINAGE AREA: _____ <input type="checkbox"/> STREAM SLOPE: _____</p> <p><input type="checkbox"/> CHANNEL SHAPE: _____</p> <p><input type="checkbox"/> ROUTING: _____ <input type="checkbox"/> OTHER: _____</p> <p style="text-align: center;">DESIGN FLOWS/TAILWATER</p> <table style="width:100%; border-collapse: collapse;"> <tr> <td style="width:33%;"><u>R.I. (YEARS)</u></td> <td style="width:33%;"><u>FLOW (cfs)</u></td> <td style="width:33%;"><u>TW (ft)</u></td> </tr> <tr> <td>_____</td> <td>_____</td> <td>_____</td> </tr> <tr> <td>_____</td> <td>_____</td> <td>_____</td> </tr> </table>	<u>R.I. (YEARS)</u>	<u>FLOW (cfs)</u>	<u>TW (ft)</u>	_____	_____	_____	_____	_____	_____	
<u>R.I. (YEARS)</u>	<u>FLOW (cfs)</u>	<u>TW (ft)</u>								
_____	_____	_____								
_____	_____	_____								

CULVERT DESCRIPTION: MATERIAL - SHAPE - SIZE - ENTRANCE	Total Flow Q (cfs)	Flow Per Barrel Q / N (1)	HEADWATER CALCULATIONS										Control Headwater Elevation	Outlet Velocity	Comments	
			INLET CONTROL					OUTLET CONTROL								
			HW/D (2)	HW _i	T (3)	EL _{hi} (4)	TW (5)	d _c	$\frac{d_c + D}{2}$	h _o (6)	k _o	H (7)	EL _{ho} (8)			

TECHNICAL FOOTNOTES:

(1) USE Q/NB FOR BOX CULVERTS	(4) EL _{hi} = HW _i + EL (INVERT OF INLET CONTROL SECTION)	(6) h _o = TW or (d _c + D) / 2 (WHICHEVER IS GREATER)
(2) HW _i / D = HW / D OR HW _i / D FROM DESIGN CHARTS	(5) TW BASED ON DOWN STREAM CONTROL OR FLOW DEPTH IN CHANNEL	(7) H = [1 + k _o + (K _u n ² L) / R ^{1.33}] v ² / 2g WHERE K _u = 19.63 (29 IN ENGLISH UNITS)
(3) T = HW _i - (EL _{hd} - EL _{st}) T IS ZERO FOR CULVERTS ON GRADE	(8) EL _{ho} = EL _o + H + h _o	

<p>SUBSCRIPT DEFINITIONS:</p> <p>a. APPROXIMATE f. CULVERT FACE ha. ALLOWABLE HEADWATER hi. HEADWATER IN INLET CONTROL ho. HEADWATER IN OUTLET CONTROL i. INLET CONTROL SECTION o. OUTLET sf. STREAMBED AT CULVERT FACE tw. TAILWATER</p>	<p>COMMENTS / DISCUSSION:</p> 	<p>CULVERT BARREL SELECTED:</p> <p>SIZE: _____</p> <p>SHAPE: _____</p> <p>MATERIAL: _____ n _____</p> <p>ENTRANCE: _____</p>
--	--	---

Figure 9.14-T — SIDE/SLOPE TAPERED DESIGN FORM

PROJECT: _____				STATION: _____				TAPERED INLET DESIGN FORM																																																																																																													
				SHEET _____ OF _____				DESIGNER / DATE: _____ / _____																																																																																																													
								REVIEWER / DATE: _____ / _____																																																																																																													
DESIGN DATA: Q _____ = _____ () ; EL _{th} _____ () EL. THROAT INVERT _____ () EL. STREAM BED AT FACE _____ () T _____ TAPER _____ : 1 (4 : 1 TO 6 : 1) STREAM SLOPE, S _o = _____ () / () SLOPE OF BARREL, S = _____ () / () S _D _____ : 1 (2 : 1 TO 3 : 1) BARREL SHAPE AND MATERIAL: _____ N = _____, B = _____, D = _____ INLET EDGE DESCRIPTION _____				Side-taper				Slope-taper				COMMENTS																																																																																																									
<table border="1" style="width:100%; border-collapse: collapse;"> <thead> <tr> <th rowspan="2">Q ()</th> <th rowspan="2">EL_{th} ()</th> <th rowspan="2">EL. Throat Invert</th> <th rowspan="2">EL. Face Invert (1)</th> <th rowspan="2">HW_f (2)</th> <th rowspan="2">HW_c E (3)</th> <th rowspan="2">Q B_r (4)</th> <th rowspan="2">MIN. B_r (5)</th> <th rowspan="2">Selected B_r</th> <th colspan="5">SLOPE-TAPERED ONLY</th> <th rowspan="2">L₁ (11)</th> <th colspan="3">SIDE-TAPERED w/ depression</th> </tr> <tr> <th>MIN. L₃ (6)</th> <th>L₂ (7)</th> <th>Check L₂ (8)</th> <th>Adj. L₃ (9)</th> <th>Adj. Taper (10)</th> <th>EL. Crest Inv.</th> <th>HW_c (12)</th> <th>MIN. W (13)</th> </tr> </thead> <tbody> <tr><td> </td><td> </td><td> </td><td> </td><td> </td><td> </td><td> </td><td> </td><td> </td><td> </td><td> </td><td> </td><td> </td><td> </td><td> </td><td> </td><td> </td><td> </td><td> </td></tr> <tr><td> </td><td> </td><td> </td><td> </td><td> </td><td> </td><td> </td><td> </td><td> </td><td> </td><td> </td><td> </td><td> </td><td> </td><td> </td><td> </td><td> </td><td> </td><td> </td></tr> <tr><td> </td><td> </td><td> </td><td> </td><td> </td><td> </td><td> </td><td> </td><td> </td><td> </td><td> </td><td> </td><td> </td><td> </td><td> </td><td> </td><td> </td><td> </td><td> </td></tr> <tr><td> </td><td> </td><td> </td><td> </td><td> </td><td> </td><td> </td><td> </td><td> </td><td> </td><td> </td><td> </td><td> </td><td> </td><td> </td><td> </td><td> </td><td> </td><td> </td></tr> </tbody> </table>				Q ()	EL _{th} ()	EL. Throat Invert	EL. Face Invert (1)	HW _f (2)	HW _c E (3)	Q B _r (4)	MIN. B _r (5)	Selected B _r	SLOPE-TAPERED ONLY					L ₁ (11)	SIDE-TAPERED w/ depression			MIN. L ₃ (6)	L ₂ (7)	Check L ₂ (8)	Adj. L ₃ (9)	Adj. Taper (10)	EL. Crest Inv.	HW _c (12)	MIN. W (13)																																																																													(1) SIDE-TAPERED : EL. FACE INVERT = EL. THROAT INVERT + 1 FT (0.3 M APPROX.) SLOPE-TAPERED : EL. FACE INVERT = EL. STREAM BED AT FACE (2) HW _f = EL _{th} - EL. FACE INVERT (3) 1.1 D ≥ E ≥ D; E = D FOR BOX CULVERTS (4) FROM DESIGN CHARTS (5) MIN. B _r = Q / (Q / B _o) (6) MIN. L ₃ = 0.5 NB (7) L ₂ = (EL. FACE INVERT - EL. THROAT INVERT) S _D (8) CHECK L ₂ = $\left[\frac{B_r - NB}{2} \right] \cdot \text{TAPER} - L_3$				(9) If (8) > (7), ADJ. L ₃ = $\left[\frac{B_r - NB}{2} \right] \cdot \text{TAPER} - L_2$ (10) If (7) > (8), ADJ. TAPER = $(L_2 + L_3) / \left[\frac{B_r - NB}{2} \right]$ (11) SIDE-TAPERED : L = $\left[\frac{B_r - NB}{2} \right] \cdot \text{TAPER}$ SLOPE-TAPERED : L ₁ = L ₂ + L ₃ (12) HW _c = EL _{th} - EL. CREST INVERT (13) MIN. W = K _o Q / HW _c ^{1.5} Where K _o = 0.35 (0.64 SI)				SELECTED DESIGN B _r _____ L ₁ _____ L ₂ _____ L ₃ _____ BEVELS ANGLE _____ b = _____ () ; d = _____ () TAPER _____ : 1 S _D = _____ : 1			
													Q ()	EL _{th} ()	EL. Throat Invert	EL. Face Invert (1)	HW _f (2)		HW _c E (3)	Q B _r (4)	MIN. B _r (5)	Selected B _r	SLOPE-TAPERED ONLY					L ₁ (11)	SIDE-TAPERED w/ depression																																																																																								
MIN. L ₃ (6)	L ₂ (7)	Check L ₂ (8)	Adj. L ₃ (9)	Adj. Taper (10)	EL. Crest Inv.	HW _c (12)	MIN. W (13)																																																																																																														

9.15 REFERENCES

1. AASHTO. *Drainage Manual*. Washington, DC : Technical Committee on Hydrology and Hydraulics, American Association of State Highway and Transportation Officials, 2012.
2. FHWA. *Hydraulic Design of Highway Culverts*, Hydraulic Design Series No. 5, 3rd Edition. Washington, DC : Federal Highway Administration, 2012. FHWA-NHI-12-028.
3. USGS. *Measurement of Peak Discharge at Culverts by Indirect Methods*, Chapter A3 Techniques of Water-Resources Investigations. Washington, DC : US Geological Survey, 1982.
4. FHWA. *Culvert Design for Aquatic Organism Passage*, Hydraulic Engineering Circular No. 26, 1st Edition. Washington, DC : Federal Highway Administration, 2010. FHWA-HIF-11-008.
5. —. *Debris-Control Structures - Evaluation and Countermeasures*, Hydraulic Engineering Circular No. 9, 3rd Edition. Washington, DC : Federal Highway Administration, 2005. FHWA-IF-04-016.
6. —. 23 CFR 650 Subpart A, *Location and Hydraulic Design of Encroachments on Flood Plains*. Available at <http://www.fhwa.dot.gov/legsregs/directives/cfr23toc.htm>.
7. AASHTO. *Highway Drainage Guidelines*, 4th Edition, Chapter 9 Guidelines for Storm Drain Systems. Washington, DC : Technical Committee on Hydrology and Hydraulics, American Association of State Highway and Transportation Officials, 2007.
8. —. *Roadside Design Guide*. 4th Edition. Washington, DC : Technical Committee on Roadside Safety, American Association of State Highway and Transportation Officials, 2011.
9. USBR. *Design of Small Canal Structures*. Denver, CO : US Department of the Interior, Bureau of Reclamation, 1978.
10. FHWA. *Hydraulic Design of Energy Dissipators for Culverts and Channels*, Hydraulic Engineering Circular No. 14, 3rd Edition. Washington, DC : Federal Highway Administration, 2006. FHWA-NHI-06-086.
11. Brater, Ernest F. and Horace Williams King. *Handbook of Hydraulics*, Sixth Edition. New York : McGraw-Hill Book Company, 1976.
12. FHWA. *Urban Drainage Design Manual*, Hydraulic Engineering Circular No. 22, 2nd Edition. Washington, DC : Federal Highway Administration, 2001. FHWA-NHI-01-021.

