

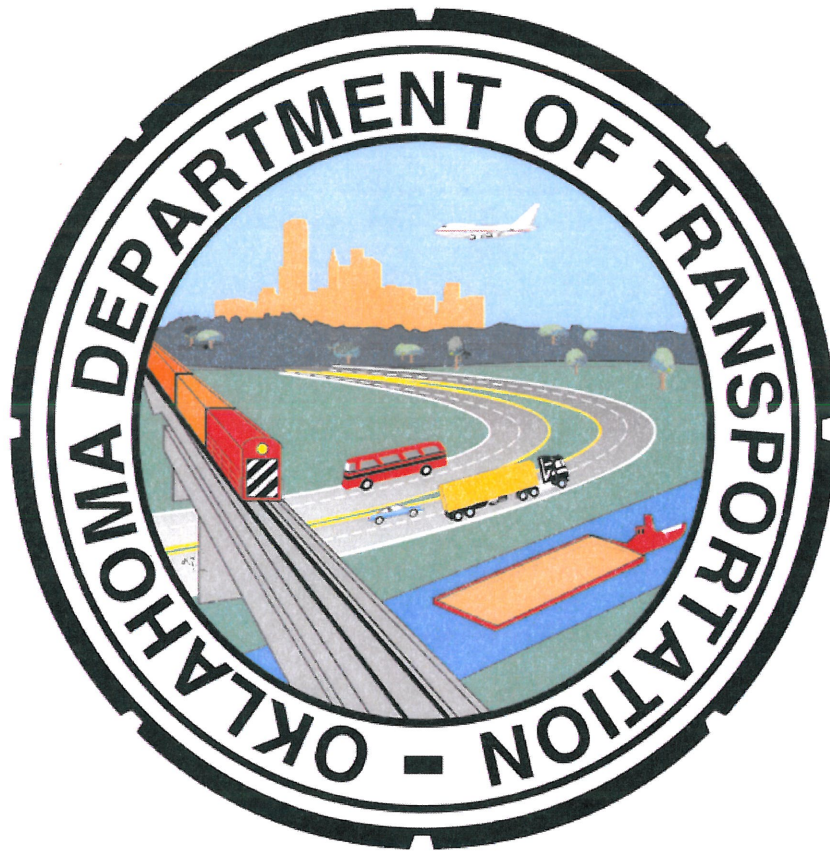

# OKLAHOMA DEPARTMENT OF TRANSPORTATION

## Guidelines for the Administration of Consultant Contracts

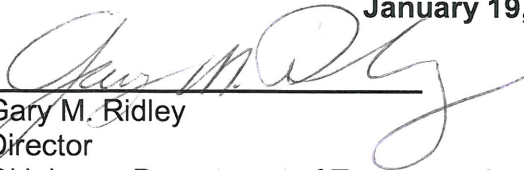

January 19, 2012

  
\_\_\_\_\_  
Gary M. Ridley  
Director  
Oklahoma Department of Transportation

  
\_\_\_\_\_  
Gary D. Corino  
Division Administrator  
Federal Highway Administration

## TABLE OF CONTENTS

<b><u>CHAPTER</u></b>	<b><u>SUBJECT</u></b>	<b><u>PAGE</u></b>
<b>CHAPTER 1.</b>	<b>INTRODUCTION .....</b>	<b>1-1</b>
1.01	Roles and Responsibilities.....	1-1
<b>CHAPTER 2.</b>	<b>CONSULTANT CONTRACT DESCRIPTIONS .....</b>	<b>2-1</b>
2.01	Contract Types .....	2-1
2.02	Contract Protocols .....	2-1
<b>CHAPTER 3.</b>	<b>CONSULTANT SOLICITATION PROCEDURES.....</b>	<b>3-1</b>
3.01	Justification for Professional Services Contracts .....	3-1
3.02	Identification of Funding.....	3-1
3.03	Contract File Preparation.....	3-1
3.04	General Scope of Services Development.....	3-2
3.05	Solicitation of Interest .....	3-2
3.06	Consultant Response .....	3-4
<b>CHAPTER 4.</b>	<b>CONSULTANT SELECTION PROCEDURES .....</b>	<b>4-1</b>
4.01	Short-List Development .....	4-1
(a)	Department Consultant Selection Committee Determination.....	4-1
(b)	Letters of Interest/Response Packet Evaluations .....	4-1
4.02	Technical Proposal – Interview Presentation.....	4-2
4.03	Scope of Services Clarification .....	4-2
4.04	Interview Evaluation.....	4-2
4.05	Debriefing for Consultants Not Selected.....	4-4
<b>CHAPTER 5.</b>	<b>CONTRACT DEVELOPMENT .....</b>	<b>5-1</b>
5.01	Detailed Scope of Work .....	5-1
5.02	Pre-Negotiation.....	5-1
5.03	Fee Proposal .....	5-1
5.04	Overhead Rates.....	5-1
5.05	Negotiation .....	5-2
5.06	Final Fee Proposal.....	5-3
5.07	Transportation Commission Approval.....	5-3
5.08	Execution of the Contract .....	5-3
5.09	Federal Authorization.....	5-4
5.10	Contract Allotment Establishment.....	5-4
5.11	Notice to Proceed .....	5-5
<b>CHAPTER 6.</b>	<b>CONTRACT ADMINISTRATION.....</b>	<b>6-1</b>
6.01	Monitoring and Control .....	6-1
6.02	Consultant Evaluations .....	6-1
6.03	Stop Work Notification .....	6-2
6.04	Task Order.....	6-2
6.05	Invoice Procedures .....	6-4
6.06	Costs Incurred Outside the Legal Contract.....	6-5
6.07	Supplementing Engineering Contracts .....	6-5

6.08	Contract Closeout.....	6-6
6.09	Contract Documentation .....	6-7
6.10	Consultant Information Webpage .....	6-7
6.11	Federal Acquisition Regulations (FAR).....	6-8
6.12	Plan Errors and Omissions .....	6-8
<b>CHAPTER 7.</b>	<b>DISADVANTAGED BUSINESS ENTERPRISE PARTICIPATION..</b>	<b>7-1</b>
7.01	Contract DBE Goals .....	7-1
7.02	Advertised DBE Participation.....	7-1
7.03	Contract Performance.....	7-1
7.04	Commercially Useful Functions .....	7-1
7.05	Monitoring of DBE Consultants.....	7-2
7.06	Substitution/Replacement of DBEs.....	7-2
7.07	Prompt Payment.....	7-2
7.08	Required Assurances .....	7-2
<b>CHAPTER 8.</b>	<b>SMALL PURCHASE THRESHOLD CONTRACTS.....</b>	<b>8-1</b>
8.01	Small Purchase Threshold.....	8-1
8.02	Method of Procurement .....	8-1
<b>CHAPTER 9.</b>	<b>LOCAL PUBLIC AGENCY CONTRACTS .....</b>	<b>9-1</b>
9.01	LPA Contract Monitoring.....	9-1
9.02	Solicitation Phase .....	9-1
9.03	Selection Phase.....	9-1
9.04	Contract Development Phase.....	9-2
9.05	Contract Administration Phase .....	9-2
9.06	LPA Program Monitoring .....	9-3
9.07	Training.....	9-3
<b>CHAPTER 10.</b>	<b>APPENDICES .....</b>	<b>10-1</b>
3.01	Justification for Professional Services Contact	
3.04	Consultant Deliverables	
3.05.01	Solicitation of Interest	
3.05.02	Professional Service Information Form	
3.06.01	DCS-CAP Form 255	
3.06.02	Solicitation Response	
4.01.a.01	Consultant Selection Committee Approval	
4.01.a.02	Nondisclosure Statement for Evaluation Team	
4.01.b.01	Short-List Selection Criteria	
4.01.b.02	Short-List Ranking	
4.01.b.03	Short-List Approval	
4.01.b.04	Interview Rejection Letter	
4.02	Interview Notification Letter	
4.04.01	Interview Selection Criteria	
4.04.02	Interview Ranking	
4.04.03	Consultant Selection Approval	
4.04.04	Consultant Selection Notification	
4.04.05	Consultant Rejection Letter	
5	Contract Template	

5.02	Pre-Negotiation Notification
5.03.01	Contract Cost Estimate
5.03.02	Negotiation Notification
5.07	EC Commission Item
5.08	Full-oversight Federal-aid Contact Execution
5.10	Request for Encumbrance
5.11	Notice to Proceed
6.02	Consultant Performance Evaluation Worksheet
6.04.01	Task Order - Request for Services
6.04.02	Construction Management / Inspection Task Order - Request for Services
6.04.03	Consultant Request for Task Order Approval
6.04.04	Consultant Request for Task Order Approval Construction Management / Inspection
6.04.05	Task Order Notice to Proceed
6.05.01	Consultant Invoice
6.07.01	Contract Supplement
6.07.02	Contract Supplemental Commission Item
6.12.01	Reporting Matrix for Scope Modifications and Changed Site Conditions
6.12.02	Reporting Matrix for Design Errors and / or Omissions and Construction Management / Construction Inspection Errors and / or Omissions
7.05	DBE Report
9.01	LPA Contract Monitoring
9.02	LPA Approval to Solicit
9.03	LPA Approval to Select
9.06.01	LPA Contract Delegation
9.06.02	LPA Contract Delegation Renewal
9.06.03	LPA Contract Delegation Removal
A-1	Contract Administration WBS
A-2	Contract Administration Workflow

## **CHAPTER 1. INTRODUCTION**

This publication provides assistance to Department personnel in the procurement and administration of consultant contracts. It is intended for wide circulation to Department personnel and the consultant community. These guidelines are crafted to provide insight into the methodology for procuring and administering consultant contracts and have been prepared to conform to pertinent State and Federal laws, rules and regulations.

Normally, consultant contracts are required to assist the Department of Transportation in meeting the transportation improvement program. The initiating division (Field Division and/or a Central Office Division) is responsible for participation in the various functions in the procurement and administration of consultant contracts.

Every step of the consultant selection and administration process is predicated on the goal of producing a quality transportation improvement for the public at a fair and reasonable cost, within the project schedule. This publication will guide you through the following steps that make this possible:

- Selecting Consultants
- Preparing Consultant Contracts
- Administering Consultant Contracts

A number of items listed in this publication are identified as confidential. These include selection results prior to publishing, a consultant's overhead rate and individuals' roster payroll rates. Good judgment is to be exercised at all times in order to allow all consultants an equal opportunity for doing business with the Department, while maintaining their individual integrity. Once the Department has fully executed a legal contract, it is viewable by the public. The Department's authority to conduct the consultant selection process and execute consultant contracts is provided by State Law at Title 69 O.S. § 708.2, Oklahoma Administrative Code 730:30-5-1 and Federal Regulations at 23 CFR § 172.5.

### **1.01 Roles and Responsibilities**

Since the procurement of contractual work and services requires a specialized knowledge of laws, regulations, program needs, policies and specific procedures, contract documents are subject to review by numerous individuals both within and outside of the Department. Some of the roles and responsibilities of primary players in this process are as follows:

- Division Office
  - The eight Field Divisions, the ten Engineering Divisions, or the Materials Division of the Central Office normally constitute the initiating divisions for the majority of ODOT's contract actions.
- Project Management Division/Contract Administration Section
  - An office tasked with the administration of the consultant services procurement process and with maintaining and applying the provisions of these guidelines.

- Consultant
  - A privately-owned entity interested in providing engineering and architectural services in response to information published by the Department of Transportation in order to assist the Department in accomplishing its mission.
- Comptroller's Office
  - Representatives tasked with overseeing the Department's financial operations to ensure conformance with fiscal requirements.
- Office of General Counsel
  - Representatives tasked with overseeing the Department's legal operations to ensure conformance with applicable rules, regulations and laws.
- Transportation Commission
  - Commissioners appointed by the Governor with responsibility for overseeing the Department's operations and to carry out the legal mandate of the Legislature.
- Federal Highway Administration (FHWA)
  - Agency responsible for ensuring compliance with applicable Federal laws and regulations consistent with the provisions of the FHWA – ODOT Oversight Agreement.
- Operations Review and Evaluation (OR&E)
  - An office responsible for audit or review of consultants' indirect cost rates and may also perform an agreed upon procedures review of completed contracts and task orders.
- Department's Consultant Selection Committee (DCSC)
  - The Department's Consultant Selection Committee will be composed of Department representatives with knowledge and expertise in the contract procurement guidelines.
- Local Public Agency (LPA)
  - Any city, county, township, municipality or other political subdivision that may be empowered to cooperate with the Department in transportation matters.

## **CHAPTER 2. CONSULTANT CONTRACT DESCRIPTIONS**

### **2.01 Contract Types**

The Department has two (2) basic forms of Consultant Contracts:

- **Project Specific Contract**
  - A Consultant Contract that provides for a general project location and a specific definition of the anticipated services that will be required. These services may include the conduct of investigations and inspections and the production of documents, studies or reports and may culminate in the development of Plans, Specifications and Estimates (PS&E) in support of the referenced projects.
  
- **Demand Service Contract**
  - Requires a Consultant to provide work and services on an as-needed or on-call basis. Demand Service Contracts are solicited with reference to general transportation services or construction management / inspection services without specifically identifying the projects for which the work will be performed. These services include the conduct of investigations and inspections and the production of documents, studies or reports and can culminate in the development of Plans, Specifications and Estimates (PS&E) in support of subsequently identified projects. Those Demand Service Contracts that encompass all the general transportation services necessary to provide a complete PS&E submission shall be limited to the contract amount established by the Oklahoma Transportation Commission. Task Orders will be generated to stipulate the work and services required for specific projects.

When used in this publication, the term 'Consultant Contract' will refer to one or both of the above defined contracts. Consultant contracts are typically bound by time and compensation and new task orders will not be issued after the expiration of the contract.

### **2.02 Contract Protocols**

Depending on the configuration of the entity entering into the legal contract with the Department, certain protocols must be observed in order for it to be legally enforceable:

- **Consultant Contracts with Individuals (Sole Proprietorship)**
  - A Consultant Contract with an individual will show the individual as the Consultant. A Consultant Contract with an individual doing business as a Consultant shall be signed by that individual in his own name and that individual will need to identify himself or herself as "Owner".
  
- **Consultant Contracts with Partnerships**
  - A Consultant Contract with a partnership will show the partnership name as the Consultant. The Consultant Contract needs to be signed by only

one partner if the authority of that partner to bind the partnership has been established. This individual should identify himself as “Partner”. The agreement establishing the authority of the partner to bind the partnership, including whether the partner is a “general” or “limited partner” must be submitted to the Department.

- Consultant Contracts with Corporations
  - A Consultant Contract with a corporation will show the corporate name as the Consultant. Individual(s) authorized to sign on behalf of the corporation will sign and indicate their official capacity. Unless the Consultant Contract is signed by a chairman, president, vice-president, chief executive officer or chief operating officer, a copy of the corporate resolution or by-laws authorizing the individual to sign on behalf of the corporation must be submitted and a copy must be on file with the Department.
  
- Consultant Contracts with Joint Ventures
  - A Consultant Contract with joint ventures may involve a corporation and a partnership and an individual or other combination. In these instances, one entity will need to be identified as the lead entity in the Letter of Interest and any ensuing legal documents. This lead entity will enter into the legal contract on behalf of the joint venture, and must sign in accordance with individuals, partnerships, or corporations above. The individual or individuals that have been granted authority to sign on behalf of all participants must provide a copy of the Joint Venture Contract stating this.



## **CHAPTER 3. CONSULTANT SOLICITATION PROCEDURES**

The Department's Consultant Solicitation Procedures include the identification and justification of services that need to be performed by external resources, determination of funding for the services, development of the scope of services, the subsequent notification to all qualified Consultants and their responses.

### **3.01 Justification for Professional Services Contracts**

It is the policy of the Department to contract for professional services when one or both of the following conditions exist:

- The inability to complete the required work within the desired time frame with available resources.
- The work requires specialized experience or expertise that is not available within the Agency.

The Department should proceed with requesting the establishment of a contract based on the following considerations:

- Consultant work and services are needed to support the Department's mission.
- The Department's in-house capability was considered and assessed in consideration of workload or a lack of specialized expertise.
- There is reasonable certainty that the Department has committed to programming adequate funds to complete the Consultant Contract.
- Knowledgeable Department personnel are available to monitor and manage the Consultant to ensure compliance with the terms and conditions of the Consultant Contract.

The Department's Chief Engineer or designee shall review and approve or disapprove the Request for Consultant Services and will notify the Project Management Division of the results.

The Department will maintain this documentation as part of the Consultant Contract file (Appendix 3.01).

### **3.02 Identification of Funding**

The Department determines the source of funds for the contract. Typical sources of funding include: The construction work plan division budget, federally budgeted engineering funds, state budgeted engineering funds, State Planning and Research funds (SPR), railroad funds or transit funds. Federally budgeted engineering funds can only be used on projects eligible for associated funding categories.

### **3.03 Contract File Preparation**

When the Contract Administrator (CA) receives the approved request for a contract, a Consultant Contract File will be created for filing all documentation directly relevant to

the selection of the Consultant. For contracts administered through Project Management Division an Engineering Contract Number will be obtained from the Engineering Contract Tracking Database and will be utilized for tracking the contract throughout the selection process. Ultimately, one set of all Consultant Selection documentation will be recorded, packaged and archived for future reference.

### **3.04 General Scope of Services Development**

Following the identification of projects and services that require resources beyond that of the Department's ability to perform, The Department will begin the development of Scope of Services (SOS). The SOS will include the following items:

- ODOT Division
- County(ies)
- Job Piece Number (if available)
- Type of Contract (Preliminary Engineering, Specialized Services, Data Collection, etc.)
- Location and description of project (if applicable)
- Type of services to be performed by both ODOT and the Consultant
- Estimated construction contract cost

Additional information may be provided as deemed necessary by the Department (Appendix 3.04). The initiating division will review the SOS.

### **3.05 Solicitation of Interest**

When the need to procure professional services has been determined and justified, funding identified and the SOS developed, a Solicitation of Interest (SOI) will be prepared (Appendix 3.05.01).

This document will include the following information:

- A description of the type of contract
- The anticipated number of contracts to be awarded
- A detailed description of the anticipated SOS sufficient to allow consultants to generate an informed Response Packet
- Specialized qualifications required to perform the contract tasks
- The major factors or criteria for the establishment of a reduced candidate list
- The anticipated starting date of the contract(s)
- A statement that the Department encourages responses from small firms, minority firms, and firms who have not previously performed work for the Department
- The Disadvantaged Business Enterprise Goal, if any
- Deadline for response to the advertisement
- A request for special requirements CAP Form 255 or equivalent form
- Number of copies required for each Response Packet
- Point of Contact for that solicitation

Note: The total number of contracts awarded may differ from the number of anticipated contracts and follow the process outlined in Section 4.04.

Solicitations of Interest will be posted on the Department's website. When the solicitation has been prepared, an email notification describing the contents of the solicitation as well as an explanation about the electronic issuance will be sent to the Department's list of Consultants and any email error messages received will be resolved through telephone contact with the Consultant firm.

The Department maintains a list of all Consulting firms that have previously submitted a Professional Services Information Form. The blank form is located on the Department's website and the Department will advertise the website biannually in a national publication or appropriate forum to allow interested consulting firms to receive future email notifications. The form includes company information such as office location(s), professional licensure, services offered and personnel contact information indicating the desire to receive notification via email. This information is required to be updated whenever the Consultant firm changes any of the data provided on the form (Appendix 3.05.02).

It is recognized that there may be special circumstances where the required services are of such unusual or specialized nature that the existing pool of consultants do not have the expertise. In those cases, the Department will make every attempt to solicit for these services in a manner that will provide for the greatest number of qualified Consultants. If it is determined that too few qualified consultants have submitted a LOI, the consultant contract may be re-advertised or the Department may continue with consultant evaluation and interviewing for the award of the consultant contract. In these situations a recommendation will be made to the Chief Engineer for approval, with adequate justification, by the DCSC for the continuation of the evaluation and interviewing process. The number of response packets needed to fulfill the minimum number of responses needed to ensure a qualified based selection process will be dependent on the number of anticipated contracts but be no less than three (3). A consultant contract may be developed when too few LOIs have been submitted if the DCSC can establish that re-advertisement of the contract is not in the public's interest and that too few responses were received. If no fewer than three (3) LOIs were received from interested consultants, the process described in the proceeding sections must be followed. If fewer than three (3) LOIs were received or the conditions of 23 CFR 172 can be proven, only required on federally funded consultant contracts, the consultant contract may be developed by direct negotiations with a single consultant. The DCSC must make a recommendation, with adequate justification, to the Chief Engineer for approval for the development of the consultant contract using direct negotiations. This documentation will be kept in the contract file. Consultant contracts entered into direct negotiations will follow typical contract development processes upon approval from the Chief Engineer.

NOTE: All Consultant firms that have submitted a Professional Service Information Form will be issued SOIs and do not have to submit annual qualifications. Qualifications will be determined at the time SOI Response Packets are received.

### 3.06 Consultant Response

A Letter of Interest (LOI) is a Consultant's response to a Solicitation of Interest. Interested Consultants respond to the request for SOI by providing the following information:

- Letter of Interest with reference to the specific Contract(s) of interest.
- Proposed Table of Organization of the project team clearly identifying the role and responsibilities of the Project Principal, the Project Manager, key staff and sub-consultants.
- Information that is common to each Contract as requested in the SOI
- The statement of qualifications including any specialized qualifications identified in the SOI (CAP 255 or equivalent) (Appendix 3.06.01).
- Identification of strategy to meet the DBE goal

The Department uses the LOI with the Consultants' Response Packet(s) submitted by the Consultant team to generate short-listing analysis data. Consultant qualifications will be determined each time they submit an LOI that includes a CAP Form 255. Resumes provided in the CAP Form 255 should include team information on the manager or technical expert level that is specific to each project and/or service listed in the LOI.

**NOTE: The Department will not accept an LOI after the close of business on the due date.**

LOI documents should comply with all SOI requirements. If applicable, the initiating division will address any noncompliance in their evaluations. Consultants are expected to follow detailed instructions such as policy manuals, governmental regulations, etc., during the fulfillment of the contract requirements and the development of Department projects.

For contracts administered by Project Management Division, each consultant's response packet is logged electronically to record the Firms' name, Contract Number of interest and the date received (Appendix 3.06.02).

## **CHAPTER 4. CONSULTANT SELECTION PROCEDURES**

### **4.01 Short-List Development**

#### **(a) Department Consultant Selection Committee Determination**

The Department will establish a candidate list consisting of all the firms that have submitted an LOI. A copy of the list will be posted on the Department's website and provided to the Department Consultant Selection Committee (DCSC).

The DCSC will review the LOIs submitted by each Consultant. The DCSC is a working committee which consists of a minimum of three (3) representatives (Committee Chair and two (2) members) and is generally determined by the different components of a project (i.e. roadway design, bridge design, survey etc.). The DCSC will be composed of Department representatives with knowledge and expertise in critical aspects of the projects and/or services, and are generally recommended by an Assistant Chief Engineer or other Department personnel requesting specialized services for Chief Engineer concurrence and Director approval (Appendix 4.01.a.01).

Ethical considerations mandate that any individual who has a potential conflict of interest with any of the firms submitting an LOI should not participate in this review and each member of the DCSC will be required to complete a Nondisclosure Statement when deemed necessary by the Director of Transportation (Appendix 4.01.a.02). A fair and impartial evaluation of the LOI is a basic requirement of the qualification-based selection process.

#### **(b) Letters of Interest/Response Packet Evaluations**

Each member of the DCSC will confidentially evaluate the submissions and merits of each LOI and Consultant's Response Packet based on the advertised selection criteria (Appendix 4.01.b.01). The Committee Chairman will determine which Consultants should be recommended for short-listing based on the DCSC evaluation. Issues to be considered during the evaluation may include, but are not limited to the following:

- Experience and/or familiarity of the proposed Consultant Team with Department procedures.
- Ability of the Consultant Team to perform the type of work contemplated.
- Specialized qualifications of the Consultant Team applicable to the type of work contemplated.
- Capacity of the Consultant Team to accomplish the work in accordance with the anticipated schedule considering current workloads.
- Past performance of the Consultant Team.

The results of each committee member's review should include, at a minimum, the reviewer's name and the score for each Consultant for each established criteria. These reviews must be documented in spread sheets, working papers, matrices or other means (Appendix 4.01.b.02). To assist in the assessment of past performance, the DCSC will receive copies of past performance evaluation forms, if available, for each of

the Consultants. Documentation of Consultants considered and the Committee's recommendation along with all supporting documentation shall be maintained in the contract file.

From the list of Consultant teams which submit acceptable LOIs, a short-list of a minimum of the three (3) highest ranking Consultants for each contract is developed for further consideration. If less than three (3) consultants submitted an acceptable LOI, the process described in Section 3.05 will be followed.

The Department's Contract Administrator (CA) provides the Committee's recommendations for Assistant Chief Engineer concurrence and Chief Engineer approval (Appendix 4.01.b.03). After the DCSC's recommendations are approved, the CA sends a notification to the short-listed Consultants of their interview and a written notification is sent to those who were not short-listed (Appendix 4.01.b.04). A courtesy copy of the approved short-list is provided to FHWA for full-oversight Federal-aid projects.

#### **4.02 Technical Proposal – Interview Presentation**

The Technical Proposal is an integral part of the Consultant Selection process. Once the short-list has been finalized, those Consultants will be notified and requested to prepare and present a detailed Technical Proposal to the DCSC. The notification will identify the major factors / evaluation criteria that will be used in evaluating the Technical Proposals (Appendix 4.02).

#### **4.03 Scope of Services Clarification**

When a Consultant is creating a Technical Proposal for their interview there may be times when a Consultant will need clarification about the SOS. The Department's contact person should review the question and submit the answer to all of the Consulting Firms that were short-listed. Under no circumstances will the Department change the SOS for a contract after issuance of the SOI.

#### **4.04 Interview Evaluation**

The Department will conduct interviews with all the short-listed consultants and no less than the three (3) highest ranked consultants. If less than three (3) consultants submitted an acceptable LOI, the process described in Section 3.05 will be followed. The DCSC generally requires oral presentations by the short-listed Consultants to further evaluate a Consultant's qualifications for most contracts.

The Consultants will be given the opportunity to explain how they intend to provide the necessary personnel, work and services to complete the services outlined in the contract. The DCSC may ask specific questions of each Consultant to clarify points concerning their qualifications submission, written proposal or oral presentation and will adhere to an established time limitation.

Following receipt of the Technical Proposals and completion of the oral presentations, the DCSC will evaluate the short-listed Consultants based on a consistent set of questions as outlined in the interview notification and rank them in order of qualifications (Appendix 4.04.01). The CA will develop a matrix of all the Committee rankings, adding them up for a final composite score (Appendix 4.04.02). The lowest ordinate total determines the selection recommendation. Ordinate total ties will be broken by the DCSC by removing the highest ordinate score given to each of the tied firms until the tie is broken. When this does not result in a tie break then total score is used as the final determination. The final interview ranking scores will accompany the recommendation letter for approval by the Director.

The DCSC may develop its own evaluation criteria based on the specific requirements of the professional services being evaluated (i.e. bridge inspection, construction management / inspection, geotechnical services, etc.) or they may use the following general evaluation criteria:

- Consultants project management approach for this contract or project.
- Ability of the Consultant Team to ensure compliance with scope limitations and scheduled milestones.
- Ability to stay within budgetary constraints of the project.
- Proposed design approach or construction management / inspection approach, staffing commitment, and solution(s) for this Contract demonstrating an understanding of the Contract requirements.
- Initiative and innovation as demonstrated by the introduction of unique concepts.

Whatever evaluation criterion is used by the DCSC, it must not deviate from the SOS issued with the SOI and must be provided to the short-listed Consultants at the time they are given notification and requested to prepare and present a detailed Technical Proposal.

Based upon the DCSC's evaluation of the proposals and oral presentations, a final ranking is established and the CA provides the Assistant Chief Engineer's recommendation for Chief Engineer concurrence and Director approval (Appendix 4.04.03). When multiple contracts are identified in a single response packet in the SOI the expected number of contracts will be validated and adjusted up or down as necessary following the interview evaluations based on but not limited to the Consultant teams ability to provide ample resources to ensure compliance with the scope of work and scheduled milestones. The highest ranked Consultant(s) is notified by the CA and are asked to submit a detailed Scope of Work (SOW) proposal as detailed in Chapter 5 of these guidelines (Appendix 4.04.04). The CA will also send letters to the Consultants who were not selected (Appendix 4.04.05). If the highest ranked Consultant(s) is not asked by the Department to submit a detailed SOW, a detailed explanation of the reasons for the decision will be provided for the Contract files. A copy of the approved final ranking is provided to FHWA for all full-oversight Federal-aid projects. FHWA concurrence in deviations from the DCSC final ranking is to be received prior to request of the Consultant(s) to submit a detailed SOW.

#### **4.05            Debriefing for Consultants Not Selected**

Consultants not selected, may request a debriefing. Information given must be factual and precise, and presented in a manner that intends to help the Consultant improve future submissions.

Under no circumstances will the Department provide the Consultant with another Consultant's proposal. Consultants will not be informed of the individual or collective scores compiled in the Contract file.

**NOTE: Copies of debriefing notes should be treated as confidential information.**



## **CHAPTER 5. CONTRACT DEVELOPMENT**

The Department shall initiate contract negotiations with the selected firm. In those cases where, as provided in the SOI, the Department intends to award two or more Contracts, separate negotiations may be conducted simultaneously with two or more firms which have the highest final composite scores.

A sample contract template is included in this document (Appendix 5).

### **5.01 Detailed Scope of Work**

The Scope of Work (SOW) is an integral part of the Contract Development process. The SOW is one of the major factors affecting the fee for consultant services since it defines the nature of and volume of services to be performed. A well written SOW establishes the tasks to be performed, materials to be delivered, meetings to be attended, schedule to be met, standards that will be followed, and responsibilities of both the Consultant and the Department.

### **5.02 Pre-Negotiation**

The CA will request the selected Consultant to submit in detail their understanding of the SOW to include work activities, tasks, schedules and deliverables and Sub-Consultants that will be involved in the Contract (Appendix 5.02). The CA will schedule and facilitate a pre-negotiation meeting with the Department's technical experts, Project Manager and Consultant to clarify the SOW. Once a mutual agreement of the SOW is accepted, a negotiation meeting will be established.

### **5.03 Fee Proposal**

Once the revised SOW has been received and approved by the Department, the Consultant will submit a Fee Proposal based on the tasks established in the SOW, detailing costs for all Contract components (Appendix 5.03.01). The Fee Proposal shall be submitted and evaluated on an hourly basis, unless otherwise requested by the Department. The Department will also prepare an estimate of the fee based on the tasks established in the SOW. The Consultant's Fee Proposal will be compared to the Department's estimate. The Department has the option of allowing the selected firm to perform under a lump sum contract. When lump sum payment methods are proposed the basis of fee will be developed using an hourly rate, cost plus fix fee, unit of work, or other appropriate methods. If necessary, the CA will establish a time and place to negotiate the fees (Appendix 5.03.02).

### **5.04 Overhead Rates**

Prior to the negotiations, the CA will request that the Consultant submit their Firm's Certified Overhead Rates for review by Department personnel. Depending on the

method of payment for a Consultant's Contract Part, overhead costs are evaluated accordingly:

- Cost Plus Fixed Fee
  - The Consultant will use its certified overhead rate to develop its Fee Proposal to establish a budget and for invoicing.
- Hourly Rate of Compensation
  - The Consultant will use its certified overhead rate to develop its Fee Proposal to establish a budget. The Specific Rate Factor developed at the time of execution of the Contract will be used for the life of the Consultant Contract. The overhead rate for Contract Supplements will be that established with the initial Consultant Contract, unless otherwise requested by the Consultant and approved by the Department.
- Lump Sum
  - The Consultant will use its certified overhead rate to develop its Fee Proposal to establish a budget. If a Supplement is needed, the same method will be used during the processing of the Supplement.
- Cost Per Unit of Work
  - The Consultant will use its certified overhead rate to develop its Fee Proposal to establish the Unit Costs and budget. The Specific Rate Factor developed at the time of execution of the Contract will be used for the life of the Consultant Contract. The overhead rate for Contract Supplements will be that established with the initial Consultant Contract, unless otherwise requested by the Consultant and approved by the Department.

**NOTE: Consultants' overhead rates are confidential.**

## **5.05 Negotiation**

Negotiations are intended to lead to the development of a Contract mutually satisfactory to the Department and the selected Consultant. The objective of evaluating and negotiating a Consultant Contract is to reach a fair and reasonable cost for the work and services to be provided by the Consultant. A complete and mutual understanding of the detailed SOW should exist. Effective negotiation requires the exercise of judgment, tact and common sense.

The final resolution of all issues should consider the long range effect on the mutual relationship which a Consultant Contract ought to reflect. Items normally negotiated include:

- Contract schedule to be included in the contract
- Products to be delivered
- Classification, hours and experience level of personnel to be assigned to this contract
- Cost items, total cost of contract, and profit/fixed fee
- Sub-Consultant costs

Negotiation meetings will convene at the Department. Department staff from pertinent units, particularly the individuals who helped in the development of the SOW and Department Estimate, and key staff from the selected Consultant will attend.

During the negotiation process, each task and sub-task will be discussed to determine how it is to be accomplished, the expected deliverable, and its format. If the Consultant's understanding is not in accord with that of the Department, discussion will be conducted to arrive at a mutual understanding of the task(s) to be accomplished, the method by which it will be accomplished, and the final product. Confirmation in the form of a modification of the SOW to reflect the agreed-to terms shall be reduced to writing in the final SOW of the contract.

If, following the meeting, additional comments of a minor nature arise, the Department may elect to finalize the negotiations by telephone with the Consultant. The Consultant shall be requested to document conclusions reached, whether negotiations were made in a meeting or by phone. Otherwise, the Fee Proposal will be returned to the Consultant for revision.

If agreement with the top ranked Consultant cannot be reached, the Department will formally terminate the negotiations. A pre-negotiation meeting will then be held with the next highest ranked Consultant and the above steps will be repeated. If negotiations are unsuccessful, the Department will re-solicit the Contract or abandon the effort.

The negotiation procedure for task orders is detailed in section 6.04 Task Order.

#### **5.06 Final Fee Proposal**

Following the negotiation process, the Consultant will make the additions/corrections/changes to the Fee Proposal, if necessary, and resubmit it electronically to the CA. This process will continue until the Department receives an acceptable Fee Proposal. If both parties agree on all of these items, a Contract is then processed.

#### **5.07 Transportation Commission Approval**

Following successful negotiations, if applicable, an Agenda Item shall be prepared to present to the Oklahoma Transportation Commission for approval (Appendix 5.07). This will include the Consultant Firm(s) selected and will clearly define the SOS required, the amount of payment for the Contract and estimated construction costs, if applicable.

#### **5.08 Execution of the Contract**

After review by the originating division(s) and Assistant Chief Engineer, the Consultant will be asked to review and approve with signatures. If there are any discrepancies

between the Department and Consultant, a review will be performed to revise or justify the reason that prohibits the Department from revising the Contract.

Upon receipt of the Consultant's approval signatures, the Department's approval process will commence which will include the following signatures as applicable:

- General Counsel
- Assistant Chief Engineer
- Chief Engineer
- Federal Highway Administration (FHWA) (Full-oversight Federal-aid projects only)

The following information will also be provided to FHWA for a contract on a full-oversight Federal-aid project (Appendix 5.08):

- The scope of services
- The solicitation
- Evaluation ranking
- Interview ranking
- Department's estimate for negotiation
- Contract and supplements
- All task orders

## **5.09 Federal Authorization**

Following Transportation Commission approval, the CA will submit an email request for authorization of Federal funding to the Department's Programs Division, if Federal funds are to be utilized. The following information will be provided in this request:

- Engineering Contract (EC) Number
- EC Job Piece Number
- Amount of Contract
- Date Commission approved
- General Scope of Services
- STIP Engineering Contract Line Item Notice

Once Programs Division has obtained authorization of Federal funding from FHWA, a confirmation email is sent to the CA.

FHWA approval of the contract for a full-oversight Federal-aid project is required prior to authorization of Federal funds.

## **5.10 Contract Allotment Establishment**

The CA will complete and submit a Request for Encumbrances to the Comptroller/Purchasing for Task Specific and Demand Service Contracts (Appendix 5.10). FHWA authorization is required prior to this request for federally funded Contracts. The Comptroller/Purchasing Unit will process the request and forward the Purchase Order to the CA upon issuance. For Construction Management / Inspection

Contracts, the Contract Administrator will submit a copy of the Contract to the Comptroller who will hold the Contract until a task order has been received. The Comptroller will then verify allotment availability and subsequently encumber the necessary funds for the Contract.

The Contract Administrator will maintain a database that will monitor the not to exceed value of each Contract.

#### **5.11 Notice to Proceed**

The Consultant is not allowed to begin work and services until issued a Notice to Proceed (NTP) from the Project Management Division (Appendix 5.11). The NTP will be issued to the Consultant following Commission approval of the agenda item, the signature process, authorization of Federal funds for federally funded contracts and the Contract is encumbered by the Comptroller Division.

## **CHAPTER 6. CONTRACT ADMINISTRATION**

This chapter describes the procedures to be followed for monitoring the performance of work and services by Consultants. The life of a contract begins with the Solicitation of Interest and does not end until final acceptance of the work and services effort has been accomplished and the Consultant Contract is closed with final payment to the Consultant. The CA is involved throughout the life of the Contract including the development phase. However, the administration of contracts can be defined as the management of a contract beginning at the time the Notice to Proceed is issued and ending when the contract is closed. During this time it is the responsibility of the CA to ensure adherence to all aspects of the Contract by the Consultant as well as Department personnel.

### **6.01 Monitoring and Control**

Monitoring and control are essential to ensure the Consultant uses and manages all resources in a manner that will provide the Department exactly what has been contracted for in terms of quality, timeliness and economy of cost.

The Department uses its own in-house staff (Field and/or Central Office Divisions) to manage Consultants. A highly trained staff is essential to oversee, supervise, and manage the Consultant portion of the Department's mission. Good communication between the Consultant, the Department's Project Manager (PM), and other affected parties is crucial to the success of a project. The Department establishes their PM to serve as a single point of contact to maintain open and accurate communication of all instructions and/or directions given to the Consultant. A Department wide project status system is maintained to track and status scheduled preconstruction project milestones. Deliverables from project specific contracts and demand service contracts are tracked in the system and the division responsible for the deliverable associated with the project milestone maintains the data in the system. Projects are then monitored through status reports generated from the system.

### **6.02 Consultant Evaluations**

The obligations accepted by the Consultant are stated in the Consultant Contract and satisfactory fulfillment of the obligations is implicit. Therefore, Consultant Evaluations are completed at the end of every Contract in order to document and measure performance (Appendix 6.02). These evaluations are a valuable management tool for rating the current Consultant work and services, as well as for use in the selection process for future work and services. When performing the Consultant Evaluation on task order based contracts, the Department should also consider the conduct of the Consultant team in regard to the negotiations phase.

An Interim Consultant Evaluation can be processed at contract milestones or at any time during the life of the Contract. However, a Final Consultant Evaluation must be processed for each contributing Consultant at the completion of any Contract and documented in the Contract file. The PM and CA facilitate the completion of the

evaluation form and submit it to the Consultant for their review and comments. Department staff comprising the membership of a DCSC can view all Consultant Evaluations. Consultants can only view the Evaluations for their firm.

**NOTE: Consultant Evaluations are confidential.**

### **6.03 Stop Work Notification**

In the event that the Consultant's performance is unsatisfactory, or it is deemed in the best interest of the Department to cease work and services on a Contract, the Department's Project Manager issues a written stop work notification to the Consultant. Unresolved performance issues will be addressed in accordance with Section 6.08. The Consultant may not proceed with work and services on the Contract until the Department's Project Manager provides a subsequent authorization to proceed.

### **6.04 Task Order**

The purpose of a Task Order is to supplement the basic Contract and to provide a vehicle to communicate, define, approve, authorize the services, schedule, fees, and provide funding and other parameters related to services to be provided by the Consultant. All efforts which are the Consultant's responsibility and for which the Consultant expects to be compensated must be defined in an approved Task Order. Services provided by the Consultant which have not been included in an approved Task Order or Task Order amendment will be considered gratuitous and the Department will not be obligated to compensate the Consultant for such services.

When the Department determines there is a need for the services of the Consultant; a Request for Services will be prepared (Appendix 6.04.01 or Appendix 6.04.02). The Department will consider the ability of the Consultant team to perform type of work contemplated, capacity of the Consultant team to accomplish the work in accordance with the anticipated schedule considering current workloads and past performance of the Consultant team when multiple consultant firms are available for the required services. The Request for Services will include the following:

- Contract Number, Contract JP Number, Project Description, County and Construction Job Piece Number
- Requested By
- Consulting Firm
- Proposed Method of Compensation
- A description of services to be provided through the requested Task Order
- A description of the anticipated deliverables
- A schedule to complete the requested services
- Task Order Number (Assigned by the CA prior to sending request to the Consultant)

Upon receipt of a written Request for Services and prior to preparing a Task Order, the Consultant and the Department will discuss the services to be provided under the proposed Task Order and agree generally that the instructions are clearly stated and understood. Following this verbal concurrence, the Consultant will prepare a Request for Task Order Approval (Appendix 6.04.03 or 6.04.04). The purpose of the Request for Task Order Approval is to establish specifically and in a detailed format the services to be provided, technical standards, schedule, compensation, and other parameters under which the services are to be completed.

Each Request for Task Order Approval must include the following:

- Task Order Number, County and Job Piece Number
- Consultant name and Contract Number
- Detailed, definitive, and specific SOW including project limits (if applicable) for services to be provided
- Method of Compensation and budget for the requested Task Order
- Man-hour detail including a list of tasks to be accomplished, personnel classifications, and hourly rates, overhead, other direct expenses, and fees
- List of deliverables, if applicable
- Schedule for completing SOW including all reviews and approvals by others
- Project Manager/Engineer and/or key personnel to be assigned to the contract and location where work will be completed
- Completed First Tier Sub-Consultant Participation form as provided in Attachment B2
- Signature of Consultant and the date of submittal
- A signature Block for subsequent use by the Department in the execution and recording of the date of Task Order Approval

The following process will be followed in reviewing and approving Request for Task Order Approval applications:

- The Consultant will submit the Request for Task Order Approval to the Department for review. The Department shall review the Request for Task Order Approval to determine that it accurately and definitively describes the services to be provided; deliverables; compensation and method of payment; and, if applicable, the project limits.
- Should it be determined that one or more elements of the Request for Task Order Approval are not approved by the Department, such elements shall be brought to the attention of the Consultant. Efforts will be made to negotiate an approval of the elements in question.
- After negotiations if it is determined that resolution cannot be achieved, the Department may elect to continue negotiations or elect to complete the work using its own forces or the services of others under a different contract.
- Within ten (10) working days after a Request for Task Order Approval is received, the Department will either notify the Consultant that the Task Order will be approved; identify elements which do not meet with the approval of the Department and are to be considered for negotiation; notify the Consultant that the Task Order is not being approved.
- Upon approval of a proposed Task Order, the Department and the Consultant will execute the Task Order document thereby signifying acceptance of the specific



terms and exemplified provisions therein and acknowledging the formality of this Contract. For full-oversight Federal-aid projects, FHWA must also execute the Task Order document.

- The initiating division will forward the executed Task Order to the Project Management Division for further processing including the request for authorization of funds (for Construction Management / Inspection Task Orders only) and an associated Notice to Proceed (Appendix 6.04.05).

The deliverables and services initiated through a Task Order associated with a project specific contract must be completed within the contract time identified in the contract or a subsequent contract supplement. Issuance of a Task Order is constrained by the time limitation of the contract, therefore a Task Order cannot be executed after the contract or a subsequent contract supplement has expired. The deliverables and services initiated through a Task Order associated with a Demand Service contract can extend beyond the contract time constraints identified in the contract or a subsequent contract supplement as long as the Task Order was executed prior to the expiration of the contract.

A Demand Service Task Order can also be amended to complete work identified on a previously executed Task Order. A Task Order amendment can be executed beyond the contract time constraints identified in the contract or a subsequent contract supplement. Task Order amendments will follow the same process as a Task Order and the task order number and amendment letter will be clearly identified.

## **6.05 Invoice Procedures**

This section describes the procedures to be followed for processing Consultant invoices for payment. Invoices for all Consultant Contracts are to be submitted and processed in the same manner, regardless of the type of Consultant Contract (Appendix 6.05.01).

The following methods of payment are utilized by the Department for Consultant Contracts:

- Cost Plus Fixed Fee
  - This method is used when the SOW is fairly well-defined, but the total engineering effort required to complete the work cannot be estimated precisely. The Consultant is paid an agreed-upon amount for a fixed fee, based on actual SOW completed, together with all actual costs incurred in the performance of the work and services. Once both parties have agreed to the work effort in an executed Consultant Contract, a change in the amount of fixed fee can only be made if the SOW changes.
- Lump Sum
  - This method is used when the SOW is well-defined and the total engineering effort can be estimated accurately. Once both parties have agreed to the work effort in an executed Consultant Contract, a change in the amount of the lump sum can only be made if the SOW changes significantly.
- Cost Per Unit of Work

- This method is used when the SOW is well-defined, the engineering effort per unit can be estimated accurately, and there are a repetitive number of similar units to be performed.
- Hourly Rate of Compensation
  - This method is used when the SOW and the required work effort cannot be determined at the time the Consultant Contract is executed. A specific rate of compensation is established for each employee classification by multiplying the wage rate by the specific rate factor established in each Consultant Contract.

A Supplemental Contract will be required to revise the method of payment for a Contract or a Task Order after the initial method of payment is established.

Each Division should reject or disallow any portion of the amount claimed without rejecting the entire payment. However, if a claim for payment is deemed acceptable the individual who approves the payment must sign the invoice and return it to the Project Management Division for processing. If any portion of the claim is rejected an explanation must be provided to the Consulting Firm by the rejecting Division.

If the payment is approved, but the Department personnel does not have payment signature authority they should notify a qualified individual in their Department that the payment is technically accurate and recommend that the payment be processed.

Payment for all work and services provided is sent to the prime Consultant, who in turn, is responsible for promptly paying its Sub-Consultants.

## **6.06 Costs Incurred Outside the Legal Contract**

In the event that a Consultant incurs costs outside of the constraints of its Contract, i.e. works prior to or after the Contract period, or incurs costs beyond Category of Compensation limitations, invoices requesting these costs cannot be processed by the Department.

## **6.07 Supplementing Engineering Contracts**

A Supplemental Contract allows the Department to change the terms and conditions of an approved original Contract where warranted (Appendix 6.07.01). It can also be used to extend the time of completion for a task, but is not the preferred method unless there are other terms and conditions that need to be revised as well.

Supplementing Contracts is done in order to modify the SOW, change key personnel, first tier subconsultant, increase overall funding, or to transfer funds between Categories of Compensation.

The following describes the procedures to be followed to supplement a Contract:

A change in the SOW requires the execution of a Supplemental Contract to revise the approved original Contract. This must be done prior to performance of the work and services required. Otherwise, the Consultant would be performing work and services outside the terms and conditions established in the Contract and shall not be paid for their efforts through the Contract. Additional SOW can only be added to the Contract if it is within the general context of the original advertised SOS.

When used in this publication, the term 'Scope of Work (SOW)' will refer to the tasks necessary to provide the broader 'Scope of Services (SOS)' (i.e. an Environmental Clearance is a Scope of Services and Public Involvement is a Scope of Work).

When additional funds are needed to complete the work described in the approved original Contract (i.e., when costs will overrun the originally proposed amount), a Supplement may be justified. The Department needs to consider, among others, whether the overrun was caused by a low initial Fee Proposal estimate, excessive re-work caused by the Department, re-work caused by the Consultant's poor performance, etc., when deciding whether to recommend the processing of a Supplement.

Based on the Department Estimate, Engineering Managers need to ensure that adequate funding is available or being arranged by the time the Fee Proposal is requested.

Supplements must follow the same Contract Development process (as defined in Chapter 5 of this guideline) that was applied to the development of the original Contract. The applicable Sections are as follows:

- Detailed SOW
- Pre-Negotiation
- Fee Proposal
- Negotiation
- Overhead Rates
- Final Fee Proposal
- Commission Approval (Appendix 6.07.02)
- Execution of the Contract (Supplement)
- Notice to Proceed

The Department will review/evaluate the SOW. The Department will maintain all individual comments/approvals on file. Once the SOW is acceptable to all applicable parties, the Supplement will be executed and the Department's CA will issue a NTP for the work covered by the Supplement. No costs contemplated by the Supplement can be incurred by the Consultant prior to the issuance of the NTP.

## **6.08 Contract Closeout**

Consultant Contracts are terminated if any of the following occur:

- All of the work and services to be performed under the terms of the Consultant Contract have been completed in a satisfactory manner
- The time of completion stipulated in the Consultant Contract has expired

- A closeout Supplemental Contract is executed
- The Department cancels the Consultant Contract in accordance with the terms of the Consultant Contract

Upon termination of the Consultant Contract the Consulting Firm will process a final invoice (if required). This final invoice will be the Department's notice to begin the process of closing the Contract with the Comptroller.

## **6.09 Contract Documentation**

Consultant Contract records and documentation should be maintained by the Department's CA in the project files and made available for any future audit or reference. The minimum retain time for documentation is three (3) years following payment of the Contract's final invoice. These records and documentation include, but are not limited to:

- SOI including the SOS
- Department Selection Committee's rating sheets, review comments, recommendations, and other material pertinent to the selection process
- Technical review verification/comments on the SOW and/or technical proposal
- Consultant Contract correspondence/approvals
- Negotiation Documents including the Consultant's and the Department's cost estimates
- Consultant Contract Documents
- Consultant Evaluations

## **6.10 Consultant Information Webpage**

The Department's Project Management Division maintains an internet webpage that provides information for the sole purpose of communicating the status of contract related documentation to the Consultant community.

The following information is added and updated during various phases of Contract development:

- Quarterly and Special Solicitation Packets
- Contract selection phases including:
  - Consultants submitting Letters of Interest
  - Consultants that have been selected for short-lists
  - Consultants that have been selected for contracts
- Construction Estimate Pay Item History
- Project Management Personnel Information

Additional information will be posted to the webpage when required to ensure effective communication between the Department and the Consultants.

## 6.11 Federal Acquisition Regulations (FAR)

The Consultant shall certify that the indirect cost rate submitted does not include any costs which are expressly unallowable and that the indirect cost rate was established only with allowable costs in accordance with the applicable cost principles contained in the FAR. The Department's OR&E Division will be responsible for ensuring that a Consultant's indirect cost rate complies with the FAR cost principles.

## 6.12 Plan Errors and Omissions

Changes to a project under construction can be categorized under one of four conditions, and are defined as follows:

- **Modifications in project scope** – Change Orders that result from adjustments to the scope of a project in order to address identified deficiencies and / or to accommodate additional work beyond that which is reasonably defined by the Contract documents.
- **Changed site conditions** – Change Orders that attributed to unforeseen or changed site conditions which cannot be readily anticipated during the preliminary engineering and design development process.
- **Design engineering errors or omissions** – Change Orders that become necessary as a result of errors and / or omissions in the Contract documents, plans and / or specifications which may constitute some measure of professional negligence on the part of the responsible party.
- **Construction Management errors or omissions** – Change Orders that result from errors and /or omissions which are associated with improper construction management and / or construction inspection practices which may constitute some measure of professional negligence on the part of the responsible party.

If a project experiences a Change Order as a result of one of the above listed conditions, the Department has a responsibility to notify and coordinate with the Consulting Engineer of Record, if determined necessary. Scope modifications and design alterations necessary to address changed site conditions may have a detrimental impact on the performance of the associated project element or facility. These impacts may not be readily apparent without input from the design engineer. Therefore, and at the request of the Department, the Consulting Engineer of Record has an obligation to assist in the interpretation of the plans and specifications during construction and to be a party to any associated decision making process.

If it is determined that Contract document errors and / or omissions, or Consultant construction management or construction inspection errors and / or omissions, that are discovered during the execution of a construction project have contributed to additional expenses or delay in project delivery, the Department may choose to seek reimbursement for those costs directly and indirectly attributable to those errors and /or omissions.

Expenses such as overhead, profit, labor, equipment, materials, re-work, incidentals, user costs for additional time considerations (computed per day based on the Contract

liquidated damages amounts) and Contractor delay claims may be included in the calculations for Consultant Liability. Errors and / or omissions discovered during the execution of a construction project which are anticipated to result in additional construction costs in excess of \$50,000.00, will be considered SIGNIFICANT.

In the event of discovery of the need to modify a project scope and / or the encounter of changed site conditions the documentation / notification process will follow the Reporting Matrix for Scope Modifications and Changed Site Conditions (Appendix 6.12.01).

In the event of discovery of design errors and / or omissions or construction management or construction inspection errors and / or omissions, the documentation / notification process will follow the Reporting Matrix for Design Errors and / or Omissions and Construction Management / Construction Inspection Errors and /or Omissions (Appendix 6.12.02).

## **CHAPTER 7.       DISADVANTAGED BUSINESS ENTERPRISE PARTICIPATION**

This section describes the procedures concerning Disadvantaged Business Enterprise (DBE) participation in Consultant Contracts. DBEs include Minority Business Enterprises (MBE), Small Business Enterprises (SBC), and Women Business Enterprises (WBE). Only DBEs certified by the Department's External Civil Rights Office are eligible. All issues of certification or DBE eligibility must be resolved by the External Civil Rights Office. DBE participation is required pursuant to Federal Regulations at 23 CFR § 230.201 and 49 CFR Part 26.

### **7.01           Contract DBE Goals**

The Chief Engineer or designee, in coordination with the External Civil Rights Officer, will review all U.S. DOT-assisted (Federal-aid) Consultant Contracts and other professional service contracts and determine subcontracting opportunities and the availability of certified DBEs available to perform in professional services. The Consultant Contract goal will be determined prior to the consultant interview process and the Consultants will be notified of required DBE participation.

### **7.02           Advertised DBE Participation**

If a goal for DBE participation is established for an advertised Consultant Contract, Consultants expressing interest in the Consultant Contract must agree to ensure that DBE Consultants currently certified by the Department shall have the opportunity to participate in any subcontracting. Responding Consultants shall make good faith efforts to meet the DBE goal using DBEs. If the selected Consultant fails to meet the Contract DBE goal, it must document and demonstrate a good faith effort, as defined in the ODOT DBE Program Manual, before the Department can recommend award. If the selected Consultant fails to document and demonstrate a good faith effort to meet the Contract DBE goal, the Consultant is ineligible for contract award.

### **7.03           Contract Performance**

Only expenditures to a DBE Consultant who performs a commercially useful function may be counted toward a DBE goal.

When a DBE performs as a participant in a joint venture, the portion of the total dollar value of the Contract equal to the clearly defined portion of the work that the DBE performs with its own forces may be counted toward the goal.

### **7.04           Commercially Useful Function**

A DBE performs a commercially useful function (CUF) when it is responsible for the execution of the work of its Contract and is carrying out its responsibilities by actually performing, managing, and supervising the work involved. To determine whether a

DBE Consultant is performing a CUF, the Department will evaluate the type(s) of work the DBE is contracted to perform compared to the work the DBE is certified to perform, whether the amount the firm is to be paid under the Contract is commensurate with the work it is actually performing and the DBE credit claimed for its performance of the work, and other relevant factors.

#### **7.05 Monitoring of DBE Consultants**

Once a U.S. DOT-assisted contract is awarded, the Consultant will provide the Department information as to the proposed DBE participation in the Contract, including the name, subcontract amount, and the type of work to be performed by the DBE subconsultant. The Consultant will report to the Chief Engineer or designee, amounts paid to DBE subconsultants (Appendix 7.05). The Chief Engineer or designee will forward a report stating the amounts paid to Consultants and amounts paid to DBEs to the External Civil Rights Office.

#### **7.06 Substitution/Replacement of DBEs**

Substitution or replacement of a DBE contracted as part of a proposal submitted to the Department will only be permitted or allowed after award and execution of the U.S. DOT assisted Contract, and then only in compliance with the procedures outlined in the Department's DBE Program.

#### **7.07 Prompt Payment**

To ensure that all Consultants' obligations under U.S. DOT Contracts are met, the Consultant shall pay all subconsultants for satisfactory performance of their Contracts no later than thirty (30) days after receipt of each progressive payment from ODOT. Failure to comply with prompt payment provisions of the contract may result in sanctions under the Contract up to and including termination.

Any delay or postponement of payment may take place only for good cause and must include ODOT's written approval. The explanation of good cause from the prime Consultant must be made in writing to the Department. Further, all subconsultant Contracts carry the same provisions and must include a notice to subconsultants of their right to prompt payment.

#### **7.08 Required Assurances**

Each Consultant Contract and subsequent subconsultant Contracts must include the following assurances:

The Consultant shall not discriminate on the basis of race, color, national origin, or sex in the performance of this Contract.



The Consultant shall carry out all applicable State and Federal requirements in the award and administration of Contracts. Failure by the Consultant to carry out these requirements is a material breach of this Contract, which may result in the termination of this Contract or such remedy as the recipient deems appropriate.

## **CHAPTER 8. SMALL PURCHASE THRESHOLD CONTRACTS**

### **8.01 Small Purchase Threshold**

Small purchases are those relatively simple and informal procurement methods where an adequate number of qualified sources are reviewed and the total contract costs do not exceed the simplified acquisition threshold of \$100,000.00.

Contract requirements should not be broken down into smaller components merely to permit the use of small purchase requirements.

### **8.02 Method of Procurement**

Following the identification of the need for services to be contracted outside the Department with an estimated value less than \$100,000, the requesting division develops the Scope of Services in writing and coordinates with Project Management Division to prepare a list of a minimum of three known and qualified Consultants from the Department's list of Consultants. Each Consultant on the list is solicited to provide a scope of work for the requested services, either by telephone or in writing. The Consultant's Scope of Work is documented in writing by the requesting party when solicited by telephone.

The requesting division ranks the solicited firms based on whose scope of work best meets the needs of the Department. The interview ranking scores will accompany the recommendation letter for approval by the Director. Approval of the selection is required prior to the negotiations of the fee proposal. Negotiations will be commenced with the highest ranked consultant. If the highest ranked Consultant(s) is not selected, a detailed explanation of the reason(s) for the decision will be provided for the contract file(s). The selected Consultant submits a proposed fee proposal based on the Scope of Work. A negotiation meeting is held to finalize the project Scope of Work and Fee Proposal. Submission of the fee proposal and subsequent negotiations will follow a similar process as outlined in Sections 5.03, 5.05 and 5.06. When the final Scope of Work and Fee Proposal are agreed to by both parties, a Contract is prepared for execution and processing following a similar process as outlined in Sections 5.08 through 5.11. The administration of a simplified acquisition will be subject to the same requirements for management, control, quality and other related procedures as outline in Chapter 6.

Small purchase threshold contracts may be supplemented during the administration of the contract only if the total contract value including the supplement(s) does not exceed the \$100,000 threshold. If the total contract value exceeds the \$100,000 threshold then the services must be solicited in accordance with the procedures identified in Chapters 3-5.

Small purchase threshold contracts may follow a simplified acquisition. Therefore, the FAR auditing requirements are not required. However, if the audits are readily available, they should be used.

The following documentation is maintained in the Contract file for each small purchase completed under the procedures in this section:

- The Scope of Services
- The name, address, Federal Employer's Identification (FEI) number, and telephone number of each solicited Consultant Firm
- The date of the solicitation and the name (first and last) of the Consultant representative providing the Scope of Work, and the name (first and last) of the Department representative receiving and recording each proposal
- The Scope of Work from each solicited firm
- The evaluation ranking of the solicited firms
- Any other data or information that may be required or necessary to indicate compliance with this subsection

## **CHAPTER 9. LOCAL PUBLIC AGENCY CONTRACTS**

### **9.01 LPA Contract Monitoring**

The LPA contract monitoring shall provide sufficient oversight to ensure the federal-aid contracting process is carried out in accordance with all applicable laws, regulations and policies and include an evaluation of the contracting items submitted by the LPA for Department approval and filing in an LPA Monitoring File (Appendix 9.01). LPA Contracts with ODOT are authorized by Title 69 O.S. §§304, 507 and 601.

An LPA that submits a formal resolution proposing the use of federal funds for engineering or planning work on a non-highway (local city street or county road) under their jurisdiction shall have the right to select and employ the engineering or planning Consultant subject to compliance with State statutes, federal regulations and Department approval.

A Qualification Based Selection (QBS) process shall be used for the procurement of professional services. Experience with the QBS process is considered paramount. Therefore, an LPA's level of participation in the contracting process will vary depending on their QBS experience. The Department will only delegate a phase of the contracting process when the LPA demonstrates an ability to undertake and satisfactorily complete that phase of the contracting process. Until delegated, the Department will monitor and approve each phase of the process prior to the LPA proceeding to the next phase in the contracting process.

### **9.02 Solicitation Phase**

The LPA shall solicit the services of Consultants in a similar fashion as described in Chapter 3 or Chapter 8. The Department will provide the engineering contract number to the LPA. Upon request, the Department will furnish a list of Consultants from the Consultant database. The LPA may add to the list the names of other Consultants that have previously performed acceptable work on local city and county street or road projects. The LPA shall coordinate the DBE goal requirements with the Department's External Civil Rights Office for inclusion in the solicitation. Unless delegated, the Department must review and approve each solicitation prior to its issuance by the LPA (Appendix 9.02).

### **9.03 Selection Phase**

The LPA shall select the Consultant in a similar fashion as described in Chapter 4 or Chapter 8. The LPA shall seat a Selection Committee that consist of at least three (3) representatives which may include LPA staff, elected official and at least one member with technical expertise. The Department can serve as a resource for the Committee as a voting or non-voting member. Each proposed Committee member shall complete a Nondisclosure Statement for Evaluation Team form. The LPA shall provide the

Department the Nondisclosure Statement forms and the names and credentials of each of the members of the Selection Committee.

The Consultant selection shall be formalized by resolution. The LPA shall provide the Department the resolution and all the scoring documents prior to beginning the negotiations with the selected Consultant. The Department shall review the submitted information and unless delegated, provide notification (Appendix 9.03) to proceed to the contract development phase.

#### **9.04 Contract Development Phase**

The LPA shall initiate Contract negotiations with the top ranked Consultant as described in Chapter 5. The LPA will provide the Department all documentation associated with the final fee including the Consultant's overhead rate for use during any auditing actions.

The Consultant and LPA shall formally execute the contract and forward the executed Contract and resolution to the Department. The Department will not delegate the contract development phase and shall review LPA contract documentation for compliance prior to submitting to FHWA for execution. Following FHWA execution the Department will seek federal authorization and establish the Contact allotment prior to issuing the notice to proceed.

#### **9.05 Contract Administration Phase**

The LPA shall administer Consultant Contracts as described in Chapter 6. The LPA shall use their in-house staff to manage the Consultants. The LPA shall complete and submit to the Department a Consultant Evaluation for each Contract. The LPA shall notify the Department of any unsatisfactory performance by the Consultant. The Department will issue a stop work notification to the Consultant, if deemed appropriate, and any subsequent authorization to proceed.

The LPA shall serve a role similar to that identified as the Department's initiating division for any Task Orders associated with a Contract administered by the LPA.

The Consultant shall submit all claims for payment to the LPA for approval. The LPA shall submit all invoices regardless of whether the claim is approved or not to the Department for processing. The Department will process the LPA invoices in the customary fashion.

Supplements to LPA Contracts shall follow the same Contract Development process described in Section 6.07 considering the LPA allowances identified in Section 9.04.

The Department shall maintain the responsibility of closing the LPA Contract and shall maintain the LPA Contract documentation.

## **9.06 LPA Program Monitoring**

The LPA Program Monitoring includes continual program and process evaluation and a follow-up component that ensures the LPA maintains the appropriate level of expertise to administer the federal-aid contracting process. The Department will evaluate the results of the LPA contract monitoring and delegate (Appendix 9.06.01) a contracting phase to the LPA when that phase meets standards without revision. Delegated phases will continue to be monitored by the Department on an annual basis. The Department will renew the delegation if the results of the monitoring demonstrate that the LPA has remained in compliance (Appendix 9.06.02). Deficiencies found in delegated phases will result in the loss of such delegation (Appendix 9.06.03).

While the Department will offer any training, advice, or other assistance as may be needed by an LPA to aid it in successfully completing its federal-aid contract, it is understood that the process is controlled by the LPA. As such, the LPA shall be responsible to familiarize themselves with the Oklahoma Department of Transportation Guidelines for the Administration of Consultant Contracts. The Department's recourse for any LPA not following the prescribed requirements would be to remove federal-aid funds from the Contract.

## **9.07 Training**

The Department will evaluate the results of each phase of the contract monitoring plan to determine if specific training would be beneficial to the entities participating in the procurement of professional services. Each LPA with documented areas of needs improvement is required to send a representative to attend such training to be eligible to obtain delegation.



**OKLAHOMA DEPARTMENT OF TRANSPORTATION**  
**200 N.E. 21<sup>st</sup> Street**  
**Oklahoma City, OK 73105-3204**

---

**DATE:**

**TO: Project Management Division**

**FROM: Chief Engineer**

**SUBJECT: Justification for Professional Services Contract**

The Department's Chief Engineer or designee shall review and approve or disapprove the request for consultant services and notify the Project Management Division of the results.

The Divisions requesting consultant services on the current solicitation has ensured the full utilization of Department's staff and has justified the use of professional services.

Upon review of the current solicitation request, I concur the Department has met the considerations for utilizing external resources to meet the Department's mission, in-house capability was considered, the Department has committed adequate funding to complete the consultant contract, and the Department has adequate personnel available to monitor and manage the consultants compliance with the terms and conditions of the contract.

**CONCURRENCE:** \_\_\_\_\_

Chief Engineer

Date

## CONSULTANT DELIVERABLES

EC No. \_\_\_\_\_

County \_\_\_\_\_

Location \_\_\_\_\_

Services to be Performed	Services Performed By	
	ODOT	Consultant
<b>Corridor Study</b>		
Analysis/Recommendations of Alignments		
Additional Work:		
Comments:		
<b>Feasibility Study</b>		
Feasibility Report		
Functional Plans		
Additional Work:		
Comments:		
<b>Environmental Clearance</b>		
Aerials with Potential Impact Footprint		
Proposed Alignments		
Public Involvement		
Preparation of Document		
Additional Work:		
Comments:		
<b>Survey</b>		
Ground		
Aerial		
Additional Work:		
Comments:		
<b>Geotechnical</b>		
Pedological Survey		
FWD		
Soundings		
Additional Work:		
Comments:		



Services to be Performed	Services Performed By	
	ODOT	Consultant
<b>Roadway Design</b>		
Pavement Design		
Design Plans		
Additional Work:		
Comments:	Consultant will provide comparative estimates for pavement design.	
<b>Bridge Design</b>		
Hydraulic Analysis, Report & Conference		
Foundation Design & Conference		
Design Plans		
Additional Work:		
Comments:		
<b>Traffic</b>		
Operational Analysis		
Traffic Control		
Signing/Signals		
Additional Work:		
Comments:		
<b>Right-of-way</b>		
Construction Plans for Right-of-Way		
Additional Work:		
Comments:		

**Recommended Improvements:**

This project will consist of:

Construction Cost: \$

NBI Number(s):



Ray Sanders/ODOT  
01/28/2011 01:55 PM

To  
cc  
bcc

Subject Solicitation of Interest - Email Notification

**PLEASE READ THIS INFORMATION CAREFULLY AS THERE ARE NEW AND IMPORTANT ASPECTS THAT YOU MUST FAMILIARIZE YOURSELF WITH AND RESPOND TO IN YOUR LETTER OF INTEREST**

**NEW WEBPAGE INFORMATION:**

The Department continues the development of our internet capabilities as related to improving our consultant solicitation, communication and information systems. Once again, we would encourage you to update your bookmarks and check this page frequently for up to the minute information related to the Department's professional engineering services needs.

**Consultant Contract Information :**

<http://www.okladot.state.ok.us/projmgmt/contracts/index.htm>

**REQUESTED SERVICES:**

At this time, the Department is soliciting the services of consulting engineering companies to provide Preliminary Engineering and Construction Plans for a Grade, Draining, Bridge and Surface project in McCurtain County. These services require qualifications, expertise, experience and/or equipment that are of a highly specialized nature.

**NOTE: We no longer include electronic file attachments in the email notification. You can now find the documentation referenced in this email by using the provided webpage links.**

**Solicitation Package:**

<http://www.okladot.state.ok.us/projmgmt/contracts/SOLICITATION PACKAGE.pdf>

**ELECTRONIC SOLICITATION:**

The intent of this email is to provide all possible advance notification in order for you to begin your response preparations. This email is being forwarded to all Consultants who have properly responded to the Department's previous request for a useable email address. We will continue to make every attempt to provide this electronic version to everyone possible as fast as possible. This solicitation will no longer be provided by mail; however, if you have difficulty with the Consultant Information Webpage please advise and we can arrange to have it FAXED to you.

**NOTE: Only if there have been changes to the current information ODOT has on file for your firm will you need to complete the Professional Services Form and submit it to the Project Management Division.**

**Professional Services Form:**

<http://www.okladot.state.ok.us/projmgmt/contracts/pdfs/informationform.pdf>

**CONSULTANT QUALIFICATION:**

The Department no longer requires Consulting Firms to register through the Oklahoma Department of Central Services Construction and Properties Division as a condition of contract eligibility. The Department now accepts the CAP 255 as consideration for qualification of engineering firms to perform professional services for the Oklahoma Department of Transportation. The CAP 255 form should be included with the Letter of Interest Response Packet submitted for each solicitation. Qualifications will be determined specific to each contract.

**NOTE: Consultant firms performing professional services for the State of Oklahoma (NON-ODOT) must continue to register with the Oklahoma Department of Central Service.**

**CAP 255 Form:**

<http://www.okladot.state.ok.us/projmgmt/contracts/pdfs/cap255.pdf>

or select Microsoft Word format at:

<http://www.okladot.state.ok.us/projmgmt/contracts/index.htm>

**DISADVANTAGED BUSINESS ENTERPRISES (DBE):**

Please be advised that Disadvantaged Business Enterprises (DBE) participation in the Department's professional services contracts is always encouraged and supported. You can view the current Directory of Certified DBE Firms on the Department's website at:

<http://www.okladot.state.ok.us/dbeinfo/DCF.htm>

**DEADLINE:**

**The deadline for the submittal of your Response Packets will be 4:30 p.m. DATE.**

The Department anticipates the selection process to be complete and the contracts negotiated as soon as possible and no later than DATE for response packets 1 through ?. As all these contracts are anticipated to be financed with Federal Fiscal Year YEAR funding, the Notice to Proceed is expected as soon as possible and no later than DATE for response packets 1 through ?.

**LETTER OF INTEREST PACKET SUBMITTAL:**

**Option 1 – Electronic Submittal:**

Response packets can now be submitted electronically in a .pdf format to CA at:

**[CA@odot.org](mailto:CA@odot.org)**

**Option 2 – Ground Mail Submittal:**

If not sending electronically, please submit all packets to the following address:

**Project Management Division**

**Attn: CA**

**Room 1C-4A**

**Oklahoma Department of Transportation**

**200 NE 21st Street**

**Oklahoma City, OK 73105**

Thank you for your interest in providing services to the Department. If you have questions, comments or concerns, please feel free to call CA at (405) NUMBER.

**OKLAHOMA DEPARTMENT OF TRANSPORTATION**
**Project Management Division**
**200 N.E. 21<sup>st</sup> Street**
**Oklahoma City, OK 73105-3204**

Division Phone: (405) 522-7601

Division FAX: (405) 522-7612

**DATE:**
**TO: Consulting Engineering Companies**
**FROM: Ray Sanders, Project Management Division**
**SUBJECT: Solicitation of Interest**

At this time, the Department is soliciting the services of consulting engineering companies to provide Preliminary Engineering Services – Preparation of Construction Plans for projects identified by the ODOT within limits of the State of Oklahoma. These services require qualifications, expertise, experience and/or equipment that are of a highly specialized nature.

**Contact Person: PERSON - TELEPHONE NUMBER**

RESPONSE PACKET 1		
<b>Services Description:</b> Preliminary Engineering Services – Preparation of Construction Plans (Bridge and Approaches)		
<b>Contract No.</b>		PROJECT LOCATION  The anticipated services will include additional Survey, Geotechnical information, Preliminary and Final Design, Procurement of Right of Way, and Utility Relocation Coordination and will culminate in the submittal of Plans, Specifications and Estimates (PS&E).
<b>Expected Contracts</b>		
<b>ODOT Division</b>		
<b>County</b>		
<b>DBE Goal</b>		
<b>Construction JP No.</b>		

The Department solicitation of interest response mechanism is intended to reduce the reproduction requirements on work of a similar scope and/or specific to ODOT Field Divisions that will be reviewed by a common selection committee. Therefore, your response for the Professional Services Contract that you are interested in being considered for will include a total of one (1) response packet (one (1) unbound original) per common selection committee as described as follows:

**RESPONSE PACKET 1**

One (1) combined packet for EC No. including the following:

- A Letter of Interest referencing the Engineering Contract Number (EC No.)
- A Table of Organization depicting the proposed project team
- Any additional information you believe appropriate for the Department's use in determining your capabilities and qualifications to perform the type of work encompassed by that particular contract.

- A statement of your qualifications (CAP 255 Form preferred)
- A statement that identifies your firm's strategy in meeting the proposed DBE goal.
- FAR Audit or Audit Status Correspondence

**Please remember that this is a SOLICITATION OF INTEREST and not a Request for Proposal. As such, you are only requested to provide information related to your qualifications to perform the work described. Any additional information you choose to provide related to proposed solutions for the solicited projects or any other prepared Contract/Project specific media is NOT required and is unnecessary for the Department's processes. Proposals will be requested upon entering the interview phase of the Consultant Selection Process.**

The following factors will be considered primary for determining the firms that will be extended an invitation to interview and/or provide a proposal for Response Packet(s):

1. Experience and/or familiarity of the proposed Consultant Team with Department procedures.
2. Ability of the Consultant Team to perform the type of work contemplated.
3. Specialized qualifications of the Consultant Team applicable to the type of work contemplated.
4. Capacity of the Consultant Team to accomplish the work in accordance with the anticipated schedule considering current workloads.
5. Past performance of the Consultant Team (references may be requested if not provided).

**The deadline for the submittal of your Response Packet will be DATE at 4:30 p.m.**

The Department anticipates the selection process to be complete and the contract negotiated as soon as possible and as quick as DATE, due to the defined need to accelerate the replacement of the structure. This contract is anticipated to be financed with Federal Fiscal Year XXXX funding. The Notice to Proceed is expected as soon as possible and as quick as DATE.

**PLEASE NOTE: Response packets can now be submitted electronically in a .pdf format to CA at: [CA@odot.org](mailto:CA@odot.org)**

If not sending electronically, please submit all packets to the following address:

**Project Management Division  
Attn: CA  
Room 1C-4A  
Oklahoma Department of Transportation  
200 NE 21<sup>st</sup> Street  
Oklahoma City, OK 73105-3204**

As always, your assistance, cooperation and patience are greatly appreciated. Please do not hesitate to make us aware of any questions, comments or concerns that you may have or to offer suggestions for process improvement.



## OKLAHOMA DEPARTMENT OF TRANSPORTATION PROFESSIONAL SERVICES INFORMATION FORM

### COMPANY INFORMATION

#### MAILING ADDRESS

Company:

Address:

City:

State:

Zip:

#### COMPANY IDENTIFICATION

FEI #:

#### ESTIMATOR LICENSE INFORMATION

Serial No.

Expiration Date:

#### DISADVANTAGED BUSINESS ENTERPRISE

If your company is a DBE check type of DBE below:

- |   |   |  |
|---|---|--|
| <input type="checkbox"/> Black Male – BM      | <input type="checkbox"/> Native Male – NM           | <input type="checkbox"/> Asian Indian Male – AIM   |
| <input type="checkbox"/> Black Female – BF    | <input type="checkbox"/> Native Female – NF         | <input type="checkbox"/> Asian Indian Female - AIF |
| <input type="checkbox"/> Hispanic Male – HM   | <input type="checkbox"/> Asian Pacific Male – APM   | <input type="checkbox"/> White Female - WF         |
| <input type="checkbox"/> Hispanic Female - HF | <input type="checkbox"/> Asian Pacific Female - APF |  |

#### CONSULTANT SERVICES

Check each service your company provides:

- |  |   |  |
|--|---|--|
| <input type="checkbox"/> Aesthetics Study        | <input type="checkbox"/> County Bridge Inspection | <input type="checkbox"/> Railroad Services               |
| <input type="checkbox"/> Alignment Study         | <input type="checkbox"/> Environmental Study      | <input type="checkbox"/> Right-of-Way Plans              |
| <input type="checkbox"/> Architectural Design    | <input type="checkbox"/> Feasibility Study        | <input type="checkbox"/> Roadway Design                  |
| <input type="checkbox"/> Bridge Design           | <input type="checkbox"/> Fracture Critical        | <input type="checkbox"/> Signing, Signals, Illumin & ITS |
| <input type="checkbox"/> Bridge Inspection       | <input type="checkbox"/> Functional Plans         | <input type="checkbox"/> Survey                          |
| <input type="checkbox"/> Bridge Painting         | <input type="checkbox"/> Geo-tech – Bridge        | <input type="checkbox"/> Traffic Study                   |
| <input type="checkbox"/> Conceptual Plans        | <input type="checkbox"/> Geo-tech - Roadway       | <input type="checkbox"/> Underwater Bridge Inspection    |
| <input type="checkbox"/> Construction Inspection | <input type="checkbox"/> Hydrology/Hydraulics     |  |
| <input type="checkbox"/> Construction Management | <input type="checkbox"/> Operational Analysis     |  |

### COMPANY PERSONNEL

#### PRIME CONTACT PERSON

Contact Name

Phone No.

FAX No.

E-Mail

Receive Solicitation?

#### SECONDARY CONTACT PERSON(S)



**State of Oklahoma  
Department of Central Services  
Construction and Properties**

**INSTRUCTIONS FOR COMPLETING DCS-CAP FORM 255**

DCS-CAP Form 255 is the companion form to CAP Form 254 which permits Architects, Landscape Architects, Engineers and Land Surveyors to respond to invitations to be considered for design projects from the State of Oklahoma. It permits consultants to tailor their response to the specific project being considered by an agency.

This form is used in conjunction with DCS-CAP Form 254 in the same manner as Federal Standard Forms 254 and 255 are used for Federal selections. DCS-CAP Form 255 is to be used for a specific project and DCS-CAP Form 254 is used to be registered for consideration. **These forms have been designed to be as similar as possible to the Federal forms but SF254 and SF255 MAY NOT be used for State registration and selection.**

This form is divided into (6) break sections. To easily view where these sections occur, use the "View/Normal" command.

The first section contains a table, is unprotected, and allows for the first sheet/instructions to be deleted. The table can be deleted by selecting the whole table and using the "Edit/Cut" command.

The second section (Items 1 thru 5a) are protected and contains fields that can be filled in with the appropriate information.

The third and fourth sections (Item 6.) are unprotected and don't contain any fields. This allows for the whole table to be copied and pasted so that additional "Brief resumes..." can be input. The table can be copied by selecting the whole table and using the "Edit/Copy" And "Edit/Paste" commands.

The fifth and sixth sections (Items 7, 8, 9, 10) are protected and contain fields that can be filled in.

To better assist you in inputting information, you can turn on "Form Field Shading" and "Show Gridlines" using the forms toolbar.

Item 1. Enter the description of the project, as it appears in the letter you received announcing the project. If the agency has used a number to identify the project, include that number.

Item 2a. Enter the date of the letter announcing the project. You must reply to the agency as specified, to be considered. This completed form must accompany your letter of interest.

Item 2b. Enter the name of the agency from which you received the announcement letter.

Item 3. List the legal name and address of the firm or joint-venture submitting this form.

Item 3a. All firms, other than individuals practicing under their own license, or joint ventures must be certified by the Oklahoma Board of Registration for Professional Engineers and Land Surveyors or the Oklahoma Board of Governors for Licensed Architects and Landscape Architects.

Item 3b. Enter the firm's Tax ID Number.

Item 3c. Enter the name, title, and telephone number of the principal representing the firm or joint-venture submitting this form.

Item 3d. Enter the address of the office that will perform the work on this project, if it is different from that shown in item 3.

Item 4. List the number of personnel, by discipline, to be used on THIS PROJECT. List them only once by primary function. If functions are not shown, add them in the blanks provided.

Item 5. If a joint-venture is planned for this project, list the member firms and their respective areas of expertise here. All members must be registered with Construction and Properties. Provide total number of employees permanently employed by the firm listed. Do not include

employees of consultants or sub-consultants. A separate DCS-CAP Form 255 is required for additional consultants or sub-consultants.

Item 6. This page is for the resumes of the key personnel. It may be copied as necessary. It should be noted that Oklahoma law requires that design work for Oklahoma projects require the seals of architects and engineers licensed in the State of Oklahoma.

Item 7. This page is for the listing of projects accomplished by the (P)artnership, (C)orporation, (J)oint- (V)enture, or (I)ndividual, which best represents the qualifications of the firm for the type of project similar to the one announced. Do not include projects of consultants or sub-consultants.

Item 8. This area may be used to provide any other information not covered elsewhere on the form, which is pertinent to this project. List any special qualifications, which are applicable to this project.

Item 9. All prospective design consultants must be aware of the quoted section of law from Title 61 of the Oklahoma Statutes. The signature in Item 11 acknowledges that the excerpt has been read.

Item 10. A principal of the firm must sign and date the questionnaire for it to be accepted. Original signatures are required.

Return this completed form to the agency issuing the invitation with a letter requesting consideration for the proposed project.

 <p><b>STATE OF OKLAHOMA</b> Consultant Services For A Specific Project</p>	<p>1. Project Name/Location for which firm is filing:</p>	<p>2a. Date of Announcement:</p> <p>2b. Agency originating announcement:</p>		
<p>3. Firm (or Joint-Venture) Legal Name and Address:</p>		<p>3c. Name, Title, &amp; Telephone Number of Principal Contact:</p>		
<p>3a. Certificate of Authority Number:</p>		<p>3d. Address of office to perform work if different from Item 3:</p>		
<p>3b. FEI/Tax ID Number:</p>				
<p>4. Personnel by Discipline: (List each person only once, by primary function.)</p> <table style="width:100%; border: none;"> <tr> <td style="width:50%; border: none;">                 Administrative Architects CAD/CADD Technicians Chemical Engineers Civil Engineers Construction Inspectors Draftsmen Ecologists             </td> <td style="width:50%; border: none;">                 Economists Electrical Engineers Estimators Geologists Hydrologists Interior Designers Landscape Architects Land Surveyors Mechanical Engineers Mining Engineers Planners: Urban/Regional Sanitary Engineers Soil Engineers Specification Writers Structural Engineers Surveyors Total Personnel             </td> </tr> </table>			Administrative Architects CAD/CADD Technicians Chemical Engineers Civil Engineers Construction Inspectors Draftsmen Ecologists	Economists Electrical Engineers Estimators Geologists Hydrologists Interior Designers Landscape Architects Land Surveyors Mechanical Engineers Mining Engineers Planners: Urban/Regional Sanitary Engineers Soil Engineers Specification Writers Structural Engineers Surveyors Total Personnel
Administrative Architects CAD/CADD Technicians Chemical Engineers Civil Engineers Construction Inspectors Draftsmen Ecologists	Economists Electrical Engineers Estimators Geologists Hydrologists Interior Designers Landscape Architects Land Surveyors Mechanical Engineers Mining Engineers Planners: Urban/Regional Sanitary Engineers Soil Engineers Specification Writers Structural Engineers Surveyors Total Personnel			
<p>5. If submittal is by a JOINT-VENTURE, list participating firms and outline specific areas of responsibility (including administrative, technical and financial) for each firm: All firms and the joint venture MUST be registered with Construction and Properties, Department of Central Services, 2401 N. Lincoln Blvd., Suite 106, P. O. Box 53448, Oklahoma City, OK 73152-3448.</p>				
<p>5a. Has this Joint-Venture previously worked together? <input type="checkbox"/> Yes <input type="checkbox"/> No If YES, how many times? _____</p>				



6. Brief resume of key persons, specialists, and individual consultants employed by sub-consultants anticipated for THIS PROJECT.	
a. Name and Title:	
b. Project Assignment:	
c. Name of firm with which associated:	
d. Years experience: With this firm                      With other firms	
e. Education: Degree(s)/Year/Specialization	
f. Active Registration: State/Year first registered/Discipline/Oklahoma License Number Oklahoma Certificate of Authority (if any)	
g. Other experience and qualifications relevant to the proposed project:	

6. Brief resume of key persons, specialists, and individual consultants employed by sub-consultants anticipated for THIS PROJECT.	
a. Name and Title:	
b. Project Assignment:	
c. Name of firm with which associated:	
d. Years experience: With this firm      With other firms	
e. Education: Degree(s)/Year/Specialization	
f. Active Registration: State/Year first registered/Discipline/Oklahoma License Number Oklahoma Certificate of Authority (if any)	
g. Other experience and qualifications relevant to the proposed project:	

7. Work by firm or members which best illustrates current qualifications relevant to THIS PROJECT (list not more than 10 projects).

a. Project Name and Location	"P", "C", "JV" or "I"	b. Nature Of Firms Responsibility	c. Project Owner's Name and Address	d. Completion Date	e. Est. Cost (000's) Entire Project	Firm's Portion
1.						
2.						
3.						
4.						
5.						
6.						
7.						
8.						
9.						
10.						

8. Use this space to provide any additional information or description of resources (including any computer design capabilities) supporting your firm's qualifications for the proposed project.

9. 61 O.S., § 64. Offenses

Any consultant or person doing architectural, surveying or engineering work for the State of Oklahoma, their agents, servants or employees, who shall receive gratuity from any contractor or builder of any public building or works, or solicit, receive or make any political contribution from or to a contractor or a builder of any public building or works, or who attempts to interfere with the competitive bidding process of the State of Oklahoma in any manner, is guilty of a misdemeanor, and upon conviction thereof shall be fined not less than One Hundred Dollars (\$100.00) nor more than Five Hundred Dollars (\$500.00), and by imprisonment in the county jail for not less than six (6) months nor more than one (1) year. Any contractor or builder of any public building or works, their agents, servants or employees, who shall offer any gratuity or political contribution to any consultant doing architectural, surveying or engineering work for the State of Oklahoma, or who attempts to interfere with the competitive bidding process of the State of Oklahoma in any manner, is guilty of a misdemeanor, and upon conviction thereof shall be fined not less than One Hundred Dollars (\$100.00) nor more than Five Hundred Dollars (\$500.00), and by imprisonment in the county jail for not less than six (6) months nor more than one (1) year.

10. The foregoing is a statement of facts. My signature below indicates I have read the above excerpt from Title 61 of the Oklahoma Statutes.

Date: \_\_\_\_\_

Return this form along with your letter expressing interest to the agency from whom you received the notice of this project.

Signature: \_\_\_\_\_ Typed Name and Title: \_\_\_\_\_

OKLAHOMA DEPARTMENT OF TRANSPORTATION  
PROJECT MANAGEMENT DIVISION

**LETTERS OF INTEREST**

EC NO.

Due:

	CONSULTANT	DATE RECEIVED
1		
2		
3		
4		
5		
6		
7		
8		
9		
10		
11		
12		
13		
14		



**OKLAHOMA DEPARTMENT OF TRANSPORTATION**  
**200 N.E. 21<sup>st</sup> Street**  
**Oklahoma City, OK 73105-3204**

---

**DATE:**

**TO: Director**

**FROM: Assistant Chief Engineer**

**SUBJECT: Consultant Selection Committee**

The personnel referenced below have been tentatively chosen to serve on the consultant selection committee for the \_\_\_\_\_ solicitation.

**EC-\_\_\_\_\_ – Contract Description – Response Packet 1**

Name	Division	Chair
Name	Division	Member
Name	Division	Member

The committee(s) will review all available information on the interested firms and conduct the interviews and make recommendations as to the most qualified applicant.

With your approval, the interview phase of this service is expected to commence in this fiscal year.

Your approval is respectfully requested. If you have questions or comments, please feel free to call on me at your convenience.

**RECOMMENDED:** \_\_\_\_\_  
 Assistant Chief Engineer Date

**CONCURRENCE:** \_\_\_\_\_  
 Chief Engineer Date

**APPROVED:** \_\_\_\_\_  
 Director Date



**OKLAHOMA DEPARTMENT OF TRANSPORTATION**  
200 N.E. 21<sup>st</sup> Street  
Oklahoma City, OK 73105-3204

---

### **Nondisclosure Statement for Evaluation Team**

#### **Instructions**

This form is to be completed by all Evaluation Team Members when deemed necessary. All statements should be maintained in the contract file.

**EC Number** \_\_\_\_\_

I hereby certify that I will not disclose or release any confidential information prior to award of the contract. Confidential information includes, but is not limited to, the contents of all proposals submitted in response to the referenced Engineering Contract and any analysis or evaluation thereof. I agree to disclose to the Director of Transportation or designee all contacts I have had with the below listed consultants. I agree to disqualify myself from participation in the evaluation team should the Director of Transportation or designee find any of said contacts that may be perceived as compromising my independent judgment in the evaluation process. I further agree and understand that failure to abide by the terms of this statement may subject me to other adverse actions.

#### **List of Consultants for Evaluation**

- |           |           |
|-----------|-----------|
| 1. _____  | 2. _____  |
| 3. _____  | 4. _____  |
| 5. _____  | 6. _____  |
| 7. _____  | 8. _____  |
| 9. _____  | 10. _____ |
| 11. _____ | 12. _____ |

Describe all current personal, business and/or government relationships between yourself or your family members and any of the consultants listed above. Include in your comments, the name of the consultant and a brief description of the nature of the relationship.

\_\_\_\_\_  
Evaluator Signature

\_\_\_\_\_  
Date

\_\_\_\_\_  
Printed Name

\_\_\_\_\_  
Printed Title









**OKLAHOMA DEPARTMENT OF TRANSPORTATION**  
**200 N.E. 21<sup>st</sup> Street**  
**Oklahoma City, OK 73105-3204**

---

**DATE:**

**TO: Chief Engineer**

**FROM: Contract Administrator**

**SUBJECT: Short-list Approval**

The Selection Committee has completed their short-listing evaluations for EC-\_\_\_\_\_ and respectfully recommends that \_\_\_\_ ( ) Consulting Firms be selected to interview for the \_\_\_\_\_ contract. The following are the Consulting Firms recommended to be interviewed for the referenced contract:

Consulting Firm	Firm's Location

These recommendations are based on the Consultant's ability to provide the services required for this project. The recommendation of the shortlist by the committee is hereby submitted for your approval.

**CONCURRENCE:** \_\_\_\_\_  
 Assistant Chief Engineer Date

**APPROVAL:** \_\_\_\_\_  
 Chief Engineer Date



**OKLAHOMA DEPARTMENT OF TRANSPORTATION**  
**200 N.E. 21<sup>st</sup> Street**  
**Oklahoma City, OK 73105-3204**

---

Date

Consultant Names  
Address  
City

RE: EC-\_\_\_\_\_ – Description of Contract

To whom it may concern:

On behalf of the Department of Transportation, thank you for your interest regarding the \_\_\_\_\_ services for the above referenced contract.

The selection committee has completed the consultant reviews and has determined a short list for the interviews. The Department has chosen to utilize another firm for this contract. There will be additional contracts in the future and we look forward to hearing from your firm regarding those contracts.

Please contact this office if you have any questions or require additional information.

Sincerely,

Contract Administrator

c: Consultant Selection Committee



**OKLAHOMA DEPARTMENT OF TRANSPORTATION**  
**200 N.E. 21<sup>st</sup> Street**  
**Oklahoma City, OK 73105-3204**

---

Date

Consultant Name  
Address  
City

\_\_\_\_\_:

Your Firm has been selected to interview for EC – \_\_\_\_\_ – Description of Contract

The interviews will be held in the \_\_\_\_\_ conference room (\_\_\_\_), located \_\_\_\_\_ . Your Firm's presentation is scheduled for Month, Day, Year at \_\_\_\_.

The presentation is to be a maximum of 15 minutes, followed by a 15 minute question and answer period. The following topics should be addressed during the presentation:

1. Consultant's project management approach for this contract or project.
2. Ability of the Consultant Team to ensure compliance with scope limitations and scheduled milestones.
3. Ability to stay within budgetary constraints of the project.
4. Proposed design approach, staffing commitment, and solution(s) for this contact demonstrating an understanding of the contract requirements.
5. Initiative and innovation as demonstrated by the introduction of unique concepts.

Should you have any questions or comments, please contact me at 405-\_\_\_\_ - \_\_\_\_.

Sincerely,

Contract Administrator

c: Consultant Selection Committee







**OKLAHOMA DEPARTMENT OF TRANSPORTATION**  
**200 N.E. 21<sup>st</sup> Street**  
**Oklahoma City, OK 73105-3204**

---

**DATE:**

**TO: Director**

**FROM: Contract Administrator**

**SUBJECT: Consulting Firm Selection: for EC-\_\_\_\_\_ - Contract Description**

The selection committee interviewed \_\_\_\_ (\_\_) consulting firms regarding the Engineering Contract to provide \_\_\_\_\_ in support of the Oklahoma Department of Transportation Staff. The committee has completed their interviews and provided a recommendation for the selection of \_\_\_\_\_ (\_\_) consulting firm to provide this service.

After a review of all available information and presentations, the following Consulting Engineering Firm was selected:

SELECTED CONSULTANT	LOCATION

This recommendation is based on each consultant's previous and existing work in the areas of expertise needed to perform the engineering services.

Your approval is respectfully requested. If you have questions or comments, please feel free to call on me at your convenience.

RECOMMENDED: \_\_\_\_\_  
 Assistant Chief Engineer Date

CONCURRENCE: \_\_\_\_\_  
 Chief Engineer Date

APPROVAL: \_\_\_\_\_  
 Director Date



**OKLAHOMA DEPARTMENT OF TRANSPORTATION**  
**200 N.E. 21<sup>st</sup> Street**  
**Oklahoma City, OK 73105-3204**

---

Date

Consultant Name  
Address  
City

The Selection Committee has completed their evaluations of EC-\_\_\_\_ - Contract Description, and has selected your firm to perform the services for the referenced contract.

The Department targets this contract for approval at the \_\_\_\_\_ regular meeting of the Oklahoma Transportation Commission. We request you prepare a draft scope of work that demonstrates your knowledge of the project requirements. Please submit all information by \_\_\_\_\_ to the Project Management Division, Room 1C-4A, Attn.: \_\_\_\_\_, Oklahoma Department of Transportation, 200 N.E. 21<sup>st</sup> Street, Oklahoma City, Oklahoma 73105-3204. A negotiation meeting will be scheduled at a later date.

We appreciate your interest and commitment in support of Oklahoma's transportation program. Should you have any questions or comments, please contact \_\_\_\_\_ of the Project Management Division, (405) \_\_\_\_ - \_\_\_\_\_, for further assistance.

Sincerely,

Contract Administrator

c:     Consultant Selection Committee





**OKLAHOMA DEPARTMENT OF TRANSPORTATION**  
**200 N.E. 21<sup>st</sup> Street**  
**Oklahoma City, OK 73105-3204**

---

Date

Consultant Name  
Address  
City

RE: EC-\_\_\_\_\_ - Contract Description

\_\_\_\_\_:

On behalf of the Department of Transportation Selection Committee, I want to thank you for your interest and interview for the \_\_\_\_\_ contract, EC-\_\_\_\_\_ - Contract Description, in support of ODOT staff. The Department has chosen to utilize another firm for this contract.

The Department of Transportation wishes to express their appreciation for your interest and commitment in support of Oklahoma's Transportation program. There will be additional contracts in the future and we look forward to hearing from you regarding those contracts.

If you have any questions or comments, please contact me at the number listed below.

Sincerely,

Contract Administrator

c: Consultant Selection Committee

**STATE OF OKLAHOMA  
DEPARTMENT OF TRANSPORTATION  
ENGINEERING CONTRACT NO. EC-  
PRELIMINARY ENGINEERING PROJECT NO.  
JOB PIECE NO.  
COUNTY**

This Contract is entered into between the Department of Transportation, hereinafter called the Department, acting for and on behalf of the State of Oklahoma, under the authority vested in the Transportation Commission by the provisions of 69 O.S., Section 708.2 and [REDACTED], hereinafter called the Consultant, for the purpose of the Department acquiring the professional services of the Consultant for the following work; to wit:

The Consultant shall, except as may be otherwise specifically provided for herein, furnish all professional services, labor, equipment and incidentals as required for this Contract.

**WITNESSETH:**

**WHEREAS**, the Department is charged under the laws of the State of Oklahoma with the design, construction and maintenance of state highways; and,

**WHEREAS**, the Department, as part of fulfilling its responsibilities, may enter into contracts with private firms for professional services related to the transportation industry in the State of Oklahoma; and,

**WHEREAS**, an increase in the Department's Transportation program has caused a reduction in the Department staff's ability to provide construction support, management and oversight services, such that it is desirable for the Department to enter into a contract with the Consultant to provide the Department's required activities; and,

**WHEREAS** the Department is authorized under the provisions of Title 69 O.S., Section 708.2 to contract for necessary services; and,

**WHEREAS**, after due consideration of professional consulting firm proposals and interview results, the Department has selected the Consultant as a qualified consulting firm to perform professional services; and,

**WHEREAS**, the Consultant has employees who have the training, experience and all necessary qualifications to provide professional services; and,

**WHEREAS**, the Consultant will make their employees available to provide professional services and has agreed with the Department as to the terms and conditions under which the Consultant can perform such services;

**NOW THEREFORE**, for and in consideration of the mutual covenants contained herein, the Department and the Consultant do hereby mutually promise and agree as follows:

**SECTION 1. PURPOSE OF THE CONTRACT**

- 1.1. The Department does hereby engage and retain the Consultant as an independent contractor to furnish professional engineering services to supplement the Department's workforce. The purpose of this Contract is to establish terms and conditions required for the performance of said services.
- 1.2. All services authorized by this Contract or modifications to this Contract and as further specifically defined by the Scope of Services in accordance with Exhibit "A" and all Attachments thereto and subsequently approved by the Department are to be provided under the explicit terms and conditions of this Contract. Under this Contract, the Department and the Consultant agree that.
  - 1.2.1. The Consultant will make all necessary investigations and prepare detailed final design plans as specifically set forth in the foregoing project description and the special contract requirements included in Exhibit "A", and all Attachments which are attached hereto and made a part hereof. The design and plans shall conform to current State and AASHTO policies and standards, as modified by the Department, including but not limited to:
    - 1.2.1.1. "A Policy on Design Standards-Interstate System", AASHTO, January 2005 (latest revision)
    - 1.2.1.2. "Manual on Uniform Traffic Control Devices for Streets and Highways", U.S. Department of Transportation, FHWA, 2009, as amended (latest revision)
    - 1.2.1.3. "An informational Guide for Roadway Lighting", AASHTO, 1985 (latest revision)
    - 1.2.1.4. "LRFD Bridge Design Specifications for Highway Bridges", AASHTO, 2007, and all current interim specifications
    - 1.2.1.5. "ANSI/AASHTO/AWS D1.5 Bridge Welding Code", 2008, and all current interim
    - 1.2.1.6. "A Policy on Geometric Design of Highways and Streets", AASHTO, 2004 (latest revision)

## APPENDIX 5

- 1.2.1.7. Oklahoma Department of Transportation Standard Specification for Highway Construction, and Supplements”, 2009 (latest revision)
  - 1.2.1.8. “Highway Capacity Manual, Transportation Research Board”, 2007 (latest revision)
  - 1.2.1.9. “Policy on Driveway Regulations for Oklahoma Highways”, 1996 (latest revision)
  - 1.2.1.10. “Roadside Design Guide”, AASHTO, 2006 (latest revision)
  - 1.2.1.11. “ODOT Right-of-Way Specifications Manual for Preparation of Plans and Documents” (latest revision)
  - 1.2.1.12. “Oklahoma Department of Transportation’s Office of Land Acquisitions Policy and Procedures Manual” (Latest revision).
  - 1.2.1.13. “Value Engineering” ODOT Policy Directive No. D-601-1
  - 1.2.1.14. “Oklahoma Administrative Code, Title 730”
  - 1.2.1.15. “Oklahoma Department of Transportation Roadway Design Manual”, 1992 (latest revision)
  - 1.2.1.16. “Specifications For Surveys For Primary and Secondary Highways” (latest revision)
  - 1.2.1.17. “Aerial Mapping Specifications”
  - 1.2.1.18. Aerial Photography Specifications”
  - 1.2.1.19. “LiDAR Mapping Specifications”
  - 1.2.1.20. “CADD Standards”
  - 1.2.1.21. Geotechnical Specifications for Roadway Design Division, 2011 (latest revision).
  - 1.2.1.22. Specifications for the Geotechnical Investigation of Bridges and Related Structures, 2005 (latest revision)
- 1.3. The Consultant will, as directed by the Department and as further defined by the Scope of Work, provide all labor, equipment, materials, supplies, and incidentals

to accomplish all activities. These activities and services may include, but will not be limited to survey responsibilities, geotechnical studies, grading, drainage, surfacing, bridges, retaining walls and right-of-way plans, all as further defined in Exhibit "A" and Attachments which are attached hereto and incorporated herewith.

- 1.4. The Department reserves the right to determine the schedule, precedence, scope, limits, and sequence for any assigned projects and services. The Department may elect to complete the project or any part thereof using its own forces or the services of others.

## **SECTION 2. GENERAL PERFORMANCE REQUIREMENTS**

- 2.1. The Consultant agrees to the following as appropriate and when applicable to the Scope of Services of this Contract:
  - 2.1.1. To compute and place upon the roadway and bridge construction plans and right-of-way ties to the survey line for the purpose of staking the right-of-way line for construction operations. This requirement shall apply whether the right-of-way plans are a part of this Contract or prepared by the Department.
  - 2.1.2. To prepare and furnish complete detailed final construction plans as called for in the project description. These plans shall be prepared in accordance with the Department's "Specifications for Detailed Construction Plans for Grading, Drainage, Surfacing, Structures, and Incidentals" and pertinent special provisions and specifications included as part of Exhibit "A", Attachment A6.
  - 2.1.3. To prepare and furnish complete detailed bridge construction plans as well as bound and checked structural design, hydraulic, geometric, and pay quantity computations when called for in the project description. These plans and computations shall be prepared in accordance with the Department's "LRFD Bridge Design Specifications for Highway Bridges" and pertinent special provisions and specifications included as part of Exhibit "A", Attachment A7.
  - 2.1.4. To prepare and furnish the geometric design for required interchanges in accordance with current design policies.
  - 2.1.5. To prepare and furnish all field surveys and mapping in accordance with the Department's Survey Division "Specifications for Surveys for Primary and Secondary Highways", "Aerial Photography Specifications" and "Aerial Mapping Specifications", CADD Standards, and pertinent special provisions and specifications included as part of Exhibit "A", when called for in the project description.

- 2.1.6. To prepare and furnish complete structural design, hydraulic (including drainage maps and design data for any storm sewer systems and other drainage included in this Contract), geometric and pay quantity computations, when called for in the project description.
- 2.1.7. The Consultant shall ensure that these computations are independently checked in detail by competent personnel and shall provide a written statement to that effect when the plans are submitted.
- 2.1.8. All computations shall be neat, legible, identified, indexed and bound in a manner that is easy to follow by someone unfamiliar with the project. They shall be considered a part of the work done under this Contract and shall become the sole property of the Department.
- 2.1.9. To furnish comparative estimates for the alternates required in the pavement design process. The Department will provide the pavement design and supply the alternatives to the Consultant.
- 2.1.10. To furnish any additional plan sheets as required by the Department.
- 2.1.11. All electronic documents shall be in a deliverable electronic format which meets the guidelines of the Oklahoma HB-2197 (O.S. 62 § 41.5e) to ensure compliance with the Americans with Disability Act (ADA).
- 2.1.12. That all preliminary designs, final plans and reports submitted for review by the Department shall be accompanied by a written statement signed and sealed by a professional engineer attesting that a prior detailed check has been made of the plans and reports.
- 2.1.13. Federal funds are authorized only for preliminary design activities. No final design activities will begin until such time that the environmental document is completed and approved by the Federal Highway Administration and that a specific notice to proceed with final design activities is received from the Department. If the proposed scope of services of this Contract is substantially altered based on the outcome of NEPA, any associated modifications will be reduced to writing and agreed to by the Consultant and the Department. In the event that such modifications are determined to warrant a written amendment to this Contract, the modifications will be addressed in accordance with Section 6 of this Contract.
- 2.1.14. To prepare a complete detailed environmental clearance document as called for in the project description. This document shall be prepared in

accordance with the Department's current design policies and pertinent special provisions and specifications included as part of Exhibit "A".

- 2.1.15. To prepare the right-of-way studies, legal descriptions and instruments of conveyance for total take parcels in accordance with the "Right-of-Way Specifications Manual and Associated Materials".
- 2.1.16. To provide public involvement participation, coordination and the necessary support between the Department, the effected Cities, local business owners, residents and community based organizations. Such services shall include, but not be limited to, attendance and participation at meetings, gatherings, assemblies or hearings as requested by the Department.
- 2.1.17. To be available for such conferences as the Department may deem necessary in connection with the work. The Department shall have the right to inspect the work at all reasonable times at an acceptable working office located at .
- 2.1.18. To coordinate its engineering work with other Consultant's on adjoining projects, if any, and to furnish and share survey and plan data in such a manner as to facilitate and expedite the completion of contracts for adjacent engineering work.
- 2.1.19. To furnish a legible copy of all computations used in developing cost estimates which are neatly arranged, bound and are properly identified and indexed. The computations shall be submitted when the documents are submitted to the Department. The Consultant shall furnish drainage maps and design data with computations for any storm sewer systems and other drainage involved in this Contract.
- 2.1.20. To furnish monthly reports to the Department showing the progress of the work. These monthly reports shall be prepared in accordance with the requirements of the Department's "Baseline Schedule/Cost Estimates" special provisions and specifications included as part of Exhibit "A", Attachment A2. In the event of any delay in performing the work and/or increase in anticipated construction costs of the resulting project provided for in this Contract, the Consultant shall immediately notify the Department and shall fully explain the nature, time, and reason for the delay.

### **SECTION 3. TIME FOR PERFORMANCE**

- 3.1. Time is considered of the essence in the performance of the services required by this Contract and defined in the scope of work.

- 3.2. The Consultant will be prepared to commence work upon receiving a Notice to Proceed from the Department and to complete all functions in accordance with the schedule and delivery requirements outlined in the "Baseline Schedule / Cost Estimates" special provisions and specifications included as part of Exhibit "A", Attachment A2.

#### **SECTION 4. COMPENSATION**

- 4.1. The total compensation due to the Consultant for services under this Contract will be a function of the cumulative total fees earned as provided in the "Schedule of Progressive Payments" listed and included as a part of Exhibit "A", Attachment A3.
- 4.2. Compensation for services rendered under this Engineering Contract will be a maximum not to exceed amount of            Dollars (\$            ).
  - 4.2.1. This total is subject to adjustment only in the event of a substantial change in the character or scope of the work; as provided in Section 6, Changes and Modifications.
  - 4.2.2. Partial payment for specifically defined and/or Task ordered services to be compensated as "lump sum" will be made progressively in accordance with the "Schedule of Progressive Payments" listed and included as a part of Exhibit "A", Attachment A3.
  - 4.2.3. The method for determining compensation will be lump sum, cost plus fixed fee, hourly rates, or cost per unit of work as negotiated and defined below:
    - 4.2.3.1. "Lump Sum" will be the total compensation paid to the Consultant for services rendered. The Lump sum will include all cost to the Consultant including labor, overhead, material, travel, Sub-Consultant administrative fees on professional services sub-contracted to others, and other costs in the conduct of the work. Unless the scope of work changes, the Consultant will not be entitled to additional compensation.
    - 4.2.3.2. The "cost plus fixed fee" method of compensation will use the actual costs incurred by the Consultant, including salaries, overhead and other direct expenses with a fixed amount of fee to be paid upon completion of the project. The Consultant and the Department will negotiate the fixed fee and the not to exceed amount. Unless the scope of work changes, the Consultant will not be entitled to additional compensation.



- 4.2.3.3. The “hourly rate” method will use fixed hourly rates and direct expenses provided in Exhibit “A”, Attachment B3 – Approved Hourly and Overhead Rates. Hourly rates will be based on salary cost, overhead as derived from the associated schedules and a reasonable fee as approved by the Department. The hourly rates established will be considered provisional and will remain subject to adjustment until the completion and evaluation of a Department audit of the Consultant’s Indirect Cost Rates. The Consultant and the Department will negotiate the not to exceed amount to be accomplished, on estimated man-hours per task, Sub-Consultant costs, administrative fees on professional services sub-contracted to others, and direct expenses required to accomplish the scope of work.
- 4.2.3.4. The “cost per unit of work” method will be used when a task is clearly defined and a unit price can be established. Unless the units of work change, the Consultant will not be entitled to additional compensation under a task order using the “cost per unit of work” method of compensation.

## **SECTION 5. METHOD OF PAYMENT**

- 5.1. The Consultant will provide supporting information and an invoice for specifically defined services to be compensated as “lump sum” by the tenth (10<sup>th</sup>) working day of each month, no later than one (1) month in arrears. Invoices will be prepared utilizing the forms and/or in the format required by the Department. Incomplete or inaccurate invoices will delay the payment of claims; therefore, the Consultant will check and review invoices carefully to assure each is complete and accurate prior to submittal to the Department.
- 5.2. In no case will the Consultant invoice the Department any amount which exceeds the compensation limits of the partial payment amounts for specifically defined services to be compensated as “lump sum”.
- 5.3. Partial payments made for services provided to the Department during the course of this Contract shall be considered interim payments and shall be subject to audit review and recalculation upon completion of work required by this Contract. Upon completion of audit of project records a final invoice shall be prepared and Consultant shall receive final payment subject to any necessary audit adjustments. Interim payment invoices shall be signed by a Corporate Officer or Principal which shall without other certification be sufficient. Signatures may be by electronic means if allowed by Department procedures.

- 5.4. The certification form contained in Attachment H shall be completed and submitted at the time the final invoice is submitted to the Department for payment.

## **SECTION 6. CHANGES AND MODIFICATIONS**

- 6.1. The terms of this Contract may be modified by written amendment if the Department determines that there is a significant change in 1) the scope, complexity, or character of work related to this Contract, or 2) the schedule for performing the work, or 3) the compensation due the Consultant.
- 6.2. In the event the Department requests, in writing, revisions in the character or scope of the work or modifications to work completed under this Contract, a Supplemental Agreement to this Contract shall be negotiated and approved in writing prior to the Consultant performing the changed work.
- 6.3. If the Department finds it necessary to request changes to previously satisfactorily completed work or parts thereof which involve changes to the original scope of services or character of work under this Contract, the Consultant will make such revisions if requested and as directed by the Department. Such changes will be authorized under an approved Supplemental Agreement to this Contract.
- 6.4. Charges for extra work performed or materials furnished will not be invoiced or included in a claim by the Consultant until execution of the Supplemental Agreement to this Contract encompassing such extra work or services.
- 6.5. Changes or modifications will not be binding unless and until approved and executed in writing by the Consultant and Department in accordance with this Section.

## **SECTION 7. MUTUAL AGREEMENTS**

- 7.1. The Department and the Consultant mutually agree:
  - 7.1.1. That the services to be performed by the Consultant shall include and encompass those services identified in Exhibit "A", Attachment A1, Scope of Services, which is attached hereto and incorporated herewith.
  - 7.1.2. That the Consultant shall hold the Department as a confidential client. The Consultant shall make no statements or publish any materials regarding any investigations to any party on behalf of the Department without prior written authorization from the Department. The Consultant

shall refer all questions regarding this Contract and the work defined herein to the Department.

- 7.1.3. That because the Consultant has no control over the cost of labor, materials, or equipment furnished by others, the Consultant's opinion of probable construction costs shall be made on the basis of its experience and qualifications as a professional engineer. The Consultant does not guarantee that proposals, bids, or actual project construction costs will not vary from the Consultant's construction cost estimates.
- 7.1.4. That the Department will furnish the termini for each construction project and the Consultant will furnish a complete set of construction plan tracings and the necessary specifications for each project. The project plans shall be prepared in sequence as directed by the Department.
- 7.1.5. That when the plans are completed to the field review stage, representatives of the Department will accompany the Consultant on a field review investigation to mutually determine design features to be incorporated in the final plans.
- 7.1.6. That in the event the Department orders in writing any major revision in the character or scope of the design work after a substantial amount of work on the plans has been completed, a Supplemental Agreement shall be negotiated prior to the Consultant performing the additional work in accordance with Section 6.
- 7.1.7. That when the preparation of plans for bridges is a part of this Contract, it is understood that the exact bridge locations and type of bridge structures are tentative. It will be the decision of the Department following the field review as to the exact location of the bridges and structure type to be designed. The parties may negotiate an adjustment in the fee if justified by any significant increases or decreases in the work to be performed.
- 7.1.8. That all tracings, plans, computations, specifications, and maps prepared or obtained under the terms of the Contract shall be delivered to and become the property of the Department. All basic survey notes and sketches, charts, computations, and other data prepared or obtained under this Contract shall be made available upon request to the Department without restriction or limitation on their use. When a Contract is for preliminary plans only, no commitment is made or implied that would constitute a limitation on the subsequent use of the plans or the ideas incorporated therein for preparation of construction plans.

- 7.1.9. That the Consultant shall furnish all engineering services, labor, equipment, and incidentals as may be required to perform this Contract, except as may be otherwise specifically provided for herein.
- 7.1.10. That the Consultant shall sign the final product of the Consultant's efforts submitted to the Department and affix the appropriate Oklahoma seal as proof of Professional Engineer registration in the State of Oklahoma.
- 7.1.11. That the Consultant will abide by the applicable schedule of performance outlined below:
  - 7.1.11.1. Make hydraulic studies as required by pertinent special provisions included as part of Exhibit "A". The Department will conduct a Hydraulic Conference with the Consultant on Hydrology and Hydraulic Design.
  - 7.1.11.2. Prepare and submit fourteen (14) sets of black and white prints of the preliminary construction plans for use at the Preliminary Plan Field Review Meeting (13 half-size and 1 full-size).
  - 7.1.11.3. Attend the field reviews with representatives of the Department for determination of specific bridge locations and structure type.
  - 7.1.11.4. Within ten (10) days after the Preliminary Plan Field Review Meeting and mutual agreement as to design features, the Consultant shall submit a written report concerning the Preliminary Plan Field Review Meeting to the Department and provide a cost estimate for construction due to the changes.
  - 7.1.11.5. Make all engineering estimates that are necessary to determine the most economical and desirable structures in accordance with Department Policy.
  - 7.1.11.6. When the Department has determined the pavement type and thickness of the various component parts of the project, the Consultant will prepare and submit for approval, three (3) sets of prints of the proposed typical sections as well as comparative estimates for submittal with the pavement design packet.

- 7.1.11.7. The Department will conduct a foundation conference with the Consultant on substructure design after sounding logs have been received by the Consultant.
- 7.1.11.8. Prior to the Right-of-Way submission, a meeting must be held between the Consultant, Design and Right-of-Way personnel. The Consultant shall submit sixteen (16) sets of black and white preliminary construction plans (fourteen (14) half-size, five (5) of which have cross sections and two (2) full-size, one (1) of which have cross sections).
- 7.1.11.9. At the time of Right-of-Way submission, provide six (6) full -size sets of black and white plans, two (2) full-size set of black and white cross sections, seven (7) half-size sets of black and white plans, four (4) half-size sets of black and white cross sections, two (2) CD-ROM including all electronic files of the construction plans. (The complete set of on Windows® Compatible CD(s) with complete CADD design files in Microstation® format, current ODOT-Roadway Design version, with accompanying InRoads® Alignments(.alg), Surface(.dtm) and Adobe PDF). All plans should be stamped "Proposed R/W" and dated accordingly.
- 7.1.11.10. Prepare and submit eleven (11) half-size sets of black and white prints of the preliminary construction plans, six (6) of which contain cross sections for use at the Final Plan Field Review Meeting.
- 7.1.11.11. Within ten (10) days after the Final Plan Field Review Meeting and mutual agreement as to design features, the Consultant shall submit a written report concerning the Final Plan Field Review Meeting to the Department and provide a cost estimate for construction due to the changes.
- 7.1.11.12. Complete final plans incorporation data developed during the Final Plan Field Review Meeting and in accordance with agreements reached in consultation with the Department. If United States Army Corps of Engineers and/or United States Coast Guard permits are required for the project, Consultant shall cooperate and furnish necessary data and sketches, in a timely manner, to enable the Department to promptly pursue the steps required to obtain these permits.

- 7.1.11.13. Submit, for review by the Department, completed final roadway construction plans accompanied by the Consultant's certification of accuracy and the documentary data required in accordance with Section 2.
- 7.1.11.14. Submit complete final bridge plans with two (2) sets of bound structural design computations to the Department for review.
- 7.1.11.15. Make necessary corrections and submit the final plans to the Department.

**SECTION 8. EMPLOYMENT OF FORMER DEPARTMENT OF TRANSPORTATION EMPLOYEES – ETHICS**

- 8.1. Title 74 OS §85.42 provides that neither the Consultant nor any Sub-Consultant may employ on a full time or part time basis any person who participated in the development or consultant selection for this Contract if that person has within the preceding year been an employee of the Department. For any violation of this Section, the Department, at its sole discretion, shall have the right to terminate this Contract and/or any approved task order without liability and/or withhold future engineering contacts or task orders from Consultant or Sub-Consultant. Consultants who are former Department employees and who have retired from State service should be aware of the provisions of Title 74 OS §914 and QAC Section 590:10-7-18 and the fact that resumption of State service may result in temporary cessation of retirement benefits or participation in the Oklahoma Public Employees Retirement System.
- 8.2. The Consultant will familiarize itself with the rules and regulations promulgated by the Oklahoma Ethics Commission (Oklahoma Administrative Code Title 257, Chapters 20 and 23). Any violation of these regulations by the Consultant will be grounds for immediate termination of this Contract and without further compensation from the Department. Any violation of this provision by an employee of the Department shall immediately be reported, in writing, by the Consultant to the Department.

**SECTION 9. ADVERSE OR PECUNIARY INTEREST**

- 9.1. The Consultant, principals and Sub-Consultants, suppliers, licensees or agents of the Consultant and their employees that possess ownership interests will be bound by the provisions of Title 69 O.S. § 310 and all other state and federal laws and statutes relating to adverse or pecuniary interests or conflicts of interest.

**SECTION 10. GOVERNING LAWS AND REGULATIONS**

- 10.1. This Contract shall be governed and construed in accordance with the laws of the State of Oklahoma and the applicable rules, regulations, policies, and procedures of the Oklahoma Transportation Commission. Venue for any action to construe or have enforced any provision of this Contract shall be in the District Court of Oklahoma County, State of Oklahoma.

## **SECTION 11. DISPUTE RESOLUTION**

- 11.1. The parties hereto have entered into this Contract in the State of Oklahoma and the laws of the State of Oklahoma shall apply. The parties agree to bargain in good faith in direct negotiation to achieve resolutions of any dispute and, if such efforts are unsuccessful, to retain a neutral mediation service to mediate the dispute prior to filing court action. Mediation shall be conducted in the Oklahoma City area and the costs of such mediation shall be borne equally by the parties. If mediation is not successful, venue for any action brought to enforce the terms of this Contract shall be Oklahoma County, State of Oklahoma. Each party shall bear any costs and attorney fees incurred by that party in such litigation.

## **SECTION 12. TERMINATION AND DEFAULT**

- 12.1. Upon written notice to the Consultant the Department may terminate all or any part of this Contract, at any time, without fault on the part of the Consultant. At the discretion of the Department, all or any of the work of the Consultant may be abandoned or indefinitely postponed. Under any of these conditions, the Consultant will be paid for work completed and should this Contract be terminated in whole or in part; the Consultant's compensation will be adjusted to reflect such termination. When appropriate, the engineering fee shall be re-computed for the reduced scope of work in the same manner used for determining the original Contract fee.
- 12.2. This Contract may be terminated by any of the following conditions:
  - 12.2.1. By mutual agreement and consent, in writing of both parties.
  - 12.2.2. By the Department by written notice to the Consultant as a consequence of failure by the Consultant to perform the services set forth herein in a satisfactory manner.
  - 12.2.3. By either party, upon the failure of the other party to fulfill its obligations as set forth herein.
  - 12.2.4. By the Department for reasons of its own and not subject to the mutual consent of the Consultant upon five (5) days written notice to the Consultant.

- 12.2.5. By satisfactory completion of all services and obligations described herein.
- 12.3. Should the Department terminate this Contract as herein provided, no compensation other than compensation earned at the time of termination plus reasonable costs to bring work to a logical conclusion shall thereafter be paid to the Consultant. The Consultant will not initiate new work after receipt of notice of termination. In determining the value of work performed by the Consultant prior to termination, the Department shall be the sole judge. Compensation for work at termination will be based on a percentage of the work completed at the time of termination. The Consultant shall be paid for actual hours worked and expenses incurred. Under no circumstances shall the Consultant be compensated an amount greater than the not to exceed amount.
- 12.4. Should the Department terminate this Contract under paragraph 12.2.4 above, the amount charged during the five (5) day notice period will not exceed one-sixth (1/6) of the amount charged during the preceding thirty (30) days.
- 12.5. If the Consultant defaults in the performance of the Contract or if the Department terminates this Contract for fault on the part of the Consultant, the Department at its sole discretion shall give consideration to the actual costs incurred by the Consultant in performing the work to date of default, the amount of work required which was satisfactorily completed to date of default, the value of the work which is usable to the Department, the cost to the Department of employing others to complete the work required and the time required to do so, and other factors which affect the value to the Department of work performed at the time of default.
- 12.6. The termination of the Contract and payment of an amount in settlement as prescribed above shall extinguish all rights, duties, and obligations of the Department and the Consultant under this Contract, except the obligations set forth in this Section 12: Termination and Default. If the termination of this Contract is due to the failure of the Consultant to fulfill its obligations under this Contract, the Department at its sole discretion may complete the work using its own forces or the services of others.
- 12.7. The Consultant will be responsible for the settlement of all contractual and administrative issues arising out of any procurement or sub-contract made by the Consultant under this Contract.

### **SECTION 13. SUB-CONTRACTS**

- 13.1. It is anticipated that the Consultant may need to sub-contract a portion of this work, however; unless otherwise authorized in writing by the Department, the Consultant shall not assign any portion of this Contract by executing any sub-contract, amendment, or change order thereto, or obligate itself in a manner with any third party with respect to its rights and responsibilities under this Contract.



The written approval of the Department for sub-contracting of work required by the Contract shall not be unreasonably withheld. Additionally:

- 13.1.1. The Consultant will complete a First Tier Sub-Consultant Participation form, as provided in Exhibit "A", Attachment B2. The Department reserves the right to reject any Sub-Consultant.
- 13.1.2. The Consultant will specifically itemize all Sub-Consultant payments and will include such with each invoice.
- 13.1.3. Certain provisions and restrictions of this Contract will also apply to all Sub-Consultants. The Consultant will include applicable terms and conditions in all sub-contracts.

## **SECTION 14. INDEMNIFICATION**

- 14.1. The intent of this Contract is for the Department to acquire the professional engineering services of Consultant to perform the services called for in this Contract for the project or projects described. The services are to be performed in accordance with tenable and established engineering practices and the Department's standard requirements. The standard of care for tenable and established engineering practices shall be the care and skill ordinarily used by members of the same profession currently practicing under similar circumstances. The Department reserves the right, but does not commit itself, to review the work of the Consultant for errors, omissions, and work which is contrary to standards or tenable engineering practice, and to provide the Consultant with its findings. It is specifically agreed that a review of the work by the Department, if any, does not relieve the Consultant of its responsibility as a professional engineering Consultant to prepare and provide the Department with services performed in accordance with accepted standards and tenable engineering principles. In no event shall Consultant assume the Department will review Consultant's work for errors or omissions, but rather Consultant shall assume that the work called for under this Contract will not be reviewed and will provide the Department with documents which are in all respects ready for use in the construction of the project or such other use as may be set forth in this Contract.
- 14.2. That the Consultant will be held responsible for the accuracy of engineering details and any unit, quantity or other computations related to the work to be performed and will hold and save the Department harmless from any and all claims for damage or causes of action resulting from plan errors or omissions which amount to professional negligence on the part of the Consultant or its Sub-Consultants. The Consultant will be held responsible for any mistakes or omissions in the work of the Consultant which appear during the final review, if any, by the Department prior to advertising the contract, during the letting process, or during the construction, and the Consultant will be required to do any

work on the plans necessary to correct the mistakes or omissions in the work, including submitting computations to support said corrections to plans without additional compensation. The Consultant shall be given timely written notice and the opportunity to correct any errors or omissions in plan documents. The Consultant may thereafter be held liable for any additional cost incurred by the Department for construction or construction delays, which resulted from plan errors or omissions which amount to professional negligence as defined below. Frequent occurrence of irregularities in engineering details or quantities will be a basis for withholding future construction contracts from the Consultant. Professional negligence shall be defined as failure to conform with accepted engineering standards to include the exercise of reasonable care and professional skill in the preparation of plans, the performance of related engineering services and the conduct of work.

## **SECTION 15. INSURANCE**

- 15.1. During the performance of the professional engineering services under this Contract, the Consultant shall maintain policies of insurance in the minimum amount as set forth herein or as required by the laws of the State of Oklahoma, whichever is greater:
  - 15.1.1. General Liability Insurance with bodily injury and property damage limits of not less than one million dollars (\$1,000,000.00) coverage for all damages arising out of bodily injury, death and property damages and with limits of not less than one hundred seventy-five thousand dollars (\$175,000.00) for each claimant and with an aggregate limit of not less than two million dollars (\$2,000,000.00). Said insurance policy to protect the Consultant against claims and suits in law or equity, alleging negligence on the part of said Consultant, his agents or employees and demands for compensation for damages to either persons or property.
  - 15.1.2. Automobile Liability Insurance with bodily injury limits of not less than one million dollars (\$1,000,000.00) for each person and not less than one million dollars (\$1,000,000.00) for each accident and with property damage limits of not less than one hundred seventy-five thousand dollars (\$175,000.00) for each accident.
  - 15.1.3. Worker's Compensation Insurance in accordance with the statutory requirements of the State of Oklahoma.
  - 15.1.4. Professional Liability Insurance with limits of not less than one million dollars (\$1,000,000.00) with prior act endorsement for the insurance to remain in effect for a minimum of two (2) years after acceptance of the project by the Department. Valuable papers insurance in the face amount of not less than fifty-thousand dollars (\$50,000.00) per project.

Said insurance is to assure the restoration in the event of loss or destruction of any notes, drafts, diaries, computer data or media as may be used or developed as a part of prosecution of this Contract.

- 15.1.5. The Consultant shall furnish to the Department certificates of insurance showing he or she is carrying insurance in at least the specified minimum amounts. Said certificates shall further provide that the insurer will not cancel said insurance without the insurer first giving the Department ten (10) days written notice of cancellation.
- 15.1.6. The Consultant shall not cause any insurance policy to be canceled or permit it to lapse and all insurance policies shall include an endorsement to the effect that the insurance policy or certificate shall not be subject to cancellation or to a reduction in the required limits of liability or amounts of insurance until notice has been mailed to the Department, stating the date when such cancellation or reduction shall be effective, which date shall not be less than ten (10) days after such notice.
- 15.1.7. The Consultant shall provide the Department for the inclusion in the Contract file copies of certificates of insurance evidencing coverage as to workers compensation, and liability, said copies to be furnished to the Department with the execution of this Contract.

## **SECTION 16. ACCESS TO RECORDS AND AUDIT REQUIREMENT**

- 16.1. The Consultant and its Sub-Consultants are to maintain all books, documents, papers, accounting records, and other evidence pertaining to costs incurred and to make such materials available at its respective offices at all reasonable times, during the Contract period and for three (3) years from the date of final payment under the Contract, for inspection by the Department, representatives of the Department, and if requested, to the State Auditor and Inspector, the Federal Highway Administration, the Comptroller General of the United States, or any other authorized representative of the Federal or state governments.
- 16.2. The Consultant shall provide an audit of its indirect cost rate (overhead rate plus benefits and taxes, also identified as the labor additive rate) established by a cognizant agency or a qualified independent CPA which has been performed in accordance with cost principles contained in 48 Code of Federal Regulations, Part 31 and the AASHTO Audit Guide. The Department retains the right to examine the CPA's work papers of Consultant's indirect cost rate audit.
- 16.3. An audited FAR indirect cost rate and related information must be submitted by the Consultant to the Department for review and acceptance no later than July 31<sup>st</sup> following the end of the previous calendar year. A provisional overhead rate may be used until such time that an annual overhead rate is audited and

established. In the event the Consultant is unable to provide the audit report within the time frame specified, the Consultant shall submit a written request for an extension citing the reason for the delay. Submittal of the Consultant's annual indirect cost rate audit will be documented in the Consultant's contract evaluation.

**SECTION 17. NOTICES**

17.1. All notices, demands, requests, or other communications which may be or are required to be given, served or sent by either party to the other pursuant to the Contract shall be in writing and shall be deemed to have been properly given or sent:

17.1.1. If intended for the Department, mailing first class mail or, if sender prefers, by registered or certified mail, return receipt requested, with postage prepaid addressed to State at:

Oklahoma Department of Transportation  
Project Management Division  
200 NE 21<sup>st</sup> Street Room 3-C9  
Oklahoma City, Oklahoma 73105-3204

17.1.2. If intended for Consultant, by mailing by first class mail or, if sender prefers, by registered or certified mail, return receipt requested, with postage prepaid, addressed to the Consultant at:

**SECTION 18. CIVIL RIGHTS ACT OF 1964**

18.1. The Consultant agrees to comply with Title VI of the Civil Rights Act of 1964, 78 Statute § 252, 42 U.S.C. § 2000d et seq., and all requirements imposed by or pursuant to Title 49, Code of Federal Regulations, Part 21 – “Nondiscrimination in federally assisted programs of the Department of Transportation – effectuation of Title VI of the Civil Rights Act of 1964” (See Attachment D3).

**SECTION 19. DESIGNATION OF PROJECT MANAGER AND KEY PERSONNEL**

19.1. For the purposes of this Contract, the Consultant has provided a list of individuals and Sub-Consultants and their qualifications and experiences, as further identified in Exhibit “A”, Attachment B1 – Key Personnel and Attachment B2 – Sub-Consultant Participation, who will serve as the primary workforce for the project. Any personnel substitutions for these individuals will be subject to approval of the Department.

19.2. The Department reserves the right to have any of the Consultant's employees removed from participation in the performance and execution of this Contract if it believes it is in the best interest of the Department. Any employee of the Consultant or Sub-Consultants who, in the opinion of the Chief Engineer, is judged to be incompetent of producing quality work or their conduct becomes detrimental to the project shall, upon written request of the Chief Engineer be immediately removed from association with the project.

#### **SECTION 20. ENGINEER'S / SURVEYOR'S SEAL**

20.1. The Consultant's engineer and/or surveyor shall place his/her professional seal of endorsement and signature on all the documents, survey information and engineering data furnished to the Department when such is required by the Level or Type of Service defined by this Contract and additionally, as may be required by State Law.

#### **SECTION 21. HEADINGS**

21.1. Article headings used in this Contract are inserted for convenience of reference only and shall not be deemed a part of this Contract for any purpose.

#### **SECTION 22. BINDING EFFECT**

22.1. This Contract shall be binding upon and inure to the benefit of the Department and the Consultant and shall be binding upon their successors and assigns subject to the limitations of Oklahoma Law.

#### **SECTION 23. SEVERABILITY**

23.1. This Contract shall be construed in conformance with the Constitution and Laws of the State of Oklahoma. The provisions of this agreement shall be considered as several. In the event that any provision of the agreement is determined, by a court of competent jurisdiction, to be contrary to the Constitution or Laws of the State of Oklahoma, such finding shall not invalidate the remaining provisions of this agreement if the same shall permit completion of the work set forth in this Contract. Venue for any action to construe or have enforced any provision of this agreement shall be in the District Court of Oklahoma County, State of Oklahoma.

#### **SECTION 24. FRAUD AND FALSE STATEMENTS**

24.1. That Consultant understands that, if the project which is subject of this Contract is financed in whole or in part by federally furnished funds, that if the undersigned, the company that Consultant represents, or any employee or agent thereof, knowingly makes any false statement, representation, report, or claim as to the character, quality, quantity, or cost of material used or to be used, or

quantity or quality work performed or to be performed, or makes any false statement or representation as a material fact in any statement, certificate, or report, Consultant and the company that Consultant represents may be subject to prosecution under the provisions of 18 U.S.C.S. § 1001, §1020.

**SECTION 25. CONFLICT OF INTEREST**

25.1. That the Consultant understands that neither the Consultant nor any Sub-Consultant or any professionally certified member of the Consultant's or Sub-Consultant's staff may represent or act as a consultant for any person, company or association in any action, cause or forum where the claim of that person, company or association is contrary to the interest of the Department. All such actions shall be considered conflicts of interest and shall be deemed as a default under the terms of this Contract. For any violation of this section, the Department, at its sole discretion, shall have the right to terminate this Contract without liability as provided in Section 12 and may withhold future engineering contracts from the Consultant and/or Sub-Consultant.

**SECTION 26. EFFECTIVE DATE /CONTRACT PERIOD**

26.1. This Contract becomes effective when fully executed by all parties and will remain in effect as defined by the requirements of the work. This Contract may also be extended beyond the requirements of the work by means of a Supplemental Contract mutually agreeable to by all parties.

**IN WITNESS WHEREOF:** The Consultant executes this Contract on the \_\_\_\_ day of \_\_\_\_\_, 20\_\_\_\_; and the Department on the \_\_\_\_ day of \_\_\_\_\_, 20\_\_\_\_.

(Corporate Seal)

Consultant

Federal Tax Number

\_\_\_\_\_  
(If individual/ Partnership/ Sole Proprietorship "D/B/A")

STATE OF \_\_\_\_\_ )  
 ) §:  
COUNTY OF \_\_\_\_\_ )

Subscribed and sworn before the undersigned on the \_\_\_\_ day of \_\_\_\_\_, 20\_\_\_\_.

\_\_\_\_\_  
Notary Public

My Commission Expires: \_\_\_\_\_

My Commission Number: \_\_\_\_\_

Approved:

\_\_\_\_\_  
Federal Highway Administration      Date

Transportation Commission Item No. \_\_\_\_\_

Dated: \_\_\_\_\_

\_\_\_\_\_  
President      Date

Attest:

\_\_\_\_\_  
Secretary (If CORP)      Date

RECOMMENDED FOR APPROVAL:

\_\_\_\_\_  
Director of Engineering      Date

Approved as to Form and Legality:

\_\_\_\_\_  
General Counsel      Date

FOR THE DEPARTMENT

\_\_\_\_\_  
Chief Engineer      Date

**OKLAHOMA DEPARTMENT OF TRANSPORTATION  
ENGINEERING CONTRACT NO. EC-  
EXHIBIT "A" – INDEX OF SPECIFICATIONS AND SPECIAL PROVISIONS**

**ATTACHMENT A – SPECIAL CONTRACT PROVISIONS AND REQUIREMENT**

- A1. Scope of Services
- A2. Baseline Schedule/Cost Estimates
- A3. Schedule of Progressive Payments
- A4. Plan Preparation
- A5. Location and Hydraulic Design of Encroachments on Flood Plains
- A6. Specifications for Detailed Construction Plans for Grading, Drainage, Surfacing, Structures and Incidentals
- A7. LRFD Bridge Design Specifications for Highway Bridges
- A8. Geotechnical Fee Schedule
- A9. Survey Special Provisions

**ATTACHMENT B – CONSULTANT STAFFING**

- B1. Key Personnel
- B2. Sub-Consultant Participation
- B3. Approved Hourly and Overhead Rates

**ATTACHMENT C – TASK ORDER REQUIREMENTS AND PROCEDURES**

**ATTACHMENTS D – FEDERAL HIGHWAY ADMINISTRATION CONTRACT  
REQUIREMENTS**

- D1. US DOT Certification for Federal-Aid Contracts
- D2. US DOT Certification of Eligibility
- D3. Title VI of the Civil Rights Act of 1964
- D4. Drug Free Workplace
- D5. Disadvantaged Business Enterprises Policy Statement
- D6. Federal Highway Administration Contract Requirements

**ATTACHMENT E – STATUTORY AFFIDAVIT**

**ATTACHMENT F – STATUS VERIFICATION SYSTEM AFFIDAVIT**

**ATTACHMENT G – CERTIFICATE OF FINAL INDIRECT COSTS**

**ATTACHMENT H – FINAL INVOICE CERTIFICATION**



**OKLAHOMA DEPARTMENT OF TRANSPORTATION  
ENGINEERING CONTRACT NO. EC-  
ATTACHMENT A1  
SCOPE OF SERVICES**

**SECTION 1: GENERAL SCOPE**

**OKLAHOMA DEPARTMENT OF TRANSPORTATION  
ENGINEERING CONTRACT NO. EC-  
ATTACHMENT A2  
BASELINE SCHEDULE / COST ESTIMATES**

**SECTION 1: SCHEDULING REQUIREMENTS**

1.1 Baseline Schedule

- 1.1.1 A baseline project schedule indicating the preconstruction activities to be monitored and the anticipated completion dates for milestones are included in Section 1.3.1.

1.2 Monthly Schedule Update

- 1.2.1 The Consultant will report detailed input and schedule updates on all preconstruction activities in accordance with the Baseline Schedule on a monthly basis. All preconstruction activities must be addressed each month even if there is no change in status. Following the Notice to Proceed, this report will be considered due to the Department on or before the fifth (5<sup>th</sup>) day of each month.
- 1.2.2 A brief narrative describing scheduled milestones with the status for each and a projection of milestone activities anticipated for the next sixty (60) days will be included in the report.
- 1.2.3 In the event that milestone dates are compromised for any reason, the Consultant will participate in a schedule review and assessment with the Department and the results will be incorporated into the report. The schedule review and assessment may include but is not limited to a detailed critical path analysis, consideration of potential delays, development of recovery plans, reporting recovery activities which are underway, assessing the impact of delays and developing plans for schedule recovery.
- 1.2.4 The Department will evaluate the schedule review and assessment results as reported by the Consultant to determine if adequate provisions are proposed to enable the project to progress in accordance with the Baseline Schedule. If it is determined that an adjustment to the Baseline Schedule is warranted and if the delays are not directly attributed to the operations and/or project management practices of the Consultant as required by this Contract, the Department may grant an appropriate extension of time to complete all or any phase of the work. The Consultant will incorporate recommendations for such time extensions into the monthly schedule update report as described above in Paragraph 3.

1.2.5 The Department reserves the right, but does not assume the obligation, to intercede at any time should the Consultant fail to demonstrate the ability to progress the project in accordance with the milestone dates established in the Baseline Schedule. Such action on the part of the Consultant shall be considered non-performance and the Department shall have all rights to seek remuneration and other damages as provided for in this Agreement and the laws of the State of Oklahoma.

1.3 Project Development Process

1.3.1 Preconstruction activities should at a minimum include the following elements as applicable.

PROJECT DEVELOPMENT PROCESS			
WBS	Task Name	Milestone Date	Comments
1	<b>Initiation</b>		
1.1	Prepare Recon Report		
1.2	Prepare Final Initiation Report		
2	<b>NEPA</b>		
2.1	Conduct Environmental Studies		
2.2	FHWA Final Document Approval		
3	<b>Plan Development</b>		
3.1	Conduct Survey		
3.2	Perform Bridge Hydraulic Conference		
3.3	Preliminary Plan Field Review Meeting		
3.4	Right-Of-Way & Utility Meeting		
3.5	Submit Construction Plans for Right-Of-Way		
3.6	Final Plan Field Review Meeting		
3.7	Final Submission Package		
4	<b>Land Acquisition</b>		
4.1	Obtain Legal Entry		
4.2	Conduct Utility Relocation		
5	<b>Letting</b>		
5.3	Award		

1.3.2 The duration of the Contract should extend through the construction project lettings as part of the normal project development process.

## **SECTION 2: COST ESTIMATING REQUIREMENTS**

### **2.1 Baseline Cost Estimates**

2.1.1 Following the Notice to Proceed for this Contract, the Consultant will review the existing project cost estimate for the project(s) and submit a written confirmation and/or recommendations for any refinements, changes, and revisions to the Department. The Department will consider any project cost estimate recommendations and issue a final Baseline Cost Estimate.

### **2.2 Cost Estimate Updates.**

2.2.1 The Consultant will update the Baseline Cost Estimate at the preliminary plan field review, the Right-of-Way plan submittal, final plan field review, the Constructability review, the completion of the final design effort and after any significant changes in the scope of the project as defined in this Contract.

2.2.2 In the event that the Baseline Schedule is suspended or delayed in any manner, additional updates of the Baseline Cost Estimate will be required at six (6) month intervals as long as this Contract remains in effect. The Department may suspend this requirement by issuing a written notice to the Consultant.

**OKLAHOMA DEPARTMENT OF TRANSPORTATION  
ENGINEERING CONTRACT NO. EC-  
ATTACHMENT A3  
SCHEDULE OF PROGRESSIVE PAYMENTS**

1. For the purpose of partial payments as provided in this schedule, these amounts will be used:

1.1.	Roadway	\$
1.2.	Bridge	\$
1.3.	Roadway Geotechnical	\$
1.4.	Bridge Geotechnical	\$
1.5.	Survey	\$
1.6.	Task Orders for Services Already in Contract.	\$
TOTAL		\$

2. PROGRESSIVE PAYMENTS:

2.1. Progressive payments, subject to the faithful performance of all the terms and provisions of this Engineering Contract and to the limitations hereinafter set out, will be as follows:

2.1.1. Invoices, accompanied by detailed descriptions of the total work accomplished, will be submitted to the Department by the Consultant for payment on work completed to date. The invoices will not be submitted more than once per month during the progress of the work.

2.2. The Department, for and in consideration of the rendering of the engineering services heretofore or hereinafter enumerated, agrees to pay to the Consultant for rendering such services, the total of lump sum for each phase of the work established above in the following manner:

2.2.1. ROADWAY PLANS:

2.2.1.1. Title and P&P sheets prepared and submitted with preliminary grade for soils survey.  
15%

- 2.2.1.2. Typical section submitted and approved.  
25%
- 2.2.1.3. Construction plans submitted and accepted by the Department for preliminary plan field review. Revised cost estimate.  
30%
- 2.2.1.4. Revisions from preliminary plan field review incorporated.  
50%
- 2.2.1.5. Construction Right-of-Way plans and revised cost estimate submitted.  
60%
- 2.2.1.6. Right-of-Way plans completed, ready to acquire Right-of-Way.  
65%
- 2.2.1.7. Final construction plans submitted for final field review meeting. Revised cost est., all calculations submitted.  
90%
- 2.2.1.8. Final field review meeting comments incorporated in plans.  
95%
- 2.2.1.9. Final corrected Construction plans, specifications and estimates (PS&E) submitted and accepted by the Department.  
100%

2.2.2 BRIDGE PLANS:

- 2.2.2.1 Concepts and Architectural Renderings including site and detailing sketches if applicable.  
10%
- 2.2.2.2 Ready for preliminary plan field review. Revised cost estimate.  
20%
- 2.2.2.3 Preliminary plan field review report written.  
25%

- 2.2.2.4 Final geometric and preliminary field review revisions complete.  
30%
- 2.2.2.5 Structural design completed.  
60%
- 2.2.2.6 Final Construction plans submitted for final field review. Revised cost est., all calculations submitted.  
90%
- 2.2.2.7 Final field review meeting comments incorporated  
95%
- 2.2.2.8 Final corrected Construction plans, specifications and estimates (PS&E) submitted and accepted by the Department.  
100%

2.2.3 GEOTECHNICAL INVESTIGATIONS:

- 2.2.3.1 Field sampling and testing complete.  
30%
- 2.2.3.2 Laboratory tests and analysis.  
60%
- 2.2.3.3 Field geotechnical report delivered to the Department.  
80%
- 2.2.3.4 Final report reviewed and accepted by the Department.  
100%

2.2.4 SURVEY:

- 2.2.4.1 Reconnaissance for aerial photography complete.  
5%
- 2.2.4.2 Preliminary research and alignment studies complete.  
10%
- 2.2.4.3 Horizontal and vertical control surveys complete.  
15%

APPENDIX 5

- 2.2.4.4 Design photography and photo control complete.  
25%
- 2.2.4.5 Aerotriangulation complete.  
30%
- 2.2.4.6 Final alignment determined.  
35%
- 2.2.4.7 Centerline of Survey staked and field profile obtained.  
40%
- 2.2.4.8 Land and property surveys complete.  
55%
- 2.2.4.9 Compilation and drafting of topographic maps complete.  
60%
- 2.2.4.10 Identification of topographic/planimetric data complete and entered.  
70%
- 2.2.4.11 Drainage/Hydraulics/Hydrology surveys complete.  
80%
- 2.2.4.12 Additional surveys (railroads, section line roads, connecting roads, etc.) complete.  
90%
- 2.2.4.13 Completion of office work and final submittal made.  
100%



**OKLAHOMA DEPARTMENT OF TRANSPORTATION  
ENGINEERING CONTRACT NO. EC-  
ATTACHMENT A4  
PLAN PREPARATION**

**SECTION 1: PLAN PREPARATION**

- 1.1 This section is to be used when applicable as a general guide for construction plan preparation. Any information not contained in this provision is available from the Department's authorized personnel. For right-of-way plan preparation, refer to "ODOT Right-of-Way Specification Manual for Preparation of Plans and Documents".
- 1.2 The Department's policy of reducing the plans fifty percent (50%) has necessitated that a compatible drafting technique be utilized. The Department maintains the right to reject any plans, which are not of reducible quality.
- 1.3 The Consultant should acquire from the Department a sample set of plans to use as guides, and should be acquainted with Department drafting practices. These plans are not to be considered policy or standards, but merely to serve as an aid in plan preparations.

**SECTION 2: DRAFTING MEDIA**

- 2.1 The Consultant shall submit the final plans in all the following formats:
  - 2.1.1 One (1) complete set of full-size (23" X 36") plan sheets on white bond (20lb. min.) with original signatures and professional seals. Sheets must be high quality and free from "stick-on" or other surface adhesives.
  - 2.1.2 One (1) complete set of half-size (11" X 17") plan sheets on white bond (20lb. min.) with original signatures and professional seals.
  - 2.1.3 One (1) complete set of plans electronically archived on Windows Compatible CD(s) with complete CADD design files in Microstation format with accompanying Geometric Alignments, COGO and Surface data files in ASCII text format, InRoads Alignment(.alg), Surface (.dtm), and Land XML Standard file formats (see Digital File Formats for examples).
  - 2.1.4 One (1) complete set of final plans exported to .pdf format on Windows Compatible CD(s).

- 2.2 The Consultant is responsible for any translation required to convert Non-Microstation design files to Microstation format and submitting all translation files used during the conversion. All translated design files shall conform to the applicable standards adopted by the Department.
- 2.3 The computer files name proceeding the .dgn extension shall have a maximum of eight (8) characters and named similar to the following:
- 2.3.1 Title Sheet - tit\_\_\_\_.dgn (fill in blanks with first 5 digits of job/piece number)
  - 2.3.2 Typical Section – typ\_\_\_\_.dgn (fill in blanks with first 5 digits of job/piece number)
  - 2.3.3 Summary Sheet – sum\_\_\_\_.dgn (fill in blanks with description: pay, drain, misc.)
  - 2.3.4 P&P Sheet – pp\_\_\_\_.dgn (fill in numerical order 01, 02, 03, etc.)
  - 2.3.5 Cross Sections – xsec\_\_\_\_.dgn (fill in descriptor if needed)
- 2.4 If the Consultant submits plan sheets on paper that does not meet specifications, or if the Department has to reduce the full-size plans to half-size paper, the Department will charge the Consultant at the current rate established by Department's Reproduction Branch to reproduce the sheets in the standard format.

### **SECTION 3: DRAFTING CONVENTIONS**

#### **3.1 Scales:**

- 3.1.1 The plan sheets shall be drawn to a scale, which will allow for neat drafting and note placement. Preliminary designs for the Ultimate Facility (functionals) are to be drawn to a scale no smaller than 1'=200' horizontal and 1'=20' vertical. Plan and profile sheets should be drawn to a scale no smaller than 1'=100' horizontal and 1'=10' vertical and may need to be of larger scale depending on the amount of construction details and topography required to produce an acceptable set of plans. All sheets, including detail sheets, shall be of sufficient scale to show all details and lettering clearly when reduced to fifty (50%) percent of original size. The Consultant at no additional expense to the Department shall redraw congested sheets rejected by the Department.

#### **3.2 Lettering Size:**

- 3.2.1 Freehand lettering shall be no smaller than the No. 4 setting on the Ames lettering guide (3mm minimum height).
- 3.2.2 Mechanical lettering shall be at least comparable to the 120 guide (Leroy) or 3mm minimum height.
- 3.2.3 These lettering sizes are minimums; sizes greater than these are desirable and suggested.
- 3.3 Linework:
  - 3.3.1 All Linework shall be of sufficient density to be reproducible by current Department reproductive processes. Any linework that does not reproduce may be cause for rejection of the plans by the Department.
- 3.4 Halftones, Screened Photographs, Shadings:
  - 3.4.1 The multitude of methods available requires that the finished product, rather than the method, be acceptable to the Department. A final project from any method, which is not reducible fifty percent (50%), and reproducible on the existing Department equipment may be rejected in its entirety. It is deemed advisable to contact the Department's authorized representative (the project engineer, or the reproduction branch manager) and obtain approval on any questionable method or material prior to its use on the plans.

#### **SECTION 4: SUBMISSION OF PAY ITEMS/QUANTITIES**

- 4.1 The Consultant shall submit final Pay Items/Quantities in following formats:
  - 4.1.1 Trans-Port Software "Estimator" will be used to generate a (.est) file. This file will contain the Categories (Roadway, Bridge, Traffic, Staking, etc.) and the pay items/quantities for each appropriate category that will be required to complete the Construction Project. The purchase of this software will be the responsibility of the Consultant. The Estimator file will be named using the seven (7) digit job/piece number for the project and start with 'j' as in, for JP No. 12345(07) the file will be named jp 1234507.he and will be submitted with other electronic and hard copy files as part of the final submission. The import of the Estimator file will be the responsibility of the ODOT Engineering Manager in charge of the project.

#### **SECTION 5: DIGITAL FILE FORMATS**

Digital Surface information shall be provided in either InRoads (.dtm) file, Graphic (3D .dgn), or ASCII (.txt or .dat) format.

Surface and Alignment data shall also be provided in Land XML standard format.

**InRoads .dtm** (Digital Terrain Model) file is the most preferred.

**Graphic:** Elements must be a 3D MicroStation .dgn file. The Random Points, Exterior, and Breakline graphics must be displayed on different levels.

Random Points Displayed on DTM\_Misc level

Exterior Boundary: Displayed on DTM\_Exterior level

Breaklines: Displayed on DTM\_Breakline level

Color, linestyle, symbology does not matter

**ASCII:** May use either a .txt or .dat file extension.  
Random points, Breaklines, etc. must be in separate files.

Coordinates should be input as decimal numbers and have the same units of measure as the master units of the currently active design file. If the data file contains point IDs, they should be input as integer numbers. All columns may be separated by blanks, tabs or commas. Records contained in the file having no data or beginning with the character ;, !, or \* are ignored.

Example Random Point file formats:

Column1	Column2	Column3	Column4
station	offset	elevation	based on Cross-sections
northing	easting	elevation	
easting	northing	elevation	
Point ID	station	offset	elevation
Point ID	northing	easting	elevation
Point ID	easting	northing	elevation

When loading points defining breakline, or interior or exterior boundary features, an additional field is required at the end of each record. Because multiple linear features may be stored in a single file, the additional field is used to distinguish one linear feature from the next. The additional field consists of numbers one or zero in the last column. The very first point record for each linear feature should contain 1 in the last column with all subsequent point records defining the same linear feature containing a 0 in the final column. The first point in the next linear feature would then contain 1 in the last column, and so on. You may interchange the order of the ones and zeros if you choose.

Alignment data shall be provided in InRoads (.alg) alignment file and Land XML standard format.

All alignments used to generate a surface ASCII file using Station, Offset and Elevation, must be provided. All alignments used to generate Cross-sections must be provided and labeled clearly.

ASCII format: may be in the .ics file format shown below or a simple alignment report stating the coordinate values for all event, PI, PC, CC and PT points used to define the alignment. The curve data shall include deflection, degree, radius, tangent and curve length information. Distance and Bearing between all points must be included.

ICS file format:

```
SET PARAMETER 1 0 0
DEL COOR (1-20000)
DEL FIG [100]
STORE
1 854123.52872512 136132.10295618
2 854275.16372509 136252.36295615
3 853974.66030537 135992.55220579
4 854279.90384810 136246.48317426
5 854022.15203005 135032.06037950
100 854272.93263615 136647.93454219 202.73555
101 854263.47721567 137176.42710815 201.73397
102 854262.87575997 136854.18667391
STORE FIGURE
1 ( 1 2 C3L 4 5 100 C102R 101)
```

Note: point numbers must start with a space Figure or alignment definition to pc, cc and pt points in that order. Center begin with a space, then the alignment number, points to be enclosed in Parenthesis. Curves defined using the pc, cc and pt points in that order. Center of curve defined starting with a C followed by the point number, followed by the direction of arc, to the right or the left.

## SECTION 6: SUBMISSION OF REPORTS

6.1 The Consultant shall submit all final reports in the following formats:

6.1.1 Ten (10) copies of a bound report.

6.1.2 One (1) completed report archived in either Microsoft Word (.DOC), or PDF format, or CD.

**OKLAHOMA DEPARTMENT OF TRANSPORTATION  
ENGINEERING CONTRACT NO. EC-  
ATTACHMENT A5  
LOCATION AND HYDRAULIC DESIGN OF ENCROACHMENTS ON FLOOD  
PLAINS**

**SECTION 1: LOCATION AND HYDRAULIC DESIGN OF ENCROACHMENTS ON  
FLOOD PLAINS**

- 1.1 Consultant shall refer to Federal Highway Administration Federal-Aid Policy Guide, 23 CFR 650A OPI: HNG-31 Subpart A, concerning Evaluation of Flood Hazards Federally Financed Highways.
- 1.2 All Federal and Federal-aid highway plans submitted for approval shall show, for bridge size drainage structures, the magnitude, approximate probability of exceedence, and the water surface elevation of the roadway overtopping flood; where overtopping is not practicable, the magnitude and water surface elevation of the 500-year flood shall be shown. For bridge size drainage structures, the magnitude and the water surface elevation of the 100-year flood shall be shown.
- 1.3 Roadway structures (less than 20 ft. in width of opening, including but not limited to: side/cross drains, inlets, storm sewer systems, etc.) shall have hydrologic/hydraulic studies performed.
- 1.4 The Consultant shall use the newest version of Oklahoma Department of Transportation Roadway Design Manual for design criteria. If the Consultant wants to use different design criteria, he or she must consult and get the approval in writing from the Roadway Drainage Engineer or the Engineer Manager in charge of the project.
- 1.5 The Consultant shall include the drainage map(s) and the hydraulic data sheet(s) in the plans submitted for approval, using the forms that have been accepted by Roadway Design Division. The Plan and Profile (P&P) sheets should show the size, length, material, flow in elevation, flow out elevation and slope of the proposed structures.
- 1.6 If the structures are located in a flood plain, the Consultant shall also file an application permit with the Oklahoma Water Resources Board, with a copy to the Department.
- 1.7 Checked Hydraulic Design Calculations shall be bound and submitted to the Department for review prior to plan-in-hand field inspection.

**OKLAHOMA DEPARTMENT OF TRANSPORTATION  
ENGINEERING CONTRACT NO. EC-  
ATTACHMENT A6  
SPECIFICATIONS FOR DETAILED CONSTRUCTION PLANS FOR GRADING,  
DRAINAGE, SURFACING, STRUCTURES AND INCIDENTALS**

**SECTION 1: SPECIFICATIONS FOR CONSTRUCTION PLANS**

- 1.1 Detailed construction plans shall be prepared to a horizontal scale no smaller than 1" = 100' and vertical scale no smaller than 1" = 10' for rural highways, and horizontal scale no smaller than 1" = 50' and vertical scale no smaller than 1" = 5' in built-up urban areas. The cross sections shall be on standard tracing paper sheets to a scale, both horizontal and vertical, of 1" = 5' for small sections and 1" = 10' for large sections. The construction plans shall include information and topography for drainage, drainage areas, drainage structures, utility lines, curve data, north arrows, bearings, fences, buildings, paving, roads, streets, property and right-of-way lines, driveways, intersections and interchanges, ramps, bridges, grade lines, profiles, earth work quantities, mass lines, limits of cut and fill slopes, detailed and summarized quantities of all materials, traffic control data and other necessary pertinent information. The functional plans, corrected to the final construction plans, shall be incorporated in the construction plans.
- 1.2 All final bridge plans will become the property of the Department. Complete bar lists for all reinforcing steel will be on the plans and the final plans will be comparable in details to the plans prepared for similar structures by the Department.
- 1.3 All sheet sizes shall meet the following requirements:
  - 1.3.1 Plan and Profile sheets shall be 23" X 36" with a border. See Detail "A" next page.
  - 1.3.2 Detail and cross section sheets shall be 23" X 36" with a border. See Detail "B" next page.
  - 1.3.3 Any printing or titles shall be placed inside the main border.

APPENDIX 5

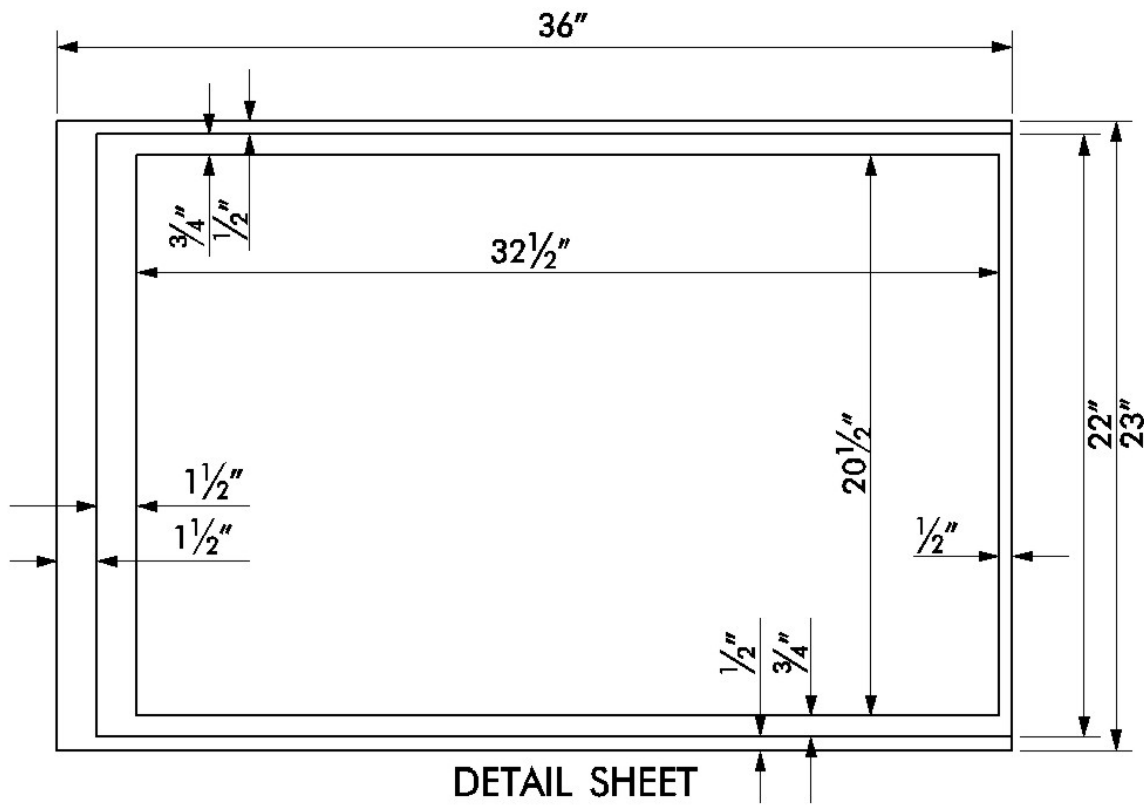
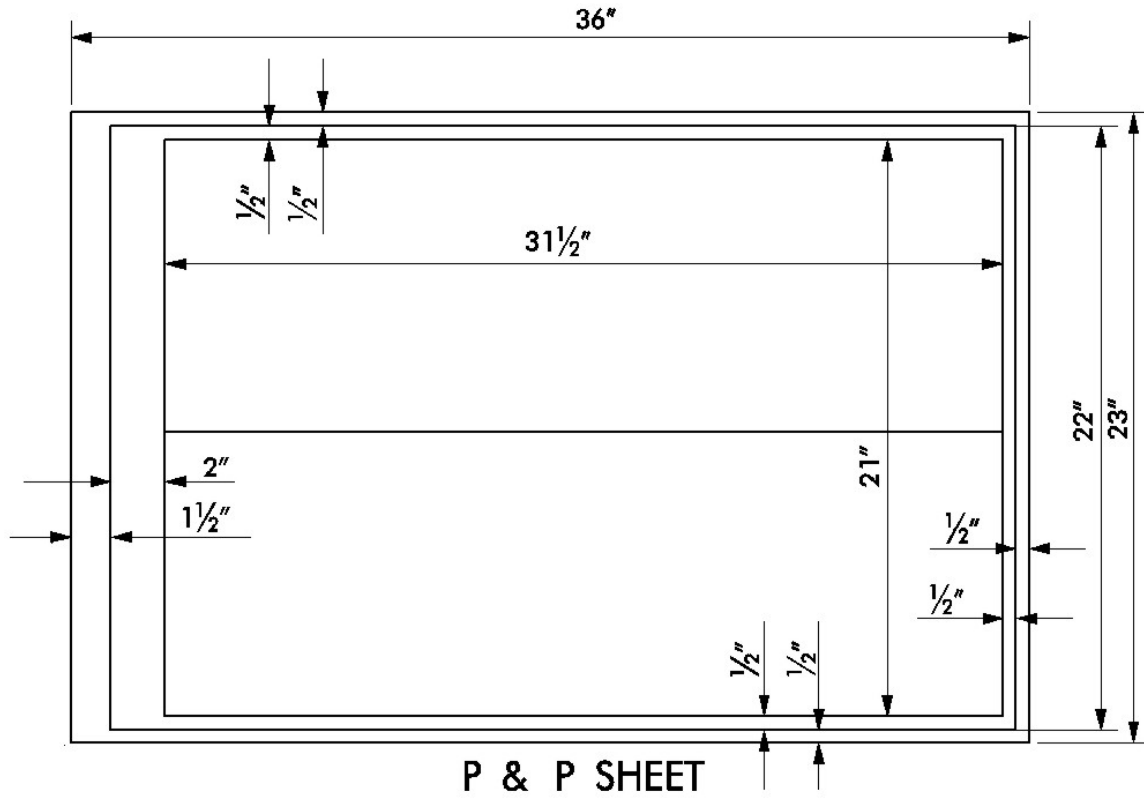



**OKLAHOMA DEPARTMENT OF TRANSPORTATION  
ENGINEERING CONTRACT NO. EC-  
ATTACHMENT A7  
LRFD BRIDGE DESIGN SPECIFICATIONS FOR HIGHWAY BRIDGES**

**SECTION 1: DESIGN SPECIFICATION**

- 1.1 The design and details for all bridges shall comply with the current LRFD bridge Design Specifications of the American Association of State Highway and Transportation Officials, (current American Railway Engineering A.R.E.A.) and AASHTO Guide Specifications for SEISMIC Design of Highway Bridges, except as modified herein.
- 1.2 The design and details for all bridges shall comply with the Concrete structures and shall be designed on the basis of concrete having an ultimate compressive strength at 28 days of 3,000 PSI for Class A and 4,000 PSI for Class AA Concrete. Precast prestressed concrete members shall be designed on the basis of  $f'c = 8,000$  PSI ordinarily and up to 10,000 PSI as approved by the Department. Post tensioned concrete members shall be designed for  $f'c = 4,000$  PSI ordinarily and up to 6,000 PSI if approved by the Department.
- 1.3 Bridges designed on the State Highway System for HL-93 loading shall provide sufficient capacity to support the Standard Overload Truck in accordance with Loading Combination Strength II in Article 3.4 of the AASHTO LRFD Bridge Design Specifications. A copy of the overload truck combination can be obtained from the Bridge Division.
- 1.4 Loads, roadway widths and clearances for all bridges shall comply with "A Policy on Geometric Design of Highways and Streets" by AASHTO, latest date.
- 1.5 The Consultant shall secure from the Department the latest design policies and procedures not covered under these specifications prior to starting the final design and preparation of the plans.
- 1.6 Light structures such as utility bridges, pedestrian over crossing, shall have vertical clearance increased 12" more than standard clearances.

**OKLAHOMA DEPARTMENT OF TRANSPORTATION  
ENGINEERING CONTRACT NO. EC-  
ATTACHMENT A8  
GEOTECHNICAL FEE SCHEDULE**

<b>Geotechnical Fee Schedule</b>						
Charge Item					UNIT	UNIT PRICES
1	Soil Classification (Gradation and P.I.)				each test	
2	Moisture Content				each test	
3	Specific Gravity	A.	Bridge (ASTM D-854)		each test	
		B.	Roadway (AASHTO T-100)		each test	
4	Chunk Density				each test	
5	ph Test	A.	Bridge (ASTM D-4972)		each test	
		B.	Roadway (AASHTO T-289)		each test	
6	Hydrometer, Double Hydrometer, or Pinhole Test	A.	Hydrometer		each test	
		B.	Double Hydrometer		each test	
		C.	Pinhole Test		each test	
7	Electrical Resistivity Per Test	A.	Bridge (AASHTO T-289 / ASTM G-57)		each test	
		B.	Roadway (AASHTO T-288)		each test	
8	Soluble Sulfate Test				each test	
9	Slake Durability				each test	
10	Unconfined Compression Test	A.	Soil and Rock		each test	

APPENDIX 5

		B.	Rock with Axial Strain Measurement		each test	
11	Point Load Test				each specimen	
12	Moisture-Density Test	A.	AASHTO T-99	Method A	each test	
				Method B	each test	
				Method C	each test	
				Method D	each test	
		B.	AASHTO T-180	Method A	each test	
				Method B	each test	
				Method C	each test	
				Method D	each test	
		C.	ASTM D-698	Method A	each test	
				Method B	each test	
				Method C	each test	
		D.	ASTM D-1557	Method A	each test	
				Method B	each test	
				Method C	each test	
13	One Dimensional Consolidation Test				each test	
14	Drained Direct Shear Test	A.	Cohesionless Soil		each test	
		B.	Cohesive Soil		each test	
15	Triaxial Shear Test	A.	Unconsolidated Undrained		each test	

APPENDIX 5

		B.	Consolidated Undrained-Pore Pressure Measurement		each test	
16	Resilient Modulus				each test	
17	Percent Swell and Swell Pressure Test				each test	
18	Geotechnical Drilling (Soil & Rock)	A.	Soil		feet	
		B.	Soft Shale & Rock (Permian & Pennsylvanian Formation)		feet	
		C.	Hard Rock (Hard Sandstone of the Jack Fork Formation, Limestone, and Chert)		feet	
		D.	In-place and Shoulder Survey		feet	
		E.	Pedological Sampling		feet	
19	Standard Penetration Test				each test	
20	Dynamic Cone Penetration Test (Texas Cone Penetrometer)				each test	
21	Dynamic Cone Penetrometer (DCP)				feet	
22	Thin-Walled Tube Sampling				each sample	
23	Mechanical and Electrical Friction Cone and Piezocone, Penetration Testing of Soils				feet	
24	Pressuremeter Test	A.	Soil		each test	
		B.	Rock		each test	
25	Dilatometer Test				each test	
26	Seismic Test	A.	Engineering Surveys	12 Channel Spread	each shot point	
		B.	Engineering Surveys	24 Channel Spread	each shot point	
		C.	Rippability Surveys	12 Channel Spread	each shot point	

APPENDIX 5

		D.	Rippability Surveys	24 Channel Spread	each shot point	
27	Monitoring Well				feet	
28	Field Permeability Test				each test	
29	Water Sampling and Testing				each test	
30	Hole Abandonment				feet	
31	Dozer Working Time				hours	
32	Traffic Control				Negotiated per task order	
33	Towboat/Barge Mobilization of Equipment	A.	Mobilization of Equipment		Negotiated per task order	
		B.	Daily Rate		Negotiated per task order	
34	Mobilization of Equipment				miles	
35	Engineering	A.	Slope Stability Analysis		hours	
		B.	Settlement Analysis		hours	
		C.	Retaining Wall Analysis		hours	
		D.	Bearing Capacity Analysis		hours	
		E.	End Bearing and Friction Pile Analysis		hours	
		F.	End Bearing and Friction Drilled Shaft Analysis		hours	
		G.	Seismic Analysis		hours	
		H.	Report Preparation		hours	
		I.	Miscellaneous Analysis		hours	

APPENDIX 5

36	Miscellaneous Labor, Materials, and Equipment as required to meet Section 404 Requirements				Negotiated per task order	
37	Deflection Testing, Pavement Evaluation & Reporting	A.	Pavement Coring	Mobilization	per mile	
				Concrete Coring	each core	
				Asphalt Coring	each core	
		B.	Distress Identification	Mobilization	per mile	
				Identification	lane-mile tested	
		C.	FWD	Mobilization	lump sum	
				Deflection Testing	lane-mile tested	
		D.	Ground-Penetration Radar	Mobilization	miles	
				GPR Test	lane-mile tested	
38	Site Access	A.	Mileage		miles	
		B.	On-Site		hours	
39	Pedological Research/Assessment				hours	
40	Survey				Negotiated per task order	
41	Rock Dilatometer Test				each test	

**Staff.** The Geotechnical Engineering Consultant will provide an Oklahoma Registered Professional Engineer (PE) who has at least four (4) years of experience in geotechnical engineering to perform the supervision of field logging & sampling, in situ testing, and laboratory testing. Resumes of the Geotechnical Engineering Consultant's Geotechnical Engineer and field engineers are to be submitted to the Roadway Design Division for approval. Interviews will be required.

**Method of Payment.** Unless otherwise specified, the price per unit of work or lump sum item shall include all engineering, labor, personnel, equipment, materials, etc.,

necessary to complete that unit of work. Failure to follow the procedures as stated will result in non-payment of the unit price item. The most current ASTM or AASHTO test procedure and supporting tests referenced shall be used. The units of work are defined as follows:

1. **Soil Classification.** Soil Classification includes gradation and plasticity index and shall be paid for at a unit price per sample. This charge item includes all testing, calculation of Atterberg limits and all related indices, i.e. liquidity index and classification. Samples for soil mechanics and foundation analysis testing shall be performed according to ASTM D 4318 and D 422 test procedures on each sample. Samples for roadway testing shall be performed according to AASHTO T87, T88, T89, and T90 test procedures for each sample. If a hydrometer analysis is needed, it will be paid for under charge item 6A.
2. **Moisture Content.** Moisture Content shall be paid for at a unit price per test. This charge item shall include all operations and materials necessary to obtain the sample and perform the test according to ASTM D 2216 and AASHTO T 265. Moisture content required for other tests such as unconfined compression, etc. will be reimbursed under those test costs and will not be paid for under this item.
3. **Specific Gravity.** Specific Gravity shall be paid for at a unit price per test. This charge item shall include all operations and materials necessary to perform the test according to ASTM 854 and AASHTO T 100.
4. **Chunk Density.** Chunk Density shall be paid for at a unit price per test. This charge item shall include all operations and materials necessary to perform the test according to AASHTO T233.
5. **pH test.** pH test shall be paid for at a unit price per test. This charge item shall include all operations and materials necessary to perform the test according to the ASTM D 4972 and AASHTO T289.
6. **Hydrometer, Double Hydrometer or Pin Hole Tests.** Hydrometer or Pin Hole Test shall be paid for at a unit price per test. These charge items shall include all operations and materials necessary to perform each test according to AASHTO T 88, ASTM D 422, D 4221 or ASTM D 4647, respectively.
7. **Electrical Resistivity Test.** Electrical Resistivity Test shall be paid for at a unit price per test. This charge item includes all operations and materials necessary to perform the test sample preparation according to AASHTO T

- 289 and testing according to ASTM G 57 for bridges, or to perform the test sample preparation and testing according to AASHTO T 288 for roadway.
8. **Soluble Sulfate Test.** Soluble Sulfate Test shall be paid for at a unit price per test. This charge item includes all operations and materials necessary to perform this test according to the OHD L-49 procedures which can be found on the ODOT, Materials Division website.  
<http://www.okladot.state.ok.us/materials/materials.htm>
  9. **Slake Durability Test.** Slake Durability Test shall be paid for at a unit price per test. This charge item shall include all operations and materials necessary to perform this test according to ASTM D 4644.
  10. **Unconfined Compression Test.** Unconfined Compression Test shall be paid for at a unit price per test. This charge item shall include all operations and materials necessary for preparation of samples and to perform this test for soil and rock. Preparation and tolerances for rock specimens shall be in accordance with ASTM D 4543 requirements.
    - A. UC test of soil and rock according to ASTM D 2166 and ASTM D 2938, respectively.
    - B. Uniaxial compression test of intact rock core specimens with axial strain measurement and corresponding Intact Rock Modulus according to ASTM D 3148. The use of linear variable differential transformers (LVDTs) meeting the precision requirements of ASTM D 3148 is acceptable.
  11. **Point Load Test.** Point Load Test shall be paid for at a unit price per specimen. This charge item shall include all operations and materials necessary to perform this test in accordance with ASTM D 5731.
  12. **Moisture-Density Test.** Moisture-Density Test shall be paid for at a unit price per test. This charge item shall include all operations and materials necessary to perform the tests according to AASHTO T 99 Methods A, B, C and D; AASHTO T-180 Methods, A, B, C and D; ASTM D 698 Procedures A, B, and C; and ASTM D 1557 Procedures A, B, and C. Each test will include a minimum of five (5) moisture/density points.
  13. **One-Dimensional Consolidation Test.** One-Dimensional Consolidation Test shall be paid for at a unit price per test. This charge item shall include all



operations and materials necessary to perform this test according to ASTM D 2435.

14. **Drained Direct Shear Test.** Drained Direct Shear Test shall be paid for at a unit price per test for cohesionless soil and cohesive soils, respectively. These charge items shall include all operations and materials necessary to perform this test according to ASTM D 3080. Each test will include a minimum of three (3) points.
15. **Triaxial Shear.** Triaxial Shear Test shall be paid for at a unit price per test for unconsolidated undrained and consolidated drained with pore pressure measurement, respectively. These charge items shall include all operations and materials necessary to perform this test according to ASTM D 2850 and D 4767. Each test will include a minimum of three (3) points.
16. **Resilient Modulus Test.** Resilient Modulus Test shall be paid for at a unit price per test. This charge item shall include all operations and materials necessary to perform the test according to AASHTO T 307.
17. **Swell and Swell Pressure Test.** Swell and Swell Pressure Test shall be paid for at a unit price per test. This charge item shall include all operations and materials necessary to perform this test according to ASTM D 4546.
18. **Geotechnical Drilling.** Geotechnical Drilling shall be paid from top of ground to bottom of the hole at a unit price per foot for soil, soft rock and shale, and hard rock, respectively. These charge items shall include all operations and materials necessary to advance the hole. This includes borings for sampling and testing by means of the Standard Penetration Test split spoon sampler, thin-walled tube sampler, and the Texas Cone Penetrometer. Sampling techniques shall be performed according to ASTM D 1586 and D 1587 respectively. Hard rock coring shall be performed in accordance with ASTM D 2113.
19. **Standard Penetration Test.** Standard Penetration Test shall be paid for at a unit price per test. This charge item shall include all operations and materials necessary to perform the test according to ASTM D 1586.
20. **Texas Cone Penetration Test, TCPT.** Texas Cone Penetration Test shall be paid for at a unit price per test. This charge item shall include all operations and materials necessary to perform the test as outlined in the Specifications for Geotechnical Investigation.

21. **Dynamic Cone Penetration Test, DCPT.** Dynamic Cone Penetration Test shall be paid for at a unit price per test. This charge item shall include all operations and materials necessary to perform the test according to ASTM D 6951.
  
22. **Thin-Walled Tube Sample.** Thin-Walled Tube sampling shall be paid for at a unit price per sample. This charge item shall include all operations and materials necessary to perform the test according to ASTM D 1587.

23. **Mechanical and Electrical Friction Cone and Piezocone, Penetration Testing of Soils.** Mechanical and Electrical Friction Cone and Piezocone, Penetration Testing of Soils shall be paid from top of ground to the depth at refusal at a unit price per foot of cone advancement. This charge item shall include all operations and materials necessary to perform this test according to ASTM D 3441 and D 5778.
24. **Pressuremeter Test.** Pressuremeter Test shall be paid for at a unit price per test. This charge item includes all operations and materials necessary to perform the test according to ASTM D 4719.
25. **Dilatometer Test.** Dilatometer Test shall be paid for at a unit price per test. This charge item shall include all operations and materials necessary to perform the test according to ASTM D 6635.
26. **Seismic Test.** Seismic Test shall be paid for at a unit price per shot point along each survey spread. This charge item includes all operations and materials necessary to perform seismic tests according to the following criteria:
  - A. (A. & B.)  
Engineering Surveys to accurately profile geologic layers (bedrock and/or water table) and to determine depths to layers. For engineering surveys, at least five (5) shot points per spread are required with a forward, reverse, beyond end shots, and at least one (1) intermediate shot. Shot points and geophones will be surveyed for vertical and horizontal control. Short geophone spacing and sufficient number of shot points will be required to achieve overlapping reciprocal arrivals necessary for accurate depth to refractor determination.
  - B. (B. & C.)  
Rippability Surveys to determine seismic velocities for rippability assessment. For rippability surveys, at least two (2) shot points per spread are required with a forward and reverse shot. If bore hole data is not available to establish a geological profile, more rigorous field procedures described above for Engineering Surveys will be required to profile geologic layers.
27. **Monitoring Well.** Monitoring Well shall be paid for at unit price per foot of well installed. This charge item shall include all operations and materials necessary to install monitoring wells according to ASTM D 5092. Monitoring wells shall include a locking protective cover, and be constructed of 2" minimum ID PVC flush thread casing with factory slotted PVC screen. The

- unit price does not include drilling. Drilling shall be paid for at the contract unit price for Geotechnical Drilling. The unit price includes development of the well, and a water table reading after completion of the well according to ASTM D 4750.
28. **Field Permeability Test.** Field Permeability Test shall be paid for at a unit price per test. This charge item shall include all operations and materials necessary to perform this test according to procedure identified in the AASHTO Manual Subsurface Investigations, Subsection B.6.3 as either a falling head, constant head or rising head test with further reference to Hvorslev (1951).
  29. **Water Sampling and Testing.** Water Sampling and Testing shall be paid for at a unit price per test. This charge item shall include all operations and materials necessary to perform the sampling and testing outlined in the Specifications for Geotechnical Investigation.
  30. **Hole Abandonment.** Hole Abandonment shall be paid for at a unit price per foot for borings that penetrate the groundwater table. This charge item includes all operations and materials necessary to decommission boreholes according to the most current specifications: AASHTO R-22 and Specifications 785:35-11-2 of the Oklahoma Water Resources Board Requisitions. The unit price includes abandonment and decommissioning of geotechnical exploratory boreholes and monitoring wells.
  31. **Dozer Working Time.** Dozer Working Time (including operator) shall be paid for at a unit per hour of dozer working time. Mobilization (includes demobilization) costs for the dozer and operation shall be paid at the hourly rate for a maximum of four (4) hours for each project.
  32. **Traffic Control.** Traffic Control shall be paid for as a lump sum for mobilization and a unit rate per day. This charge item includes all operations and materials necessary to perform traffic control according to Chapter IV of the Manual on Uniform Traffic Control Devices when performing testing and investigative operations on mainline paving such as FWD testing, pavement coring, and in-place subgrade sampling of existing pavement sections. Charges for this work must be negotiated for each task order.
  33. **TowBoat/Barge.** Towboat/Barge and its crew shall be paid as a lump sum for mobilization and unit rate per day. Charges for this work must be negotiated for each task order.

34. **Mobilization of Equipment.** Mobilization of Equipment shall be paid for at unit price per mile. Round trip mileage shall be computed from Oklahoma City, Tulsa, or the actual location of equipment, whichever is less. This includes mobilization and demobilization of all equipment necessary to perform the subsurface investigation.
35. **Engineering.** Engineering shall be paid for at a unit price per hour. This charge item includes all operations and materials necessary to perform Engineering Analyses as outlined below in items A-C. It also includes all items and operations necessary for preparing and writing reports, drafting, making recommendations and other correspondence.
- A. **Slope Stability Analyses.** Each analysis shall reference the analysis method and software used and include the accompanying factor of safety obtained
- B. **Settlement Analyses.** Each analysis shall include ultimate settlement and time rate of settlement calculations. In the case of spread footings, the analysis shall include all calculations necessary to size the footing. Analyses shall be presented in the form of a drawing to show the embankment or footing, the soil layers, parameters and all the calculations. Surcharge loading and/or wick drain analyses shall also be considered where applicable.
- C. **Seismic Analyses.** Several hand methods and computer modeling programs are available for refraction analysis. If significant surface or bedrock relief is present, computer analysis will be required. If hand methods are used, at least two different methods shall be used with one method being the "Delayed Time" method. For Engineering Surveys, velocities of each layer and geologic profile with depths to each layer under every shot point and geophone shall be determined. For Rippability Surveys, velocities of each layer and a general geologic profile shall be determined. An assessment of rippability shall be presented.
- D. **Report Preparation.** As a minimum, each report will address those items required in the most current ODOT Geotechnical Specifications. Activities under this item include boring location plan preparation, drafting of boring location plan, and writing and typing the text of the report.
- E. **Miscellaneous Analysis.** This item is for other analyses not specifically outlined above. The unit price shall be on an hourly basis. The scope of the specific analysis will be included in each task order.

36. **Miscellaneous Labor, Materials and Equipment as required to meet Section 404 Requirements.** Miscellaneous Labor, Materials and Equipment as required to meet Section 404 Requirements shall be paid for on a lump sum basis. This charge item shall include all miscellaneous labor, materials, and equipment necessary to complete the work, i.e., erosion control measures such as hay bales. Charges for this work must be negotiated for each task order.
37. **Pavement Deflection Testing, Pavement Evaluation and Pavement Coring.** Pavement Deflection Testing, Pavement Evaluation, Ground Penetrating Radar (GPR), and Pavement Coring shall be paid for under items for mobilization/use of equipment, pavement coring, distress identification, GPR, and deflection testing. Traffic Control will be paid for under item 31. Mobilization/use of pavement coring equipment shall be paid for at a unit price per day. Mobilization/use of distress identification equipment, GPR equipment, and deflection testing equipment (FWD) shall be paid on a unit rate basis. Charges for this work must be reviewed and approved by ODOT prior to performing any work associated with this item. Pavement Coring shall be paid for at a unit price for asphalt pavement cores and unit price for concrete cores. Composite Cores shall be paid for at a unit price for Concrete Cores. This includes all operations and materials to cut 4 or 6 inch (100 or 150mm) diameter cores and repair core holes. Concrete pavement shall be repaired with grout and asphalt pavement shall be repaired with cold patch. Distress Identification shall be based on 10% sampling and shall identify distress types and severities as detailed in the FHWA Publication No. FHWA-RD-03-031 "Distress Identification Manual for the Long Term Pavement Performance Program". Distress Identification, GPR testing, FWD testing and data analysis including the identification of uniform sections and back calculations of pavement layer moduli using the latest version of Modulus and/or AASHTO, shall be paid as for each Lane-Mile tested.
38. **Site Access.** Site Access shall be paid at a unit price per hour while someone is on site for purposes such as securing access to private property or obtaining water level readings in a previously completed monitoring well. There shall also be a unit price per mile which includes travel time and vehicle mileage costs. Round trip mileage shall be computed from Oklahoma City, Tulsa, or the actual location of personnel whichever is less.
39. **Pedological Research/Assessment.** Pedological Research/Assessment shall be paid at a unit price per hour. This item is for a "Desk Top" evaluation of mapped soils and units crossed by the proposed alignment. Work under this item includes plotting the proposed alignment on the County Soil survey map and determining which mapped units will be crossed. The NRCS

national database is to be used as a resource in obtaining the most current soil series descriptions.

40. **Survey for New Alignment Borings.** Surveys to locate geotechnical borings for projects on new alignment shall be paid as a lump sum and will be negotiated for each task order. The survey coordinates shall be referenced to plan stations and elevations.

**OKLAHOMA DEPARTMENT OF TRANSPORTATION  
ENGINEERING CONTRACT: EC- [REDACTED]  
ATTACHMENT A9  
SURVEY SPECIAL PROVISION**



**OKLAHOMA DEPARTMENT OF TRANSPORTATION  
ENGINEERING CONTRACT NO. EC-  
ATTACHMENT B1  
KEY PERSONNEL**

*(Prime and Applicable 1<sup>st</sup> Tier Sub)*

Name, Telephone Number, Fax, Cell Phone Number and E-Mail Address	Key Personnel Classification	Performance Characteristics (Job Description)	Primary Location Where Work Will Be Completed (Physical Address)

Changes must be approved by the Department.

**OKLAHOMA DEPARTMENT OF TRANSPORTATION  
ENGINEERING CONTRACT NO. EC-  
ATTACHMENT B2  
SUB-CONSULTANT PARTICIPATION**

*(Prime Only)*

<b>FIRST TIER SUB-CONSULTANT PARTICIPATION</b>					
The table presents the following sub-consultant participants in this offer and any resulting contract.					
Name of Business Address where work will be performed	Type of Work to be performed, Project Component, Job Piece No., Project Component Job No.	Estimated Fees	Method of Compensation	Local Business (Y or N)	DBE (Y or N)

Submitted by: \_\_\_\_\_

Date: \_\_\_\_\_

Total Contract Value: \_\_\_\_\_

D.B.E. Goal: \_\_\_\_\_

**OKLAHOMA DEPARTMENT OF TRANSPORTATION  
ENGINEERING CONTRACT NO. EC-  
ATTACHMENT B3  
APPROVED HOURLY AND OVERHEAD RATES**

*(Prime and Applicable 1<sup>st</sup> Tier Sub on Hourly Contracts Only)*

<b>Personnel Classification</b>	<b>Average Hourly Wage Rate</b>	<b>Approved Rate Multiplier</b>	<b>Approved Hourly Rate</b>

**OKLAHOMA DEPARTMENT OF TRANSPORTATION  
ENGINEERING CONTRACT NO. EC-  
ATTACHMENT C  
TASK ORDER REQUIREMENTS AND PROCEDURES**

The purpose of a Task Order is to supplement the basic Contract and to provide a vehicle to communicate, define, approve, authorize the scope of services, schedule, fees, provide funding and other parameters related to services to be provided by the Consultant. All efforts which are the Consultant's responsibility and for which the Consultant expects to be compensated must be defined in an approved Task Order if applicable. Services provided by the Consultant which have not been included in an approved Task Order or modified Task Order will be considered gratuitous and the Department will not be obligated to compensate the Consultant for such services.

The Department, in writing through a Request for Services, will initiate Task Orders. Upon receipt of a written Request for Services and prior to preparing a Task Order, the Consultant and the Department will discuss the services to be provided under the proposed Task Order and agree generally that the instructions are clearly stated and understood. Following this verbal concurrence, Task Order development may be initiated.

**SECTION 1: REQUEST FOR SERVICES DEVELOPMENT**

- 1.1 Request for Services – When the Department determines there is a need for the services of the Consultant; a Request for Services will be prepared. The Request for Services will include the following:
  - 1.1.1 Task Order Number, Project Description, County and Job Piece Number.
  - 1.1.2 Proposed Method of Compensation.
  - 1.1.3 A general description of services to be provided through the requested Task Order.
  - 1.1.4 A general description of the anticipated deliverables.
  - 1.1.5 A schedule to complete the requested services.

**SECTION 2: TASK ORDER DEVELOPMENT**

- 2.1 Request for Task Order Approval – Upon receipt of a written Request for Services and as further instructed by the Department, the Consultant would prepare a Request for Task Order Approval. The purpose of the Request for Task Order Approval is to establish specifically and in a detailed format the

services to be provided, technical standards, schedule, compensation, and other parameters under which the work is to be completed.

- 2.1.1 Each Request for Task Order Approval must include the following:
  - 2.1.1.1 Task Order Number, Project Description, County and Job Piece Number.
  - 2.1.1.2 Consultant name and Contract Number.
  - 2.1.1.3 Detailed, definitive, and specific scope of services including project limits (if applicable) for services to be provided.
  - 2.1.1.4 Method of Compensation and budget for the requested Task Order.
  - 2.1.1.5 Man-hour detail including a list of tasks to be accomplished, personnel classifications, and hourly rates, overhead, other direct expenses, and fees.
  - 2.1.1.6 List of deliverables, if applicable.
  - 2.1.1.7 Schedule for completing scope of services including all reviews and approvals by others.
  - 2.1.1.8 Project Manager/Engineer and/or Key Personnel to be assigned to the project and location where work will be completed.
  - 2.1.1.9 Completed First Tier Sub-Consultant Participation form as provided in Attachment B2.
  - 2.1.1.10 Signature of Consultant and the date of submittal.
  - 2.1.1.11 A signature Block for subsequent use by the Department in the execution and recording of the date of Task Order Approval.

**SECTION 3: TASK ORDER APPROVAL**

- 3.1 The following process will be followed in reviewing and approving Request for Task Order Approval applications.
  - 3.1.1 The Consultant will submit the Request for Task Order Approval to the Department for review. The Department shall review the Request for

Task Order Approval to determine that it accurately and definitively describes the services to be provided; work to be completed; deliverables; compensation and method of payment; and, if applicable, the project limits.

- 3.1.2 Should it be determined that one or more elements of the Request for Task Order Approval are not approved by the Department, such elements shall be brought to the attention of the Consultant. Efforts will be made to negotiate an approval of the elements in question.
- 3.1.3 After negotiations if it is determined that resolution cannot be achieved, the Department may elect to continue negotiations or elect to complete the work using its own forces or the services of others.
- 3.1.4 Within ten (10) working days after a Request for Task Order Approval is received, the Department will either notify the Consultant that the Task Order will be approved; identify elements which do not meet with the approval of the Department and are to be considered for negotiation; notify the Consultant that the Task Order is not being approved; or notify the Consultant that the Request for Task Order Approval is being held for future consideration.
- 3.1.5 Upon approval of a proposed Task Order, the Department and the Consultant will execute the Task Order document thereby signifying acceptance of the specific terms and exemplified provisions therein and acknowledging the formality of this Contract.
- 3.1.6 The Department will forward the executed Task Order to the Project Management Division for further processing and the issuance of a Task Order Contract No. and an associated Notice to Proceed.

**OKLAHOMA DEPARTMENT OF TRANSPORTATION  
ENGINEERING CONTRACT NO. EC-  
ATTACHMENT D1  
US DOT CERTIFICATION FOR FEDERAL-AID CONTRACTS**

The Prospective Participant, \_\_\_\_\_, (Consultant), certifies, by signing and submitting this bid or proposal, to the best of his or her knowledge and belief, that:

1. No federal appropriated funds have been paid or will be paid, by or on behalf of the undersigned, to any person for influencing or attempting to influence an officer or employee of any federal agency, a member of Congress, an officer or employee of Congress, or an employee of a member of Congress in connection with the awarding of any federal contract, the making of any federal grant, the making of any federal loan, the entering into of any cooperative contract, and the extension, continuation, renewal, amendment, or modification of any federal contract, grant, loan, or cooperative contract.
2. If any funds other than federal appropriated funds have been paid or will be paid to any person for influencing or attempting to influence an officer or employee of any federal agency, a member of Congress, an officer or employee of Congress, or an employee of a member of Congress in connection with this federal contract, grant, loan, or cooperative contract, the undersigned shall complete and submit Standard Form-LLL, "Disclosure Form to Report lobbying", in accordance with its instructions.
3. The consultant shall require that the language of this certification be included in the award documents for all sub-awards at all tiers (including sub-contracts, sub-grants, and contracts under grants, loans, and cooperative agreements) and that all sub-recipients shall certify and disclose accordingly..

This certification is a material representation of fact upon which reliance was placed when this transaction was made or entered into. Submission of this certification is a prerequisite for making or entering into this transaction imposed by Section 1352, Title 31, US Code. Any person who fails to file the required certification shall be subject to a civil penalty of not less than \$10,000 and not more than \$100,000 for each failure.

**OKLAHOMA DEPARTMENT OF TRANSPORTATION  
ENGINEERING CONTRACT NO. EC-  
ATTACHMENT D2  
US DOT CERTIFICATION OF ELIGIBILITY**

The Prospective Participant, \_\_\_\_\_, (Consultant), certifies, by signing and submitting this bid or proposal, to the best of his or her knowledge and belief, states:

- a) That he or she is the Prospective Participant or fully authorized agent of the Prospective Participant in this project which involves federal funding, and has full knowledge and authority to make this certification.
  
- b) That, except as noted below, \_\_\_\_\_  
(Prospective Participant)  
or any person associated therewith in the capacity of owner, partner, director, officer, principal investigator, project director, manager, auditor or accountant, project superintendent, or any person in a position involving the administration of federal funds:
  - a. Is not currently under suspension, debarment, voluntary exclusion, or determination of ineligibility by any federal agency; and
  - b. has not been suspended, debarred, voluntarily excluded or determined ineligible by any federal agency within the past three (3) years; and
  - c. does not have a proposed debarment pending; and
  - d. has not had any public transaction (federal, state, or local) terminated within the preceding three (3) years for cause or default; and
  - e. has not been indicted, convicted, or had a civil judgment rendered against any of the aforementioned by a court of competent jurisdiction in any matter involving fraud or official misconduct within the past three (3) years, except:

\_\_\_\_\_

**(IF NONE, SO STATE BY ENTERING THE WORD NONE)**. For any exception noted, indicate on the reverse side of this page to whom it applies, initiating agency, and dates of action. Providing false information may result in criminal prosecution or administrative sanctions.



**OKLAHOMA DEPARTMENT OF TRANSPORTATION  
ENGINEERING CONTRACT NO. EC-  
ATTACHMENT D3  
TITLE VI OF THE CIVIL RIGHTS ACT OF 1964  
ASSURANCES**

, (hereinafter referred to as the Consultant) HEREBY AGREES THAT, as a condition to receiving any federal financial assistance from the Department of Transportation, it will comply with Title VI of the Civil Rights Act of 1964, 78 Stat. 252, 42 U.S.C. 2000d to 42 U.S.C. 2000d-4 (hereinafter referred to as the Act), and all requirements imposed by or pursuant to Title 49, Code of Federal Regulations, Department of Transportation, Subtitle A, Office of the Secretary, Part 21, Nondiscrimination in Federally-assisted Programs of the Department of Transportation-Effectuation of Title VI of the Civil Rights Act of 1964 (hereinafter referred to as the Regulations), and other pertinent directives to the end that, in accordance with the Act, regulations, and other pertinent directives, no person in the United States shall, on the grounds of race, color, sex, age, national origin, disability/handicap, or income status, be excluded from participation in, be denied the benefits of, or be otherwise subjected to discrimination under any program or activity for which the Consultant receives Federal financial assistance from the Department of Transportation, including the Federal Highway Administration; and HEREBY GIVES ASSURANCE THAT it will promptly take any measures necessary to effectuate this agreement. This assurance is required by Subsection 21.7(a) (1) of the Regulations, a copy of which is attached.

More specifically and without limiting the above general assurance, the Consultant hereby gives the following specific assurances with respect to its Federal-aid Highway Program:

1. That the Consultant agrees that each "program" and each "facility," as defined in Subsections 21.23(e) and 21.23(b) of the Regulations, will be (with regard to a "program") conducted or will be (with regard to a "facility") operated in compliance with all requirements imposed by or pursuant to the Regulations.
2. That the Consultant shall insert the following notification in all solicitations for bids for work or materials subject to the regulations made in connection with the Federal-aid Highway Program and, in adapted form, in all proposals for negotiated agreements:

, in accordance with Title VI of the Civil Rights Act of 1964, 78 Stat. 252, 42 U.S.C. 2000d to 2000d-4, and Title 49, Code of Federal Regulations, Department of Transportation, Subtitle A, Office of the Secretary, Part 21, Nondiscrimination in Federally-assisted Programs of the Department of Transportation, issued pursuant to such Act, hereby notifies all bidders that it will affirmatively ensure that in any contract entered into pursuant to this advertisement, Disadvantaged Business Enterprises will be afforded full

opportunity to submit bids in response to this invitation and will not be discriminated against on the grounds of race, color, sex, age, national origin, disability/handicap, or income status in consideration for an award.

3. That the Consultant shall insert the clauses of Appendix A of this assurance in every contract subject to the Act and the Regulations.
4. That the clauses of Appendix B of this assurance shall be included, as a covenant running with the land, in any deed from the United States effecting a transfer of real property, structures, or improvements thereon, or interest therein.
5. That where the Consultant receives federal financial assistance to construct a facility or part of a facility, the assurance shall extend to the entire facility and facilities operated in connection therewith.
6. That where the Consultant receives federal financial assistance in the form, or for the acquisition of real property or an interest in real property, the assurance shall extend to rights to space on, over, or under such property.
7. That the Consultant shall include the appropriate clauses set forth in Appendix C of this assurance, as a covenant running with the land, in any future deeds, leases, permits, licenses, and similar agreements entered into by the Consultant with other parties (a) for the subsequent transfer of real property acquired or improved under the Federal-aid Highway Program; and (b) for the construction or use of, or access to space on, over, or under, real property acquired or improved under the Federal-aid Highway Program.
8. That this assurance obligates the Consultant for the period during which Federal financial assistance is extended to the program, except where the Federal financial assistance is to provide, or is in the form of, personal property, or real property or interest therein, or structures or improvements thereon; in which case the assurance obligates the Consultant or any transferee for the longer of the following periods: (a) the period during which the property used for a purpose for which the Federal financial assistance is extended, or for another purpose involving the provision of similar services or benefits; of (b) the period during which the Consultant retains ownership or possession of the property.
9. The Consultant shall provide for such methods of administration for the program as are found by the Secretary of Transportation, or the official to whom he or she delegates specific authority, to give reasonable guarantee that it, other recipients, sub-grantees, contractors, sub-contractors, transferees, successors in interest; and other participants of federal financial assistance under such program will comply with all requirements imposed by or pursuant to the Act, the Regulations, and this assurance.

10. The Consultant agrees that the United States has a right to seek judicial enforcement with regard to any matter arising under the Act, the Regulations, and this assurance.

THIS ASSURANCE is given in consideration of and for the purpose of obtaining any and all federal grants, loans, contracts, property, discounts, or other federal financial assistance extended after the date hereof to the Consultant by the Department of Transportation under the federal-aid Highway Program and is binding on it, other recipients, sub-grantees, contractors, sub-contractors, transferees, successors in interest, and other participants in the federal-aid Highway Program. The person or persons whose signatures appear below are authorized to sign this assurance on behalf of the Consultant.

\_\_\_\_\_  
Signature of Authorized Official

\_\_\_\_\_  
Date

Attachments:  
Appendices A, B, and C

**APPENDIX A**

During the performance of this Contract, the Consultant, for itself, its assignees, and successors in interest, agrees as follows:

**1. Compliance with Regulations:**

The Consultant shall comply with the regulations relative to nondiscrimination in federally-assisted programs of the Department of Transportation, Title 49, Code of Federal Regulations, Part 21, as they may be amended from time to time (hereinafter referred to as the Regulations), which are herein incorporated by reference and made a part of this Contract.

**2. Nondiscrimination:**

The Consultant, with regard to the work performed by it during the Contract, shall not discriminate on the grounds of race, color, sex, age, national origin, disability/handicap, or income status, in the selection and retention of sub-contractors, including procurements of materials and leases of equipment. The Consultant shall not participate, either directly or indirectly, in the discrimination prohibited by Section 21.5 of the Regulations, including employment practices when the contract covers a program set forth in Appendix B of the Regulations.

**3. Solicitations for Sub-contracts, Including Procurement of Materials and Equipment:**

In all solicitations, either by competitive bidding or negotiation, made by the Consultant for work to be performed under a sub-contract, including procurements of materials or leases of equipment, each potential sub-contractor or supplier shall be notified by the Consultant of the Consultant's obligations under this Contract and the Regulations relative to nondiscrimination on the grounds of race, color, sex, age, national origin, disability/handicap, or income status.

**4. Information and Reports:**

The Consultant shall provide all information and reports required by the Regulations, or directives issued pursuant thereto, and shall permit access to its books, records, accounts, other sources of information and its facilities as may be determined by the State Department of Transportation or the Federal Highway Administration to be pertinent to ascertain compliance with such Regulations or directives. Where any information required of a Consultant is in the exclusive possession of another who fails or refuses to furnish this information, the Consultant shall so certify to the State Department of Transportation, or the Federal Highway Administration, as appropriate, and shall set forth what efforts it has made to obtain the information.

**5. Sanctions for Noncompliance:**

In the event of the Consultant's noncompliance with the nondiscrimination provision of this Contract, the State Department of Transportation shall impose such Contract sanctions as it or the Federal Highway Administration may determine to be appropriate, including but not limited to:

- a. Withholding of payments to the Consultant under the Contract until the Consultant complies and/or
- b. Cancellation, termination, or suspension of the Contract in whole or in part.

6. **Incorporation of Provisions:**

The Consultant shall include the provisions of paragraphs 1 through 6 in every sub-contract, including procurements of materials and leases of equipment, unless exempt by the Regulations or directives issued pursuant thereto. The Consultant shall take such action with respect to any sub-contract or procurement as the State Department of Transportation or the Federal Highway Administration may direct as a means of enforcing such provisions, including sanctions for noncompliance provided, however, that in the event a Consultant becomes involved in, or is threatened with, litigation by a sub-contractor or supplier as a result of such direction, the Consultant may request the State Department of Transportation to enter into such litigation to protect the interests of the State; and, in addition, the Consultant may request the United States to enter into such litigation to protect the interests of the United States.

**APPENDIX B**

The following clauses shall be included in any and all deeds effecting or recording the transfer of real property, structures, or improvements thereon, or interest therein from the United States.

**(GRANTING CLAUSE)**

NOW, THEREFORE, the Department of Transportation, as authorized by law and upon the condition that the State of Oklahoma will accept title to the lands and maintain the project constructed thereon in accordance with Title 23, United States Code, the Regulations for the Administration of Federal Aid for Highways, and the policies and procedures prescribed by the Federal Highway Administration of the Department of Transportation, and also in accordance with and in compliance with all requirements imposed by or pursuant to Title 49, Code of Federal Regulations, Department of Transportation, Subtitle A, Office of the Secretary, Part 21, Nondiscrimination in Federally-assisted Programs of the Department of Transportation (hereinafter referred to as the Regulations), pertaining to and effectuating the provisions of Title VI of the Civil Rights Act of 1964 (78 Stat.252; 42 U.S.C. 2000d to 2000d-4), does hereby remise, release, quitclaim, and convey unto the State of Oklahoma all the right, title, and interest of the Department of Transportation in and to said lands described in Exhibit "A" attached hereto and made a part hereof.

**(HABENDUM CLAUSE)**

TO HAVE AND TO HOLD said lands and interests therein unto the State of Oklahoma and its successors forever subject however, to the covenant, conditions, restrictions, and reservations herein contained as follows, which will remain in effect for the period during which the real property or structures are used for a purpose for which federal financial assistance is extended, or for another purpose involving the provision of similar services or benefits, and shall be binding to the State of Oklahoma, its successors, and assigns.

The State of Oklahoma, in consideration of the conveyance of said lands and interests in lands, does hereby covenant and agree, as a covenant running with the land, for itself, its successor, and assigns that (1) no person shall, on the grounds of race, color, sex, age, national origin, disability/handicap, or income status, be excluded from participation in, be denied the benefits of, or be otherwise subjected to discrimination with regard to any facility located wholly or in part on, over, or under such lands hereby conveyed [,][and]\* (2) that the State of Oklahoma shall use the lands and interests in lands so conveyed in compliance with all requirements imposed by or pursuant to Title 49, Code of Federal Regulations, Department of Transportation, Subtitle A, Office of the Secretary, Part 21, Nondiscrimination in Federally-assisted Programs of the Department of Transportation-Effectuation of Title VI of the Civil Rights of 1964, and as said Regulations may be amended [,] and (3) that in the event of breach of any of the above-mentioned nondiscrimination conditions, the Department shall have a right to re-

enter said lands and facilities on said land; and the above described land and facilities shall thereon revert to and vest in and become the absolute property of the Department of Transportation and its assignees as such interest existed prior to the deed.\*

\*Reverter clause and related language to be used only when it is determined that such a clause is necessary in order to effectuate the purposes of Title VI of the Civil Rights Act of 1964.

**APPENDIX C**

The following clauses shall be included in all deeds, licenses, leases, permits, or similar instruments entered into by the State of Oklahoma, pursuant to the provisions of Assurance 7(a).

The (grantee, licensee, lessee, permittee, etc., as appropriate), for him or herself, his or her heirs, personal representative, successors in interest, and assigns, as a part of the consideration hereof, does hereby covenant and agree [in the case of deeds and leases add “as a covenant running with the land”] that in the event facilities are constructed, maintained, or otherwise operated on the said property described in this (deed, license, lease, permit, etc.) for a purpose for which a Department of Transportation program or activity is extended, or for another purpose involving the provision of similar services or benefits, the (grantee, licensee, lessee, permittee, etc.) shall maintain and operate such facilities and services in compliance with all other requirements imposed pursuant to Title 49, Code of Federal Regulations, Department of Transportation, Subtitle A, Office of the Secretary, Part 21, Nondiscrimination in federally-assisted Programs of the Department of Transportation-Effectuation of Title VI of the Civil Rights Act of 1964, and as said Regulations may be amended.

[Include in licenses, leases, permits, etc.]\*

That in the event of breach of any of the above nondiscrimination covenants, the State of Oklahoma shall have the right to terminate the [license, lease, permit, etc.] and to re-enter and repossess said land and the facilities thereon and hold the same as if said [license, lease, permit, etc.] had never been made or issued.

[Include in deeds]\*

That in the event of breach of any of the above nondiscrimination covenants, the State of Oklahoma shall have the right to re-enter said lands and facilities thereon, and the above described lands and facilities shall thereupon revert to and vest in and become the absolute property of the State of Oklahoma and its assigns.

\*Reverter clause and related language to be used only when it is determined that such a clause is necessary in order to effectuate the purposes of Title VI of the Civil Rights Act of 1964.

The following shall be included in all deeds, licenses, leases, permits, or similar agreements entered into by the State of Oklahoma, pursuant to the provisions of Assurance 6(b).

The (grantee, licensee, lessee, permittee, etc., as appropriate), for him or herself, his or her personal representatives, successors in interest, and assigns, as a part of the consideration hereof, does hereby covenant and agree [in the case of deeds and leases add “as a covenant running with the land”] that (1) no person, on the grounds of



race, color, sex, age, national origin, disability/handicap, or income status, shall be excluded from participation in, be denied the benefits of, or be otherwise subjected to discrimination in the use of said facilities, (2) that in the construction of any improvements on, over, or under such land and the furnishing of services thereon, no person, on the grounds of race, color, sex, age, national origin, disability/handicap, or income status, shall be excluded from participation in, be denied the benefits of, or otherwise be subjected to discrimination, 93) that the (grantee, licensee, lessee, permittee, etc.) shall use the premises in compliance with all other requirements imposed by or pursuant to Title 49, Code of Federal Regulations, Department of Transportation, Subtitle A, Office of the Secretary, Part 21, Nondiscrimination in Federally-assisted Programs of the Department of Transportation-Effectuation of Title VI of the Civil Rights Act of 1964, and as said Regulations may be amended.

[Include in licenses, leases, permits, etc.]\*

That in the event of breach of any of the above nondiscrimination covenants, the State of Oklahoma shall have the right to terminate the [license, lease, permit, etc.] and to re-enter and repossess said land and the facilities thereon and hold the same as if said [license, lease, permit, etc.] had never been made or issued.

[Include in deeds]\*

That in the event of breach of any of the above nondiscrimination covenants, the State of Oklahoma shall have the right to re-enter said land and facilities thereon, and the above described lands and facilities shall thereupon revert to and vest in and become the absolute property of the State of Oklahoma and its assigns.

Reverter clause and related language to be used only when it is determined that such a clause is necessary in order to effectuate the purpose of Title VI of the Civil Rights Act of 1964.

**OKLAHOMA DEPARTMENT OF TRANSPORTATION  
ENGINEERING CONTRACT NO. EC-  
ATTACHMENT D4  
DRUG FREE WORKPLACE**

1. The Consultant, \_\_\_\_\_, certifies that (s)he will continue to provide a drug free workplace by:
  - a. Publishing a statement notifying employees that the unlawful manufacture, distribution, dispensing, possession or use of a controlled substance is prohibited in the Consultant's workplace and specifying the actions that will be taken against employees for violation of such prohibition;
  - b. Establishing an ongoing drug free awareness program to inform employees about:
    - i. The dangers of drug abuse in the workplace;
    - ii. The Consultant's policy of maintaining a drug free workplace;
    - iii. Any available drug counseling, rehabilitation and employee assistance programs; and
    - iv. The penalties that may be imposed upon employees for drug abuse violations occurring in the workplace;
  - c. Making it a requirement that each employee that will be engaged in the performance of the project be given a copy of the statement required by paragraph a;
  - d. As a condition of employment under the project, the employee will:
    - i. Abide by the terms of the statement, and;
    - ii. Notify the employer in writing of his or her conviction for a violation of a criminal drug statute occurring in the workplace no later than five (5) calendar days after such conviction;
  - e. Notifying the Department and the Federal Highway Administration in writing, within ten (10) calendar days after receiving notice under subparagraph (d)(ii) from an employee or otherwise receiving actual notice of such conviction. Employers of convicted employees must provide notice, including position title, to every project officer or other designee on whose project activity the convicted employee was working, unless the Federal Highway Administration has designated a central point for the

receipt of such notices. Notice shall include the identification numbers of each affected project.

- f. Taking one of the following actions, within thirty (30) calendar days of receiving notice under subparagraph (d)(ii), with respect to any employee who is so convicted.
- g. Taking appropriate personnel action against such an employee, up to and including termination, consistent with the requirements of the Rehabilitation Act of 1973; as amended, or;
- h. Requiring such employee to participate satisfactorily in a drug abuse assistance or rehabilitation program approved for such purposes by a Federal, State or local health, law enforcement, or other appropriate agency;
- i. Making a good faith effort to continue to maintain a drug free workplace through implementation of paragraphs (a), (b), (c), (d), (e) and (f).

**OKLAHOMA DEPARTMENT OF TRANSPORTATION  
ENGINEERING CONTRACT NO. EC-  
ATTACHMENT D5  
DISADVANTAGED BUSINESS ENTERPRISES POLICY STATEMENT**

1. It is the policy of the Department to ensure that Disadvantaged Business Enterprises (D.B.E.) as defined in 49 CFR Part 26 shall have the maximum opportunity to participate in the performance of contracts financed in whole or in part with federal funds under this Contract. Consequently the D.B.E. requirements of 49 CFR Part 26 applies to this Contract.
2. The Department or its Consultants which are recipients of Federal-aid funds agree to ensure that disadvantaged business enterprises as defined in 49 CFR Part 26 have the maximum opportunity to participate in the performance of contracts and sub-contracts financed in whole or in part with federal funds provided under this Contract. In this regard, the Department and its Consultants shall take all necessary and reasonable steps in accordance with 49 CFR Part 26 to ensure that disadvantaged business enterprises have the maximum opportunity to compete for and perform contracts. The Department and its Consultants shall not discriminate on the basis of race, color, national origin nor sex in the award and performance of Department assisted contracts.
3. Failure to carry out the requirements set forth above shall constitute a breach of Contract, and, after the notification of the Department, may result in termination of the Contract by the Department or other such remedy as the Department deems appropriate.



**US DOT CERTIFICATION FOR FEDERAL-AID CONTRACTS ACKNOWLEDGEMENT**

Before me, the undersigned, a Notary Public, in and for the State of \_\_\_\_\_, on this day personally appeared \_\_\_\_\_, known to me to be the person whose name is subscribed to the foregoing instrument as the maker thereof, whether as an individual, a member of said co-partnership, or authorized agent, or officer of said Corporation, and acknowledged to me that he or she executed the same as his or her free and voluntary act and deed for the purposes and reconsideration therein expressed, and in the capacity therein set forth.

Witness my hand and seal of office this \_\_\_\_ day of \_\_\_\_\_, 20\_\_\_\_.

\_\_\_\_\_  
Notary Public

Commission Number \_\_\_\_\_ My Commission Expires: \_\_\_\_\_







**OKLAHOMA DEPARTMENT OF TRANSPORTATION  
ENGINEERING CONTRACT NO. EC-  
ATTACHMENT G  
CERTIFICATE OF FINAL INDIRECT COSTS**

I, the undersigned representative of \_\_\_\_\_, (Consultant), certify that I have reviewed the proposal to establish final indirect cost rates for the fiscal period specified below and to the best of my knowledge and belief:

1. All costs included in this proposal to establish final indirect costs rates are allowable in accordance with the cost principles of the Federal Acquisition Regulations (FAR) of Title 48, Code of Federal Regulations (CFR), part 31.
2. This proposal does not include any costs which are expressly unallowable under the cost principles of the FAR of 48 CFR 31.

All known material transactions or events that have occurred affecting the firm's ownership, organization and indirect cost rates have been disclosed.

Fiscal Period Covered: \_\_\_\_\_  
(mm/dd/yyyy to mm/dd/yyyy)

\_\_\_\_\_  
Name of Consultant

\_\_\_\_\_  
Consultant Signature

\_\_\_\_\_  
Title

\_\_\_\_\_  
Date of Certification

**OKLAHOMA DEPARTMENT OF TRANSPORTATION  
ENGINEERING CONTRACT NO. EC- [REDACTED]  
ATTACHMENT H  
FINAL INVOICE CERTIFICATION**

I certify that all services documented by this invoice and for which payment is claimed were billed to the Department for hours actually expended by Consultant's staff members at the contractually specified rates for such staff members. I further certify the overhead rate as charged to this Contract has been audited by a certified public accounting firm, accepted by the Department, and has been properly applied to services provided under this Contract. I further certify that all Sub-Consultants, sub-contractors and others who provided labor, equipment or supplies have been fully paid.

I understand that if the project which is subject of this Contract is financed in whole or in part by federally furnished funds, that if I, the company that I represent, or any employee or agent thereof, knowingly make any false statement, representation, report, or claim as to the character, quality, quantity, or cost of material used or to be used, or quantity or quality of work performed or to be performed, or make any false statement or representation as a material fact in any statement, certificate, or report, I and the company that I represent may be subject to prosecution under the provisions of 18 U.S.C. Section 1001 and 1020.

EC- [REDACTED]

Task Order Number: \_\_\_\_\_

\_\_\_\_\_  
Signature

\_\_\_\_\_  
Printed Name

\_\_\_\_\_  
Position

\_\_\_\_\_  
Firm Name

Signed before me the undersigned notary this \_\_\_\_\_ day of \_\_\_\_\_, 20\_\_\_\_,

(SEAL)

\_\_\_\_\_  
Notary Public

My Commission Expires: \_\_\_\_\_

My Commission Number: \_\_\_\_\_



**OKLAHOMA DEPARTMENT OF TRANSPORTATION**  
**200 N.E. 21<sup>st</sup> Street**  
**Oklahoma City, OK 73105-3204**

---

Date

Consultant Name  
Address  
City

RE: EC-\_\_\_\_\_

A Pre-Negotiation Scope of Services meeting will be held regarding EC-\_\_\_\_\_ on \_\_\_\_\_ at \_\_\_\_\_ in the Oklahoma Department of Transportation \_\_\_\_\_ Conference Room (\_\_\_\_\_) to discuss any concerns or clarify the expectations of this project.

The negotiation meeting will be scheduled once the Scope of Services has been approved and a Fee Proposal and Overhead Rate Forms have been received.

Your interest in providing services in support of the Department's transportation projects and program is appreciated. If I can offer further assistance or if I can provide additional information, please feel free to contact me at (405) \_\_\_\_\_-\_\_\_\_\_.

Sincerely,

Contract Administrator

c: Consultant Selection Committee

**OKLAHOMA DEPARTMENT OF TRANSPORTATION  
ENGINEERING CONTRACT COST ESTIMATE**

E.C. NO. \_\_\_\_\_ SWO NO. \_\_\_\_\_  
 COUNTY \_\_\_\_\_ CITY \_\_\_\_\_ PROJECT NO. \_\_\_\_\_  
 HIGHWAY NO. \_\_\_\_\_ DESCRIPTION \_\_\_\_\_  
 NAME OF ORGANIZATION SUBMITTING ESTIMATE \_\_\_\_\_

Indicate appropriate type of services at top of column such as: Field Survey, Functional Plans, Bridge Design, Roadway Design, Etc.

	Bridge (# Sheets)		Roadway			
	MAN HOURS	COST	MAN HOURS	COST	MAN HOURS	COST
DIRECT SALARY COSTS						
Engineers						
Designers						
Draftsman						
Surveyors						
Supervision						
Others (Clerical)						
<b>Subtotal</b>						
PAYROLL ADDITIVE	PERCENT				PERCENT	
(Vacation, sick leave, retirement, FICA, etc.)						
DIRECT NON-PAYROLL COSTS						
Materials and supplies						
Reproduction						
Data Processing						
Travel expenses						
<b>Subtotal - All Direct Cost</b>						
INDIRECT COSTS						
(Administration, rent, utilities, telephone, etc.)						
<b>Subtotal - Direct and Indirect</b>						
PROFESSIONAL FEE (Profit)						
<b>TOTAL ESTIMATED FEE</b>						

TOTAL ESTIMATED FEE

Prepared by: \_\_\_\_\_  
 Signature

Date: \_\_\_\_\_

**OKLAHOMA DEPARTMENT OF TRANSPORTATION**  
**ROADWAY ENGINEERING CONTRACTS**  
**DEVELOPMENT OF SCOPE OF WORK AND FEE PROPOSAL**

**Establishment of the Scope of Work**

The Roadway Project Scope Form should be completed by the Consultant. A pre-negotiation meeting will be held, if necessary, to define the project scope. The completed Roadway Project Scope Form will be reviewed by ODOT Roadway Design Division and if approved the Consultant will write the scope in text format including any clarification necessary, then will prepare a fee proposal using the Roadway Engineering Contract Cost Proposal Spreadsheet.

**Establishment of Fee Proposal**

The Roadway Engineering Contract Cost Proposal Spreadsheet should be used to prepare fee proposals after the scope of work has been clearly defined and prior to negotiation. The Consultant and ODOT Roadway Design Division personnel will each complete a Fee Proposal Spreadsheet for each roadway project type anticipated. Examples of different project types are: Grade and Drain, Surfacing, Rehabilitation of Existing Lanes, etc. The Fee Proposal Spreadsheet will be used to establish a basis for comparison during negotiation.

Labor rates should be input for the maximum of six labor categories. Examples of labor categories are: Principle, Project Manager, Project Engineer, Design Engineer, Design Technician, CADD Technician, Clerical, etc.. Labor categories will be individualized for each consulting firm.

Input estimated hours for Sub-tasks, Tasks, or Activities, as appropriate. The spreadsheet automatically sums to the next level up; Sub-tasks to Tasks and Tasks to Activities. The Spreadsheet automatically computes a direct labor cost for each Activity using the estimated hours and labor rates

The payroll additive should be entered as a percentage of direct salary costs. Direct non-payroll costs should be entered in total dollars which will be added to the direct salary costs and payroll additives to determine all direct costs. For indirect cost, such as, administration, rent, utilities, etc., input the percentage of all direct costs. Profit should be entered in whole dollars. The spreadsheet will automatically sum the total estimated proposed fee for each project type.

OKLAHOMA DEPARTMENT OF TRANSPORTATION  
ROADWAY ENGINEERING CONTRACT COST PROPOSAL

E.C. NO. \_\_\_\_\_ SWO NO. \_\_\_\_\_ JOB PIECE NO. \_\_\_\_\_  
 COUNTY \_\_\_\_\_ CITY \_\_\_\_\_ PROJECT NO. \_\_\_\_\_  
 HIGHWAY NO. \_\_\_\_\_ ORGANIZATION SUBMITTING PROPOSAL \_\_\_\_\_  
 PROJECT DESCRIPTION \_\_\_\_\_

**DIRECT SALARY COSTS**

Labor Description	Labor Category				
	Principal	Project Manager	Project Engineer	Structural Engineer	Design Technician CAD Technician
Labor Rate					

Labor Description	HOURS					Sub-Task	Task	Activity	Cost
	0	0	0	0	0				
<b>ROADWAY PLAN DEVELOPMENT</b>									
3.2 Prepare Preliminary Roadway Plans									
3.2.2 Create Title Sheet And Generate Location Map									
3.2.5 Draft Typical Section									
3.2.6 Develop Plan & Profile Sheets									
3.2.6.2 Prepare Survey Files For Design									
3.2.6.3 Generate Horizontal Alignment									
3.2.6.5 Generate Existing Ground									
3.2.6.6 Generate Profile									
3.2.6.7 Generate P&P Sheets									
3.2.6.8 Draft P&P Sheets									
3.2.7 Design Drainage Structures									
3.2.7.1 Analyze Existing Drainage System									
3.2.7.2 Determine Size of Cross-Drain Structures									
3.2.7.3 Generate Drainage Map									
3.2.8 Develop Finished Grade Line									
3.2.8.1 Design Vertical Alignment									
3.2.8.2 Develop Templates									
3.2.8.3 Develop Preliminary Cross Sections									
3.2.8.5 Develop Preliminary End Areas And Volumes									
3.5.3 Design Superlevation									
3.7.1 Develop Preliminary Construction Sequence									

3.15 Establish Right-of-Way Requirements									
3.15.1 Finalize Horizontal and Vertical Alignments									
3.15.6 Develop R/W Submission Plans									
3.15.6.4 Design Driveways									
3.15.6.5 Design Side Drains									
3.15.6.6 Finalize Roadway Drainage Structure Design									
3.15.6.7 Design Special Drainage Structures									
3.18.2 Prepare Comparative Estimates for Pavement Design									

3.20 Prepare Roadway Final Cross Sections									
3.15.4 Develop Cross Sections									
3.15.4.1 Generate Cross Sections									
3.15.4.2 Drain Cross Sections									
3.15.4.4 Drafting On Cross Sections									
3.21.2 Perform Earthwork Calculations									
3.21.2.1 Calculate End Areas And Volumes									
3.21.2.2 Generate Mass Diagram									
3.21.2.3 Draft End Areas And Volumes On Cross Sections									

01/07/05 - Rev. 1

Footnote: If an item is not applicable, leave it blank.

OKLAHOMA DEPARTMENT OF TRANSPORTATION  
ROADWAY ENGINEERING CONTRACT COST PROPOSAL

DIRECT SALARY COSTS

Labor Description	Labor Category				
	Principal	Project Manager	Structural Engineer	Design Technician	CAD Technician
Labor Rate \$	\$ -	\$ -	\$ -	\$ -	\$ -

3.25 Prepare Traffic Final Plans	0	0	0	0	0	0
3.25.1 Develop Final Construction Traffic Control Plans						
3.25.2 Develop Final Signing & Striping Plans						
3.25.3 Develop Final Signal Plans						
3.25.4 Develop Final Lighting Plans						
3.31.1 Summarize Traffic Plans						

3.29 Prepare Roadway Final Plans	0	0	0	0	0	0
3.29.1 Develop Final Sequence Of Construction Sheets						
3.29.2 Calculate Quantities						
3.29.3 Generate Site Specific Erosion Control Plans						
3.29.4 Generate Storm Water Pollution Prevention Plan Sheet						
3.29.5 Generate Detail Sheets						
3.29.5.1 Design And Generate Joint Layout Sheets						
3.29.5.2 Design And Generate Drainage Structure Details						
3.29.5.3 Generate Miscellaneous Detail Sheets						
3.29.5.4 Generate Survey Data Sheets						
3.29.6 Generate Summary Sheets						
3.29.7 Assemble Pay Items And Notes						

I. Estimates / Reporting	0	0	0	0	0	0
3.11 Prepare Preliminary Plan Field Review Report & Cost Estimate						
3.28 Prepare Final Plan Field Review Report & Cost Estimate						
3.30 Prepare Final Cost Estimate Using Current ODOT Est. Software						
S-1 Prepare Special Provisions						
S-2 Drainage Studies and Reports						

II. Meetings	0	0	0	0	0	0
S-3 Confirmation of Scope & Fee Proposal						
S-4 Additional Meetings Outside Normal Project Requirements						
3.10 Preliminary Plan Field Review						
3.16 Right-of-Way & Utility Review						
3.27 Final Plan Field Review						
5.1 Pre-Bid						

<b>Sub-Total Direct Salary Costs</b>	<b>0</b>	<b>0</b>	<b>0</b>	<b>0</b>	<b>0</b>	<b>0</b>
--------------------------------------	----------	----------	----------	----------	----------	----------

01/07/05 - Rev. 1

Footnote: If an item is not applicable, leave it blank.

**OKLAHOMA DEPARTMENT OF TRANSPORTATION  
ROADWAY ENGINEERING CONTRACT COST PROPOSAL**

**DIRECT SALARY COSTS**

0

**PAYROLL ADDITIVE (Vacation, sick leave, retirement, FICA, etc.) (Input percentage of Direct Salary Costs)**

0

**DIRECT NON-PAYROLL COSTS**

- Materials & Supplies
- Reproduction
- Data Processing
- Travel Expenses
- Equipment Rental
- Other (specify)

**Subtotal**

0

**Subtotal - All Direct Costs**

0

**INDIRECT COSTS (Administration, rent, utilities, telephone, etc.) (Input percentage of All Direct Costs)**

0

**Subtotal - Direct & Indirect**

0

**PROFIT**

**TOTAL PROPOSED ROADWAY PLAN DEVELOPMENT FEE**

0

Computed Aggregate Rate per labor hour

#VALUE! per hour

Prepared by: \_\_\_\_\_ Date: \_\_\_\_\_



**OKLAHOMA DEPARTMENT OF TRANSPORTATION**

**BRIDGE ENGINEERING CONTRACTS**

**DEVELOPMENT OF SCOPE OF WORK AND FEE PROPOSAL**

**Establishment of Scope of Work**

The Scope of Work Development Sheet should be completed by the Consultant and then reviewed and approved by ODOT Bridge Division Personnel prior to the Consultant completing the Bridge Engineering Contract Fee Proposal Spread Sheet. A Scope of Work meeting will be held, if necessary, in order to complete the Scope of Work Development Sheet. The Scope of Services Work Sheet will aid in completing the Bridge Engineering Contract Fee Proposal Spread Sheet.

**Establishment of Fee Proposal**

The Bridge Engineering Contract Fee Proposal Spread Sheet should be used to prepare fee proposals after the scope of work has been clearly defined and prior to negotiation. The Consultant and ODOT Bridge Division Personnel will each complete a Fee Proposal Spreadsheet for each bridge or retaining wall, which will be used during negotiation to identify where major differences in computed work effort and fee occur.

Input labor rates for the labor categories that best describes your consulting firm. A maximum of six labor categories with related labor rate can be used in the spreadsheet. The categories are to be identified by the user. Examples of categories are: Supervisor, Project Engineer, Structural Designer, CADD Supervisor, CADD Technician, Clerical, etc.

Input estimated hours for Subtasks, Tasks, or Activities, as appropriate. The spreadsheet automatically sums to the next level up; Subtasks to Tasks and Tasks to Activities. The spreadsheet automatically uses the estimated hours and rates for the labor categories to establish a direct labor cost for each Activity.

The payroll additive should be entered as a percentage of direct salary costs. Direct non-payroll costs should be entered in total dollars which will be added to the direct salary costs and payroll additives to determine all direct costs. For indirect costs, such as, Administration, rent, utilities, telephone, etc., input the percentage of all direct costs. Profit should be entered in whole dollars. The spreadsheet will automatically sum the total estimated fee proposal for each bridge.

The maximum bridge construction services fee is to be input by ODOT Bridge Division Personnel to allow for funds to be set aside for construction related activities such as, issuing addenda, answering RFI's, computing beam haunches or conducting field observations during construction when asked to do so by ODOT Bridge Division Personnel. This fee or a portion thereof shall only be paid to the Consultant after the services are provided on an hourly basis.

**SCOPE OF WORK DEVELOPMENT SHEET  
For  
BRIDGE ENGINEERING**

<b>Generalized Project Scope</b>

**Number of Bridges in Project** \_\_\_\_\_

<b>Bridge Designation</b>	<b>Bridge Location Description</b>

Consultant Signature \_\_\_\_\_ Date \_\_\_\_\_ ODOT Bridge Signature \_\_\_\_\_ Date \_\_\_\_\_

**SCOPE OF WORK DEVELOPMENT SHEET**  
**For**  
**BRIDGE ENGINEERING**  
 (Sheet 1 of 2, per bridge or retaining walls / sound barrier)

**Bridge** \_\_\_\_\_ **Location** \_\_\_\_\_  
**Designation** \_\_\_\_\_ **Description** \_\_\_\_\_

Conceptual Studies? Describe.	
Functional Plans? Describe.	
Final Construction Plans?	
New Span Structure?	
Widen Existing Structure?	
Rehabilitate Existing Structure?	
New RCB Culvert?	
Extend Existing RCB Culvert?	
Retaining Walls? Describe.	

**SCOPE OF WORK DEVELOPMENT SHEET**  
**For**  
**BRIDGE ENGINEERING**  
 (Sheet 2 of 2, per bridge or retaining walls / sound barrier)

**Bridge Designation** \_\_\_\_\_ **Location Description** \_\_\_\_\_

<b>The Following Assumptions are For New Span Bridge</b>	
Twin Structure? First or Second Twin?	
Alternate Bid? First or Second Alternate?	
Describe Structure Material Type	
Phased Construction? Describe.	
Grade Separation or Stream Crossing?	
Skewed or Square?	
On Tangent or Curved Horizontal Alignment?	
Predominately Standard Drawings?	
Total Number of Spans	
Total Number of Superstructure Designs	
Total Number of Pier Designs	
Total Number of Abutment Designs	
Need Hydraulics? Describe.	
Need Channel Work? Describe.	
Need Spur Dikes? Describe.	
Need Geotechnical Information? Describe.	
Need Lighting / Signal Provisions on Bridge?	
Need Corp Permit? Describe.	
Need Special Provisions? Describe.	
Need RR Exhibit A? Describe.	

**SCOPE OF WORK DEVELOPEMNT SHEET**  
**For**  
**BRIDGE ENGINEERING**  
 (Sheet 2 of 2, per bridge or retaining walls / sound barrier)

**Bridge** \_\_\_\_\_ **Location** \_\_\_\_\_  
**Designation** \_\_\_\_\_ **Description** \_\_\_\_\_

<b>The Following Assumptions are For Widening Existing Span Bridge</b>	
Twin Structure? First or Second Twin?	
Alternate Bid? First or Second Alternate?	
Describe Structure Material Type	
Phased Construction? Describe.	
Grade Separation or Stream Crossing?	
Skewed or Square?	
On Tangent or Curved Horizontal Alignment?	
Replace Deck or Rehabilitate Deck?	
If Rehab Deck, Is there an Overlay? Describe.	
Rehabilitate Beams? Describe.	
Rehabilitate Piers? Describe.	
Rehabilitate Abutments? Describe.	
Total Number of Spans	
Total Number of Superstructure Designs	
Total Number of Pier Designs	
Total Number of Abutment Designs	
Need Hydraulics? Describe.	
Need Channel Work? Describe.	
Need Spur Dikes? Describe.	
Need Geotechnical Information? Describe.	
Need Lighting / Signal Provisions on Bridge?	
Need Corp Permit? Describe.	
Need Special Provisions? Describe.	
Need RR Exhibit A? Describe.	

**SCOPE OF WORK DEVELOPMENT SHEET**  
**For**  
**BRIDGE ENGINEERING**  
 (Sheet 2 of 2, per bridge or retaining walls / sound barrier)

**Bridge** \_\_\_\_\_ **Location** \_\_\_\_\_  
**Designation** \_\_\_\_\_ **Description** \_\_\_\_\_

<b>The Following Assumptions are For Rehabilitating Existing Span Bridge W/O Widening</b>	
Twin Structure? First or Second Twin?	
Describe Structure Material Type	
Phased Construction? Describe.	
Grade Separation or Stream Crossing?	
Skewed or Square?	
On Tangent or Curved Horizontal Alignment?	
Is there an Overlay? Describe.	
Rehabilitate Beams? Describe.	
Rehabilitate Piers? Describe.	
Rehabilitate Abutments? Describe.	
Total Number of Spans	
Total Number of Superstructure Designs	
Total Number of Pier Designs	
Total Number of Abutment Designs	
Need Hydraulics? Describe.	
Need Channel Work? Describe.	
Need Spur Dikes? Describe.	
Need Geotechnical Information? Describe.	
Need Corp Permit? Describe.	
Need Special Provisions? Describe.	
Need RR Exhibit A? Describe.	

**SCOPE OF WORK DEVELOPMENT SHEET**  
**For**  
**BRIDGE ENGINEERING**  
 (Sheet 2 of 2, per bridge or retaining walls / sound barrier)

**Bridge** \_\_\_\_\_ **Location** \_\_\_\_\_  
**Designation** \_\_\_\_\_ **Description** \_\_\_\_\_

<b>The Following Assumptions are For RCB Culverts</b>	
New RCB or Extend Existing RCB?	
If Extension, One Sided or Two Sided?	
Phased Construction? Describe.	
Grade Separation or Stream Crossing?	
Skewed or Square?	
Broken Back? Describe.	
Drop Structure? Describe.	
Energy Dissipator? Describe.	
Predominately Standard Drawings?	
Number of Barrel Designs.	
Number of Wing / Apron Designs.	
Need Hydraulics? Describe.	
Need Channel Work? Describe.	
Need Spur Dikes? Describe.	
Need Geotechnical Information? Describe.	
Need Corp Permit? Describe.	
Need Special Provisions? Describe.	
Need RR Exhibit A? Describe.	

**SCOPE OF WORK DEVELOPMENT SHEET**  
**For**  
**BRIDGE ENGINEERING**  
 (Sheet 2 of 2, per bridge or retaining walls / sound barrier)

**Bridge** \_\_\_\_\_ **Location** \_\_\_\_\_  
**Designation** \_\_\_\_\_ **Description** \_\_\_\_\_

<b>The Following Assumptions are For Retaining Walls / Sound Barriers</b>	
Number of Individual Walls?	
Wall Location Map Required?	
Number of Individual Wall Panel Designs?	
Esthetic Treatment Required? Describe.	
Need Geotechnical Information? Describe.	
Need Corp Permit? Describe.	
Need Special Provisions? Describe.	
Need RR Exhibit A? Describe.	



OKLAHOMA DEPARTMENT OF TRANSPORTATION  
BRIDGE ENGINEERING CONTRACT FEE PROPOSAL  
Sheet 1 of 4

E.C. NO. \_\_\_\_\_ SWO NO. \_\_\_\_\_ JOB PIECE NO. \_\_\_\_\_  
 COUNTY \_\_\_\_\_ CITY \_\_\_\_\_ PROJECT NO. \_\_\_\_\_  
 HIGHWAY NO. \_\_\_\_\_ PROJECT DESCRIPTION \_\_\_\_\_  
 BRIDGE DESIGNATION \_\_\_\_\_ BRIDGE DESCRIPTION \_\_\_\_\_

NAME OF ORGANIZATION SUBMITTING PROPOSAL \_\_\_\_\_

LABOR CATEGORY	HOURS						Sub-Task	Task	Activity	Cost	
	1	2	3	4	5	6					
<b>DIRECT SALARY COSTS</b>											
<b>BRIDGE PLAN DEVELOPMENT</b>											
<b>3.3 Perform Bridge Hydraulics</b>											
3.3.1	Perform Hydraulic Analysis/Design										
3.3.2	Attend Hydraulic Conferences										
3.3.3	Produce Hydraulic Report										
<b>3.4 Generate Bridge Finished Grade Requirements</b>											
<b>3.8 Prepare Preliminary Bridge Plans</b>											
3.8.1	Compute Preliminary Geometrics										
3.8.2	Perform Preliminary Structural Design										
3.8.3	Perform Comparative Cost Estimates										
3.8.4	Draft Preliminary Bridge Plans										
3.8.4.1	Draft Preliminary General Plan & Elevation										
3.8.4.2	Draft Preliminary Sequence of Construction Sheets (if Necessary)										
3.8.4.3	Draft Preliminary Details (if Necessary)										
3.8.5	Check & Review Preliminary Bridge Plans										
3.8.6	Prepare Cost Estimate										
<b>3.10 Attend Preliminary Plan Field Review</b>											
<b>3.11 Perform Post-Preliminary Field Review Process</b>											
3.11.3	Prepare Preliminary Plan Field Review Report										
3.11.7	Make Changes From Preliminary Plan Field Review										
3.11.7.1	Make Changes to Bridge Plans										
3.11.7.3	Revise Cost Estimate Based Upon Square Foot Costs										
<b>3.12 Generate Bridge Sounding Requirements</b>											
3.12.1	Layout Boring Locations On GP&E										
<b>3.14 Prepare Corps Permit Application</b>											
<b>3.16 Attend Right-of-Way &amp; Utility Meeting</b>											
<b>3.17 Perform Railroad Process</b>											
3.17.2	Bridge Drafts and Supplies Exhibit A										

Footnote: If an item is not applicable, leave the box blank.

OKLAHOMA DEPARTMENT OF TRANSPORTATION  
 BRIDGE ENGINEERING CONTRACT FEE PROPOSAL  
 Sheet 2 of 4

Labor Description Labor Rate	LABOR CATEGORY						Sub-Task	Task	Activity	Cost
	1	2	3	4	5	6				
	HOURS									
<b>Bridge</b>										
<b>3.22 Prepare Bridge Structural Design</b>										
3.22.1 Perform Structural Design of Components										
3.22.1.1 Design Superstructure										
3.22.1.2 Design Piers										
3.22.1.3 Design Abutment										
3.22.1.4 Design R.C. Box										
3.22.1.5 Design Retaining Walls/Sound Walls										
3.22.1.6 Design Miscellaneous Components										
<b>3.22.2 Perform Structural Design Check of Components</b>										
3.22.2.1 Check Superstructure										
3.22.2.2 Check Piers										
3.22.2.3 Check Abutment										
3.22.2.4 Check R. C. Box										
3.22.2.5 Check Retaining Walls/Sound Walls										
3.22.2.6 Check Miscellaneous Components										
<b>3.23 Prepare Bridge Foundation Design</b>										
3.23.1 Review Bridge Geotechnical Report										
3.23.2 Develop & Plot Foundation Report Sheets										
3.23.3 Develop Foundation Design Parameters										
3.23.4 Attend Foundation Conference										
<b>3.24 Prepare Bridge Final Plan Field Review Plans</b>										
3.24.1 Compute Final Bridge Geometry										
3.24.1.1 Compute Final Overall Geometry										
3.24.1.2 Compute Final Component Geometry										
3.24.2 Draft Proposed Bridge Plans										
3.24.2.1 Modify Proposed General Plan & Elevation										
3.24.2.2 Modify Proposed Sequence of Construction Sheets										
3.24.2.3 Draft Proposed Detail Sheets as Req. for Constructability Review										
3.24.3 Check & Review Proposed Bridge Plans										
3.24.4 Prepare Cost Estimate Based upon Preliminary Quantities										
<b>3.27 Attend Final Plan Field Review</b>										
<b>3.28 Perform Post-Final Field Review Process</b>										
3.28.1 Prepare Final Plan Field Review Report										
3.28.4 Make Changes From Final Plan Field Review										
3.28.4.1 Make Changes to Bridge Plans										
3.28.4.5 Revise Cost Estimate Based Upon Preliminary Quantities										

Footnote: If an item is not applicable, leave the box blank.

OKLAHOMA DEPARTMENT OF TRANSPORTATION  
BRIDGE ENGINEERING CONTRACT FEE PROPOSAL  
Sheet 3 of 4

Labor Description Labor Rate	LABOR CATEGORY						Sub-Task	Task	Activity	Cost
	1	2	3	4	5	6				
HOURS										
<b>3.30</b>	<b>Prepare Bridge Final Plans</b>									
<b>3.30.1</b>	<b>Prepare Final Bridge Detail Sheets</b>									
3.30.1.1	Finalize General Plan & Elevation Sheet(s)									
3.30.1.2	Finalize Construction Phasing Sheet(s)									
3.30.1.3	Finalize Foundation Report Sheet(s)									
3.30.1.4	Prepare Staking Detail Sheet(s)									
3.30.1.5	Prepare Abutment Detail Sheet(s)									
3.30.1.6	Prepare Wingwall Detail Sheet(s)									
3.30.1.7	Prepare Substructure Excavation Detail Sheet(s)									
3.30.1.8	Prepare Pier Detail Sheet(s)									
3.30.1.9	Prepare Superstructure Detail Sheet(s)									
3.30.1.10	Prepare Beam Detail Sheet(s)									
3.30.1.11	Prepare Bearing Assembly Detail Sheet(s)									
3.30.1.12	Prepare Approach Slab Detail Sheet(s)									
3.30.1.13	Prepare Slope Wall Detail Sheet(s)									
3.30.1.14	Prepare Riprap Detail Sheet(s)									
3.30.1.15	Prepare Bridge Rehabilitation Detail Sheet(s)									
3.30.1.16	Prepare RCB Barrel Detail Sheet(s)									
3.30.1.17	Prepare RCB Wing/Apron Detail Sheet(s)									
3.30.1.18	Prepare Channel Modification Sheet(s)									
3.30.1.19	Prepare Retaining Walls/Sound Walls Layout Sheet(s)									
3.30.1.20	Prepare Retaining Walls/Sound Walls Detail Sheet(s)									
3.30.1.21	Prepare Miscellaneous Detail Sheet(s)									
<b>3.30.2</b>	<b>Compute Quantities</b>									
<b>3.30.3</b>	<b>Prepare Bridge General Notes Sheet(s)</b>									
<b>3.30.4</b>	<b>Prepare Bridge Summary of Quantities Sheet(s)</b>									
<b>3.30.5</b>	<b>Prepare Bridge Special Provision(s)</b>									
<b>3.30.6</b>	<b>Check &amp; Review Final Bridge Plans</b>									
<b>3.30.7</b>	<b>Prepare Final Bridge Construction Estimate</b>									
<b>5.1</b>	<b>Perform Plan Revisions</b>									
5.1.1	Revise Plans per Review Comments									
5.1.2	Attend Pre-Bid Conference									
<b>Sub-Total Direct Salary Costs</b>										

Footnote: If an item is not applicable, leave the box blank.

OKLAHOMA DEPARTMENT OF TRANSPORTATION  
 BRIDGE ENGINEERING CONTRACT FEE PROPOSAL  
 Sheet 4 of 4

<b>DIRECT SALARY COSTS</b>		hours	
<b>PAYROLL ADDITIVE</b> (Vacation, sick leave, retirement, FICA, etc.) Input percentage of Direct Salary Costs			
<b>DIRECT NON-PAYROLL COSTS</b>			
Materials & Supplies			
Reproduction			
Data Processing			
Travel Expenses			
Equipment Rental			
Outside Engr. Consultants			
Other (specify)			
<b>Subtotal</b>			
<b>Subtotal - All Direct Costs</b>			
<b>INDIRECT COSTS</b> (Administration, rent, utilities, telephone, etc.) Input percentage of All Direct Costs)			
<b>Subtotal - Direct &amp; Indirect</b>			
<b>PROFIT</b>			
<b>TOTAL PROPOSED BRIDGE PLAN DEVELOPMENT FEE</b>			
Computed Aggregate Rate per Labor Hour			per hour
<b>MAXIMUM BRIDGE CONSTRUCTION SERVICES FEE</b>			
<b>TOTAL PROPOSED BRIDGE FEE</b>			

Prepared by: \_\_\_\_\_ Date: \_\_\_\_\_

Footnote: If an item is not applicable, leave the box blank.

OKLAHOMA DEPARTMENT OF TRANSPORTATION  
SURVEYING CONTRACT COST PROPOSAL

E.C. NO. \_\_\_\_\_ SWO \_\_\_\_\_ JOB PIECE NO. \_\_\_\_\_  
 COUNTY \_\_\_\_\_ CITY \_\_\_\_\_ PROJECT NO. \_\_\_\_\_  
 HIGHWAY \_\_\_\_\_ ORGANIZATION SUBMITTING PROPOSAL \_\_\_\_\_  
 PROJECT DESCRIPTION \_\_\_\_\_

DIRECT SALARY COSTS

Labor Description	Labor Category					Sub-Task	Task	Activity	Cost
	Prof. Land Surveyor	Survey Party Chief	Survey Crew Member	CAD Technician	Admin. Clerical				
Labor Rate	HOURS								
<b>3.1 - SURVEY</b>	0	0	0	0	0	0	0	0	\$ -
<b>3.1.1.0 Preliminary Research</b>									
3.1.1.1 Obtain Property Ownerships / Deeds / Etc.									
3.1.1.2 Obtain Existing R/W Deeds & Easements									
3.1.1.3 Obtain Existing R/W & Construction Plans									
3.1.1.4 Land Survey Research									
3.1.1.5 Contact Property Owners For Right-Of-Entry									
<b>3.1.2.0 Primary Horizontal Control Network</b>	0	0	0	0	0	0	0	0	\$ -
3.1.2.1 Recover NGS Control									
3.1.2.2 Establish Primary Control Points									
3.1.2.3 GPS Sessions / Field Traverse									
3.1.2.4 Data Reduction / Office Adjustment / Etc.									
<b>3.1.3.0 Hub and Adjust Centerline of Survey</b>	0	0	0	0	0	0	0	0	\$ -
3.1.3.1 Establish Secondary Control Points									
3.1.3.2 Recover Alignment Control Shown On Previous Surveys & Plans									
3.1.3.3 Obtain Preliminary Data									
3.1.3.4 Data Reduction & Determination of Final Centerline Alignment									
3.1.3.5 Set, Measure & Reference Centerline Control Points									
<b>3.1.4.0 Vertical Control</b>	0	0	0	0	0	0	0	0	\$ -
3.1.4.1 Recover NGS / USGS Control									
3.1.4.2 Set Project Bench Marks									
3.1.4.3 Complete Level Loop(s) / Data Reduction / Adjustment									
3.1.4.4 Create Bench Marks & Check Levels List									

OKLAHOMA DEPARTMENT OF TRANSPORTATION  
SURVEYING CONTRACT COST PROPOSAL

DIRECT SALARY COSTS

Labor Description	Labor Category					
	Prof. Land Surveyor	Survey Party Chief	Survey Party Member	Survey Crew Member	CAD Technician	Admin. Clerical
Labor Rate \$	\$ -	\$ -	\$ -	\$ -	\$ -	\$ -

Labor Description	HOURS						Sub-Task	Task	Activity	Cost
	Prof. Land Surveyor	Survey Party Chief	Survey Party Member	Survey Crew Member	CAD Technician	Admin. Clerical				
<b>3.1.5.0 Surface Features / Digital Terrain Model (DTM)</b>	0	0	0	0	0	0	0	0	0	\$ -
3.1.5.1 Conventional Survey Method										
3.1.5.2 Aerial Photogrammetric Method										
3.1.5.2.1 Set Aerial Targets & Obtain 3-D Positioning										
3.1.5.2.2 Obtain Aerial Photography										
3.1.5.2.3 Check & Scan Film										
3.1.5.2.4 Perform Aero-Triangulation										
3.1.5.2.5 Perform Stereo Compilation										
3.1.5.2.6 Obtain Pavement Profile(s)										
<b>3.1.5.3 LIDAR Method</b>										
3.1.5.3.1 Set Targets & Obtain 3-D Positioning										
3.1.5.3.2 Perform 3-D Laser Scanning										
3.1.5.3.3 Process And Edit Data										
3.1.5.3.4 Obtain Pavement Profile(s)										
<b>3.1.6.0 Topography / Planimetrics</b>	0	0	0	0	0	0	0	0	0	\$ -
3.1.6.1 Conventional Survey Method										
3.1.6.1.1 Field Data Collection										
3.1.6.1.2 Data Reduction & Processing										
<b>3.1.6.2 Aerial Photogrammetric Method</b>										
3.1.6.2.1 Field Identification of Topographic/Planimetric Features										
3.1.6.2.2 Data Reduction & Processing										
<b>3.1.6.3 LIDAR Method</b>										
3.1.6.3.1 Field Identification of Topographic/Planimetric Features										
3.1.6.3.2 Data Reduction & Processing										
<b>3.1.7.0 Land Ties</b>	0	0	0	0	0	0	0	0	0	\$ -
3.1.7.1 Field Reconnaissance For Existing Monuments & Evidence										
3.1.7.2 Data Collection & Processing										
3.1.7.3 Computation of Land Corner Position(s)										
3.1.7.4 Set & Reference Land Corner(s)										
3.1.7.5 Complete & File Public Land Survey Corner Records										
<b>3.1.8.0 Locate Underground Utilities (Including Underground Storage Tanks)</b>	0	0	0	0	0	0	0	0	0	\$ -
3.1.8.1 Utility Company Notification / Coordination										
3.1.8.2 Field Data Collection										
3.1.8.3 Data Reduction / Processing										
<b>3.1.9.0 Hydraulics / Drainage Information</b>	0	0	0	0	0	0	0	0	0	\$ -
3.1.9.1 Hydrographic Data Collection On Major Rivers / Lakes										
3.1.9.2 Obtain Flowline Profile(s)										
3.1.9.3 Ravine Sections Through Flood Plain										
3.1.9.4 Gather & Document High Water Information										
3.1.9.5 Field Check Drainage Divides										
3.1.9.6 Produce Raster Drainage Map										

Mar-10

Footnote: If an item is not applicable, leave it blank.

OKLAHOMA DEPARTMENT OF TRANSPORTATION  
SURVEYING CONTRACT COST PROPOSAL

DIRECT SALARY COSTS

Labor Description	Labor Category					Clerical
	Prof. Land Surveyor	Survey Party Chief	Survey Crew Member	CAD Technician	Admin.	
	\$ -	\$ -	\$ -	\$ -	\$ -	\$ -
	HOURS					
<b>3.1.10.0 Office Work</b>	0	0	0	0	0	0
3.1.10.1 Complete CAD File(s) / Survey Data Sheets						0
3.1.10.2 Complete Historical & Written Report of Survey, ODOT Forms, Etc.						0
3.1.10.3 Preparation of Fee Proposal & Misc. Office Work (attach detail)						0
<b>3.1.11.0 Other</b>	0	0	0	0	0	0
3.1.11.1 Contract Administration & Invoicing						0
3.1.11.2						0
<b>3.1.12 Meetings</b>	0	0	0	0	0	0
3.1.12.1 Kick-Off / Stakeholder's Meeting						0
3.1.12.2 Confirmation of Scope & Fee Proposal						0
3.1.12.3 Pre-Negotiation Meeting						0
3.1.12.4 Contract Negotiation Meeting						0
3.1.12.5						0
3.1.12.6						0
<b>Sub-Total Direct Salary Costs</b>	0	0	0	0	0	0

DIRECT SALARY COSTS

\$ -
------

PAYROLL ADDITIVE (Vacation, sick Leave, retirement, FICA, etc.) (Input percentage of Direct Salary Costs)

0
---

DIRECT NON-PAYROLL COSTS

Materials & Supplies	
Reproduction	
Data Processing	
Travel Expenses	
Equipment Rental	
Filing Fees	
Other (specify)	
<b>Subtotal</b>	\$ -

Subtotal - All Direct Costs

\$ -
------

INDIRECT COSTS (Administration, rent, utilities, telephone, etc.) (Input percentage of All Direct Costs)

0
---

Subtotal - Direct & Indirect

\$ -
------

PROFIT

0
---

TOTAL PROPOSED SURVEY FEE

\$ -
------

Computed Aggregate Rate per labor hour  per hour

Prepared by: \_\_\_\_\_ Date: \_\_\_\_\_



**OKLAHOMA DEPARTMENT OF TRANSPORTATION**  
**200 N.E. 21<sup>st</sup> Street**  
**Oklahoma City, OK 73105-3204**

---

Date

Consultant Name  
Address  
City

The Selection Committee has completed their evaluations of EC-\_\_\_\_\_, and has selected your firm to perform the services for the referenced contract.

The Department targets this contract for approval at the \_\_\_\_\_ regular meeting of the Oklahoma Transportation Commission. We request you prepare a draft scope of work that demonstrates your knowledge of the project requirements. Please submit all information by \_\_\_\_\_ to the Project Management Division, Room 1C-4A, Attn.: \_\_\_\_\_, Oklahoma Department of Transportation, 200 N.E. 21<sup>st</sup> Street, Oklahoma City, Oklahoma 73105-3204. A negotiation meeting will be scheduled at a later date.

We appreciate your interest and commitment in support of Oklahoma's transportation program. Should you have any questions or comments, please contact \_\_\_\_\_ of the Project Management Division, (405) \_\_\_\_\_ - \_\_\_\_\_, for further assistance.

Sincerely,

Contract Administrator

c: Consultant Selection Committee



**FOR PRESENTATION AT THE COMMISSION MEETING ON DATE**

**AGENDA ITEM NO:**

**SUBJECT:           Engineering Contracts**

**County - Commission District Number (E.C. Number)**

The Department has selected \_\_\_\_\_ to perform preliminary engineering and to prepare final construction plans for \_\_\_\_\_. The engineering services will include survey, geotechnical studies and preliminary and final design, and will culminate in the submittal of the Plans, Specifications and Estimate (PS&E).

E.C. Number - Consultant

Total - Not to Exceed Amount                   \$ \_\_\_\_\_

The project is included in the 8-year construction work plan with a scheduled let date in FFY \_\_\_\_\_. The total estimate for construction contract for this project is \$ \_\_\_\_\_.

This contract will be funded with 80% Federal and 20% Soft Match Credit.

**APPROVAL IS RECOMMENDED**



**OKLAHOMA DEPARTMENT OF TRANSPORTATION**  
**200 N.E. 21<sup>st</sup> Street**  
**Oklahoma City, OK 73105-3204**

---

**DATE:**

**TO: Federal Highway Administration**

**FROM: Contract Administrator**

**SUBJECT: Full-oversight Federal-aid Contract Execution**

The Consultant and the Department have executed EC-\_\_\_\_\_. The Department respectfully request FHWA approval of this full-oversight federal-aid contract. The following information is attached:

- The scope of services
- The solicitation
- Evaluation ranking
- Interview ranking
- Department's estimate for negotiation
- Contract and supplements
- All task orders

# OKLAHOMA DEPARTMENT OF TRANSPORTATION

## REQUEST FOR ENCUMBRANCE

**DATE:**

**TO:**               **COMPTROLLER / PURCHASING**

**FROM:**           **PROJECT MANAGEMENT DIVISION**

**SUBJECT:**

<b>ISSUE NEW PO    YES ( X )    NO ( )</b>	
REQUISITION NUMBER:	
JOB PIECE:	
PROJECT NUMBER:	
VENDOR NAME:	
ODOT VENDOR NUMBER:	
CONTRACT TOTAL:	
FUND:	
ODOT EXPENSE ACCOUNT:	
ADDITIONAL COMMENTS:	
<b>INFORMATION FOR PEOPLE SOFT ENTRY:</b>	
OSF VENDOR NUMBER:	LOCATION:
FUND TYPE:	
CLASS FUND:	
DEPARTMENT:	
OPERATING UNIT:	
ITEM ID:	
ACCOUNT:	
BILL TO:	
PURCHASE ORDER NUMBER:	
PURCHASING APPROVAL                      Date	COMPTROLLER APPROVAL                      Date
If you have any questions call:	



**OKLAHOMA DEPARTMENT OF TRANSPORTATION**  
**200 N.E. 21<sup>st</sup> Street**  
**Oklahoma City, OK 73105-3204**

---

Date

Consultant Name  
Address  
City

RE: EC-\_\_\_\_\_ – Notice to Proceed

Dear \_\_\_\_\_:

\_\_\_\_\_ is authorized to begin work on the above-mentioned contract effective Date.  
Specifics are outlined in the contract.

If you have any questions, please contact me at (405) \_\_\_\_-\_\_\_\_.

Sincerely,

Contract Administrator

c: Associated Divisions  
Project Management Division

APPENDIX 6.02

OKLAHOMA DEPARTMENT OF TRANSPORTATION  CONSULTANT PERFORMANCE EVALUATION		EC No.			
		JP No.			
Consultant:		Rating Dates			
Project Description:		Contract Phase		Preconstruction Phase	
		Construction Phase		Other (Specify)	
		Rating Key (see instructions) (E) Exceeds Standards (M) Meets Standards (I) Needs Improvement (NA) Not Applicable			
EVALUATION FACTORS	Contract Phase	Preconstruction Phase			Construction Phase
		NEPA	Bridge	Roadway	
<b>A. Knowledge of Department Processes</b>					
<b>B. Cooperation with the Department, Public, Other Agencies</b>					
<b>C. Adequacy of Personnel, Supervision, and Management</b>					
<b>D. Timely Submission of Work</b>					
<b>E. Accuracy of Billing Records</b>					
<b>F. Overall Quality and Accuracy of Work</b>					
<b>G. Control of Work</b> (Construction Management Contracts Only)					
<b>H. Contractor Coordination</b> (Construction Management Contracts Only)					
<b>I. Ability to Maintain Construction Schedule</b> (Construction Management Contracts Only)					
<b>Rater: Project Engineer / Manager</b>					
<b>Reviewer: Division Engineer / Manager</b>					
<b>Assistant Chief Engineer</b>					
<b>Remarks:</b>					

<b>OKLAHOMA DEPARTMENT OF TRANSPORTATION</b>	
<b>CONSULTANT PERFORMANCE EVALUATION</b>	
<b>Evaluation Factors</b>	
<b>Knowledge of Department Processes</b>	
<b>Exceeds Standards</b>	Consultant displays thorough understanding of Department processes, policies and procedures. Project reports, plans, and calculations are prepared consistent with Department standards, in acceptable format, and with minimal errors. Timely submission of deliverables indicates a thorough understanding of Department scheduling processes and priorities.
<b>Meets Standards</b>	Consultant displays general understanding of Department processes, policies and procedures. Project deliverables are prepared consistent with Department standards and contain few errors. Identified errors do not impact Department's project delivery date or project budget.
<b>Needs Improvement</b>	Consultant is unfamiliar with, or fails to follow, Department processes, policies and procedures. Requires repeated instruction in preparation of normal documentation, correspondence, or reports. Deliverables contain numerous errors which negatively impacting either project delivery date or project budget.
<b>Cooperation with the Department, Public, Other Agencies</b>	
<b>Exceeds Standards</b>	Consultant displays willingness to embrace Team concept in the development of the project. Readily accessible to Department Staff and responsive to Department requests. Responds in a timely manner and with professional demeanor to all public requests for information. Develops and maintains positive working relationships with Federal / State Agencies involved in the project. All written and verbal communication delivered in a professional manner.
<b>Meets Standards</b>	Consultant works well with Department personnel in prosecution of the project. Generally responsive to Department requests for information. Occasional Department involvement required in coordination and delivery of information to the public and other agencies. Written and verbal communication was generally adequate.
<b>Needs Improvement</b>	Consultant was generally unresponsive to Department requests for information. Interaction with the public and other agencies was generally ineffective or unprofessional. Written and verbal communication was generally late or did not provide the requested information.
<b>Adequacy of Personnel, Supervision, and Management</b>	
<b>Exceeds Standards</b>	Consultant staff was competent and knowledgeable of all applicable guidelines, standards, and regulations required to complete the tasks. Level of staffing was adequate for the assigned work and product delivery dates were met and occasionally exceeded. Management involvement was timely and decisions were made at the appropriate level.
<b>Meets Standards</b>	Consultant staff displayed a general understanding of the expertise required to perform the assigned tasks. Staffing level was generally adequate to meet milestone deadlines. Management involvement was generally timely and few delays were experienced.
<b>Needs Improvement</b>	Consultant staff is generally unfamiliar with applicable guidelines, standards, and regulations required for task completion. Staffing level was inadequate for the level of work to be performed, resulting in delays in achieving milestone dates and adversely impacting the project delivery schedule. Management involvement was insufficient to meet the requirements of project delivery.

APPENDIX 6.02

<b>Timely Submission of Work</b>	
<b>Exceeds Standards</b>	Consultant submitted work in a timely manner, contributing to a smooth work flow and meeting or exceeding milestone dates. Displayed awareness of issues impacting project delivery schedule, and was an active participant in the decision making process. Department approvals were obtained in a timely manner. Submitted work was consistently free of errors and met or exceeded Department standards for quality.
<b>Meets Standards</b>	Consultant work was submitted in adherence with the project schedule. Department approvals were obtained prior to submission deadlines. Submitted work contained minimal errors and did not adversely impact project delivery date or project budget.
<b>Needs Improvement</b>	Consultant work was incomplete and consistently did not meet milestone dates. Work contained a sufficient amount of errors to impact project delivery date or project budget. Consultant ignored or was unaware of Department approval requirements. Submitted work required continuous review by Department staff.
<b>Accuracy of Billing Records</b>	
<b>Exceeds Standards</b>	Consultant provided Department with mathematically correct and itemized breakdown of billing charges in accordance with approved accounting requirements. Salaries, fixed fees, and other rates were consistent with the contract cost proposal. Requests for clarification or supporting documentation were addressed completely and in a timely manner.
<b>Meets Standards</b>	Consultant billing requests were generally correct and with minimal errors. Salaries, fixed fees, and other rates were consistent with the contract cost proposal. Requests for clarification and supporting documentation were addressed in a timely manner.
<b>Needs Improvement</b>	Consultant billing requests were consistently vague or inaccurate. Numerous errors required continuous research by Department staff and resulted in increased claim processing time. Billed fees were inconsistent with the contract cost proposal. Supporting documentation was absent or insufficient to support the billing claim.
<b>Overall Quality and Accuracy of Work</b>	
<b>Exceeds Standards</b>	Consultant work was technically accurate, complete, and submitted in a manner consistent with Department requirements. Work displayed a complete understanding of the project scope and was consistent with the contract document and Department standards for that type work. Work was submitted with adherence to the contract milestone dates and displayed professional competence with regard to content. Few errors were discovered and those errors did not impact either the project delivery date or project budget.
<b>Meets Standards</b>	Consultant work was generally complete and accurate. Work was consistent with the project scope and the contract document. Errors were minimal and were addressed in a timely manner by the Consultant. Errors did not affect the project delivery date or project budget.
<b>Needs Improvement</b>	Consultant work was submitted incomplete and reflected a lack of technical competency in the disciplines required to perform the work. Quantity or significance of errors necessitated Department involvement and correction. The work was inconsistent with the project scope or the contract requirements. The quantity or significance of the errors adversely impacted the project delivery date or the project budget.

APPENDIX 6.02

<b>Control of Work</b>	
<b>Exceeds Standards</b>	Consultant effectively and accurately administered the construction contract. Consultant representatives were very knowledgeable of Department processes, policies and procedures. Time and diaries were accurate and completed daily. Materials documentation was accurate and timely. Progressive claims were accurate and submitted in a timely manner. Department staff was kept current on project schedule and issues related to construction of the project. Field issues were handled at the appropriate level. The consultant was pro-active in identifying potential problems, and provided solutions to construction issues before the issues became critical.
<b>Meets Standards</b>	Consultant effectively administered the construction contract. Consultant representatives were generally knowledgeable of Department processes, policies and procedures. Time and diaries were completed with few errors. Materials documentation was accurate. Progressive claims were generally accurate and submitted in a timely manner. Department staff was generally kept informed of issues related to construction of the project. Field issues were handled at the appropriate level, with occasional guidance from the Field Division. Potential problems were generally identified early enough to be addressed by the Field Division
<b>Needs Improvement</b>	Consultant experienced frequent problems in administering the construction contract. Consultant representatives were occasionally unaware of Department processes, policies and procedures. Construction documentation was incomplete or inaccurate. Progressive claims were frequently inaccurate or submitted late. Department staff was frequently not informed of pending issues, and the Consultant was not proactive in identifying potential problems. Field Division personnel frequently were called to the project site to assist the Consultant in dealing with construction issues.
<b>Contractor Coordination</b>	
<b>Exceeds Standards</b>	Consultant displayed ability to effectively coordinate with the construction contractor. Correspondence generated by the consultant was accurate, timely, and displayed a thorough understanding of Department policies, processes, and procedures. Construction meetings were timely and proactively addressed potential construction issues. Construction issues were handled at the appropriate level and Field Division input was secured at the appropriate time in with the appropriate documentation.
<b>Meets Standards</b>	Consultant generally displayed ability to coordinate with the construction contractor. Correspondence generated by the consultant was generally accurate and timely. The Consultant displayed a general understanding of Department policies, processes, and procedures. Construction meetings were timely and proactively addressed potential construction issues. Construction issues were generally handled at the appropriate level and at the appropriate time. Field Division input was occasionally necessary to facilitate communication between the Consultant and construction contractor.
<b>Needs Improvement</b>	Consultant displayed an inability to effectively coordinate with the construction contractor. Consultant displayed a general lack of understanding of Department policies, processes, and procedures. Construction issues generally required involvement by the Field Division.
<b>Ability to Maintain Construction Schedule</b>	
<b>Exceeds Standards</b>	Consultant effectively maintained the project schedule. Correspondence and documentation was accurate and timely and displayed thorough understanding of issues that could impact project delivery. Consultant was proactive in identifying issues that could impact the delivery schedule, and provided possible solutions to potential problems before impacting the delivery schedule. Consultant displayed thorough understanding of construction issues and provided timely input to the contractor to help maintain the construction schedule. Coordinated at appropriate times with the Field Division to ensure decisions on construction issues would not impact the delivery date.
<b>Meets Standards</b>	Consultant effectively maintained the project schedule. Correspondence and documentation was displayed a general understanding of issues that could impact project delivery. Consultant was generally proactive in identifying issues that could impact the delivery schedule; occasional involvement by the Field Division was necessary to ensure the project delivery date was maintained. Consultant displayed a basic understanding of construction issues and provided input to the contractor to help maintain the construction schedule.
<b>Needs Improvement</b>	Consultant was unable to maintain the project schedule. Correspondence and documentation displayed a general lack of understanding of issues that could impact project delivery. Field Division involvement was frequently necessary to ensure the project delivery date was maintained. Consultant displayed a lack of basic understanding of construction issues.



**OKLAHOMA DEPARTMENT OF TRANSPORTATION  
TASK ORDER  
REQUEST FOR SERVICES**

Engineering Contract No.		Task Order No.	
Contract Project No.		Contract J/P No.	
Requested By:			
Consulting Firm:			
Method of Compensation:			
County:			
Construction Project No.:			
Construction Job Piece No.:			
Project Description:			
Services Description:			
Deliverables:			
Schedule to Complete Services:			

Signature Approval:

\_\_\_\_\_  
Division                      Date

\_\_\_\_\_  
Director of Engineering                      Date

**OKLAHOMA DEPARTMENT OF TRANSPORTATION  
CONSTRUCTION MANAGEMENT / INSPECTION TASK ORDER  
REQUEST FOR SERVICES**

Engineering Contract No.		Task Order No.	
Contract Project No.		Contract J/P No.	
Requested By:		ODOT Point Person:	
Consulting Firm:			
Method of Compensation:	<p>Hourly Rate as described in Section 3.2.3.3 of the Engineering Contract Number (shown above).</p> <p>Mileage will be compensated using the current IRS Rate and from the Department's closest Residency to the project location.</p>		
County:			
Construction Project No.:		Construction JP No.:	
Project Description:			
Services Description:	<p>Level (3) Services as described in the "Duties &amp; Responsibilities" Section for the Engineering Contract Number (shown above).</p>		
Deliverables:	<p>Record request shall be made available within agreed upon time table.</p> <p>All Pay Item Records will be submitted for Division Audit within 60 days after the project's completion date assignment. Division Audit discrepancies will be addressed and records returned to the Division Auditor within 30 days. Failure to meet these milestones will result in a daily penalty of One-Third (1/3) of the Construction Contract Liquidated Damage Daily Rate.</p> <p>Change Orders shall receive approval from the ODOT Resident Engineer prior to submittal to Assistant Division Engineer.</p>		
Contract Time:	Days	Project Construction Estimate	\$
Schedule to Complete Services:	<p>The Final Estimate Paperwork shall be delivered to _____ within (10) Days after the signed final estimate is received from the contractor.</p>		

Signature Approval:

---

 Division Engineer

Date

**CONSULTANT REQUEST FOR TASK ORDER APPROVAL**

<b>Submitted To:</b>
Oklahoma Department of Transportation Project Management Division 200 N.E. 21st Room 3-C9 Oklahoma City, OK 73105 Phone: (405)522-7601 Fax: (405)522-7612

<b>Submitted by:</b>	
Consultant Name	
Address	
City, State, Zip Code	
Phone	E-Mail
Fax	Address:
FEI #	

Engineering Contract Number	
Task Order Number	
Project Number	
Job Piece Number	
County	

**ATTACH A SEPARATE SHEET FOR FEE PROPOSAL**

<b>Scope of Work</b>
<p><b>Compensation Method:</b> _____</p>



**CONSTRUCTION MANAGEMENT / INSPECTION  
REQUEST FOR TASK ORDER APPROVAL**

<b>Submitted To:</b>
Oklahoma Department of Transportation Project Management Division 200 N.E. 21st Room 3-C9 Oklahoma City, OK 73105 Phone: (405)522-7601 Fax: (405)522-7612

<b>Submitted by:</b>			
Provider Name			
Address			
City, State, Zip Code			
Phone		E-Mail	
Fax		Address:	
FEI #			

Engineering Contract Number	
Task Order Number	
Project Number	
Job Piece Number	
County	

<b>Scope of Work</b>

APPENDIX 6.04.04

FEE PROPOSAL					
<b>Compensation Method:</b>			<b>Task Order Budget Total</b>		
Lump Sum:	\$ _____	Hourly:	\$ _____	\$ _____	
Cost Per Unit of Work:	\$ _____	Cost Plus Fixed Fee:	\$ _____		
Project Time Estimates:					
Construction Contract Time: _____			Complete by Date: _____		
Estimated Start Date: _____			Estimated Work Weeks: _____		
Project Labor:					
Classification:	Name of Personnel:	Hourly Rate:	Anticipated Overtime	Time on Project:	Total Cost:
Labor Total:					_____
Materials Testing					
Test Type	Quantity:	Unit:	Cost per Unit of Work:	Total:	
Testing Totals:					_____
Additional Project Expenses:					

<b>SCHEDULED DELIVERY DATE:</b>

<b>FIELD DIVISION APPROVAL</b>
--------------------------------

\_\_\_\_\_  
DIVISION ENGINEER DATE

<b>PROPOSAL APPROVAL:</b>
---------------------------

<b>FHWA APPROVAL</b>
----------------------

\_\_\_\_\_  
PROVIDER DATE

\_\_\_\_\_  
FHWA Signature DATE



**OKLAHOMA DEPARTMENT OF TRANSPORTATION**  
**200 N.E. 21<sup>st</sup> Street**  
**Oklahoma City, OK 73105-3204**

---

Date

Consultant Name  
Address  
City

RE: EC-\_\_\_\_\_ – Task Order No.\_\_\_\_\_ - Notice to Proceed

Dear \_\_\_\_\_:

\_\_\_\_\_ is authorized to begin work on the above-mentioned task order effective Date. Specifics of the task order are outlined in the enclosed executed task order approval. Please proceed at your earliest convenience.

If you have any questions, please contact me at (405) \_\_\_\_\_ - \_\_\_\_\_.

Sincerely,

Contract Administrator

c: Initiating Division

**CONSULTANT INVOICE**

<b>Submitted To:</b>
Attn: ConsultantClaims@odot.org
Oklahoma Department of Transportation
Project Management Division
200 N.E. 21st Room 3-C9
Oklahoma City, OK 73105
Phone: (405) 522-7606
Fax: (405) 522-7612

<b>Consultant Information</b>	
Consultant Information	
Submitted By:	
Address	
City, State, Zip Code	
Phone	
Fax	
FEI #	

Consultant Invoice#	
Payment#	
Date of Invoice	
Date of Last Invoice	

Engineering Contract #		Task Order #	
Engineering Job Piece #		Supplemental #	
Construction Job Piece #			
Project Description:			
Highway/County			

<b>Project Status for Invoice Amount (Attach additional sheets as necessary)</b>



APPENDIX 6.05.01

CONSULTANT INVOICE AMOUNTS AND APPROVALS

Project Description:

Hourly / Unit of Work

Name of Consultant or Sub-Consultant Providing Service	Note as P(Prime) or S(Sub)	Contract Component (service provided according to the executed contract)	Negotiated Not-to-Exceed Amount	Previously Paid to Date	Invoice Amount Requested	Resulting Contract Balance
<b>Totals</b>			<b>\$0.00</b>	<b>\$0.00</b>	<b>\$0.00</b>	<b>\$0.00</b>

Disallowed Amount	Amount Approved	Initials
<b>FOR ODOT USE ONLY</b>		

Lump Sum

Name of Consultant or Sub-Consultant Providing Service	Note as P(Prime) or S(Sub)	Contract Component (service provided according to the executed contract)	Negotiated Fee Amount	Total % Requested to Date	Total Requested to Date	Less Previously Paid to Date	Invoice Amount Requested	Total Disallowed Amount	Amount Approved	Initials
<b>Totals</b>			<b>\$0.00</b>	<b>0.00%</b>	<b>\$0.00</b>	<b>\$0.00</b>	<b>\$0.00</b>			<b>FOR ODOT USE ONLY</b>

<b>HOURLY / UNIT OF WORK TOTAL</b>	<b>\$0.00</b>
<b>LUMP SUM TOTAL</b>	<b>\$0.00</b>
<b>INVOICE TOTAL</b>	<b>\$0.00</b>

The activities of the consultant and the progress of the project appear largely consistent with the provisions of the task order or contract. Payments being authorized are subject to further validation during the task order or contract audit.

FOR ODOT USE ONLY			
APPROVAL	SIGNATURES	DATE	COMMENTS
Field Division			
Roadway Design			
Bridge Division			
Survey Division			
Environmental Programs Division			
Traffic Engineering Division			
Right-of-Way Division			
Local Government			

**SUPPLEMENTAL AND MODIFICATION AGREEMENT NO.  
TO PROVIDE ADDITIONAL ENGINEERING SERVICES UNDER  
AN ORIGINAL ENGINEERING CONTRACT NO.  
PRELIMINARY ENGINEERING PROJECT NO. [REDACTED]  
JOB NO. [REDACTED]  
COUNTY**

This Supplemental Agreement entered into by and between the Department of Transportation, acting for and on behalf of the State of Oklahoma and hereinafter referred to as the Department, and [REDACTED], referred to as the Consultant, said parties being the same who executed Engineering Contract No. [REDACTED]

**WITNESSETH:**

**WHEREAS**, it is deemed necessary by the Department and in order to provide additional [REDACTED], it is necessary to [REDACTED] to Engineering Contract No. [REDACTED].

The not to exceed compensation under Section 4.2 of the Engineering Contract shall be adjusted through this Supplemental Agreement No. [REDACTED].

Total Supplemental 1 Amount:	\$
Previous Contract Amount:	\$
Total Contract Amount:	\$

**WHEREAS**, the Consultant is directed to make the necessary changes noted above as part of Engineering Contract No. [REDACTED] and,

**WHEREAS**, under the terms of Section 6 Changes and Modifications, it was agreed that these revisions would be paid for by a Supplemental Agreement negotiated prior to performing the additional work.

**NOW, THEREFORE**, it is mutually agreed by and between the parties hereto:

- A. A not to exceed amount of \$ [REDACTED] shall be necessary for the revisions covered under this Supplemental Agreement No. 1.
- B. The Department will pay up to \$ [REDACTED] for additional services requested through Task Orders under the terms of this Supplemental Agreement No. 1.
- C. That Engineering Contract No. [REDACTED] is hereby modified as above described, said contract in all other respects be unchanged and in full force and effect.



**FOR PRESENTATION AT THE COMMISSION MEETING ON DATE**

**AGENDA ITEM NO:**

**SUBJECT: Supplemental Engineering Contract**

**County - Commission District Number (E.C. Number, Supplemental No. )**

The Transportation Commission had previously authorized \_\_\_\_\_ to prepare final design plans for the roadway and bridge project to upgrade \_\_\_\_\_. This supplement is for additional engineering services to incorporate the necessary design changes into the final construction plans.

EC-Number, Supplement No. – Consultant

Total Not to Exceed Amount                      \$ \_\_\_\_\_

This brings the total engineering contract cost, including this supplemental to \$ \_\_\_\_\_.

Funding will be with 80% Federal funds and 20% soft match credit.

**APPROVAL IS RECOMMENDED**

<b>Reporting Matrix for Scope Modifications and Changed Site Conditions</b>	
<b>Responsibility</b>	<b>Action</b>
O.D.O.T. Representative	Immediately notifies the Resident Engineer.
Resident Engineer	Informs the Assistant Field Division Engineer for Construction to determine the need for coordination with the Consulting Engineer of Record
Assistant Field Division Engineer for Construction	<p>Advises the Resident Engineer in the determination of the need for coordination with the Consulting Engineer of Record and, in the event that such coordination is necessary, acts as the point of initiation for contact with the Construction Division Engineer and the appropriate Department Engineering Manager, the Project Management Division, the Consultant, and the Federal Highway Administration.</p> <p style="text-align: center;"><b>-OR-</b></p> <p>If it is determined that no additional coordination with the Consulting Engineer of Record is necessary, insures that the decision is responsible and properly documented to the project record.</p>
O.D.O.T. Representative / Consulting Engineer	Consult either on site, or by other means as deemed appropriate, to define the required scope modification(s) and / or changed site condition(s) encountered and to determine the type of corrective action necessary.
Resident Engineer or Construction Division Engineer	Document and distribute the minutes of the conference outlining the discussion and outcome of the meeting. Incorporate the minutes into the permanent project record as the Determination of Appropriate Corrective Action Report.
Resident Engineer	Initiate the Department's customary change order preparation, negotiation, documentation and execution process. Resulting negotiations will be conducted in good faith based on the recommendations as documented in the Determination of Appropriate Corrective Action Report.
<b>For Scope Modifications and Changed Site Conditions, Transportation Commission approval and the subsequent ODOT processing of the change orders associated with the scope modification will constitute the successful resolution and the matter will be considered closed.</b>	

<b>Reporting Matrix for Design Errors and / or Omissions and Construction Management / Construction Inspection Errors and /or Omissions</b>	
<b>Responsibility</b>	<b>Action</b>
O.D.O.T. Representative	Immediately notifies the Resident Engineer.
Resident Engineer	Informs the Assistant Field Division Engineer for Construction to determine the need for coordination with the Consulting Engineer of Record
Assistant Field Division Engineer for Construction	<p>Advises the Resident Engineer in the determination of the need for coordination with the Consulting Engineer of Record and, in the event that such coordination is necessary, acts as the point of initiation for contact with the Construction Division Engineer and the appropriate Department Engineering Manager, the Project Management Division, the Consultant, and the Federal Highway Administration.</p> <p style="text-align: center;"><b>-OR-</b></p> <p>If it is determined that no additional coordination with the Consulting Engineer of Record is necessary, insures that the decision is responsible and properly documented to the project record.</p>
O.D.O.T. Representative / Consulting Engineer	Consult either on site, or by other means as deemed appropriate, to define the required scope modification(s) and / or changed site condition(s) encountered and to determine the type of corrective action necessary.
Resident Engineer or Construction Division Engineer	Document and distribute the minutes of the conference outlining the discussion and outcome of the meeting. Incorporate the minutes into the permanent project record as the Determination of Appropriate Corrective Action Report.
Resident Engineer	Initiate the Department's customary change order preparation, negotiation, documentation and execution process. Resulting negotiations will be conducted in good faith based on the recommendations as documented in the Determination of Appropriate Corrective Action Report.

APPENDIX 6.12.02

<p>Upon the successful negotiation of a change order, the following process should be initiated;</p>	
<p>Field Division representative / Construction Division Engineer / FHWA</p>	<p>Conference and prepare a written Determination of Consultant Liability for construction activities and / or construction delays resulting from errors or omissions.</p>
<p>Construction Division Engineer / Project Management</p>	<p>Prepare documentation encompassing all additional expenses incurred by the Department as a direct result of the error and / or omission including, but not limited to, overhead, profit, labor, equipment, materials, re-work, incidentals, user costs for additional time considerations (computed per day based on the contract liquidated damage amounts) and any contractor claims of delay. The documentation to be included in the Determination of Consultant Liability will not include the cost of construction activities which would be normally incurred as inherently necessary to properly construct the project elements in the absence of the error and / or omission.</p>
<p>Project Management Division</p>	<p>Compile the draft for Determination of Consultant Liability with supporting documentation and present to the Director of Operations and the Director of Engineering for approval.</p> <p style="text-align: center;"><b>- FOR DESIGN ERRORS AND OMISSIONS ONLY -</b></p>
<p>Director of Operations/ Project Management Division/ FHWA</p>	<p>Enter negotiations with the responsible Consultant and represent the interest of the Department to reach an appropriate monetary settlement in accordance with the Determination of Consultant Liability. Submit the final draft of the proposed settlement and related recommendation to the Director for review and approval for presentation for Transportation Commission consideration. In the event that satisfactory settlement cannot be reached, the matter will be referred to the General Counsel and Chief Engineer for further consideration and initiation of additional action and / or recourse</p>
<p>Director or Designee</p>	<p>Presents recommendation for Transportation Commission consideration</p>
<p>Director of Operations / Project Management Division</p>	<p>Facilitates the timely invoicing for and collection of payments in accordance with the Transportation Commission approved settlement and the applicable State and Federal Finance Policies and Procedures.</p>
<p>Project Management Division</p>	<p>Incorporate the final resolution into the responsible Consultant's permanent ODOT file. Errors and Omissions shall be included in the Consultant's project specific Performance Evaluation and considered as component of future selection processes.</p>





APPENDIX 9.01

**LPA Contract Monitoring**

The following items must be checked to ensure a Local Public Agency (LPA) receives Federal-aid reimbursement for engineering consulting services.

**Project Information**

Federal-aid Project No.:

Contract No.:

State Project No.:

Contracting Company:

Review Date:

Contract Length:

Review Made By:

Contract Value:

Solicitation/Selection By:

APPENDIX 9.01

<b>Solicitation Phase</b>			
Yes	No	N/A	
1)	<input type="checkbox"/>	<input type="checkbox"/>	<p>The LPA prepared a scope of work and cost estimate that reflects the consultant services that will be requested?</p> <p><i>(A preliminary scope of work and cost estimate must be prepared prior to issuing the solicitation.)</i></p>
2)			<p>Identify the type of services that will be performed</p> <ul style="list-style-type: none"> <li><input type="checkbox"/> NEPA</li> <li><input type="checkbox"/> Engineering Studies</li> <li><input type="checkbox"/> Preliminary Design</li> <li><input type="checkbox"/> Final Design</li> <li><input type="checkbox"/> Hydraulics</li> <li><input type="checkbox"/> Survey</li> <li><input type="checkbox"/> Geotechnical</li> <li><input type="checkbox"/> Construction Management</li> <li><input type="checkbox"/> Other: (Specify)</li> </ul>
3)	<input type="checkbox"/>	<input type="checkbox"/>	<p>The LPA obtained a list of consultants from the Oklahoma Department of Transportation for the categories of work required?</p> <p><i>(If a list was not obtained, explain how the consultants were identified and notified of the proposed work.)</i></p>
4)			<p>Were the following items included in the solicitation?</p> <ul style="list-style-type: none"> <li><input type="checkbox"/> <input type="checkbox"/> contract identification number</li> <li><input type="checkbox"/> <input type="checkbox"/> project number</li> <li><input type="checkbox"/> <input type="checkbox"/> location of work</li> <li><input type="checkbox"/> <input type="checkbox"/> brief scope of work</li> <li><input type="checkbox"/> <input type="checkbox"/> type of services</li> <li><input type="checkbox"/> <input type="checkbox"/> number of anticipated contracts (if multiple)</li> <li><input type="checkbox"/> <input type="checkbox"/> evaluation factors/questions</li> <li><input type="checkbox"/> <input type="checkbox"/> <input type="checkbox"/> DBE goal (if applicable) <i>(LPA should evaluate if DBE opportunities exist)</i></li> <li><input type="checkbox"/> <input type="checkbox"/> <input type="checkbox"/> specialized qualifications (if applicable)</li> <li><input type="checkbox"/> <input type="checkbox"/> anticipated start date</li> <li><input type="checkbox"/> <input type="checkbox"/> anticipated completion date</li> <li><input type="checkbox"/> <input type="checkbox"/> process for submitting response</li> <li><input type="checkbox"/> <input type="checkbox"/> agency point of contact</li> <li><input type="checkbox"/> <input type="checkbox"/> submission due date</li> </ul>
<b>"M"</b>	<b>"N"</b>		<b>Evaluation of the LPA Solicitation</b>
<input type="checkbox"/>	<input type="checkbox"/>		Completeness of the solicitation
<input type="checkbox"/>	<input type="checkbox"/>		Accuracy of the solicitation

APPENDIX 9.01

<b>Selection Phase</b>				
Yes	No	N/A		
5)	<input type="checkbox"/>	<input type="checkbox"/>	<p>The LPA appointed an appropriate selection committee.</p> <p><i>(The selection committee should have 3 to 5 members which may include LPA staff, elected officials, and at least one member with technical expertise; i.e. a licensed professional engineer or architect. The selection committee may add a non-voting member from the Oklahoma Department of Transportation staff to act as a resource.)</i></p>	
6)	<input type="checkbox"/>	<input type="checkbox"/>	<p>The LPA performed an appropriate evaluation and ranking of the submitted proposals to develop a "short list".</p> <p><i>(Short list must contain a minimum of three consultants. Evaluation and ranking must be based on the evaluation factors/questions identified in the solicitation. The same evaluation factors/questions must be used for all of the proposals.)</i></p>	
7)	<input type="checkbox"/>	<input type="checkbox"/>	<input type="checkbox"/>	<p>If a DBE goal has been set, consultants must document their good faith effort to meet the goal.</p> <p><i>(Documentation should include: a list of DBE firms contacted, a list of DBE firms that responded with a subcontract proposal, and if the consultant does not propose to use a DBE firm that submitted a subcontract proposal, and explanation why such DBE firm will not be used.)</i></p>
8)	<input type="checkbox"/>	<input type="checkbox"/>	<p>The LPA interviewed and ranked the "short list".</p> <p><i>(Evaluation and final ranking must be based on the evaluation factors/questions identified in the solicitation. The same evaluation factors/questions must be used for all of the proposals.)</i></p>	
<b>"M"</b>	<b>"N"</b>		<b>Evaluation of the LPA Selection Process and Documentation</b>	
<input type="checkbox"/>	<input type="checkbox"/>		Appropriate application of the selection process and documentation	
<input type="checkbox"/>	<input type="checkbox"/>		Accuracy of the selection process documentation	

APPENDIX 9.01

Contract Development Phase			
	Yes	No	N/A
9)	<input type="checkbox"/>	<input type="checkbox"/>	
	<p>The LPA entered into negotiation with the highest-ranking consultant.</p> <p><i>(If the LPA and consultant were unable to agree on a fair and equitable fee for their services, the LPA may cease negotiations with that consultant and begin negotiations with the second most qualified consultant. If the LPA was unable to agree with that firm, the LPA would move to the third consultant in a similar fashion. If the LPA was unable to agree on a price with that firm, the LPA is required to open up the selection criteria to more firms.)</i></p>		
10)	<input type="checkbox"/>	<input type="checkbox"/>	
	<p>Was the highest-ranking consultant selected?</p>		
11)	<input type="checkbox"/>	<input type="checkbox"/>	<input type="checkbox"/>
	<p>Written justification must be included in the project file if negotiations failed with the highest-ranking consultant.</p>		
12)	<input type="checkbox"/>	<input type="checkbox"/>	
	<p>The LPA informed those consultants that submitted proposals of the selection process results.</p>		
13)	<input type="checkbox"/>	<input type="checkbox"/>	
	<p>Final Contract Cost Proposal sheets included in the project file?</p> <p><i>(Includes cost for the prime and all first tier sub-consultants.)</i></p>		
14)	<input type="checkbox"/>	<input type="checkbox"/>	<input type="checkbox"/>
	<p>If multiple Contracts were executed, do the number of Contracts executed equal the number of anticipated Contracts identified in the solicitation?</p>		
15)	<input type="checkbox"/>	<input type="checkbox"/>	
	<p>If the number of Contracts executed are not equal the number of anticipated Contracts identified in the solicitation is Department approval documented in the file?</p>		
16)	<input type="checkbox"/>	<input type="checkbox"/>	
	<p>Is the Contract scope of services consistent with the brief scope of work included in the solicitation?</p>		
17)	<input type="checkbox"/>	<input type="checkbox"/>	<input type="checkbox"/>
	<p>DBE commitment equals or exceeds the DBE goal?</p>		
18)	<input type="checkbox"/>	<input type="checkbox"/>	
	<p>Is the negotiated fee on the Contract Cost Proposal sheets the same as the fee in the Contract?</p> <p><i>(Verify that the contract amount equals the total negotiated fee. Total negotiated fee is typically based on lump sum, cost plus fixed fee, or hourly rates.)</i></p>		
19)	<input type="checkbox"/>	<input type="checkbox"/>	
	<p>Hourly rates and multiplier same between Contract Cost Proposal sheet and Form B-3.</p> <p><i>(Required for the prime and all first tier sub-consultants with hourly contracts only.)</i></p>		

APPENDIX 9.01

**Contract Development Phase Continued**

- |     | Yes                      | No                       | N/A  |
|-----|--------------------------|--------------------------|--|
| 20) | <input type="checkbox"/> | <input type="checkbox"/> | If subcontracting is used, was the Key Personnel Form B1 for all First Tier Sub-Consultants included?  |
| 21) | <input type="checkbox"/> | <input type="checkbox"/> | If subcontracting is used, was a First Tier Sub-Consultant Participation Form B2 completed including a list of sub-consultants, work to be performed, estimated fees and DBE status? |
| 22) | <input type="checkbox"/> | <input type="checkbox"/> | All deliverables including reasonable milestone dates are included in the Contract?  |
| 23) |                          |                          | The following federal-aid requirements are included in the Contract?   |
|     | <input type="checkbox"/> | <input type="checkbox"/> | Certification of Consultant  |
|     | <input type="checkbox"/> | <input type="checkbox"/> | Certification of LPA   |
|     | <input type="checkbox"/> | <input type="checkbox"/> | US DOT Certification for Federal-aid Contracts   |
|     | <input type="checkbox"/> | <input type="checkbox"/> | US DOT Certification of Eligibility  |
|     | <input type="checkbox"/> | <input type="checkbox"/> | Title VI of the Civil Rights Act of 1964   |
|     | <input type="checkbox"/> | <input type="checkbox"/> | US DOT Certification for Federal-aid Contracts Drug Free Workplace   |
|     | <input type="checkbox"/> | <input type="checkbox"/> | Disadvantaged Business Enterprises Policy Statement  |
|     | <input type="checkbox"/> | <input type="checkbox"/> | Federal Highway Administration Contract Requirements   |
|     | <input type="checkbox"/> | <input type="checkbox"/> | Certificate of Final Indirect Costs  |

- | "M"                      | "N"                      |   |
|--------------------------|--------------------------|---|
|                          |                          | <b>Evaluation of the LPA Contract Development Process and Documentation</b>   |
| <input type="checkbox"/> | <input type="checkbox"/> | Appropriate application of the contract development process and documentation |
| <input type="checkbox"/> | <input type="checkbox"/> | Accuracy of the contract development documentation                            |

"M" = Meets Expectations & "N" = Needs Improvement

Explanation and/ or additional comments (if necessary):



**OKLAHOMA DEPARTMENT OF TRANSPORTATION**  
**200 N.E. 21<sup>st</sup> Street**  
**Oklahoma City, OK 73105-3204**

---

**DATE:**

**TO: LPA**

**FROM: Local Government Division**

**SUBJECT: LPA Request to Solicit**

The Department has reviewed the proposed LPA Solicitation of Interest for EC-\_\_\_\_ through EC-\_\_\_\_ and found that it is complete and accurate. Therefore, the Department concurs with your request to issue the solicitation of interest.

**CONCURRENCE:** \_\_\_\_\_

Local Government

Date



**OKLAHOMA DEPARTMENT OF TRANSPORTATION**  
**200 N.E. 21<sup>st</sup> Street**  
**Oklahoma City, OK 73105-3204**

---

**DATE:**

**TO: LPA**

**FROM: Local Government Division**

**SUBJECT: LPA Request to Select**

The Department has reviewed the LPA scoring documents for EC-\_\_\_\_ and found that it is complete and accurate. Therefore, the Department concurs with your request to select and endorses proceeding to the contract development phase.

**CONCURRENCE:** \_\_\_\_\_

Local Government

Date



**OKLAHOMA DEPARTMENT OF TRANSPORTATION**  
**200 N.E. 21<sup>st</sup> Street**  
**Oklahoma City, OK 73105-3204**

---

**DATE:**

**TO: LPA**

**FROM: Local Government Division**

**SUBJECT: LPA Contract Delegation**

The Department has reviewed the contracting process conducted by LPA for EC-\_\_\_\_ through EC-\_\_\_\_ and found that the \_\_\_\_\_ phase is consistently complete and accurate. Therefore, the Department delegates the \_\_\_\_\_ phase to the LPA. The Department will continue to monitor the delegated phase to ensure continual compliance.

**REVIEWER:** \_\_\_\_\_

Local Government

Date





**OKLAHOMA DEPARTMENT OF TRANSPORTATION**  
**200 N.E. 21<sup>st</sup> Street**  
**Oklahoma City, OK 73105-3204**

---

**DATE:**

**TO: LPA**

**FROM: Local Government Division**

**SUBJECT: LPA Contract Delegation Renewal**

The Department has reviewed the delegated process conducted by LPA and found that the \_\_\_\_\_ phase for EC-\_\_\_\_ is in compliance. Therefore, the Department is renewing the delegation for the \_\_\_\_\_ phase to the LPA. The Department will continue to monitor the delegated phase to ensure continual compliance.

**REVIEWER:** \_\_\_\_\_

Local Government

Date



**OKLAHOMA DEPARTMENT OF TRANSPORTATION**  
**200 N.E. 21<sup>st</sup> Street**  
**Oklahoma City, OK 73105-3204**

---

**DATE:**

**TO: LPA**

**FROM: Local Government Division**

**SUBJECT: LPA Contract Delegation Removal**

The Department has reviewed the delegated process conducted by LPA and found that the \_\_\_\_\_ phase for EC-\_\_\_\_ is not in compliance. Therefore, the Department is removing the delegation for the \_\_\_\_\_ phase from the LPA. The Department will review and assist the LPA for this phase of the contracting process on future Federal-aid contracts. Training opportunities are available if the LPA desires to reestablish this delegation in the future.

**REVIEWER:** \_\_\_\_\_

Local Government

Date

## CONTRACT ADMINISTRATION WBS

ID	Task Name
1	<b>CONSULTANT SOLICITATION PROCESS</b>
2	JUSTIFICATION FOR PROFESSIONAL SERVICES CONTRACTS
3	Determine if ODOT resource allocation requires outsourcing
4	Determine if services require specialized expertise
5	Verify funding type and availability
6	Obtain necessary approvals
7	<b>CONTRACT FILE PREPARATION</b>
8	Create and maintain contract file
9	<b>GENERAL SCOPE OF SERVICES DEVELOPMENT</b>
10	Develop scope of services
11	Identify type of contracts for solicitation
12	<b>SOLICITATION OF INTEREST</b>
13	Prepare the solicitation of interest (SOI)
14	Set schedule for the SOI
15	Develop evaluation criteria
16	Obtain required services/project information
17	Prepare consultant instructions for submission of letters of interest (LOI)
18	Solicit consultant interest
19	Transmit request for letters of interest via email
20	Update website to include the solicitation packet
21	<b>CONSULTANT RESPONSE</b>
22	Receive letters of interest (LOI)
23	Log receipt of LOIs
24	Update website to include the letters of interest
25	Prepare selection committee packets
26	Place LOIs in document vault
27	<b>CONSULTANT SELECTION PROCESS</b>
28	<b>SHORT-LIST DEVELOPMENT</b>
29	Department consultant selection committee determination
30	Determine composition of selection committee
31	Obtain recommendation and approval of selection committee
32	Letters of interest/Response packet evaluations
33	Notify committee members of document vault location
34	Evaluate LOIs
35	Develop composite scores
36	Reach consensus on short list of consultants
37	Obtain approvals
38	Establish tentative schedule for interviews
39	Notify consultants of short list
40	Prepare and send letters to non-short listed consultants
41	Notify short listed consultants
42	Update website to include the short listed consultants
43	Schedule interviews
44	<b>TECHNICAL PROPOSAL - INTERVIEW PRESENTATION</b>
45	Prepare request for technical proposal
46	Establish interview format
47	Send interview notice to consultants
48	<b>SCOPE OF SERVICES CLARIFICATION</b>
49	Provide scope clarification to consultants as requested
50	<b>INTERVIEW EVALUATION</b>
51	Conduct interviews
52	Evaluate consultants
53	Develop composite scores
54	Identify highest ranked consultant(s)
55	Obtain approvals
56	Notify consultants of results
57	Update website to include the selected consultants
58	Maintain documentation of process in file
59	<b>DEBRIEFING CONSULTANTS NOT SELECTED</b>
60	Meet with consultants to explain the selection process as requested
61	<b>CONTRACT DEVELOPMENT</b>
62	<b>DETAILED SCOPE OF WORK</b>
63	Obtain supporting information from consultant
64	<b>PRE-NEGOTIATION</b>

## CONTRACT ADMINISTRATION WBS

ID	Task Name
65	Schedule pre-negotiation scope meeting
66	Conduct pre-negotiation scope meeting
67	Clarify role of ODOT and consultant
68	Refine scope
69	Schedule negotiation meeting
70	<b>FEE PROPOSAL</b>
71	Describe services
72	Request revised scope and fee from consultant
73	Conduct internal meeting to discuss proposed scope and fees
74	Determine fee structure
75	<b>OVERHEAD RATES</b>
76	Request certified overhead rates from consultants
77	Receive certified overhead rates from consultants
78	<b>NEGOTIATION</b>
79	Discuss tasks and sub-tasks, deliverables and formats
80	Discuss overhead rates and base multipliers
81	Discuss subconsultants
82	Confirm final scope and fees
83	Request final scope and fee proposal
84	<b>FINAL FEE PROPOSAL</b>
85	Receive and confirm final scope and fee proposal
86	Develop contract components
87	For standard contracts use boilerplate template
88	For special service contract write contract as necessary
89	Create attachments
90	Compile contract
91	Modify contract in accordance with revisions from the negotiations
92	Incorporate special requirements
93	Include time for performance
94	Include compensation
95	Prepare attachments
96	Incorporate scope of work
97	Add baseline schedule
98	Incorporate progressive payment provisions
99	Add key personnel; subconsultant participation and hourly and overhead rates
100	Include federal-aid requirements
101	Review contract file to ensure all necessary documentation has been obtained
102	<b>TRANSPORATION COMMISSION APPROVAL</b>
103	Prepare agenda item
104	Obtain Assistant Chief Engineer approval
105	Submit agenda item to Secretary's Office
106	Conduct agenda meeting
107	Conduct commission meeting
108	<b>EXECUTION OF THE CONTRACT</b>
109	Send consultant's final scope to FHWA for review (full oversight FA projects only)
110	Obtain contract signatures
111	<b>FEDERAL AUTHORIZATION</b>
112	Obtain federal authorization of funds
113	<b>CONTRACT ALLOTMENT ESTABLISHMENT</b>
114	Request authority for expenditure - point of service & demand service
115	Submit request for expenditure to Comptroller
116	Comptroller verifies allotment availability
117	Comptroller submits request form to CPO for purchase order
118	CPO sets up PO in PeopleSoft
119	CPO returns request form back to Comptroller with PO number
120	Comptroller encumbers funds for contract
121	Comptroller enters information into FMS
122	Request authority for expenditure - construction management
123	Submit unencumbered contract to Comptroller
124	Comptroller files contract and waits for task order
125	Submit request for expenditure for task order to Comptroller
126	Comptroller verifies allotment availability
127	Comptroller submits request form to CPO for purchase order
128	CPO sets up PO in PeopleSoft

## CONTRACT ADMINISTRATION WBS

ID	Task Name
129	CPO returns request form back to Comptroller with PO number
130	Comptroller encumbers funds for task order
131	Comptroller enters information into FMS
132	<b>NOTICE TO PROCEED</b>
133	Send a notice to proceed to the consultant
134	<b>CONTRACT ADMINISTRATION</b>
135	<b>MONITORING AND CONTROL</b>
136	Oversee, supervise and manage the consultant during the preconstruction development
137	<b>CONSULTANT EVALUATIONS</b>
138	Evaluate performance at milestones
139	Document evaluations
140	<b>STOP WORK NOTIFICATION</b>
141	In the event it becomes necessary send written notification to consultant to stop work
142	<b>TASK ORDERS</b>
143	Prepare task orders - demand service
144	Determine need for task order
145	Obtain approvals
146	Submit task order request for services to PMD
147	Request consultant to complete the request for task order approval form
148	Consultant submits request for task order approval and fee proposal
149	Verify funding for task order
150	Submit to requesting party for approval
151	Approve/Reject scope & fee proposal
152	If rejected contact consultant for revisions
153	Consultants submits revisions
154	Review and approve revisions
155	Obtain approvals
156	Submit approvals to PMD
157	Send notice to proceed letter, signed task order & fee approval to consultant
158	Provide copy of notice to proceed to project manager
159	Maintain electronic file
160	Prepare task orders - construction management
161	Determine need for task order
162	Submit task order request for services to PMD
163	Request consultant to complete the request for task order approval form
164	Consultant submits request for task order approval and fee proposal
165	Verify funding for task order
166	Submit to requesting party for approval
167	Approve/Reject proposal
168	If rejected contact consultant for revisions
169	Consultants submits revisions
170	Review and approve revisions
171	Submit approvals to PMD
172	Submit task order to Comptroller for authorization of expenditure
173	Send notice to proceed letter, signed task order & fee approval to consultant
174	Maintain electronic file
175	<b>INVOICE PROCEDURES</b>
176	Receive invoices from consultants
177	Validate invoices
178	Submit invoice and supporting documentation to ODOT representatives
179	Audit claim
180	Determine any disallowances
181	Enter claim into PeopleSoft
182	Comptroller processes the claim
183	OSF issues warrant to consultant
184	Forward all documents to Comptroller Division for final disposition
185	Maintain electronic file
186	<b>SUPPLEMENTING ENGINEERING CONTRACTS</b>
187	Justify modifications and need for supplement
188	Obtain approvals
189	Negotiate scope and associated fees
190	Conduct agenda process
191	Prepare agenda item
192	Obtain Director of Engineering approval

**CONTRACT ADMINISTRATION WBS**

ID	Task Name
193	Submit agenda item to Secretary's Office
194	Conduct agenda meeting
195	Conduct commission meeting
196	Prepare contract modification and supplemental agreement
197	Maintain electronic file
198	<b>CONTRACT CLOSEOUT</b>
199	Receive final invoice
200	Request contract audit from OR&E Division
201	Process final payment request
202	Perform final consultant evaluation
203	Submit letter to request contract closing to comptroller
204	Maintain electronic file

# CONTRACT ADMINISTRATION PROCESS

