

STATE OF OKLAHOMA
DEPARTMENT OF TRANSPORTATION

PLAN OF PROPOSED

STATE HIGHWAY

FEDERAL AID PROJECT NO. NHPPI-0035-3(125)121
GRADING, DRAINAGE, SURFACING & EROSION CONTROL PLANS
INTERSTATE HIGHWAY NO. I-240 & I-35

OKLAHOMA COUNTY

INDEX OF SHEETS

SHEET NO.	DESCRIPTION
1.	TITLE SHEET
2.	INDEX OF SHEETS

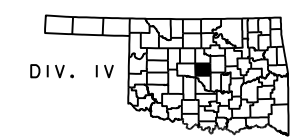

LOCATION MAP

DESIGN EXCEPTION INCLUDE:
SHOULDER WIDTH
STOPPING SIGHT DISTANCE
(HORIZ.)

FOR SURVEY CONTROL DATA
SEE SURVEY DATA SHEETS

BRIDGE LENGTHS

BRIDGE A	STA. 79+77.81 1059'-10 5/8"
BRIDGE C	STA. 426+61.18 320'-6"
BRIDGE D	STA. 429+81.68 320'-6"
BRIDGE L	STA. 412+26.92 413'-6"

DESIGN DATA

EXPRESSWAY	= 55 MPH
SERVICE ROADS	= 40 MPH
CROSS STREETS	= 40 MPH
RAMPS (DIRECT)	= 50 MPH
RAMPS (LOOPS)	= 25 MPH
RAMPS (SEMI-DIRECT)	= 45 MPH

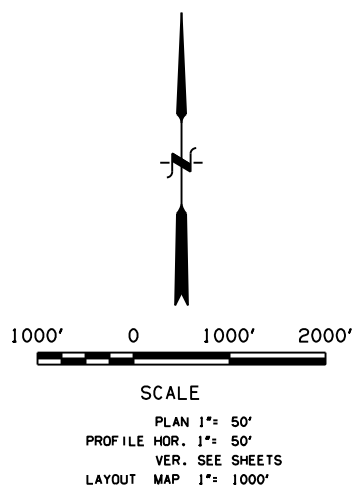

- CONVENTIONAL SIGNS
- INTERSTATE HIGHWAY
 - U.S. HIGHWAY
 - STATE HIGHWAY
 - PROPOSED ROAD
 - RAILROADS
 - RANGE & TOWNSHIP LINES
 - SECTION LINES
 - QUARTER SECTION LINES
 - FENCES
 - GROUND LINE
 - EXISTING ROADS
 - BASE LINE
 - GRADE LINES
 - TELEPHONE & TELEGRAPH
 - POWER LINES
 - OIL WELLS
 - BUILDINGS
 - DRAINAGE STRUCTURES-IN-PLACE
 - DRAINAGE STRUCTURES-NEW
 - RIGHT-OF-WAY LINES-EXISTING
 - RIGHT-OF-WAY LINES-NEW
 - RIGHT-OF-WAY MARKERS-IN PLACE
 - RIGHT-OF-WAY MARKERS-REMOVE & RESET
 - RIGHT-OF-WAY MARKERS-NEW
 - CONTROLLED ACCESS
 - EXISTING SANITARY SEWERS
 - EXISTING GAS LINES
 - EXISTING WATER LINES
 - EXISTING TELEPHONE CABLES UNDERGROUND

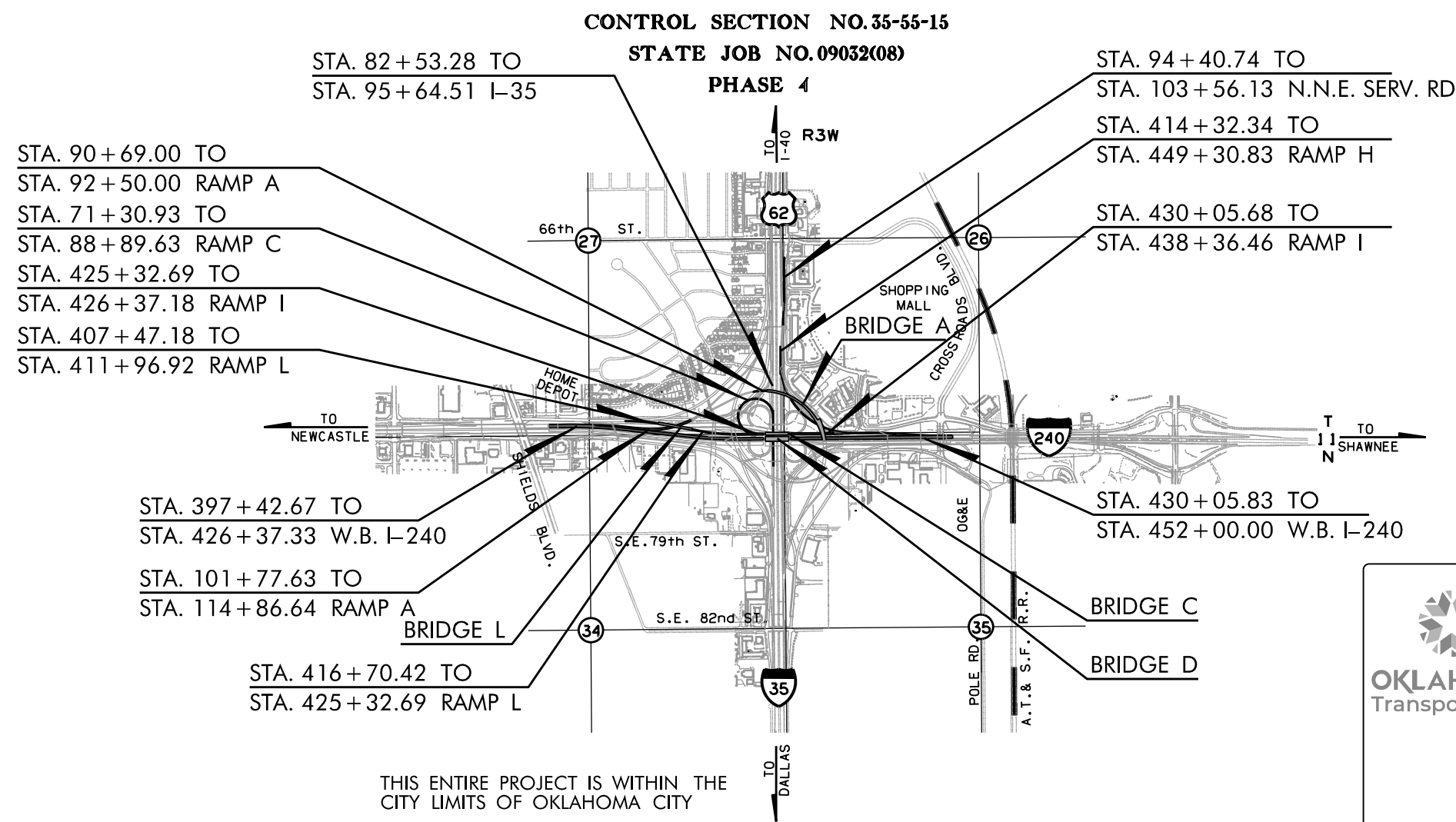

THIS ENTIRE PROJECT IS WITHIN THE
CITY LIMITS OF OKLAHOMA CITY

ROADWAY LENGTH	16,313.79 FT.	3.090 MILES
BRIDGE LENGTH	2,114.39 FT.	0.400 MILES
PROJECT LENGTH	18,428.18 FT.	3.490 MILES
EQUATION: SEE GEOMETRIC SHEETS		
EXCEPTIONS:		

PREPARED AND SUBMITTED BY:

PE POE & ASSOCIATES INC.
Oklahoma City, Oklahoma
CA NO. 541

THOMAS S. EVANS, P.E.
OKLA. REG. NO. 25204

MICHAEL S. LETTNER, P.E., S.E.
OKLA. REG. NO. 24224

THOMAS S. EVANS, P.E. 25204
MICHAEL S. LETTNER, P.E., S.E. 24224

OKLAHOMA Transportation

OKLAHOMA DEPARTMENT OF TRANSPORTATION

DEPARTMENT OF TRANSPORTATION FEDERAL HIGHWAY ADMINISTRATION

DATE APPROVED _____

DATE APPROVED _____

BY _____

BY _____

CHIEF ENGINEER DIVISION ADMINISTRATOR

SWO 2923(1) FEDERAL AID PROJECT NO. NHPPI-0035-3(125)121 SHEET NO. 0001

2:33:50 PM H:\PROJECTS\2789_Crossroads_Phase 4\Roadway\Drawings\0903208-Phase 4-TitleSht.dgn

**90% PLAN
SUBMITTAL**

3/12/2024

INDEX OF SHEETS

0001 TITLE SHEET
0002 INDEX OF SHEETS
0003-0027 TYPICAL SECTIONS
AB01-AB08 SUMMARY OF PAY QUANTITIES & NOTES (BRIDGE)
AR01-AR02 SUMMARY OF PAY QUANTITIES & NOTES (ROADWAY)
AR03-AR12 SUMMARY SHEETS
AT01 SUMMARY OF PAY QUANTITIES (TRAFFIC OPERATIONS)
AT02 SUMMARY OF PAY QUANTITIES & NOTES (SIGN & STRIPING)
AT03 SUMMARY OF PAY QUANTITIES & NOTES (LIGHTING)

BRIDGE "A"

B001 BRIDGE "A" SEQUENCE MAP AND SHEET INDEX
B002-B004 GENERAL PLAN & ELEVATION
B005 DESIGN DATA AND SUMMARY OF QUANTITIES
B006-B009 FOUNDATION REPORT
B010-B011 SUBSTRUCTURE LAYOUT
B012 EXCAVATION DIAGRAMS AND UNDERDRAIN DETAILS
B013-B014 ABUTMENT DETAILS
B015-B029 PIER DETAILS
B030-B033 PIER PROTECTION AND BARRIER TRANSITION DETAILS
B034-B040 SUPERSTURCTURE DETAILS
B041-B042 LONGITUDINAL SECTION AND SLAB POURING SEQUENCE
B043-B046 PARAPET LAYOUT
B047 END BARRIER LAYOUT
B048 GIRDER BRACING DETAILS
B049-B058 PLATE GIRDER DETAILS
B059-B061 FRAMING PLAN AND DIAPHRAGM DETAILS
B062 BEARING ASSEMBLY DETAILS
B063-B064 APPROACH SLAB DETAILS
B065-B066 SLOPE WALL DETAILS
B067 DRAIN AT END OF BRIDGE DETAILS

BRIDGE "C"

B068 GENERAL PLAN & ELEVATION
B069 DESIGN DATA AND SUMMARY OF QUANTITIES
B070-B071 FOUNDATION REPORT
B072 SUBSTRUCTURE LAYOUT
B073 ABUTMENT EXCAVATION AND UNDERDRAIN DETAILS
B074-B076 ABUTMENT DETAILS
B077-B079 PIER DETAILS
B080-B081 PIER PROTECTION DETAILS
B082-B083 BARRIER TRANSITION DETAILS
B084-B086 SUPERSTURCTURE DETAILS
B087 LONGITUDINAL SECTION AND DIAPHRAGM DETAILS
B088 PARAPET LAYOUT
B089-B090 TYPE IV P.C.B. DETAILS
B091 BEARING ASSEMBLY DETAILS
B092-B093 APPROACH SLAB DETAILS
B094-B095 SLOPEWALL DETAILS
B096-B097 DRAINS AT END OF BRIDGE DETAILS

BRIDGE "D"

B098 GENERAL PLAN & ELEVATION
B099 DESIGN DATA AND SUMMARY OF QUANTITIES
B100 BRIDGE CONSTRUCTION SEQUENCE
B101-B103 FOUNDATION REPORT
B104 SUBSTRUCTURE LAYOUT
B105 ABUTMENT EXCAVATION AND UNDERDRAIN DETAILS
B106-B108 ABUTMENT DETAILS
B109-B111 PIER DETAILS
B112-B113 PIER PROTECTION DETAILS
B114-B115 MEDIAN BARRIER TRANSITION DETAILS
B116-B119 SUPERSTURCTURE DETAILS
B120 LONGITUDINAL SECTION AND DIAPHRAGM DETAILS
B121 PARAPET LAYOUT
B122-B123 MEDIAN BARRIER DETAILS
B124-B125 TYPE IV P.C.B. DETAILS
B126 BEARING ASSEMBLY DETAILS
B127-B128 APPROACH SLAB DETAILS
B129-B130 SLOPEWALL DETAILS

BRIDGE "L"

B131 GENERAL PLAN & ELEVATION
B132 DESIGN DATA AND SUMMARY OF QUANTITIES
B133-B134 FOUNDATION REPORT
B135 SUBSTRUCTURE LAYOUT
B136 EXCAVATION DIAGRAMS AND UNDERDRAIN DETAILS
B137 ABUTMENT FOOTING DETAILS
B138 ABUTMENT WING SUPPORT DETAILS
B139-B144 ABUTMENT DETAILS
B145-B146 PIER DETAILS
B147-B152 SUPERSTURCTURE DETAILS
B153-B154 PARAPET LAYOUT
B155 MISCELLANEOUS PRESTRESSING DETAILS
B156-B157 APPROACH SLAB DETAILS
B158 SLOPE WALL DETAILS
B159 DRAIN AT END OF BRIDGE DETAILS
B160 ARCHITECTURAL TREATMENT DETAILS AND SUPPERSTR. PLACING SEQUENCE

ROADWAY

R001 STORM WATER MANAGEMENT PLAN
R002-R004 DRAINAGE STRUCTURE DESIGN RECORD
R005-R026 DRAINAGE AREA MAP
R027 OVERVIEW MAP
R028 GENERAL SEQUENCE OF CONSTRUCTION
R029-R030 ULTIMATE FACILITY TRAFFIC DATA
R031-R032 GEOMETRIC LAYOUT SHEETS
R033-R044 GEOMETRIC COORDINATE POINT TABLES
R045-R066 PLAN AND PROFILE SHEETS
R067-R086 EROSION CONTROL SHEETS
R087-R095 JOINT LAYOUT SHEETS
R096-R101 REMOVALS PHASE 4 CONSTRUCTION
R102-R107 SPOT ELEVATIONS
R108 F-SHAPE PARAPET AND MOMENT SLAB DETAIL
R109 TEMPORARY INLET SEDIMENT FILTER
R110 DETAIL OF CURB INLET W/ JUNCTION BOX
R111-R113 PIER PROTECTION AND BARRIER TRANSITION DETAILS
R114-R115 MEDIAN BARRIER AND DRILLED SHAFT DETAILS
R116-R117 MEDIAN BARRIER TRANSITION DETAILS
R118 MEDIAN BARRIER SPECIAL TRANSITION DETAILS

RETAINING WALLS

RW01 RETAINING WALL LOCATION MAP & SUMMARY OF QUANTITIES
RW02 M.S.E. RETAINING WALL 'D2' PLAN & ELEVATION
RW03 FOUNDATION REPORT-RETAINING WALL 'D2'
RW04 M.S.E. RETAINING WALL 'F' PLAN & ELEVATION
RW05 FOUNDATION REPORT-RETAINING WALL 'F'
RW06 M.S.E. RETAINING WALL 'G' PLAN & ELEVATION
RW07 FOUNDATION REPORT-RETAINING WALL 'G'
RW08 M.S.E. RETAINING WALL 'H' PLAN & ELEVATION
RW09-RW11 FOUNDATION REPORT-RETAINING WALL 'H'
RW12 M.S.E. RETAINING WALL NOTES
RW13 M.S.E. RETAINING WALL DETAILS
RW14 SOIL NAIL RETAINING WALL 'I' PLAN & ELEVATION
RW15-RW19 FOUNDATION REPORT-RETAINING WALL 'I'
RW20 SOIL NAIL RETAINING WALL 'I' SPECIFICATIONS
RW21 SOIL NAIL RETAINING WALL 'I' HORIZONTAL ALIGNMENT LAYOUT
RW22-RW25 SOIL NAIL RETAINING WALL 'I' LAYOUT
RW26-RW27 SOIL NAIL RETAINING WALL 'I' DETAILS

SURVEY DATA

S001-S046 SURVEY DATA SHEETS

TRAFFIC CONTROL

T001-T009 TRAFFIC CONTROL PHASE 1
T010-T019 TRAFFIC CONTROL PHASE 2

TRAFFIC SIGN & STRIPING

T020 SIGNING SCHEDULE
T021-T031 SPECIAL SIGN DETAILS
T032 ROUTE ASSEMBLY AND VERTICAL CLEARANCE SIGNS
T033-T035 SIGN STRUCTURE DETAILS
T036 SIGNING & STRIPING SHEET LAYOUT MAP
T037-T044 I-240 SIGNING AND STRIPING
T045-T054 I-35 SIGNING AND STRIPING
T055-T058 RAMP A SIGNING AND STRIPING
T059 LIGHTING SCHEDULE
T060-T063 LIGHTING PLAN
T064 I-35 UNDERPASS LIGHTING PLAN

CROSS SECTIONS

X001-X101 CROSS SECTION - CRL I-240 W.B.
X102-X116 CROSS SECTION - ϕ I-35 WIDENING
X117-X149 CROSS SECTION - RAMP A
X150-X178 CROSS SECTION - RAMP C
X179-X232 CROSS SECTION - RAMP H
X233-X245 CROSS SECTION - RAMP I
X246-X247 CROSS SECTION - RAMP L
X273-X288 CROSS SECTION - N.N.E. SERV. RD.
X289-X302 CROSS SECTION - CHANNEL C
X303-X306 CROSS SECTION - CHANNEL C-1
X307-X310 CROSS SECTION - CHANNEL C-2
X311-X313 CROSS SECTION - CHANNEL C-3

THE FOLLOWING ODOT
STANDARDS WILL BE REQUIRED:

ROADWAY:
(2019)

BMPR-0
TESCA-0
IPD-0
RSF-0
TSD-0
TFL-0
TRFD-0
SCE-0
CWA-0
SSS-2-1
CSCD-6-2
LECS-5-2
LTU-5-1
CRCP1-4-1
PED-4-1
PSE-2-1
PSMD-2-2
SMD-4-2
PCE5-5-1
SSCD-4-1

BRIDGE:
(2009)

RCB-C1-8(2-14)-01E
RCB-E1-H4-0-1-01E
RCB-E1-H4-0-2-01E
EJ-DTL-02E
EJ-SK-04E
EJ-SQ-04E
FSHP-41-2-00E
HP1-2-01E

LIGHTING:
(2009)

CCD1-1-00
CCD2-1-00
PBD1-1-00
GMF1-2-01
BMF1-2-00
BMF2-2-00
BMF3-2-00
HLBP1-1-01
HLGN1-1-01
HLPD1-1-00
PMBD1-1-00

TRAFFIC
OPERATIONS:
(2009)

TCS2-1-00
TCS3-1-01
TCS4-1-01
TCS5-1-00
TCS6-1-02
TCS7-1-02
TCS8-1-00
TCS9-1-01
TCS10-1-00
TCS11-1-01

SIGNING
& STRIPING:
(2009)

PM1-1-03
PM4-1-02
PM5-1-00
PM6-1-00
PM7-1-00
DU1-1-00
DU2-1-00
RSD1-1-00
RSD2-1-00
WSD1-1-00
WSD2-1-00
WSD3-1-00
MSD1-00
MSD2-1-00
MSD3-1-01
MSD4-1-00
MSD5-1-00

DESIGN	-	-	PHASE 4	OKLAHOMA COUNTY
DRAWN	-	-	INDEX OF SHEETS STATE JOB NO. <u>09032108</u> SHEET NO. <u>0002</u>	
CHECKED	-	-		
APPROVED	-	-		
SQUAD	POE			

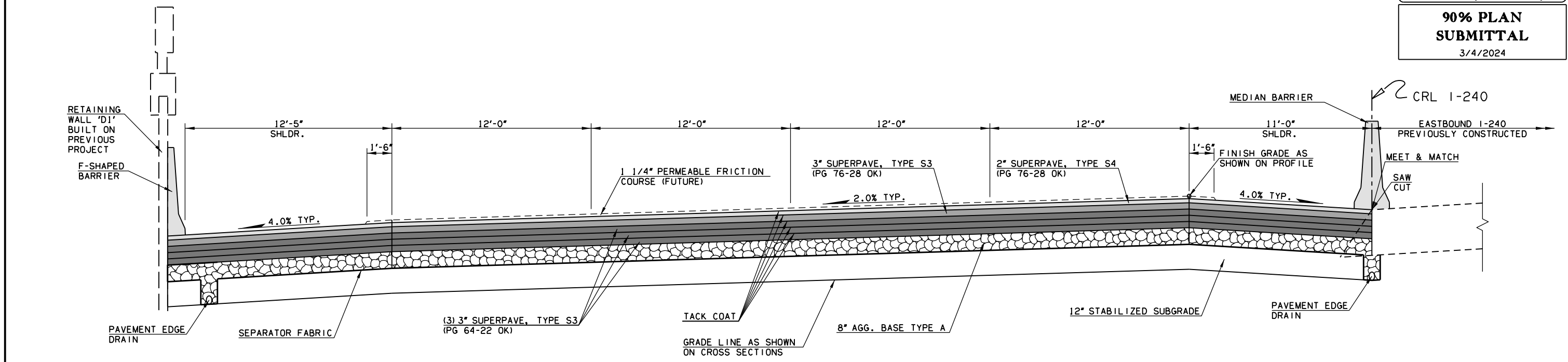

① **TYPICAL SECTION
WESTBOUND I-240**
STA. 397+24.67 TO STA. 398+40.00

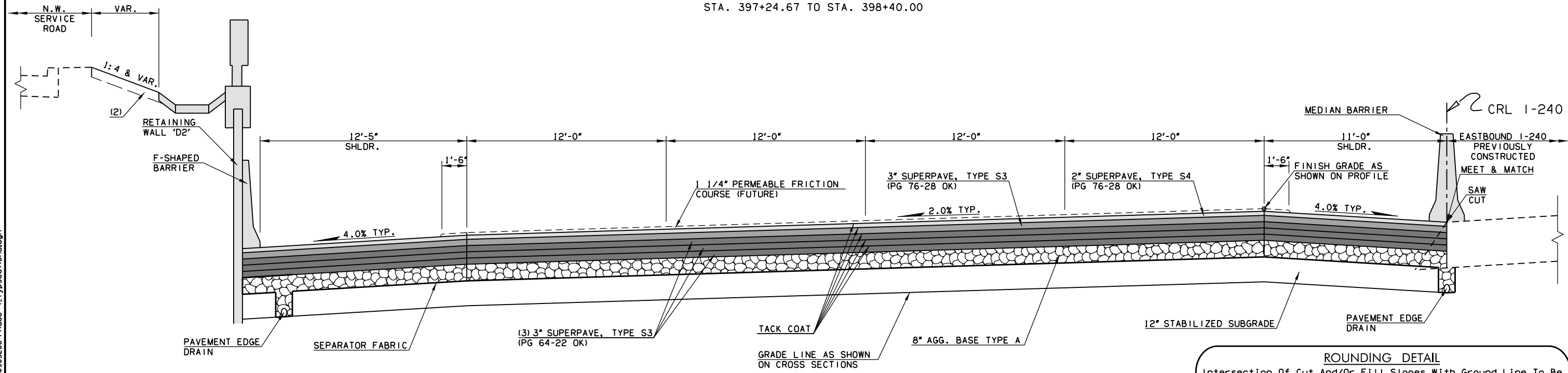

▲ **STATION EQUATION**
STA. 400+00.00 ~ CRL I-240 BK=
STA. 399+96.14 ~ CRL I-240 AHD

② **TYPICAL SECTION
WESTBOUND I-240**
▲ STA. 398+40.00 TO STA. 401+00.00

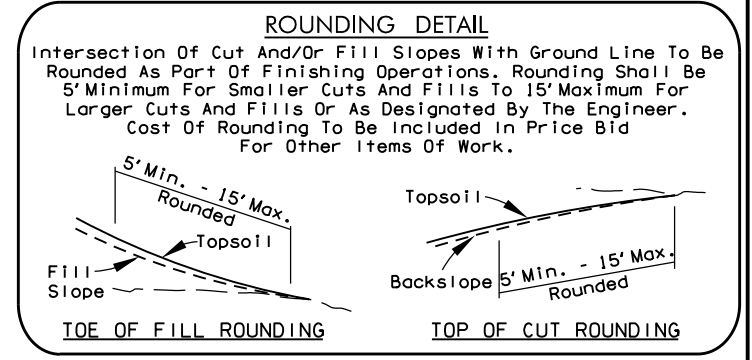

(1) TO BE BACKFILLED AND COMPACTED AS PART OF FINISHING OPERATIONS. QUANTITY IS MEASURED IN UNCLASSIFIED BORROW.

(2) **TOPSOIL NOTE:**
THE CONTRACTOR SHALL STRIP ALL OF THE AVAILABLE TOPSOIL, STOCKPILE IT, AND PLACE IT BACK ON THE SECTION IN ACCORDANCE WITH SECTION 205 OF THE STANDARD SPECIFICATIONS. RESERVED TOPSOIL SHALL BE SPREAD FIRST ON THE COMPLETED SLOPES OF THE CUT SECTIONS AND THE REMAINDER ON COMPLETED FILL SLOPES OR OTHER PRIORITY AREAS LOCATED BY THE ENGINEER. ALL ADDITIONAL COSTS ASSOCIATED WITH OPERATION SHALL BE INCLUDED IN THE PAY ITEM FOR SALVAGED TOPSOIL, LUMP SUM.

(3) INTERSECTION OF CUT AND/OR FILL SLOPES WITH GROUND LINE TO BE ROUNDED AS PART OF FINISHING OPERATIONS. ROUNDED SHALL BE 5' MIN. FOR SMALLER CUTS AND FILLS, TO 15' MAX. FOR LARGER CUTS AND FILLS, OR AS DESIGNATED BY THE ENGINEER. COST OF ROUNDED TO BE INCLUDED IN PRICE BID FOR OTHER ITEMS OF WORK. SEE ROUNDED DETAIL ON THIS TYPICAL SHEETS.

(4) TO BE BACKFILLED AND COMPACTED AS PART OF FINISHING OPERATIONS. QUANTITY IS MEASURED IN T.B.S.C. TYPE E.

DESIGN	-	-	PHASE 4	OKLAHOMA COUNTY
DRAWN	-	-	TYPICAL SECTIONS (WESTBOUND I-240)	
CHECKED	-	-		
APPROVED	-	-		
SQUAD	POE		STATE JOB NO. 09032108	SHEET NO. 0003

3/4/2024 2:33:54 PM H:\PROJECTS\2789_CrossRoads_Phase 4\Roadway\Drawings\0903208-Phase 4_TypSections.dgn

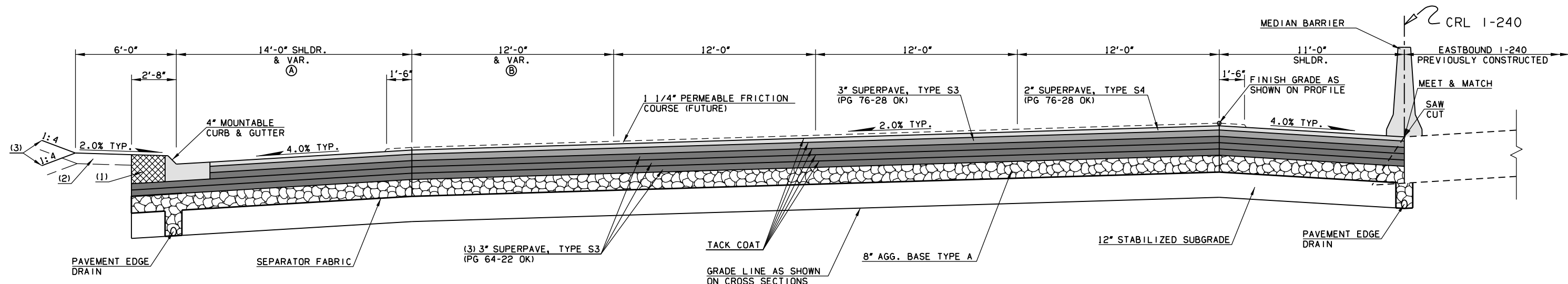

3 TYPICAL SECTION
WESTBOUND I-240
STA. 401+00.00 TO STA. 403+49.63
STA. 435+90.60 TO STA. 443+42.25

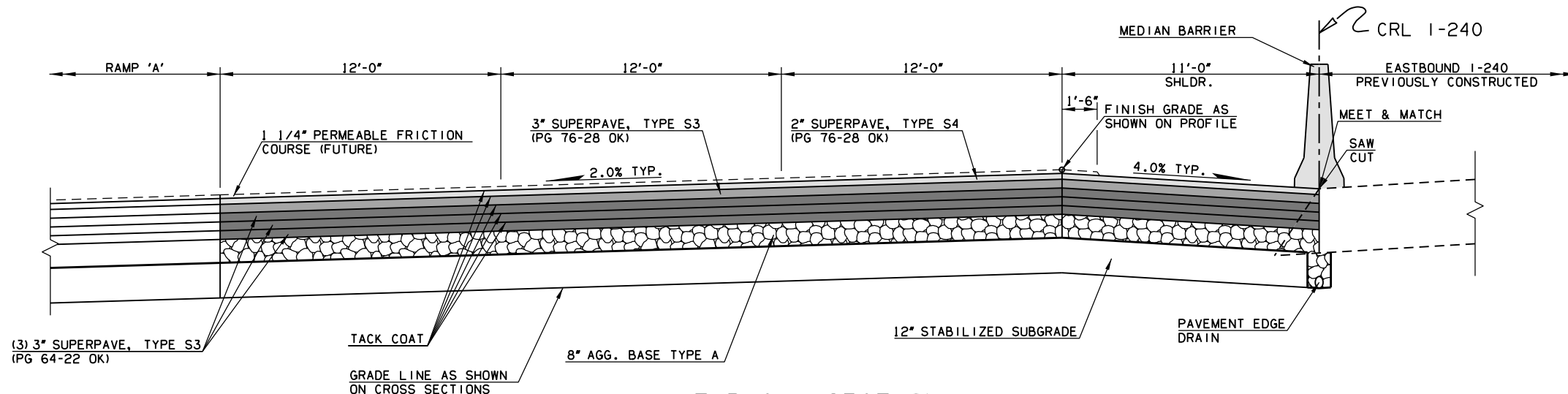

4 TYPICAL SECTION
WESTBOUND I-240
STA. 403+49.63 TO STA. 412+30.70

SEGMENT	VARIABLE WIDTH	STATION EXTENTS
A	14'-0"	401+00.00 TO 401+41.63
A	14'-0" TO 10'-0"	401+41.63 TO 402+11.63
A	10'-0"	402+11.63 TO 403+49.63
A	10'-0"	435+90.60 TO 443+42.25
B	12'-0"	401+00.00 TO 403+49.63
B	0'-0" TO 10'-9"	435+90.60 TO 443+42.25

NOTE: VAR. NOT SHOWN SEE PLANS/DETAILS FOR MORE INFORMATION

(1) TO BE BACKFILLED AND COMPACTED AS PART OF FINISHING OPERATIONS. QUANTITY IS MEASURED IN UNCLASSIFIED BORROW.

(2) **TOPSOIL NOTE:**
THE CONTRACTOR SHALL STRIP ALL OF THE AVAILABLE TOPSOIL, STOCKPILE IT, AND PLACE IT BACK ON THE SECTION IN ACCORDANCE WITH SECTION 205 OF THE STANDARD SPECIFICATIONS. RESERVED TOPSOIL SHALL BE SPREAD FIRST ON THE COMPLETED SLOPES OF THE CUT SECTIONS AND THE REMAINDER ON COMPLETED FILL SLOPES OR OTHER PRIORITY AREAS LOCATED BY THE ENGINEER. ALL ADDITIONAL COSTS ASSOCIATED WITH OPERATION SHALL BE INCLUDED IN THE PAY ITEM FOR SALVAGED TOPSOIL, LUMP SUM.

(3) INTERSECTION OF CUT AND/OR FILL SLOPES WITH GROUND LINE TO BE ROUNDED AS PART OF FINISHING OPERATIONS. ROUNDED SHALL BE 5' MIN. FOR SMALLER CUTS AND FILLS, TO 15' MAX. FOR LARGER CUTS AND FILLS, OR AS DESIGNATED BY THE ENGINEER. COST OF ROUNDED TO BE INCLUDED IN PRICE BID FOR OTHER ITEMS OF WORK. SEE ROUNDED DETAIL ON OTHER TYPICAL SHEETS.

(4) TO BE BACKFILLED AND COMPACTED AS PART OF FINISHING OPERATIONS. QUANTITY IS MEASURED IN T.B.S.C. TYPE E.

DESIGN	-	-	PHASE 4	OKLAHOMA COUNTY
DRAWN	-	-	TYPICAL SECTIONS (WESTBOUND I-240)	
CHECKED	-	-		
APPROVED	-	-		
SQUAD	POE		STATE JOB NO. 09032108	SHEET NO. 0004

3/4/2024 2:33:55 PM H:\PROJECTS\2789_CrossRoads_Phase 4\Roadway\Drawings\09032108-Phase 4_TypSections.dgn

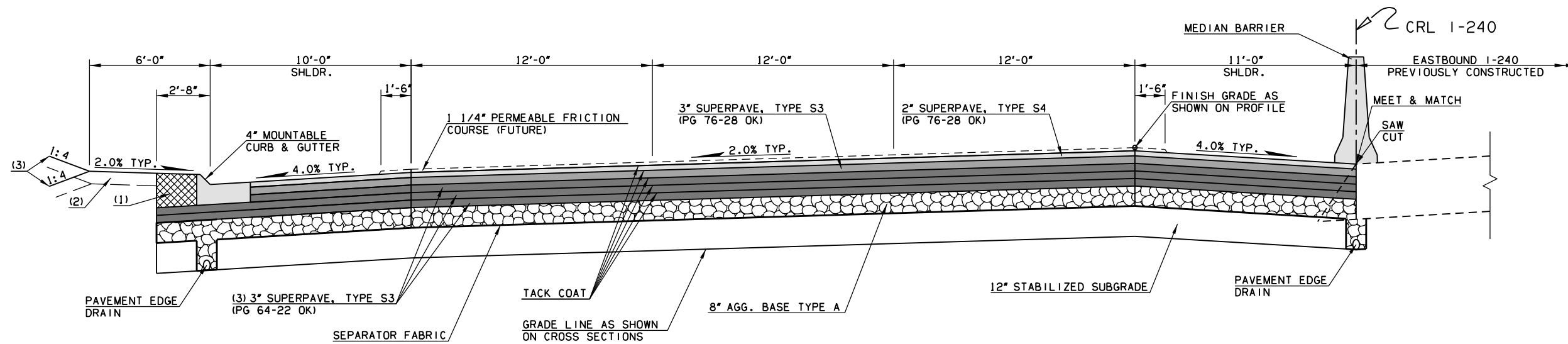

5 TYPICAL SECTION
WESTBOUND I-240
STA. 412+30.70 TO STA. 426+37.33
STA. 434+59.79 TO STA. 435+90.60

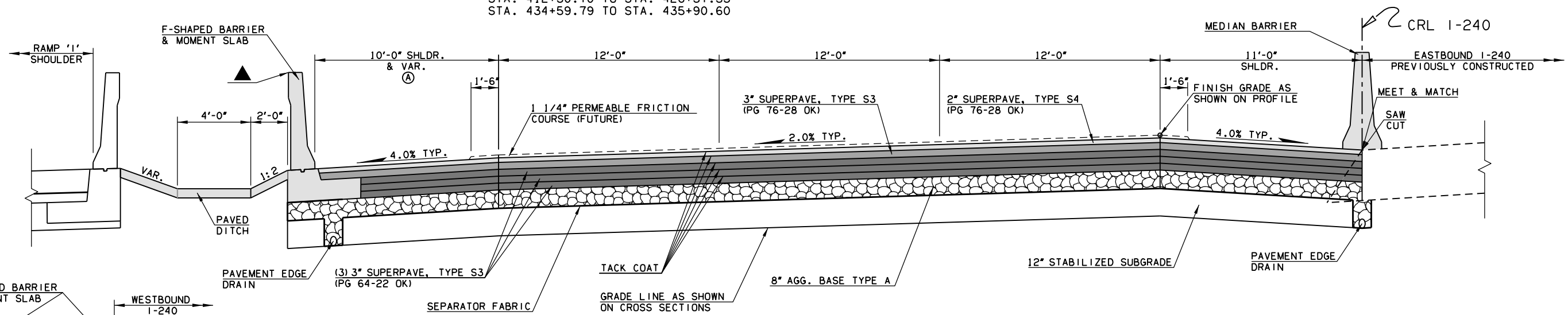

6 TYPICAL SECTION
WESTBOUND I-240
STA. 430+05.83 TO STA. 434+59.79

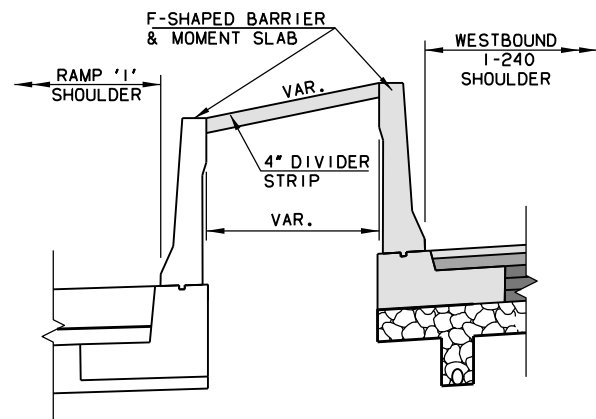

TYPICAL SECTION
WESTBOUND I-240
DIVIDER STRIP
STA. 432+36.00 TO STA. 434+36.87

(1) TO BE BACKFILLED AND COMPACTED AS PART OF FINISHING OPERATIONS. QUANTITY IS MEASURED IN UNCLASSIFIED BORROW.

(2) **TOPSOIL NOTE:**

THE CONTRACTOR SHALL STRIP ALL OF THE AVAILABLE TOPSOIL, STOCKPILE IT, AND PLACE IT BACK ON THE SECTION IN ACCORDANCE WITH SECTION 205 OF THE STANDARD SPECIFICATIONS. RESERVED TOPSOIL SHALL BE SPREAD FIRST ON THE COMPLETED SLOPES OF THE CUT SECTIONS AND THE REMAINDER ON COMPLETED FILL SLOPES OR OTHER PRIORITY AREAS LOCATED BY THE ENGINEER. ALL ADDITIONAL COSTS ASSOCIATED WITH OPERATION SHALL BE INCLUDED IN THE PAY ITEM FOR SALVAGED TOPSOIL, LUMP SUM.

(3) INTERSECTION OF CUT AND/OR FILL SLOPES WITH GROUND LINE TO BE ROUNDED AS PART OF FINISHING OPERATIONS. ROUNDED SHALL BE 5' MIN. FOR SMALLER CUTS AND FILLS, TO 15' MAX. FOR LARGER CUTS AND FILLS, OR AS DESIGNATED BY THE ENGINEER. COST OF ROUNDED TO BE INCLUDED IN PRICE BID FOR OTHER ITEMS OF WORK. SEE ROUNDED DETAIL ON OTHER TYPICAL SHEETS.

(4) TO BE BACKFILLED AND COMPACTED AS PART OF FINISHING OPERATIONS. QUANTITY IS MEASURED IN T.B.S.C. TYPE E.

SEGMENT	VARIABLE WIDTH	STATION EXTENTS
A	10'-0" TO 19'-0"	430+05.83 TO 434+59.79

NOTE: VAR. NOT SHOWN SEE PLANS/DETAILS FOR MORE INFORMATION

DESIGN	-	-	PHASE 4	OKLAHOMA COUNTY
DRAWN	-	-	TYPICAL SECTIONS (WESTBOUND I-240)	
CHECKED	-	-		
APPROVED	-	-		
SQUAD	POE		STATE JOB NO. 09032108	SHEET NO. 0005

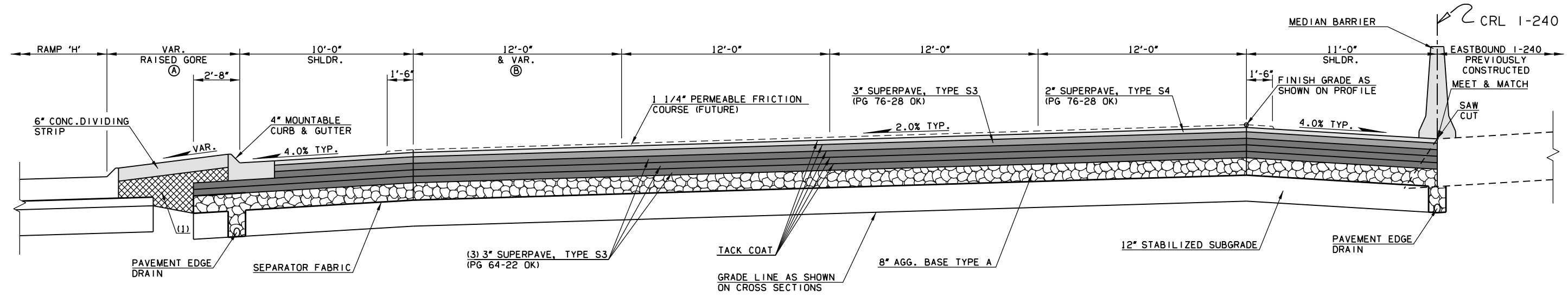

7 TYPICAL SECTION
WESTBOUND I-240
STA. 443+42.25 TO STA. 443+80.70

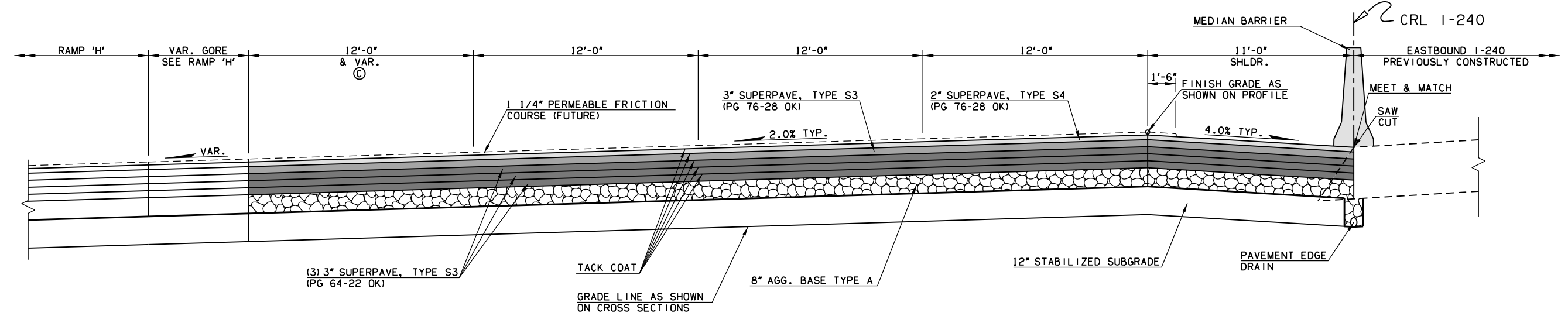

8 TYPICAL SECTION
WESTBOUND I-240
STA. 443+80.70 TO STA. 449+30.83

SEGMENT	VARIABLE WIDTH	STATION EXTENTS
A	10'-0" TO 4'-0"	443+42.25 TO 443+80.70
B	10'-9" TO 11'-3"	443+42.25 TO 443+80.70
C	11'-3" TO 12'-0"	443+80.70 TO 444+30.67
C	12'-0"	444+30.67 TO 449+30.83

NOTE: VAR. NOT SHOWN SEE PLANS/DETAILS FOR MORE INFORMATION

(1) TO BE BACKFILLED AND COMPACTED AS PART OF FINISHING OPERATIONS. QUANTITY IS MEASURED IN UNCLASSIFIED BORROW.

(2) **TOPSOIL NOTE:**
THE CONTRACTOR SHALL STRIP ALL OF THE AVAILABLE TOPSOIL, STOCKPILE IT, AND PLACE IT BACK ON THE SECTION IN ACCORDANCE WITH SECTION 205 OF THE STANDARD SPECIFICATIONS. RESERVED TOPSOIL SHALL BE SPREAD FIRST ON THE COMPLETED SLOPES OF THE CUT SECTIONS AND THE REMAINDER ON COMPLETED FILL SLOPES OR OTHER PRIORITY AREAS LOCATED BY THE ENGINEER. ALL ADDITIONAL COSTS ASSOCIATED WITH OPERATION SHALL BE INCLUDED IN THE PAY ITEM FOR SALVAGED TOPSOIL, LUMP SUM.

(3) INTERSECTION OF CUT AND/OR FILL SLOPES WITH GROUND LINE TO BE ROUNDED AS PART OF FINISHING OPERATIONS. ROUNDED SHALL BE 5' MIN. FOR SMALLER CUTS AND FILLS, TO 15' MAX. FOR LARGER CUTS AND FILLS, OR AS DESIGNATED BY THE ENGINEER. COST OF ROUNDED TO BE INCLUDED IN PRICE BID FOR OTHER ITEMS OF WORK. SEE ROUNDED DETAIL ON OTHER TYPICAL SHEETS.

(4) TO BE BACKFILLED AND COMPACTED AS PART OF FINISHING OPERATIONS. QUANTITY IS MEASURED IN T.B.S.C. TYPE E.

DESIGN	-	-	PHASE 4	OKLAHOMA COUNTY
DRAWN	-	-	TYPICAL SECTIONS (WESTBOUND I-240)	
CHECKED	-	-		
APPROVED	-	-		
SQUAD	POE		STATE JOB NO. 09032108	SHEET NO. 0006

3/4/2024 2:33:56 PM H:\PROJECTS\2789_CrossRoads_Phase 4\Roadway\Drawings\0903208-Phase 4_TypSections.dgn

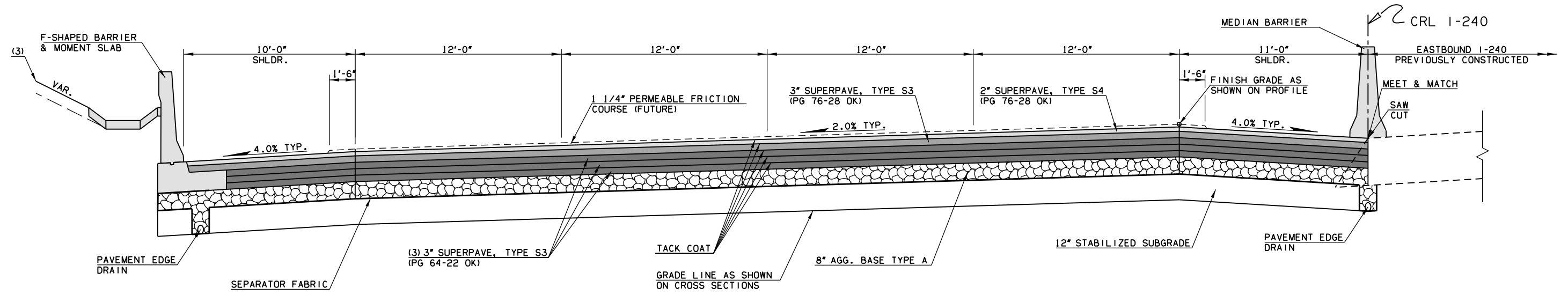

9 TYPICAL SECTION
WESTBOUND I-240
STA. 449+30.83 TO STA. 449+95.41
STA. 450+76.71 TO STA. 452+00.00

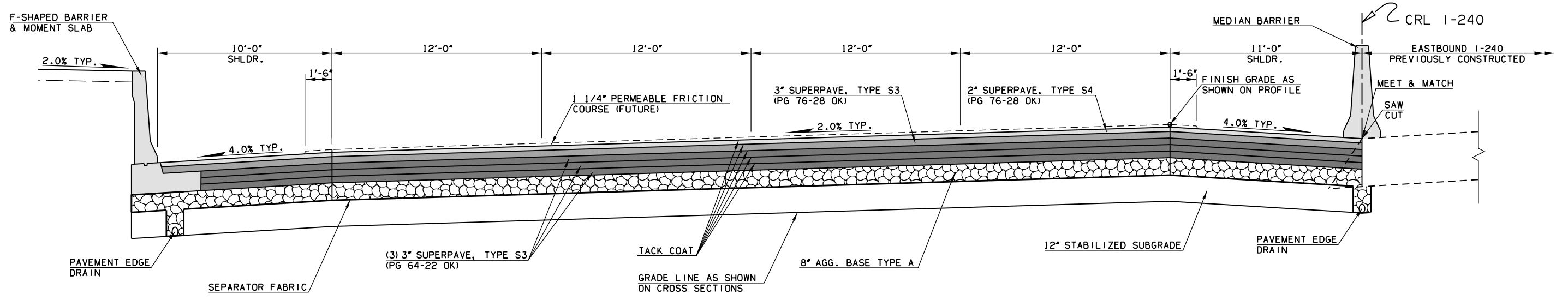

10 TYPICAL SECTION
WESTBOUND I-240
STA. 449+95.41 TO STA. 450+76.71

- (1) TO BE BACKFILLED AND COMPACTED AS PART OF FINISHING OPERATIONS. QUANTITY IS MEASURED IN UNCLASSIFIED BORROW.
- (2) **TOPSOIL NOTE:**
THE CONTRACTOR SHALL STRIP ALL OF THE AVAILABLE TOPSOIL, STOCKPILE IT, AND PLACE IT BACK ON THE SECTION IN ACCORDANCE WITH SECTION 205 OF THE STANDARD SPECIFICATIONS. RESERVED TOPSOIL SHALL BE SPREAD FIRST ON THE COMPLETED SLOPES OF THE CUT SECTIONS AND THE REMAINDER ON COMPLETED FILL SLOPES OR OTHER PRIORITY AREAS LOCATED BY THE ENGINEER. ALL ADDITIONAL COSTS ASSOCIATED WITH OPERATION SHALL BE INCLUDED IN THE PAY ITEM FOR SALVAGED TOPSOIL, LUMP SUM.
- (3) INTERSECTION OF CUT AND/OR FILL SLOPES WITH GROUND LINE TO BE ROUNDED AS PART OF FINISHING OPERATIONS. ROUNDED SHALL BE 5' MIN. FOR SMALLER CUTS AND FILLS, TO 15' MAX. FOR LARGER CUTS AND FILLS, OR AS DESIGNATED BY THE ENGINEER. COST OF ROUNDED TO BE INCLUDED IN PRICE BID FOR OTHER ITEMS OF WORK. SEE ROUNDED DETAIL ON OTHER TYPICAL SHEETS.
- (4) TO BE BACKFILLED AND COMPACTED AS PART OF FINISHING OPERATIONS. QUANTITY IS MEASURED IN T.B.S.C. TYPE E.

DESIGN	-	-	PHASE 4	OKLAHOMA COUNTY
DRAWN	-	-	TYPICAL SECTIONS (WESTBOUND I-240) STATE JOB NO. 09032108 SHEET NO. 0007	
CHECKED	-	-		
APPROVED	-	-		
SQUAD	POE			

3/4/2024 2:33:57 PM H:\PROJECTS\2789_CrossRoads_Phase 4\Roadway\Drawings\0903208-Phase 4_TypSections.dgn

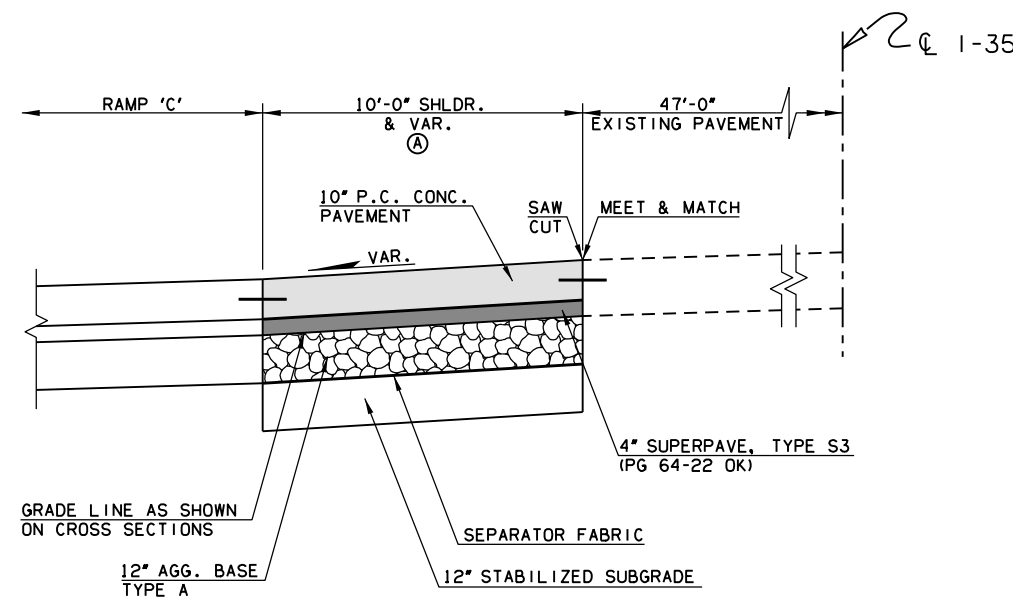

11 TYPICAL SECTION
I-35 WIDENING
STA. 82+53.28 TO STA. 82+93.82

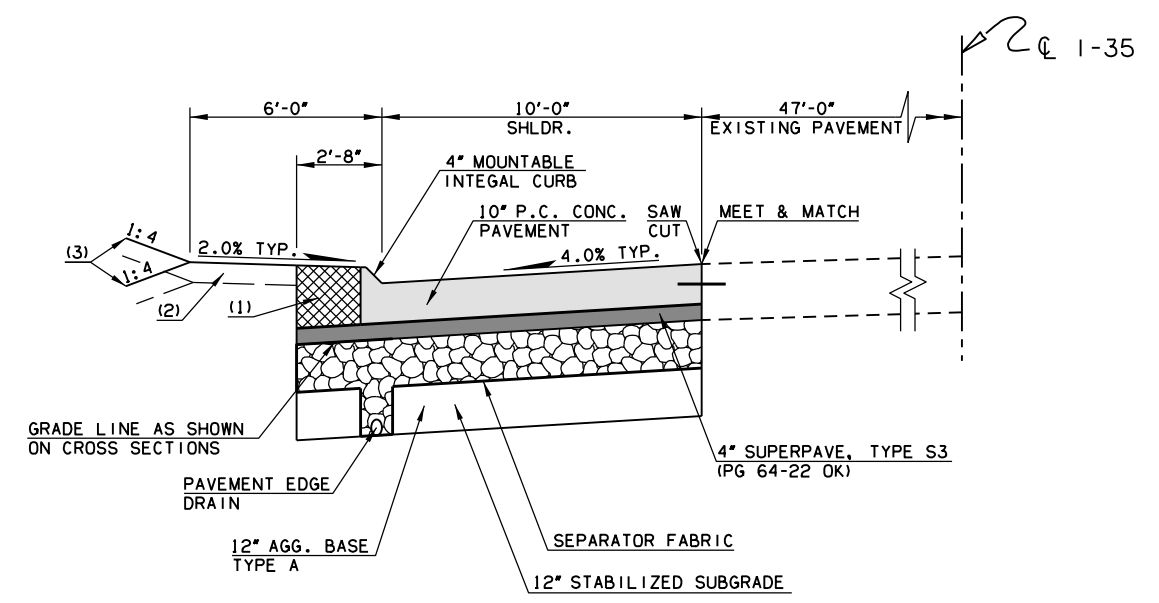

13 TYPICAL SECTION
I-35 WIDENING
STA. 83+29.00 TO STA. 87+83.85

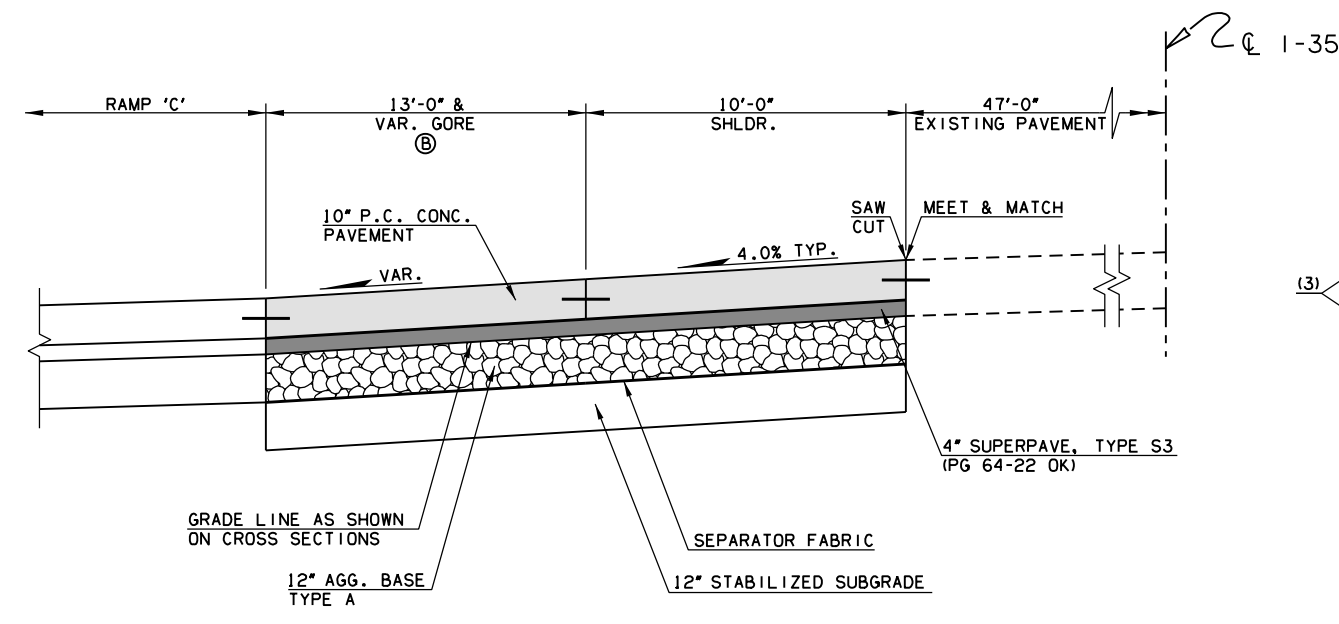

12 TYPICAL SECTION
I-35 WIDENING
STA. 82+93.82 TO STA. 83+29.00

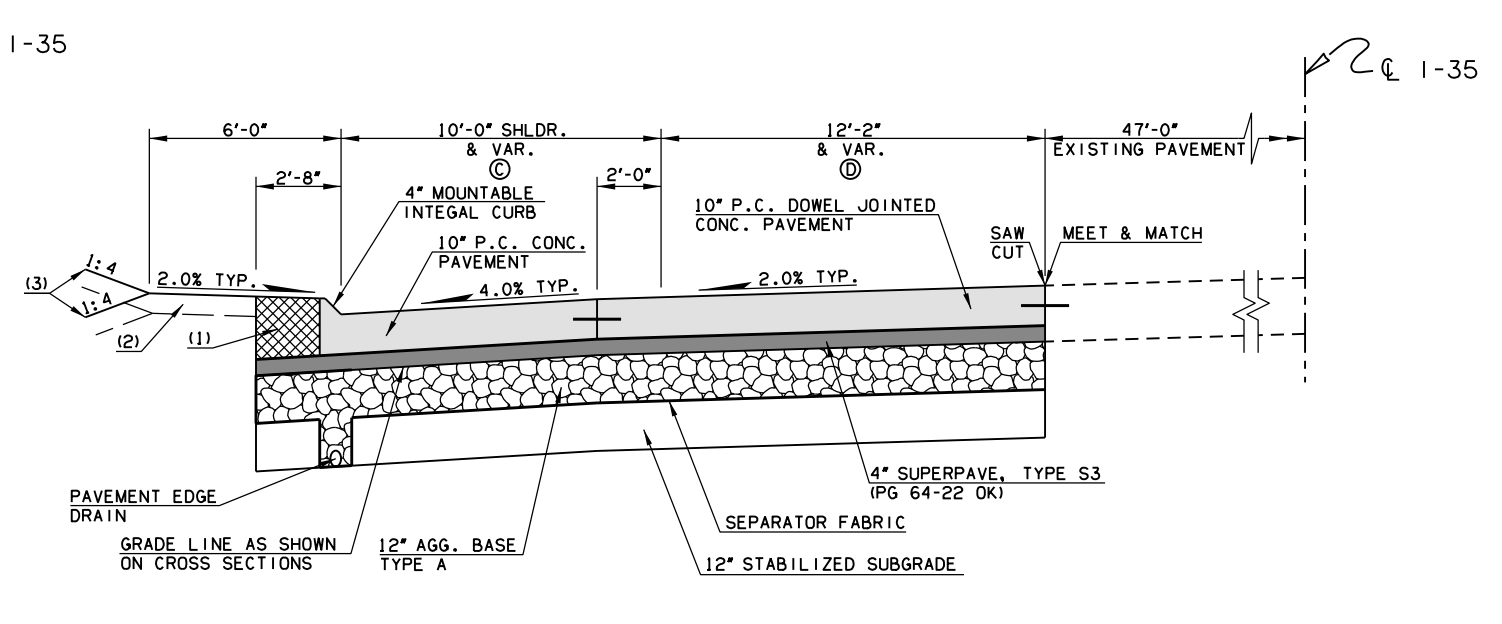

14 TYPICAL SECTION
I-35 WIDENING
STA. 87+83.85 TO STA. 95+64.51

SEGMENT	VARIABLE WIDTH	STATION EXTENTS
A	0'-0" TO 10'-0"	82+53.28 TO 82+93.82
B	0'-0" TO 12'-6"	82+93.82 TO 83+29.00
C	10'-0" TO 6'-0"	87+83.85 TO 90+63.80
C	6'-0"	90+63.80 TO 95+64.51
D	0'-0" TO 4'-0"	87+83.85 TO 90+63.80
D	4'-0" TO 11'-2"	90+63.80 TO 95+64.51

NOTE: VAR. NOT SHOWN SEE PLANS/DETAILS FOR MORE INFORMATION

(1) TO BE BACKFILLED AND COMPACTED AS PART OF FINISHING OPERATIONS. QUANTITY IS MEASURED IN UNCLASSIFIED BORROW.

(2) **TOPSOIL NOTE:**
THE CONTRACTOR SHALL STRIP ALL OF THE AVAILABLE TOPSOIL, STOCKPILE IT, AND PLACE IT BACK ON THE SECTION IN ACCORDANCE WITH SECTION 205 OF THE STANDARD SPECIFICATIONS. RESERVED TOPSOIL SHALL BE SPREAD FIRST ON THE COMPLETED SLOPES OF THE CUT SECTIONS AND THE REMAINDER ON COMPLETED FILL SLOPES OR OTHER PRIORITY AREAS LOCATED BY THE ENGINEER. ALL ADDITIONAL COSTS ASSOCIATED WITH OPERATION SHALL BE INCLUDED IN THE PAY ITEM FOR SALVAGED TOPSOIL, LUMP SUM.

(3) INTERSECTION OF CUT AND/OR FILL SLOPES WITH GROUND LINE TO BE ROUNDED AS PART OF FINISHING OPERATIONS. ROUNDED SHALL BE 5' MIN. FOR SMALLER CUTS AND FILLS, TO 15' MAX. FOR LARGER CUTS AND FILLS, OR AS DESIGNATED BY THE ENGINEER. COST OF ROUNDED TO BE INCLUDED IN PRICE BID FOR OTHER ITEMS OF WORK. SEE ROUNDED DETAIL ON OTHER TYPICAL SHEET.

(4) TO BE BACKFILLED AND COMPACTED AS PART OF FINISHING OPERATIONS. QUANTITY IS MEASURED IN T.B.S.C. TYPE E.

DESIGN	-	-	PHASE 4	OKLAHOMA COUNTY
DRAWN	-	-	TYPICAL SECTIONS (I-35 WIDENING)	
CHECKED	-	-		
APPROVED	-	-		
SQUAD	POE		STATE JOB NO. 09032108	SHEET NO. 0008

3/4/2024 2:33:57 PM H:\PROJECTS\2789_CrossRoads_Phase 4\Roadway\Drawings\0903208-Phase 4_TypSections.dgn

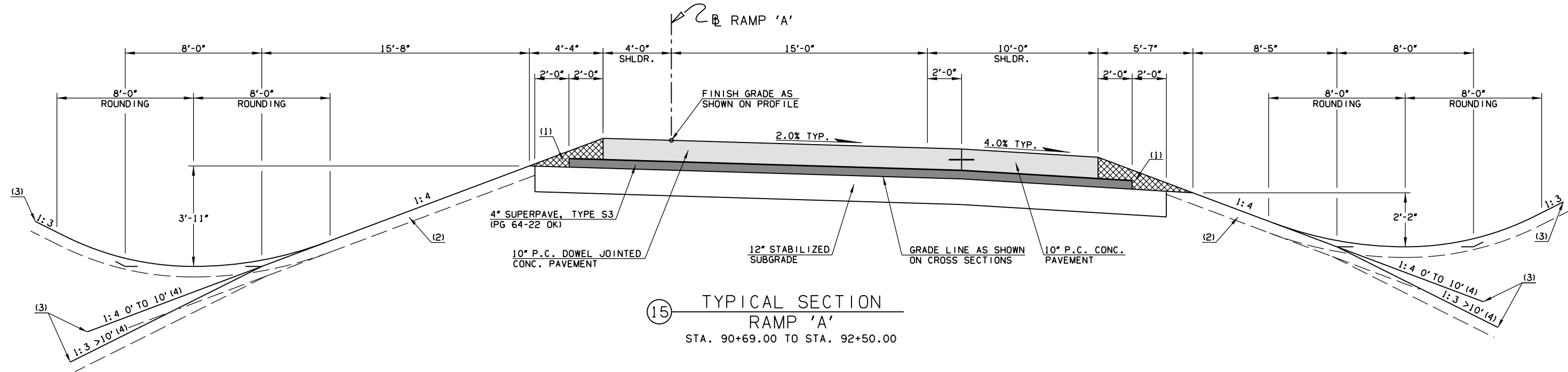

15 TYPICAL SECTION
RAMP 'A'
STA. 90+69.00 TO STA. 92+50.00

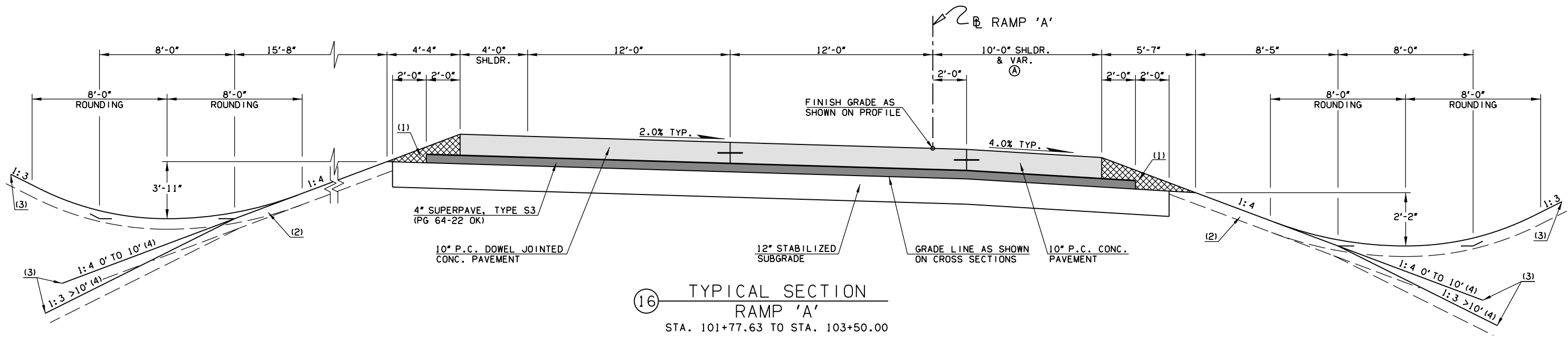

16 TYPICAL SECTION
RAMP 'A'
STA. 101+77.63 TO STA. 103+50.00

(1) TO BE BACKFILLED AND COMPACTED AS PART OF FINISHING OPERATIONS. QUANTITY IS MEASURED IN UNCLASSIFIED BORROW.

(2) TOPSOIL NOTE:

THE CONTRACTOR SHALL STRIP ALL OF THE AVAILABLE TOPSOIL, STOCKPILE IT, AND PLACE IT BACK ON THE SECTION IN ACCORDANCE WITH SECTION 205 OF THE STANDARD SPECIFICATIONS. RESERVED TOPSOIL SHALL BE SPREAD FIRST ON THE COMPLETED SLOPES OF THE CUT SECTIONS AND THE REMAINDER ON COMPLETED FILL SLOPES OR OTHER PRIORITY AREAS LOCATED BY THE ENGINEER. ALL ADDITIONAL COSTS ASSOCIATED WITH OPERATION SHALL BE INCLUDED IN THE PAY ITEM FOR SALVAGED TOPSOIL, LUMP SUM.

(3) INTERSECTION OF CUT AND/OR FILL SLOPES WITH GROUND LINE TO BE ROUNDED AS PART OF FINISHING OPERATIONS. ROUNDDING SHALL BE 5' MIN. FOR SMALLER CUTS AND FILLS, TO 15' MAX. FOR LARGER CUTS AND FILLS, OR AS DESIGNATED BY THE ENGINEER. COST OF ROUNDDING TO BE INCLUDED IN PRICE BID FOR OTHER ITEMS OF WORK. SEE ROUNDDING DETAIL ON OTHER TYPICAL SHEETS.

(4) TO BE BACKFILLED AND COMPACTED AS PART OF FINISHING OPERATIONS. QUANTITY IS MEASURED IN T.B.S.C. TYPE E.

SEGMENT	VARIABLE WIDTH	STATION EXTENTS
A	10'-0"	101+77.63 TO 102+70.00
A	10'-0" TO 12'-0"	102+70.00 TO 103+20.00
A	12'-0"	103+20.00 TO 103+50.00

NOTE: VAR. NOT SHOWN SEE PLANS/DETAILS FOR MORE INFORMATION

DESIGN	-	-	PHASE 4	OKLAHOMA COUNTY
DRAWN	-	-	TYPICAL SECTIONS (RAMP 'A')	
CHECKED	-	-		
APPROVED	-	-		
SQUAD	POE		STATE JOB NO. 09032108	SHEET NO. 0009

3/4/2024 2:33:58 PM H:\PROJECTS\2789_CrossRoads_Phase 4\Roadway\Drawings\0903208-Phase 4_TypSections.dgn

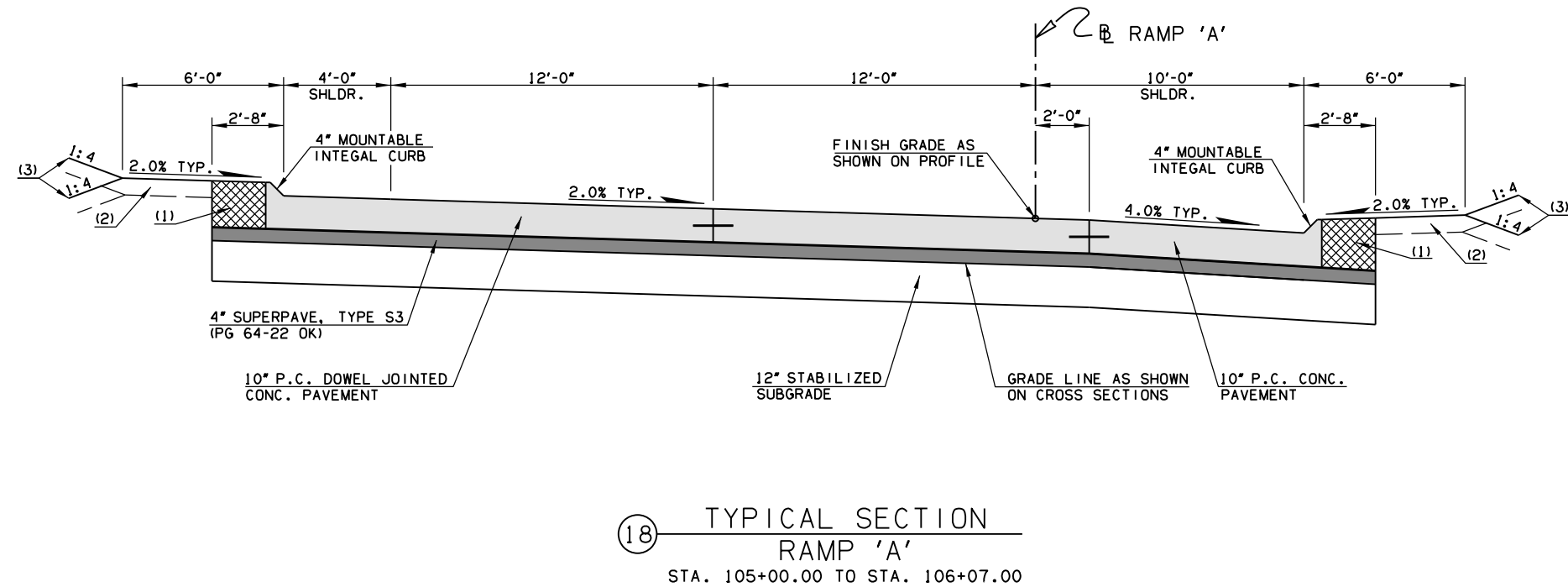
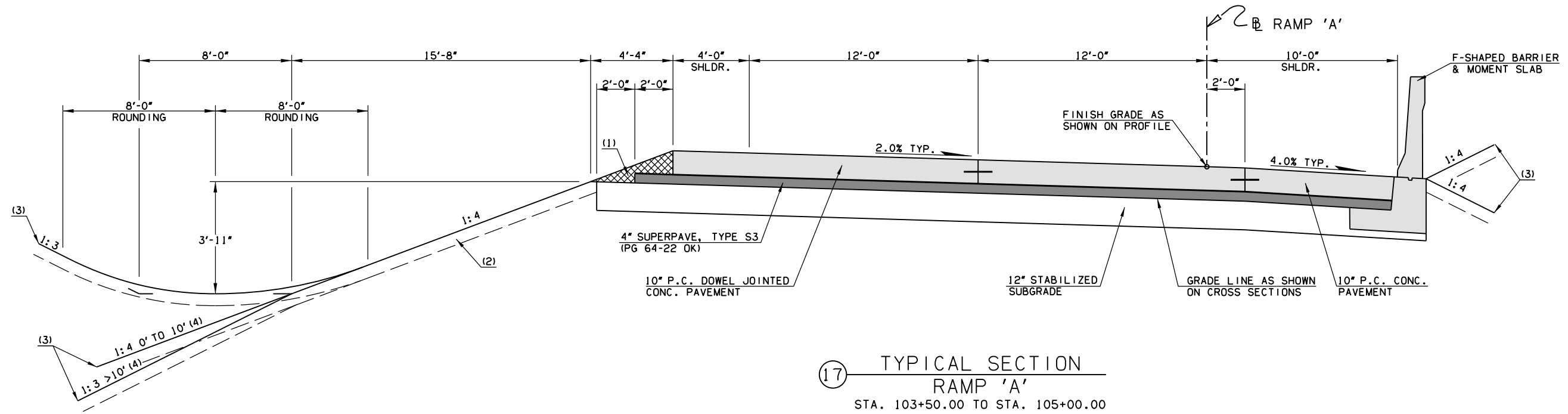

(1) TO BE BACKFILLED AND COMPACTED AS PART OF FINISHING OPERATIONS. QUANTITY IS MEASURED IN UNCLASSIFIED BORROW.

(2) TOPSOIL NOTE:

THE CONTRACTOR SHALL STRIP ALL OF THE AVAILABLE TOPSOIL, STOCKPILE IT, AND PLACE IT BACK ON THE SECTION IN ACCORDANCE WITH SECTION 205 OF THE STANDARD SPECIFICATIONS. RESERVED TOPSOIL SHALL BE SPREAD FIRST ON THE COMPLETED SLOPES OF THE CUT SECTIONS AND THE REMAINDER ON COMPLETED FILL SLOPES OR OTHER PRIORITY AREAS LOCATED BY THE ENGINEER. ALL ADDITIONAL COSTS ASSOCIATED WITH OPERATION SHALL BE INCLUDED IN THE PAY ITEM FOR SALVAGED TOPSOIL, LUMP SUM.

(3) INTERSECTION OF CUT AND/OR FILL SLOPES WITH GROUND LINE TO BE ROUNDED AS PART OF FINISHING OPERATIONS. ROUNDDING SHALL BE 5' MIN. FOR SMALLER CUTS AND FILLS, TO 15' MAX. FOR LARGER CUTS AND FILLS, OR AS DESIGNATED BY THE ENGINEER. COST OF ROUNDDING TO BE INCLUDED IN PRICE BID FOR OTHER ITEMS OF WORK. SEE ROUNDDING DETAIL ON OTHER TYPICAL SHEETS.

(4) TO BE BACKFILLED AND COMPACTED AS PART OF FINISHING OPERATIONS. QUANTITY IS MEASURED IN T.B.S.C. TYPE E.

DESIGN	-	-	PHASE 4	OKLAHOMA COUNTY
DRAWN	-	-	TYPICAL SECTIONS (RAMP 'A') STATE JOB NO. 09032108 SHEET NO. 0010	
CHECKED	-	-		
APPROVED	-	-		
SQUAD	POE			

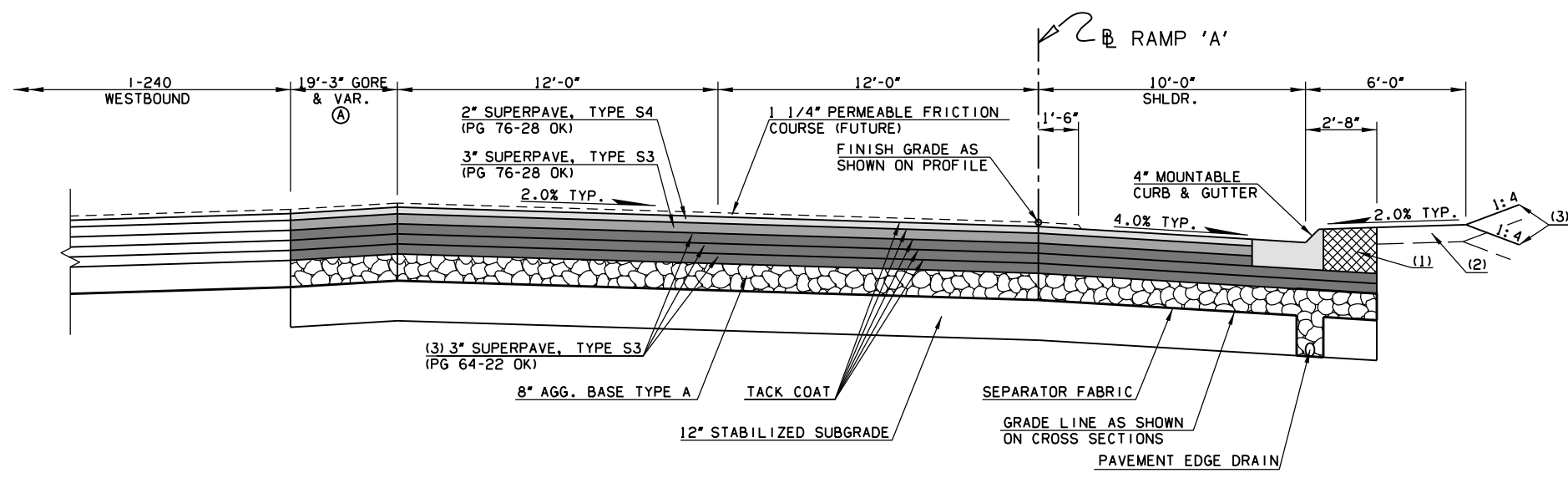

19 TYPICAL SECTION
RAMP 'A'
STA. 106+07.00 TO STA. 108+38.64

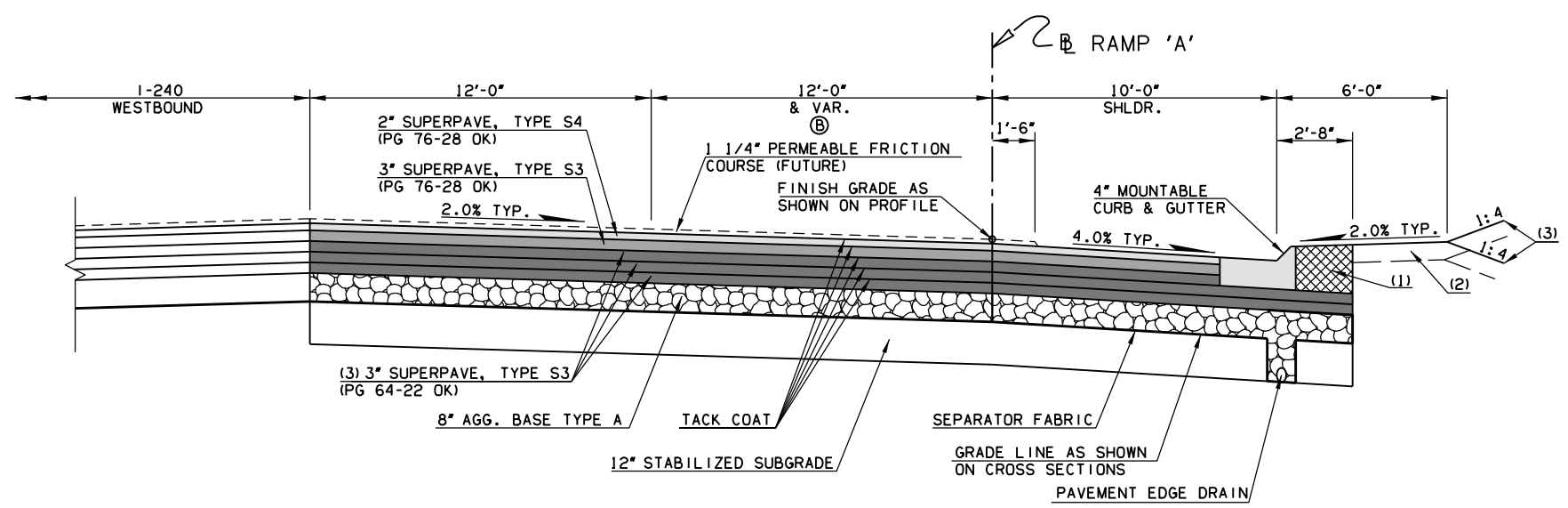

20 TYPICAL SECTION
RAMP 'A'
STA. 108+38.64 TO STA. 114+86.64

SEGMENT	VARIABLE WIDTH	STATION EXTENTS
A	19'-3" TO 0'-0"	106+07.00 TO 108+38.64
B	12'-0"	108+38.64 TO 111+86.64
B	12'-0" TO 0'-0"	111+86.64 TO 114+86.64

NOTE: VAR. NOT SHOWN SEE PLANS/DETAILS FOR MORE INFORMATION

(1) TO BE BACKFILLED AND COMPACTED AS PART OF FINISHING OPERATIONS. QUANTITY IS MEASURED IN UNCLASSIFIED BORROW.

(2) TOPSOIL NOTE:

THE CONTRACTOR SHALL STRIP ALL OF THE AVAILABLE TOPSOIL, STOCKPILE IT, AND PLACE IT BACK ON THE SECTION IN ACCORDANCE WITH SECTION 205 OF THE STANDARD SPECIFICATIONS. RESERVED TOPSOIL SHALL BE SPREAD FIRST ON THE COMPLETED SLOPES OF THE CUT SECTIONS AND THE REMAINDER ON COMPLETED FILL SLOPES OR OTHER PRIORITY AREAS LOCATED BY THE ENGINEER. ALL ADDITIONAL COSTS ASSOCIATED WITH OPERATION SHALL BE INCLUDED IN THE PAY ITEM FOR SALVAGED TOPSOIL, LUMP SUM.

(3) INTERSECTION OF CUT AND/OR FILL SLOPES WITH GROUND LINE TO BE ROUNDED AS PART OF FINISHING OPERATIONS. ROUNDED SHALL BE 5' MIN. FOR SMALLER CUTS AND FILLS, TO 15' MAX. FOR LARGER CUTS AND FILLS, OR AS DESIGNATED BY THE ENGINEER. COST OF ROUNDED TO BE INCLUDED IN PRICE BID FOR OTHER ITEMS OF WORK. SEE ROUNDED DETAIL ON OTHER TYPICAL SHEETS.

(4) TO BE BACKFILLED AND COMPACTED AS PART OF FINISHING OPERATIONS. QUANTITY IS MEASURED IN T.B.S.C. TYPE E.

DESIGN	-	-	PHASE 4	OKLAHOMA COUNTY
DRAWN	-	-	TYPICAL SECTIONS (RAMP 'A')	
CHECKED	-	-		
APPROVED	-	-		
SQUAD	POE		STATE JOB NO. 09032108	SHEET NO. 0011

3/4/2024 2:33:59 PM H:\PROJECTS\2785_CrossRoads_Phase 4\Roadway\Drawings\0903208-Phase 4_TypSections.dgn

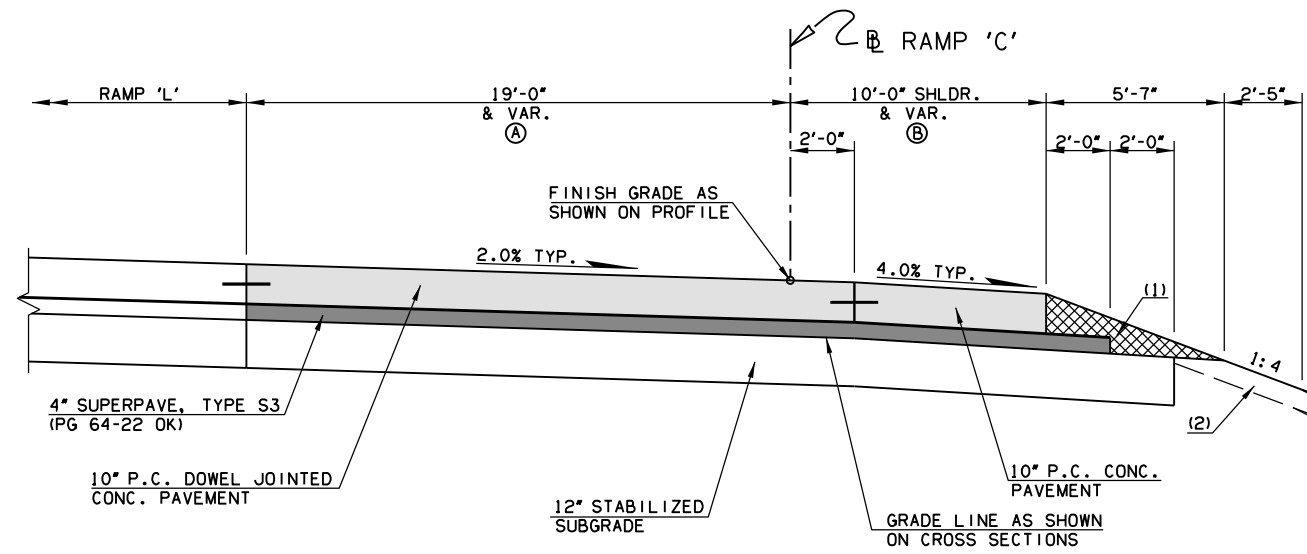

(21) **TYPICAL SECTION
RAMP 'C'**
STA. 71+30.93 TO STA. 72+21.36

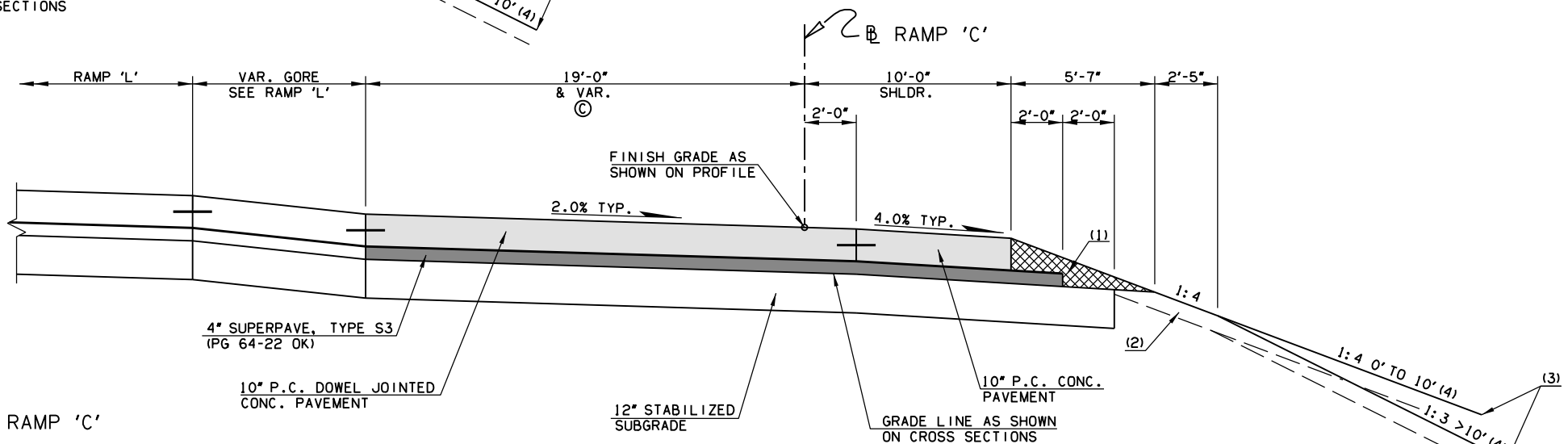

(22) **TYPICAL SECTION
RAMP 'C'**
STA. 72+21.36 TO STA. 72+64.85

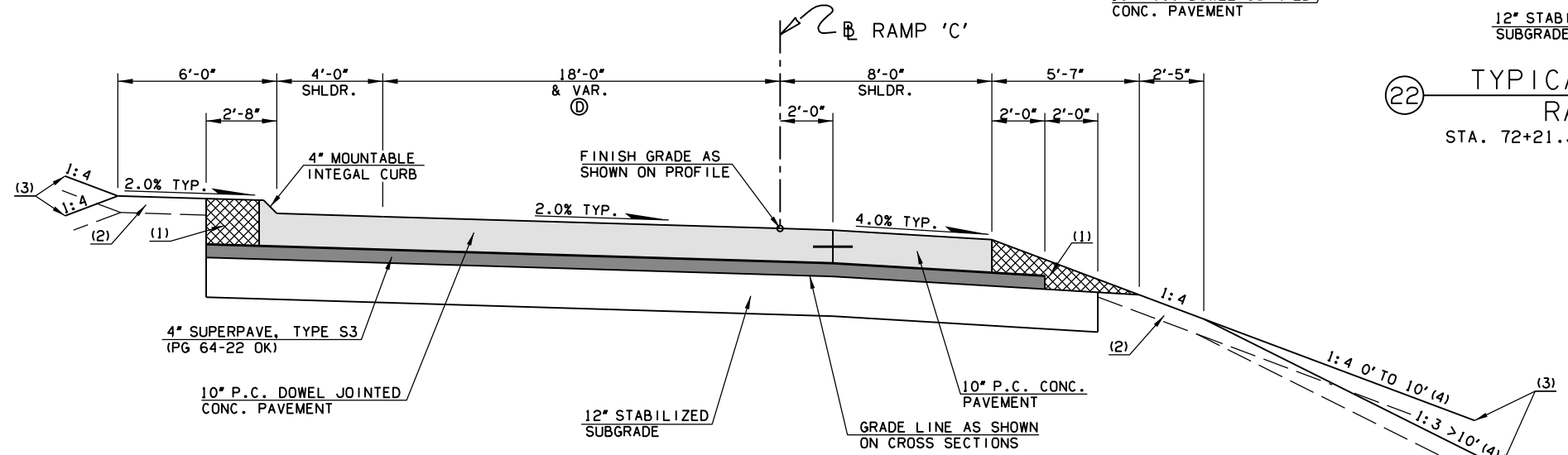

(23) **TYPICAL SECTION
RAMP 'C'**
STA. 72+64.85 TO STA. 81+08.03

(1) TO BE BACKFILLED AND COMPACTED AS PART OF FINISHING OPERATIONS. QUANTITY IS MEASURED IN UNCLASSIFIED BORROW.

(2) **TOPSOIL NOTE:**
THE CONTRACTOR SHALL STRIP ALL OF THE AVAILABLE TOPSOIL, STOCKPILE IT, AND PLACE IT BACK ON THE SECTION IN ACCORDANCE WITH SECTION 205 OF THE STANDARD SPECIFICATIONS. RESERVED TOPSOIL SHALL BE SPREAD FIRST ON THE COMPLETED SLOPES OF THE CUT SECTIONS AND THE REMAINDER ON COMPLETED FILL SLOPES OR OTHER PRIORITY AREAS LOCATED BY THE ENGINEER. ALL ADDITIONAL COSTS ASSOCIATED WITH OPERATION SHALL BE INCLUDED IN THE PAY ITEM FOR SALVAGED TOPSOIL, LUMP SUM.

(3) INTERSECTION OF CUT AND/OR FILL SLOPES WITH GROUND LINE TO BE ROUNDED AS PART OF FINISHING OPERATIONS. ROUNDED SHALL BE 5' MIN. FOR SMALLER CUTS AND FILLS, TO 15' MAX. FOR LARGER CUTS AND FILLS, OR AS DESIGNATED BY THE ENGINEER. COST OF ROUNDED TO BE INCLUDED IN PRICE BID FOR OTHER ITEMS OF WORK. SEE ROUNDED DETAIL ON OTHER TYPICAL SHEETS.

(4) TO BE BACKFILLED AND COMPACTED AS PART OF FINISHING OPERATIONS. QUANTITY IS MEASURED IN T.B.S.C. TYPE E.

SEGMENT	VARIABLE WIDTH	STATION EXTENTS
A	0'-0" TO 19'-0"	71+30.93 TO 72+21.36
B	10'-0" TO 8'-0"	71+30.93 TO 71+61.83
B	8'-0"	71+61.83 TO 72+21.36
C	19'-0" TO 18'-0"	72+21.36 TO 72+64.85
D	18'-0" TO 15'-0"	72+64.85 TO 73+10.69
D	15'-0"	73+10.69 TO 81+08.03

NOTE: VAR. NOT SHOWN SEE PLANS/DETAILS FOR MORE INFORMATION

DESIGN	-	-	PHASE 4	OKLAHOMA COUNTY
DRAWN	-	-	TYPICAL SECTIONS (RAMP 'C') STATE JOB NO. 09032108 SHEET NO. 0012	
CHECKED	-	-		
APPROVED	-	-		
SQUAD	POE			

3/4/2024 2:33:59 PM H:\PROJECTS\2789_CrossRoads_Phase 4\Roadway\Drawings\0903208-Phase 4_TypSections.dgn

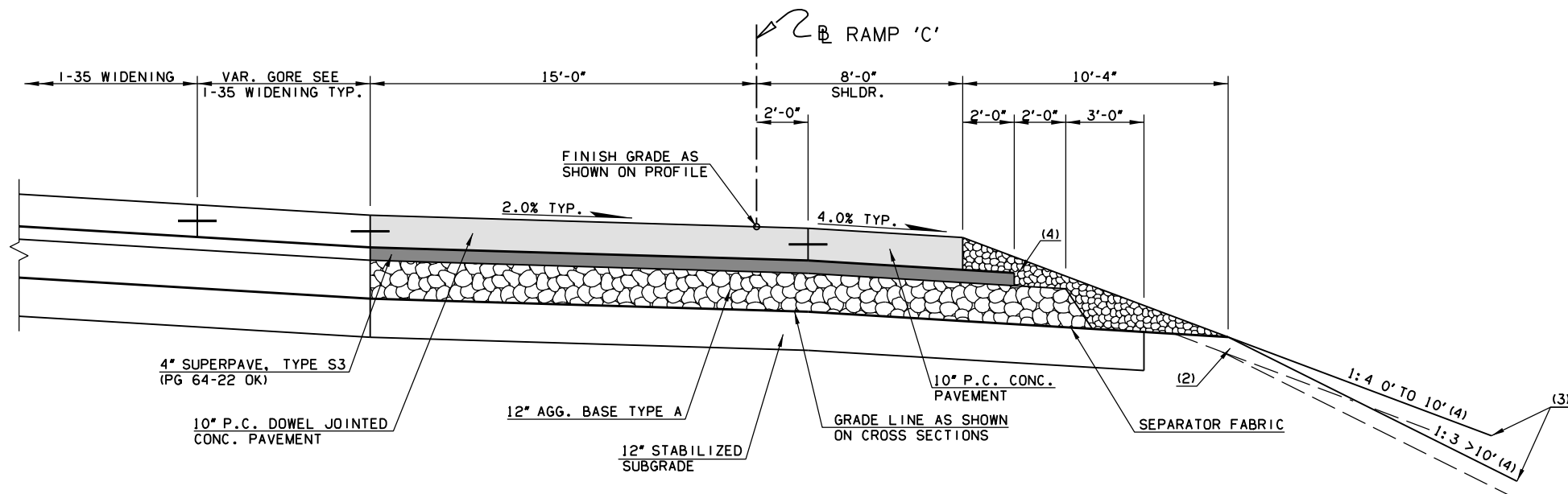

24 TYPICAL SECTION
RAMP 'C'
STA. 81+08.03 TO STA. 81+79.00

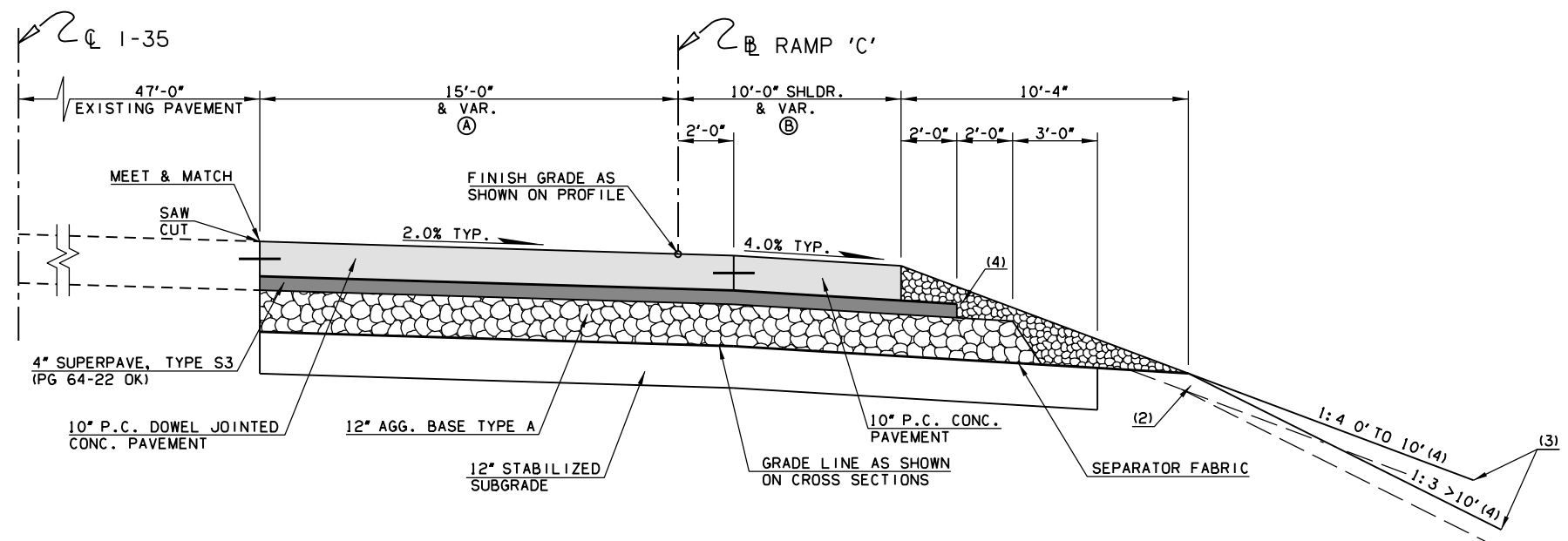

25 TYPICAL SECTION
RAMP 'C'
STA. 81+79.00 TO STA. 83+21.00

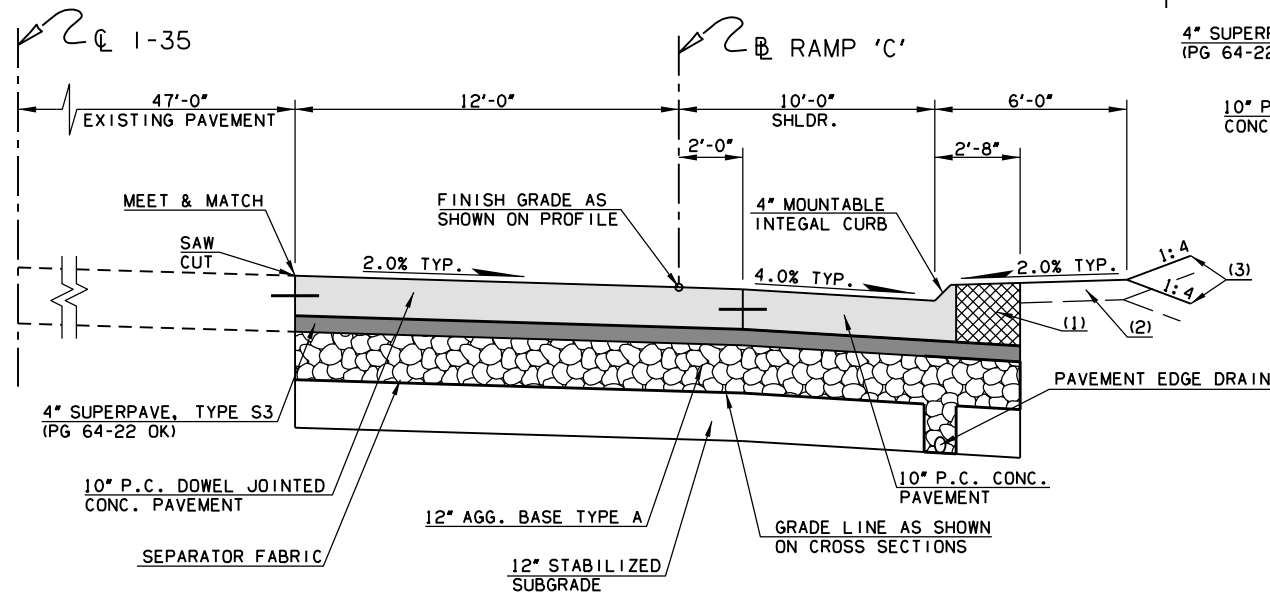

26 TYPICAL SECTION
RAMP 'C'
STA. 83+21.00 TO STA. 88+89.63

SEGMENT	VARIABLE WIDTH	STATION EXTENTS
A	15'-0" TO 12'-0"	81+79.00 TO 82+15.04
A	12'-0"	82+15.04 TO 83+21.00
B	8'-0"	81+79.00 TO 81+83.68
B	8'-0" TO 10'-0"	81+83.68 TO 82+15.00
B	10'-0"	82+15.00 TO 83+21.00

NOTE: VAR. NOT SHOWN SEE PLANS/DETAILS FOR MORE INFORMATION

(1) TO BE BACKFILLED AND COMPACTED AS PART OF FINISHING OPERATIONS. QUANTITY IS MEASURED IN UNCLASSIFIED BORROW.

(2) TOPSOIL NOTE:

THE CONTRACTOR SHALL STRIP ALL OF THE AVAILABLE TOPSOIL, STOCKPILE IT, AND PLACE IT BACK ON THE SECTION IN ACCORDANCE WITH SECTION 205 OF THE STANDARD SPECIFICATIONS. RESERVED TOPSOIL SHALL BE SPREAD FIRST ON THE COMPLETED SLOPES OF THE CUT SECTIONS AND THE REMAINDER ON COMPLETED FILL SLOPES OR OTHER PRIORITY AREAS LOCATED BY THE ENGINEER. ALL ADDITIONAL COSTS ASSOCIATED WITH OPERATION SHALL BE INCLUDED IN THE PAY ITEM FOR SALVAGED TOPSOIL, LUMP SUM.

(3) INTERSECTION OF CUT AND/OR FILL SLOPES WITH GROUND LINE TO BE ROUNDED AS PART OF FINISHING OPERATIONS. ROUNDED SHALL BE 5' MIN. FOR SMALLER CUTS AND FILLS, TO 15' MAX. FOR LARGER CUTS AND FILLS, OR AS DESIGNATED BY THE ENGINEER. COST OF ROUNDED TO BE INCLUDED IN PRICE BID FOR OTHER ITEMS OF WORK. SEE ROUNDED DETAIL ON OTHER TYPICAL SHEETS.

(4) TO BE BACKFILLED AND COMPACTED AS PART OF FINISHING OPERATIONS. QUANTITY IS MEASURED IN T.B.S.C. TYPE E.

DESIGN	-	-	PHASE 4	OKLAHOMA COUNTY
DRAWN	-	-	TYPICAL SECTIONS (RAMP 'C')	
CHECKED	-	-		
APPROVED	-	-		
SQUAD	POE		STATE JOB NO. 09032108	SHEET NO. 0013

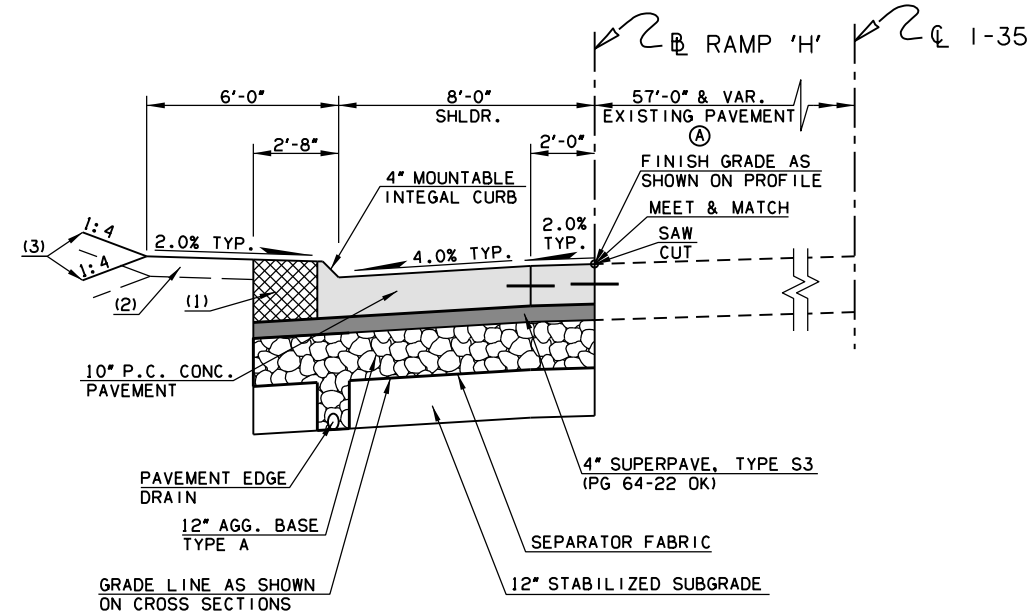

27 TYPICAL SECTION
RAMP 'H'
STA. 414+32.34 TO STA. 421+17.04

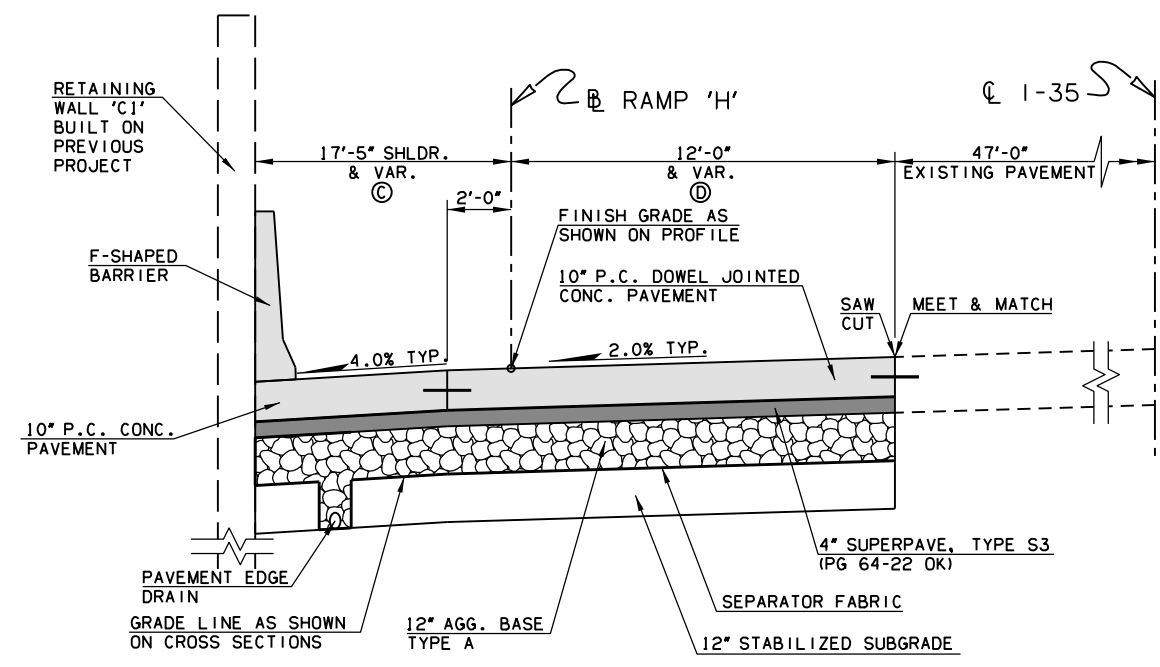

29 TYPICAL SECTION
RAMP 'H'
STA. 421+71.30 TO STA. 424+09.03

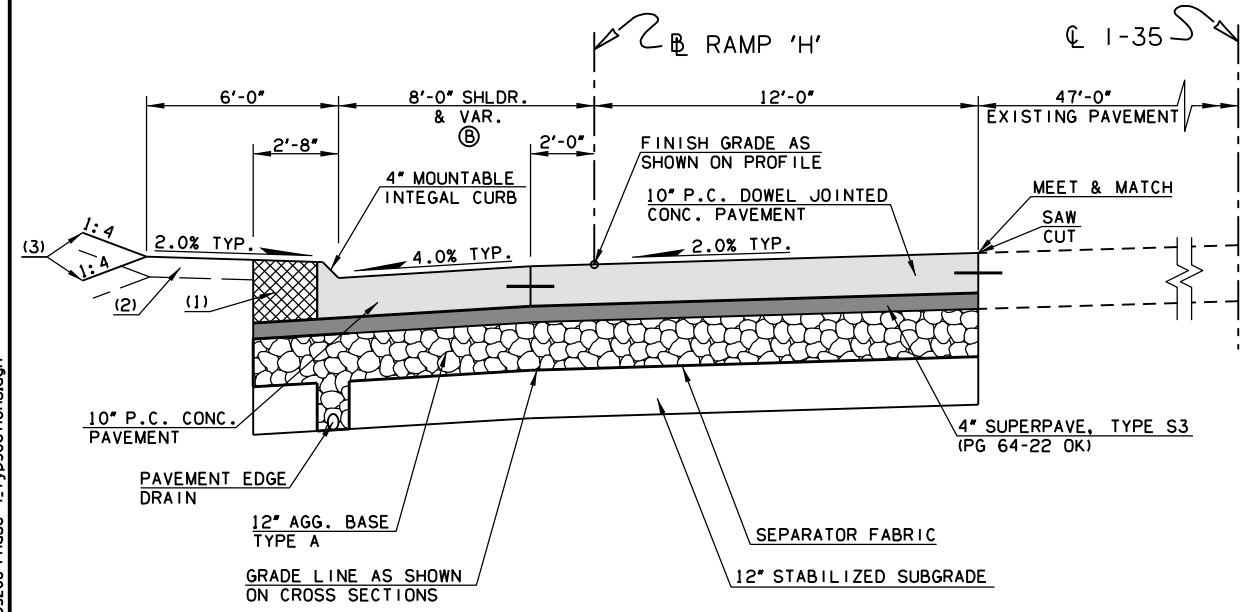

28 TYPICAL SECTION
RAMP 'H'
STA. 421+17.04 TO STA. 421+71.30

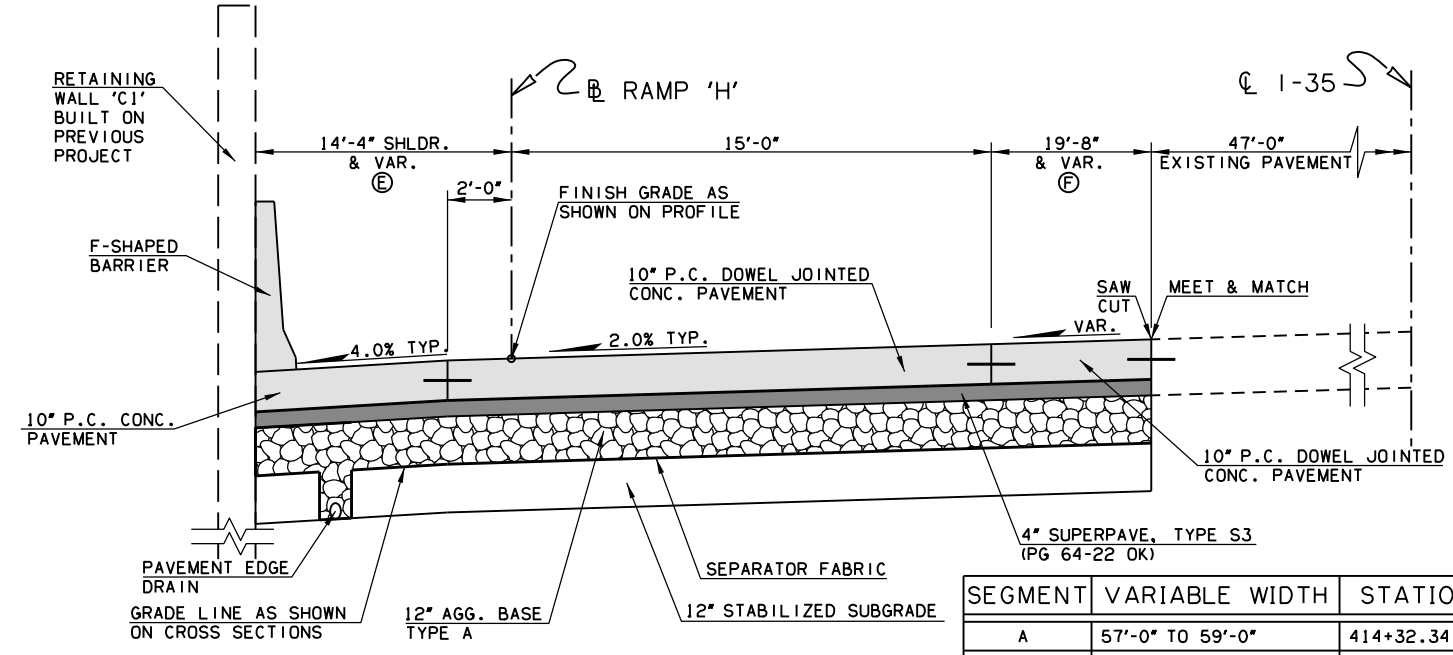

30 TYPICAL SECTION
RAMP 'H'
STA. 424+09.03 TO STA. 425+40.19

SEGMENT	VARIABLE WIDTH	STATION EXTENTS
A	57'-0" TO 59'-0"	414+32.34 TO 415+72.34
A	59'-0"	415+72.34 TO 421+17.04
B	8'-0" TO 16'-2"	421+17.04 TO 421+66.23
B	16'-2"	421+66.23 TO 421+71.30
C	17'-5" TO 14'-5"	421+71.30 TO 424+09.03
D	12'-0"	421+71.30 TO 423+33.91
D	12'-0" TO 15'-0"	423+33.91 TO 424+09.03
E	14'-5" TO 16'-4"	424+09.03 TO 425+40.19
F	0'-0" TO 19'-8"	424+09.03 TO 425+38.50
F	19'-8" TO 9'-10"	425+38.50 TO 425+40.19

NOTE: VAR. NOT SHOWN SEE PLANS/DETAILS FOR MORE INFORMATION

- (1) TO BE BACKFILLED AND COMPACTED AS PART OF FINISHING OPERATIONS. QUANTITY IS MEASURED IN UNCLASSIFIED BORROW.
- (2) **TOPSOIL NOTE:**
THE CONTRACTOR SHALL STRIP ALL OF THE AVAILABLE TOPSOIL, STOCKPILE IT, AND PLACE IT BACK ON THE SECTION IN ACCORDANCE WITH SECTION 205 OF THE STANDARD SPECIFICATIONS. RESERVED TOPSOIL SHALL BE SPREAD FIRST ON THE COMPLETED SLOPES OF THE CUT SECTIONS AND THE REMAINDER ON COMPLETED FILL SLOPES OR OTHER PRIORITY AREAS LOCATED BY THE ENGINEER. ALL ADDITIONAL COSTS ASSOCIATED WITH OPERATION SHALL BE INCLUDED IN THE PAY ITEM FOR SALVAGED TOPSOIL, LUMP SUM.
- (3) INTERSECTION OF CUT AND/OR FILL SLOPES WITH GROUND LINE TO BE ROUNDED AS PART OF FINISHING OPERATIONS. ROUNDED SHALL BE 5' MIN. FOR SMALLER CUTS AND FILLS, TO 15' MAX. FOR LARGER CUTS AND FILLS, OR AS DESIGNATED BY THE ENGINEER. COST OF ROUNDED TO BE INCLUDED IN PRICE BID FOR OTHER ITEMS OF WORK. SEE ROUNDED DETAIL ON OTHER TYPICAL SHEETS.
- (4) TO BE BACKFILLED AND COMPACTED AS PART OF FINISHING OPERATIONS. QUANTITY IS MEASURED IN T.B.S.C. TYPE E.

DESIGN	-	-	PHASE 4	OKLAHOMA COUNTY
DRAWN	-	-	TYPICAL SECTIONS (RAMP 'H')	
CHECKED	-	-		
APPROVED	-	-		
SQUAD	POE			
			STATE JOB NO. 09032108	SHEET NO. 0014

3/4/2024 2:34:00 PM H:\PROJECTS\2789_CrossRoads_Phase 4\Roadway\Drawings\0903208-Phase 4_TypSections.dgn

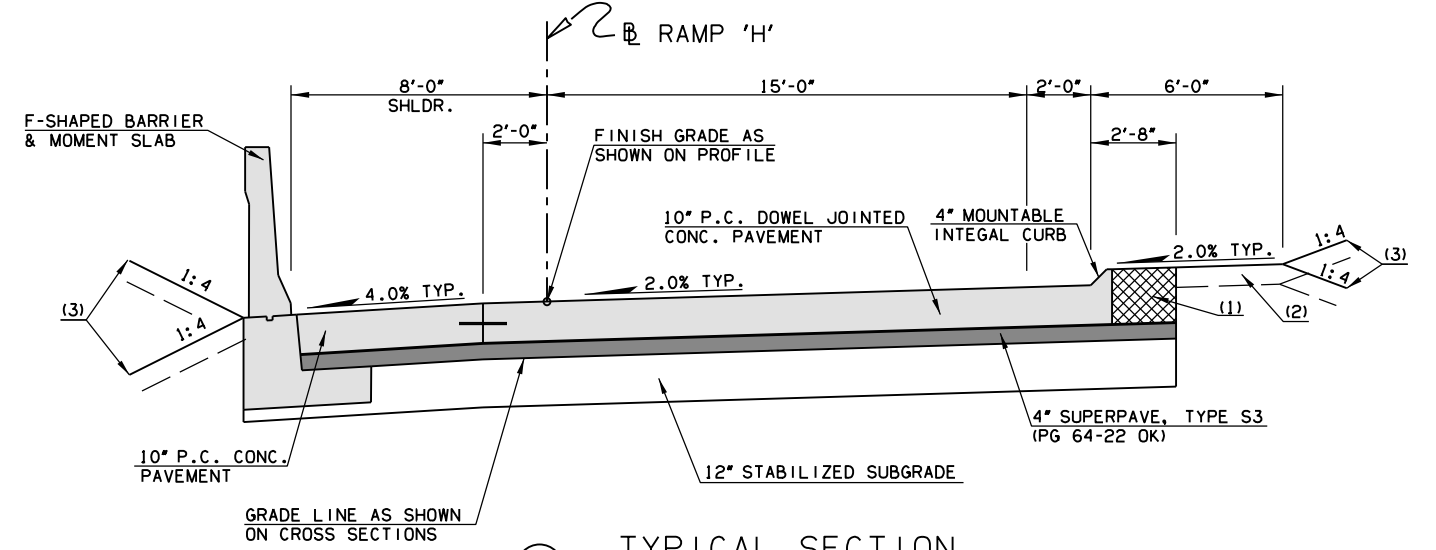
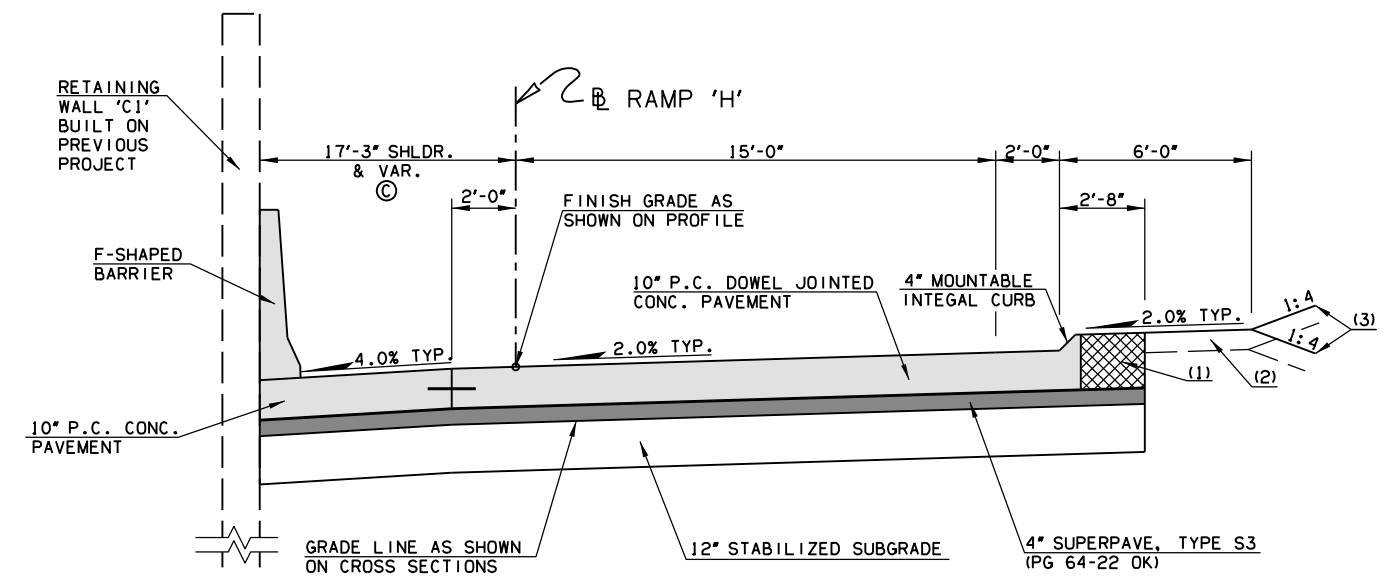
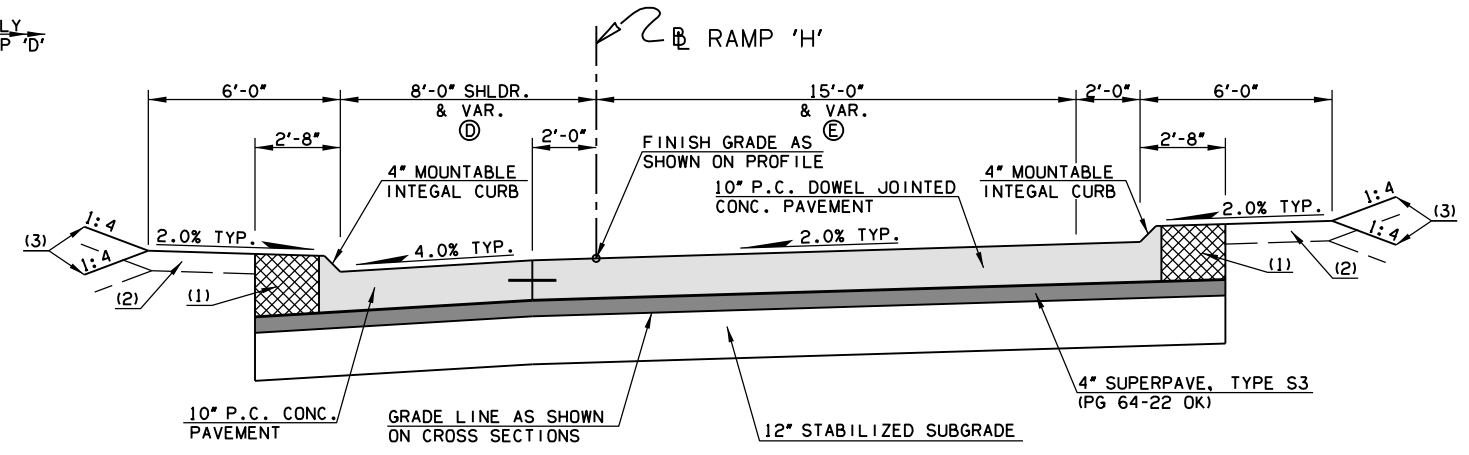
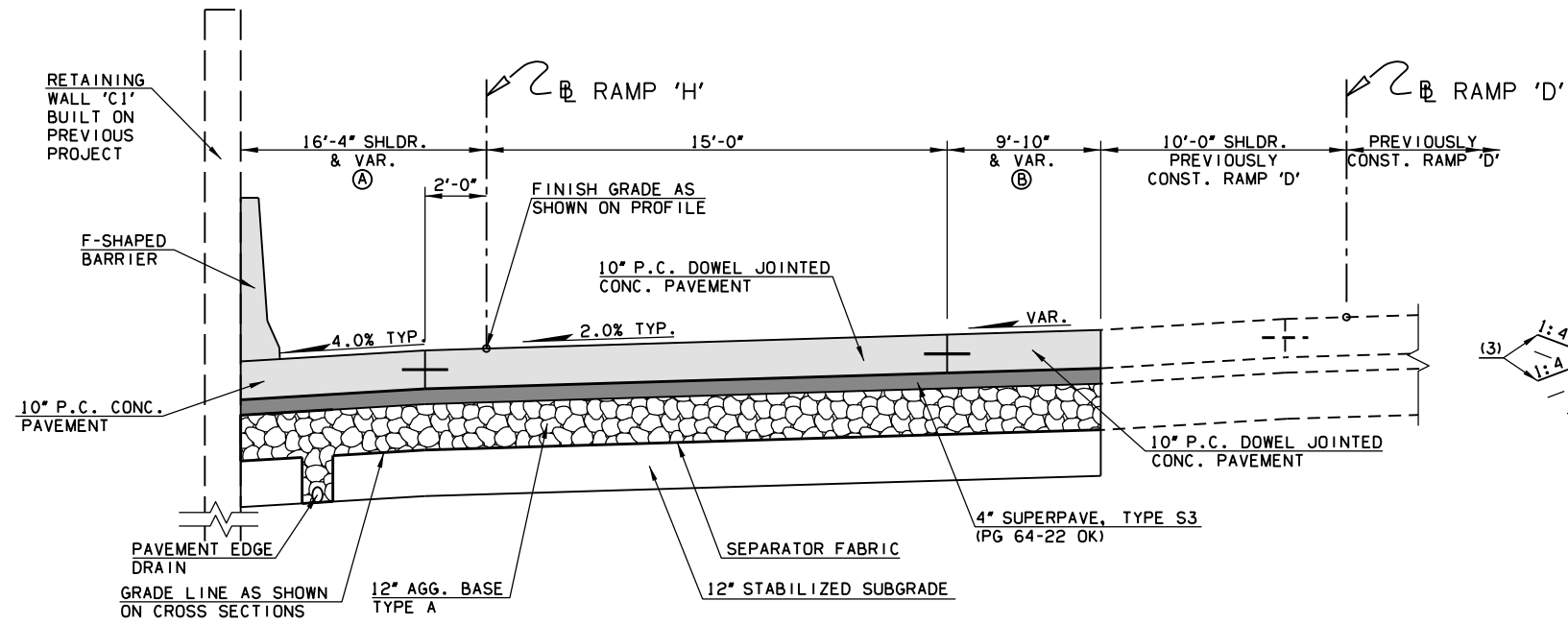

SEGMENT	VARIABLE WIDTH	STATION EXTENTS
A	16'-4" TO 17'-3"	425+40.19 TO 425+52.39
B	9'-10" TO 12'-0"	425+40.19 TO 425+52.39
C	17'-3" TO 21'-7"	425+52.39 TO 426+00.00
D	8'-0"	426+00.00 TO 433+00.00
D	10'-0"	434+32.00 TO 435+13.00
E	15'-0"	426+00.00 TO 433+00.00
E	15'-0"	434+32.00 TO 434+85.71
E	15'-0" TO 16'-6"	434+85.71 TO 435+13.00

NOTE: VAR. NOT SHOWN SEE PLANS/DETAILS FOR MORE INFORMATION

- (1) TO BE BACKFILLED AND COMPACTED AS PART OF FINISHING OPERATIONS. QUANTITY IS MEASURED IN UNCLASSIFIED BORROW.
- (2) **TOPSOIL NOTE:**
THE CONTRACTOR SHALL STRIP ALL OF THE AVAILABLE TOPSOIL, STOCKPILE IT, AND PLACE IT BACK ON THE SECTION IN ACCORDANCE WITH SECTION 205 OF THE STANDARD SPECIFICATIONS. RESERVED TOPSOIL SHALL BE SPREAD FIRST ON THE COMPLETED SLOPES OF THE CUT SECTIONS AND THE REMAINDER ON COMPLETED FILL SLOPES OR OTHER PRIORITY AREAS LOCATED BY THE ENGINEER. ALL ADDITIONAL COSTS ASSOCIATED WITH OPERATION SHALL BE INCLUDED IN THE PAY ITEM FOR SALVAGED TOPSOIL, LUMP SUM.
- (3) INTERSECTION OF CUT AND/OR FILL SLOPES WITH GROUND LINE TO BE ROUNDED AS PART OF FINISHING OPERATIONS. ROUNDED SHALL BE 5' MIN. FOR SMALLER CUTS AND FILLS, TO 15' MAX. FOR LARGER CUTS AND FILLS, OR AS DESIGNATED BY THE ENGINEER. COST OF ROUNDED TO BE INCLUDED IN PRICE BID FOR OTHER ITEMS OF WORK. SEE ROUNDED DETAIL ON OTHER TYPICAL SHEETS.
- (4) TO BE BACKFILLED AND COMPACTED AS PART OF FINISHING OPERATIONS. QUANTITY IS MEASURED IN T.B.S.C. TYPE E.

DESIGN	-	-	PHASE 4	OKLAHOMA COUNTY
DRAWN	-	-	TYPICAL SECTIONS (RAMP 'H')	
CHECKED	-	-		
APPROVED	-	-		
SQUAD	POE		STATE JOB NO. 09032108	SHEET NO. 0015

3/4/2024 2:34:01 PM H:\PROJECTS\2789_CrossRoads_Phase 4\Roadway\Drawings\0903208-Phase 4_TypSections.dgn

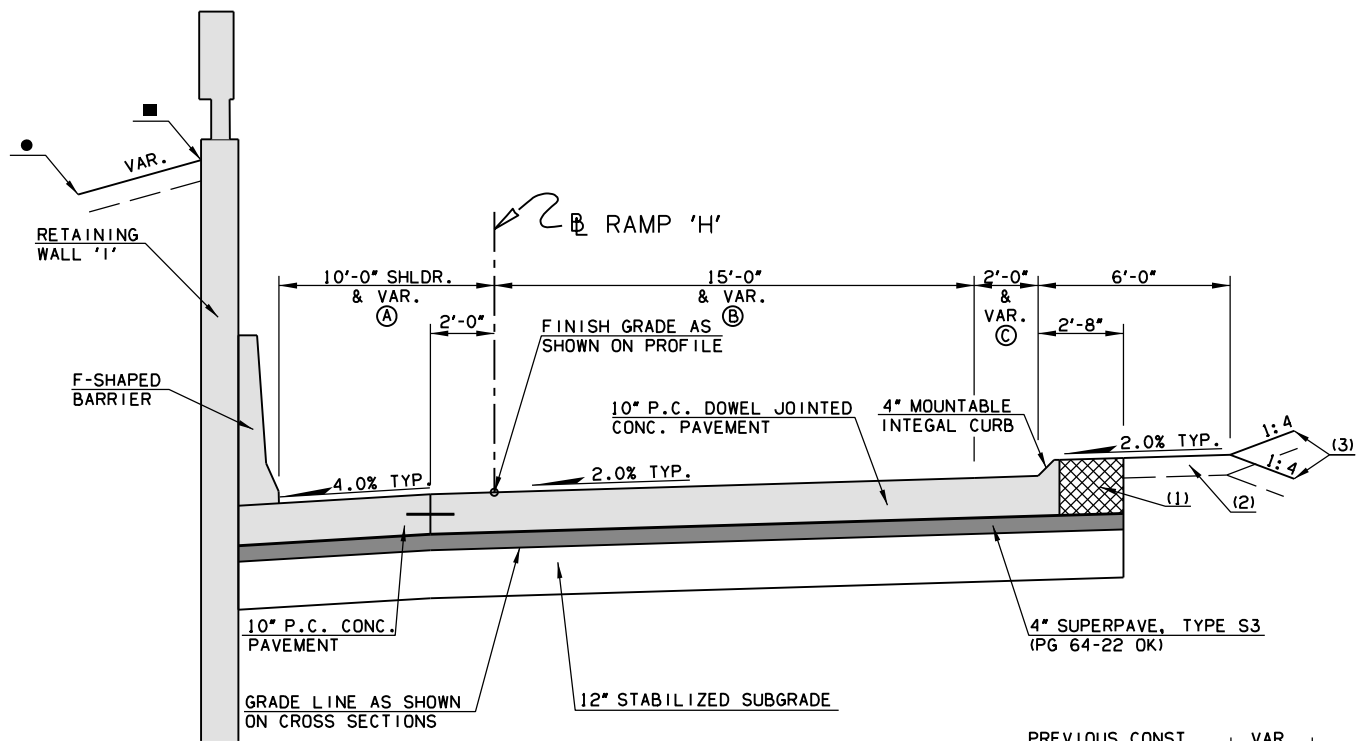

35 TYPICAL SECTION
RAMP 'H'

STA. 435+13.00 TO STA. 435+60.83
STA. 438+35.00 TO STA. 439+15.07

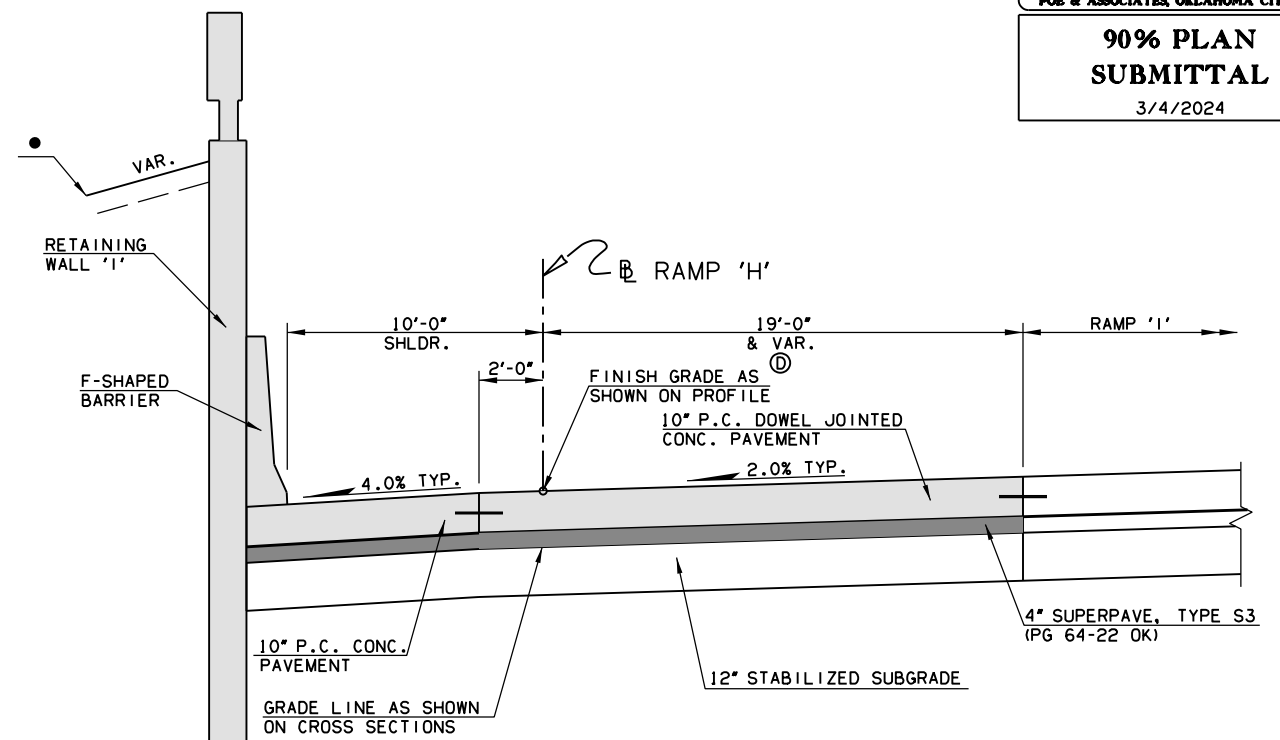

37 TYPICAL SECTION
RAMP 'H'

STA. 436+46.07 TO STA. 438+35.00

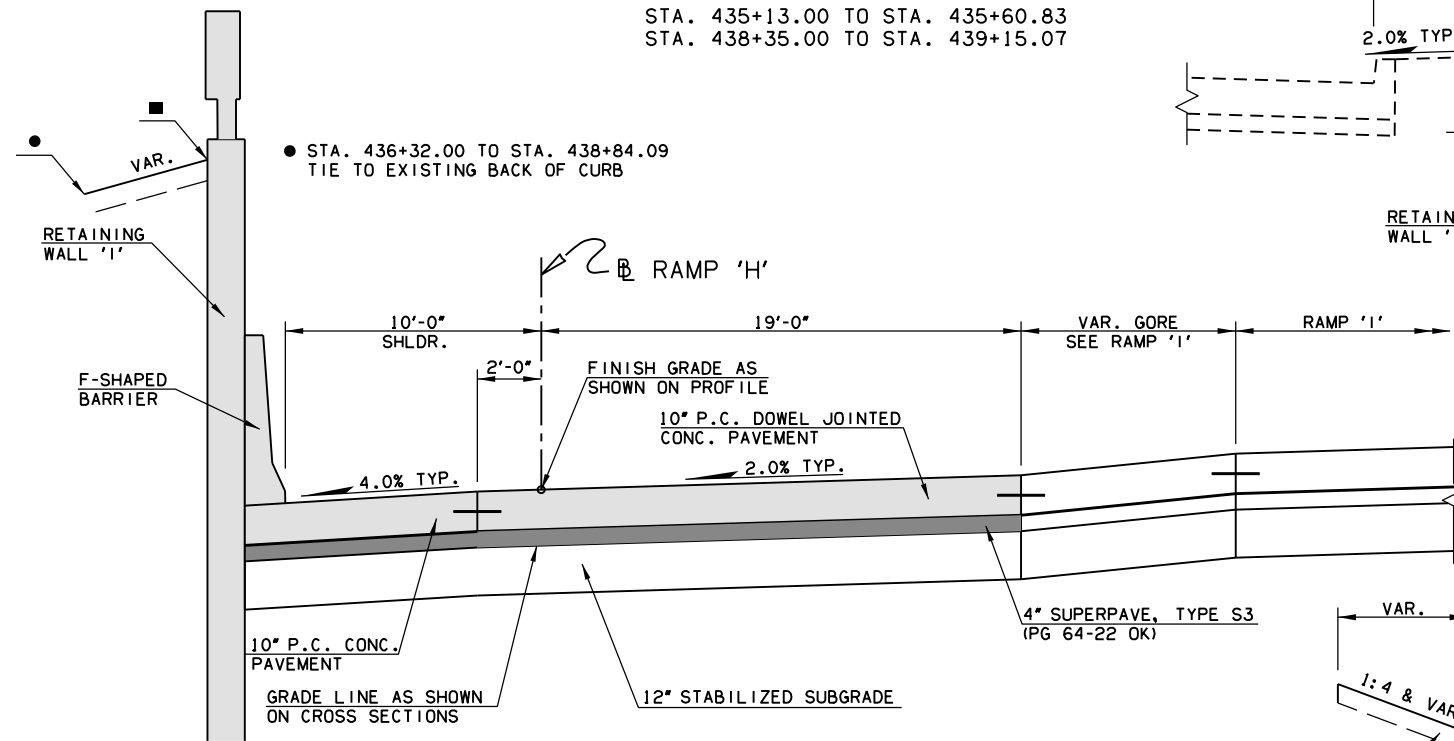

36 TYPICAL SECTION
RAMP 'H'

STA. 435+60.83 TO STA. 436+46.07

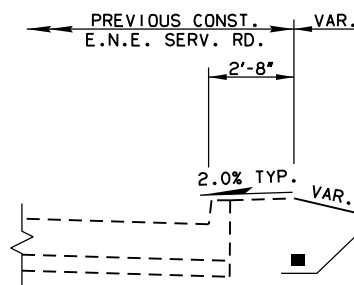

PAVED DITCH
LOCATIONS

STA. 435+13.00 TO STA. 436+32.00
STA. 438+84.09 TO STA. 439+59.00

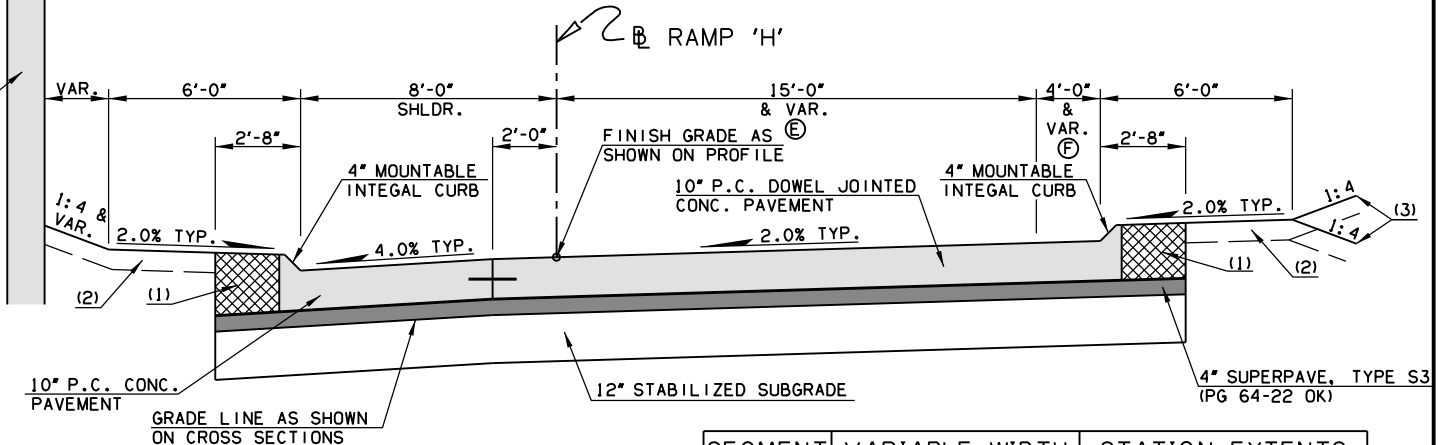

38 TYPICAL SECTION
RAMP 'H'

STA. 439+15.07 TO STA. 443+42.15

SEGMENT	VARIABLE WIDTH	STATION EXTENTS
A	10'-0"	435+13.00 TO 435+60.83
A	10'-0" TO 18'-9"	438+35.00 TO 439+15.07
B	16'-6" TO 19'-0"	435+13.00 TO 435+60.83
B	15'-0"	438+35.00 TO 439+15.07
C	2'-0"	435+13.00 TO 435+60.83
C	4'-0"	438+35.00 TO 439+15.07
D	19'-0" TO 0'-0"	436+46.07 TO 438+35.00
E	15'-0"	439+59.10 TO 443+27.51
E	15'-0" TO 15'-7"	443+27.51 TO 443+42.15
F	4'-0"	439+15.07 TO 443+27.51
F	4'-0" TO 4'-6"	443+27.51 TO 443+42.15

NOTE: VAR. NOT SHOWN SEE PLANS/DETAILS FOR MORE INFORMATION

(1) TO BE BACKFILLED AND COMPACTED AS PART OF FINISHING OPERATIONS. QUANTITY IS MEASURED IN UNCLASSIFIED BORROW.

(2) TOPSOIL NOTE:

THE CONTRACTOR SHALL STRIP ALL OF THE AVAILABLE TOPSOIL, STOCKPILE IT, AND PLACE IT BACK ON THE SECTION IN ACCORDANCE WITH SECTION 205 OF THE STANDARD SPECIFICATIONS. RESERVED TOPSOIL SHALL BE SPREAD FIRST ON THE COMPLETED SLOPES OF THE CUT SECTIONS AND THE REMAINDER ON COMPLETED FILL SLOPES OR OTHER PRIORITY AREAS LOCATED BY THE ENGINEER. ALL ADDITIONAL COSTS ASSOCIATED WITH OPERATION SHALL BE INCLUDED IN THE PAY ITEM FOR SALVAGED TOPSOIL, LUMP SUM.

(3) INTERSECTION OF CUT AND/OR FILL SLOPES WITH GROUND LINE TO BE ROUNDED AS PART OF FINISHING OPERATIONS. ROUNDED SHALL BE 5' MIN. FOR SMALLER CUTS AND FILLS, TO 15' MAX. FOR LARGER CUTS AND FILLS, OR AS DESIGNATED BY THE ENGINEER. COST OF ROUNDED TO BE INCLUDED IN PRICE BID FOR OTHER ITEMS OF WORK. SEE ROUNDED DETAIL ON OTHER TYPICAL SHEETS.

(4) TO BE BACKFILLED AND COMPACTED AS PART OF FINISHING OPERATIONS. QUANTITY IS MEASURED IN T.B.S.C. TYPE E.

DESIGN	-	-	PHASE 4	OKLAHOMA COUNTY
DRAWN	-	-	TYPICAL SECTIONS (RAMP 'H')	
CHECKED	-	-		
APPROVED	-	-		
SQUAD	POE		STATE JOB NO. 09032108	SHEET NO. 0016

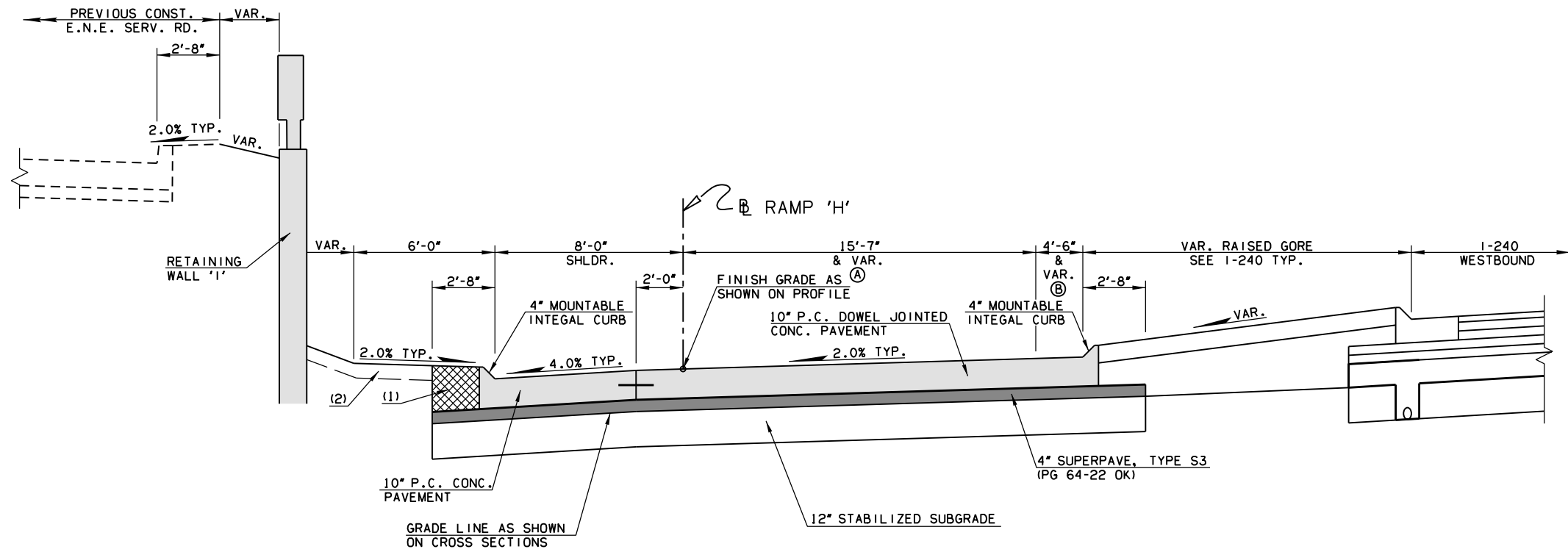

39 TYPICAL SECTION
RAMP 'H'
STA. 443+42.15 TO STA. 443+81.26

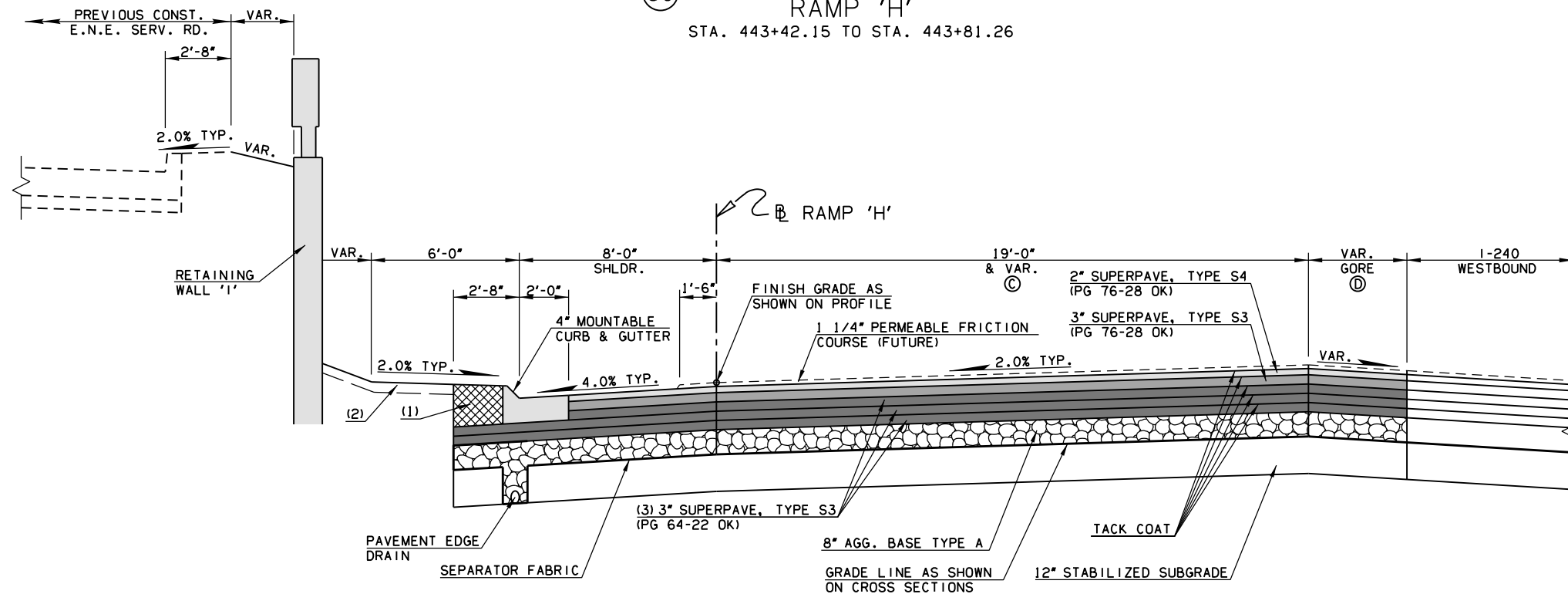

40 TYPICAL SECTION
RAMP 'H'
STA. 443+81.26 TO STA. 444+92.49

SEGMENT	VARIABLE WIDTH	STATION EXTENTS
A	15'-7" TO 17'-0"	443+42.15 TO 443+81.26
B	4'-6" TO 6'-0"	443+42.15 TO 443+81.26
C	17'-0" TO 19'-0"	443+81.26 TO 444+30.84
C	19'-0"	444+30.84 TO 444+92.49
D	20'-0" TO 10'-0"	443+81.26 TO 444+92.49

NOTE: VAR. NOT SHOWN SEE PLANS/DETAILS FOR MORE INFORMATION

(1) TO BE BACKFILLED AND COMPACTED AS PART OF FINISHING OPERATIONS. QUANTITY IS MEASURED IN UNCLASSIFIED BORROW.

(2) TOPSOIL NOTE:

THE CONTRACTOR SHALL STRIP ALL OF THE AVAILABLE TOPSOIL, STOCKPILE IT, AND PLACE IT BACK ON THE SECTION IN ACCORDANCE WITH SECTION 205 OF THE STANDARD SPECIFICATIONS. RESERVED TOPSOIL SHALL BE SPREAD FIRST ON THE COMPLETED SLOPES OF THE CUT SECTIONS AND THE REMAINDER ON COMPLETED FILL SLOPES OR OTHER PRIORITY AREAS LOCATED BY THE ENGINEER. ALL ADDITIONAL COSTS ASSOCIATED WITH OPERATION SHALL BE INCLUDED IN THE PAY ITEM FOR SALVAGED TOPSOIL, LUMP SUM.

(3) INTERSECTION OF CUT AND/OR FILL SLOPES WITH GROUND LINE TO BE ROUNDED AS PART OF FINISHING OPERATIONS. ROUNDED SHALL BE 5' MIN. FOR SMALLER CUTS AND FILLS, TO 15' MAX. FOR LARGER CUTS AND FILLS, OR AS DESIGNATED BY THE ENGINEER. COST OF ROUNDED TO BE INCLUDED IN PRICE BID FOR OTHER ITEMS OF WORK. SEE ROUNDED DETAIL ON OTHER TYPICAL SHEETS.

(4) TO BE BACKFILLED AND COMPACTED AS PART OF FINISHING OPERATIONS. QUANTITY IS MEASURED IN T.B.S.C. TYPE E.

DESIGN	-	-	PHASE 4	OKLAHOMA COUNTY
DRAWN	-	-	TYPICAL SECTIONS (RAMP 'H')	
CHECKED	-	-		
APPROVED	-	-		
SQUAD	POE			
			STATE JOB NO. 09032108	SHEET NO. 0017

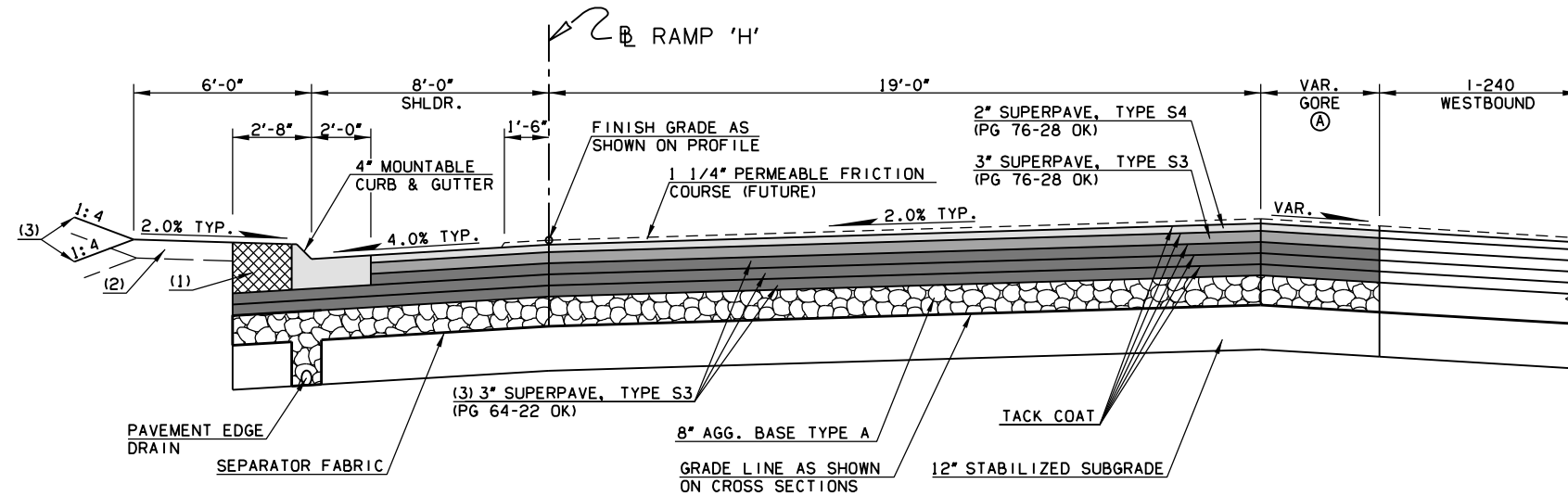

41 TYPICAL SECTION
RAMP 'H'
STA. 444+92.49 TO STA. 446+43.22

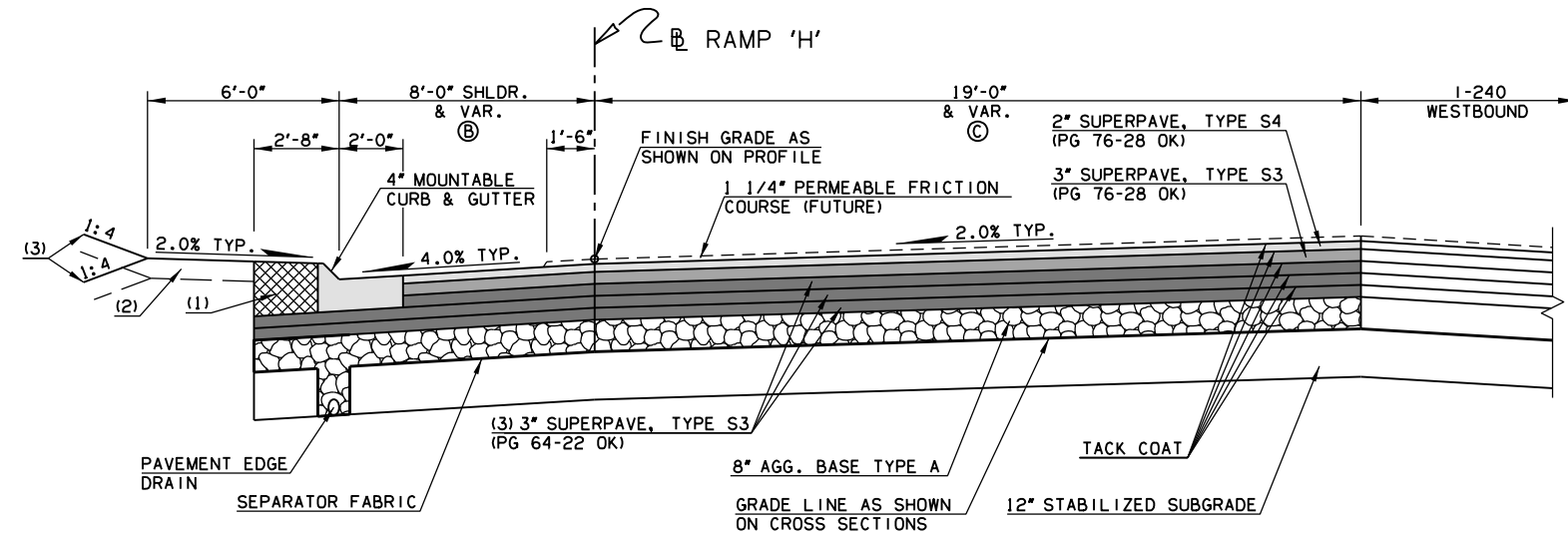

42 TYPICAL SECTION
RAMP 'H'
STA. 446+43.22 TO STA. 449+30.83

SEGMENT	VARIABLE WIDTH	STATION EXTENTS
A	10'-0" TO 0'-0"	444+92.49 TO 446+43.22
B	8'-0"	446+43.22 TO 449+00.23
B	8'-0" TO 10'-0"	449+00.23 TO 449+30.17
C	19'-0" TO 0'-0"	446+43.22 TO 449+30.83

NOTE: VAR. NOT SHOWN SEE PLANS/DETAILS FOR MORE INFORMATION

(1) TO BE BACKFILLED AND COMPACTED AS PART OF FINISHING OPERATIONS. QUANTITY IS MEASURED IN UNCLASSIFIED BORROW.

(2) TOPSOIL NOTE:

THE CONTRACTOR SHALL STRIP ALL OF THE AVAILABLE TOPSOIL, STOCKPILE IT, AND PLACE IT BACK ON THE SECTION IN ACCORDANCE WITH SECTION 205 OF THE STANDARD SPECIFICATIONS. RESERVED TOPSOIL SHALL BE SPREAD FIRST ON THE COMPLETED SLOPES OF THE CUT SECTIONS AND THE REMAINDER ON COMPLETED FILL SLOPES OR OTHER PRIORITY AREAS LOCATED BY THE ENGINEER. ALL ADDITIONAL COSTS ASSOCIATED WITH OPERATION SHALL BE INCLUDED IN THE PAY ITEM FOR SALVAGED TOPSOIL, LUMP SUM.

(3) INTERSECTION OF CUT AND/OR FILL SLOPES WITH GROUND LINE TO BE ROUNDED AS PART OF FINISHING OPERATIONS. ROUNDED SHALL BE 5' MIN. FOR SMALLER CUTS AND FILLS, TO 15' MAX. FOR LARGER CUTS AND FILLS, OR AS DESIGNATED BY THE ENGINEER. COST OF ROUNDED TO BE INCLUDED IN PRICE BID FOR OTHER ITEMS OF WORK. SEE ROUNDED DETAIL ON OTHER TYPICAL SHEETS.

(4) TO BE BACKFILLED AND COMPACTED AS PART OF FINISHING OPERATIONS. QUANTITY IS MEASURED IN T.B.S.C. TYPE E.

DESIGN	-	-	PHASE 4	OKLAHOMA COUNTY
DRAWN	-	-	TYPICAL SECTIONS (RAMP 'H')	
CHECKED	-	-		
APPROVED	-	-		
SQUAD	POE			
			STATE JOB NO. 09032108	SHEET NO. 0018

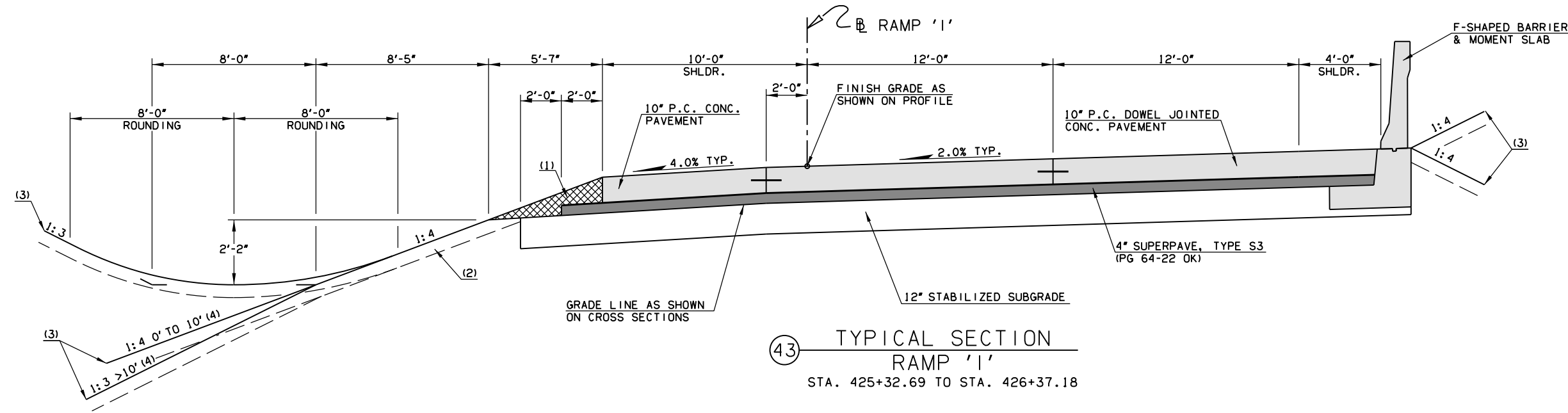

43 TYPICAL SECTION
RAMP '1'
STA. 425+32.69 TO STA. 426+37.18

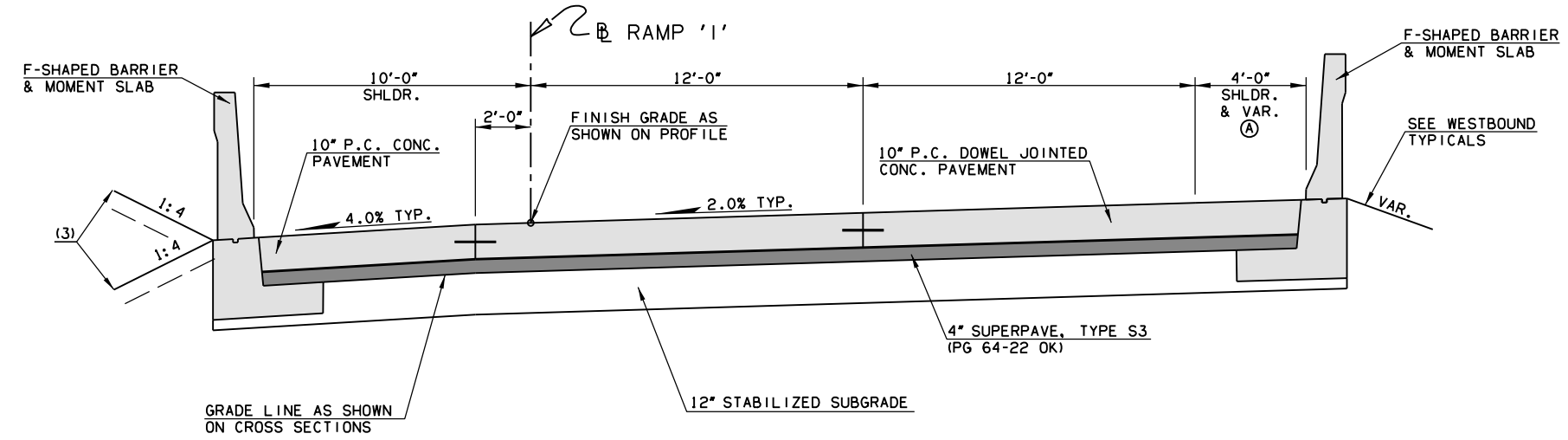

44 TYPICAL SECTION
RAMP '1'
STA. 430+05.68 TO STA. 434+59.79

SEGMENT	VARIABLE WIDTH	STATION EXTENTS
A	4'-0" TO 13'-0"	430+05.68 TO 434+59.79

NOTE: VAR. NOT SHOWN SEE PLANS/DETAILS FOR MORE INFORMATION

(1) TO BE BACKFILLED AND COMPACTED AS PART OF FINISHING OPERATIONS. QUANTITY IS MEASURED IN UNCLASSIFIED BORROW.

(2) **TOPSOIL NOTE:**
THE CONTRACTOR SHALL STRIP ALL OF THE AVAILABLE TOPSOIL, STOCKPILE IT, AND PLACE IT BACK ON THE SECTION IN ACCORDANCE WITH SECTION 205 OF THE STANDARD SPECIFICATIONS. RESERVED TOPSOIL SHALL BE SPREAD FIRST ON THE COMPLETED SLOPES OF THE CUT SECTIONS AND THE REMAINDER ON COMPLETED FILL SLOPES OR OTHER PRIORITY AREAS LOCATED BY THE ENGINEER. ALL ADDITIONAL COSTS ASSOCIATED WITH OPERATION SHALL BE INCLUDED IN THE PAY ITEM FOR SALVAGED TOPSOIL, LUMP SUM.

(3) INTERSECTION OF CUT AND/OR FILL SLOPES WITH GROUND LINE TO BE ROUNDED AS PART OF FINISHING OPERATIONS. ROUNDDING SHALL BE 5' MIN. FOR SMALLER CUTS AND FILLS, TO 15' MAX. FOR LARGER CUTS AND FILLS, OR AS DESIGNATED BY THE ENGINEER. COST OF ROUNDDING TO BE INCLUDED IN PRICE BID FOR OTHER ITEMS OF WORK. SEE ROUNDDING DETAIL ON OTHER TYPICAL SHEETS.

(4) TO BE BACKFILLED AND COMPACTED AS PART OF FINISHING OPERATIONS. QUANTITY IS MEASURED IN T.B.S.C. TYPE E.

DESIGN	-	-	PHASE 4	OKLAHOMA COUNTY
DRAWN	-	-	TYPICAL SECTIONS (RAMP I)	
CHECKED	-	-		
APPROVED	-	-		
SQUAD	POE		STATE JOB NO. 09032108	SHEET NO. 0019

3/4/2024 2:54:03 PM
 H:\PROJECTS\2789_CrossRoads_Phase 4\Roadway\Drawings\0903208-Phase 4_TypSections.dgn

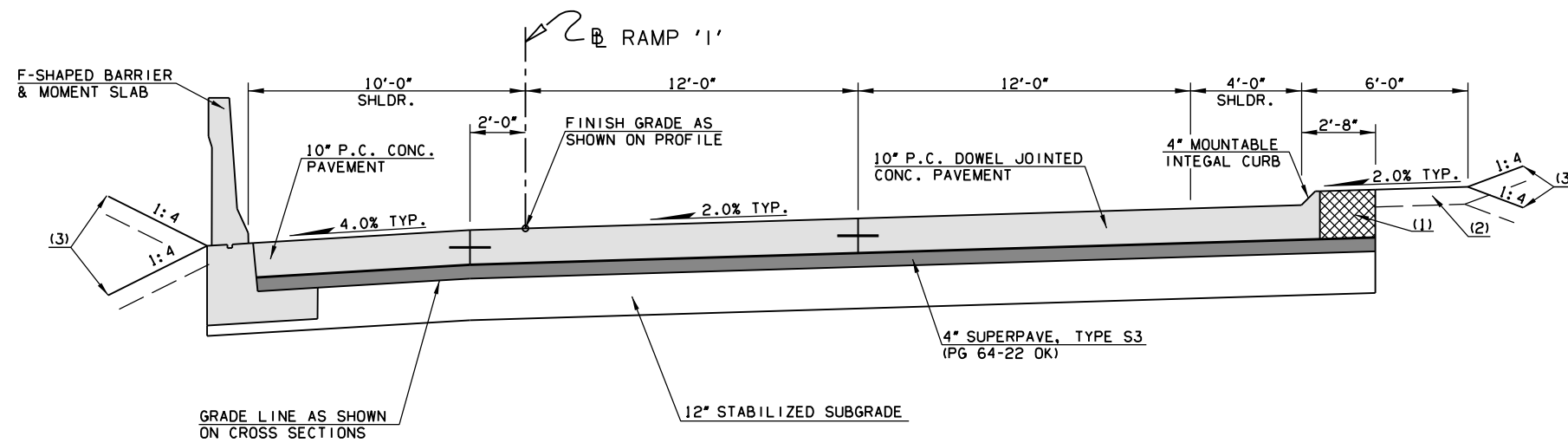

(45) TYPICAL SECTION
RAMP '1'
STA. 434+59.79 TO STA. 435+30.08

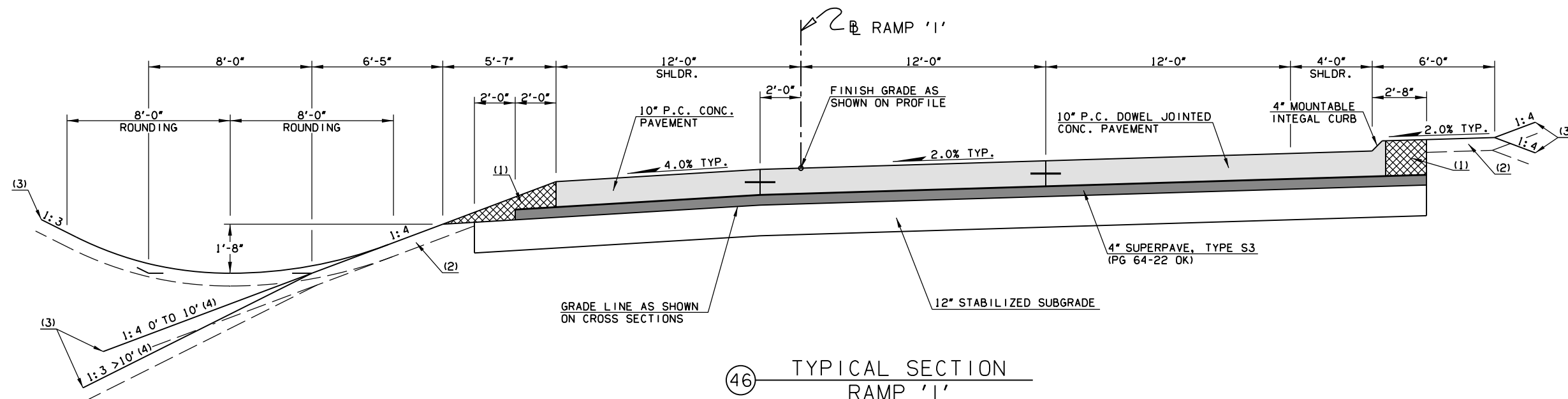

(46) TYPICAL SECTION
RAMP '1'
STA. 435+30.08 TO STA. 435+60.08

(1) TO BE BACKFILLED AND COMPACTED AS PART OF FINISHING OPERATIONS. QUANTITY IS MEASURED IN UNCLASSIFIED BORROW.

(2) TOPSOIL NOTE:

THE CONTRACTOR SHALL STRIP ALL OF THE AVAILABLE TOPSOIL, STOCKPILE IT, AND PLACE IT BACK ON THE SECTION IN ACCORDANCE WITH SECTION 205 OF THE STANDARD SPECIFICATIONS. RESERVED TOPSOIL SHALL BE SPREAD FIRST ON THE COMPLETED SLOPES OF THE CUT SECTIONS AND THE REMAINDER ON COMPLETED FILL SLOPES OR OTHER PRIORITY AREAS LOCATED BY THE ENGINEER. ALL ADDITIONAL COSTS ASSOCIATED WITH OPERATION SHALL BE INCLUDED IN THE PAY ITEM FOR SALVAGED TOPSOIL, LUMP SUM.

(3) INTERSECTION OF CUT AND/OR FILL SLOPES WITH GROUND LINE TO BE ROUNDED AS PART OF FINISHING OPERATIONS. ROUNDDING SHALL BE 5' MIN. FOR SMALLER CUTS AND FILLS, TO 15' MAX. FOR LARGER CUTS AND FILLS, OR AS DESIGNATED BY THE ENGINEER. COST OF ROUNDDING TO BE INCLUDED IN PRICE BID FOR OTHER ITEMS OF WORK. SEE ROUNDDING DETAIL ON OTHER TYPICAL SHEETS.

(4) TO BE BACKFILLED AND COMPACTED AS PART OF FINISHING OPERATIONS. QUANTITY IS MEASURED IN T.B.S.C. TYPE E.

DESIGN	-	-	PHASE 4	OKLAHOMA COUNTY
DRAWN	-	-	<p>TYPICAL SECTIONS (RAMP I)</p> <p>STATE JOB NO. 09032108 SHEET NO. 0020</p>	
CHECKED	-	-		
APPROVED	-	-		
SQUAD	POE			

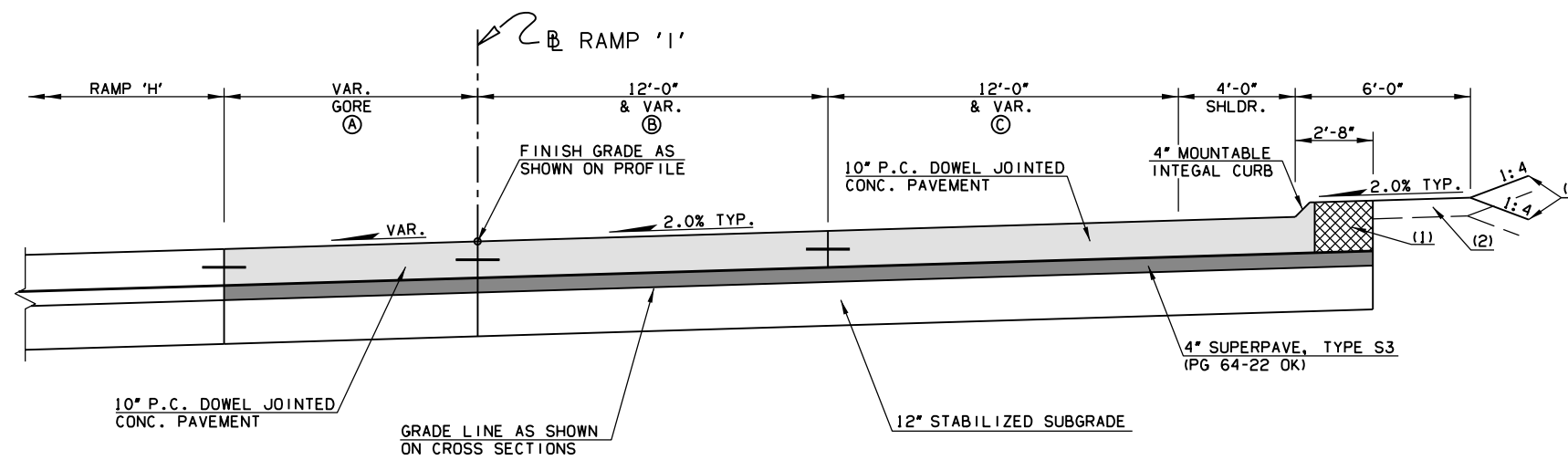

47 TYPICAL SECTION
RAMP 'I'
STA. 435+60.08 TO STA. 436+45.02

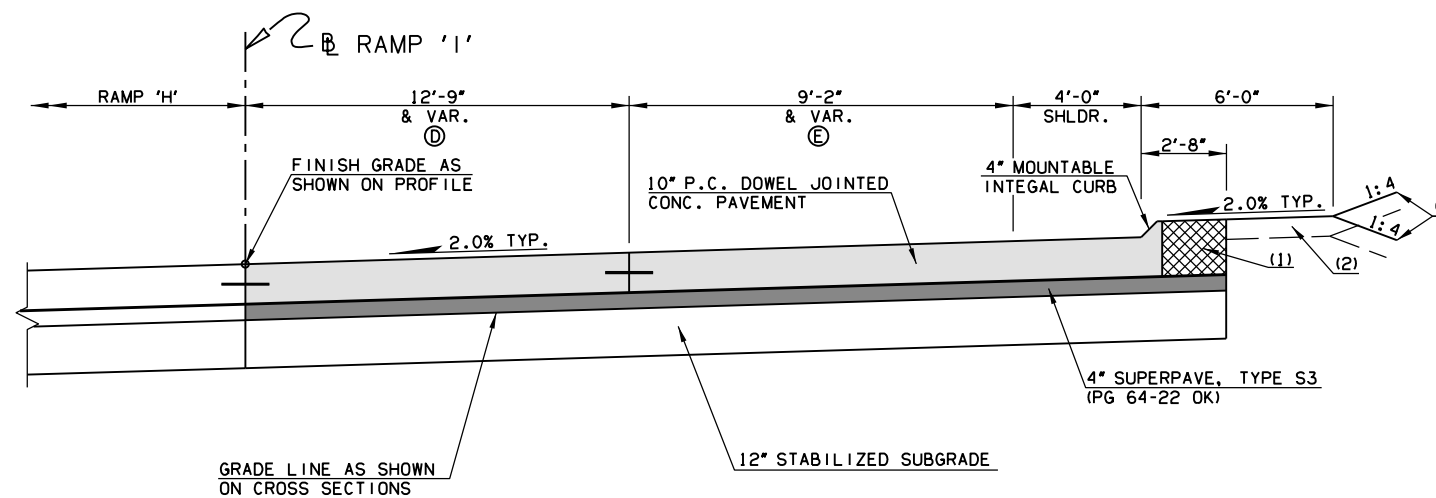

48 TYPICAL SECTION
RAMP 'I'
STA. 436+45.02 TO STA. 438+36.46

SEGMENT	VARIABLE WIDTH	STATION EXTENTS
A	21'-1" TO 0'-0"	435+60.08 TO 436+45.02
B	12'-0"	435+60.08 TO 435+85.08
B	12'-0" TO 12'-9"	435+85.08 TO 436+45.02
C	12'-0"	435+60.08 TO 435+85.08
C	12'-0" TO 9'-2"	435+85.08 TO 436+45.02
D	12'-9" TO 15'-0"	436+45.02 TO 438+36.46
E	9'-2" TO 0'-0"	436+45.02 TO 438+36.46

NOTE: VAR. NOT SHOWN SEE PLANS/DETAILS FOR MORE INFORMATION

(1) TO BE BACKFILLED AND COMPACTED AS PART OF FINISHING OPERATIONS. QUANTITY IS MEASURED IN UNCLASSIFIED BORROW.

(2) **TOPSOIL NOTE:**

THE CONTRACTOR SHALL STRIP ALL OF THE AVAILABLE TOPSOIL, STOCKPILE IT, AND PLACE IT BACK ON THE SECTION IN ACCORDANCE WITH SECTION 205 OF THE STANDARD SPECIFICATIONS. RESERVED TOPSOIL SHALL BE SPREAD FIRST ON THE COMPLETED SLOPES OF THE CUT SECTIONS AND THE REMAINDER ON COMPLETED FILL SLOPES OR OTHER PRIORITY AREAS LOCATED BY THE ENGINEER. ALL ADDITIONAL COSTS ASSOCIATED WITH OPERATION SHALL BE INCLUDED IN THE PAY ITEM FOR SALVAGED TOPSOIL, LUMP SUM.

(3) INTERSECTION OF CUT AND/OR FILL SLOPES WITH GROUND LINE TO BE ROUNDED AS PART OF FINISHING OPERATIONS. ROUNDED SHALL BE 5' MIN. FOR SMALLER CUTS AND FILLS, TO 15' MAX. FOR LARGER CUTS AND FILLS, OR AS DESIGNATED BY THE ENGINEER. COST OF ROUNDED TO BE INCLUDED IN PRICE BID FOR OTHER ITEMS OF WORK. SEE ROUNDED DETAIL ON OTHER TYPICAL SHEETS.

(4) TO BE BACKFILLED AND COMPACTED AS PART OF FINISHING OPERATIONS. QUANTITY IS MEASURED IN T.B.S.C. TYPE E.

DESIGN	-	-	PHASE 4	OKLAHOMA COUNTY
DRAWN	-	-	TYPICAL SECTIONS (RAMP I) STATE JOB NO. <u>09032108</u> SHEET NO. <u>0021</u>	
CHECKED	-	-		
APPROVED	-	-		
SQUAD	POE			

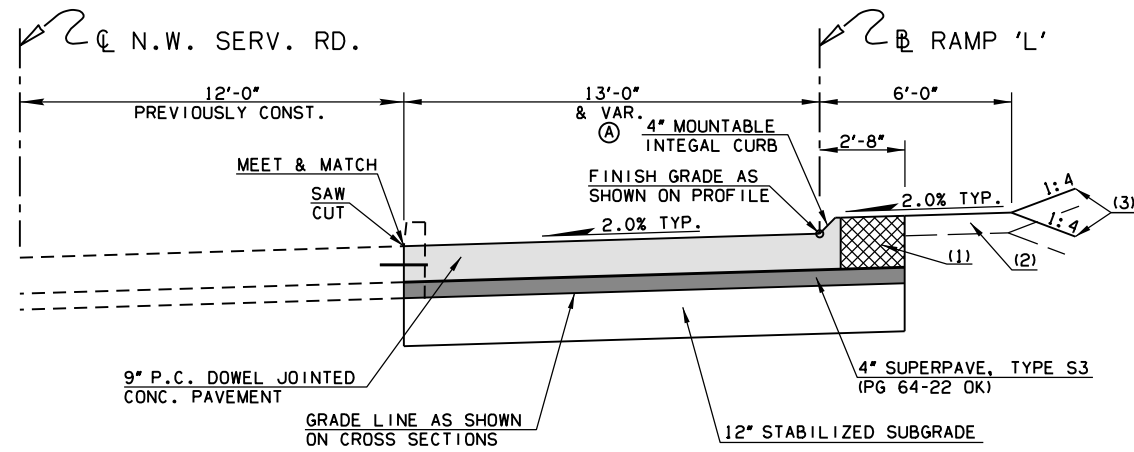

49 TYPICAL SECTION
RAMP 'L'
STA. 407+47.18 TO STA. 408+22.69

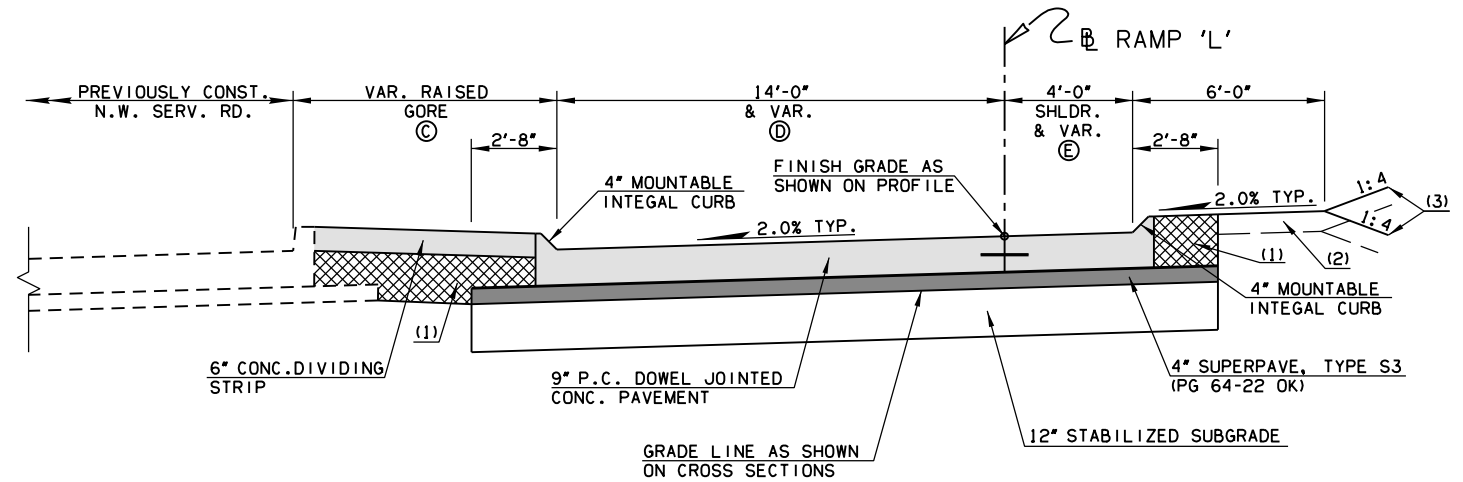

51 TYPICAL SECTION
RAMP 'L'
STA. 409+32.13 TO STA. 409+59.61

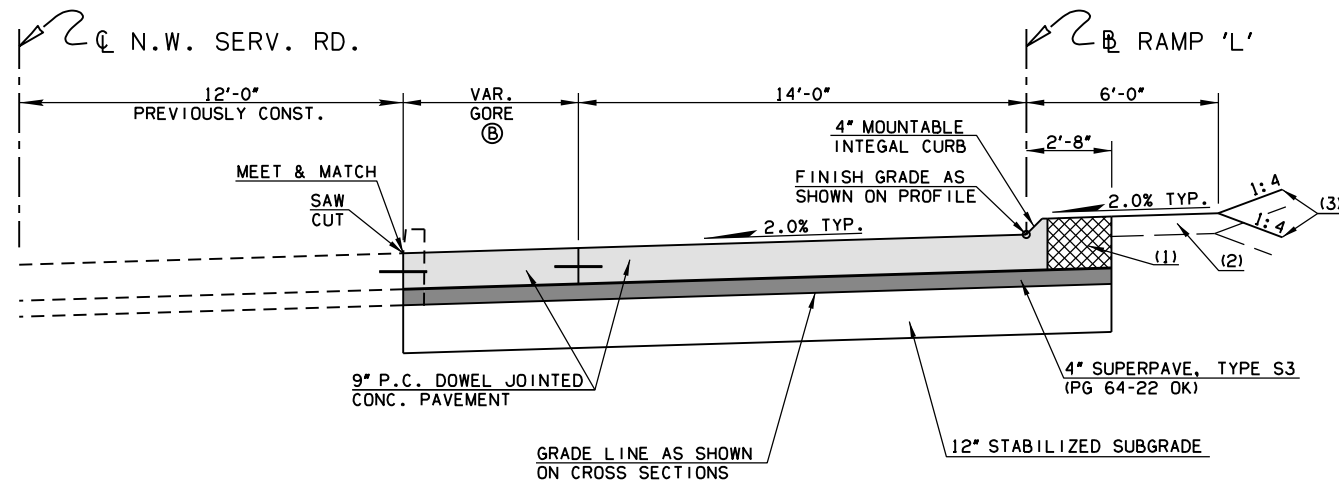

50 TYPICAL SECTION
RAMP 'L'
STA. 408+22.69 TO STA. 409+32.13

SEGMENT	VARIABLE WIDTH	STATION EXTENTS
A	13'-0" TO 14'-0"	407+47.18 TO 408+22.69
B	0'-0" TO 5'-0"	408+22.69 TO 409+32.13
C	4'-0" TO 5'-4"	409+32.13 TO 409+59.61
D	14'-0" TO 14'-7"	409+32.13 TO 409+59.61
E	0'-0" TO 4'-0"	409+32.13 TO 409+59.61

NOTE: VAR. NOT SHOWN SEE PLANS/DETAILS FOR MORE INFORMATION

(1) TO BE BACKFILLED AND COMPACTED AS PART OF FINISHING OPERATIONS. QUANTITY IS MEASURED IN UNCLASSIFIED BORROW.

(2) TOPSOIL NOTE:

THE CONTRACTOR SHALL STRIP ALL OF THE AVAILABLE TOPSOIL, STOCKPILE IT, AND PLACE IT BACK ON THE SECTION IN ACCORDANCE WITH SECTION 205 OF THE STANDARD SPECIFICATIONS. RESERVED TOPSOIL SHALL BE SPREAD FIRST ON THE COMPLETED SLOPES OF THE CUT SECTIONS AND THE REMAINDER ON COMPLETED FILL SLOPES OR OTHER PRIORITY AREAS LOCATED BY THE ENGINEER. ALL ADDITIONAL COSTS ASSOCIATED WITH OPERATION SHALL BE INCLUDED IN THE PAY ITEM FOR SALVAGED TOPSOIL, LUMP SUM.

(3) INTERSECTION OF CUT AND/OR FILL SLOPES WITH GROUND LINE TO BE ROUNDED AS PART OF FINISHING OPERATIONS. ROUNDED SHALL BE 5' MIN. FOR SMALLER CUTS AND FILLS, TO 15' MAX. FOR LARGER CUTS AND FILLS, OR AS DESIGNATED BY THE ENGINEER. COST OF ROUNDED TO BE INCLUDED IN PRICE BID FOR OTHER ITEMS OF WORK. SEE ROUNDED DETAIL ON OTHER TYPICAL SHEETS.

(4) TO BE BACKFILLED AND COMPACTED AS PART OF FINISHING OPERATIONS. QUANTITY IS MEASURED IN T.B.S.C. TYPE E.

DESIGN	-	-	PHASE 4	OKLAHOMA COUNTY
DRAWN	-	-	TYPICAL SECTIONS (RAMP L)	
CHECKED	-	-		
APPROVED	-	-		
SQUAD	POE		STATE JOB NO. 09032108	SHEET NO. 0022

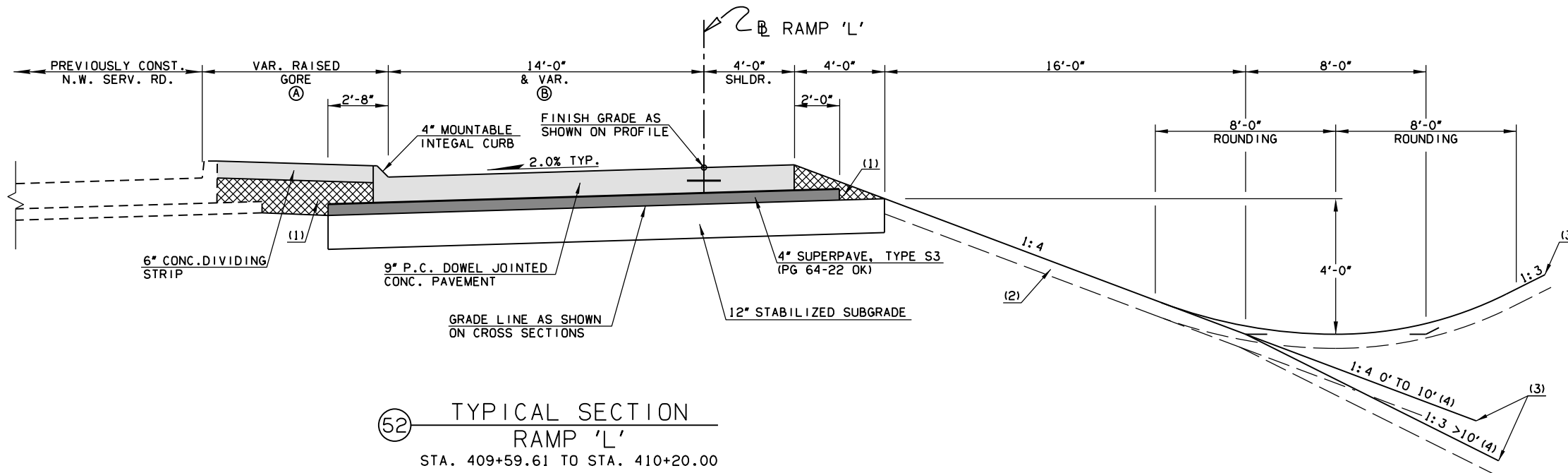

52 TYPICAL SECTION
RAMP 'L'
STA. 409+59.61 TO STA. 410+20.00

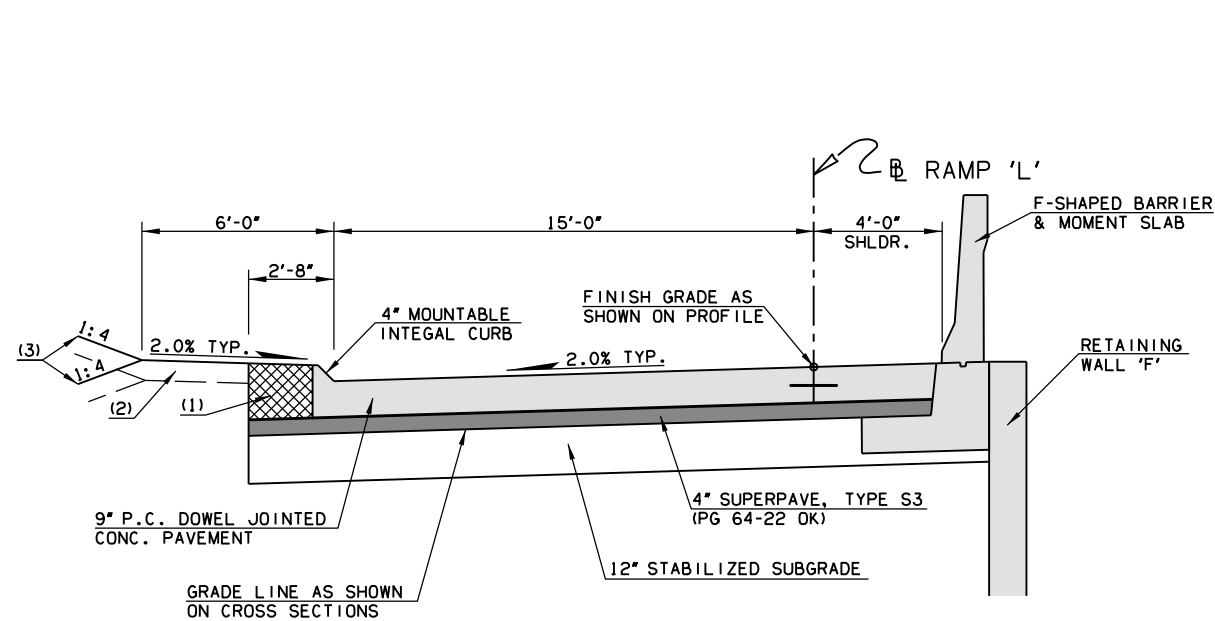

53 TYPICAL SECTION
RAMP 'L'
STA. 410+20.00 TO STA. 411+00.00

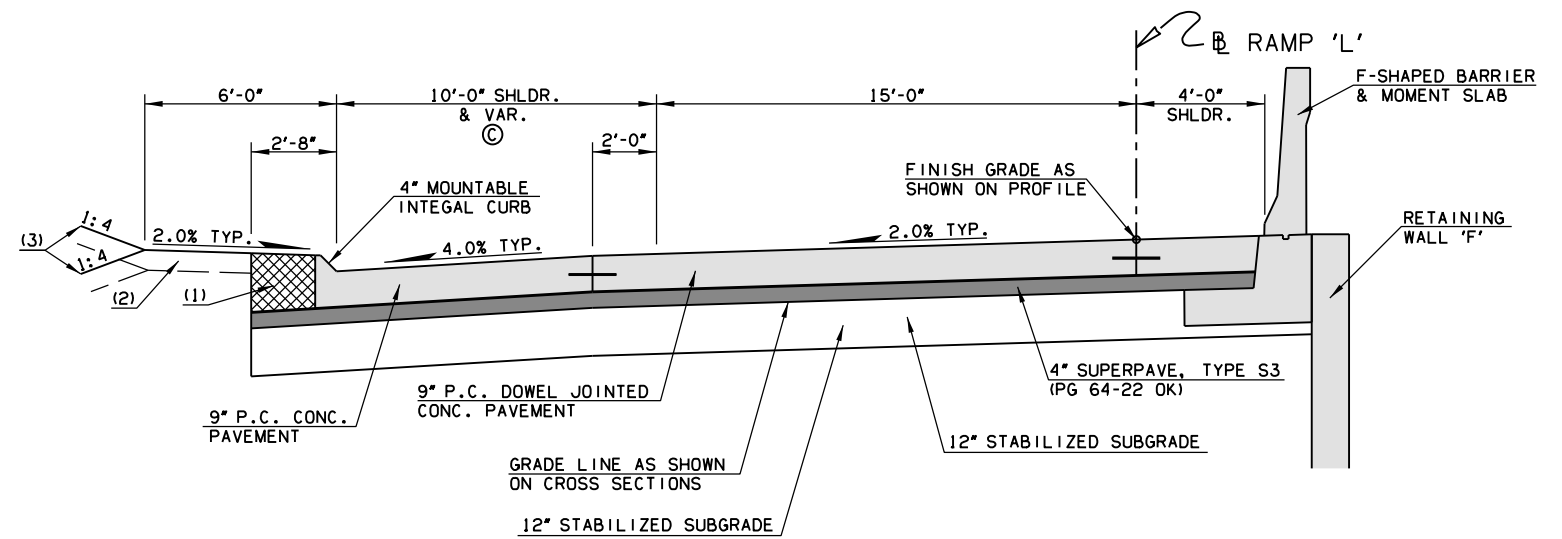

54 TYPICAL SECTION
RAMP 'L'
STA. 411+00.00 TO STA. 411+96.92

SEGMENT	VARIABLE WIDTH	STATION EXTENTS
A	5'-4" TO 10'-1"	409+59.61 TO 410+20.00
B	14'-7" TO 15'-0"	409+59.61 TO 409+82.11
B	15'-0"	409+82.11 TO 410+20.00
C	0'-0" TO 10'-0"	411+00.00 TO 411+50.00
C	10'-0"	411+50.00 TO 411+96.92

NOTE: VAR. NOT SHOWN SEE PLANS/DETAILS FOR MORE INFORMATION

(1) TO BE BACKFILLED AND COMPACTED AS PART OF FINISHING OPERATIONS. QUANTITY IS MEASURED IN UNCLASSIFIED BORROW.

(2) TOPSOIL NOTE:

THE CONTRACTOR SHALL STRIP ALL OF THE AVAILABLE TOPSOIL, STOCKPILE IT, AND PLACE IT BACK ON THE SECTION IN ACCORDANCE WITH SECTION 205 OF THE STANDARD SPECIFICATIONS. RESERVED TOPSOIL SHALL BE SPREAD FIRST ON THE COMPLETED SLOPES OF THE CUT SECTIONS AND THE REMAINDER ON COMPLETED FILL SLOPES OR OTHER PRIORITY AREAS LOCATED BY THE ENGINEER. ALL ADDITIONAL COSTS ASSOCIATED WITH OPERATION SHALL BE INCLUDED IN THE PAY ITEM FOR SALVAGED TOPSOIL, LUMP SUM.

(3) INTERSECTION OF CUT AND/OR FILL SLOPES WITH GROUND LINE TO BE ROUNDED AS PART OF FINISHING OPERATIONS. ROUNDDING SHALL BE 5' MIN. FOR SMALLER CUTS AND FILLS, TO 15' MAX. FOR LARGER CUTS AND FILLS, OR AS DESIGNATED BY THE ENGINEER. COST OF ROUNDDING TO BE INCLUDED IN PRICE BID FOR OTHER ITEMS OF WORK. SEE ROUNDDING DETAIL ON OTHER TYPICAL SHEETS.

(4) TO BE BACKFILLED AND COMPACTED AS PART OF FINISHING OPERATIONS. QUANTITY IS MEASURED IN T.B.S.C. TYPE E.

DESIGN	-	-	PHASE 4	OKLAHOMA COUNTY
DRAWN	-	-	TYPICAL SECTIONS (RAMP L)	
CHECKED	-	-		
APPROVED	-	-		
SQUAD	POE		STATE JOB NO. 09032108	SHEET NO. 0023

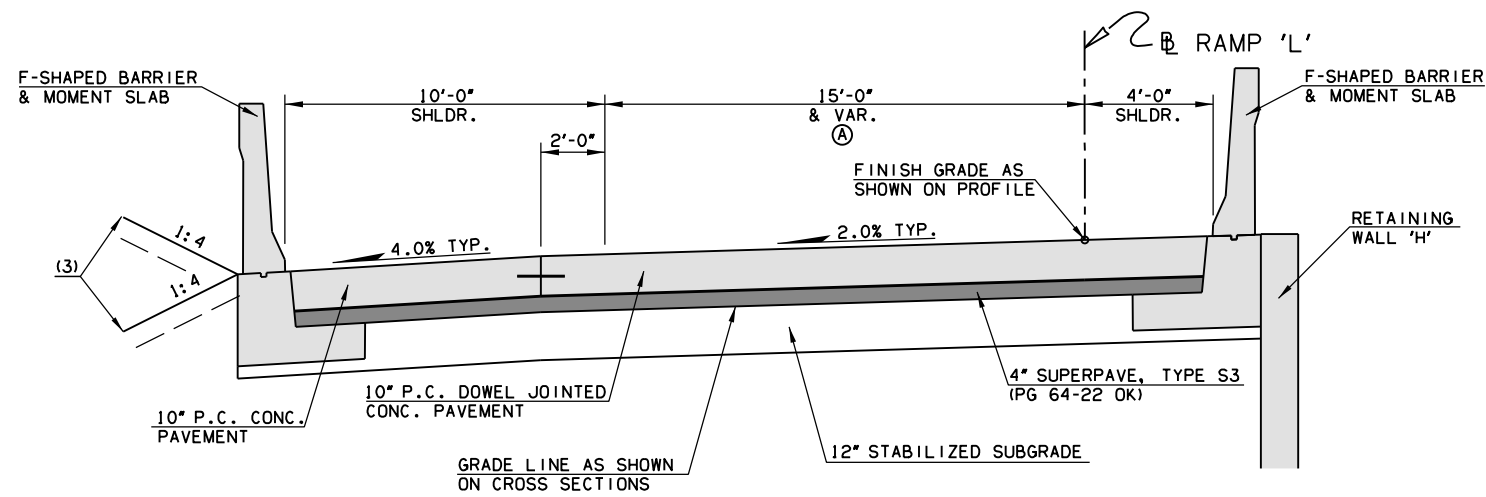

**(55) TYPICAL SECTION
RAMP 'L'**
STA. 416+70.42 TO STA. 417+64.18
STA. 422+00.00 TO STA. 422+09.18

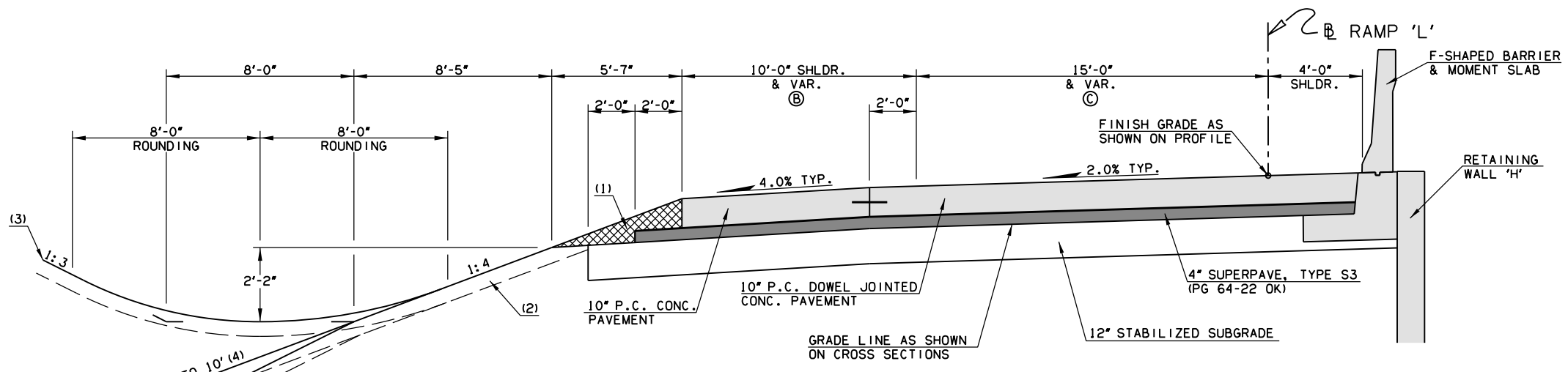

**(56) TYPICAL SECTION
RAMP 'L'**
STA. 417+64.18 TO STA. 422+00.00

SEGMENT	VARIABLE WIDTH	STATION EXTENTS
A	15'-0"	416+70.42 TO 417+64.18
A	19'-10" TO 20'-0"	422+00.00 TO 422+09.18
B	12'-0"	417+64.18 TO 417+94.18
B	12'-0" TO 10'-0"	417+94.18 TO 418+44.18
B	10'-0"	418+44.18 TO 422+00.00
C	15'-0"	417+64.18 TO 419+56.98
C	15'-0" TO 19'-10"	419+56.98 TO 422+00.00

NOTE: VAR. NOT SHOWN SEE PLANS/DETAILS FOR MORE INFORMATION

- (1) TO BE BACKFILLED AND COMPACTED AS PART OF FINISHING OPERATIONS. QUANTITY IS MEASURED IN UNCLASSIFIED BORROW.
- (2) **TOPSOIL NOTE:**
THE CONTRACTOR SHALL STRIP ALL OF THE AVAILABLE TOPSOIL, STOCKPILE IT, AND PLACE IT BACK ON THE SECTION IN ACCORDANCE WITH SECTION 205 OF THE STANDARD SPECIFICATIONS. RESERVED TOPSOIL SHALL BE SPREAD FIRST ON THE COMPLETED SLOPES OF THE CUT SECTIONS AND THE REMAINDER ON COMPLETED FILL SLOPES OR OTHER PRIORITY AREAS LOCATED BY THE ENGINEER. ALL ADDITIONAL COSTS ASSOCIATED WITH OPERATION SHALL BE INCLUDED IN THE PAY ITEM FOR SALVAGED TOPSOIL, LUMP SUM.
- (3) INTERSECTION OF CUT AND/OR FILL SLOPES WITH GROUND LINE TO BE ROUNDED AS PART OF FINISHING OPERATIONS. ROUNDDING SHALL BE 5' MIN. FOR SMALLER CUTS AND FILLS, TO 15' MAX. FOR LARGER CUTS AND FILLS, OR AS DESIGNATED BY THE ENGINEER. COST OF ROUNDDING TO BE INCLUDED IN PRICE BID FOR OTHER ITEMS OF WORK. SEE ROUNDDING DETAIL ON OTHER TYPICAL SHEETS.
- (4) TO BE BACKFILLED AND COMPACTED AS PART OF FINISHING OPERATIONS. QUANTITY IS MEASURED IN T.B.S.C. TYPE E.

DESIGN	-	-	PHASE 4	OKLAHOMA COUNTY
DRAWN	-	-	TYPICAL SECTIONS (RAMP L) STATE JOB NO. 09032108 SHEET NO. 0024	
CHECKED	-	-		
APPROVED	-	-		
SQUAD	POE			

3/4/2024 2:24:06 PM H:\PROJECTS\2789_CrossRoads_Phase 4\Roadway\Drawings\0903208-Phase 4_TypSections.dgn

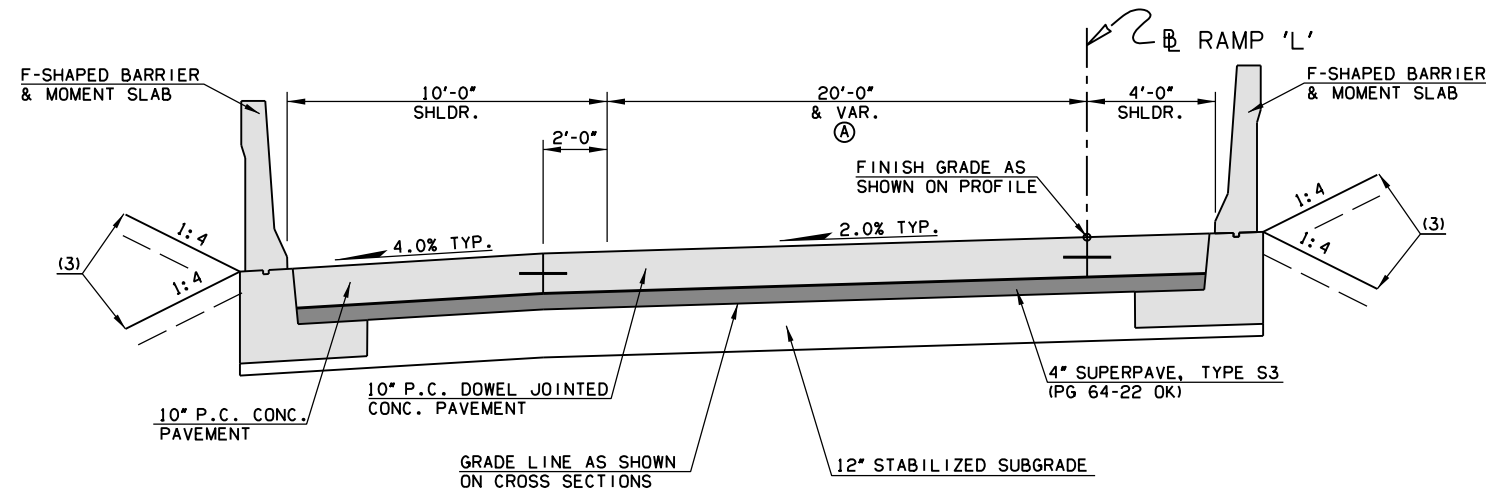

(57) TYPICAL SECTION
RAMP 'L'
STA. 422+09.18 TO STA. 423+33.00

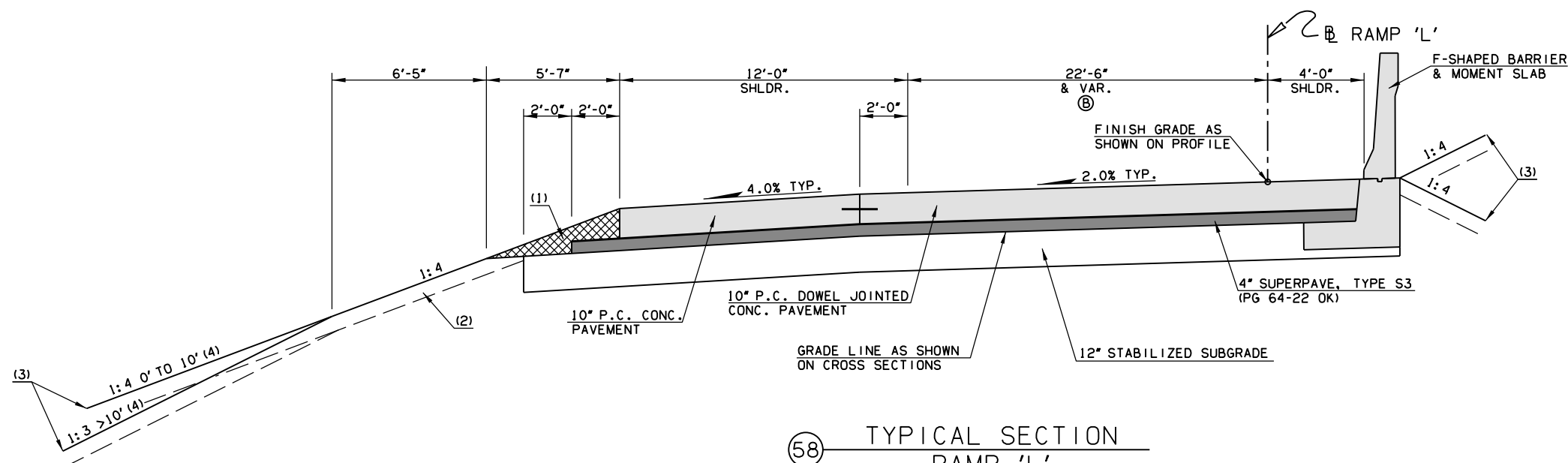

(58) TYPICAL SECTION
RAMP 'L'
STA. 423+33.00 TO STA. 423+94.08

SEGMENT	VARIABLE WIDTH	STATION EXTENTS
A	20'-0" TO 22'-6"	422+09.18 TO 423+33.00
B	22'-6" TO 23'-9"	423+33.00 TO 423+94.08

NOTE: VAR. NOT SHOWN SEE PLANS/DETAILS FOR MORE INFORMATION

(1) TO BE BACKFILLED AND COMPACTED AS PART OF FINISHING OPERATIONS. QUANTITY IS MEASURED IN UNCLASSIFIED BORROW.

(2) TOPSOIL NOTE:

THE CONTRACTOR SHALL STRIP ALL OF THE AVAILABLE TOPSOIL, STOCKPILE IT, AND PLACE IT BACK ON THE SECTION IN ACCORDANCE WITH SECTION 205 OF THE STANDARD SPECIFICATIONS. RESERVED TOPSOIL SHALL BE SPREAD FIRST ON THE COMPLETED SLOPES OF THE CUT SECTIONS AND THE REMAINDER ON COMPLETED FILL SLOPES OR OTHER PRIORITY AREAS LOCATED BY THE ENGINEER. ALL ADDITIONAL COSTS ASSOCIATED WITH OPERATION SHALL BE INCLUDED IN THE PAY ITEM FOR SALVAGED TOPSOIL, LUMP SUM.

(3) INTERSECTION OF CUT AND/OR FILL SLOPES WITH GROUND LINE TO BE ROUNDED AS PART OF FINISHING OPERATIONS. ROUNDED SHALL BE 5' MIN. FOR SMALLER CUTS AND FILLS, TO 15' MAX. FOR LARGER CUTS AND FILLS, OR AS DESIGNATED BY THE ENGINEER. COST OF ROUNDED TO BE INCLUDED IN PRICE BID FOR OTHER ITEMS OF WORK. SEE ROUNDED DETAIL ON OTHER TYPICAL SHEETS.

(4) TO BE BACKFILLED AND COMPACTED AS PART OF FINISHING OPERATIONS. QUANTITY IS MEASURED IN T.B.S.C. TYPE E.

DESIGN	-	-	PHASE 4	OKLAHOMA COUNTY
DRAWN	-	-	TYPICAL SECTIONS (RAMP L)	
CHECKED	-	-		
APPROVED	-	-		
SQUAD	POE		STATE JOB NO. 09032108	SHEET NO. 0025

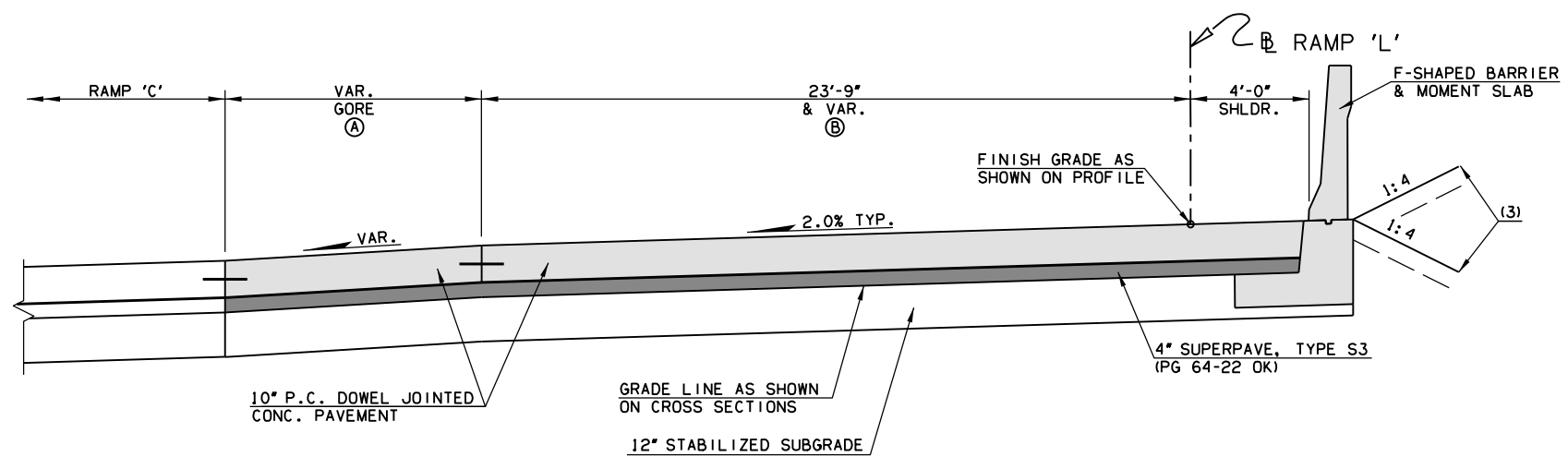

**(59) TYPICAL SECTION
RAMP 'L'**
STA. 423+94.08 TO STA. 424+37.29

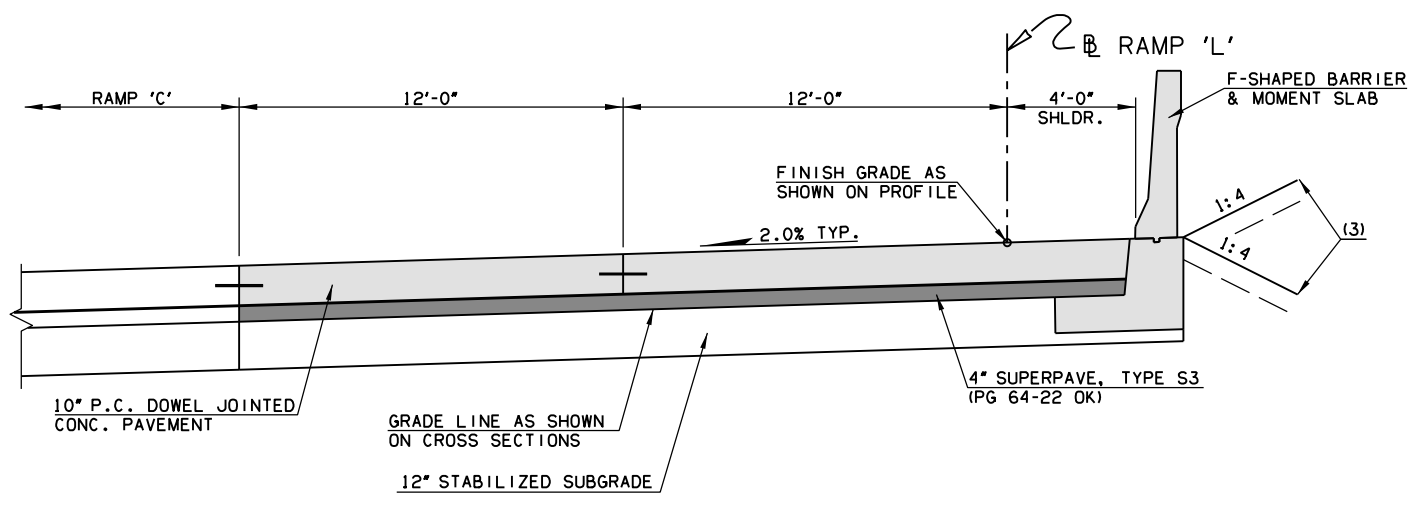

**(60) TYPICAL SECTION
RAMP 'L'**
STA. 424+37.29 TO STA. 425+32.69

SEGMENT	VARIABLE WIDTH	STATION EXTENTS
A	24'-0" TO 0'-0"	423+94.08 TO 424+37.29
B	23'-9" TO 24'-0"	423+94.08 TO 424+08.81
B	24'-0"	424+08.81 TO 424+37.29

NOTE: VAR. NOT SHOWN SEE PLANS/DETAILS FOR MORE INFORMATION

(1) TO BE BACKFILLED AND COMPACTED AS PART OF FINISHING OPERATIONS. QUANTITY IS MEASURED IN UNCLASSIFIED BORROW.

(2) TOPSOIL NOTE:

THE CONTRACTOR SHALL STRIP ALL OF THE AVAILABLE TOPSOIL, STOCKPILE IT, AND PLACE IT BACK ON THE SECTION IN ACCORDANCE WITH SECTION 205 OF THE STANDARD SPECIFICATIONS. RESERVED TOPSOIL SHALL BE SPREAD FIRST ON THE COMPLETED SLOPES OF THE CUT SECTIONS AND THE REMAINDER ON COMPLETED FILL SLOPES OR OTHER PRIORITY AREAS LOCATED BY THE ENGINEER. ALL ADDITIONAL COSTS ASSOCIATED WITH OPERATION SHALL BE INCLUDED IN THE PAY ITEM FOR SALVAGED TOPSOIL, LUMP SUM.

(3) INTERSECTION OF CUT AND/OR FILL SLOPES WITH GROUND LINE TO BE ROUNDED AS PART OF FINISHING OPERATIONS. ROUNDED SHALL BE 5' MIN. FOR SMALLER CUTS AND FILLS, TO 15' MAX. FOR LARGER CUTS AND FILLS, OR AS DESIGNATED BY THE ENGINEER. COST OF ROUNDED TO BE INCLUDED IN PRICE BID FOR OTHER ITEMS OF WORK. SEE ROUNDED DETAIL ON OTHER TYPICAL SHEETS.

(4) TO BE BACKFILLED AND COMPACTED AS PART OF FINISHING OPERATIONS. QUANTITY IS MEASURED IN T.B.S.C. TYPE E.

DESIGN	-	-	PHASE 4	OKLAHOMA COUNTY
DRAWN	-	-	TYPICAL SECTIONS (RAMP L) STATE JOB NO. <u>09032108</u> SHEET NO. <u>0026</u>	
CHECKED	-	-		
APPROVED	-	-		
SQUAD	POE			

3/4/2024 2:34:07 PM
 H:\PROJECTS\2785_CrossRoads_Phase 4\Roadway\Drawings\0903208-Phase 4_TypSections.dgn

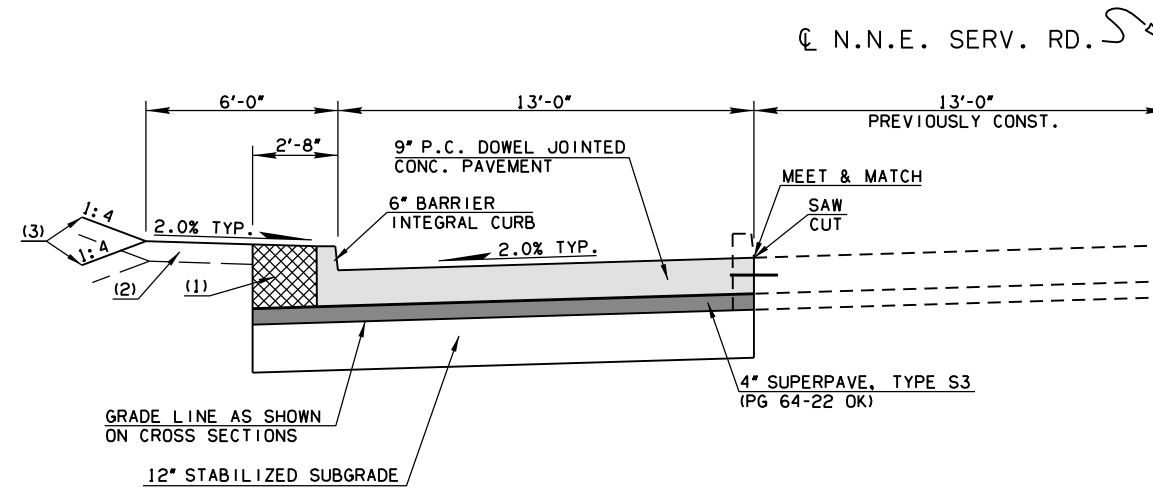

⑥1 TYPICAL SECTION
N.N.E. SERVICE ROAD
STA. 94+40.74 TO STA. 97+04.14

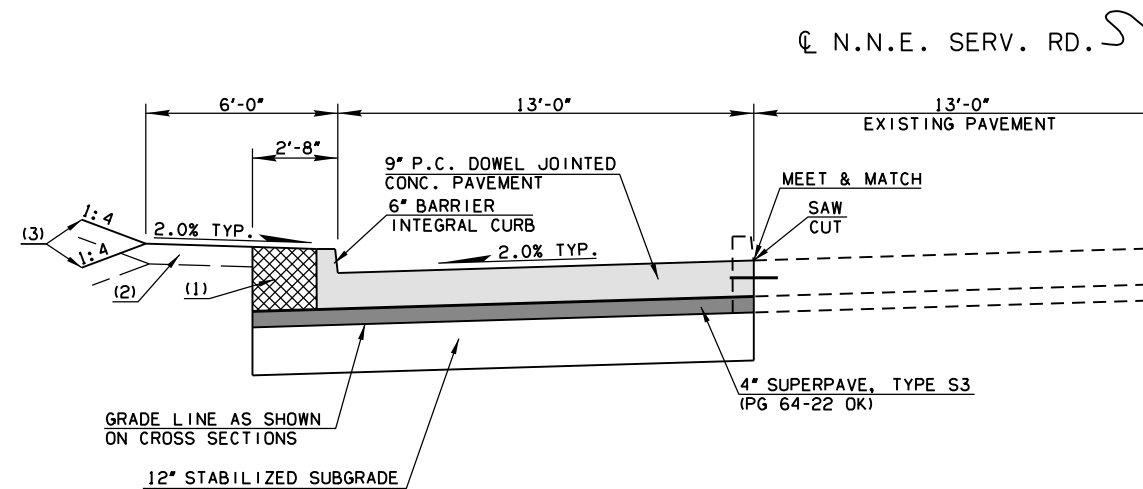

⑥2 TYPICAL SECTION
N.N.E. SERVICE ROAD
STA. 97+04.14 TO STA. 103+56.13

(1) TO BE BACKFILLED AND COMPACTED AS PART OF FINISHING OPERATIONS. QUANTITY IS MEASURED IN UNCLASSIFIED BORROW.

(2) TOPSOIL NOTE:

THE CONTRACTOR SHALL STRIP ALL OF THE AVAILABLE TOPSOIL, STOCKPILE IT, AND PLACE IT BACK ON THE SECTION IN ACCORDANCE WITH SECTION 205 OF THE STANDARD SPECIFICATIONS. RESERVED TOPSOIL SHALL BE SPREAD FIRST ON THE COMPLETED SLOPES OF THE CUT SECTIONS AND THE REMAINDER ON COMPLETED FILL SLOPES OR OTHER PRIORITY AREAS LOCATED BY THE ENGINEER. ALL ADDITIONAL COSTS ASSOCIATED WITH OPERATION SHALL BE INCLUDED IN THE PAY ITEM FOR SALVAGED TOPSOIL, LUMP SUM.

(3) INTERSECTION OF CUT AND/OR FILL SLOPES WITH GROUND LINE TO BE ROUNDED AS PART OF FINISHING OPERATIONS. ROUNDED SHALL BE 5' MIN. FOR SMALLER CUTS AND FILLS, TO 15' MAX. FOR LARGER CUTS AND FILLS, OR AS DESIGNATED BY THE ENGINEER. COST OF ROUNDED TO BE INCLUDED IN PRICE BID FOR OTHER ITEMS OF WORK. SEE ROUNDED DETAIL ON OTHER TYPICAL SHEETS.

(4) TO BE BACKFILLED AND COMPACTED AS PART OF FINISHING OPERATIONS. QUANTITY IS MEASURED IN T.B.S.C. TYPE E.

DESIGN	-	-	PHASE 4	OKLAHOMA COUNTY
DRAWN	-	-	TYPICAL SECTIONS (N.N.E. SERVICE ROADS) STATE JOB NO. 09032108 SHEET NO. 0027	
CHECKED	-	-		
APPROVED	-	-		
SQUAD	POE			

(BR-1) PAYMENT FOR THIS ITEM WILL BE BASED ON PLAN QUANTITY. SEE THE 2019 OKLAHOMA STANDARD SPECIFICATIONS FOR HIGHWAY CONSTRUCTION - "PLAN QUANTITIES", SECTION 109.01.B.

(BR-2) THE ESTIMATED TOTAL OF STRUCTURAL STEEL FOR EACH STAINLESS STEEL BEARING ASSEMBLY IS PROVIDED IN THE FOLLOWING TABLE BY LOCATION, SPAN AND TYPE.

LOCATION:	PIER 6	PIER 7		PIER 8		PIER 9	PIER 10		PIER 11	PIER 12		PIER 13	ABUT 2
SPAN:	7	7	8	8	9	9 OR 10	10	11	11 OR 12	12	13	13 OR 14	14
TYPE:	FIX	EXP	EXP	FIX	EXP	FIX	EXP	EXP	FIX	EXP	EXP	EXP	FIX
WEIGHT:	260 LBS	260 LBS	269 LBS	269 LBS	269 LBS	395 LBS	269 LBS	269 LBS	395 LBS	269 LBS	245 LBS	331 LBS	245 LBS

(BR-3) THIS ITEM CONTAINS AN ESTIMATED TOTAL OF 39.5 C.Y. CLASS AA CONCRETE AND 7450 LB. OF EPOXY COATED REINFORCING STEEL.

(BR-4) PRICE BID FOR THESE ITEMS SHALL INCLUDE THE COST OF INSTALLING FORM LINERS AND STAINING SURFACES AS STATED IN THE SPECIAL PROVISION "CONCRETE, MISC.: AESTHETIC TREATMENTS".

(BR-5) QUANTITY SHOWN FOR SEALER RESIN IS ESTIMATED AT 0.11 GALLONS PER FOOT OF JOINT.

(BR-6) STEEL PILES SHALL CONFORM TO AASHTO M270 (ASTM A709) GRADE 50.

(BR-7) THIS ITEM INCLUDES 33 FT. OF PERFORATED PIPE AND 5 C.Y. OF PIPE UNDERDRAIN MATERIAL FOR THE ABUTMENT.

(BR-8) THIS ITEM INCLUDES 20 FT. OF NON-PERFORATED PIPE AND 5 C.Y. OF TRENCH EXCAVATION AND 5 C.Y. OF STANDARD BEDDING MATERIAL FOR THE ABUTMENT.

I/P NO. 09032(08) 0200 BRIDGE "A"		PAY QUANTITIES		OKLAHOMA COUNTY	
RAMP "A" AT I-35 & I-240 INTERCHANGE STEEL GIRDER SPANS; CURVED VARIABLE CLEAR ROADWAY WITH 42" F-SHAPED PARAPET					
ITEM NO.		ITEM		UNIT	TOTAL
501(B)	1300	SUBSTRUCTURE EXCAVATION COMMON	(BR-1)	C.Y.	545.00
501(C)	1400	SUBSTRUCTURE EXCAVATION ROCK		C.Y.	10.00
501(G)	1800	CLSM BACKFILL	(BR-1)	C.Y.	97.50
504(A)	5200	APPROACH SLAB	(BR-1)(BR-3)	S.Y.	109.40
504(B)	5300	SAW-CUT GROOVING	(BR-1)	S.Y.	4,681.00
504(E)	5520	42" F-SHAPED PARAPET	(BR-1)(BR-4)	L.F.	2,227.30
506(A)	7205	STRUCTURAL STEEL M270 GRADE 50W	(BR-1)	LB.	2,566,130.00
507(A)	8200	STAINLESS STEEL FIXED BEARING ASSEMBLY	(BR-2)	EA.	28.00
507(B)	8300	STAINLESS STEEL EXP. BEARING ASSEMBLY	(BR-2)	EA.	40.00
509(A)	0210	CLASS AA CONCRETE	(BR-1)(BR-4)	C.Y.	1,303.30
509(B)	0510	CLASS A CONCRETE	(BR-1)(BR-4)	C.Y.	676.90
510(C)	1450	SLOPE WALL (5")		S.Y.	272.00
510(D)	1500	GRAFFITI TREATMENT		S.F.	34,426.00
511(A)	2210	REINFORCING STEEL	(BR-1)	LB.	750.00
511(B)	2310	EPOXY COATED REINFORCING STEEL	(BR-1)	LB.	459,510.00
514(A)	5210	PILES, FURNISHED (HP 10X42)	(BR-6)	L.F.	123.00
514(A)	5220	PILES, FURNISHED (HP 12X53)	(BR-6)	L.F.	123.00
514(B)	5310	PILES, DRIVEN (HP 10X42)		L.F.	56.00
514(B)	5320	PILES, DRIVEN (HP 12X53)		L.F.	56.00
514(L)	6300	PILE SPLICE H-PILE (NON-BIDDABLE)		EA.	1.00
515(A)	7200	WATER REPELLENT (VISUALLY INSPECTED)	(BR-1)	S.Y.	3,130.00
516(A)	8250	DRILLED SHAFTS 72" DIAMETER		L.F.	60.00
516(A)	8255	DRILLED SHAFTS 84" DIAMETER		L.F.	120.00
516(C)	8400	CROSSHOLE SONIC LOGGING	(BR-1)	EA.	6.00
517	9110	ELASTOMERIC COATING	(BR-1)	S.F.	1,480.00
518(B)	0300	SEALED EXPANSION JOINT	(BR-1)	L.F.	195.39
523(A)	3200	SEALER CRACK PREPARATION	(BR-1)	L.F.	200.00
523(B)	3300	SEALER RESIN	(BR-1)(BR-5)	GAL.	2.20
613(H)	6205	6" PERFORATED PIPE UNDERDRAIN ROUND	(BR-1)(BR-7)	L.F.	120.00
613(I)	6310	6" NON-PERF.PIPE UNDERDRAIN RND.	(BR-8)	L.F.	40.00

OKLAHOMA ONE-CALL SYSTEM:
IN ACCORDANCE WITH THE OKLAHOMA UNDERGROUND FACILITIES DAMAGE PREVENTION ACT, THE CONTRACTOR SHALL NOTIFY OKIE811 THREE BUSINESS DAYS PRIOR TO BEGINNING EXCAVATION AT OKIE811.ORG.

PHASE 4		OKLAHOMA COUNTY	
DESIGN		BRIDGE "A"	RAMP "A" AT I-35 & I-240 INTERCHANGE
DRAWN		SUMMARY OF PAY QUANTITIES (BRIDGE)	
CHECKED			
APPROVED			
SQUAD	POE		
		STATE JOB NO. 09032(08) SHEET NO. ABO1	

- (BR-1) PAYMENT FOR THIS ITEM WILL BE BASED ON PLAN QUANTITY. SEE THE 2019 OKLAHOMA STANDARD SPECIFICATIONS FOR HIGHWAY CONSTRUCTION - "PLAN QUANTITIES", SECTION 109.01.B.
- (BR-2) THE APPROACH SLABS CONTAIN AN ESTIMATED TOTAL OF 79 CY. OF CLASS AA CONCRETE AND 14,940 LBS. OF EPOXY COATED REINFORCING STEEL.
- (BR-3) THE FIXED BEARING ASSEMBLIES CONTAIN AN ESTIMATED TOTAL OF 890 LBS. OF WEATHERING STEEL.
- (BR-4) THE EXPANSION BEARING ASSEMBLIES CONTAIN AN ESTIMATED TOTAL OF 6,310 LBS. OF STAINLESS STEEL.
- (BR-5) PROVIDE AND INSTALL ELASTOMERIC PADS BETWEEN THE TOP SURFACE OF BEAMS AND THE BOTTOM SURFACE OF THE DECK SLAB. THE ELASTOMERIC PADS ARE TO BE OF THE SIZE AND SHAPE AS DETAILED IN THE PLANS AND LOCATED AT EACH BEAM ABOVE THE PIERS.
- (BR-6) STEEL PILES SHALL CONFORM TO AASHTO M270 (ASTM A709) GRADE 50.
- (BR-7) QUANTITY SHOWN FOR SEALER RESIN IS ESTIMATED AT 0.011 GALLONS PER FOOT OF CONSTRUCTION JOINT.
- (BR-8) THIS ITEM INCLUDES 88 FT. OF PERFORATED PIPE AND 352 CY. OF PIPE UNDERDRAIN COVER MATERIAL FOR THE ABUTMENTS.
- (BR-9) THIS ITEM INCLUDES 40 FT. OF NON-PERFORATED PIPE AND 260 CY. OF TRENCH UNDERDRAIN EXCAVATIONS AND 260 CY. OF STANDARD BEDDING MATERIAL FOR THE ABUTMENTS.
- (BR-10) ITEM "REMOVAL OF EXISTING BRIDGE STRUCTURE" CONSISTS OF THE REMOVAL AND DISPOSAL OF THE BRIDGE STRUCTURE IDENTIFIED ON GENERAL PLAN AND ELEVATION SHEETS. THE BRIDGE CONSISTS OF 35'-45'-56'-56'-45'-35' I-BEAM SPANS WITH 48'-0" CLEAR ROADWAY FOR EASTBOUND TRAFFIC AND A 48'-0" CLEAR ROADWAY FOR WESTBOUND TRAFFIC. INCLUDED WITH THE BRIDGE STRUCTURE ARE APPROACH SLABS AT BOTH ENDS OF THE BRIDGE. THE APPROACH SLABS, SUPERSTRUCTURE, AND SUBSTRUCTURE OF THE BRIDGE SHALL BE REMOVED AND DISPOSED IN ACCORDANCE WITH 619.04.B.(2) "STRUCTURES TO BECOME THE PROPERTY OF CONTRACTOR".
- (BR-11) THE EXISTING 32-W27X94, 32-W30X124 AND 32-W33X152 MAY REMAIN THE PROPERTY OF THE DEPARTMENT. THESE BEAMS SHALL BE REMOVED AND TRANSPORTED WITHOUT DAMAGE AND PLACED AT A DESIGNATED LOCATION WITHIN THE PROJECT LIMITS AS DIRECTED BY THE ENGINEER. IF THE RESIDENT ENGINEER DETERMINES THAT BEAMS ARE NOT AVAILABLE FOR REUSE, THESE BEAMS SHALL BECOME THE PROPERTY OF THE CONTRACTOR IN ACCORDANCE WITH 619.04.B.(2) "STRUCTURES TO BECOME THE PROPERTY OF CONTRACTOR".

I/P NO. 09032(08) 0201 BRIDGE "C"		PAY QUANTITIES			OKLAHOMA COUNTY
		60' - 100' - 100' - 60' P.C. BEAM SPANS. SKEW 0 38' CLEAR ROADWAY W/42" - FSHAPE PARAPET			
ITEM NO.		ITEM	UNIT	TOTAL	
501 (B)	1300	SUBSTRUCTURE EXCAVATION COMMON	(BR-1) C.Y.	90.00	
501 (G)	1800	CLSM BACKFILL	(BR-1) C.Y.	198.00	
503 (A)	4240	PRESTRESSED CONCRETE BEAMS (TYPE IV)	(BR-1) L.F.	1,593.34	
504 (A)	5200	APPROACH SLAB	(BR-1)(BR-2) S.Y.	218.80	
504 (B)	5300	SAW-CUT GROOVING	(BR-1) S.Y.	1,556.00	
504 (E)	5520	42" F-SHAPED PARAPET	(BR-1) L.F.	737.00	
506 (A)	7200	STRUCTURAL STEEL	(BR-1) LB.	1,540.00	
507 (A)	8210	WEATHERING STEEL FIXED BEARING ASSEMBLY	(BR-3) EA.	10.00	
507 (B)	8200	STAINLESS STEEL EXPANSION BEARING ASSEMBLY	(BR-4) EA.	30.00	
507 (C)	8400	ELASTOMERIC BEARING PADS	(BR-5) EA.	30.00	
509 (A)	0210	CLASS AA CONCRETE	(BR-1) C.Y.	396.30	
509 (B)	0320	CLASS A CONCRETE	(BR-1) C.Y.	330.80	
509 (D)	0510	CLASS C CONCRETE	C.Y.	2.00	
510 (C)	1450	SLOPE WALL (5")	S.Y.	853.00	
511 (A)	2210	REINFORCING STEEL	(BR-1) LB.	8,280.00	
511 (B)	2310	EPOXY COATED REINFORCING STEEL	(BR-1) LB.	167,120.00	
514 (A)	5210	PILES, FURNISHED (HP 10X42)	(BR-6) L.F.	518.00	
514 (B)	5310	PILES, DRIVEN (HP 10X42)	L.F.	518.00	
514 (L)	6300	PILE SPLICE, H-PILE (NON-BIDDABLE)	EA.	1.00	
515 (A)	7200	WATER REPELLENT (VISUALLY INSPECTED)	(BR-1) S.Y.	1,723.00	
516 (A)	8250	DRILLED SHAFTS 72" DIAMETER	L.F.	142.00	
516 (C)	8400	CROSSHOLE SONIC LOGGING	EA.	1.00	
517	9110	ELASTOMERIC COATING	S.F.	624.00	
523 (A)	3200	SEALER CRACK PREPARATION	(BR-1) L.F.	228.00	
523 (B)	3300	SEALER RESIN	(BR-1)(BR-7) GAL.	3.00	
613 (H)	6205	6" PERFORATED PIPE UNDERDRAIN ROUND	(BR-8) L.F.	210.00	
613 (I)	6310	6" NON-PERF. PIPE UNDERDRAIN ROUND	(BR-9) L.F.	80.00	
619 (D)	6700	REMOVAL OF EXISTING BRIDGE STRUCTURE	(BR-10)(BR-11) LSUM.	1.00	

3/1/2024 2:43:32 PM H:\PROJECTS\2789_CrossRoads_Phase 4\Bridges\Drawings\Phase 4\Bridges\Bridges\0903208 P4 Bridge C Gen Notes.dgn

DESIGN							
DRAWN							
CHECKED							
APPROVED							
SQUAD		POE					

PHASE 4
OKLAHOMA COUNTY

BRIDGE "C" RAMP "1" OVER 1-35

SUMMARY OF PAY QUANTITIES

(BRIDGE)

STATE JOB NO. 09032(08) SHEET NO. AB03

(BR-1) PAYMENT FOR THIS ITEM WILL BE BASED ON PLAN QUANTITIES. SEE SECTION 109.01.B OF THE STANDARD SPECIFICATIONS.

(BR-2) THE CONTRACTOR MAY PLACE CONCRETE AGAINST THE LIMITS OF EXCAVATION IF THE MATERIAL IS EXCAVATED TO THE NEAT LINES OF THE ABUTMENT AND APPROVED BY THE ENGINEER. IF THE CONTRACTOR PLACES CONCRETE AGAINST THE SOIL, THE DEPARTMENT WILL PAY FOR SUBSTRUCTURE EXCAVATION COMMON IN ACCORDANCE WITH THE DIAGRAMS SHOWN ON THE "ABUTMENT EXCAVATION AND UNDERDRAIN DETAILS" SHEET.

(BR-3) THE APPROACH SLABS CONTAIN AN ESTIMATED TOTAL OF 112.9 CY. OF CLASS AA CONCRETE AND 21,520 LBS. OF EPOXY COATED REINFORCING STEEL. THE DEPARTMENT INCLUDES THE COST OF POLYETHYLENE SHEETING, LOAD TRANSFER UNITS, CONCRETE, REINFORCING STEEL (INCLUDING FS2 #5 AND FS6 #5 BARS), BACKER ROD, RAPID CURE JOINT SEALANT, AND POLYSTYRENE IN THE CONTRACT UNIT PRICE OF "APPROACH SLAB".

(BR-4) THE FIXED BEARING ASSEMBLIES CONTAIN AN ESTIMATED TOTAL OF 1,060 LBS. OF WEATHERING STEEL. THE DEPARTMENT INCLUDES THE COSTS OF ANCHOR BARS, ANCHOR PLATES, BOLTS, NUTS AND WASHERS IN THE CONTRACT UNIT PRICE OF "WEATHERING STEEL FIXED BEARING ASSEMBLY".

(BR-5) THE EXPANSION BEARING ASSEMBLIES CONTAIN AN ESTIMATED TOTAL OF 7,590 LBS. OF STAINLESS STEEL. THE DEPARTMENT INCLUDES THE COSTS OF ELASTOMERIC PADS, ANCHOR BOLTS, ANCHOR PLATES, BOLTS, NUTS AND WASHERS IN THE CONTRACT UNIT PRICE OF "STAINLESS STEEL EXPANSION BEARING ASSEMBLY".

(BR-6) PROVIDE AND INSTALL ELASTOMERIC PADS BETWEEN THE TOP SURFACE OF BEAMS AND THE BOTTOM SURFACE OF THE DECK SLAB. THE ELASTOMERIC PADS ARE TO BE OF THE SIZE AND SHAPE AS DETAILED IN THE PLANS AND LOCATED AT EACH BEAM ABOVE THE PIERS. INCLUDE ALL COSTS ASSOCIATED WITH PROVIDING AND INSTALLING THE ELASTOMERIC PADS ABOVE THE BEAMS, INCLUDING ALL MATERIAL, LABOR, EQUIPMENT, AND INCIDENTALS NECESSARY TO COMPLETE THE WORK AS SHOWN IN THE PLANS, IN THE PRICE BID PER EACH OF "ELASTOMERIC BEARING PADS".

(BR-7) STEEL PILES SHALL CONFORM TO AASHTO M270 (ASTM A709) GRADE 50. PAYMENT TO THE CONTRACTOR WILL BE BASED ON PLAN QUANTITIES UNLESS ADDITIONAL PILING LENGTH IS REQUIRED. ADDITIONAL PILES FURNISHED, AS AUTHORIZED BY THE ENGINEER WILL BE PAID AT THE CONTRACT UNIT PRICE.

(BR-8) REFER TO DRILLED SHAFT FOUNDATION SPECIAL PROVISION 516-3(a-r) 09 PROVIDED IN THE CONTRACT DOCUMENTS.

(BR-9) QUANTITY SHOWN FOR SEALER RESIN IS ESTIMATED AT 0.011 GALLONS PER FOOT OF CONSTRUCTION JOINT.

(BR-10) THIS ITEM INCLUDES 114 FT. OF PERFORATED PIPE AND 456 C.Y. OF PIPE UNDERDRAIN COVER MATERIAL FOR THE ABUTMENTS.

J/P NO. 09032(08)		PAY QUANTITIES		OKLAHOMA COUNTY	
0202 BRIDGE "D"		60' - 100' - 100' - 60' P.C. BEAM SPANS		SKEW 0 68' AND 56' CLEAR ROADWAY W/42" F-SHAPE PARAPET	
ITEM NO.		ITEM	UNIT	TOTAL	
501(B)	1300	SUBSTRUCTURE EXCAVATION COMMON (BR-1)(BR-2)	C.Y.	80.00	
501(G)	1800	CLSM BACKFILL (BR-1)	C.Y.	252.00	
503(A)	4240	PRESTRESSED CONCRETE BEAMS (TYPE IV) (BR-1)	L.F.	1,912.00	
504(A)	5200	APPROACH SLAB (BR-1)(BR-3)	S.Y.	312.00	
504(B)	5300	SAW-CUT GROOVING (BR-1)	S.Y.	2,294.00	
504(E)	5500	CONCRETE PARAPET (BR-1)	L.F.	368.50	
504(E)	5520	42" F-SHAPED PARAPET (BR-1)	L.F.	368.50	
506(A)	7200	STRUCTURAL STEEL (BR-1)	LB.	2,390.00	
507(A)	8210	WEATHERING STEEL FIXED BEARING ASSEMBLY (BR-4)	EA.	12.00	
507(B)	8300	STAINLESS STEEL EXPANSION BEARING ASSEMBLY (BR-5)	EA.	36.00	
507(C)	8400	ELASTOMERIC BEARING PADS (BR-6)	EA.	36.00	
509(A)	0210	CLASS AA CONCRETE (BR-1)	C.Y.	568.00	
509(B)	0320	CLASS A CONCRETE (BR-1)	C.Y.	381.50	
509(D)	0510	CLASS C CONCRETE	C.Y.	2.00	
510(C)	1450	SLOPE WALL (5")	S.Y.	652.00	
511(A)	2210	REINFORCING STEEL (BR-1)	LB.	8,710.00	
511(B)	2310	EPOXY COATED REINFORCING STEEL (BR-1)	LB.	202,610.00	
514(A)	5210	PILES, FURNISHED (HP 10X42) (BR-7)	L.F.	522.00	
514(B)	5310	PILES, DRIVEN (HP 10X42)	L.F.	522.00	
514(L)	6300	PILE SPLICE, H-PILE (NON-BIDABLE)	EA.	1.00	
515(A)	7200	WATER REPELLENT (VISUALLY INSPECTED) (BR-1)	S.Y.	1,338.00	
516(A)	8250	DRILLED SHAFTS 72" DIAMETER (BR-8)	L.F.	168.00	
516(C)	8400	CROSSHOLE SONIC LOGGING	EA.	2.00	
517	9110	ELASTOMERIC COATING	S.F.	993.00	
523(A)	3200	SEALER CRACK PREPARATION (BR-1)	L.F.	342.00	
523(B)	3300	SEALER RESIN (BR-1)(BR-9)	GAL.	4.00	
613(H)	6205	6" PERFORATED PIPE UNDERDRAIN ROUND (BR-10)	L.F.	228.00	

3/1/2024 2:25:14 PM H:\PROJECTS\2789_CrossRoads_Phase 4\Bridges\Drawings\Ph4 Bridges\Bridg D\0903208 P4 Bridge D Gen Notes.dgn

PHASE 4 OKLAHOMA COUNTY

BRIDGE "D" I-240 OVER I-35

DESIGN	
DRAWN	
CHECKED	
APPROVED	
SQUAD	POE

SUMMARY OF PAY QUANTITIES
(BRIDGE)

STATE JOB NO. 09032(08) SHEET NO. AB05

**90% PLAN
SUBMITTAL**
2/29/2024

- (BR-1) PAYMENT FOR THIS ITEM WILL BE BASED ON PLAN QUANTITIES. SEE THE 2019 OKLAHOMA STANDARD SPECIFICATIONS FOR HIGHWAY CONSTRUCTION - "PLAN QUANTITIES". SECTION 109.01.B.
- (BR-2) THE APPROACH SLABS CONTAIN AN ESTIMATED TOTAL OF 76.80 C.Y. OF CLASS AA CONCRETE AND 14,660.00 LBS. OF EPOXY COATED REINFORCING STEEL.
- (BR-3) PRICE BID FOR THESE ITEMS SHALL INCLUDE THE COST OF INSTALLING FORM LINERS AND STAINING SURFACES AS STATED IN THE SPECIAL PROVISION "CONCRETE, MISC.: AESTHETIC TREATMENTS".
- (BR-4) THIS ITEM INLCUDES 68 FT. OF PERFORATED PIPE AND 240 C.Y. OF PIPE UNDERDRAIN COVER MATERIAL FOR THE ABUTMENTS.
- (BR-5) THIS ITEM INCLUDES 40 FT. OF NON-PERFORATED PIPE AND 256 CUBIC YARDS OF TRENCH UNDERDRAIN FOR THE ABUTMENTS.

J/P NO. 09032(08) 0203 BRIDGE "L"		PAY QUANTITIES		OKLAHOMA COUNTY	
RAMP "L" OVER RAMP "A" 125'-163'-125' P.C. BOX GIRDER SPANS 29'-0" CLEAR ROADWAY WITH 42" F-SHAPED PARAPETS					
ITEM NO.		ITEM		UNIT	TOTAL
501(B)	1300	SUBSTRUCTURE EXCAVATION COMMON	(BR-1)	C.Y.	606.00
501(C)	1400	SUBSTRUCTURE EXCAVAION ROCK	(BR-1)	C.Y.	244.00
501(G)	1800	CLSM BACKFILL	(BR-1)	C.Y.	620.00
504(A)	5200	APPROACH SLAB	(BR-1)(BR-2)	S.Y.	212.70
504(B)	5300	SAW-CUT GROOVING	(BR-1)	S.Y.	1,331.00
504(E)	5520	42" F-SHAPED PARAPET	(BR-1)(BR-3)	L.F.	947.30
506(A)	7230	STRUCTURAL STEEL (A36)	(BR-1)	LB.	792.00
507(C)	8400	ELASTOMERIC BEARING PAD	(BR-1)	EA.	8.00
509(A)	0210	CLASS AA CONCRETE	(BR-1)	C.Y.	172.90
509(B)	0320	CLASS A CONCRETE	(BR-1)	C.Y.	47.60
509(E)	0600	CLASS P CONCRETE	(BR-1)	C.Y.	1,029.00
510(C)	1450	SLOPE WALL (5")		S.Y.	262.00
511(A)	2210	REINFORCING STEEL	(BR-1)	LB.	5,956.00
511(B)	2310	EPOXY COATED REINFORCING STEEL	(BR-1)	LB.	233,815.00
515(A)	7200	WATER REPELLENT (VISUALLY INSPECTED)	(BR-1)	S.Y.	2,762.00
516(A)	8215	DRILLED SHAFTS 30" DIAMETER		L.F.	80.00
516(A)	8225	DRILLED SHAFTS 42" DIAMETER		L.F.	160.00
516(A)	8255	DRILLED SHAFTS 84" DIAMETER		L.F.	22.00
516(C)	8400	CROSSHOLE SONIC LOGGING		EA.	3.00
613(H)	6205	6" PERFORATED PIPE UNDERDRAIN ROUND	(BR-1)(BR-4)	L.F.	102.70
613(I)	6310	6" NON-PERF.PIPE UNDERDRAIN RND.	(BR-5)	L.F.	60.00

3/1/2024 10:35:17 AM H:\PROJECTS\2789_CrossRoads_Phase 4\Bridges\Drawings\Ph4 Bridges\Bridges L\0903208 P4 Br L_PONOTES.dgn

DESIGN		PHASE 4	OKLAHOMA COUNTY
DRAWN		BRIDGE "L"	RAMP "L" OVER RAMP "A"
CHECKED		SUMMARY OF PAY QUANTITIES (BRIDGE)	
APPROVED			
SQUAD	POE	STATE JOB NO. <u>09032(08)</u> SHEET NO. <u>AB07</u>	

GENERAL BRIDGE NOTES

SPECIFICATIONS:

ALL CONSTRUCTION AND MATERIALS SHALL BE IN ACCORDANCE WITH THE 2019 OKLAHOMA STANDARD SPECIFICATIONS FOR HIGHWAY CONSTRUCTION AND SPECIAL PROVISIONS.

CROSSHOLE SONIC LOGGING (TUBES AND TESTING):

INSTALL ACCESS TUBES AT ALL DRILLED SHAFT LOCATIONS AND PERFORM NONDESTRUCTIVE CROSSHOLE SONIC LOGGING (CSL) TESTING AS DIRECTED. THE ENGINEER SHALL DETERMINE THE LOCATION AND NEED FOR TESTING. CSL TESTING SHALL BE PERFORMED IN ACCORDANCE WITH SECTION 516.04.C.9c OF THE STANDARD SPECIFICATION.

CROSSHOLE SONIC LOGGING (TUBES AND TESTING):

INSTALL ACCESS TUBES AT ALL DRILLED SHAFT LOCATIONS AND PERFORM NONDESTRUCTIVE CROSSHOLE SONIC LOGGING (CSL) TESTING AS DIRECTED. THE ENGINEER SHALL DETERMINE THE LOCATION AND NEED FOR TESTING. CSL TESTING SHALL BE PERFORMED IN ACCORDANCE WITH SECTION 516.04.C.9c OF THE STANDARD SPECIFICATION.

STAY-IN-PLACE FORMS:

THE CONTRACTOR MAY USE STAY-IN-PLACE STEEL DECK FORMS INSIDE THE BOX GIRDERS MEETING THE REQUIREMENTS OF SECTION 504 OF THE STANDARD SPECIFICATIONS.

TOP SLAB REINFORCING STEEL:

ALL LONGITUDINAL TOP REINFORCING STEEL SHALL BE SUPPORTED ON APPROVED CONTINUOUS METAL HIGH CHAIRS (CHC) SPACED AT 4'-0" MAXIMUM ON CENTERS. THE BOTTOM LAYER OF REINFORCING STEEL SHALL BE SUPPORTED ON APPROVED METAL SLAB BOLSTERS (SB) SPACED AT 4'-0" MAXIMUM ON CENTERS. SPECIAL BAR SUPPORTS MAY BE REQUIRED IF STAY-IN-PLACE FORMS ARE USED.

BOTTOM SLAB REINFORCING STEEL:

THE BOTTOM LAYER OF TRANSVERSE REINFORCING STEEL SHALL BE SUPPORTED ON APPROVED METAL SLAB BOLSTERS (SB) SPACED AT 4'-0" MAXIMUM ON CENTERS.

CONCRETE:

CONCRETE FOOTINGS FOR PIER AND ABUTMENT SHALL BE CLASS A.
 F'C = 3000 PSI AT 28 DAYS
 CONCRETE FOR ABUTMENT WINGS AND PIER COLUMNS SHALL BE CLASS AA.
 F'C = 4000 PSI AT 28 DAYS
 CONCRETE FOR SUPERSTRUCTURES, ABUTMENT STEMS, AND END DIAPHRAGMS SHALL BE CLASS P.
 F'C = 4000 PSI AT 28 DAYS
 F'CI = 3600 PSI AT TIME OF PRESTRESSING

PRESTRESSING:

A) GENERAL: THE TYPE OF PRESTRESSING STEEL ASSUMED FOR DESIGN WAS 270 KSI UNCOATED SEVEN-WIRE LOW-RELAXATION STRANDS CONFORMING TO THE REQUIREMENTS OF AASHTO M203 (ASTM A416) SUPPLEMENT 1. DESIGN IS BASED ON A FRICTION FACTOR, $M = 0.25$, A WOBBLE COEFFICIENT, $K = 0.0002$, AN EQUIVALENT ANCHOR SET OF 3/8", AND LONG TERM PRESTRESSING LOSSES DUE TO SHRINKAGE, ELASTIC SHORTENING, CREEP AND STRAND RELAXATION = 32 KSI.

IF A PRESTRESSING SYSTEM IS PROPOSED THAT PRODUCES DIFFERENT VALUES THAN THOSE ASSUMED ABOVE, THE CONTRACTOR SHALL PROVIDE NECESSARY DESIGN CALCULATIONS TO MODIFY PJACK AS SHOWN ON THESE PLANS IN ORDER TO SATISFY THE ALLOWABLE STRESSES.

BAR REINFORCEMENT INTERFERING WITH THE PRESTRESSING TENDON ALIGNMENT SHALL BE ADJUSTED, AS APPROVED BY THE ENGINEER.

THE WORKING DRAWINGS SHALL INCLUDE ANY ADDITIONS OR REARRANGEMENT OF REINFORCING STEEL FROM THAT SHOWN ON THE PLANS.

B) DISTRIBUTION OF PRESTRESSING FORCE: PRESTRESSING FORCES, PJACK, SHALL BE APPLIED TO BOTH ENDS OF THE PRESTRESSING STEEL. FORCES SHALL BE DISTRIBUTED WITH AN APPROXIMATELY EQUAL AMOUNT IN EACH GIRDER AND SHALL BE PLACED SYMMETRICALLY ABOUT THE CENTERLINE OF THE STRUCTURE. THE PRESTRESSING FORCE MAY VARY ± 5% FROM THE THEORETICAL EQUAL FORCE PER GIRDER PROVIDED THE TOTAL PJACK IS OBTAINED.

C) ANCHORAGES: ANCHORAGE DEVICES SHALL MEET THE REQUIREMENTS OF SUBSECTION 517.02(G) OF THE STANDARD SPECIFICATIONS. IF BASIC BEARING PLATES ARE PROPOSED, THE CONTRACTOR SHALL SUBMIT DESIGN CALCULATIONS TO SUPPORT THE SIZE AND THICKNESS OF THE BEARING PLATE AND ANY LOCAL ZONE REINFORCEMENT (REGION IMMEDIATELY AHEAD OF THE ANCHORAGE DEVICE).

CONCRETE SURFACE FINISH:

ALL EXPOSED SURFACES OF PIERS, ABUTMENTS, PARAPETS (OUTSIDE FACE) AND SUPERSTRUCTURE (EXCEPT DRIVING SURFACE) SHALL RECEIVE A CLASS 6 MORTAR FINISH IN ACCORDANCE WITH SUBSECTION 509.04(G)(6) OF THE SPECIFICATIONS. THE MORTAR FINISH SHALL CONFORM TO FEDERAL STANDARD COLOR NO. 33531. SAMPLE PANELS MEASURING 12" X 18" SHOWING THE CONCRETE FINISH FOR BOTH SMOOTH AND TEXTURED SURFACES SHALL BE SUBMITTED TO THE BRIDGE ENGINEER FOR APPROVAL. THE APPROVED PANELS SHALL BE USED AS STANDARDS THROUGHOUT THE PROJECT. THE TOP AND INSIDE FACE OF THE PARAPETS SHALL BE FINISHED IN ACCORDANCE WITH SUBSECTION 504.04(I)(3) OF THE STANDARD SPECIFICATIONS. ALL COST OF CONCRETE SURFACE FINISH SHALL BE INCLUDED IN OTHER ITEMS OF WORK.

DRILLED SHAFT CONSTRUCTION:

DUE TO THE VERY HARD ROCK ENCOUNTERED AT THIS SITE, DRILLED SHAFT EXCAVATIONS WILL REQUIRE SPECIALIZED ROCK DRILLING EQUIPMENT. THE CONTRACTOR IS RESPONSIBLE FOR BECOMING FAMILIAR WITH THE EXISTING SUBSURFACE CONDITIONS AND THEIR IMPLICATIONS ON THE DRILLING PROCESSES PRIOR TO BEGINNING WORK.

PENETRATING WATER REPELLANT SURFACE TREATMENT:

PENETRATING WATER REPELLANT SURFACE TREATMENT SHALL BE APPLIED TO THE INSIDE AND TOP FACE OF THE PARAPETS ON THE APPROACH SLABS AND THE ENTIRE EXPOSED AREA OF THE SUPERSTRUCTURE AND PARAPETS (EXCEPT THE DRIVING SURFACE) IN ACCORDANCE WITH SECTION 515 OF THE STANDARD SPECIFICATIONS.

ELASTOMERIC BEARING PAD:

PROVIDE AND INSTALL ELASTOMERIC BEARING PADS OF THE SIZE, SHAPE AND LOCATION AS DETAILED IN THE PLANS. INCLUDE ALL COSTS ASSOCIATED WITH PROVIDING AND INSTALLING THE ELASTOMERIC PADS WITH A36 STEEL LAMINATES INCLUDING ALL MATERIAL, LABOR, EQUIPMENT, AND INCIDENTALS NECESSARY TO COMPLETE THE WORK AS SHOWN IN THE PLANS, IN THE PRICE BID PER EACH OF "ELASTOMERIC BEARING PAD".

OKLAHOMA OKIE811 SYSTEM:

IN ACCORDANCE WITH THE OKLAHOMA UNDERGROUND FACILITIES DAMAGE PREVENTION ACT, THE CONTRACTOR SHALL NOTIFY OKIE811 THREE BUSINESS DAYS PRIOR TO BEGINNING EXCAVATION AT OKIE811.ORG.

3/1/2024 10:35:19 AM H:\PROJECTS\2789_CrossRoads_Phase 4\Bridges\Drawings\Ph4 Bridges\Bridges L\0903208 P4 Br L_PONOTES.dgn

DESIGN			PHASE 4	OKLAHOMA COUNTY
DRAWN			BRIDGE "L"	RAMP "L" OVER RAMP "A"
CHECKED			GENERAL NOTES (BRIDGE)	
APPROVED				
SQUAD		POE		
			STATE JOB NO. 09032(08)	SHEET NO. AB08

90% PLAN
SUBMITTAL

3/11/2024

GENERAL CONSTRUCTION NOTES

IN ACCORDANCE WITH THE OKLAHOMA UNDERGROUND FACILITIES DAMAGE PREVENTION ACT THE CONTRACTOR SHALL NOTIFY THE OKLAHOMA ONE-CALL SYSTEM, INC. 48 HOURS PRIOR TO BEGINNING EXCAVATION. OKLAHOMA ONE-CALL SYSTEM, INC. "CALL OKIE" 1-800-522-6543 OR 811.

THIS PROJECT SHALL BE CONSTRUCTED WITHOUT CLOSING THE EXISTING ROAD TO LOCAL AND THROUGH TRAFFIC. SEE STANDARD SPECIFICATIONS FOR MAINTENANCE OF LOCAL AND THROUGH TRAFFIC.

MAINTENANCE OF THROUGH TRAFFIC INCLUDES THE MAINTENANCE OF THE EXISTING ROAD IN CLOSE PROXIMITY TO THE NEW CONSTRUCTION AS SHOWN ON THE PLANS.

FOR PROJECTS THAT INCLUDE WIDENING AND/OR RESURFACING, THE CONTRACTOR SHALL SCHEDULE OPERATIONS TO MINIMIZE POTENTIAL DROP-OFF HAZARDS AND SHALL SUBMIT A SEQUENCE OF CONSTRUCTION OPERATIONS TO THE RESIDENT ENGINEER FOR APPROVAL BEFORE OPERATIONS BEGIN. ANY PORTION OF THE CONSTRUCTION OPERATIONS, SUCH AS SUPERPAVE LAYING OPERATIONS, EXCAVATION FOR PAVEMENT WIDENING, OR EXTENSION OF ROADWAY STRUCTURES, SHALL BE LIMITED TO ONE SIDE AT A TIME, AND THE PROCEDURES OUTLINED IN THE PAVEMENT DROP-OFF TREATMENT STANDARD PDT-1 (LATEST REVISION) SHALL BE IMPLEMENTED. ONLY THAT AMOUNT OF OPEN TRENCH WILL BE ALLOWED THAT CAN BE SURFACED IN 1 (ONE) DAY'S TIME WITHOUT APPROVAL BY THE ENGINEER. LIGHTS, SIGNS AND BARRICADES SHALL BE MOVED AS WORK PROGRESSES.

ALL TREES, BRUSH, AND OTHER DEBRIS THAT MIGHT INTERFERE WITH THE FLOW OF WATER SHALL BE CLEANED OUT TO THE RIGHT-OF-WAY LINE, AT EACH STRUCTURE AND BRIDGE, IN A MANNER APPROVED BY THE ENGINEER. ALL COST TO BE INCLUDED IN OTHER ITEMS OF WORK.

ALL FLOWLINES THAT ARE TO BE FILLED SHALL BE THOROUGHLY TAMPED BEFORE CONSTRUCTION OR EXTENSION OF DRAINAGE STRUCTURES. ALL COST TO BE INCLUDED IN OTHER ITEMS OF WORK.

IN ORDER TO ALLEVIATE DUST CONDITIONS DURING GRADING OPERATIONS AND BEFORE PAVEMENT WORK IS COMPLETED, THE CONTRACTOR SHALL SPRINKLE GRADING AT INTERVALS APPROVED BY THE ENGINEER. ALL COST TO BE INCLUDED IN OTHER ITEMS OF WORK.

THE CONTRACTOR SHALL NOT WASTE ANY EXCESS EXCAVATION UNTIL ALL PLANNED EMBANKMENTS AND BACKFILLS ARE COMPLETED. EXCESS UNCLASSIFIED EXCAVATION MATERIAL DETERMINED BY THE ENGINEER TO BE SUITABLE FOR BACKFILL SHALL BE USED TO REDUCE ANY UNCLASSIFIED BORROW NEEDED. COST OF SECOND HANDLING SHALL BE INCLUDED IN OTHER ITEMS OF WORK. ANY REMAINING EXCESS EXCAVATION SHALL BECOME THE PROPERTY OF THE CONTRACTOR AND BE DISPOSED OF IN A MANNER APPROVED BY THE ENGINEER.

THE CONTRACTOR SHALL KEEP THE OPEN TRENCH DRAINED. COST TO BE INCLUDED IN OTHER ITEMS OF WORK.

VEGETATIVE MULCHING: THE VEGETATIVE MULCH SHALL BE ANCHORED IN ACCORDANCE WITH THE "MULCHING-TILLER METHOD", AS SPECIFIED IN 233.04B(2) OF THE STANDARD SPECIFICATIONS.

AREAS ON WHICH SALVAGED TOPSOIL IS TO BE REPLACED SHALL HAVE 18-46-0 FERTILIZER APPLIED, AT THE RATE OF 150 POUNDS PER ACRE, JUST PRIOR TO THE REPLACEMENT OF SALVAGED TOPSOIL.

AT THE BEGINNING OF TURFING OPERATIONS, ANY AREAS INCLUDED IN PLANNED QUANTITIES THAT HAVE GROWN A SATISFACTORY VOLUNTEER TURF OF PERENNIAL GRASS, AS DETERMINED BY THE ENGINEER, SHALL BE FERTILIZED AND WATERED AS CALLED FOR ON THE PLANS, BUT SHALL NOT BE SEEDDED, SODDED, OR SPRIGGED.

PIPE UNDERDRAIN QUANTITIES ESTIMATED ONLY. LOCATION, IF AND WHERE REQUIRED, TO BE DETERMINED BY THE ENGINEER.

T.B.S.C. SURFACES SHALL BE SPRINKLED WITH WATER AND ROLLED WITH A PNEUMATIC ROLLER IN A MANNER APPROVED BY THE ENGINEER.

THE ENGINEER SHALL CHECK GRADES AT RAMP TERMINALS, AND MAKE ANY ADJUSTMENTS OF THE GRADES AND SUPERELEVATIONS, WHICH ARE REQUIRED TO OBTAIN SMOOTH PROFILES FOR BOTH EDGES OF THE RAMP PAVEMENT. CROSS SLOPE BREAKOVER SHALL NOT EXCEED 5%(FIVE PERCENT).

ONLY THE SILICONE SEALANT OPTIONS, FROM STANDARD LECS-5, WILL BE ALLOWED ON THIS PROJECT.

PRIOR TO FINAL ACCEPTANCE, ALL EXPOSED CURB SURFACES SHALL BE CLEANED OF ALL DISCOLORATION SUCH AS ASPHALT STAIN, TIRE MARKS, OR OTHER DISFIGUREMENT.

EXCESS ASPHALT AT JOINTS AND CRACKS IN EXISTING PAVEMENT SHALL BE REMOVED FLUSH TO TOP OF PAVING IN A MANNER APPROVED BY THE ENGINEER.

ALL FEATURES OF THIS PROJECT INCLUDING, BUT NOT LIMITED TO, PATHS, SIDEWALKS, CURB RAMPS, AND CROSSWALK MARKINGS WILL COMPLY WITH PUBLIC RIGHTS-OF-WAY ACCESSIBILITY GUIDELINES (PROWAG), PUBLISHED JULY 26, 2011. WHERE SPECIAL LIMITATIONS OF EXISTING FEATURES WITHIN THE LIMITS OF THE PROJECT PREVENT FULL COMPLIANCE WITH PROWAG, THE CONTRACTOR WILL IMMEDIATELY NOTIFY THE ENGINEER UPON DISCOVERY OF SUCH FEATURES. THE CONTRACTOR WILL NOT PROCEED WITH ANY OF THE WORK, WHICH IS NOT IN FULL COMPLIANCE WITH PROWAG, WITHOUT PROIR WRITTEN APPROVAL FROM THE ENGINEER. ANY WORK WHICH IS NOT PERFORMED WITHIN THE GUIDELINES OF PROWAG FOR WHICH THE CONTRACTOR DOES NOT HAVE WRITTEN APPROVAL WILL BE CORRECTED AT THE CONTRACTOR'S EXPENSE.

CONSTRUCTION NOTES

ALL WORK AND/OR MATERIALS NOT CLASSIFIED AS A "CONTRACT PAY ITEM" SHALL BE CONSIDERED INCIDENTAL AND THE COST THEREOF SHALL BE INCLUDED IN THE UNIT PRICE BID FOR ITEMS WHICH ARE CLASSIFIED FOR PAYMENT.

(CAUTION) THE LOCATION OF ALL UTILITIES AS SHOWN ARE APPROXIMATE. DUE TO RELOCATIONS PLANNED OR PRESENTLY UNDER CONSTRUCTION THERE ARE SOME UTILITIES THAT WILL BE RELOCATED AND NOT SHOWN ON THESE PLANS. THE CONTRACTOR SHALL BE RESPONSIBLE FOR ANY DAMAGE TO ALL UTILITIES.

THE CONTRACTOR SHALL BE RESPONSIBLE FOR ANY DAMAGE HE MAY INFLECT TO THE EXISTING UNDERGROUND UTILITIES WITHIN THE PROJECT AREA AS A RESULT OF HIS DIGGING, TRENCHING, BORING, ETC.. PRIOR TO DIGGING NEAR THE UTILITIES, THE CONTRACTOR SHALL CALL FOR A LIST OF ALL UNDER GROUND FACILITIES REGISTERED IN THE AREA OF CONSTRUCTION LISTED WITH THE FOLLOWING AGENCIES:

THE OKIE NOTIFICATION CENTER (405) 840-5021 OR 1-800-522-6543

THE OWNERS OF UTILITIES LOCATED WITHIN THE LIMITS OF THIS PROJECT ARE:

OG&E	ODOT	THE CITY OF OKLAHOMA CITY
321 N. HARVEY	200 N.E. 21ST STREET	420 W. MAIN ST., SUITE 500
OKLA. CITY, OK 73102	OKLA. CITY, OK 73105	OKLA. CITY, OK 73102
(405)272-1010	(405)521-2661	(405)297-3548
ONG	AT&T	INDIAN NATIONS FIBER OPTICS
401 N. HARVEY	7001 N.W. 23RD ST.	124 WEST VINITA
OKLA. CITY, OK 73102	OKLA. CITY, OK 73008	SULPHUR, OK 73086
(405)551-4000	(405)291-3229	(580)622-4050

DEPTH & LOCATION OF EXISTING UTILITIES SHALL BE FIELD VERIFIED BY THE CONTRACTOR PRIOR TO CONSTRUCTION.

ALL EXISTING MANHOLES, VALVES, FIRE HYDRANTS AND METERS, WHICH ARE NOT BEING RELOCATED OR REMOVED, SHALL BE RESET TO PROPOSED CONDITIONS. ALL ITEMS THAT ARE TO BE REMOVED AND/OR RESET SHALL BE HANDLED WITH CARE. THE CONTRACTOR SHALL BE RESPONSIBLE FOR ANY DAMAGE OCCURRING DURING THESE OPERATIONS.

IN THE EVENT THE EXISTING SECTION LINE ROADS OR PUBLIC ROAD ARE IN ANY WAY DISTURBED AS A RESULT OF THE CONTRACTORS EFFORTS, IT SHALL BE THE RESPONSIBILITY OF SAID CONTRACTOR TO RETURN THE AREA TO ITS ORIGINAL CONDITION WITH NO ADDITIONAL COMPENSATION AS DIRECTED AND TO THE SATISFACTION OF THE ENGINEER.

A CONTRACTOR'S PROGRESS SCHEDULE SHALL BE PREPARED IN ACCORDANCE WITH SECTION 108.03 OF THE 2019 STANDARD SPECIFICATIONS FOR HIGHWAY CONSTRUCTION.

TEMPORARY EARTH RETAINAGE (SHEETING AND SHORING) SHALL BE THE RESPONSIBILITY OF THE CONTRACTOR AND SHALL BE DESIGNED BY A REGISTERED PROFESSIONAL ENGINEER IN THE STATE OF OKLAHOMA. DESIGN CALCULATIONS AND DRAWINGS SHALL BE SUBMITTED TO ODOT BRIDGE DIVISION FOR APPROVAL, PRIOR TO CONSTRUCTION. THE LIMITS OF THE SHEETING AND SHORING ARE TO BE DETERMINED BY THE CONTRACTOR. SEE SECTION 502.04.D OF THE 2019 STANDARD SPECIFICATIONS.

THE CONTRACTOR IS RESPONSIBLE FOR THE PROMPT REPLACEMENT AND/OR REPAIR OF ALL TRAFFIC CONTROL DEVICES AND APPURTENANCES DAMAGED OR DISTURBED DUE TO CONSTRUCTION.

A WORK ZONE PERMIT MUST BE OBTAINED FROM THE TRAFFIC MANAGEMENT DIVISION AT LEAST TWO (2) WORKING DAYS PRIOR TO THE START OF WORK AND/OR PLACING OR REMOVING ANY BARRICADES OR MODIFYING EXISTING TRAFFIC CONTROL DEVICES. CALL (405) 297-2531 TO OBTAIN AN APPLICATION.

THE CONTRACTOR IS RESPONSIBLE FOR THE REMOVAL OF ALL PAVEMENT MARKINGS THAT WILL BE IN CONFLICT WITH THE PROPOSED WORK.

AT ANY JOINTS IN A CONCRETE STRUCTURE, THE CENTER OF THE FIRST REINFORCING BAR PARALLEL TO THAT JOINT SHALL BE A MAXIMUM OF TWO INCHES FROM THE EDGE OF THE CONCRETE.

REMOVED MATERIAL TO BECOME THE PROPERTY OF THE CONTRACTOR AND IT SHALL BE DISPOSED OF IN A MANNER APPROVED BY THE ENGINEER.

ALL BROKEN CONCRETE INCLUDING OLD SIGN FOOTINGS WITH STUBS, WASTE MATERIAL AND DEBRIS SHALL BECOME THE PROPERTY OF THE CONTRACTOR AND SHALL BE REMOVED FROM THE LIMITS OF THE PROJECT AND DISPOSED OF IN AN AREA APPROVED BY THE ENGINEER. NO PAYMENT SHALL BE MADE FOR THE DISPOSAL OF THIS MATERIAL.

EXISTING GRADE LINES AND CROSS SLOPES SHALL BE FIELD VERIFIED. MODIFICATIONS TO THE GRADE LINES AND CROSS SLOPES AS SHOWN ON THE PLANS TO OBTAIN POSITIVE DRAINAGE WILL BE SUBJECT TO THE APPROVAL OF THE ENGINEER.

THE USGS 7.5 MINUTES QUADRANGLE SHEETS INDICATE THE "WATERS OF THE UNITED STATES" AND "WETLANDS" EXIST WITHIN THIS PROJECT AREA. THE ISSUE OF "WATERS OF THE UNITED STATES" AND "WETLANDS" FALLS UNDER THE CORP OF ENGINEERS (COE) TULSA DISTRICT REGULATORY DIVISION, BUT THE CITY IS OBLIGATED TO INSURE THAT ALL NECESSARY STATE AND FEDERAL PERMITS HAVE BEEN OBTAINED, PURSUIT TO 44 CFR 60.3. THEREFORE, THE APPLICANT IS REQUIRED TO SUBMIT DOCUMENTATION FROM THE COE SHOWING COE APPROVAL FOR THE PROPOSED WORK.

CONSTRUCTION ACTIVITIES THAT RESULT IN LAND DISTURBANCE OF EQUAL TO OR GREATER THAN ONE (1) ACRE, OR LESS THAN ONE (1) ACRE IF THEY ARE PART OF A LARGER COMMON PLAN OF DEVELOPMENT OR SALE THAT TOTALS AT LEAST ONE (1) ACRE MUST OBTAIN A PERMIT FROM ODEQ (FORM 605-002A) FOR STORM WATER DISCHARGES FROM CONSTRUCTION ACTIVITIES.

CONSTRUCTION NOTES (CONT.)

A COPY OF THE EROSION CONTROL SITE PLAN MUST BE ON SITE AT ALL TIMES AND MADE AVAILABLE TO THE INSPECTOR UPON REQUEST.

ANY AREA WITHIN THE PROJECT LIMITS DISTURBED BY THE CONTRACTORS CONSTRUCTION ACTIVITIES NOT SPECIFICALLY SHOWN ON THE PLANS i.e. (STAGING AREAS, STORAGE AREAS, HAUL ROADS, ETC.) SHALL BE RESTORED TO ORIGINAL CONDITION AS DIRECTED BY THE ENGINEER. ALL COST TO BE INCLUDED IN OTHER ITEMS.

3/11/2024 6:23:11 PM H:\PROJECTS\2789_Cr_osaRoads_Phase 4 \Roadway\Drawings\0903208-Phase 4-SUMMARY OF PAY QUANTITIES & NOTES (ROADWAY).dgn

UNLESS OTHERWISE NOTED ON THE PLANS, HORIZONTAL LOCATIONS OF EX. UTILITIES ARE APPROXIMATE & VERTICAL LOCATIONS OF EX. UTILITIES ARE UNKNOWN.

DESIGN	-	-	PHASE 4	OKLAHOMA COUNTY
DRAWN	-	-	SUMMARY OF PAY QUANTITIES & NOTES (ROADWAY)	STATE JOB NO. 090321081 SHEET NO. AR02
CHECKED	-	-		
APPROVED	-	-		
SQUAD	POE			

STATION LOCATION	REMOVAL OF CURB AND GUTTER (1)	REMOVAL OF CONCRETE PAVEMENT 619(B)	REMOVAL OF ASPHALT PAVEMENT 619(B)	REMOVAL OF CONCRETE SLOPEWALL (1)	REMOVAL OF CONCRETE MEDIAN BARRIER (1)	REMOVAL OF CONCRETE DIVIDING STRIP (1)	SAVING PAVEMENT (1)
	L.F.	S.Y.	S.Y.	L.F.	L.F.	L.F.	L.F.
CRL I-240							
397+00.00 TO 405+00.00	700.62		3,889.46				158.77
405+00.00 TO 420+00.00	1,041.02		15,960.03		1,500.55		199.13
420+00.00 TO 435+00.00	2,532.32	1,658.84	17,912.28	713.16	1,548.86		981.51
435+00.00 TO 450+00.00	619.22	5,401.24	3,239.97				
450+00.00 TO 452+00.00	200.14		1,401.11	424.03			
CL I-35							
85+00.00 TO 104+00.00	298.48	7,372.89	1,822.62		419.96	169.49	3,127.01
TOTALS	5,391.80	14,432.97	44,225.47	1,137.19	3,469.37	169.49	4,466.42

(1) QUANTITY SHOWN IS FOR INFORMATION PURPOSES ONLY. SEE GENERAL NOTE 3 THIS SHEET

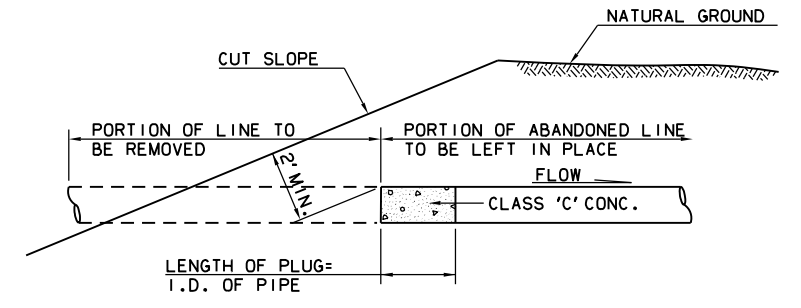

NOTE:
ALL PIPE LINES ABANDONED AND LEFT IN PLACE BY OTHERS AND STORM SEWERS, SANITARY SEWERS AND WATER LINES WHICH ARE ABANDONED UNDER THIS CONTRACT, SHALL BE REMOVED TO THE LIMITS OF CONSTRUCTION IN EXCAVATION SECTIONS AND PLUGGED AS SHOWN. IN EMBANKMENT SECTIONS "ABANDONED" SANITARY SEWER LINES (UNLESS OTHERWISE NOTED ON PLANS) AND WATER LINES "PLACED OUT OF SERVICE" SHALL BE PLUGGED AT BOTH ENDS. STORM SEWER, A PART OF WHICH WILL REMAIN IN SERVICE, SHALL BE PLUGGED AT THE R/W LINE. WHERE NOTED, THE EXISTING ABANDONED SANITARY SEWER LINES SHALL BE COMPLETELY FILLED WITH CLSM.

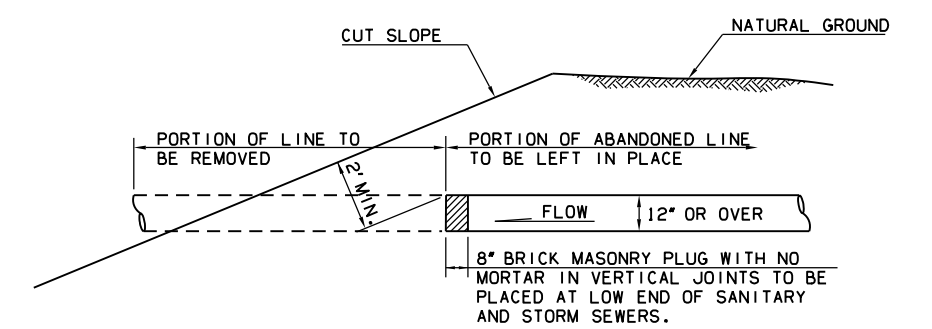

METHOD OF PLUGGING ABANDONED PIPE LINES
(COST OF PLUGGING SHALL BE INCLUDED IN THE UNIT PRICE BID ON OTHER ITEMS OF WORK.)

GENERAL NOTES

- ALL MATERIALS REMOVED SHALL BECOME THE PROPERTY OF THE CONTRACTOR, UNLESS SPECIFICALLY NOTED OTHERWISE.
- CLASS 'C' CONCRETE SHALL BE PLACED IN THE BOTTOM OF EACH MANHOLE AS SHOWN. MANHOLE THEN SHALL BE REMOVED TO DEPTH SPECIFIED AND BACK-FILLED IN ACCORDANCE WITH SEC. 619, OR FILLED WITH BRICK, BROKEN CONCRETE AND LOOSE SAND IN A MANNER TO ELIMINATE ALL VOIDS IN A MANNER APPROVED BY THE ENGINEER. COST TO BE INCLUDED IN PRICE BID FOR CLASS 'C' CONCRETE.
- PRICE BID SHALL INCLUDE, BUT IS NOT LIMITED TO, THE REMOVAL OF CURB, CURB & GUTTER, SIDEWALK, DRIVEWAYS, PAVEMENT SAWING, CONCRETE DITCH LINER, CONCRETE FLUMES, CONCRETE RUBBLE, CONCRETE DIVIDING STRIP, FOOTINGS, FOUNDATIONS, PITS, WING WALLS, STRUCTURES, STORM SEWERS, MANHOLES, PIPELINES, LIGHT POLES, FENCES, GUARDRAIL, POLES, SHEET METAL SIGNS, ETC., AND ANY OTHER NON-ORGANIC ITEM NOT SPECIFICALLY LISTED AS A REMOVAL PAY ITEM SHALL BE INCLUDED IN PRICE BID FOR REMOVAL OF STRUCTURES AND OBSTRUCTIONS.
- INTEGRAL CURB REMOVED W/CONCRETE PAVING SHALL BE INCLUDED IN THE PRICE BID FOR REMOVAL OF CONCRETE PAVING S.Y.
- ALL SALVAGE MATERIALS BELONGING TO THE CITY OF OKLAHOMA CITY SHALL BE DELIVERED TO THE OKC TRAFFIC OPERATIONS YARD, 1400 S. SHARTEL, OKLA. CITY, OK 405-297-2648
- CONCRETE RAIL REMOVED WITH EXISTING RETAINING WALL SHALL BE INCLUDED IN THE PRICE BID FOR REMOVAL OF RETAINING WALL L.F..

DESIGN	-	-	PHASE 4	OKLAHOMA COUNTY
DRAWN	-	-		
CHECKED	-	-		
APPROVED	-	-		
SQUAD	POE			

**SUMMARY SHEET
(SHEET 4 OF 10)**

STATE JOB NO. 09032108) SHEET NO. ARO6

CONST. PLUG (BRICK & MORTAR)
COST TO BE INCLUDED IN OTHER ITEMS OF WORK.

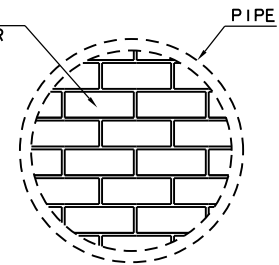

DETAIL OF TEMPORARY PIPE PLUG

9" H.E.S. CONCRETE PAV'T. (PATCHING)
(COST OF REMOVING EXIST. SURFACEING, BACKFILLING AND COMPACTING TO BE INCLUDED IN THE UNIT PRICE BID ON OTHER ITEMS OF WORK.)

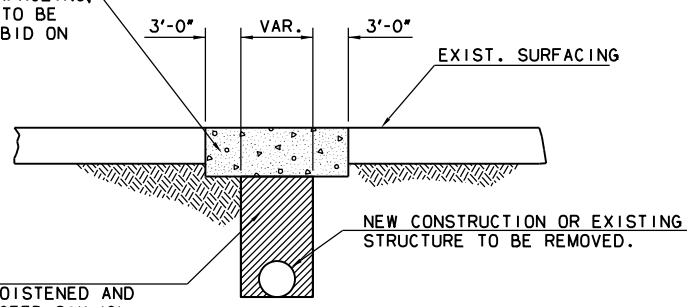

PATCHING DETAIL

(WHERE IT IS NECESSARY TO CUT EXISTING SURFACEING FOR REMOVAL OR CONSTRUCTION OF AN UNDERGROUND FACILITY)

BACKFILL AND COMPACT
BACKFILL MATERIAL SHALL BE MOISTENED AND COMPACTED IN LIFTS NOT TO EXCEED SIX (6) INCHES TO A DENSITY OF 95% STANDARD PROCTOR

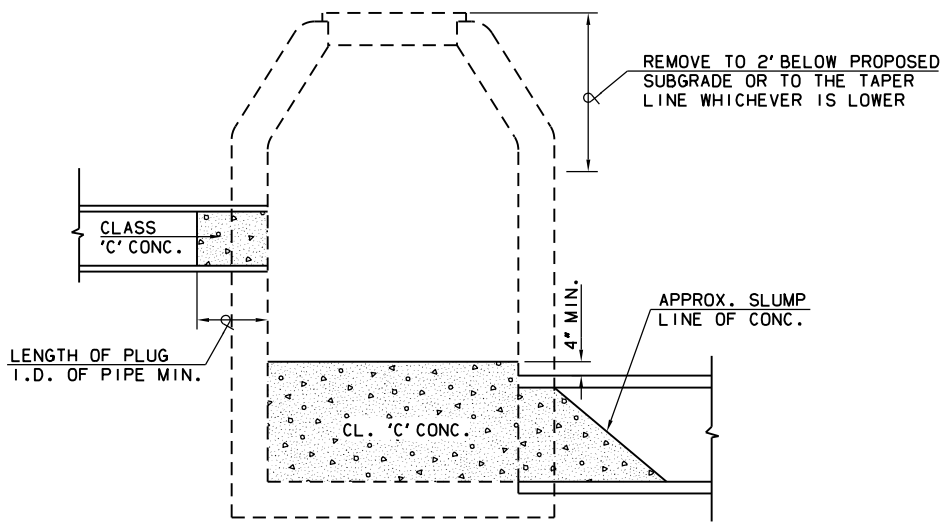

**DETAIL OF REMOVAL OF MANHOLES,
JUNCTION BOXES & INLETS**

**90% PLAN
SUBMITTAL**

3/11/2024

SUMMARY OF STORM SEWERS AND DRAINAGE STRUCTURES

STR NO.	STATION	OFFSET	DESCRIPTION	ROADWAY STANDARDS	UNCLASSIFIED EXCAVATION	STRUCTURAL EXCAVATION	CLASS AA CONCRETE	REINFORCING STEEL	MANHOLE		ADD'L. DEPTH MANHOLE		INLET SMD	ADD'L DEPTH INLET SMD	INLET LONG. BARRIER	ADD'L DEPTH INLET LONG. BARRIER	INLET CI DES.		ADD'L DEPTH IN INLET			INLET W/ LRG. JCT. BOX CI DES.	ADD'L DEPTH IN INLET W/ LRG. JCT. BOX CI DES.						
									611(A)		4'	5'					4'	5'	611(G)	611(G)				611(G)					
									EA	EA	EA	EA	EA	EA	EA	EA	EA	EA	EA	EA	EA	EA	EA	EA	EA	EA	EA	EA	EA
									VF	VF	VF	VF	VF	VF	VF	VF	VF	VF	VF	VF	VF	VF	VF	VF	VF	VF	VF	VF	VF
CD7	BL RAMP H STA. 430+68.89	CL	CONST. 8' X 4' X 74.38' LG. RCB W/ HEADWALL	RCB-C1-8(2-14), RCB-E1-H4-0-1, RCB-E1-H4-0-2, SBI-5	393.46	8.42	100.17	13726.92																					
CD8	BL RAMP C STA. 75+37.64	CL	CONST. 8' X 4' X 108.83' LG. RCB W/ HEADWALL	RCB-C1-8(2-14), RCB-E1-H4-0-1, RCB-E1-H4-0-2, SBI-5	679.49	12.32	132.21	17926.38																					
WB1	CL I-240 STA. 397+29.00	61.75' LT.	CONST. 4.0' DIA. MH ON EXIST. RCP	MJB-4, MFC-5					1		0																		
WB2	CL I-240 STA. 399+67.00	72.50' LT.	CONST. ILB TYPE 1 DES. 2 W/ 18" X 233.53' LG. RCP TO STR. WB1	CLB-2, SPI-5, PBB-1, FHTCP-4									1	3.69															
WB3	CL I-240 STA. 399+67.00	1.06' LT.	CONST. ILB TYPE 1 DES. 2 W/ 18" X 68.60' LG. RCP TO STR. WB2	CLB-2, SPI-5, PBB-1, FHTCP-4									1	2.66															
WB7	CL I-240 STA. 413+00.00	57.00' LT.	CONST. CI DES. 3(STD.) W/ LARGE JUNCT. BOX W/ 18" X 170.32' LG. RCP TO STR. WB9	CI-2, MJB-4, MFC-5, SPI-5, PBB-1, FHTCP-4																1	1.83								
WB9	CL I-240 STA. 414+75.00	63.00' LT.	CONST. 4.0' DIA. MH W/ 18" X 170.32' LG. RCP TO STR. WB11	MJB-4, MFC-5, SPI-5, PBB-1, FHTCP-4					1		1.53																		
WB11	CL I-240 STA. 416+50.00	57.00' LT.	CONST. CI DES. 3(STD.) W/ LARGE JUNCT. BOX W/ 24" X 220.38' LG. RCP TO STR. WB13	CI-2, MJB-4, MFC-5, SPI-5, PBB-1, FHTCP-4																1	5.5								
WB15	CL I-240 STA. 420+00.00	63.00' LT.	CONST. 4.0' DIA. MH W/ 18" X 121.63' LG. RCP TO STR. WB13	MJB-4, MFC-5, SPI-5, PBB-1, FHTCP-4					1		1.58																		
WB16	CL I-240 STA. 420+00.00	57.00' LT.	CONST. CI DES. 3(STD.) W/ 18" X 3.34' LG. RCP TO STR. WB15	CI-2, SPI-5, PBB-1, FHTCP-4														1		2.83									
WB20	CL I-240 STA. 423+00.00	63.00' LT.	CONST. 4.0' DIA. MH W/ 18" X 292.67' LG. RCP TO STR. WB15	MJB-4, MFC-5, SPI-5, PBB-1, FHTCP-4					1		1.37																		
WB21	CL I-240 STA. 423+00.00	57.00' LT.	CONST. CI DES. 3(STD.) W/ 18" X 3.34' LG. RCP TO STR. WB20	CI-2, SPI-5, PBB-1, FHTCP-4														1		2.83									

SHEET TOTAL:				1072.95	20.74	232.38	31653.3	4		4.48				2	6.35		2		5.66	2	7.33
										(1)	(1)		(1)		(1)		(1)	(1)		(1)	(1)

SUMMARY OF STORM SEWERS AND DRAINAGE STRUCTURES

STR NO.	INLET W/ SML. JCT. BOX CI DES.	ADD'L DEPTH IN INLET W/ SML. JCT. BOX CI	INLET FRAME & GRATE			CAST IRON HOODS		REINFORCED CONCRETE PIPE CLASS III		R.C. PIPE ARCH CLASS III	PREFAB. CULVERT END SEC., ROUND	PREFAB. CULVERT END SEC., ARCH	STANDARD BEDDING MATERIAL. B	STANDARD BEDDING MATERIAL. C	TRENCH EXCAVATION
			TYPE			4"	6"	613(A)		613(A)	613(L)	613(L)			
			2(STD.) EA	2(STD.) VF	A B C	MOUNT EA	BAR EA	18" LF	24" LF	28" X 18" LF	18" EA	28" X 18" EA			
CD7															
CD8															
WB1															
WB2								233.53				64.0		82.5	
WB3								68.6				36.2		18.8	
WB7			2	2	4			170.32				67.1		157.3	
WB9								170.32				67.1		142.0	
WB11			2	2	4			220.38				116.4		385.3	
WB15								121.63				47.9		130.6	
WB16			2	2	4			3.34				0.9		1.1	
WB20								292.67				115.3		282.1	
WB21			2	2	4			3.34				0.9		1.1	

		8	8	16		1063.75	220.38				515.8		1200.8
(1)	(1)	(1)	(1)	(1)	(1)					(1)	(1)	(1)	

3/11/2024 11:50:08 AM H:\PROJECTS\2789_02\Roadway\Drawings\0903208-Phase 4-SUMMARES (ROADWAY) STR.dgn

DESIGN	-	-	<p align="center">PHASE 4</p> <p align="center">SUMMARY SHEET (SHEET 5 OF 10)</p> <p>STATE JOB NO. <u>09032108</u> SHEET NO. <u>AR07</u></p>	OKLAHOMA COUNTY
DRAWN	-	-		
CHECKED	-	-		
APPROVED	-	-		
SQUAD		POE		

SUMMARY OF STORM SEWERS AND DRAINAGE STRUCTURES

STR NO.	STATION	OFFSET	DESCRIPTION	ROADWAY STANDARDS	UNCLASSIFIED EXCAVATION	STRUCTURAL EXCAVATION	CLASS AA CONCRETE	REINFORCING STEEL	MANHOLE		ADD'L. DEPTH MANHOLE		INLET SMD	ADD'L DEPTH INLET SMD	INLET LONG. BARRIER	ADD'L DEPTH INLET LONG. BARRIER	INLET CI DES.		ADD'L DEPTH IN INLET		INLET W/ LRG. JCT. BOX CI DES.	ADD'L DEPTH IN INLET W/ LRG. JCT. BOX CI DES.
									611(A)		TYPE 2	TYPE 2					611(G)		3(STD.)	3(STD.)		
									4'	5'							4'	5'				
WB23	CL I-240 STA. 426+00.00	63.00' LT.	CONST. 4.0' DIA. MH W/ 18" X 295.62' LG. RCP TO STR. WB20	MJB-4, MFC-5, SPI-5, PBB-1, FHTCP-4					1		1.35											
WB24	CL I-240 STA. 426+00.00	57.00' LT.	CONST. CI DES. 3(STD) W/ 18" X 3.34' LG. RCP TO STR. WB23	CI-2, SPI-5, PBB-1, FHTCP-4													1			2.83		
WB25	CL I-240 STA. 432+00.00	67.25' LT.	CONST. 4.0' DIA. MH W/ 18" X 105.90' LG. RCP W/ PCES TO OUTLET	MJB-4, MFC-5, PBB-1, PCES-4 FHTCP-4					1		6.14											
WB26	CL I-240 STA. 432+00.00	60.79' LT.	CONST. ILB TYPE 1 DES. 2 W/ 18" X 3.80' LG. RCP TO STR. WB25	CLB-2, SPI-5, PBB-1, FHTCP-4										1	8.51							
WB27	CL I-240 STA. 432+32.50	67.00' LT.	CONST. SMD TYPE 2 W/ 18" X 29.18' LG. RCP TO STR. WB25	SMD-4, SPI-5, PBB-1, FHTCP-4								1	0									
WB28	CL I-240 STA. 434+00.00	64.80' LT.	CONST. ILB TYPE 1 DES. 2 W/ 18" X 194.66' LG. RCP TO STR. WB26	CLB-2, SPI-5, PBB-1, FHTCP-4										1	4.02							
WB29	CL I-240 STA. 434+59.79	63.00' LT.	CONST. CI DES. 1(STD) W/ 18" X 55.70' LG. RCP TO STR. WB28	CI-2, SPI-5, PBB-1, FHTCP-4																		
WB30	CL I-240 STA. 437+16.00	58.79' LT.	CONST. CI DES. 3(STD) W/ 18" X 55.12' LG. RCP TO STR. EB6	CI-2, SPI-5, PBB-1, FHTCP-4													1			2.83		
WB31	CL I-240 STA. 443+74.00	68.19' LT.	CONST. CI DES. 3(STD) W/ 18" X 3.70' LG. RCP TO STR. H16	CI-2, SPI-5, PBB-1, FHTCP-4													1			2.95		
WB32	CL I-240 STA. 449+85.41	72.69' LT.	CONST. SMD TYPE 2 W/ 24" X 133.30' LG. RCP TO STR. WB33	SMD-4, SPI-5, PBB-1, FHTCP-4								1	4.8									
WB33	CL I-240 STA. 451+22.00	76.00' LT.	CONST. 4.0' DIA. MH W/ 24" X 70.75' LG. RCP TO STR. WB35	MJB-4, MFC-5, PBB-1, FHTCP-4					1		4.39											
WB34	CL I-240 STA. 451+22.00	70.05' LT.	CONST. ILB TYPE 1 DES. 2 W/ 18" X 3.29' LG. RCP TO STR. WB33	CLB-2, SPI-5, PBB-1, FHTCP-4										1	2.66							
SHEET TOTAL:									3		11.88	2	4.8	3	15.19		3		8.61			(1)
											(1)	(1)	(1)	(1)	(1)		(1)	(1)	(1)			(1)

SUMMARY OF STORM SEWERS AND DRAINAGE STRUCTURES

STR NO.	INLET W/ SML. JCT. BOX CI DES.		INLET FRAME & GRATE			CAST IRON HOODS		REINFORCED CONCRETE PIPE CLASS III		R.C. PIPE ARCH CLASS III	PREFAB. CULVERT END SEC., ROUND	PREFAB. CULVERT END SEC., ARCH	STANDARD BEDDING MATERIAL, B	STANDARD BEDDING MATERIAL, C	TRENCH EXCAVATION
	611(G)	ADD'L DEPTH IN INLET W/ SML. JCT. BOX CI	TYPE			4"	6"	613(A)		613(A)	613(L)	613(L)	CY	CY	CY
			2(STD.)	2(STD.)	A	B	C	MOUNT	BAR	18"	24"	28" X 18"			
WB23								295.62					116.5		303.6
WB24			2	2	4			3.34				0.9		1.1	
WB25								105.9		1		29		43.5	
WB26								3.8				1.5		3.7	
WB27								29.18				8		11.7	
WB28								194.66				53.3		85.7	
WB29			1		1			55.7				21.9		59.7	
WB30				2	2	4		55.12				15.1		22.8	
WB31				2	2	4		3.7				1.0		1.3	
WB32								133.3				70.4		226.6	
WB33								70.75				37.4		108.2	
WB34								3.29				1.3		3.5	
	(1)	(1)	1	6	6	13		954.36		1		247.2	109.1	871.4	
	(1)	(1)	(1)	(1)	(1)	(1)	(1)	(1)		(1)		(1)	(1)	(1)	

DESIGN	-	-	PHASE 4 OKLAHOMA COUNTY SUMMARY SHEET (SHEET 6 OF 10) STATE JOB NO. 09032108 SHEET NO. A008
DRAWN	-	-	
CHECKED	-	-	
APPROVED	-	-	
SQUAD	POE		

SUMMARY OF STORM SEWERS AND DRAINAGE STRUCTURES

STR NO.	STATION	OFFSET	DESCRIPTION	ROADWAY STANDARDS	UNCLASSIFIED EXCAVATION	STRUCTURAL EXCAVATION	CLASS AA CONCRETE	REINFORCING STEEL	MANHOLE		ADD'L. DEPTH MANHOLE		INLET SMD	ADD'L DEPTH INLET SMD	INLET LONG. BARRIER	ADD'L DEPTH INLET LONG. BARRIER	INLET CI DES.		ADD'L DEPTH IN INLET			INLET W/ LRG. JCT. BOX CI DES.	ADD'L DEPTH IN INLET W/ LRG. JCT. BOX CI DES.					
									611(A)		TYPE 2	TYPE 2					611(G)		2(STD.)	3(STD.)	2(STD.)			3(STD.)	611(G)			
									4'	5'							DES 2	DES 2								2(STD.)	3(STD.)	3(STD.)
									EA	EA							EA	VF										
C3	BL RAMP C STA. 82+95.10	11.50' LT.	EXTEND EXIST. 18" RCP 14.00' LG. TO STR C4	SPI-5, PBB-1, FHTCP-4																								
C4	BL RAMP C STA. 82+95.10	4.50' RT.	CONST. 4.0' DIA. MH W/ 18" X 53.26' LG. RCP TO OUTLET	MJB-4, MFC-5, SPI-5, PBB-1, FHTCP-4					1		0.87																	
C5	BL RAMP C STA. 85+00.00	10.00' RT.	CONST. CI DES. 3(STD) W/ LARGE JUNCT. BOX W/ 18" X 144.62' LG. RCP TO STR. C6	CI-2, MJB-4, MFC-5, SPI-5, PBB-1, FHTCP-4																	1		2.16					
C6	BL RAMP C STA. 86+50.00	10.00' RT.	CONST. CI DES. 3(STD) W/ LARGE JUNCT. BOX W/ 18" X 110.46' LG. RCP TO STR. C7	CI-2, MJB-4, MFC-5, SPI-5, PBB-1, FHTCP-4																	1		3.56					
C7	BL RAMP C STA. 87+65.00	20.00' RT.	CONST. 4.0' DIA. MH W/ 18" X 87.97' LG. RCP W/ PCES TO OUTLET	CI-2, MJB-4, MFC-5, SPI-5, PBB-1, FHTCP-4					1		2.91																	
H1	BL RAMP H STA. 414+55.00	8.00' LT.	CONST. CI DES. 2(STD) W/ 18" X 28.80' LG. RCP TO EXIST. MH	CI-2, SPI-5, PBB-1, FHTCP-4												1			3.55									
H2	BL RAMP H STA. 416+00.00	8.00' LT.	CONST. CI DES. 3(STD) W/ 18" X 137.04' LG. RCP TO STR. H1	CI-2, SPI-5, PBB-1, FHTCP-4													1			2.16								
H3	BL RAMP H STA. 420+88.00	8.00' LT.	CONST. CI DES. 3(STD) W/ LARGE JUNCT. BOX W/ 18" X 172.31' LG. RCP TO STR. H4	CI-2, MJB-4, MFC-5, SPI-5, PBB-1, FHTCP-4																	1		2.07					
H4	BL RAMP H STA. 422+65.00	9.00' LT.	CONST. 4.0' DIA. MH W/ 18" X 169.96' LG. RCP TO STR. H5	MJB-4, MFC-5, SPI-5, PBB-1, FHTCP-4					1		0																	
H5	BL RAMP H STA. 424+40.00	8.00' LT.	CONST. 4.0' DIA. MH W/ 18" X 104.22' LG. RCP TO STR. D1	MJB-4, MFC-5, SPI-5, PBB-1, FHTCP-4					1		0																	
H6	BL RAMP H STA. 426+20.00	8.00' LT.	CONST. CI DES. 3(STD) W/ LARGE JUNCT. BOX W/ 18" X 107.11' LG. RCP TO STR. H7	CI-2, MJB-4, MFC-5, SPI-5, PBB-1, FHTCP-4																	1		1.46					
H7	BL RAMP H STA. 427+34.00	8.00' LT.	CONST. CI DES. 3(STD) W/ LARGE JUNCT. BOX W/ 28" X 18" X 158.74' LG. RCP TO STR. H8	CI-2, MJB-4, MFC-5, SPI-5, PBB-1, FHTCP-4																	1		1.16					
SHEET TOTAL:									4		3.78			(1)	(1)		(1)	1	1	3.55	2.16	5	10.41					

SUMMARY OF STORM SEWERS AND DRAINAGE STRUCTURES

STR NO.	INLET W/ SML. JCT. BOX CI DES.	ADD'L DEPTH IN INLET W/ SML. JCT. BOX CI	INLET FRAME & GRATE			CAST IRON HOODS		REINFORCED CONCRETE PIPE CLASS III		R.C. PIPE ARCH CLASS III	PREFAB. CULVERT END SEC., ROUND	PREFAB. CULVERT END SEC., ARCH	STANDARD BEDDING MATERIAL. B	STANDARD BEDDING MATERIAL. C	TRENCH EXCAVATION		
			TYPE			4"	6"	613(A)		613(A)	613(L)	613(L)	CY	CY	CY		
			2(STD.)	2(STD.)	A	B	C	MOUNT	BAR	18"	24"	28" X 18"				18"	28" X 18"
					EA	VF	EA	EA	EA	EA	EA	EA				EA	EA
C3								14					3.8		4.8		
C4								53.26					14.6		21		
C5				2	2	4		144.62					57		137.6		
C6				2	2	4		110.5					43.5		105.1		
C7								88		1		24.1		34.7			
H1				2		2		28.8					11.3		32.3		
H2				2	2	4		137.04					37.5		57.8		
H3				2	2	4		172.31					46.5		51.4		
H4								169.96					46.6		55.7		
H5								104.22					28.6		34.1		
H6				2	2	4		107.11					29.3		53.6		
H7				2	2	4				158.74			78.9		171.4		
			14	12	26		1129.82		158.74	1		151.9	269.8	759.5			
			(1)	(1)	(1)	(1)	(1)				(1)	(1)	(1)				

3/11/2024 11:52:00 AM H:\PROJECTS\2789_CrossRoads_Phase 4\Roadway\Drawings\0903208-Phase 4-SUMMARIES (ROADWAY) STR.dgn

DESIGN	-	-	PHASE 4	OKLAHOMA COUNTY
DRAWN	-	-	SUMMARY SHEET (SHEET 8 OF 10) STATE JOB NO. 090321081 SHEET NO. AR10	
CHECKED	-	-		
APPROVED	-	-		
SQUAD	POE			

90% PLAN SUBMITTAL

3/11/2024

SUMMARY OF STORM SEWERS AND DRAINAGE STRUCTURES

Table with columns: STR NO., STATION, OFFSET, DESCRIPTION, ROADWAY STANDARDS, UNCLASSIFIED EXCAVATION, STRUCTURAL EXCAVATION, CLASS AA CONCRETE, REINFORCING STEEL, MANHOLE, ADD'L. DEPTH MANHOLE, INLET SMD, ADD'L DEPTH INLET SMD, INLET LONG. BARRIER, ADD'L DEPTH INLET LONG. BARRIER, INLET CI DES., ADD'L DEPTH IN INLET, INLET W/ LRG. JCT. BOX CI DES., ADD'L DEPTH IN INLET W/ LRG. JCT. BOX CI DES.

SHEET TOTAL: Summary row for the first table showing totals for excavation, manhole, barrier, and inlet depth.

SUMMARY OF STORM SEWERS AND DRAINAGE STRUCTURES

Detailed table for storm sewers and drainage structures with columns: STR NO., INLET W/ SML. JCT. BOX CI DES., ADD'L DEPTH IN INLET W/ SML. JCT. BOX CI, INLET FRAME & GRATE, CAST IRON HOODS, REINFORCED CONCRETE PIPE, R.C. PIPE ARCH, PREFAB. CULVERT END SEC., ROUND, PREFAB. CULVERT END SEC., ARCH, STANDARD BEDDING MATERIAL, B, STANDARD BEDDING MATERIAL, C, TRENCH EXCAVATION.

Summary row for the second table showing totals for various materials and trench excavation.

3/11/2024 11:52:25 AM H:\PROJECTS\2789_Cr-osaroads_Phase 4\Roadway\Drawings\0903208-Phase 4-SUMMARIES (ROADWAY) STR.dgn

Design and approval table with columns: DESIGN, DRAWN, CHECKED, APPROVED, SQUAD, POE, PHASE 4, OKLAHOMA COUNTY, SUMMARY SHEET (SHEET 9 OF 10), STATE JOB NO. 09032108, SHEET NO. AR11.

SUMMARY OF STORM SEWERS AND DRAINAGE STRUCTURES

STR NO.	STATION	OFFSET	DESCRIPTION	ROADWAY STANDARDS	UNCLASSIFIED EXCAVATION	STRUCTURAL EXCAVATION	CLASS AA CONCRETE	REINFORCING STEEL	MANHOLE		ADD'L. DEPTH MANHOLE	INLET SMD	ADD'L DEPTH INLET SMD	INLET LONG. BARRIER	ADD'L DEPTH INLET LONG. BARRIER	INLET CI DES.		ADD'L DEPTH IN INLET		INLET W/ LRG. JCT. BOX CI DES.	ADD'L DEPTH IN INLET W/ LRG. JCT. BOX CI DES.				
									611(A)							611(G)		611(G)							
									4'	5'						TYPE 2	TYPE 2	TYPE 1	TYPE 1			2(STD.)	3(STD.)	2(STD.)	3(STD.)
									EA	EA						VF	VF	EA	VF			EA	EA	VF	VF
H20	BL RAMP H STA. 447+62.00	8.00' LT.	CONST. CI DES. 3(STD.) W/ 18" X 3.74' LG. RCP TO STR. H19	CI-2, SPI-5, PBB-1, FHTCP-4														1	2.16						
H21	BL RAMP H STA. 449+23.00	15.50' LT.	CONST. 4.0' DIA. MH W/ 24" X 58.09' LG. RCP TO STR. WB32	MJB-4, MFC-5, SPI-5, PBB-1, FHTCP-4					1		2.09														
H22	BL RAMP H STA. 449+23.00	9.49' LT.	CONST. CI DES. 3(STD.) W/ 18" X 3.35' LG. RCP TO STR. H21	CI-2, SPI-5, PBB-1, FHTCP-4														1	2.83						
H23	BL RAMP H STA. 435+00.00	15.00' LT.	CONST. 4.0' DIA. MH W/ 18" X 6.99' LG. RCP TO STR. H24	MJB-4, MFC-5, SPI-5, PBB-1, FHTCP-4					1		0														
H24	BL RAMP H STA. 435+00.00	4.00' LT.	CONST. 4.0' DIA. MH W/ 18" X 95.54' LG. RCP TO STR. H11	MJB-4, MFC-5, SPI-5, PBB-1, FHTCP-4					1		0														
H25	BL RAMP H STA. 436+50.00	4.00' LT.	CONST. 4.0' DIA. MH W/ 18" X 145.22' LG. RCP TO STR. H11	MJB-3, MFC-4, SPI-4, SPB-1, FHTCP-3					1		0														
H26	BL RAMP H STA. 435+50.00	14.50' LT.	CONST. SMD TYPE 2 W/ 18" X 45.98' LG. RCP TO STR. H23	SMD-4, SPI-5, PBB-1, FHTCP-4								1	0												
H27	BL RAMP H STA. 439+40.00	25.77' LT.	CONST. SMD TYPE 2 W/ 18" X 32.63' LG. RCP TO STR. ENE29 (PHASE 1B)	SMD-4, SPI-5, PBB-1, FHTCP-4								1	0												
NNE4	CL NESR STA. 97+33.00	25.00' LT.	CONST. CI DES. 3(STD.) W/ 18" X 9.37' LG. RCP TO EXIST. STR.	CI-2, SPI-5, PBB-1, FHTCP-4														1	2.51						

SHEET TOTAL:						4		2.09		2	0					3		7.5			
GRAND TOTAL:	1072.95	20.74	232.38	31653.3	23	1	29.29	0.04	6	5.81	6	22.87	3	12	9.77	31.48	11	29.72			(1)
							(1)	(1)		(1)		(1)		(1)		(1)					(1)

SUMMARY OF STORM SEWERS AND DRAINAGE STRUCTURES

STR NO.	INLET W/ SML. JCT. BOX CI DES.	ADD'L DEPTH IN INLET W/ SML. JCT. BOX CI	INLET FRAME & GRATE			CAST IRON HOODS		REINFORCED CONCRETE PIPE CLASS III		R.C. PIPE ARCH CLASS III	PREFAB. CULVERT END SEC., ROUND	PREFAB. CULVERT END SEC., ARCH	STANDARD BEDDING MATERIAL, B	STANDARD BEDDING MATERIAL, C	TRENCH EXCAVATION					
			TYPE			4"	6"	613(A)								613(A)				
			2(STD.)	2(STD.)	A	B	C	MOUNT	BAR							18"	24"	28" X 18"	18"	28" X 18"
			EA	VF	EA	EA	EA	EA	EA							EA	EA	EA	EA	EA
H20				2	2		4							1	1.3					
H21															58.09					
H22				2	2		4								3.35					
H23															7.0					
H24															95.5					
H25															145.22					
H26															45.98					
H27															32.63					
NNE4				2	2		4								9.37					

			6	6	8	4	342.78	58.09				125	113	199
3	8.83	1	58	46	101	4	5393.61	1114.24	572.93	3	1	1100.3	1671.9	6071.7
	(1)	(1)	(1)	(1)	(1)	(1)						(1)	(1)	(1)

3/11/2024 11:52:29 AM H:\PROJECTS\2789_Cr-osaRoods_Phase 4\Roadway\Drawings\0903208-Phase 4-SUMMARIES (ROADWAY) STR.dgn

DESIGN	-	-	PHASE 4	OKLAHOMA COUNTY
DRAWN	-	-	SUMMARY SHEET (SHEET 10 OF 10)	STATE JOB NO. 090321081 SHEET NO. AR12
CHECKED	-	-		
APPROVED	-	-		
SQUAD	POE			

90% PLAN SUBMITTAL

2/27/2024

PAY QUANTITY NOTES

PAY ITEM NOTES (CONT.)

- (TC-1) THE CONTRACTOR SHALL FURNISH AND INSTALL SUCH LIGHTS, SIGNS, BARRICADES, AND PROVIDE FLAGGERS NECESSARY FOR THE CONTROL, SAFETY, AND MAINTENANCE OF TRAFFIC WHEN INSTALLING, RELOCATING OR DELIVERING PORTABLE LONGITUDINAL BARRIER.
- (TC-2) QUANTITY INCLUDES SUFFICIENT LENGTH OF PORTABLE LONGITUDINAL BARRIER TO PROVIDE FOR THE LONGEST SECTION SHOWN ON THE PLANS. THIS SAME BARRIER WILL BE USED ON OTHER DETOUR PHASES.
- (TC-15) PAY QUANTITY SHALL MEET THE REQUIREMENTS OF ODOT SPECIFICATION SECTION 711.10 TRAFFIC STRIPE PAINT ACRYLIC WATERBORNE WITH THE EXCEPTION OF THE ACRYLIC EMULSION POLYMER SHALL BE ROHM AND HASS HD-21A OR DOW CHEMICAL DT-400.
- (TC-16) PAINT SHALL CONFORM TO SECTION 711 "TRAFFIC STRIPE", OF THE O.D.O.T. STANDARD SPECIFICATIONS FOR HIGHWAY CONSTRUCTION (CURRENT EDITION).
IF CONSTRUCTION TRAFFIC STRIPE PAINT IS INSTALLED IN ACCORDANCE WITH THE MANUFACTURER'S SPECIFICATIONS AND FAILS DURING THE FIRST SIX MONTHS OF SERVICE, REPLACEMENT WILL BE MADE AT THE CONTRACTOR'S EXPENSE AND SHALL BE ACCOMPLISHED IN A TIMELY MANNER UPON NOTIFICATION BY THE ENGINEER OF SUCH FAILURE.
- (TC-17) INCLUDES AN ESTIMATED 14,487.00 L.F. (PAINT) (4" WIDE) WHITE 16,053.00 L.F. (PAINT) (4" WIDE) YELLOW STRIPE.
- (TC-20) ALL STRIPING TO BE PLACED ON TEMPORARY SURFACES OR ON SURFACES SCHEDULED TO BE REMOVED SHALL BE DONE WITH PAINT UNLESS OTHERWISE NOTED ON THE PLANS OR STANDARD DRAWINGS. TEMPORARY PAVEMENT MARKINGS PLACED ON FINISHED PAVEMENT OR EXISTING PAVEMENT TO REMAIN IN PLACE SHALL USE ONE REMOVABLE PAVEMENT MARKING TAPE CLASS A PAVEMENT MARKERS
- (TC-21) INCLUDED IN THE COST OF THIS ITEM SHALL BE INSTALLATION, MAINTENANCE, AND REMOVAL. THIS ITEM SHALL BE BID ACCORDINGLY.
- (TC-22) AMOUNT SHOWN IS AN APPROXIMATION AND THE ACTUAL AMOUNT OF REMOVAL, IF NECESSARY, SHALL BE DETERMINED BY THE ENGINEER. PRICE BID FOR PAVEMENT MARKING REMOVAL SHALL INCLUDE THE COST OF REMOVING STRIPE, ARROWS, WORDS, AND SYMBOLS, AS SHOWN IN THE PLANS, THESE ITEMS MAY CONSIST OF PLASTIC, PAINT OR NON-REMOVABLE MARKING TAPE.
- (TC-26) ALL CONSTRUCTION TRAFFIC CONTROL WILL BE IMPLEMENTED ACCORDING TO CONSTRUCTION PLANS, AND INSTALLED IN A MANNER APPROVED BY THE ENGINEER, IN ACCORDANCE WITH CHAPTER VI OF THE MANUAL ON UNIFORM TRAFFIC CONTROL DEVICES, (CURRENT EDITION), AND COMPLIANT WITH APPLICABLE O.D.O.T. STANDARD DRAWINGS. PRICE BID FOR THIS ITEM SHALL BE PAYMENT IN FULL FOR THE INSTALLATION, MAINTENANCE AND SUBSEQUENT REMOVAL OF ALL NECESSARY CONSTRUCTION TRAFFIC CONTROL DEVICES REQUIRED FOR COMPLETION OF THE PROJECT.
ALL SIGNS AND BARRICADES WHICH ARE SHOWN WITH TYPE 'A' LIGHTS IN THE STANDARD DRAWINGS SHALL HAVE THE CORRESPONDING LIGHT ATTACHED DURING NON-DAYLIGHT HOURS.
- (TC-33) ALL CONSTRUCTION WORK ZONE SIGNS SHALL HAVE FLUORESCENT SHEETING. THE FLOURESCENT SHEETING SHALL MEET THE REQUIREMENTS OF ASTM D4956 (LATEST REVISION)
THE MANUFACTURER SHALL FURNISH A TYPE 'D' CERTIFICATION IN ACCORDANCE WITH O.D.O.T. STANDARD SPECIFICATIONS (CURRENT EDITION) SUBSECTION 106.04. THE CERTIFICATION SHALL INCLUDE TEST RESULTS ON MATERIAL SUBMITTED FOR APPROVAL.
- (TC-61) ANY DAMAGE TO A FINISHED OR EXISTING SURFACE RESULTING FROM THE CONTRACTORS NEGLIGENCE IN THE REMOVAL OF CONSTRUCTION ZONE PAVEMENT MARKERS OR CHANNELIZING DEVICES AND THE BITUMINOUS ADHESIVE USED IN THEIR INSTALLATION, SHALL BE REPAIRED AT THE CONTRACTOR'S EXPENSE AND TO THE SATISFACTION OF THE ENGINEER.

- (TC-70) THIS ITEM IS AN ESTIMATED QUANTITY TO BE USED AS DEEMED NECESSARY BY THE ENGINEER.
- (TC-75) TEMPORARY PAVEMENT MARKINGS SHALL BE IN PLACE THE SAME DAY THAT EXISTING PAVEMENT MARKINGS ARE REMOVED FROM ANY ROADWAY OPEN TO TRAFFIC. ALSO, ALL TEMPORARY PAVEMENT MARKINGS SHALL BE REMOVED PRIOR TO THE INSTALLATION OF FINAL STRIPING.
- (TC-84) ~~600.00~~ CONSTRUCTION CALENDAR DAYS WERE USED TO COMPUTE THE SIGN DAY PAY ITEMS. THE AMOUNT OF CALENDAR DAYS USED TO COMPUTE THE SIGN DAY PAY ITEMS IS AN ESTIMATED QUANTITY ONLY, BASED ON THE CURRENT O.D.O.T. STANDARDS AND SUGGESTED CONSTRUCTION SEQUENCE FOR THIS PROJECT. THESE ESTIMATED SIGN DAY QUANTITIES MAY CHANGE AS THE PROJECT'S CONSTRUCTION TRAFFIC CONTROL IS MODIFIED DURING CONSTRUCTION.
- (TC-85) THESE SIGNS MUST BE ON THE OKLAHOMA DEPARTMENT OF TRANSPORTATION LIST OF APPROVED CHANGEABLE MESSAGE SIGNS. FOR A LIST OF THE APPROVED SIGNS GO TO THE OKLAHOMA DEPARTMENT OF TRANSPORTATION WEBSITE AT: <http://www.okladot.state.ok.us/traffic/qpl/index.php>

GENERAL CONSTRUCTION NOTES

- (C-1) ANY SIGNS AND/OR DELINEATORS WHICH ARE TO BE REMOVED DURING THIS PROJECT WILL BE STORED IN A PROTECTED AREA DESIGNATED BY THE RESIDENT ENGINEER, UNTIL SUCH A TIME THAT THEY ARE TO BE RESET BY THE CONTRACTOR. COST OF THIS WORK TO BE INCLUDED IN OTHER ITEMS OF WORK.
- (C-2) EXISTING ROADWAY SHALL REMAIN OPEN DURING CONSTRUCTION. THE CONTRACTOR SHALL BE RESPONSIBLE FOR PROPER BARRICADES, LIGHTS, AND SIGNING WITHIN THE LIMITS OF CONSTRUCTION. ALL CONSTRUCTION SIGNING WILL BE IMPLEMENTED ACCORDING TO CONSTRUCTION PLANS. CONSTRUCTION TRAFFIC CONTROL WILL BE INSTALLED IN A MANNER APPROVED BY THE ENGINEER, IN ACCORDANCE WITH CHAPTER VI OF THE MANUAL ON UNIFORM TRAFFIC CONTRAL DEVICES, (CURRENT EDITION), AND COMPLIANT WITH APPLICABLE O.D.O.T. STANDARD DRAWINGS.
- (C-3) THIS PROJECT SHALL BE CONSTRUCTED WITHOUT CLOSING TRAFFIC ON CROSS STREETS. A MINIMUM OF ONE LANE IN EACH DIRECTION SHALL BE MAINTAINED AT ALL TIMES.
- (C-6) THE STRUCTURAL DESIGN OF ALL POLES, MAST ARMS, HIGH-MAST POLES, AND OTHER SUPPORTS FOR SIGNS, LUMINAIRES, AND SIGNALS AS WELL AS THEIR CONNECTIONS SHALL BE IN ACCORDANCE WITH THE LATEST EDITION OF THE AASHTO STANDARD SPECIFICATIONS FOR STRUCTURAL SUPPORTS FOR HIGHWAY SIGNS, LUMINAIRES, AND TRAFFIC SIGNALS. THE MANUFACTURER SHALL ENSURE THE FOLLOWING ARE APPLIED TO THE DESIGN:
THE MINIMUM DESIGN WIND SPEED AND DESIGN LIFE AS REQUIRED IN THE AASHTO SPECIFICATIONS;
THE CALCULATED STRESSES AND FORCES FROM THE DESIGN LOADINGS DO NOT EXCEED THOSE REQUIRED IN THE AASHTO SPECIFICATIONS;
ALL MEMBERS ARE AT LEAST THE MINIMUM THICKNESS AS REQUIRED IN THE AASHTO SPECIFICATIONS;
THE ANCHOR BOLT DESIGN AND AMOUNT OF ANCHOR BOLTS TO BE USED SHALL BE AS REQUIRED IN THE AASHTO SPECIFICATIONS.
- (C-155) THE CONTRACTOR SHALL BE RESPONSIBLE FOR ANY DAMAGE HE MAY INFLECT TO THE EXISTING UNDERGROUND UTILITIES WITHIN THE PROJECT AREA AS A RESULT OF HIS DIGGING, TRENCHING, BORING, ETC... PRIOR TO DIGGING NEAR THE UTILITIES, THE CONTRACTOR SHALL CALL FOR A LIST OF ALL UNDERGROUND FACILITIES REGISTERED IN THE AREA OF CONSTRUCTION LISTED WITH THE FOLLOWING AGENCIES: THE "OKIE" NOTIFICATION CENTER 811 OR 1-800-522-6543 OR WWW.CALLOKIE.COM OR THE LOCAL COUNTY CLERK'S OFFICE.

PAY QUANTITES (TRAFFIC OPERATIONS)

0300 TRAFFIC			JP 09032(08)	
ITEM NO.		DESCRIPTION	UNIT	QUANTITY
857(A)	9205	CONSTRUCTION TRAFFIC STRIPE (PAINT)(6" WIDE)	(TC-15, TC-16, TC-17, TC-20, TC-75) LF	28,735.00
857(C)	9405	REMOVABLE PAVEMENT MARKING TAPE (6" WIDE)	(TC-70)(SP-1) LF	57,840.00
857(F)	9700	PAVEMENT MARKING REMOVAL (TRAFFIC STRIPE)	(TC-22, TC-70, TC-75) LF	57,840.00
858(A)	0220	PAVE.MARKERS CLASS A TYPE 2-B	(TC-26, TC-61, TC-70, TC-75)(SP-2) EA	4,400.00
858(A)	0232	PAVE.MARKERS CLASS A TYPE 2-E	(TC-26, TC-61, TC-70, TC-75)(SP-2) EA	2,200.00
877(B)	4300	DELIVER PORTABLE LONGITUDINAL BARRIER	(TC-1, TC-2) LF	12,168.00
877(C)	4400	RELOCATION OF PORTABLE LONGITUDINAL BARRIER	(TC-1) LF	7,776.00
880(B)	6300	CONSTRUCTION SIGNS 0 TO 6.25 SF	(TC-26, TC-33, TC-84)(SP-4) SD	6,300.00
880(B)	6310	CONSTRUCTION SIGNS 6.26 SF TO 15.99 SF	(TC-26, TC-33, TC-84)(SP-4) SD	350.00
880(B)	6320	CONSTRUCTION SIGNS 16.0 SF TO 32.99 SF	(TC-26, TC-33, TC-84)(SP-4) SD	7,350.00
880(C)	6410	CONSTRUCTION BARRICADES (TYPE III)	(TC-26, TC-70, TC-84)(SP-4) SD	350.00
880(E)	6607	WARNING LIGHTS (TYPE B)	(TC-26, TC-84)(SP-3, SP-4) SD	7,700.00
880(F)	6700	DRUMS	(TC-26, TC-84)(SP-4) SD	1,400.00
880(G)	6805	CHANNELIZER CONES	(TC-26, TC-70) EA	100.00
880(L)	7310	TRAFFIC SURVEILLANCE, OHP (NON BIDDABLE)	(TC-70) HR	4,500.00
882	8100	(SP) SMART WORK ZONE SYSTEM	(TC-84)(SP-4) SD	642.00
882	8105	(SP) SMART WORK ZONE SYS.-PORT.CHNG.MSG SN	(TC-84)(SP-4) SD	23,112.00
882	8110	(SP) SMART WORK ZONE SYS.-PORT.TRAF.SENSOR	(TC-84)(SP-4) SD	16,050.00
882	8115	(SP) SMART WORK ZONE SYS.-PAN-TILT-ZOOM CMRA	(TC-84)(SP-4) SD	1,284.00
882	8120	(SP) SMART WORK ZONE SYS-WEBSITE SYSTEM	(TC-84)(SP-4) SD	642.00
882	8125	(PL)SMART WORK ZONE SYSTEM SETUP	EA	1.00
882(A)	8210	PORT. CHANGEABLE MESSAGE SIGN	(TC-70, TC-84, TC-85)(SP-4) SD	1,400.00

PAY ITEM NOTES (TRAFFIC CONTROL)

- (SP-1) INCLUDES AN ESTIMATED 32330 L.F. (TAPE 6" WIDE) WHITE 25510 L.F. (TAPE 6" WIDE) YELLOW
- (SP-2) QUANTITY SHOWN INCLUDES 4400 EA. (WHITE) AND 2200 EA. (YELLOW) CONSTRUCTION ZONE PAVEMENT MARKERS (RAISED PAVEMENT MARKERS). THESE CONSTRUCTION ZONE PAVEMENT MARKERS SHALL BE EITHER "DAVIDSON PLASTICS: MODEL TOM", OR AN APPROVED EQUAL. PRICE BID FOR THIS ITEM SHALL INCLUDE THE INITIAL PLACEMENT, SUBSEQUENT REPLACEMENT, AND REMOVAL. THE CONSTRUCTION ZONE PAVEMENT MARKERS (FLEX TABS) SHALL BE INSTALLED IN ACCORDANCE WITH THE MANUFACTURER'S RECOMMENDATIONS AND AS SHOWN ON STANDARD DRAWING TCS21-1-(LATEST REVISION).
- (SP-3) QUANTITY INCLUDES 4 WARNING LIGHTS TO BE USED ON TYPE III BARRICADE AS DIRECTED BY THE ENGINEER
- (SP-4) 210 TOTAL CONSTRUCTION CALENDAR DAYS WERE USED TO COMPUTE THE SIGN DAYS ITEMS. THE TOTAL CLAENDAR DAYS ARE BROKEN DOWN BY PHASE TO CALCULATE THE SIGN DAYS PAY ITEMS PER PHASE. THE AMOUNT OF CALENDAR DAYS USED TO COMPUTE THE SIGN DAY PAY ITEMS IS AN ESTIMATED QUANTITY ONLY. BASED ON THE CURRENT O.D.O.T. STANDARDS AND SUGGESTED CONSTRUCTION SEQUENCE FOR THIS PROJECT. THESE ESTIMATED SIGN DAY QUANTITIES MAY CHANGE AS THE PROJECTS CONSTRUCTION TRAFFIC CONTROL IS MODIFIED DURING CONSTRUCTION THE CALENDAR DAYS PER PHASE ON THIS PROJECT. THE CALENDAR DAYS PER PHASE ON THIS PROJECT ARE AS FOLLOWS:
PHASE 1: 250 DAYS
PHASE 2: 350 DAYS
TOTAL: 600 DAYS

DESIGN	-	-
DRAWN	-	-
CHECKED	-	-
APPROVED	-	-
SQUAD		POE

SUMMARY OF PAY QUANTITIES (TRAFFIC OPERATIONS)

STATE JOB NO. 09032(08) SHEET NO. ATO1

REVISIONS		
NO.	DESCRIPTION	DATE

GENERAL CONSTRUCTION NOTES

THE CONTRACTOR SHALL BE RESPONSIBLE FOR ANY DAMAGE HE MAY INFLICT TO THE EXISTING UNDERGROUND UTILITIES WITHIN THE PROJECT AREA AS A RESULT OF HIS DIGGING, TRENCHING, BORING, ETC.... PRIOR TO DIGGING NEAR THE UTILITIES, THE CONTRACTOR SHALL CALL FOR A LIST OF ALL UNDERGROUND FACILITIES REGISTERED IN THE AREA OF CONSTRUCTION LISTED WITH THE FOLLOWING AGENCIES:
THE "OKIE" NOTIFICATION CENTER 811 OR (405) 522-6543 OR WWW.CALLOKIE.COM OR THE LOCAL COUNTY CLERK'S OFFICE.

ANY SIGNS AND/OR DELINEATORS WHICH ARE TO BE REMOVED DURING THIS PROJECT WILL BE STORED IN A PROTECTED AREA DESIGNATED BY THE RESIDENT ENGINEER UNTIL SUCH TIME THAT THEY ARE TO BE RESET BY THE CONTRACTOR. COST OF THIS WORK TO BE INCLUDED IN OTHER ITEMS OF WORK.

ALL BROKEN CONCRETE, WASTE MATERIAL, AND DEBRIS SHALL BECOME THE PROPERTY OF THE CONTRACTOR, AND SHALL BE REMOVED FROM THE LIMITS OF THE PROJECT AND DISPOSED OF IN AN AREA APPROVED BY THE ENGINEER. NO PAYMENT WILL BE MADE FOR THE DISPOSAL OF THIS MATERIAL.

ANY DAMAGE CAUSED BY THE CONTRACTOR TO ANY STRUCTURES, ROADWAY SURFACES, STRIPING, RAISED PAVEMENT MARKERS, GUARDRAIL, SLOPES, AND SIGNS SHALL BE REPAIRED AT CONTRACTORS EXPENSE TO THE SATISFACTION OF THE ENGINEER.

THIS PROJECT SHALL BE CONSTRUCTED WITHOUT CLOSING TRAFFIC ON CROSS STREETS. A MINIMUM OF ONE LANE IN EACH DIRECTION SHALL BE MAINTAINED AT ALL TIMES. SEE O.D.O.T. STANDARDS AND DETAIL DRAWINGS FOR MAINTENANCE OF LOCAL AND THROUGH TRAFFIC.

ALL REMOVED SIGNS, SIGN POSTS, BOLTS, MISCELLANEOUS HARDWARE, AND DELINEATORS SHALL BECOME THE PROPERTY OF THE CONTRACTOR AND SHALL BE REMOVED FROM THE LIMITS OF THE PROJECT AS APPROVED BY THE ENGINEER.

AFTER REMOVAL OF ANY SIGN FOOTINGS, THE HOLES SHALL BE FILLED WITH SOIL, TAMPED, AND SHAPED IN A MANNER APPROVED BY THE ENGINEER.

PAY QUANTITY NOTES

- (1) ITEM SHALL CONSIST OF CLASS A RAISED PAVEMENT MARKER WITH CRYSTAL (WHITE) REFLECTOR ON ONE SIDE AND RED REFLECTOR ON OPPOSITE SIDE.
- (2) ITEM SHALL CONSIST OF CLASS A RAISED PAVEMENT MARKER WITH WHITE REFLECTOR ON ONE SIDE AND RED REFLECTOR ON OPPOSITE SIDE.
- (3) PAY ITEM IS FOR THE COMPLETE INSTALLATION OF 14 IMPACT ATTENUATOR INSTALLATIONS FOR 70 MPH DESIGN VELOCITY IN ACCORDANCE WITH ODOT STANDARD DRAWING IA1-1-00. THE QUANTITIES PER INSTALLATION ARE 6.83 CY OF CLASS "C" CONCRETE, 281 LBS. OF REINFORCING STEEL AND 19 SAND FILLED IMPACT ATTENUATOR MODULES.
- (4) ALL PAVEMENT MARKERS ON THIS PROJECT SHALL BE INSTALLED BETWEEN THE END OF MARCH AND THE END OF SEPTEMBER.
- (TP-1) PAYMENT FOR THIS ITEM WILL BE BASED ON PLAN QUANTITY. SEE THE 2019 SPECIFICATIONS FOR HIGHWAY CONSTRUCTION.
- (TS-25) QUANTITY SHOWN INCLUDES 29,771 L.F. TRAFFIC STRIPE (MULTI-POLYMER) (WHITE), 18,930 L.F. TRAFFIC STRIPE (MULTI-POLYMER) (YELLOW) AND 2,100 L.F. TRAFFIC STRIPE (MULTI-POLYMER) (BLACK) AND WILL BE MEASURED BY THE LINEAR FOOT OF SIX INCH (6") WIDE TRAFFIC STRIPE.
- (TS-27) QUANTITY SHOWN INCLUDES 14,900 L.F. TRAFFIC STRIPE (MULTI-POLYMER) (WHITE) AND 0 L.F. TRAFFIC STRIPE (MULTI-POLYMER) (YELLOW) AND WILL BE MEASURED BY THE LINEAR FOOT OF TWELVE INCH (12") WIDE TRAFFIC STRIPE.
- (TS-28) QUANTITY SHOWN INCLUDES 500 L.F. TRAFFIC STRIPE (MULTI-POLYMER) (WHITE) AND WILL BE MEASURED BY THE LINEAR FOOT OF TWENTY-FOUR INCH (24") WIDE TRAFFIC STRIPE.
- (TS-32) THE AMOUNT SHOWN IS AN APPROXIMATION AND THE ACTUAL AMOUNT OF REMOVAL, IF NECESSARY, SHALL BE DETERMINED BY THE ENGINEER. PRICE BID FOR PAVEMENT MARKING REMOVAL (TRAFFIC STRIPE) SHALL INCLUDE COST OF REMOVAL OF ARROWS, WORDS, AND SYMBOLS. THE PAVEMENT MARKING TO BE REMOVED SHALL BE CONSIDERED THERMOPLASTIC AND BID ACCORDINGLY.

DURING REMOVAL OF EXISTING STRIPING AND REPLACEMENT WITH NEW STRIPING, PERMANENT STRIPING SHALL BE REPLACED WITHIN 48 HOURS AFTER OLD STRIPING IS REMOVED.
- (TS-33) INCLUDED IN THIS PAY ITEM IS ALL HARDWARE ASSOCIATED WITH PROPERLY ANCHORING AND MOUNTING THE HIGHWAY SIGN IN ACCORDANCE WITH O.D.O.T. PLANS AND STANDARD DRAWINGS SSA1-1 AND SSP1-1- (LATEST REVISION).
- (TS-36) PRICE BID FOR SAND FILLED IMPACT ATTENUATOR(S) SHALL INCLUDE THE COST FOR OM1-1 OR OM1-3 SIGN(S) WITH TYPE VIII SHEETING, AND THE REMOVAL OF ANY OM-3 OR OM-3E SIGN(S), POST(S) AND FOOTING(S), IF PRESENT, AND ALL OTHER INCIDENTALS NECESSARY TO COMPLETE THE INSTALLATION ACCORDING TO PERTINENT O.D.O.T. STANDARD DRAWINGS.

PAY QUANTITIES			
JP 09032(08)			
0301 TRAFFIC SIGNING & STRIPING			
ITEM	DESCRIPTION	UNIT	TOTAL
509(D) 0500	CLASS C CONCRETE	(3) CY	95.62
511(A) 2200	REINFORCING STEEL	(3) LB	3934.00
516(A) 8240	DRILLED SHAFT 60" DIAMETER	(TP-1) LF	595.00
804(A) 2200	STRUCTURAL CONCRETE	(TP-1) CY	15.38
804(B) 2300	REINFORCING STEEL	(TP-1) LB	3404.00
850(A) 1200	SHEET ALUMINUM SIGNS	SF	265.50
850(B) 1310	EXTRUDED ALUMINUM PANEL SIGNS	SF	1027.03
850(B) 1320	EXTR. ALUM. PAN. SGN. (OVRHD SIGNS)	SF	5880.75
851(A) 2200	4"@13 GALV. STEEL WD. FLANGE BM. POST	LF	89.00
851(A) 2210	6"@20 GALV. STEEL WD. FLANGE BM. POST	LF	230.70
851(A) 2220	8"@31 GALV. STEEL WD. FLANGE BM. POST	LF	174.30
851(B) 2305	2"@3.65 GALV. STL. PIPE POST	(TS-33) LF	24.00
851(B) 2310	2 1/2"@5.79 GALV. STL. PIPE POST	(TS-33) LF	109.00
851(C) 2415	2" SQUARE TUBE POST	(TS-33) LF	290.00
852(D) 3504	OVHD. SN. STR., MONOTUBE TYPE B 55'	EA	4.00
852(D) 3506	OVHD. SN. STR., MONOTUBE TYPE B 60'	EA	2.00
852(D) 3516	OVHD. SN. STR., MONOTUBE TYPE B 75'	EA	2.00
852(E) 3600	OVHD. SN. STR., MONOTUBE TYPE C	EA	1.00
856(A) 8204	TRAFFIC STRIPE (MULTI-POLY.) (6" WIDE)	(TS-25) LF	50801.00
856(A) 8212	TRAFFIC STRIPE (MULTI-POLY.) (12" WIDE)	(TS-27) LF	14900.00
856(A) 8216	TRAFFIC STRIPE (MULTI-POLY.) (24" WIDE)	(TS-28) LF	500.00
856(B) 8304	TRAFFIC STRIPE (MULTI-POLY.) (ARROWS)	EA	2.00
857(F) 9700	PAVEMENT MRKNG. REMOVAL (TRAF. STRP)	(TS-32) LF	25000.00
858(A) 0224	PAVE. MARKERS CLASS A TYPE 2-C	(1,2,4) EA	433.00
870(A) 1100	SAND FILLED IMPACT ATTEN. MODULE	(TS-36)(3) EA	266.00

G:\0\Projects\1-2457E Design\1-240-1-35 Phase IV - OKLA CAD\A102-0903208-SUMMARY OF PAY QUANTITIES & NOTES_SIGNING & STRIPING.dgn 03-12-24

Design	MSH	03-12-24
Drawn	SB	03-12-24
		

SUMMARY OF PAY QUANTITIES & NOTES (SIGNING & STRIPING)

State Job No. 09032(08) Sheet No. AT02

REVISIONS		
NO.	DESCRIPTION	DATE

GENERAL CONSTRUCTION NOTES

SYMBOLS AND LEGENDS ARE DIAGRAMMATIC ONLY AND LOCATIONS SHALL BE ADJUSTED FOR EXISTING FIELD CONDITIONS, BUT NO MAJOR ALTERATIONS OR RELOCATIONS WILL BE MADE WITHOUT FIRST CONSULTING WITH THE TRAFFIC ENGINEERING DIVISION AT (405)521-2861.

ALL BROKEN CONCRETE, WASTE MATERIAL, AND DEBRIS SHALL BECOME THE PROPERTY OF THE CONTRACTOR, AND SHALL BE REMOVED FROM THE LIMITS OF THE PROJECT AND DISPOSED OF IN AN AREA APPROVED BY THE ENGINEER. NO PAYMENT WILL BE MADE FOR THE DISPOSAL OF THIS MATERIAL.

THE CONTRACTOR SHALL BE RESPONSIBLE FOR ANY DAMAGE HE MAY INFLICT TO THE EXISTING UNDERGROUND UTILITIES WITHIN THE PROJECT AREA AS A RESULT OF HIS DIGGING, TRENCHING, BORING, ETC.... PRIOR TO DIGGING NEAR THE UTILITIES, THE CONTRACTOR SHALL CALL FOR A LIST OF ALL UNDERGROUND FACILITIES REGISTERED IN THE AREA OF CONSTRUCTION LISTED WITH THE FOLLOWING AGENCIES:

THE "OKIE" NOTIFICATION CENTER 811 OR (405)522-6543 OR WWW.CALLOKIE.COM OR THE LOCAL COUNTY CLERK'S OFFICE.

(TL-35) SEE SERVICE POLE SCHEDULE; FOR ADDITIONAL INFORMATION CONCERNING THE SERVICE POLE, CONTACT THE FOLLOWING PRIOR TO INSTALLATION:

PERSON'S NAME.....KOLTON HOWRY
WITH THE COMPANY/CITY OF.....OEC

(TP-1) PAYMENT FOR THIS ITEM WILL BE BASED ON PLAN QUANTITY. SEE THE 2019 SPECIFICATIONS FOR HIGHWAY CONSTRUCTION.

(1) THESE PULL BOXES ARE TO BE USED IN THE PORTABLE CONCRETE THAT WILL HAVE LIGHT POLES INSTALLED IN THEM ON I-240 AS SHOWN IN THE PLANS.

(2) REMOVED LIGHT POLES SHALL BECOME THE PROPERTY OF ODOT AND SHALL BE DELIVERED TO A LOCATION DESIGNATED BY THE ENGINEER.

(3) THIS WIRE SHALL BE ALUMINUM WIRE ONLY. ALL ASSOCIATED HARDWARE (CONNECTORS, SPLICES, BREAKERS, ETC.) NECESSARY TO ASSURE PROPER INSTALLATION AND PERFORMANCE OF THIS ALUMINUM WIRE IN ACCORDANCE WITH CURRENT SPECIFICATIONS, STANDARDS AND PRACTICE SHALL BE INCLUDED IN THE PRICE BID FOR THIS ITEM.

(4) THE UNDERPASS LIGHT FIXTURES TO BE USED ON THIS PROJECT SHALL BE HOLOPHANE W4GLD FIXTURES OR AN APPROVED EQUAL.

(5) THE ROADWAY LIGHT FIXTURES TO BE USED ON THIS PROJECT SHALL BE HOLOPHANE MGLEDM-P3-30K-480V-MR FIXTURES OR AN APPROVED EQUAL.

(7) PAY ITEM IS FOR THE INSTALLATION OF THREE (3) 45' MTG & 10' HMLA (G.STL.) POLES AS SHOWN IN THE LIGHT POLE SCHEDULE.

(8) THE PRICE BID FOR THIS PAY ITEM SHALL INCLUDE THE COST OF INSTALLING THE 129 40' MOUNTING HEIGHT ROUND GALVANIZED STEEL POLES AND ALSO THE 3 45' MOUNTING HEIGHT ROUND GALVANIZED STEEL POLES AS SPECIFIED IN THE PLANS AND IN ACCORDANCE WITH ODOT STANDARDS AND SPECIFICATIONS.

LIGHTING PAY QUANTITIES

Phase 1 for I-240 & I-35 Interchange Project in Oklahoma City, OK

0301 TRAFFIC		DESCRIPTION	UNIT	TOTAL
509(B)	0320	CLASS A CONCRETE (TP-1)	CY	33.72
802(A)	0200	3/4" GALV. STEEL ELECTRICAL CONDUIT EXPOSED (TP-1)(1)	LF	190.00
802(A)	0220	1 1/4" GALV. STEEL ELECTRICAL CONDUIT EXPOSED (TP-1)	LF	80.00
802(B)	0320	2" PVC SCH. 40 PLASTIC CONDUIT BORED (TP-1)	LF	395.00
802(B)	0324	2" PVC SCH. 40 PLASTIC CONDUIT TRENCHED (TP-1)	LF	1055.00
802(C)	0430	2" HIGH DENSITY PE PIPE - TRENCHED (TP-1)	LF	2195.00
802(E)	0610	JUNCTION BOX (8" X 8" X 6")	EA	4.00
803(A)	1200	PULL BOX (2)	EA	13.00
803(A)	1210	PULL BOX (SIZE I) (2)	EA	8.00
804(A)	2200	STRUCTURAL CONCRETE (TP-1)	CY	480.00
804(B)	2300	REINFORCING STEEL (TP-1)	LB	5640.00
805(A)	3228	(PL) REMOVAL OF LIGHT POLE (6)	EA	32.00
806(D)	4608	36' MTG. HT. HL. PTP. (G.STL.)	EA	12.00
807	5120	BREAKAWAY BASE (DES. B)	EA	10.00
809(A)	7200	ROADWAY LUMINAIRE (5)	EA	35.00
809(B)	7300	UNDERPASS LUMINAIRE (4)	EA	6.00
810(A)	8200	SERVICE POLE (TL-35)	EA	1.00
811	9115	1/C NO. 4 ELECTRICAL CONDUCTOR (TP-1)(3)	LF	10100.00
811	9130	1/C NO. 10 ELECTRICAL CONDUCTOR (TP-1)(1)	LF	490.00
811	9135	1/C NO. 12 ELECTRICAL CONDUCTOR (TP-1)	LF	4625.00
812	0140	140' HIGH MAST POLE(G.ST.)	EA	16.00

G:\0\Projects\1-245\TE Design\I-240-I-35 Phase IV - OK\CAD\A103-0903208-SUMMARY OF PAY QUANTITIES & NOTES_LIGHTING.dgn

Design	MSH	03-12-24
Drawn	SB	03-12-24



**SUMMARY OF PAY QUANTITIES
& NOTES (LIGHTING)**

State Job No. 09032(08) Sheet No. AT03

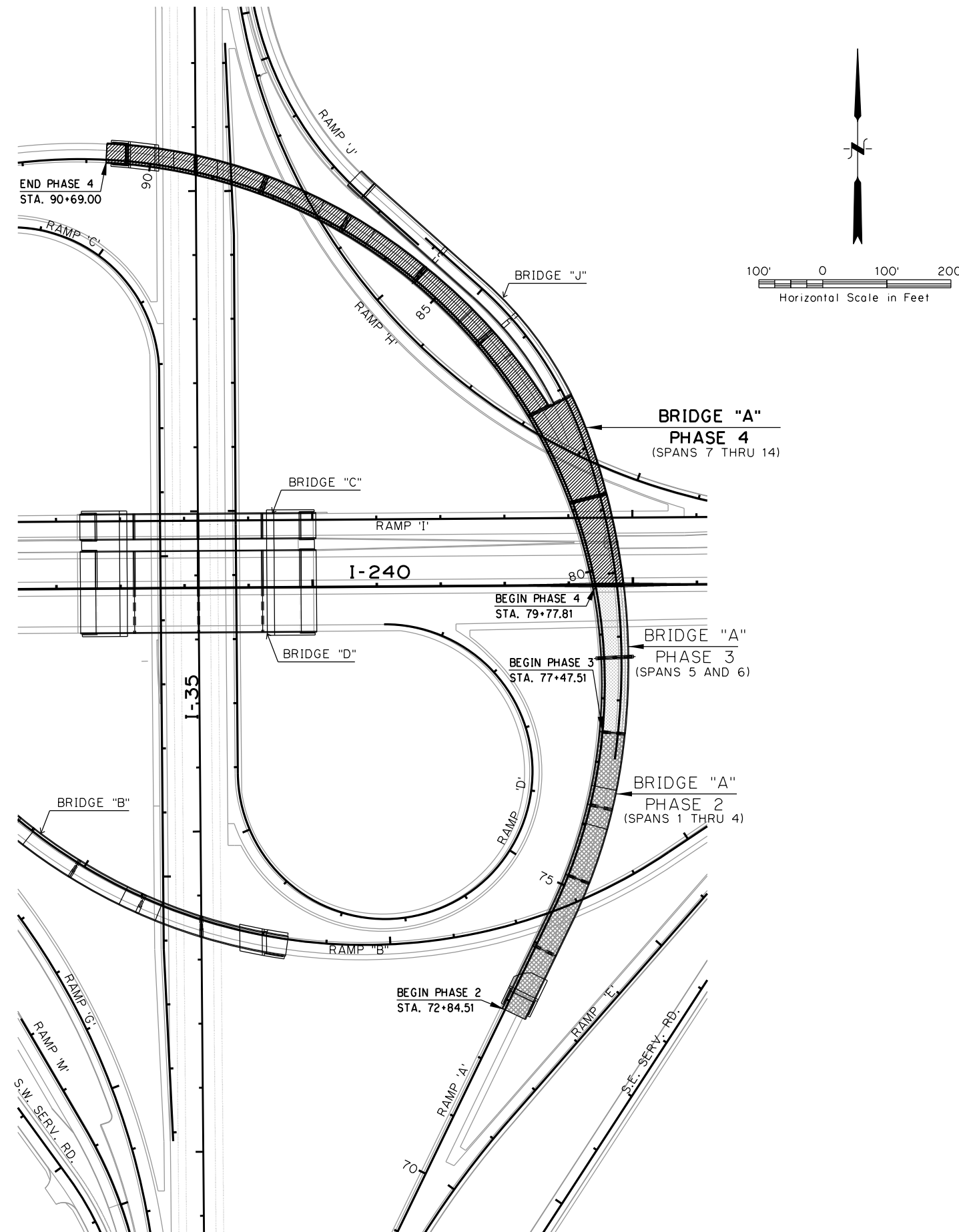

BRIDGE "A"
CONSTRUCTION PHASES

BRIDGE "A" PHASE 4 INDEX OF SHEETS

SHEET NO.	DESCRIPTION
AB01	SUMMARY OF PAY QUANTITIES (BRIDGE)
AB02	GENERAL NOTES (BRIDGE)
B001	BRIDGE "A" SEQUENCE MAP AND SHEET INDEX
B002-B004	GENERAL PLAN & ELEVATION
B005	DESIGN DATA AND SUMMARY OF QUANTITIES
B006-B009	FOUNDATION REPORT
B010-B011	SUBSTRUCTURE LAYOUT
B012	EXCAVATION DIAGRAMS AND UNDERDRAIN DETAILS
B013-B014	ABUTMENT DETAILS
B015-B029	PIER DETAILS
B030-B033	PIER PROTECTION AND BARRIER TRANSITION DETAILS
B034-B040	SUPERSTRUCTURE DETAILS
B041-B042	LONGITUDINAL SECTION AND SLAB POURING SEQUENCE
B043-B046	PARAPET LAYOUT
B047	END BARRIER LAYOUT
B048	GIRDER BRACING DETAILS
B049-B058	PLATE GIRDER DETAILS
B059-B061	FRAMING PLAN AND DIAPHRAGM DETAILS
B062	BEARING ASSEMBLY DETAILS
B063-B064	APPROACH SLAB DETAILS
B065-B066	SLOPE WALL DETAILS
B067	DRAIN AT END OF BRIDGE DETAILS
2009 BRIDGE STANDARDS	
STD.	EJ-DTL
STD.	EJ-SK
STD.	EJ-SQ
STD.	FSHP-42-2
STD.	HP1-2
2019 ROADWAY STANDARDS	
STD.	LECS-5
STD.	LTU-5
STD.	PUD-4
STD.	SPI-5

3/1/2024 3:19:30 PM H:\PROJECTS\2789_CrossRoads_Phase 4\Bridges\Drawings\Ph4 Bridges\Bridges\I-35 & I-240\PhaseMap_Bridge A.dgn

PHASE 4		OKLAHOMA COUNTY	
DESIGN		BRIDGE "A"	RAMP "A" AT I-35 & I-240 INTERCHANGE
DRAWN		<p align="center">BRIDGE "A" SEQUENCE MAP AND SHEET INDEX</p>	
CHECKED			
APPROVED			
SQUAD	POE	STATE JOB NO. 09032(08)	SHEET NO. B001

CURVE DATA RA-3, RJ-1, RJ-2
SEE ROADWAY SHEETS: "GEOMETRIC COORDINATE POINT TABLES" FOR CURVE DATA.

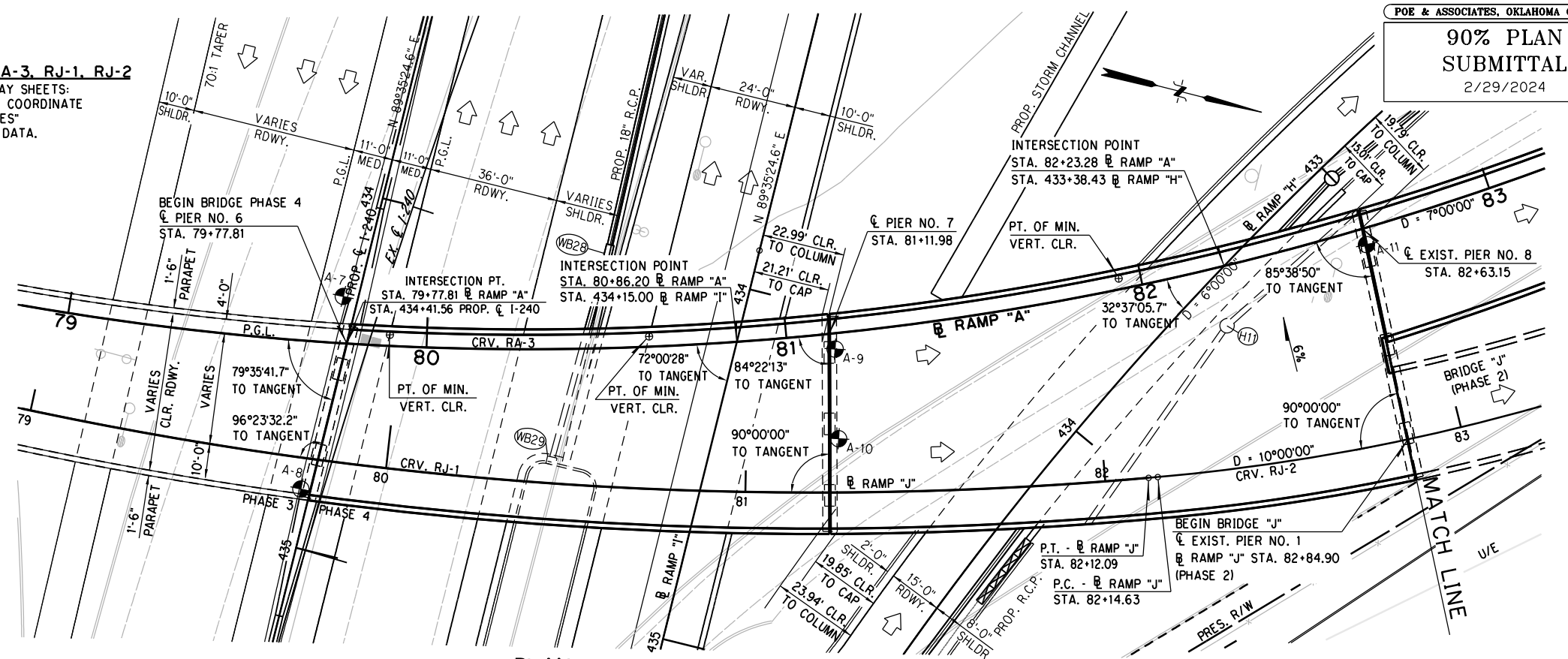
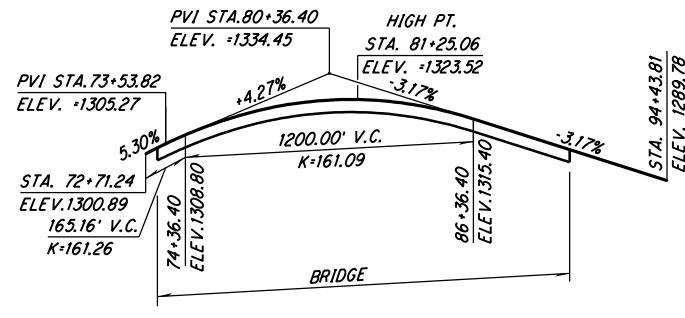
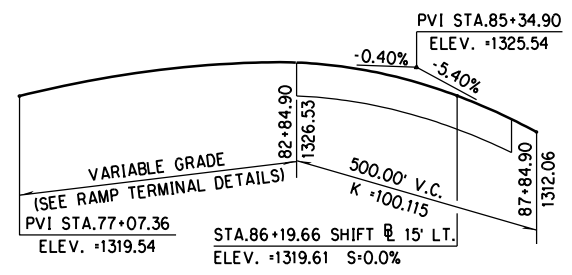

BM 36 ~ SQUARE ON SOUTH CURB RETURN AT SE 79TH, NW OF ICE RINK 234.04' RT. @ I-35 STA. 66+79.07 ELEV. +1290.63

BM 57 ~ SQUARE ON TOP OF HEADWALL 388.69' RT. @ I-35 STA. 84+07.6 ELEV. +1286.09

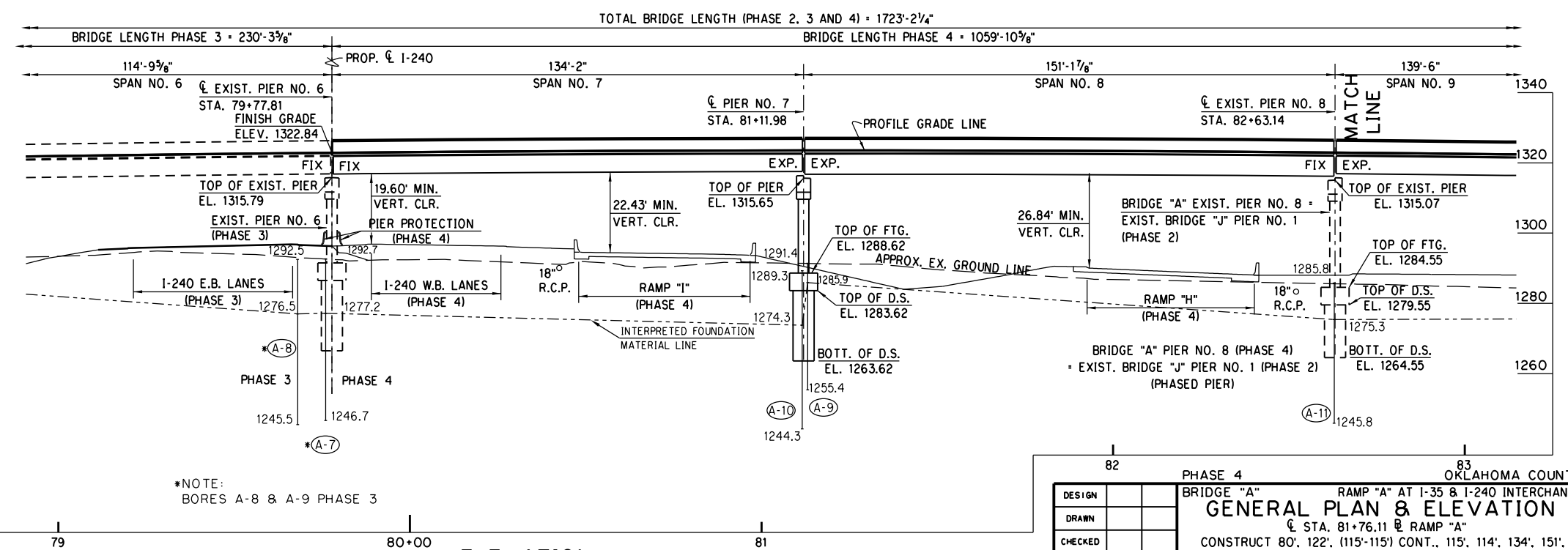
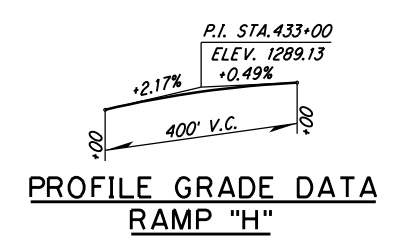
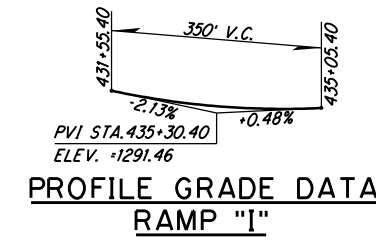
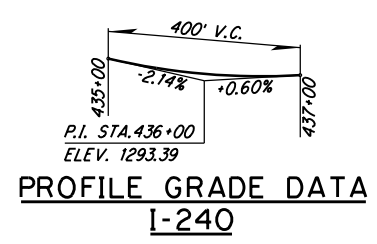

*NOTE: BORES A-8 & A-9 PHASE 3

DESIGN		PHASE 4	OKLAHOMA COUNTY
DRAWN		BRIDGE "A"	
CHECKED		GENERAL PLAN & ELEVATION	
APPROVED		RAMP "A" AT I-35 & I-240 INTERCHANGE	
SQUAD	POE	@ STA. 81+76.11 @ RAMP "A"	
		CONSTRUCT 80', 122', (115'-115') CONT., 115', 114', 134', 151', 2(139'-139'), (106'-110') CONT., PLATE GIRDER SPANS	
		VARIABLE CLEAR ROADWAY W/ 42" F-SHAPED PARAPET	
		STATE JOB NO. 09032(08) SHEET NO. 002	

3/1/2024 3:19:37 PM H:\PROJECTS\2789_CrossRoads_Phase 4\Bridges\Drawings\Phase 4\Bridges\Bridges\Phase 4 Bridge A GPE.dgn

BM 5 - X ON CURB AT CENTER OF INLET
258.21' LT.
@ I-35 STA. 85+81.41 ELEV. 1282.41

BM 6 - CHISELED SQUARE TOP OF EAST
SIDE OF DRAINAGE CANAL 406.13' LT.
@ I-240 STA. 418+82.24 ELEV. 1265.30

INTERSECTION POINT
STA. 87+26.09 @ RAMP "A"
STA. 428+37.77 @ RAMP "H"

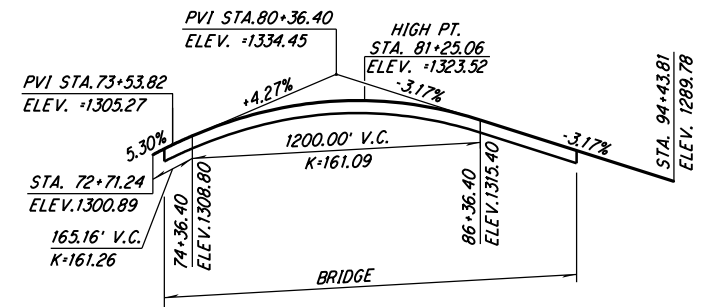
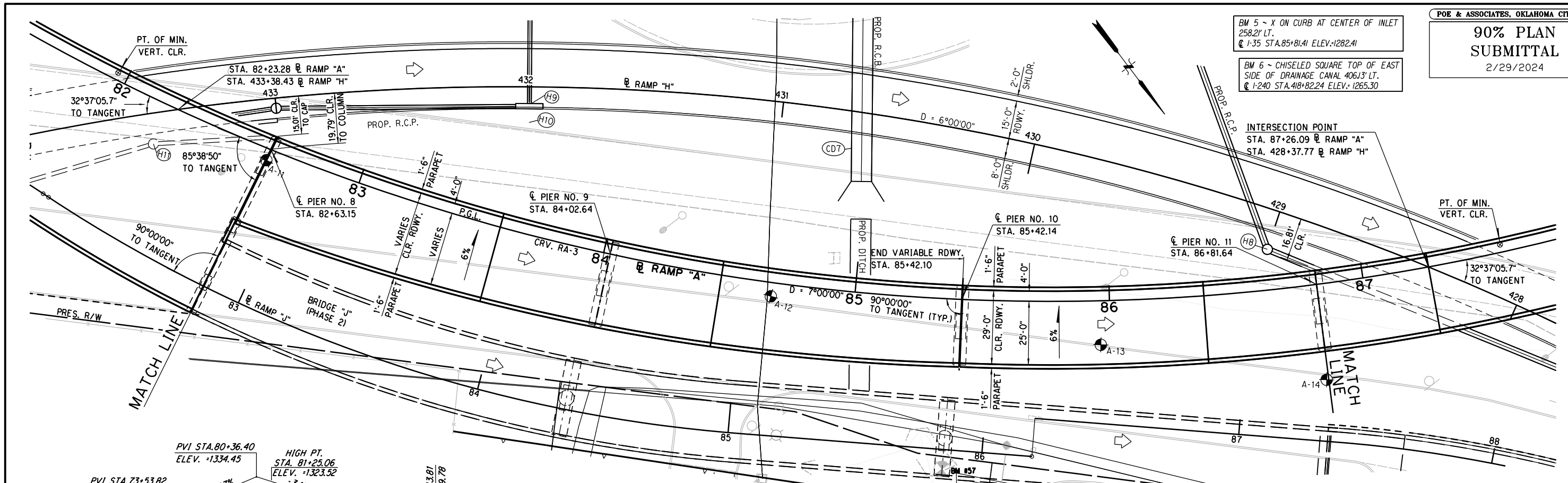

PROFILE GRADE DATA
RAMP "A"

CURVE DATA RA-3
SEE ROADWAY SHEETS:
"GEOMETRIC COORDINATE POINT
TABLES" FOR CURVE DATA.

PLAN
SCALE: 1" = 20'-0"

BM 57 - SQUARE ON TOP
OF HEADWALL 388.69' RT.
@ I-35 STA. 84+07.16 ELEV. 1286.09

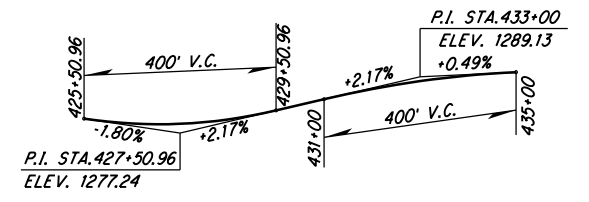

PROFILE GRADE DATA
RAMP "H"

TOTAL BRIDGE LENGTH (PHASE 2, 3 AND 4) = 1723'-2 1/4"

BRIDGE LENGTH PHASE 4 = 1059'-10 3/8"

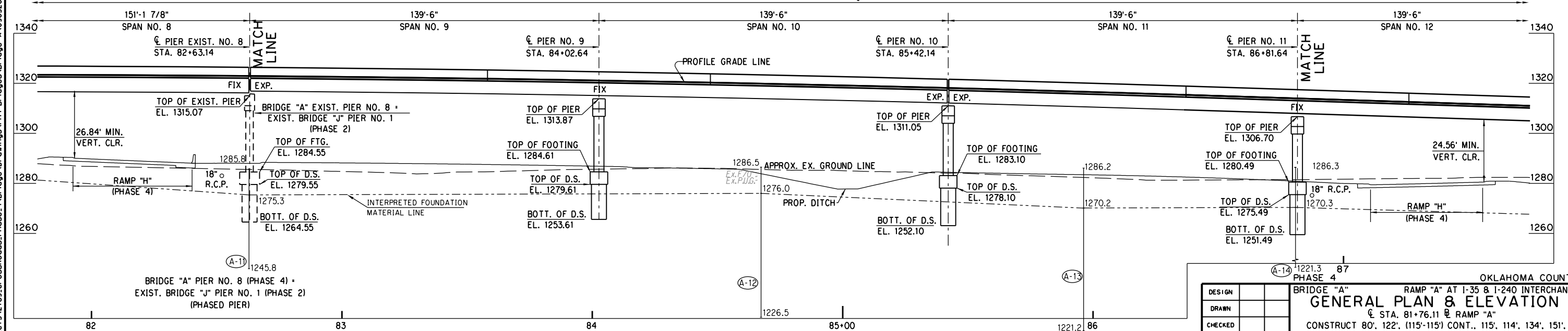

ELEVATION
SCALE: 1" = 20'-0"

DESIGN	
DRAWN	
CHECKED	
APPROVED	
SQUAD	POE

OKLAHOMA COUNTY
BRIDGE "A" RAMP "A" AT I-35 & I-240 INTERCHANGE
GENERAL PLAN & ELEVATION
@ STA. 81+76.11 @ RAMP "A"
CONSTRUCT 80', 122', (115'-115') CONT., 115', 114', 134', 151',
2(139'-139'), (106'-110') CONT., PLATE GIRDER SPANS
VARIABLE CLEAR ROADWAY W/ 42" F-SHAPED PARAPET
STATE JOB NO. 09032(08) SHEET NO. 003

3/1/2024 3:19:40 PM H:\PROJECTS\2789_CrossRoads\Phase 4\Bridges\Drawings\Ph4 Bridges\Bridges\A\0903208 P4 Bridge A GPE.dgn

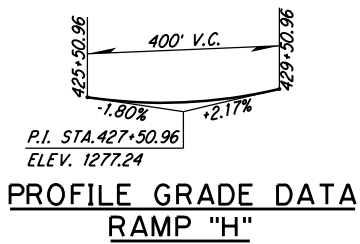
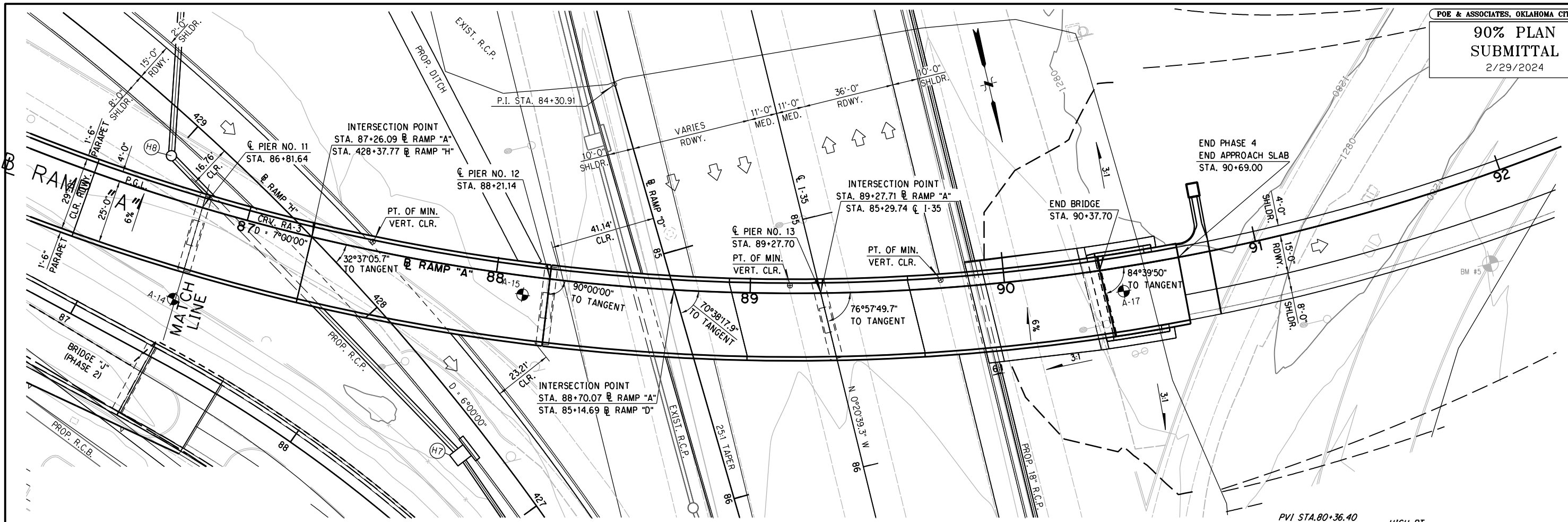

BM 5 - X ON CURB AT CENTER OF INLET
258.21' LT.
@ I-35 STA. 85+81.41 ELEV. 1282.41

BM 6 - CHISELED SQUARE TOP OF EAST
SIDE OF DRAINAGE CANAL 406.13' LT.
@ I-240 STA. 418+82.24 ELEV. 1265.30

CURVE DATA RA-3
SEE ROADWAY SHEETS:
"GEOMETRIC COORDINATE POINT
TABLES" FOR CURVE DATA.

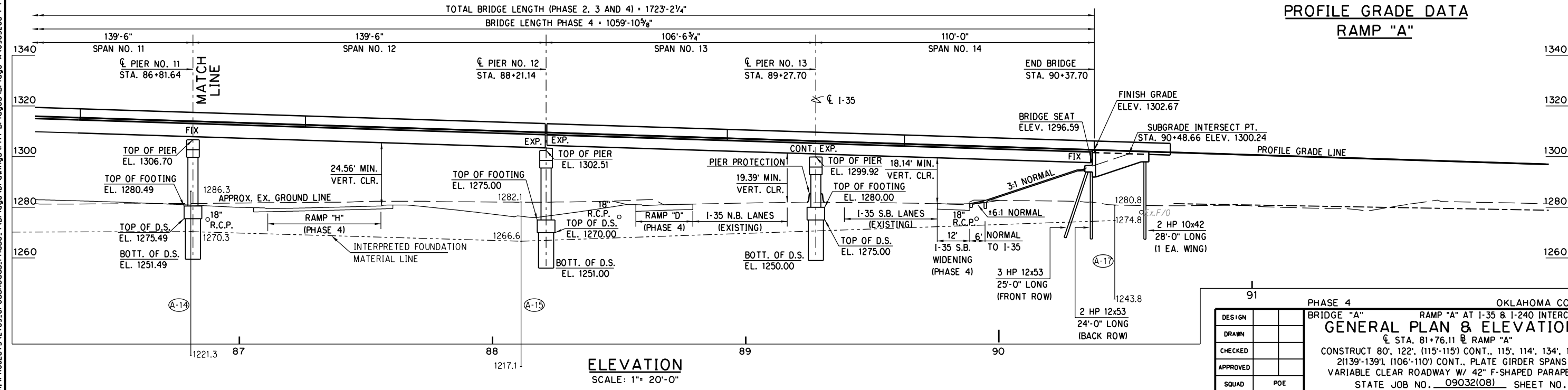
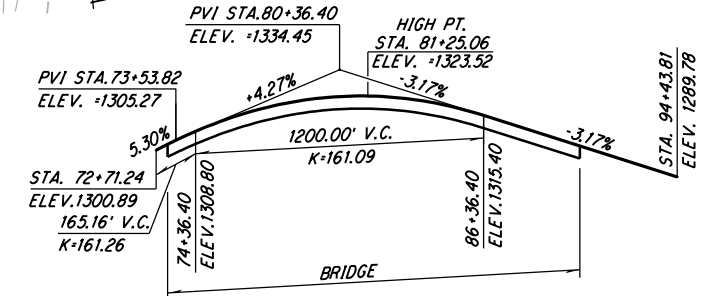
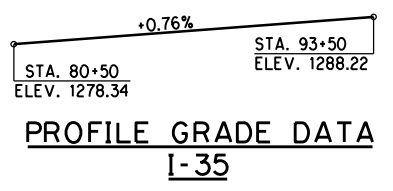

DESIGN		PHASE 4	OKLAHOMA COUNTY
DRAWN		BRIDGE "A"	
CHECKED		GENERAL PLAN & ELEVATION	
APPROVED		@ STA. 81+76.11 @ RAMP "A"	
SQUAD	POE	CONSTRUCT 80', 122', (115'-115') CONT., 115', 114', 134', 151', 2(139'-139'), (106'-110') CONT., PLATE GIRDER SPANS VARIABLE CLEAR ROADWAY W/ 42" F-SHAPED PARAPET STATE JOB NO. 090321081 SHEET NO. B004	

3/1/2024 3:19:42 PM H:\PROJECTS\2789_CrossRoads_Phase 4\Bridges\Drawings\Ph4 Bridges\Bridges\A\0903208 P4 Bridge A GPE.dgn

Boring Number A-09
Northing: 143035.76
Easting: 2151413.36
Date Drilled: 5/18/2017

Boring Number A-10
Northing: 143042.88
Easting: 2151437.24
Date Drilled: 9/19/2017

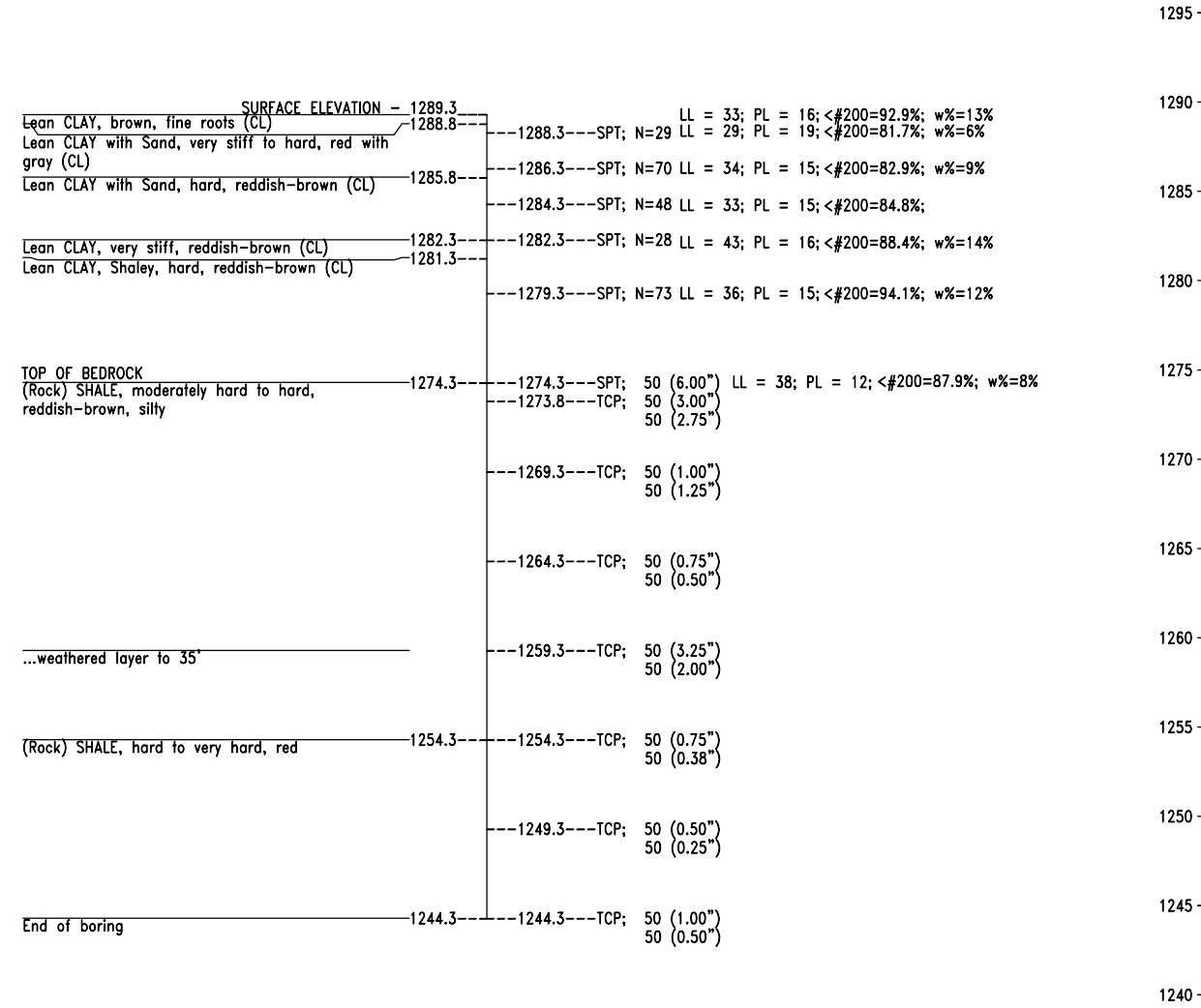
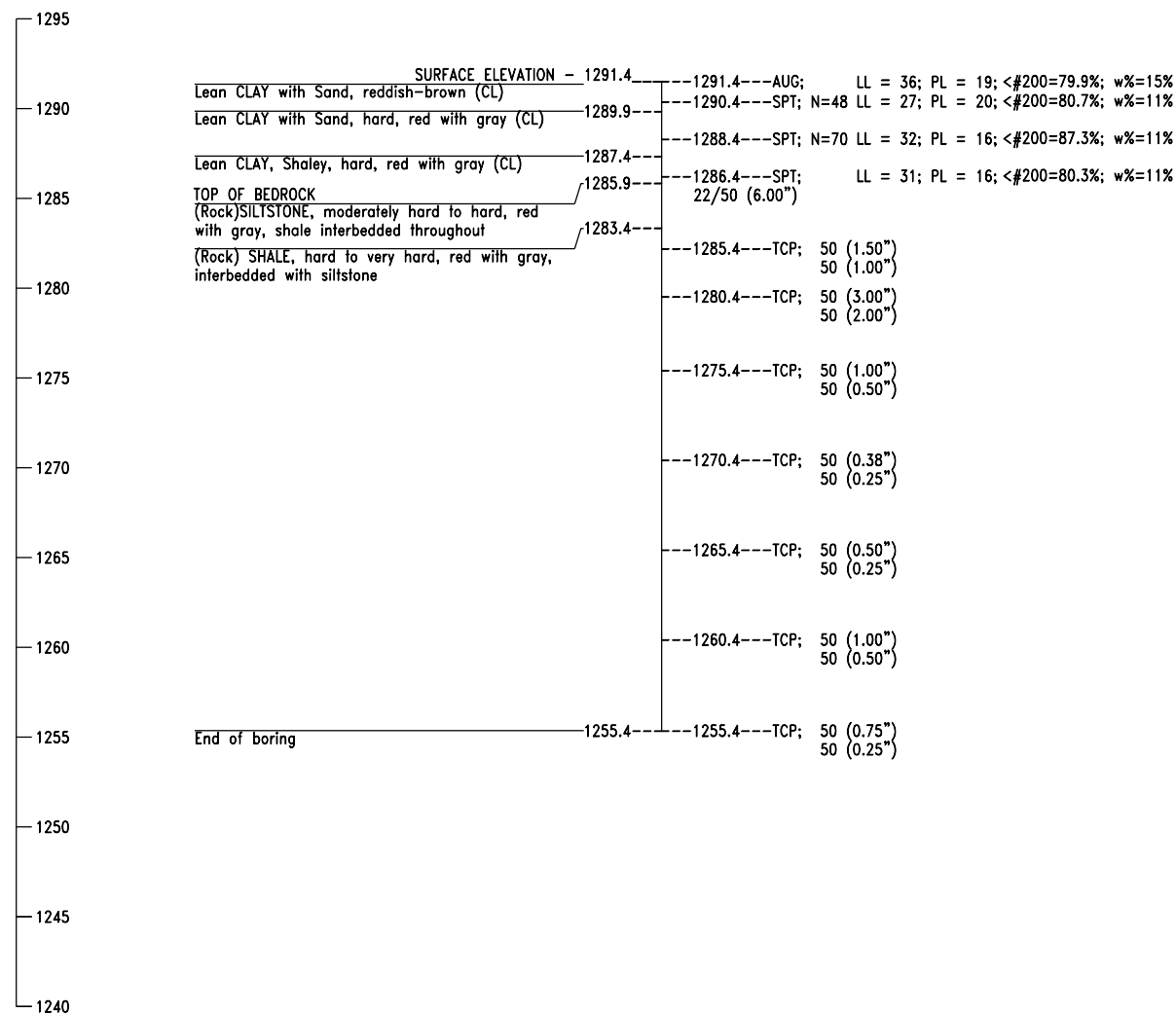

GEOLOGIC STATEMENT

"Division Four" of the "Engineering Classification of Geological Materials", published by the Oklahoma Department of Transportation (ODOT) indicates that the site is underlain by the Hennessey Unit (Phy). The geologic unit is described below.
This unit consists of red platy to blocky clay shales and mudstone. The mudstones are hard and appear blocky. The red clay shale of the Hennessey Unit is characterized by numerous bands of streaks of white or light green color ranging from a few inches to four feet in thickness.
The total thickness of the unit is about 400 feet.
The Hennessey Unit outcrops in a 5- to 15-mile north-south band across Grant, Garfield, Kingfisher, Logan, Canadian, and Oklahoma Counties in Division Four. Topographically, the unit is near level to gently rolling and is generally grass covered or cultivated.

GEOTECHNICAL REPORT

All geotechnical information contained on this sheet is covered by the engineering seal affixed to an original geotechnical engineering report that has been stamped and sealed by a professional engineer licensed in Oklahoma. To obtain a copy of the complete report, contact the ODOT office engineer at (405) 521-2625. The contractor should be fully aware of the site conditions prior to beginning work. Any additional geotechnical information which may be desired is the responsibility of the contractor.

Note: Water level elevations shown were obtained at the time the borings were drilled and may fluctuate throughout the year.

NOTE: SPT - Split Spoon Sampling
TCP - Texas Cone Penetrator Test
AUG - Augur Cutting Sample
LL - Liquid Limit
PL - Plastic Limit

<#200 - Percent passing #200 sieve
w% - Moisture content
N - Number of blows per 12 inches
▽ Denotes depth to observed groundwater

3/1/2024 3:19:47 PM H:\PROJECTS\21789_CrossRoads_Phase 4\Bridges\Drawings\Ph4 Bridges\Bridges A\0903208 P4 Bridge A FR-bor.es.dgn

PHASE 4		OKLAHOMA COUNTY	
DESIGN		BRIDGE "A"	RAMP "A" AT I-35 & I-240 INTERCHANGE
DRAWN		FOUNDATION REPORT (SHEET 1 OF 4)	
CHECKED			
APPROVED			
SQUAD	PSI		
STATE JOB NO. 09032(08)		SHEET NO. 0006	

Boring Number A-11
Northing: 143171.50
Easting: 2151348.68
Date Drilled: 9/21/2017

Boring Number A-12
Northing: 143333.92
Easting: 2151223.25
Date Drilled: 2/13/2018

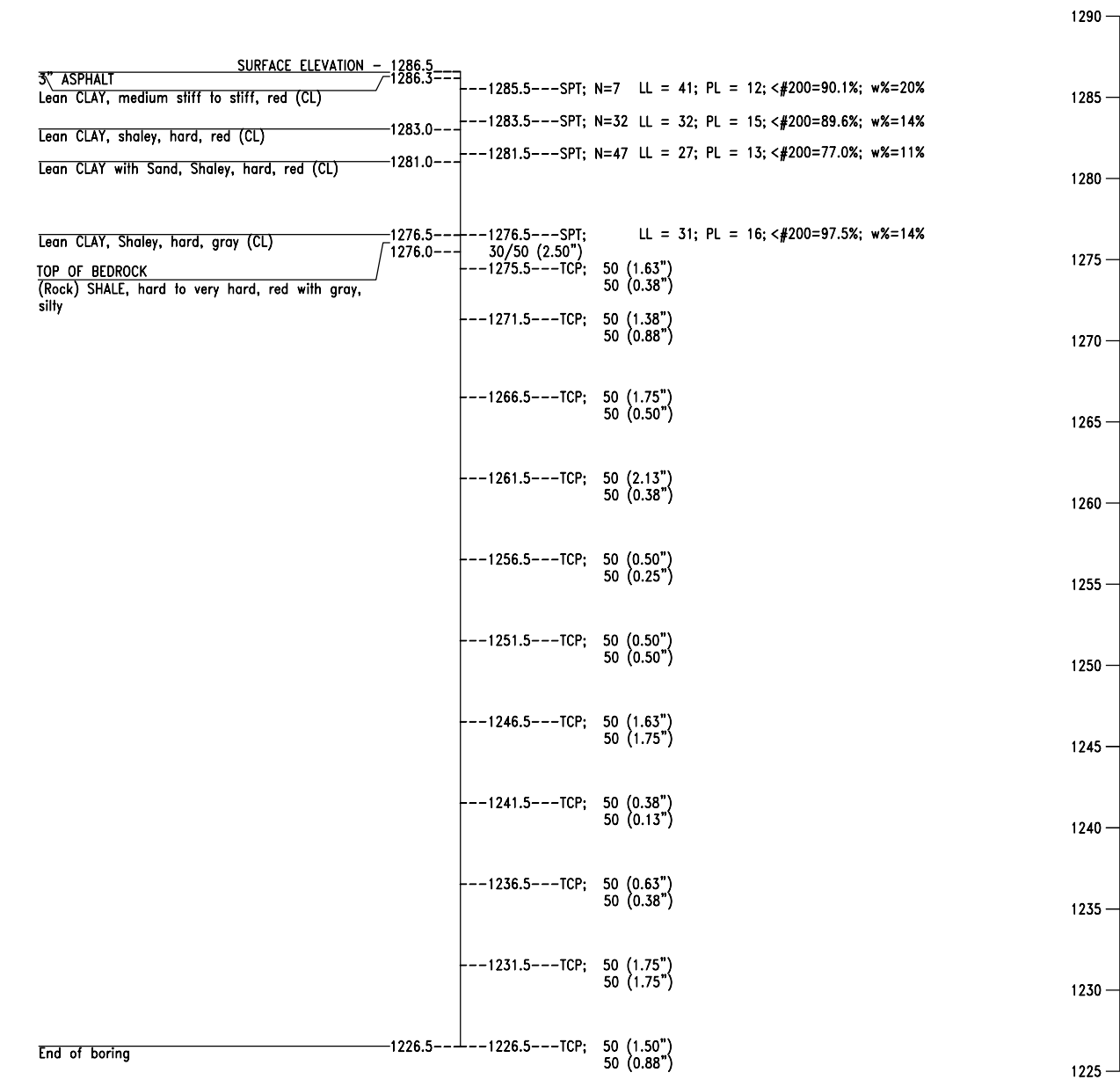
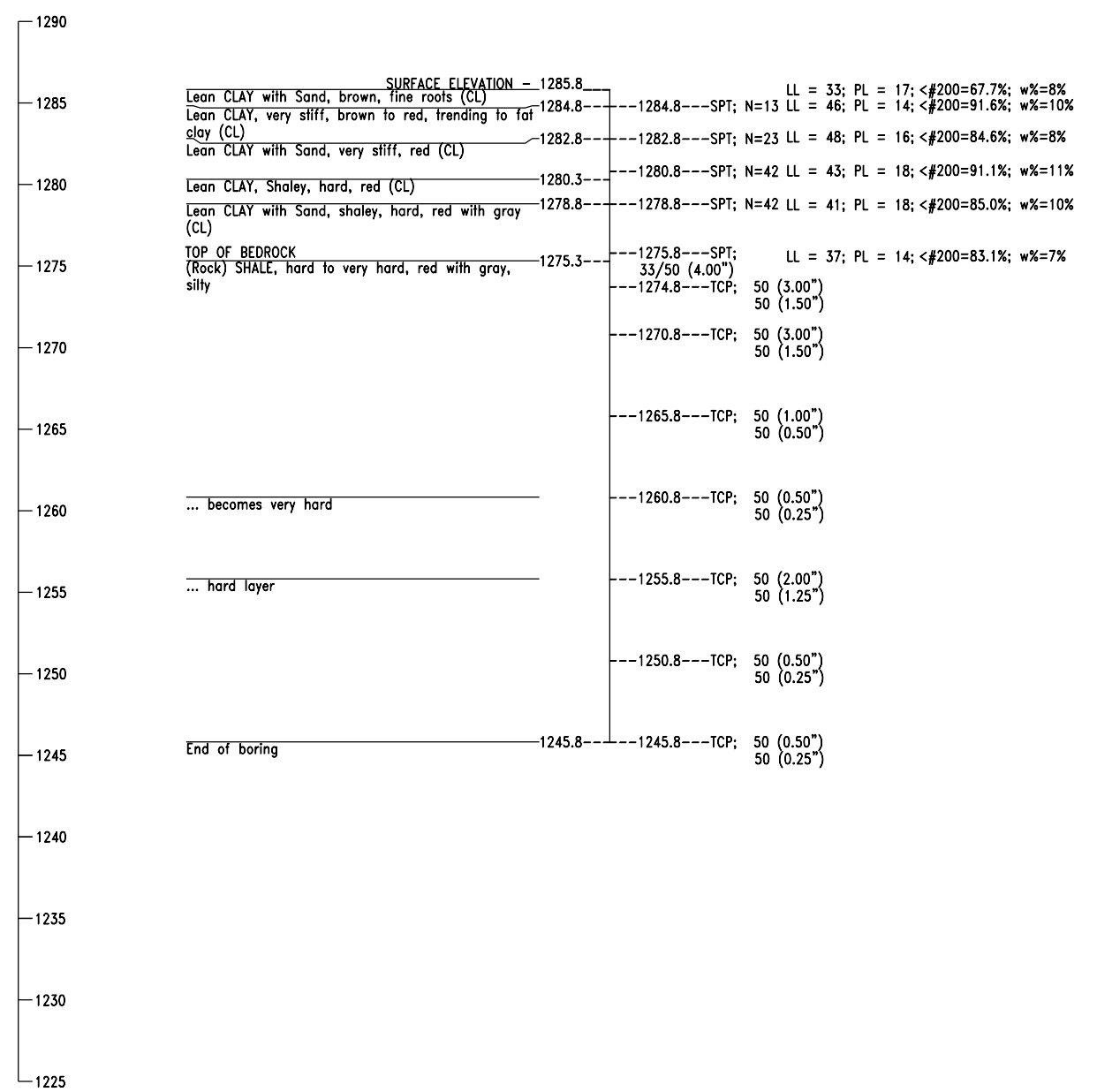

GEOLOGIC STATEMENT

"Division Four" of the "Engineering Classification of Geological Materials", published by the Oklahoma Department of Transportation (ODOT) indicates that the site is underlain by the Hennessey Unit (Phy). The geologic unit is described below.
 This unit consists of red platy to blocky clay shales and mudstone. The mudstones are hard and appear blocky. The red clay shale of the Hennessey Unit is characterized by numerous bands of streaks of white or light green color ranging from a few inches to four feet in thickness.
 The total thickness of the unit is about 400 feet.
 The Hennessey Unit outcrops in a 5- to 15-mile north-south band across Grant, Garfield, Kingfisher, Logan, Canadian, and Oklahoma Counties in Division Four. Topographically, the unit is near level to gently rolling and is generally grass covered or cultivated.

GEOTECHNICAL REPORT

All geotechnical information contained on this sheet is covered by the engineering seal affixed to an original geotechnical engineering report that has been stamped and sealed by a professional engineer licensed in Oklahoma. To obtain a copy of the complete report, contact the ODOT office engineer at (405) 521-2625. The contractor should be fully aware of the site conditions prior to beginning work. Any additional geotechnical information which may be desired is the responsibility of the contractor.

Note: Water level elevations shown were obtained at the time the borings were drilled and may fluctuate throughout the year.

NOTE: SPT - Split Spoon Sampling
 TCP - Texas Cone Penetrator Test
 AUG - Augur Cutting Sample
 LL - Liquid Limit
 PL - Plastic Limit

<#200 - Percent passing #200 sieve
 w% - Moisture content
 N - Number of blows per 12 inches
 ∇ Denotes depth to observed groundwater

PHASE 4		OKLAHOMA COUNTY	
DESIGN		BRIDGE "A"	RAMP "A" AT I-35 & I-240 INTERCHANGE
DRAWN		FOUNDATION REPORT (SHEET 2 OF 4)	
CHECKED			
APPROVED			
SQUAD	PSI		
STATE JOB NO. 09032(08)		SHEET NO. 007	

3/1/2024 3:19:49 PM H:\PROJECTS\21789_CrossRoads_Phase 4\Bridges\Drawings\Ph4 Bridges\Bridges A\0903208 P4 Bridge A FR-bor-01.dgn

Boring Number A-13
Northing: 143427.50
Easting: 2151131.57
Date Drilled: 2/14/2018

Boring Number A-14
Northing: 143492.08
Easting: 2151069.25
Date Drilled: 2/15/2018

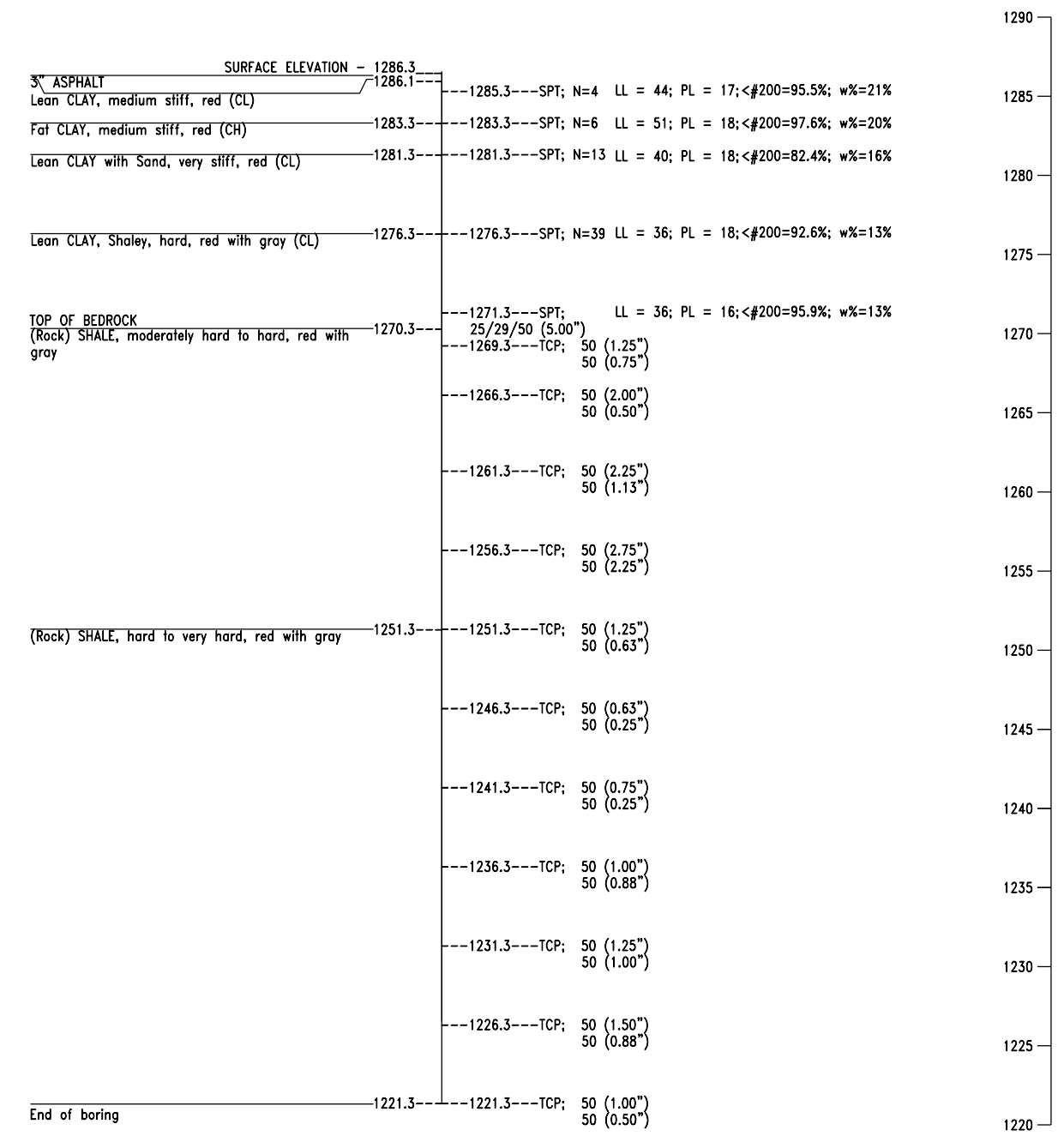
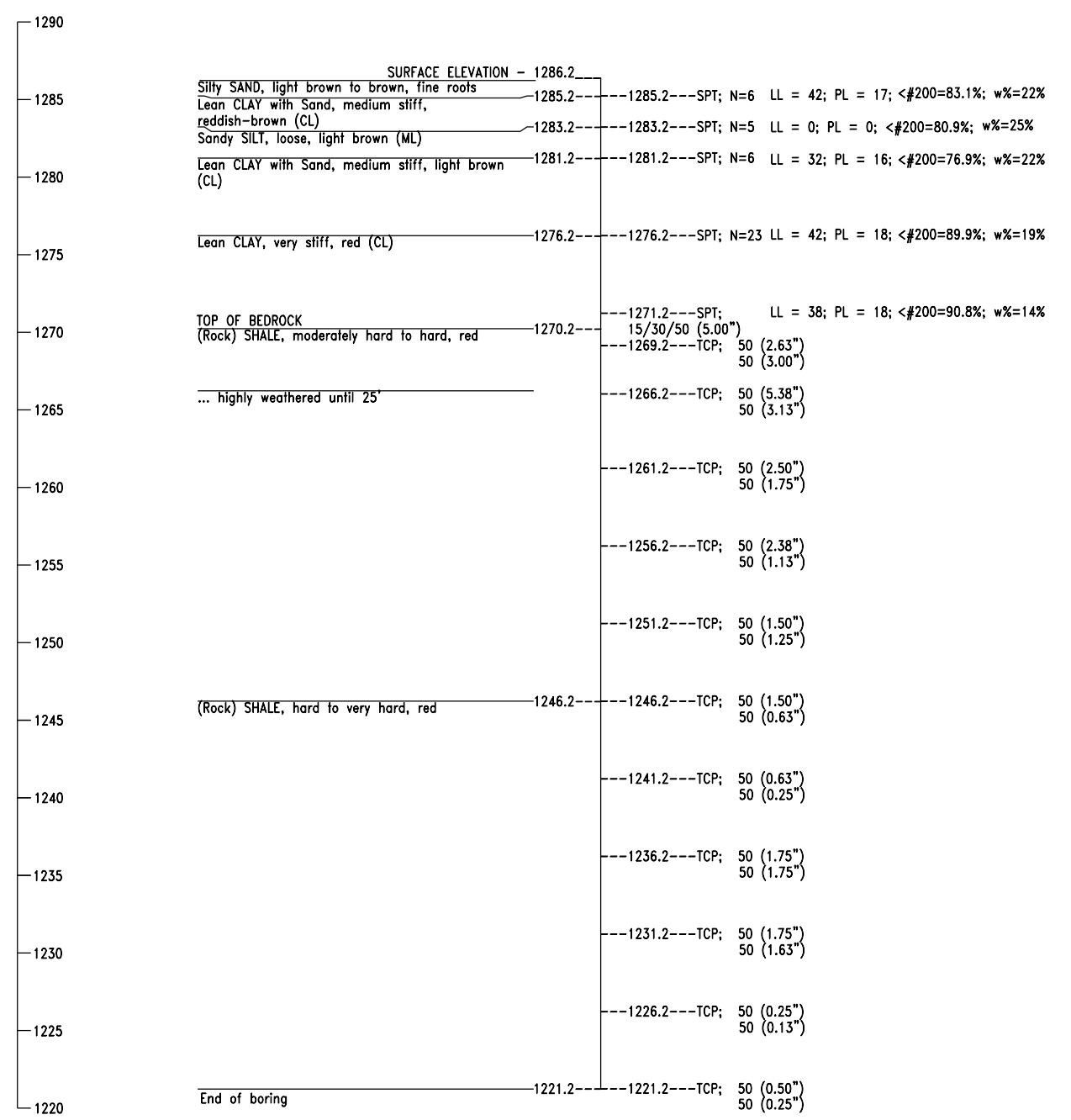

GEOLOGIC STATEMENT

"Division Four" of the "Engineering Classification of Geological Materials", published by the Oklahoma Department of Transportation (ODOT) indicates that the site is underlain by the Hennessey Unit (Phy). The geologic unit is described below.
 This unit consists of red platy to blocky clay shales and mudstone. The mudstones are hard and appear blocky. The red clay shale of the Hennessey Unit is characterized by numerous bands of streaks of white or light green color ranging from a few inches to four feet in thickness.
 The total thickness of the unit is about 400 feet.
 The Hennessey Unit outcrops in a 5- to 15-mile north-south band across Grant, Garfield, Kingfisher, Logan, Canadian, and Oklahoma Counties in Division Four. Topographically, the unit is near level to gently rolling and is generally grass covered or cultivated.

GEOTECHNICAL REPORT

All geotechnical information contained on this sheet is covered by the engineering seal affixed to an original geotechnical engineering report that has been stamped and sealed by a professional engineer licensed in Oklahoma. To obtain a copy of the complete report, contact the ODOT office engineer at (405) 521-2625. The contractor should be fully aware of the site conditions prior to beginning work. Any additional geotechnical information which may be desired is the responsibility of the contractor.

Note: Water level elevations shown were obtained at the time the borings were drilled and may fluctuate throughout the year.

NOTE: SPT - Split Spoon Sampling
 TCP - Texas Cone Penetrator Test
 AUG - Augur Cutting Sample
 LL - Liquid Limit
 PL - Plastic Limit

<#200 - Percent passing #200 sieve
 w% - Moisture content
 N - Number of blows per 12 inches
 ∇ Denotes depth to observed groundwater

3/1/2024 3:19:51 PM H:\PROJECTS\21789_Cr\oseroads_Phase_4\Bridges\Drawings\Ph4 Bridges\Bridg A\0903208 P4 Bridge A FR-bor.es.dgn

PHASE 4		OKLAHOMA COUNTY	
DESIGN		BRIDGE "A"	RAMP "A" AT I-35 & I-240 INTERCHANGE
DRAWN		FOUNDATION REPORT (SHEET 3 OF 4)	
CHECKED			
APPROVED			
SQUAD	PSI		
STATE JOB NO. 09032(08)		SHEET NO. 008	

Boring Number A-15
Northing: 143522.33
Easting: 2150935.41
Date Drilled: 2/15/2018

Boring Number A-17
Northing: 143575.89
Easting: 2150705.44
Date Drilled: 5/23/2017

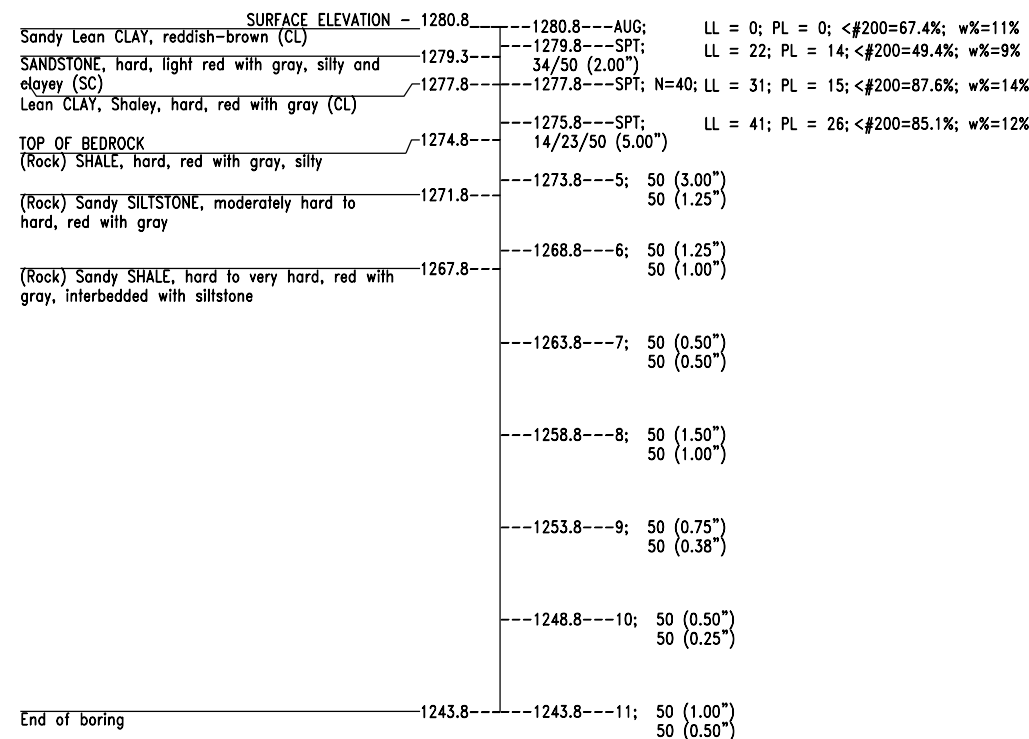
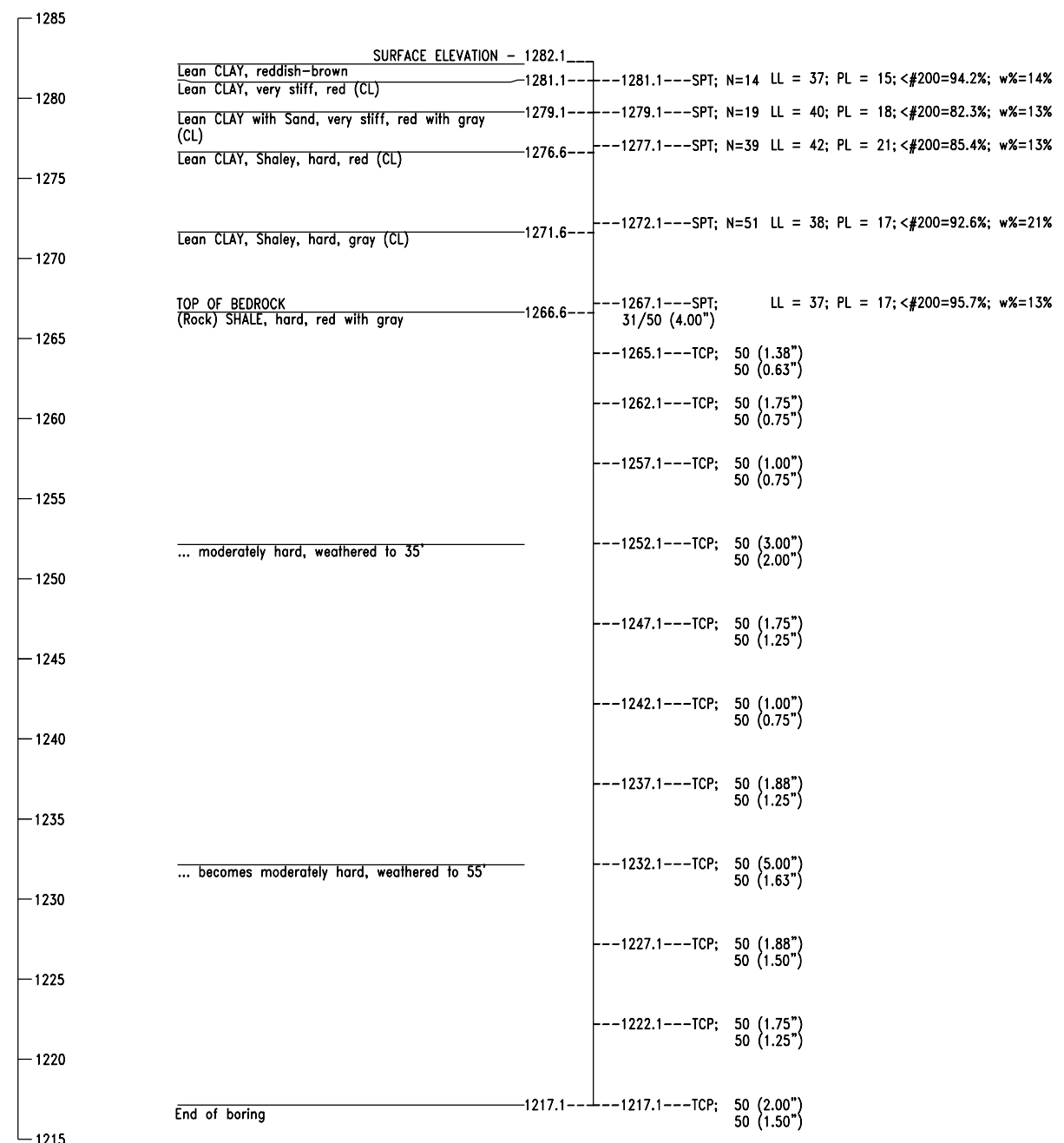

GEOLOGIC STATEMENT

"Division Four" of the "Engineering Classification of Geological Materials", published by the Oklahoma Department of Transportation (ODOT) indicates that the site is underlain by the Hennessey Unit (Phy). The geologic unit is described below.
 This unit consists of red platy to blocky clay shales and mudstone. The mudstones are hard and appear blocky. The red clay shale of the Hennessey Unit is characterized by numerous bands of streaks of white or light green color ranging from a few inches to four feet in thickness.
 The total thickness of the unit is about 400 feet.
 The Hennessey Unit outcrops in a 5- to 15-mile north-south band across Grant, Garfield, Kingfisher, Logan, Canadian, and Oklahoma Counties in Division Four. Topographically, the unit is near level to gently rolling and is generally grass covered or cultivated.

GEOTECHNICAL REPORT

All geotechnical information contained on this sheet is covered by the engineering seal affixed to an original geotechnical engineering report that has been stamped and sealed by a professional engineer licensed in Oklahoma. To obtain a copy of the complete report, contact the ODOT office engineer at (405) 521-2625. The contractor should be fully aware of the site conditions prior to beginning work. Any additional geotechnical information which may be desired is the responsibility of the contractor.

Note: Water level elevations shown were obtained at the time the borings were drilled and may fluctuate throughout the year.

NOTE: SPT - Split Spoon Sampling
 TCP - Texas Cone Penetrator Test
 AUG - Augur Cutting Sample
 LL - Liquid Limit
 PL - Plastic Limit

<#200 - Percent passing #200 sieve
 w% - Moisture content
 N - Number of blows per 12 inches
 ▽ Denotes depth to observed groundwater

3/1/2024 3:19:53 PM H:\PROJECTS\21789_Cr\os\roads_Phase_4\Bridges\Drawings\Ph4 Bridges\Bridges\A\0903208 P4 Bridge A FR-bor.es.dgn

PHASE 4		OKLAHOMA COUNTY	
DESIGN		BRIDGE "A"	RAMP "A" AT I-35 & I-240 INTERCHANGE
DRAWN		FOUNDATION REPORT (SHEET 4 OF 4)	
CHECKED			
APPROVED			
SQUAD	PSI	STATE JOB NO. 09032(08)	SHEET NO. 009

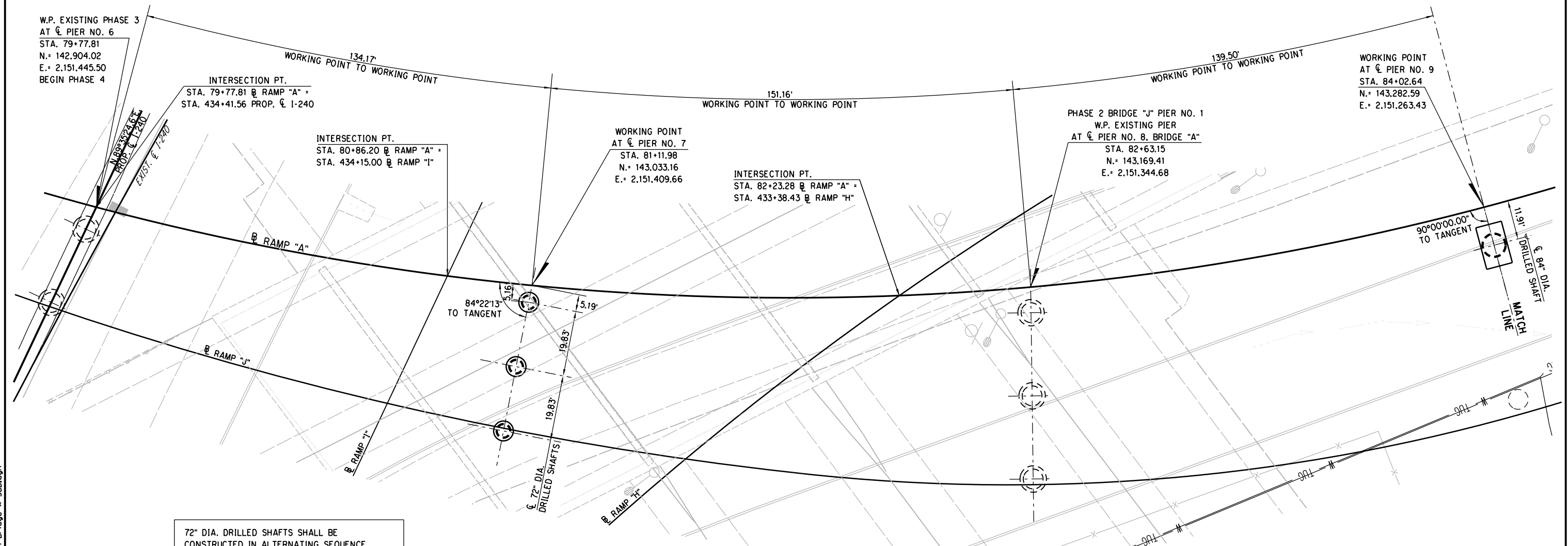

72" DIA. DRILLED SHAFTS SHALL BE CONSTRUCTED IN ALTERNATING SEQUENCE. DRILLED SHAFTS THAT ARE ADJACENT TO EACH OTHER SHALL NOT BE CONSTRUCTED IN THE SAME SEQUENCE. DO NOT EXCAVATE FOR ADJACENT DRILLED SHAFTS UNTIL THE PRIOR SEQUENCE OF SHAFTS HAS BEEN POURED AND ATTAINED A COMPRESSIVE STRENGTH OF 3 KSI.



SUBSTRUCTURE STAKING DIAGRAM

UTILITIES:
(CAUTION) THE LOCATION OF ALL UTILITIES AS SHOWN ARE APPROXIMATE DUE TO RELOCATION PLANNED OR PRESENTLY UNDER CONSTRUCTION. THERE ARE SOME UTILITIES THAT WILL BE RELOCATED AND NOT SHOWN ON THESE PLANS. THE CONTRACTOR SHALL BE RESPONSIBLE FOR ANY DAMAGE TO ALL UTILITIES. NO PAYMENT WILL BE MADE FOR REMOVAL OF ABANDONED UTILITY PIPE LINES THAT INTERFERE WITH CONSTRUCTION. ALL COST TO BE INCLUDED IN OTHER ITEMS.

OKLAHOMA ONE-CALL SYSTEM:
IN ACCORDANCE WITH THE OKLAHOMA UNDERGROUND FACILITIES DAMAGE PREVENTION ACT THE CONTRACTOR SHALL NOTIFY THE OKLAHOMA ONE-CALL SYSTEM, INC. 48 HOURS PRIOR TO BEGINNING EXCAVATION. OKLAHOMA ONE-CALL SYSTEM, INC. "CALL OKIE" 1-800-522-6543 OR 811.

DRILLED SHAFT CONSTRUCTION:
DUE TO THE VERY HARD ROCK ENCOUNTERED AT THIS SITE, DRILLED SHAFT EXCAVATIONS WILL REQUIRE SPECIALIZED ROCK DRILLING EQUIPMENT. THE CONTRACTOR IS RESPONSIBLE FOR BECOMING FAMILIAR WITH THE EXISTING SUBSURFACE CONDITIONS AND THEIR IMPLICATIONS ON THE DRILLING PROCESSES PRIOR TO BEGINNING WORK.

PHASE 4		OKLAHOMA COUNTY	
DESIGN		BRIDGE "A"	RAMP "A" AT I-35 & I-240 INTERCHANGE
DRAWN		SUBSTRUCTURE LAYOUT (SHEET 1 OF 2)	
CHECKED			
APPROVED			
SQUAD	POE	STATE JOB NO. 09032(08) SHEET NO. B010	

3/1/2024 3:19:56 PM H:\PROJECTS\2789_CrossRoads_Phase 4\Bridges\Drawings\Ph4 Bridges\Bridg A SUB.dgn

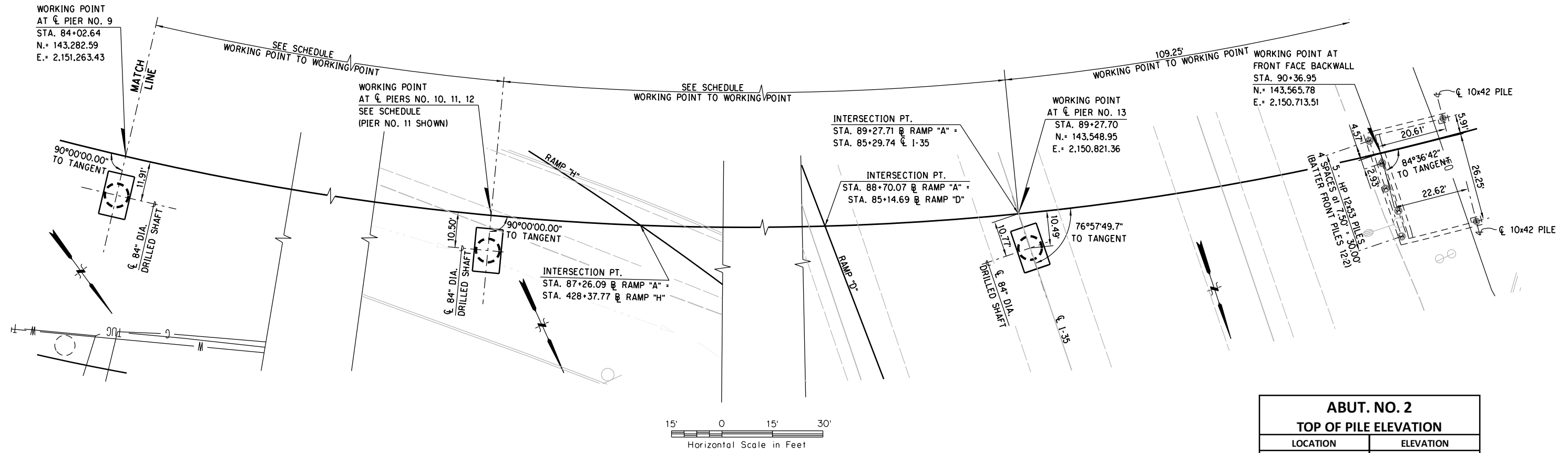

SUBSTRUCTURE STAKING DIAGRAM

ABUT. NO. 2 TOP OF PILE ELEVATION	
LOCATION	ELEVATION
SEAT	1294.93
WING	1298.93

PIER LOCATION SCHEDULE			
LOCATION	WORKING POINT STA.	NORTHING	EASTING
PIER NO. 9	84+02.64	143,282.59	2,151,263.43
PIER NO. 10	85+42.10	143,380.97	2,151,164.17
PIER NO. 11	86+81.64	143,459.88	2,151,049.75
PIER NO. 12	88+21.14	143,518.84	2,150,923.51
PIER NO. 13	89+27.70	143,548.95	2,150,821.36

WORKING PT. TO WORKING PT. SCHEDULE	
LOCATION	WP. TO W.P. DISTANCE
PIER NO. 9 TO PIER NO. 10	139.46'
PIER NO. 10 TO PIER NO. 11	139.54'
PIER NO. 11 TO PIER NO. 12	139.50'
PIER NO. 12 TO PIER NO. 13	139.50'

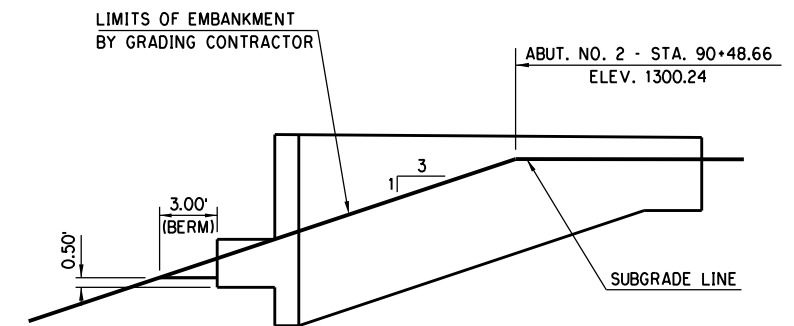

DETAIL OF GRADING AT ABUTMENT

3/1/2024 3:05:57 PM H:\PROJECTS\2189_CrossRoads_Phase_4\Bridge\Drawings\Ph4_Bridges\Bridge A\0903208 P4 Bridge A SUB.dgn

DESIGN		PHASE 4	OKLAHOMA COUNTY
DRAWN		BRIDGE "A"	RAMP "A" AT I-35 & I-240 INTERCHANGE
CHECKED		<p align="center">SUBSTRUCTURE LAYOUT (SHEET 2 OF 2)</p>	
APPROVED			
SQUAD			
POE		STATE JOB NO. 09032108	SHEET NO. B011

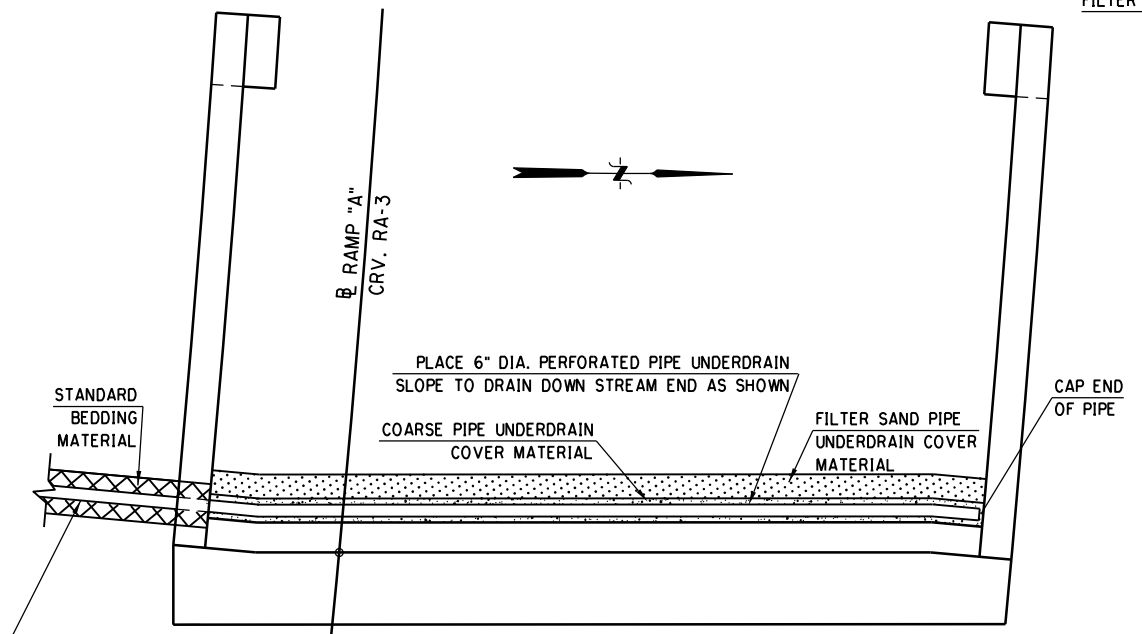

PIPE UNDERDRAIN PLAN

PLACE 6" DIA. NON-PERFORATED PIPE UNDERDRAIN. EXTEND TO TOE OF SLOPE, DITCH OR DRAINAGE STRUCTURE. ACTUAL LENGTH AND LOCATION TO BE DETERMINED IN THE FIELD BY THE ENGINEER.

NOTE:
CONCRETE MAY BE PLACED AGAINST THE LIMITS OF EXCAVATION IF THE MATERIAL IS EXCAVATED TO THE NEAT LINES OF THE ABUTMENT AND APPROVED BY THE ENGINEER. IF NECESSARY, FORMS SHALL BE USED ON THE BACK VERTICAL FACE OF THE ABUTMENT AND REMOVED AFTER CONCRETE IS SET.
MEASUREMENT AND PAYMENT FOR SUBSTRUCTURE EXCAVATION COMMON SHALL BE ACCORDANCE WITH THE DIAGRAM SHOWN ON THE PLANS.

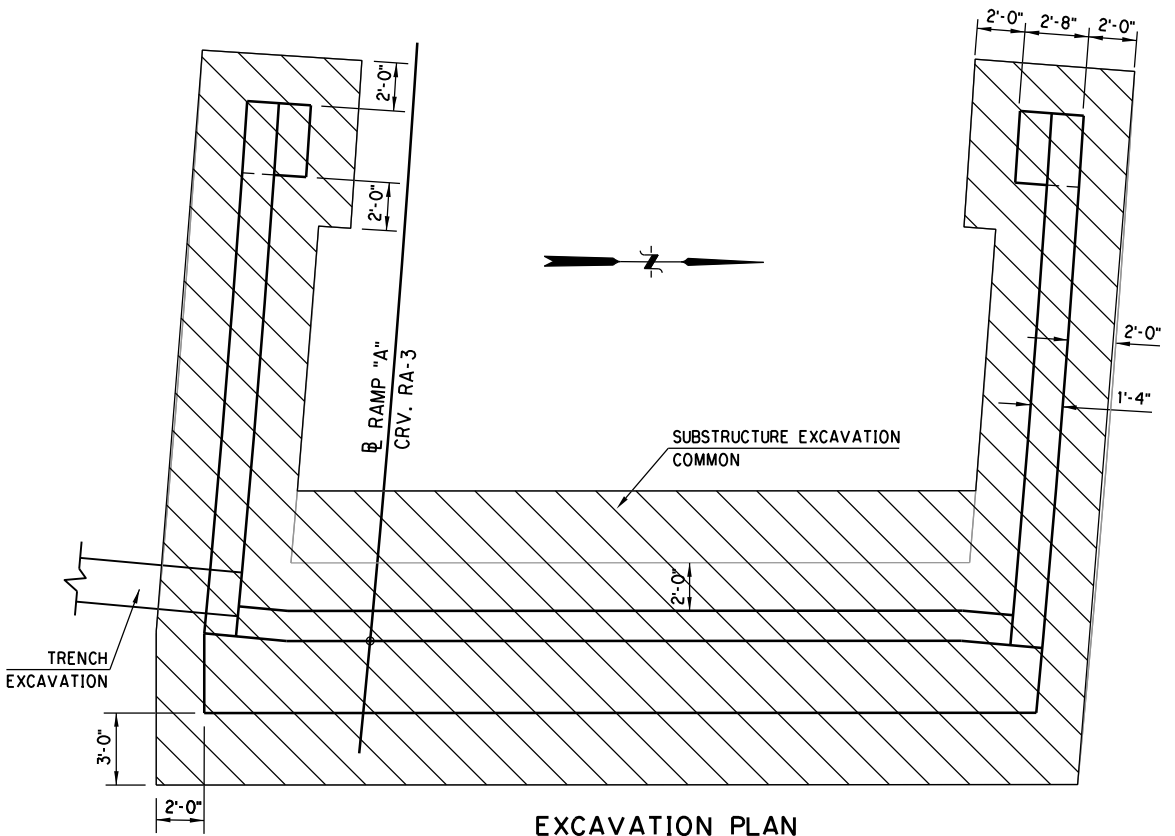

EXCAVATION PLAN

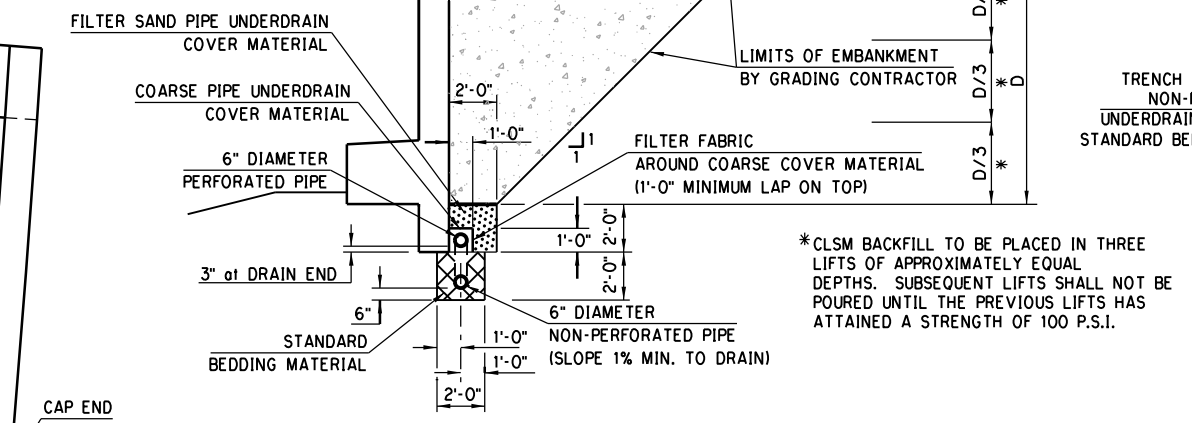

UNDERDRAIN INSTALLATION DETAIL

* CLSM BACKFILL TO BE PLACED IN THREE LIFTS OF APPROXIMATELY EQUAL DEPTHS. SUBSEQUENT LIFTS SHALL NOT BE POURED UNTIL THE PREVIOUS LIFTS HAS ATTAINED A STRENGTH OF 100 P.S.I.

① GRADE LINE SHOWN IS ASSUMED TO BE LOCATED 12" BELOW BOTTOM OF APPROACH SLAB FOR COMPUTING CLSM BACKFILL QUANTITY SHOWN ON THE PLANS. THE DEPARTMENT WILL PAY FOR CLSM BACKFILL IN ACCORDANCE WITH THE PLAN QUANTITY AND NO ADJUSTMENT WILL BE MADE FOR ACTUAL LOCATION OF GRADE LINE.

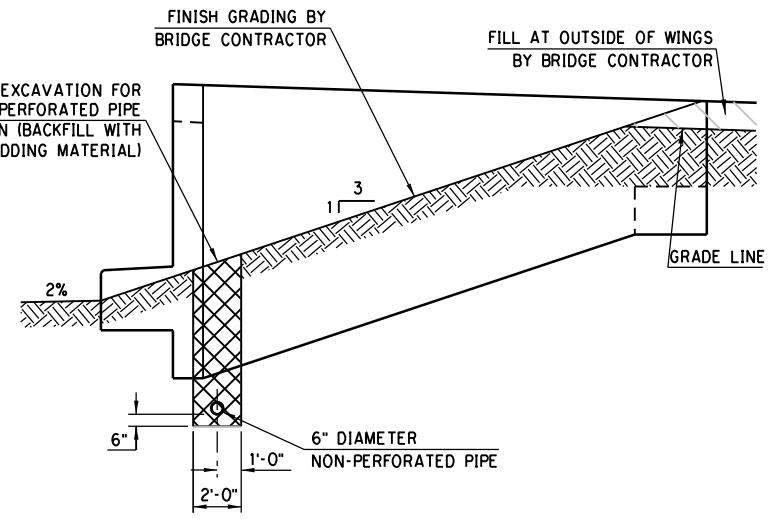

BACKFILL DETAIL OUTSIDE OF WING

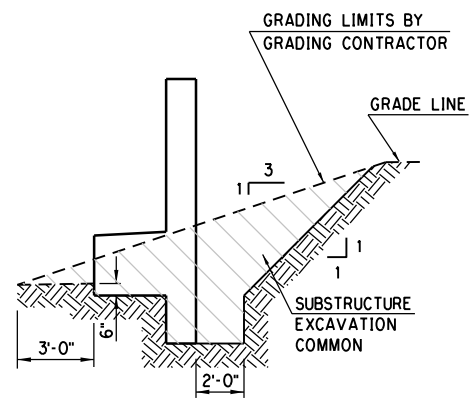

SECTION THRU BRIDGE SEAT

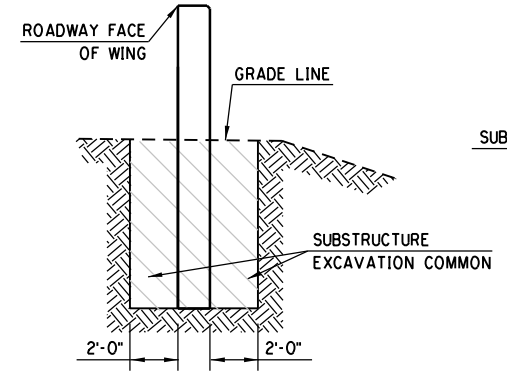

SECTION A-A
SECTION THRU WING

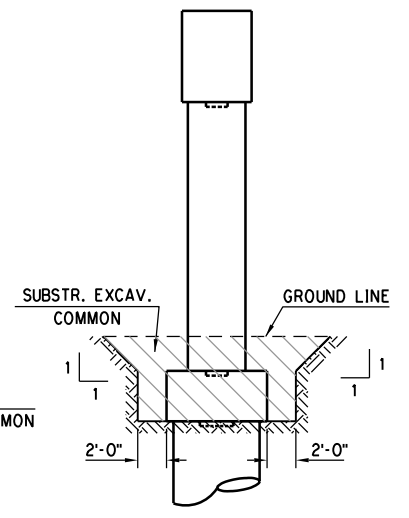

PIER EXCAVATION
DIAGRAM
(TYPICAL)

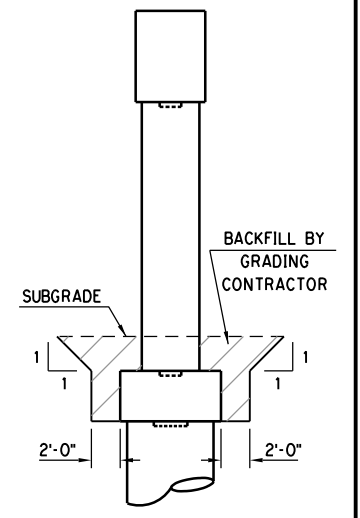

PIER BACKFILL
DIAGRAM
(TYPICAL)

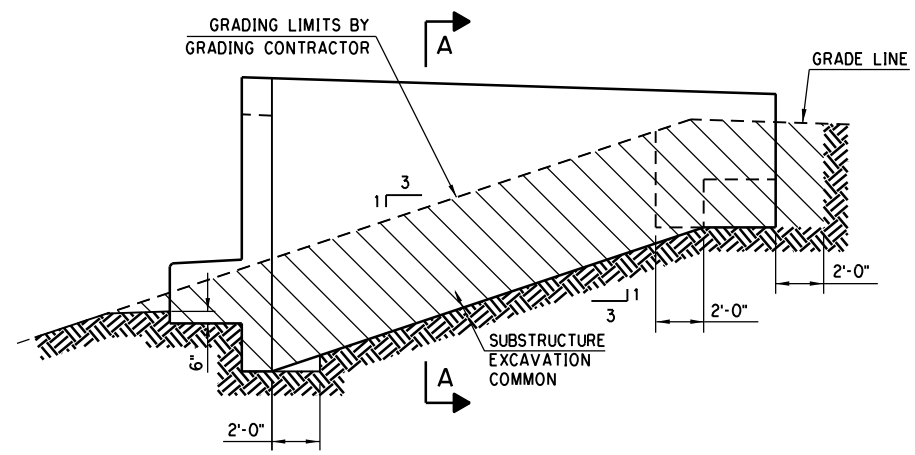

WING ELEVATION

ABUTMENT EXCAVATION DIAGRAMS

CONSTRUCTION NOTES

1. CLSM BACKFILL SHALL NOT BE PLACED UNTIL THE SUPERSTRUCTURE IS IN PLACE AND THE ABUTMENT WING CONCRETE HAS ATTAINED A STRENGTH OF 3000 P.S.I.
2. INSTALLATION OF THE PIPE UNDERDRAIN SHALL BE AS SHOWN IN THE PLANS AND ON ODOT STD. PUD-4 AND SPI-5. THE EXTENT, LOCATION AND DEPTH OF THE 6" NON-PERFORATED PIPE UNDERDRAIN WILL BE DETERMINED BY THE ENGINEER TO SUIT CONDITIONS FOUND DURING CONSTRUCTION.
3. COST OF ALL MATERIALS, EQUIPMENT, LABOR AND INCIDENTALS NEEDED FOR THE INSTALLATION OF UNDERDRAIN PIPE SHALL BE INCLUDED IN THE UNIT PRICE BID FOR "6" PERFORATED PIPE UNDERDRAIN ROUND" AND "6" NON-PERF. PIPE UNDERDRAIN RND".
4. FOR ADDITIONAL DETAILS FOR PIPE UNDERDRAIN INSTALLATION, SEE ODOT STDS. PUD-4 AND SPI-5.

PHASE 4		OKLAHOMA COUNTY	
DESIGN		BRIDGE "A"	RAMP "A" AT I-35 & I-240 INTERCHANGE
DRAWN			
CHECKED			
APPROVED			
SQUAD	POE		
		EXCAVATION DIAGRAMS AND UNDERDRAIN DETAILS	
		STATE JOB NO. 09032(08) SHEET NO. B012	

3/1/2024 3:19:59 PM H:\PROJECTS\2789_CrossRoads_Phase 4\Bridges\Drawings\Ph4 Bridges\Bridges\A\0903208 P4 Bridge A AbutExcav.dgn

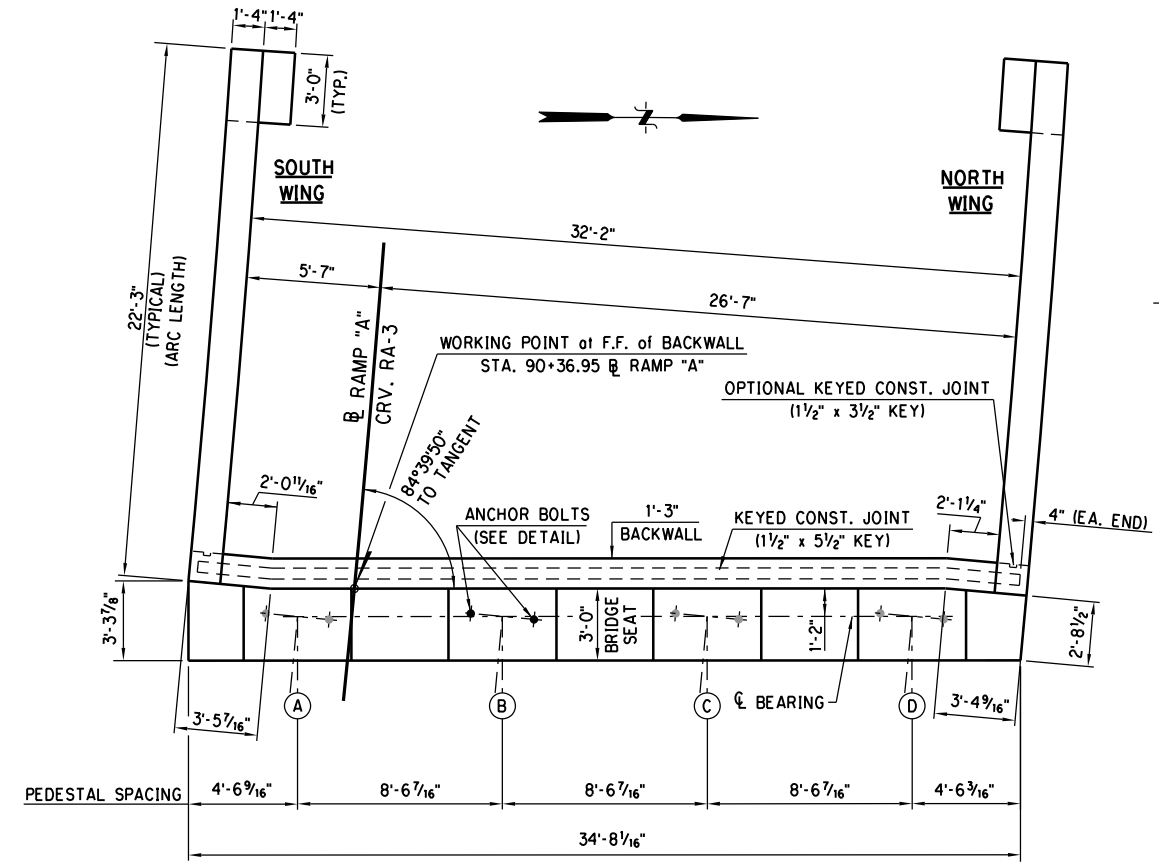

PLAN

PEDESTAL ELEVATION SCHEDULE - ABUTMENT				
PEDESTAL	A	B	C	D
ELEVATION	1296.84	1297.33	1297.81	1298.30
DEPTH	3"	8 7/8"	14 5/8"	20 1/2"

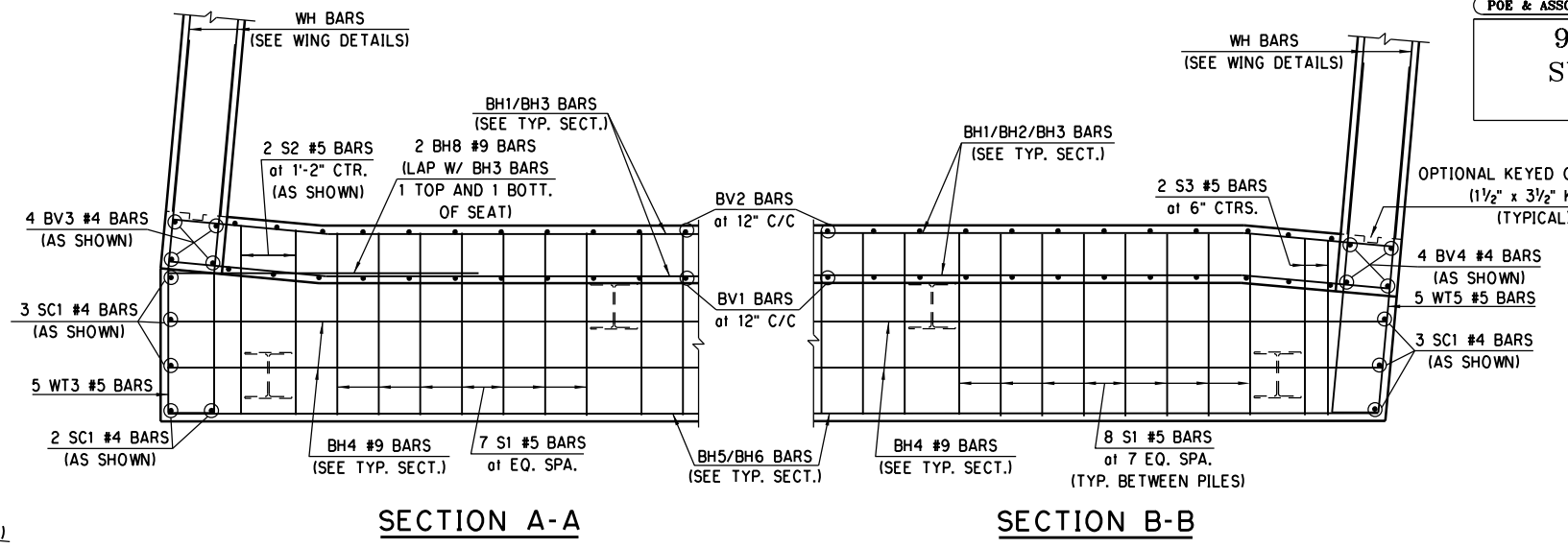

SECTION A-A

SECTION B-B

NOTE: DIMENSIONS SHOWN ARE PERPENDICULAR TO PEDESTALS.
FOR FURTHER INFORMATION SEE "BEARING ASSEMBLY DETAILS" SHEET.

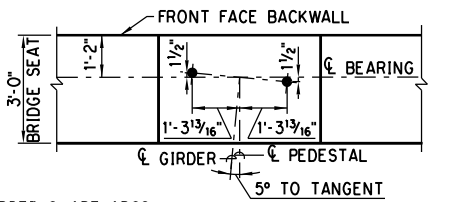

NOTE: GIRDER C ARE ARCS.
EACH PEDESTAL C IS CONGRUENT WITH ITS GIRDER C AT THE C BEARING

ANCHOR BOLT LAYOUT DETAIL
(TYPICAL)

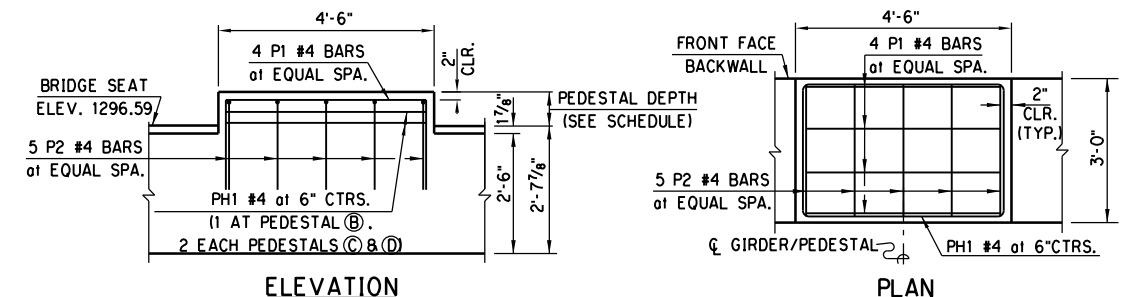

ELEVATION

PLAN

PEDESTAL REINFORCING DETAILS
(TYPICAL)

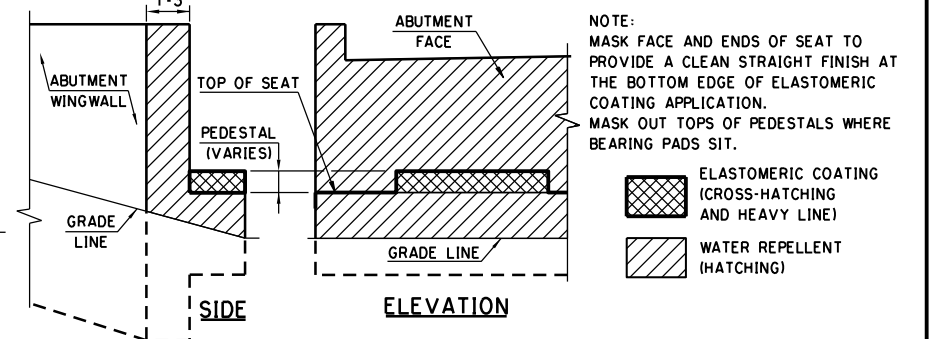

SIDE

ELEVATION

CONCRETE TREATMENT DETAILS

NOTE: MASK FACE AND ENDS OF SEAT TO PROVIDE A CLEAN STRAIGHT FINISH AT THE BOTTOM EDGE OF ELASTOMERIC COATING APPLICATION. MASK OUT TOPS OF PEDESTALS WHERE BEARING PADS SIT.

- ELASTOMERIC COATING (CROSS-HATCHING AND HEAVY LINE)
- WATER REPELLENT (HATCHING)

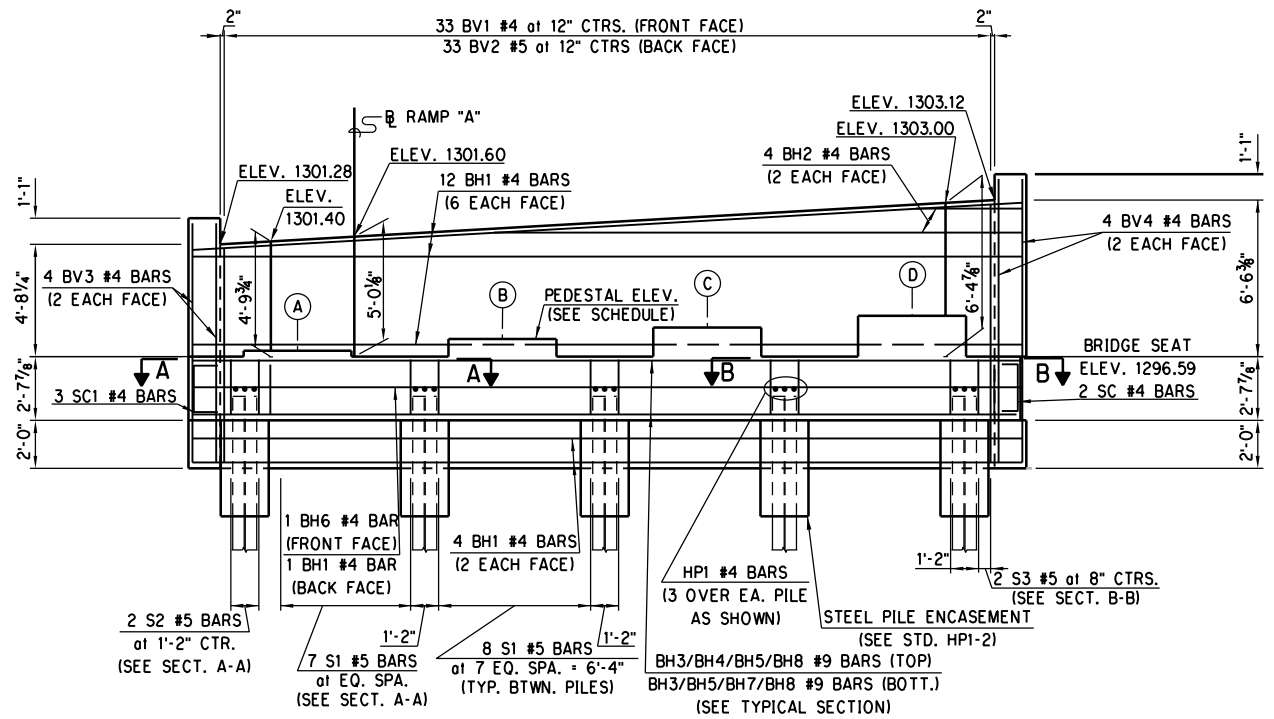

ELEVATION

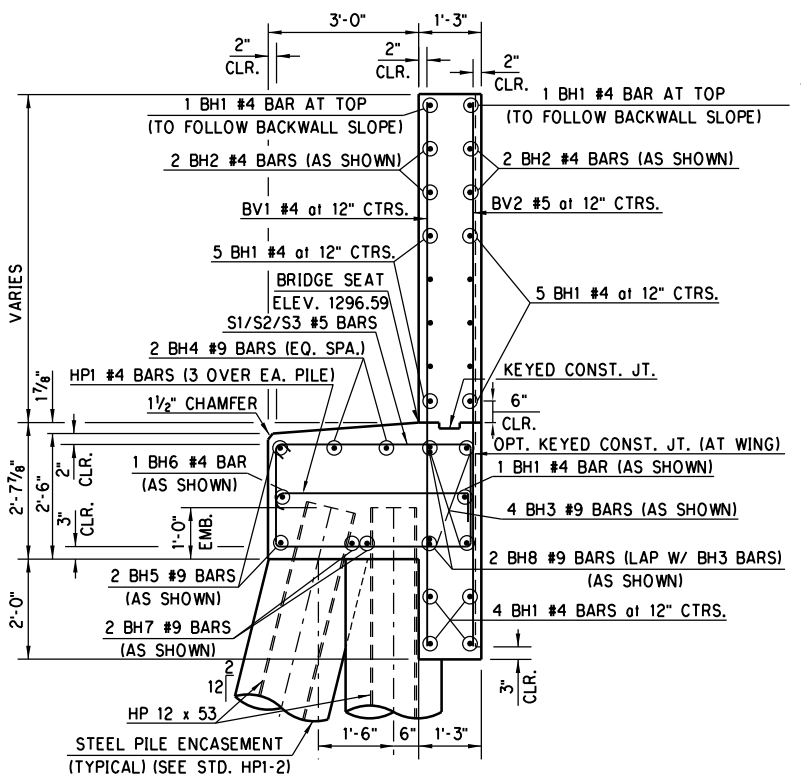

TYPICAL SECTION THRU BRIDGE SEAT
(PEDESTAL NOT SHOWN)

ABUTMENT QUANTITIES		
ITEM	UNIT	TOTAL
SUBSTRUCTURE EXCAVATION COMMON	C.Y.	80.00
CLSM BACKFILL	C.Y.	97.50
CLASS A CONCRETE	C.Y.	50.70
EPOXY COATED REINFORCING STEEL	LB.	5,440.00
PILES, FURNISHED (HP 12x53)	L.F.	123.00
PILES, DRIVEN (HP 12x53)	L.F.	123.00
PILES, FURNISHED (HP 10x42)	L.F.	56.00
PILES, DRIVEN (HP 10x42)	L.F.	56.00
WATER REPELLENT (VISUALLY INSPECTED)	S.Y.	32.00
ELASTOMERIC COATING	S.F.	148.00
6" PERFORATED PIPE UNDERDRAIN, ROUND	L.F.	33.00
6" NON-PERF. PIPE UNDERDRAIN, RND.	L.F.	20.00

DESIGN	
DRAWN	
CHECKED	
APPROVED	
SQUAD	POE

3/1/2024 3:20:01 PM H:\PROJECTS\2789_Crossroads_Phase 4\Bridges\Drawings\Phase 4\Bridges\Bridges\Abutment\0903208 P4 Bridge A Abut.dgn

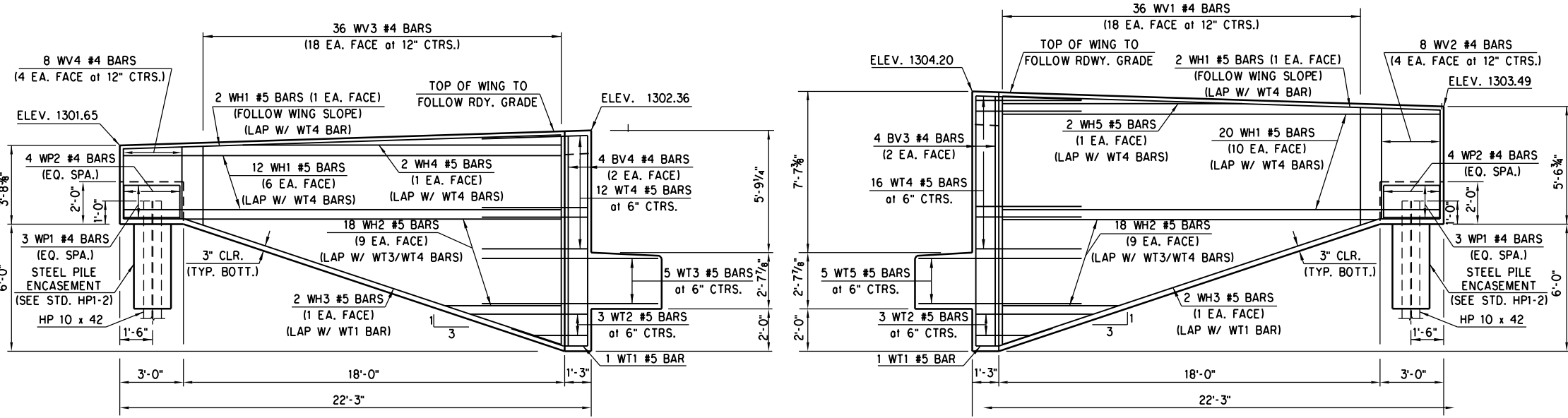

SOUTH WING ELEVATION

NORTH WING ELEVATION

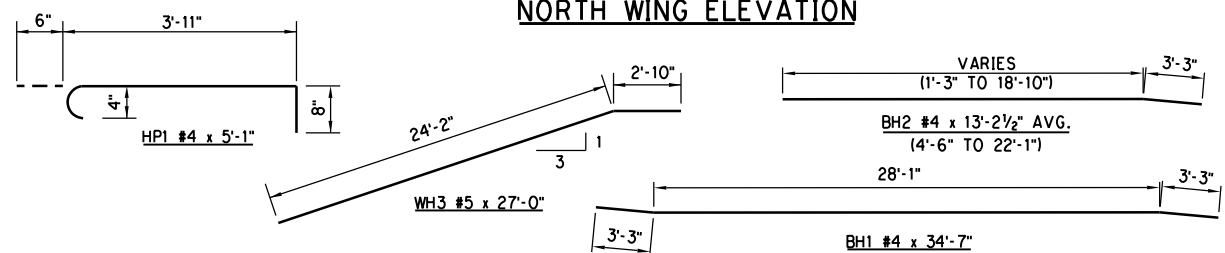

ABUTMENT BAR LIST (EPOXY COATED)

MARK	NO.	SIZE	FORM	SPACING	LENGTH	LENGTH VARIATION
BH1	17	#4	BENT	12" C/C	34'-7"	--
BH2	4	#9	BENT	AS SHOWN	13'-3 1/2" AVG.	4'-6" TO 22'-1"
BH3	4	#9	BENT	AS SHOWN	34'-7"	--
BH4	2	#9	STR.	EQUAL	34'-6 1/2" AVG.	34'-6" TO 34'-7"
BH5	2	#9	STR.	AS SHOWN	34'-4"	--
BH6	1	#4	STR.	AS SHOWN	34'-4"	--
BH7	2	#9	STR.	AS SHOWN	34'-6"	--
BH8	2	#9	STR.	AS SHOWN	6'-3"	--
BV1	33	#4	STR.	12" C/C	9'-10" AVG.	8'-11" TO 10'-9"
BV2	33	#5	STR.	12" C/C	9'-10" AVG.	8'-11" TO 10'-9"
BV3	4	#4	STR.	AS SHOWN	9'-11"	--
BV4	4	#5	STR.	AS SHOWN	11'-9"	--
HP1	15	#4	BENT	AS SHOWN	5'-1"	--
P1	16	#4	BENT	EQUAL	8'-2"	--
P2	20	#4	BENT	EQUAL	6'-8"	--
PH1	5	#4	BENT	AS SHOWN	14'-8"	--
S1	31	#5	BENT	EQUAL	12'-11"	--
S2	2	#5	BENT	6" C/C	13'-2" AVG.	12'-2" TO 14'-2"
S3	2	#5	BENT	14" C/C	11'-9" AVG.	11'-8" TO 11'-10"
SC1	7	#4	BENT	EQUAL	3'-5"	--
WT1	2	#5	BENT	AS SHOWN	8'-6"	--
WT2	6	#5	BENT	6" C/C	9'-0" AVG.	6'-0" TO 12'-0"
WT3	5	#5	BENT	6" C/C	16'-3"	--
WT4	28	#5	BENT	6" C/C	11'-0"	--
WT5	5	#5	BENT	6" C/C	16'-3"	--
WH1	28	#5	STR.	6" C/C	20'-8"	--
WH2	36	#5	STR.	6" C/C	11'-7 1/2" AVG.	5'-6" TO 17'-9"
WH3	4	#5	BENT	AS SHOWN	21'-9"	--
WH4	4	#5	STR.	6" C/C	11'-8 1/2" AVG	7'-0" TO 16'-5"
WH5	2	#5	STR.	AS SHOWN	11'-7"	--
WP1	6	#4	BENT	EQUAL	8'-8"	--
WP2	8	#4	STR.	EQUAL	1'-7"	--
WV1	36	#4	STR.	12" C/C	6'-9 1/2" AVG.	3'-9" TO 9'-10"
WV2	8	#4	STR.	12" C/C	3'-4 1/2" AVG.	3'-4" TO 3'-5"
WV3	36	#4	STR.	12" C/C	8'-7 1/2" AVG.	5'-7" TO 11'-8"
WV4	8	#4	STR.	12" C/C	5'-2 1/2" AVG.	5'-2" TO 5'-3"

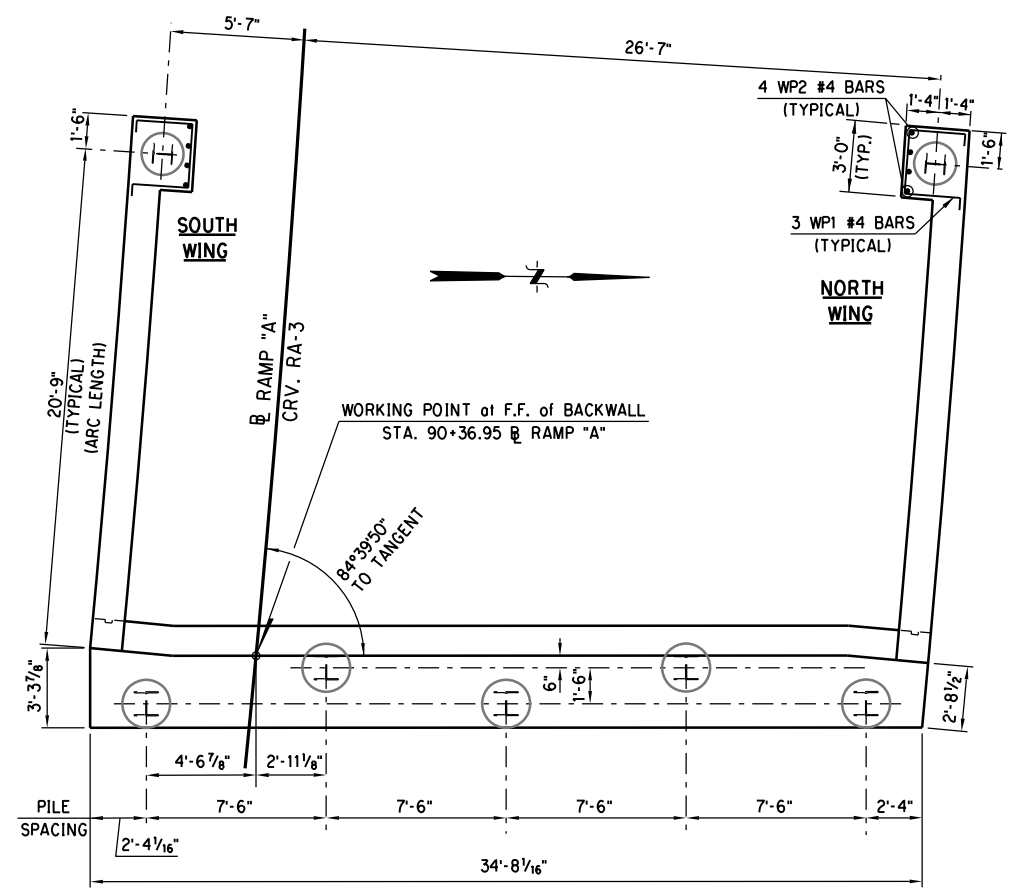

PILE SPACING DIAGRAM

NOTE: BR. SEAT PILES ARE HP 12 x 53. WING PILES ARE HP 10 x 42 (BATTER FRONT ROW IN BR. SEAT 2:12)

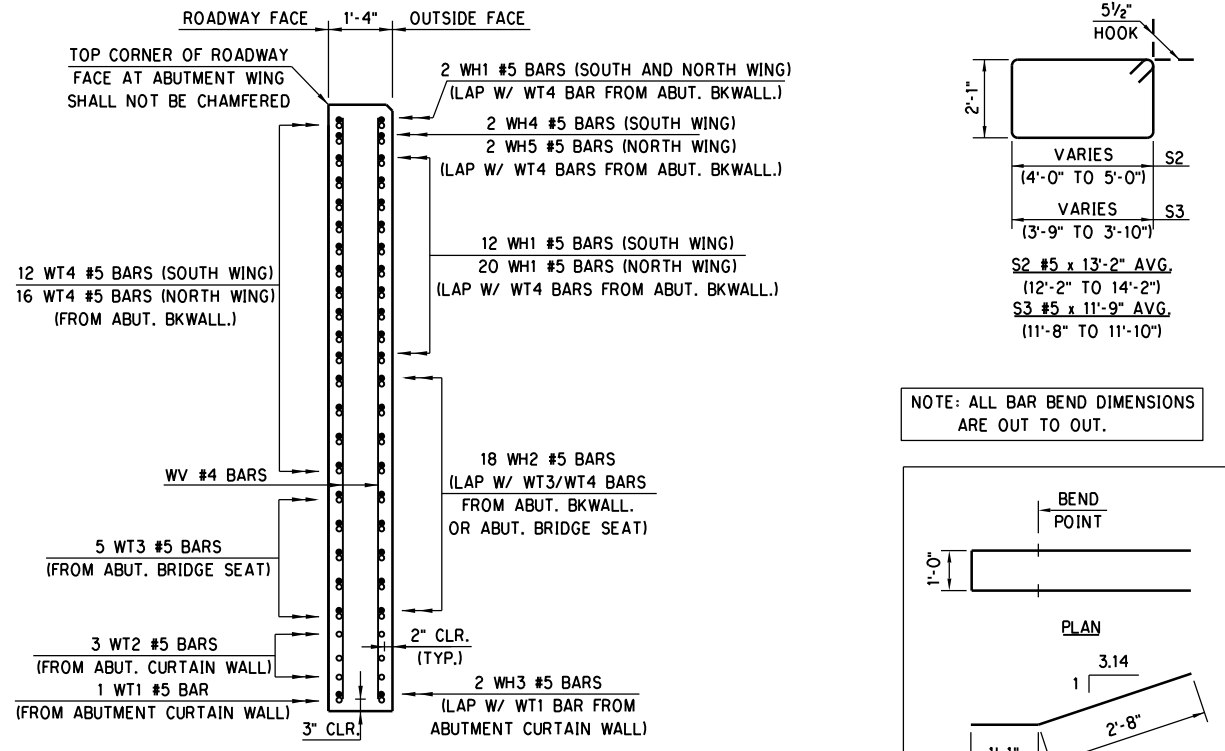

SECTION THRU WING AT BACK FACE OF ABUTMENT SEAT (NORTH WING SHOWN)

NOTE: ALL BAR BEND DIMENSIONS ARE OUT TO OUT.

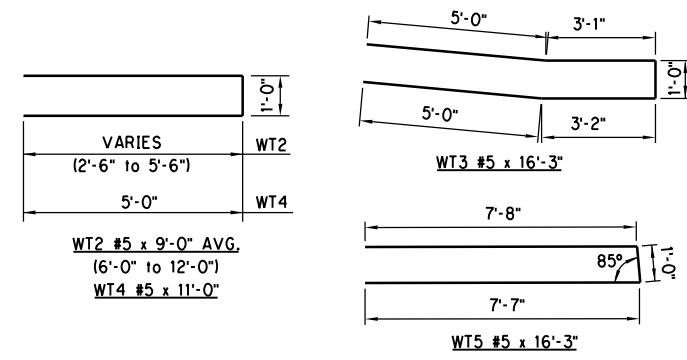
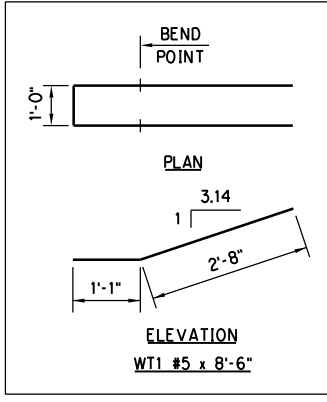

DESIGN		PHASE 4		OKLAHOMA COUNTY	
DRAWN		BRIDGE "A"		RAMP "A" AT I-35 & I-240 INTERCHANGE	
CHECKED				ABUTMENT DETAILS	
APPROVED				(SHEET 2 OF 2)	
SQUAD	POE	STATE JOB NO. 09032(08)		SHEET NO. B014	

3/1/2024 3:20:03 PM H:\PROJECTS\2789_CrossRoads_Phase 4\Bridges\Drawings\Ph4 Bridges\Bridges A\0903208 P4 Bridge A Abut.dgn

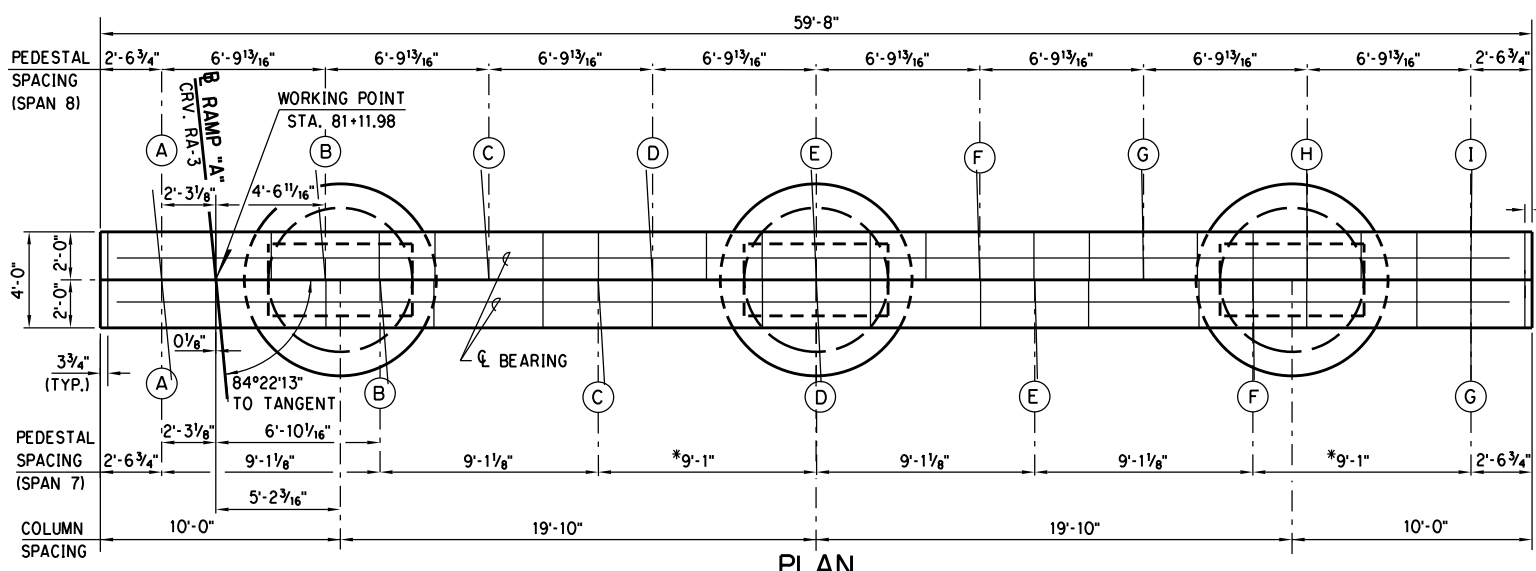

PLAN
(SEE SHEET 3 OF 3
FOR ANCHOR BOLT LAYOUTS)

*SPAN NO. 7 GIRDERS ARE
AT 9'-1 1/8" CTRS. AT CL PIER.

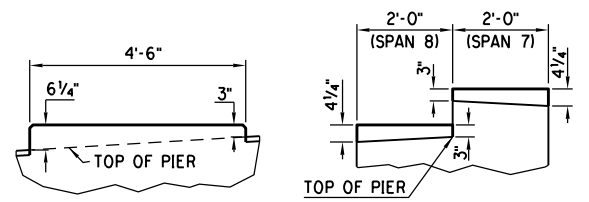

ELEVATION WEST END VIEW
PEDESTAL DETAIL
(TYPICAL)

PEDESTAL	A	B	C	D	E	F	G	H	I
SPAN 7 ELEVATION	1316.63	1317.17	1317.71	1318.25	1318.80	1319.34	1319.88	--	--
SPAN 8 ELEVATION	1315.90	1316.31	1316.72	1317.12	1317.53	1317.94	1318.34	1318.75	1319.16

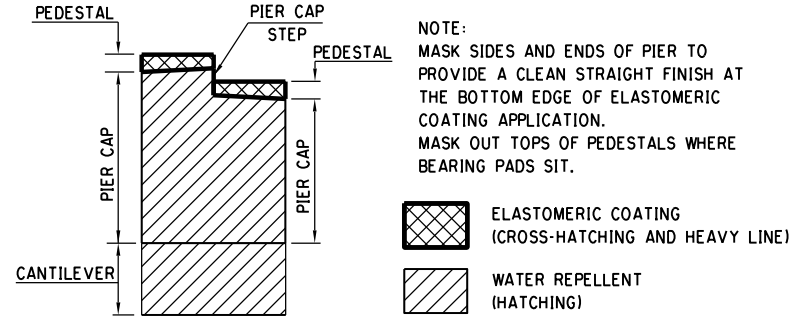

CONCRETE TREATMENT DETAILS

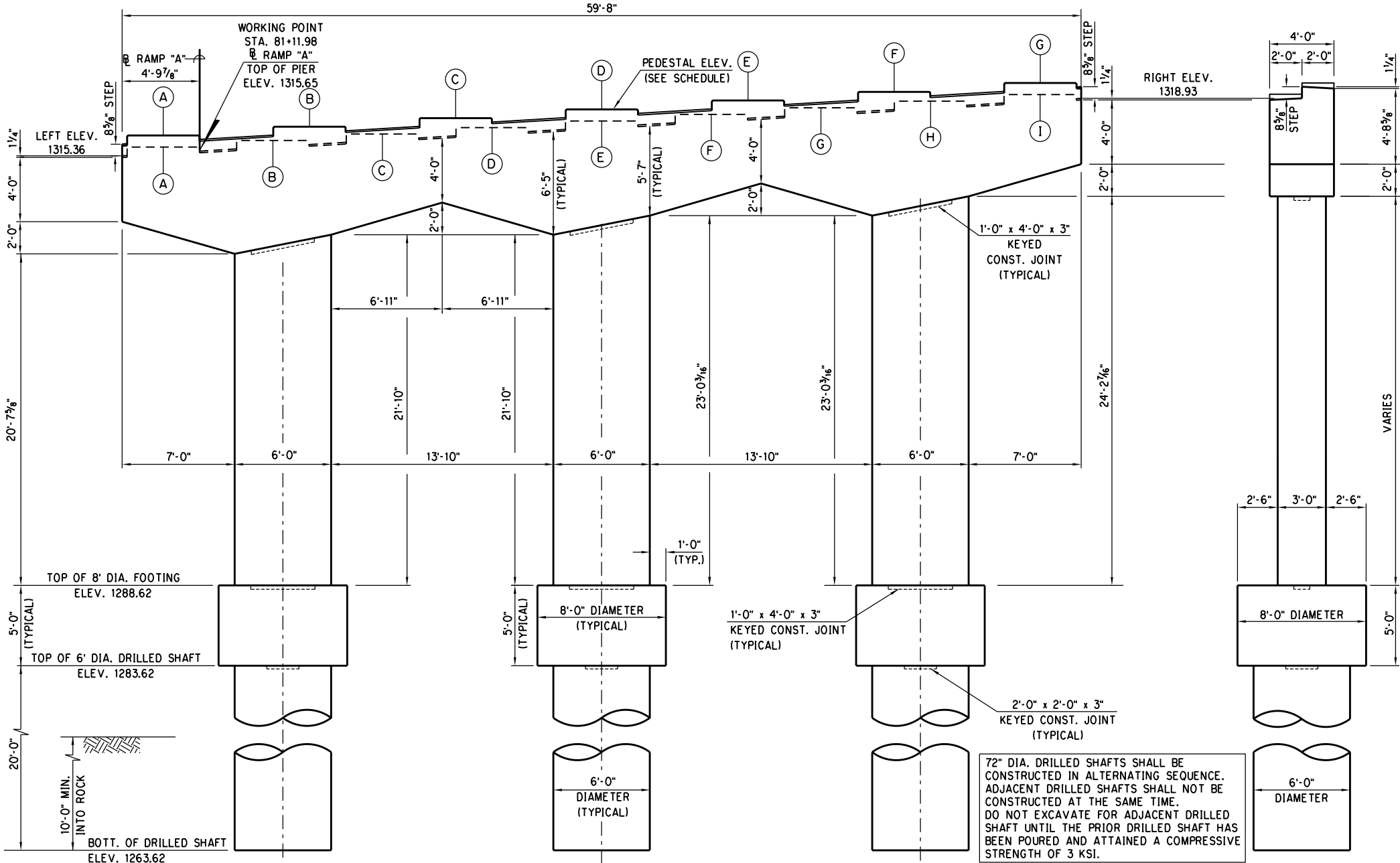

ELEVATION

WEST END VIEW

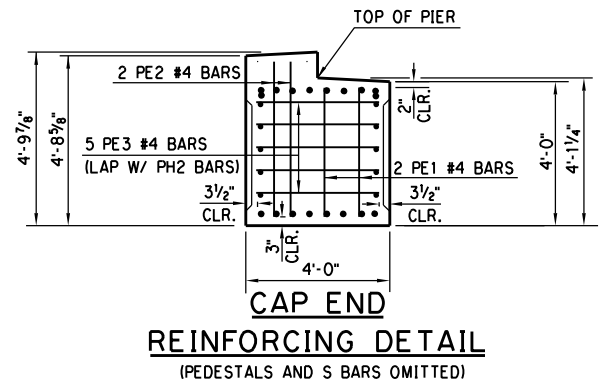

CAP END REINFORCING DETAIL
(PEDESTALS AND S BARS OMITTED)

ITEM	UNIT	TOTAL
SUBSTRUCTURE EXCAVATION COMMON	C.Y.	105.00
SUBSTRUCTURE EXCAVATION ROCK	C.Y.	10.00
CLASS A CONCRETE	C.Y.	125.80
REINFORCING STEEL	LB.	750.00
EPOXY COATED REINFORCING STEEL	LB.	26,970.00
WATER REPELLENT (VISUALLY INSPECTED)	S.Y.	81.00
DRILLED SHAFTS 72" DIAMETER	L.F.	60.00
ELASTOMERIC COATING	S.F.	342.00

DESIGN		PHASE 4	OKLAHOMA COUNTY
DRAWN		BRIDGE "A"	RAMP "A" AT I-35 & I-240 INTERCHANGE
CHECKED		PIER DETAILS PIER NO. 7 (SHEET 1 OF 3)	
APPROVED			
SQUAD	POE		
		STATE JOB NO. 09032(08)	SHEET NO. B015

3/1/2024 3:20:06 PM H:\PROJECTS\2789_CrossRoads_Phase 4\Bridges\Drawings\Ph4 Bridges\Bridges A\0903208 P4 Bridge A Piers.dgn

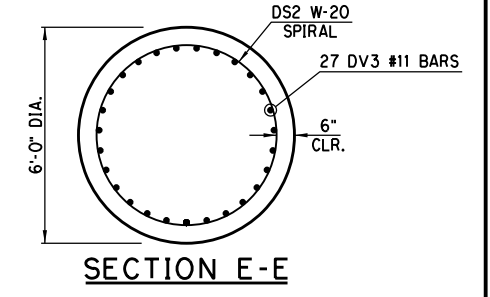
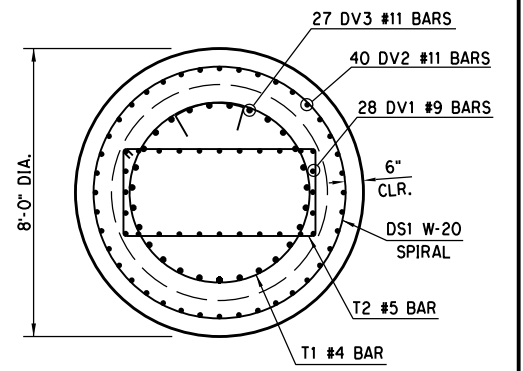
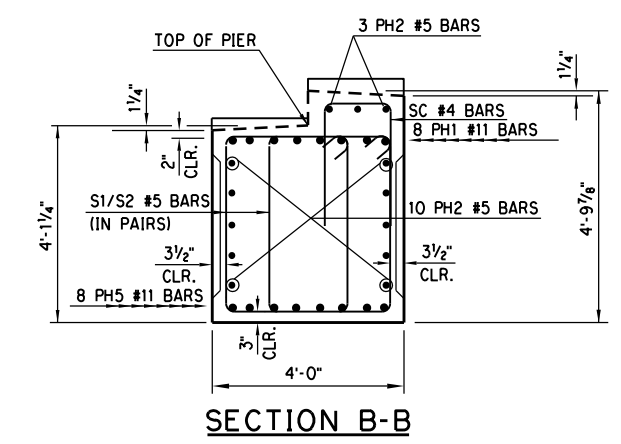
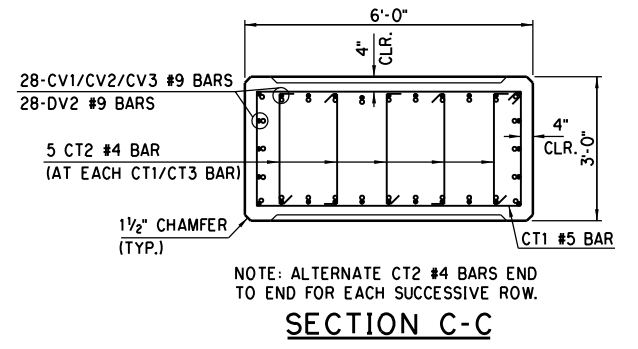
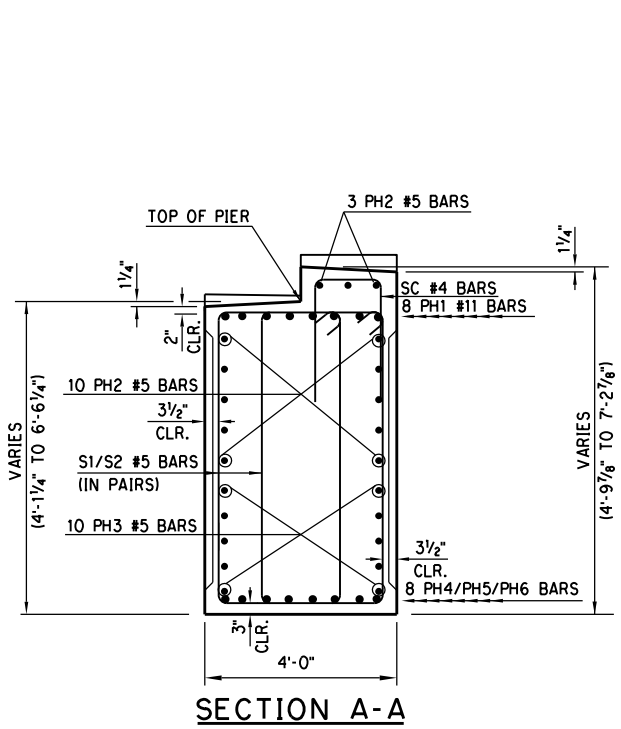
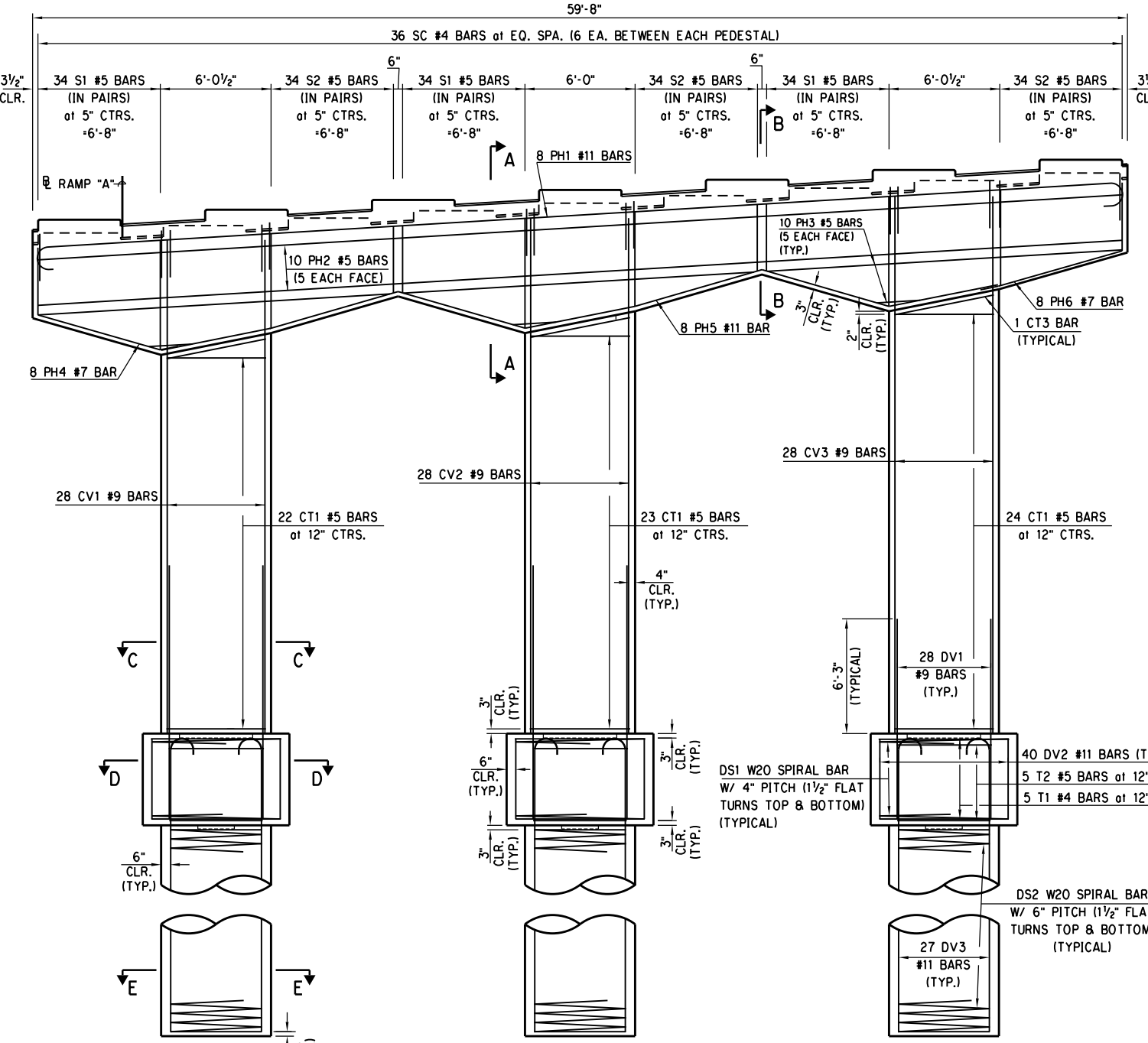
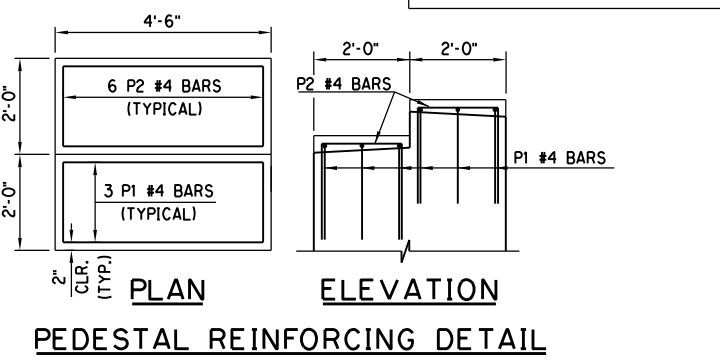
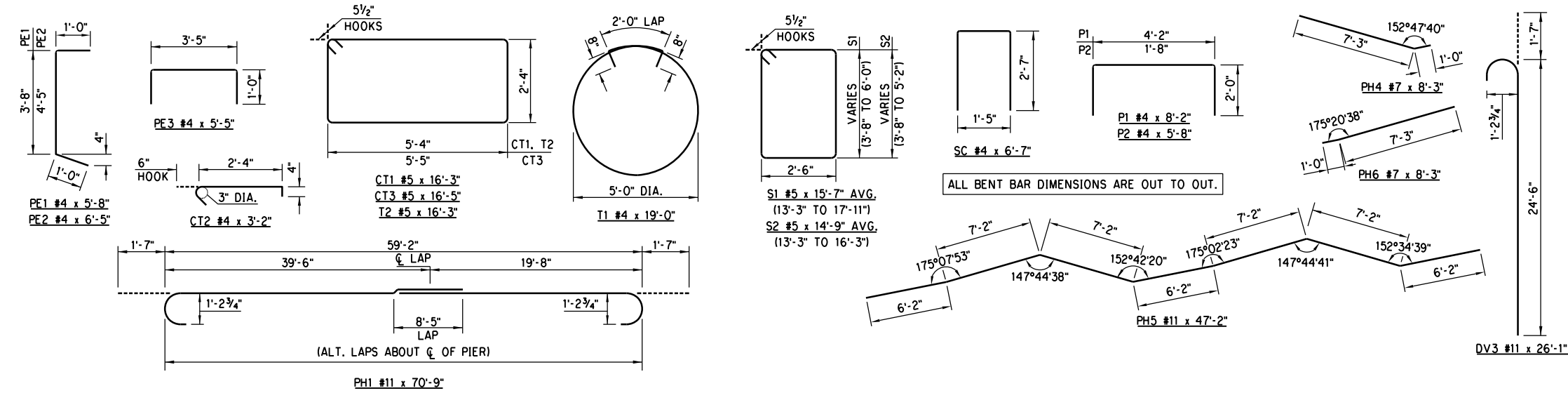

REINFORCING ELEVATION

DESIGN		PHASE 4	OKLAHOMA COUNTY
DRAWN		BRIDGE "A"	RAMP "A" AT I-35 & I-240 INTERCHANGE
CHECKED		PIER DETAILS PIER NO. 7 (SHEET 2 OF 3)	
APPROVED			
SQUAD	POE	STATE JOB NO. 09032(08)	SHEET NO. B016

3/1/2024 3:20:07 PM H:\PROJECTS\2789_CrossRoads\Phase 4\Bridges\Drawings\Ph4 Bridges\Bridges A\0903208 P4 Bridge A Piers.dgn

BAR LIST - PIER NO. 7 (EPOXY COATED)						
MARK	NO.	SIZE	FORM	SPACING	LENGTH	LENGTH VARIATION
CT1	69	#5	BENT	12" C/C	16'-3"	--
CT2	360	#4	BENT	AS SHOWN	3'-2"	--
CT3	3	#5	BENT	AS SHOWN	16'-5"	--
CV1	28	#9	STR.	AS SHOWN	26'-11"	--
CV2	28	#9	STR.	AS SHOWN	28'-1"	--
CV3	28	#9	STR.	AS SHOWN	29'-4"	--
▲ ①	DS1	3	W-20	BENT	AS SHOWN	362'-11"
	DV1	84	#9	STR.	AS SHOWN	11'-0"
	DV2	120	#11	STR.	AS SHOWN	4'-6"
	P1	48	#4	BENT	EQUAL	8'-2"
	P2	96	#4	BENT	EQUAL	5'-8"
	PE1	4	#4	BENT	AS SHOWN	5'-8"
	PE2	4	#4	BENT	AS SHOWN	6'-5"
	PE3	10	#4	BENT	AS SHOWN	5'-5"
②	PH1	8	#11	BENT	AS SHOWN	70'-9"
	PH2	13	#5	STR.	EQUAL	59'-2"
	PH3	30	#5	STR.	EQUAL	10'-8" AVG.
	PH4	8	#7	BENT	AS SHOWN	8'-3"
	PH5	8	#11	BENT	AS SHOWN	47'-2"
	PH6	8	#7	BENT	AS SHOWN	8'-3"
	S1	102	#5	BENT	5" C/C	15'-7" AVG.
	S2	102	#5	BENT	5" C/C	14'-9" AVG.
	SC	36	#4	BENT	EQUAL	6'-7"
②	T1	15	#4	BENT	12" C/C	19'-0"
	T2	15	#5	BENT	12" C/C	16'-3"
BAR LIST - 72" DRILLED SHAFT						
▲ ①	DS2	3	W-20	BENT	AS SHOWN	660'-1"
▲	DV3	81	#11	BENT	AS SHOWN	26'-1"

① LENGTH SHOWN DOES NOT INCLUDE ANY LAPS FOR SPLICES. CONTRACTOR MAY ADD SPLICES AS NECESSARY, BUT PAYMENT WILL NOT BE MADE FOR EXTRA LENGTH REQUIRED. ADD 3'-8" FOR EACH SPLICE.

② LENGTH SHOWN INCLUDES LAP:
PH1 - 1 at 8'-5"
T1 - 1 at 2'-0"

▲ NON-EPOXY COATED

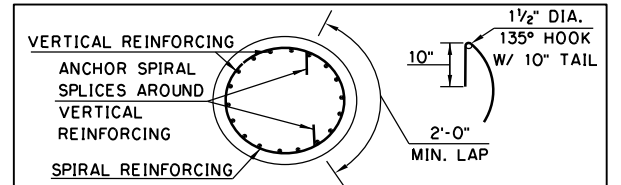

SPIRAL REINFORCING SPLICE DETAILS

NOTE: SPIRAL BARS SHALL CONFORM TO AASHTO M-32. SPIRAL BAR LENGTHS DO NOT INCLUDE LAP. IF LAP IS REQUIRED, THE LENGTH OF THE LAP SHALL BE AS SHOWN.

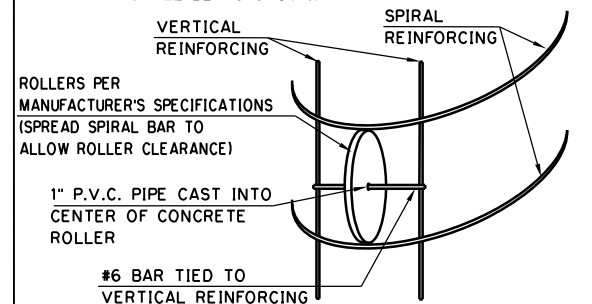

ROLLER INSTALLATION DETAIL

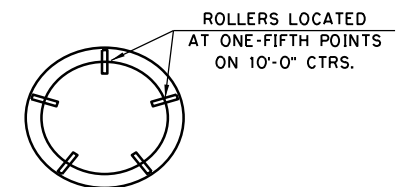

ROLLER PLACEMENT

ROLLER DETAILS

NOTE: REINFORCING CAGE CENTERING DEVICES SHALL CONSIST OF ROLLERS PLACED AT SPACING AS SHOWN AND HAVE THE CHARACTERISTICS AS INDICATED IN THE MANUFACTURER'S SPECIFICATIONS. SLAB BOLSTERS AND HIGH CHAIRS WILL BE ALLOWED BY THE DEPARTMENT.

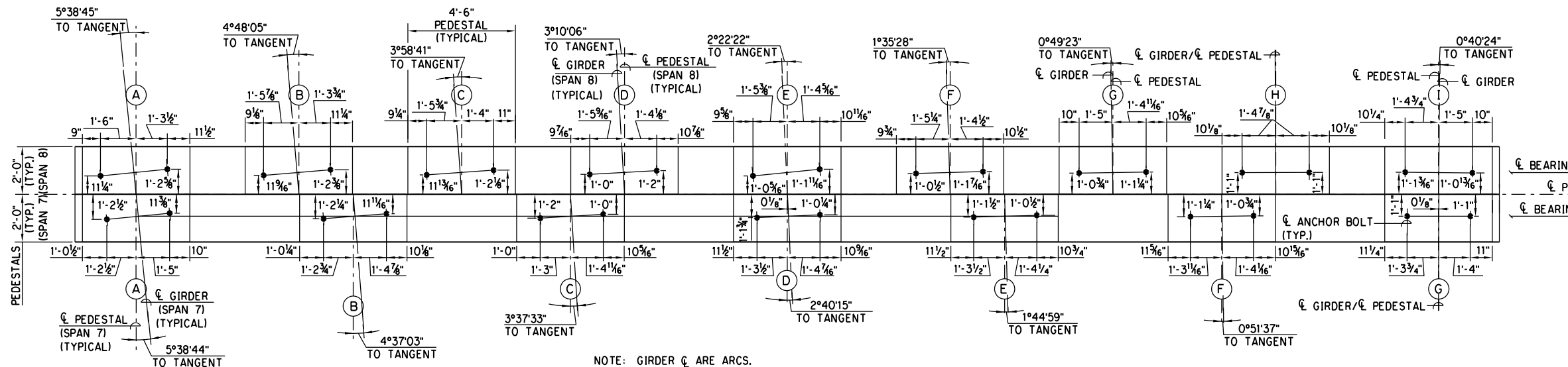

NOTE: GIRDER C ARE ARCS.
EACH PEDESTAL C IS CONGRUENT WITH ITS GIRDER C AT THE PIER C.
EXCEPT SPAN 7 GIRDERS "D" AND "G" C ARE OFFSET FROM PEDESTAL C AS NOTED.

**ANCHOR BOLT LAYOUT
PIER NO. 7**

NOTE: DIMENSIONS SHOWN ARE PERPENDICULAR TO PEDESTALS.
FOR FURTHER INFORMATION SEE "BEARING ASSEMBLY DETAILS" SHEET.

DESIGN		PHASE 4	OKLAHOMA COUNTY
DRAWN		BRIDGE "A"	RAMP "A" AT I-35 & I-240 INTERCHANGE
CHECKED		PIER DETAILS PIER NO. 7 (SHEET 3 OF 3)	
APPROVED			
SQUAD	POE	STATE JOB NO. 09032(08)	SHEET NO. B017

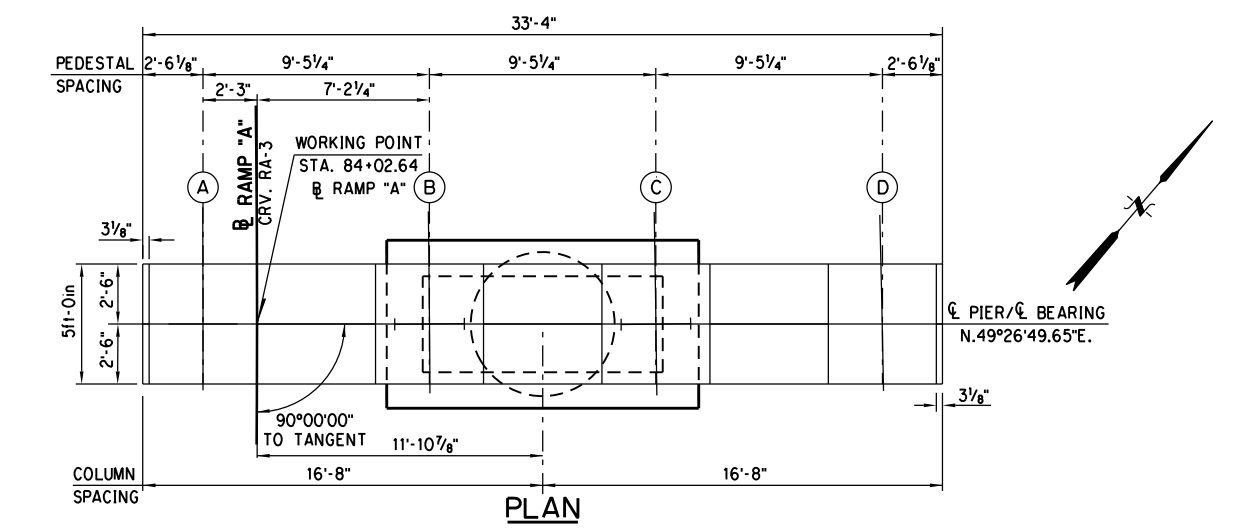

PLAN
(SEE SHEET 3 OF 3
FOR ANCHOR BOLT LAYOUTS)

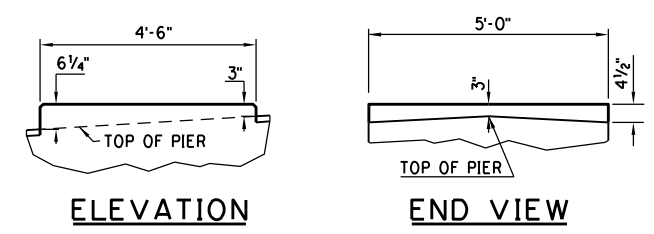

ELEVATION **END VIEW**
PEDESTAL DETAIL
(TYPICAL)

PEDESTAL ELEVATION SCHEDULE - PIER NO. 9				
PEDESTAL	A	B	C	D
SPAN 9-10 ELEV.	1314.12	1314.68	1315.25	1315.82

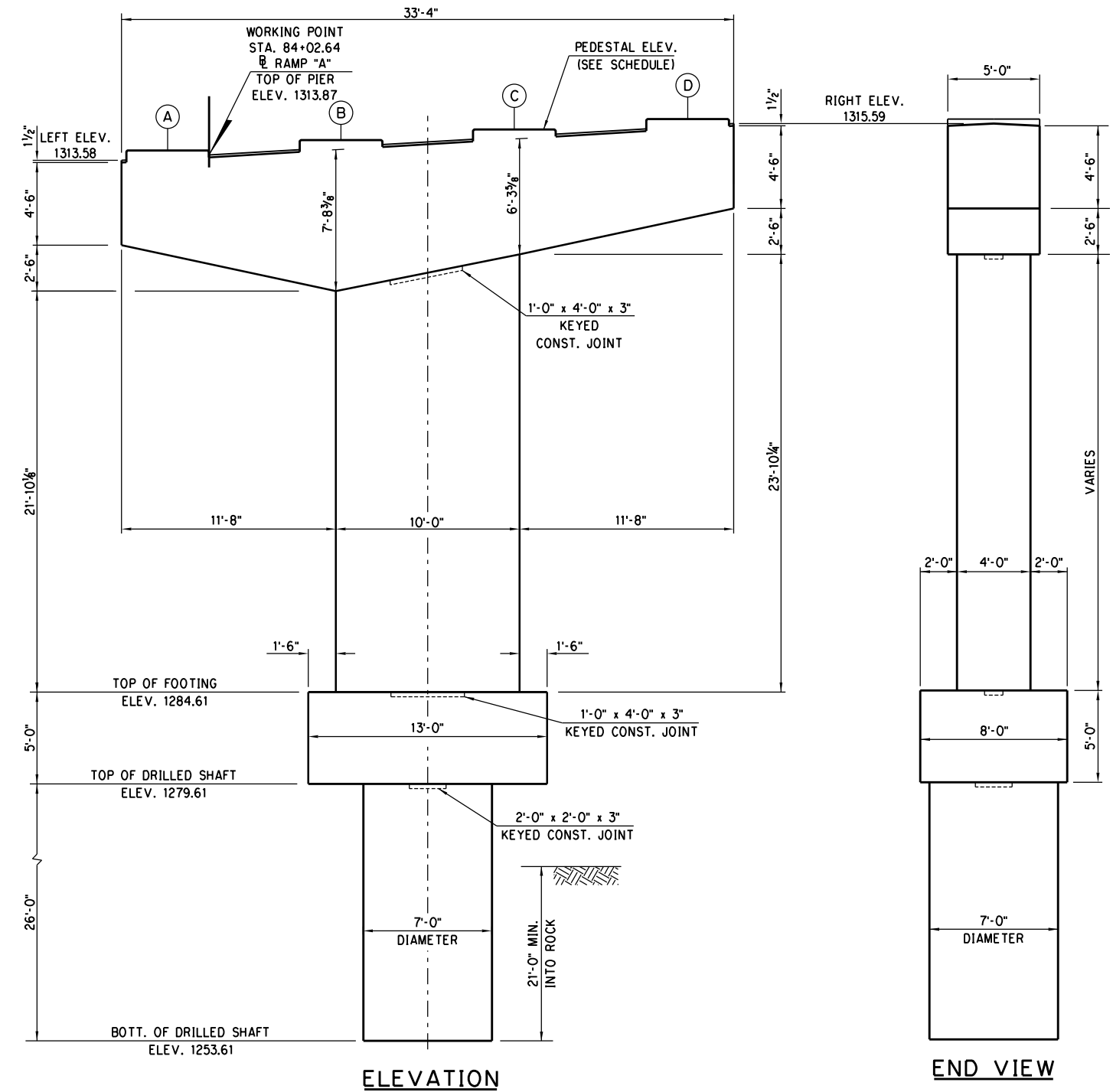

ELEVATION

END VIEW

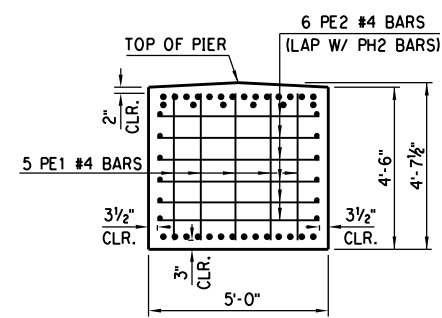

CAP END REINFORCING DETAIL
(PEDESTALS AND S BARS OMITTED FOR CLARITY)

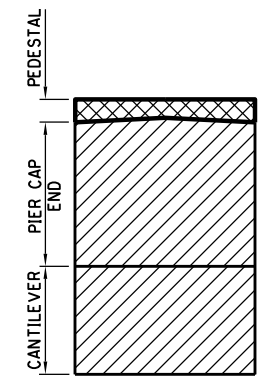

NOTE:
MASK SIDES AND ENDS OF PIER TO PROVIDE A CLEAN STRAIGHT FINISH AT THE BOTTOM EDGE OF ELASTOMERIC COATING APPLICATION.
MASK OUT TOPS OF PEDESTALS WHERE BEARING PADS SIT.

- ELASTOMERIC COATING (CROSS-HATCHING AND HEAVY LINE)
- WATER REPELLENT (HATCHING)

CONCRETE TREATMENT DETAILS

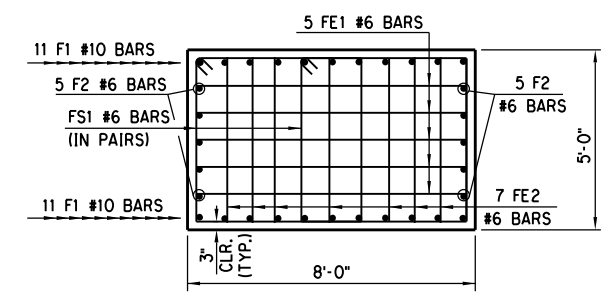

FOOTING END REINFORCING DETAIL

PIER NO. 9 - QUANTITIES		
ITEM	UNIT	TOTAL
SUBSTRUCTURE EXCAVATION COMMON	C.Y.	50.00
CLASS A CONCRETE	C.Y.	92.80
EPOXY COATED REINFORCING STEEL	LB.	22,460.00
WATER REPELLENT (VISUALLY INSPECTED)	S.Y.	55.00
DRILLED SHAFTS 84" DIAMETER	L.F.	26.00
ELASTOMERIC COATING	S.F.	201.00

DESIGN		PHASE 4	OKLAHOMA COUNTY
DRAWN		BRIDGE "A"	RAMP "A" AT I-35 & I-240 INTERCHANGE
CHECKED		<p align="center">PIER DETAILS PIER NO. 9 (SHEET 1 OF 3)</p>	
APPROVED			
SQUAD	POE		
		STATE JOB NO. 09032(08)	SHEET NO. B018

3/1/2024 3:20:11 PM
 H:\PROJECTS\2789_CrossRoads_Phase 4\Bridges\Drawings\Ph4 Bridges\Bridges\A\0903208 P4 Bridge A Piers.dgn

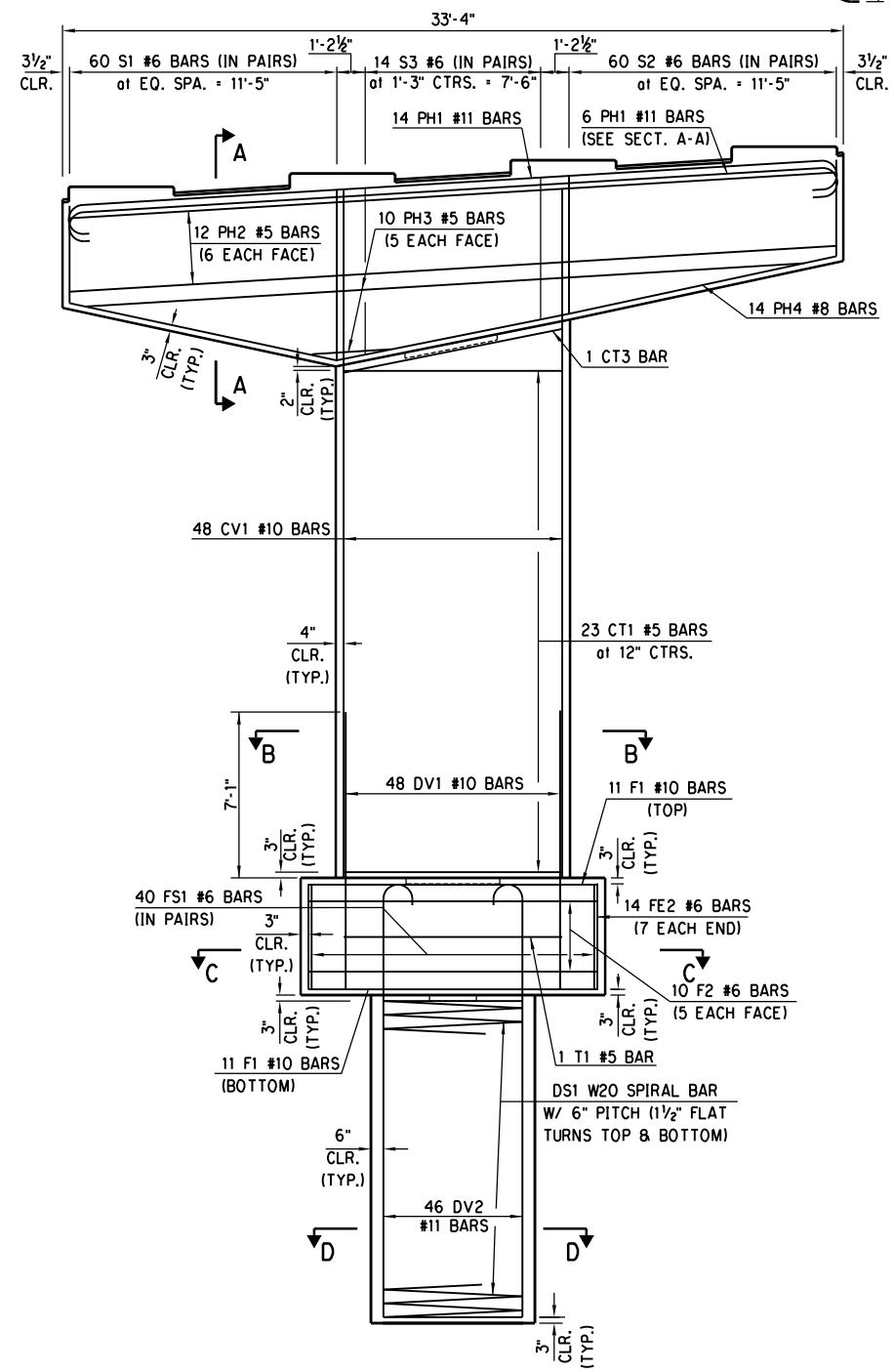
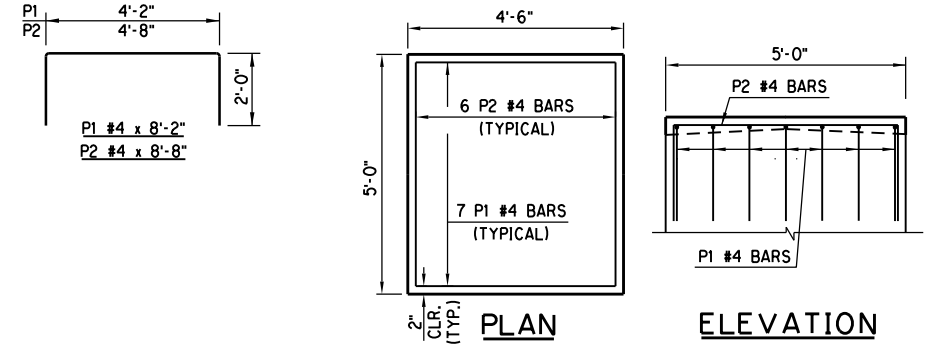
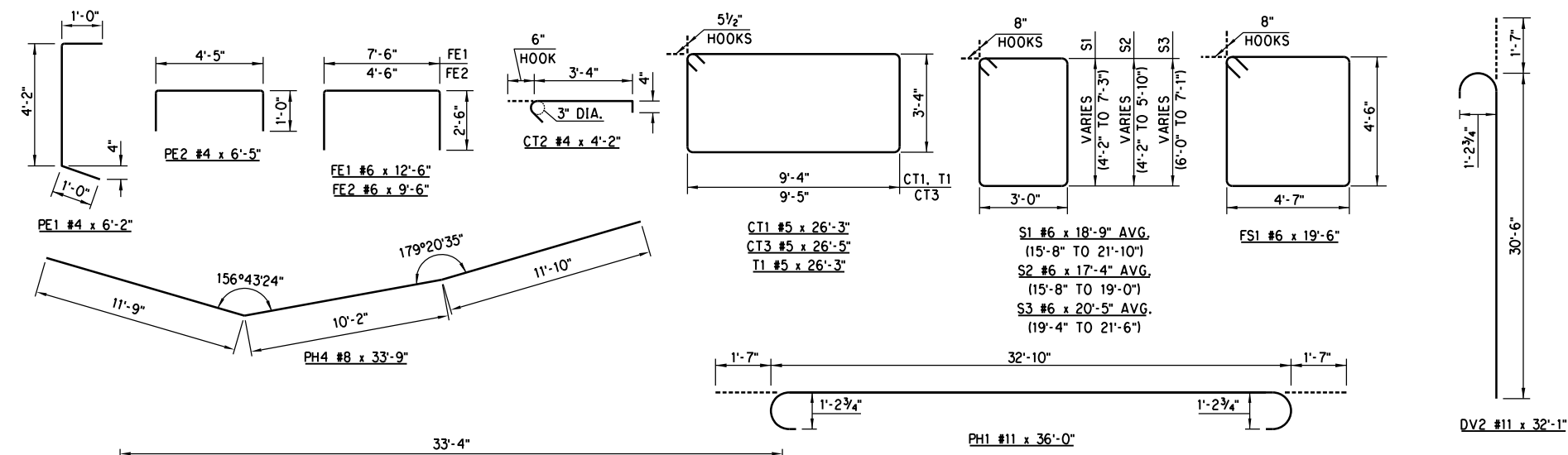

ALL BENT BAR DIMENSIONS ARE OUT TO OUT.

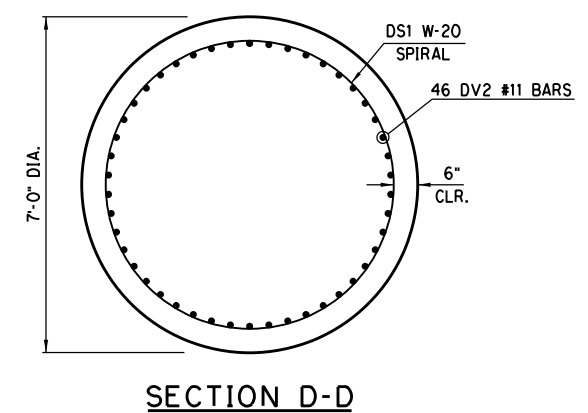
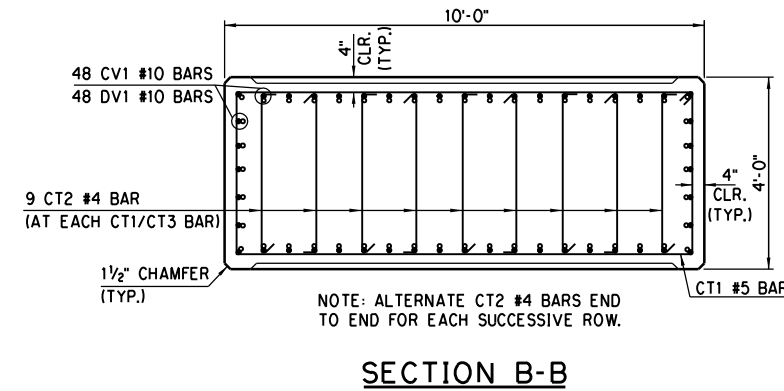
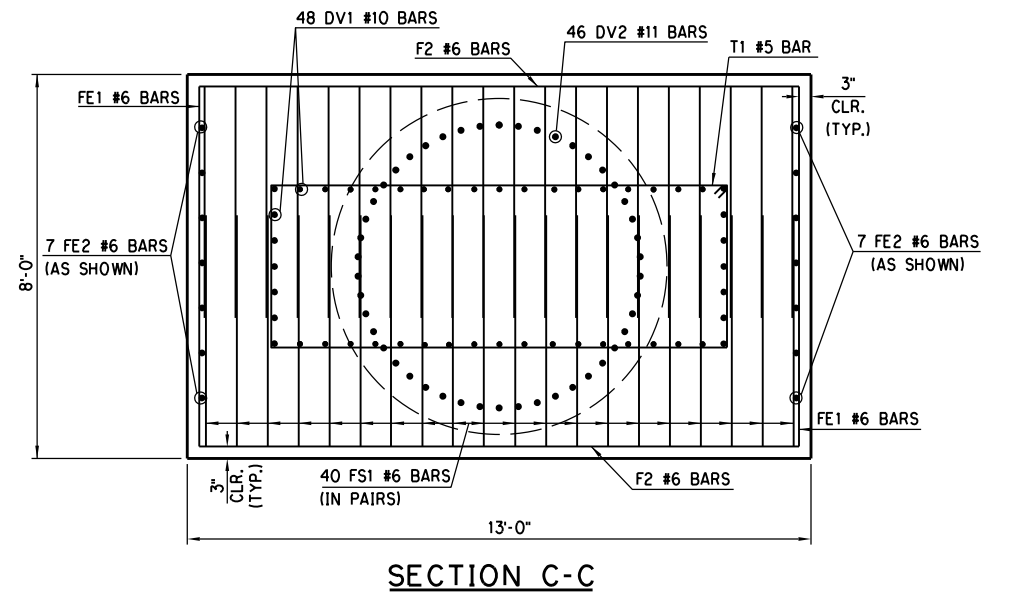
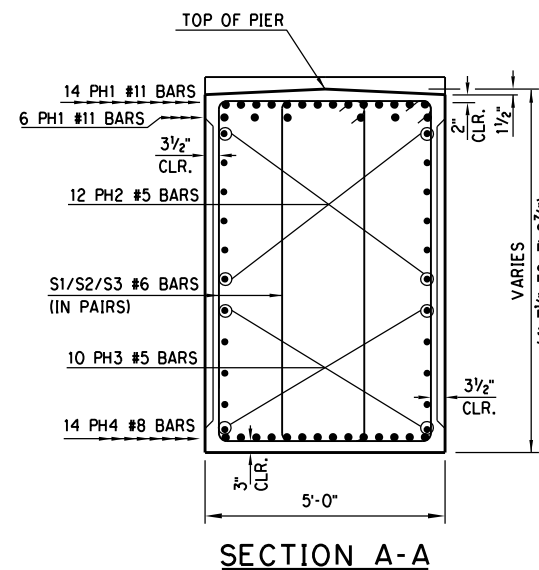

3/1/2024 3:20:43 PM H:\PROJECTS\2789_CrossRoads_Phase 4\Bridges\Drawings\Ph4 Bridges\Bridges\A\0903208 P4 Bridge A Piers.dgn

DESIGN		PHASE 4	OKLAHOMA COUNTY
DRAWN		BRIDGE "A"	RAMP "A" AT I-35 & I-240 INTERCHANGE
CHECKED		PIER DETAILS	
APPROVED			
SQUAD	POE	PIER NO. 9	(SHEET 2 OF 3)
		STATE JOB NO. 09032(08)	SHEET NO. B019

**BAR LIST - PIER NO. 9
(EPOXY COATED)**

MARK	NO.	SIZE	FORM	SPACING	LENGTH	LENGTH VARIATION
CT1	23	#5	BENT	12" C/C	26'-3"	--
CT2	216	#4	BENT	AS SHOWN	4'-2"	--
CT3	1	#5	BENT	AS SHOWN	26'-5"	--
CV1	48	#10	STR.	AS SHOWN	29'-5"	--
DV1	48	#10	STR.	AS SHOWN	11'-10"	--
F1	22	#10	STR.	AS SHOWN	12'-6"	--
F2	10	#6	STR.	AS SHOWN	12'-6"	--
FE1	10	#6	BENT	AS SHOWN	12'-6"	--
FE2	14	#6	BENT	AS SHOWN	9'-6"	--
FS1	40	#6	BENT	EQUAL	19'-6"	--
P1	28	#4	BENT	EQUAL	8'-2"	--
P2	24	#4	BENT	EQUAL	8'-8"	--
PE1	10	#4	BENT	AS SHOWN	6'-2"	--
PE2	12	#4	BENT	AS SHOWN	6'-5"	--
PH1	20	#11	BENT	AS SHOWN	36'-0"	--
PH2	12	#5	STR.	EQUAL	32'-10"	--
PH3	10	#5	STR.	EQUAL	15'-3 1/2"	3'-5" TO 27'-2"
PH4	14	#8	BENT	AS SHOWN	33'-9"	--
S1	60	#6	BENT	5" C/C	18'-9" AVG.	15'-8" TO 21'-10"
S2	60	#6	BENT	5" C/C	17'-4" AVG.	15'-8" TO 19'-0"
S3	14	#6	BENT	1'-3" C/C	20'-5" AVG.	19'-4" TO 21'-6"
T1	1	#4	BENT	12" C/C	26'-3"	--

BAR LIST - 84" DRILLED SHAFT

DS1	1	W-20	BENT	AS SHOWN	1021'-11"	--
DV2	46	#11	BENT	AS SHOWN	32'-1"	--

① LENGTH SHOWN INCLUDES 3'-8" FOR ONE LAP SPLICE. CONTRACTOR MAY ADD SPLICES AS NECESSARY, BUT PAYMENT WILL NOT BE MADE FOR EXTRA LENGTH REQUIRED. ADD 3'-8" FOR EACH SPLICE.

▲ NON-EPOXY COATED

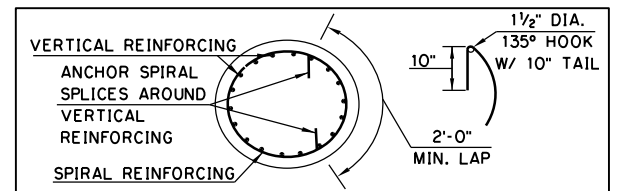

SPIRAL REINFORCING SPLICE DETAILS

NOTE: SPIRAL BARS SHALL CONFORM TO AASHTO M-32. SPIRAL BAR LENGTHS DO NOT INCLUDE LAP. IF LAP IS REQUIRED, THE LENGTH OF THE LAP SHALL BE AS SHOWN.

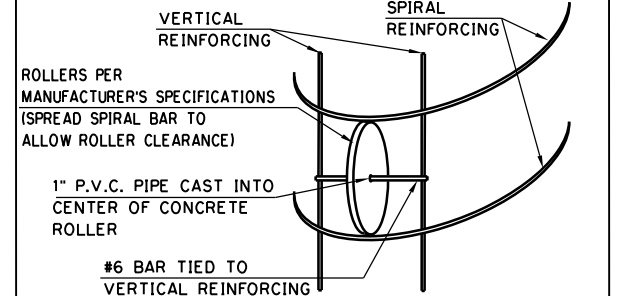

ROLLER INSTALLATION DETAIL

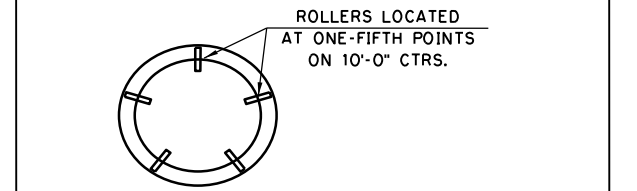

ROLLER PLACEMENT

ROLLER DETAILS

NOTE: REINFORCING CAGE CENTERING DEVICES SHALL CONSIST OF ROLLERS PLACED AT SPACING AS SHOWN AND HAVE THE CHARACTERISTICS AS INDICATED IN THE MANUFACTURER'S SPECIFICATIONS. SLAB BOLSTERS AND HIGH CHAIRS WILL BE ALLOWED BY THE DEPARTMENT.

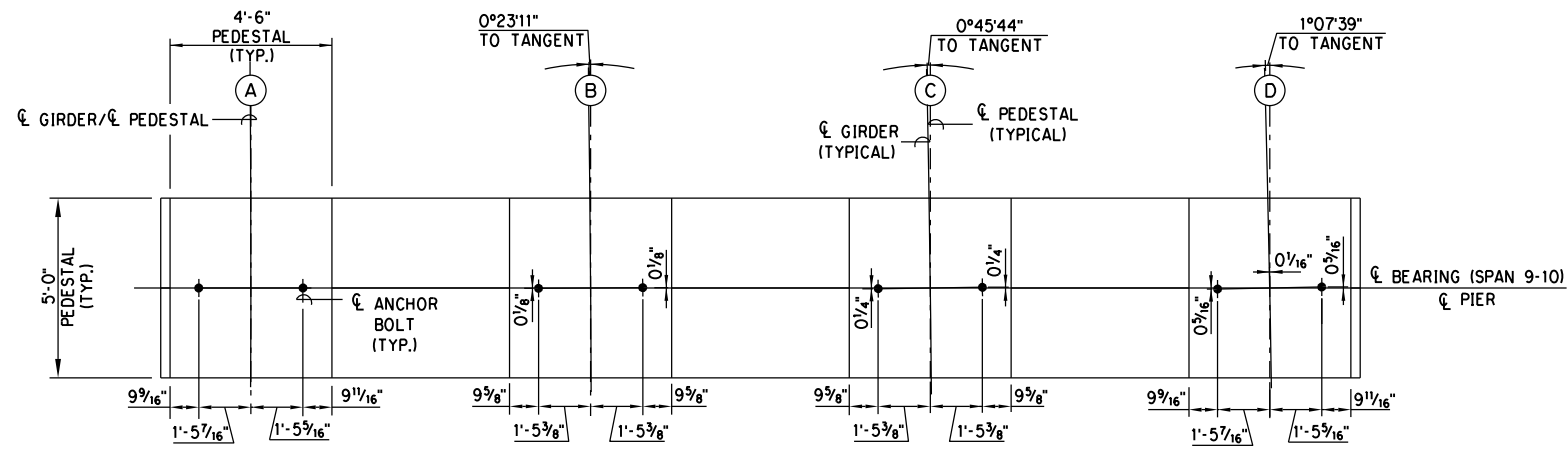

NOTE: GIRDER C ARE ARCS. EACH PEDESTAL C IS CONGRUENT WITH ITS GIRDER C AT THE PIER C. EXCEPT GIRDER D C IS OFFSET FROM PEDESTAL C AS NOTED.

**ANCHOR BOLT LAYOUT
PIER NO. 9**

NOTE: DIMENSIONS SHOWN ARE PERPENDICULAR TO PEDESTALS. FOR FURTHER INFORMATION SEE "BEARING ASSEMBLY DETAILS". SHEET.

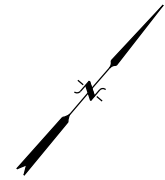

DESIGN		PHASE 4	OKLAHOMA COUNTY
DRAWN		BRIDGE "A"	RAMP "A" AT I-35 & I-240 INTERCHANGE
CHECKED		PIER DETAILS PIER NO. 9 (SHEET 3 OF 3)	
APPROVED			
SQUAD	POE	STATE JOB NO. 09032(08)	SHEET NO. B020

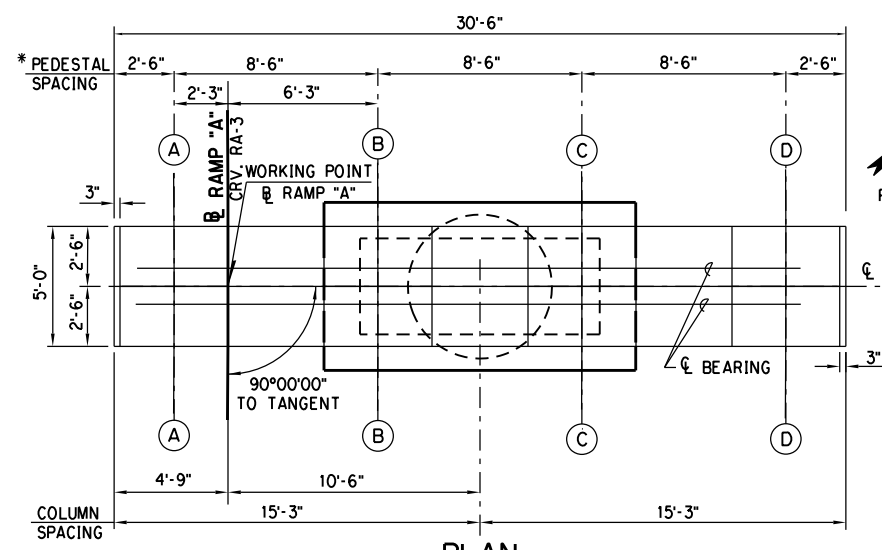

PIER NO. 10
PIER NO. 12
CL PIER N.39°40'55.65"E. (PIER 10)
N.20°09'9.38"E. (PIER 12)

PEDESTAL	A	B	C	D
SPAN 10 ELEVATION	1311.33	1311.84	1312.35	1312.86
SPAN 11 ELEVATION	1311.30	1311.81	1312.32	1312.83

PEDESTAL	A	B	C	D
SPAN 12 ELEVATION	1302.76	1303.27	1303.78	1304.29
SPAN 13 ELEVATION	1303.63	1304.14	1304.65	1305.16

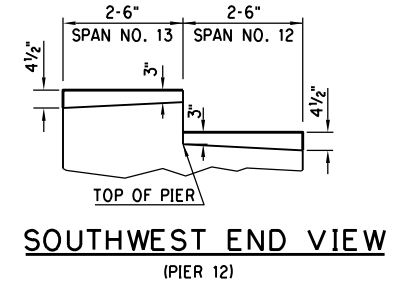
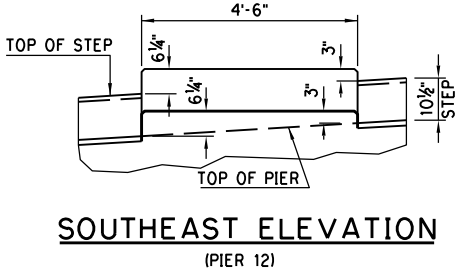
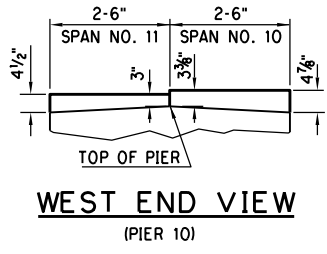
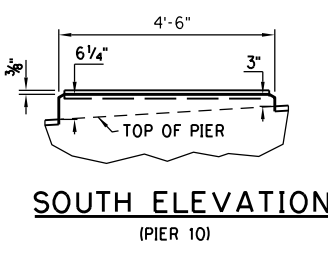

PEDESTAL DETAIL
(TYPICAL)

*SPAN NO. 10 GIRDERS ARE AT 8'-5 9/16" CTRS. AT CL PIER. (THEY ARE AT 8'-6" CTRS. AT BEARING LINE)

(SEE SHEET 3 OF 3 FOR ANCHOR BOLT LAYOUTS)

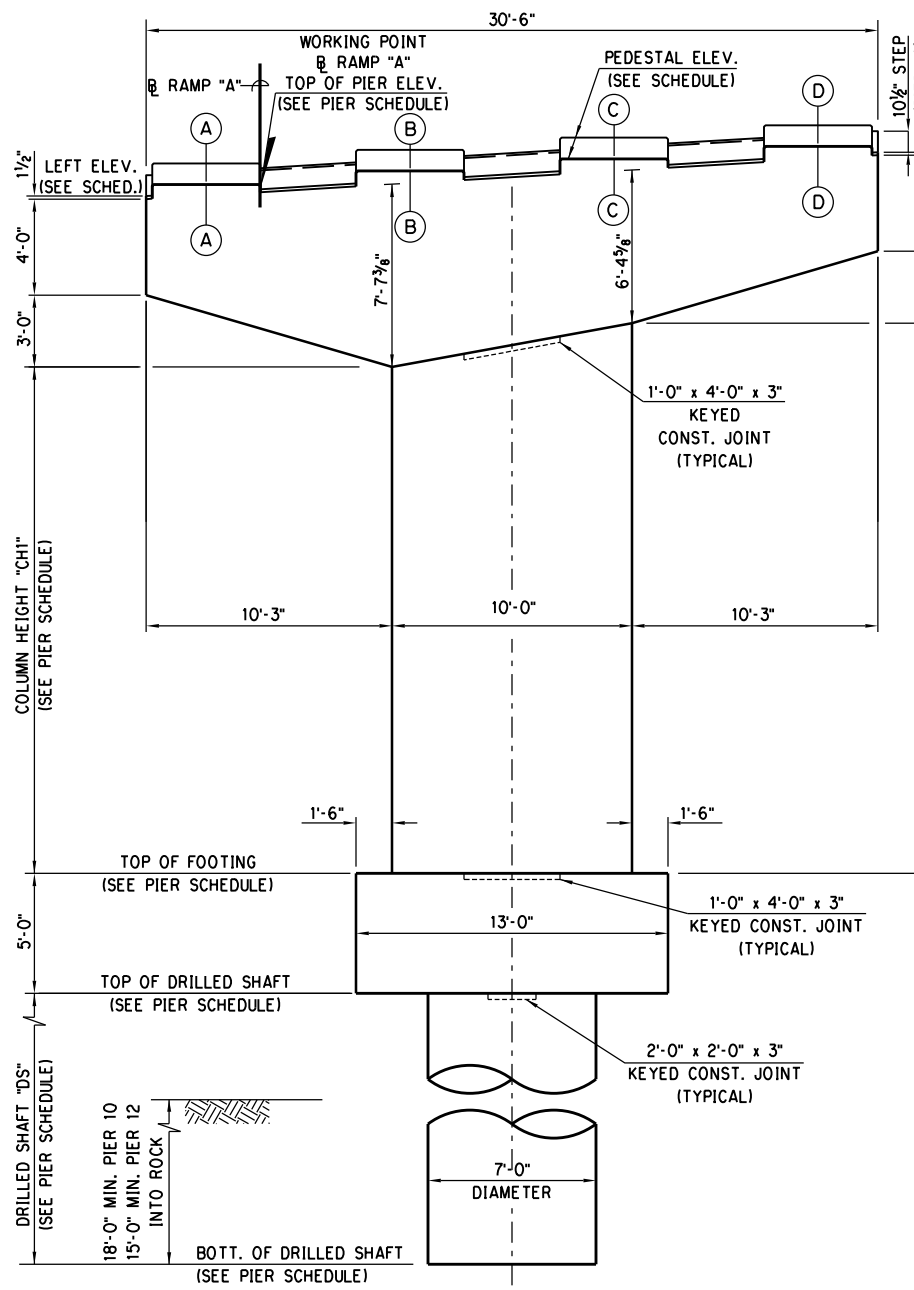

ELEVATION
(PIER 12 SHOWN, PIER 10 SIMILAR, EXPECT PEDESTALS)

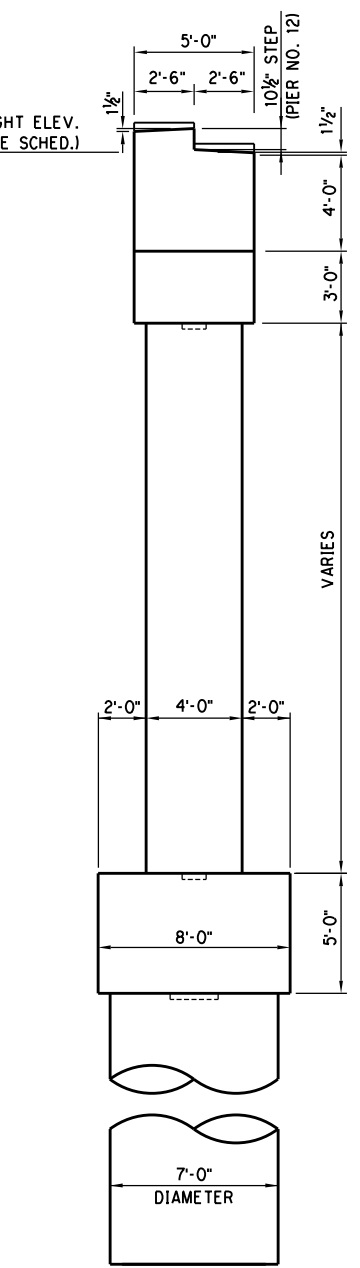

SOUTHWEST END VIEW
(PIER 12 SHOWN)

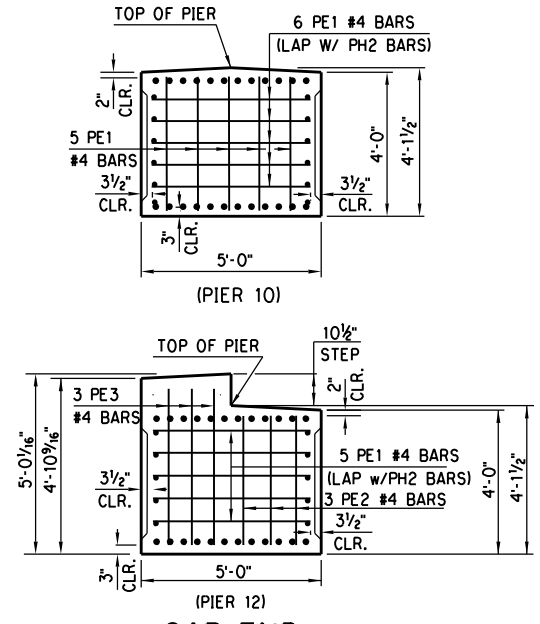

CAP END REINFORCING DETAILS
(PEDESTALS AND S BARS OMITTED FOR CLARITY)

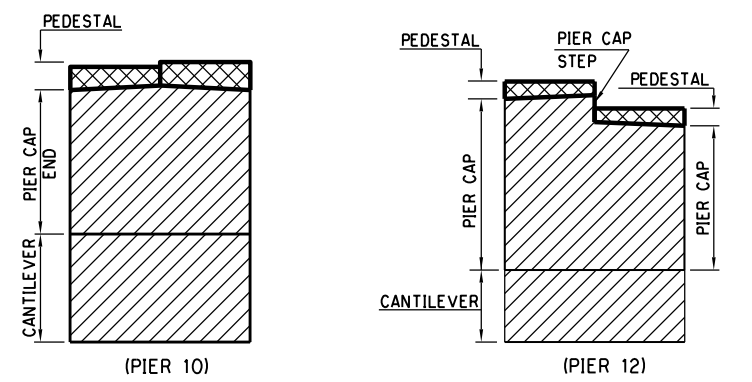

NOTE:
MASK SIDES AND ENDS OF PIER TO PROVIDE A CLEAN STRAIGHT FINISH AT THE BOTTOM EDGE OF ELASTOMERIC COATING APPLICATION. MASK OUT TOPS OF PEDESTALS WHERE BEARING PADS SIT.

CONCRETE TREATMENT DETAILS

PIER	WORKING POINT STA.	TOP OF PIER ELEVATION	LEFT ELEVATION	RIGHT ELEVATION	DIM. "CH1"	DIM. "CH2"	DIM. "DS"	TOP OF FTG. ELEVATION	TOP OF D.S. ELEVATION	BOTT. OF D.S. ELEVATION
PIER NO. 10	85+42.14	1311.05	1310.77	1312.60	20'-6 1/2"	22'-4 1/2"	26'-0"	1283.10	1278.10	1252.10
PIER NO. 12	88+21.14	1302.51	1302.23	1304.06	20'-1 1/4"	21'-11 1/4"	19'-0"	1275.00	1270.00	1251.00

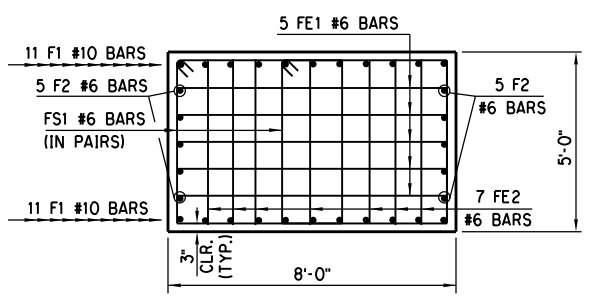

FOOTING END REINFORCING DETAIL

ITEM	UNIT	PIER NO. 10	PIER NO. 12
SUBSTRUCTURE EXCAVATION COMMON	C.Y.	50.00	160.00
CLASS A CONCRETE	C.Y.	87.30	89.10
EPOXY COATED REINFORCING STEEL	LB.	18,690.00	18,790.00
WATER REPELLENT (VISUALLY INSPECTED)	S.Y.	50.00	50.00
DRILLED SHAFTS 84" DIAMETER	L.F.	26.00	19.00
ELASTOMERIC COATING	S.F.	188.00	214.00

PHASE 4 OKLAHOMA COUNTY
BRIDGE "A" RAMP "A" AT I-35 & I-240 INTERCHANGE

PIER DETAILS
PIER NO. 10 AND 12
(SHEET 1 OF 3)

STATE JOB NO. 09032(08) SHEET NO. B021

DESIGN	
DRAWN	
CHECKED	
APPROVED	
SQUAD	POE

3/1/2024 3:20:47 PM H:\PROJECTS\2789_CrossRoads_Phase 4\Bridges\Drawings\Ph4 Bridges\Bridges\A\0903208 P4 Bridge A Piers.dgn

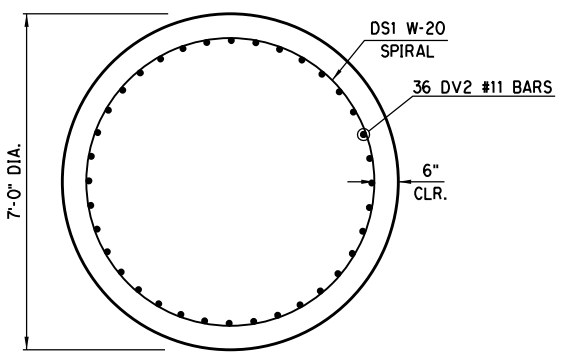
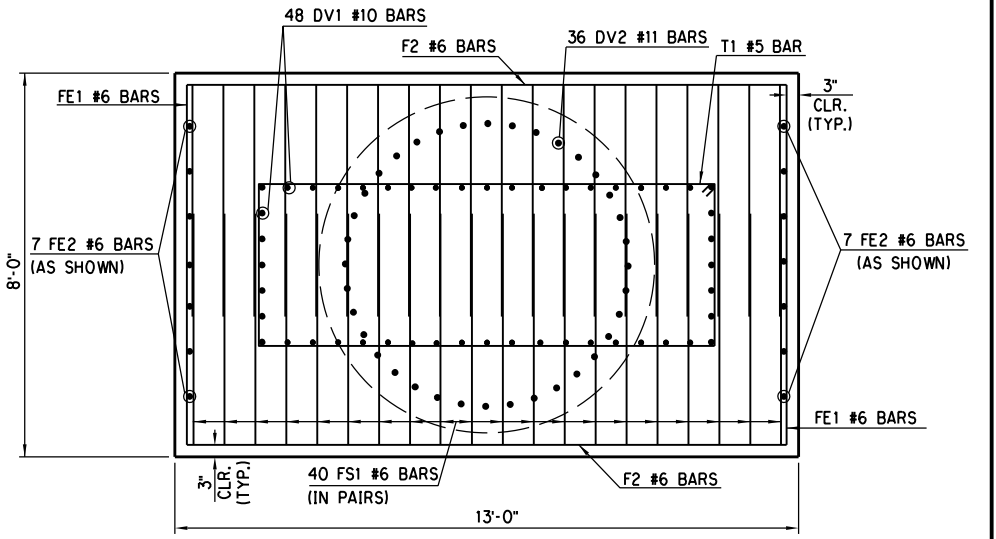
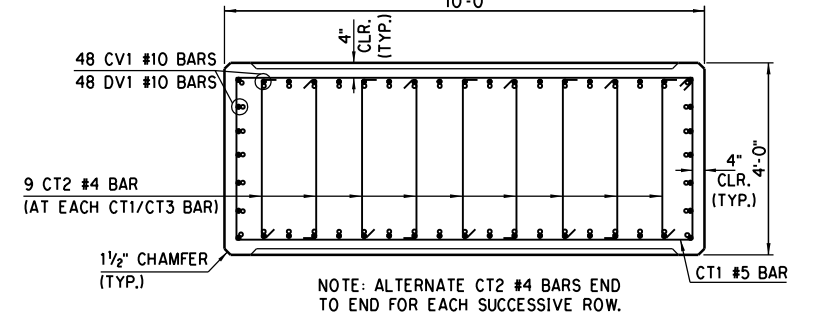
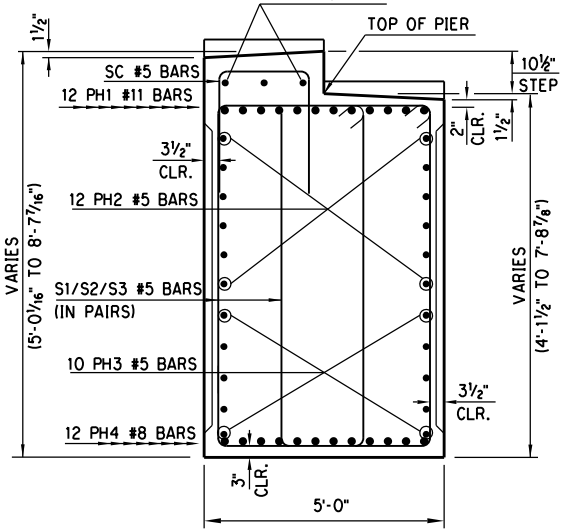
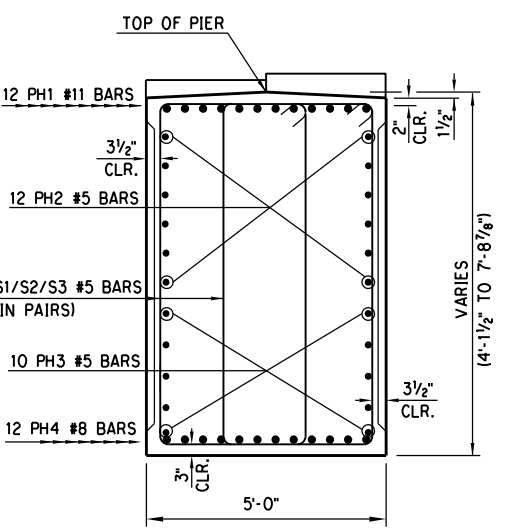
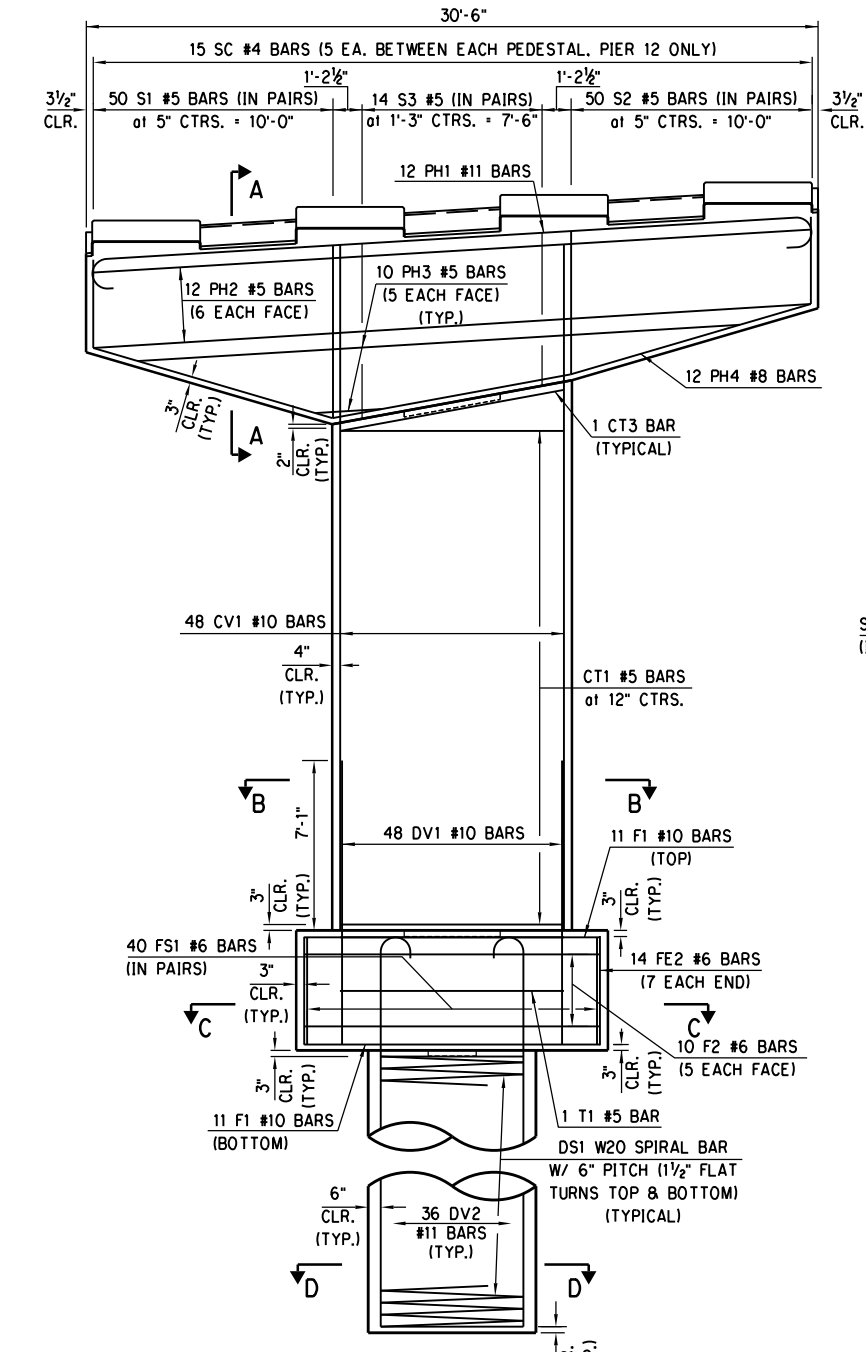
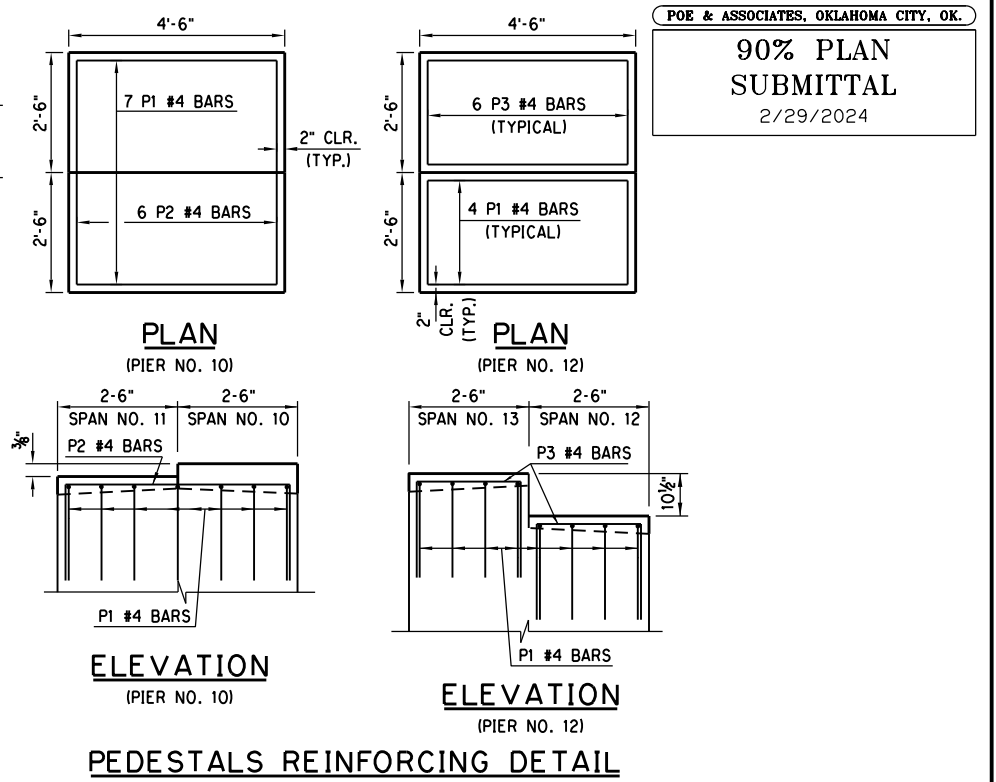
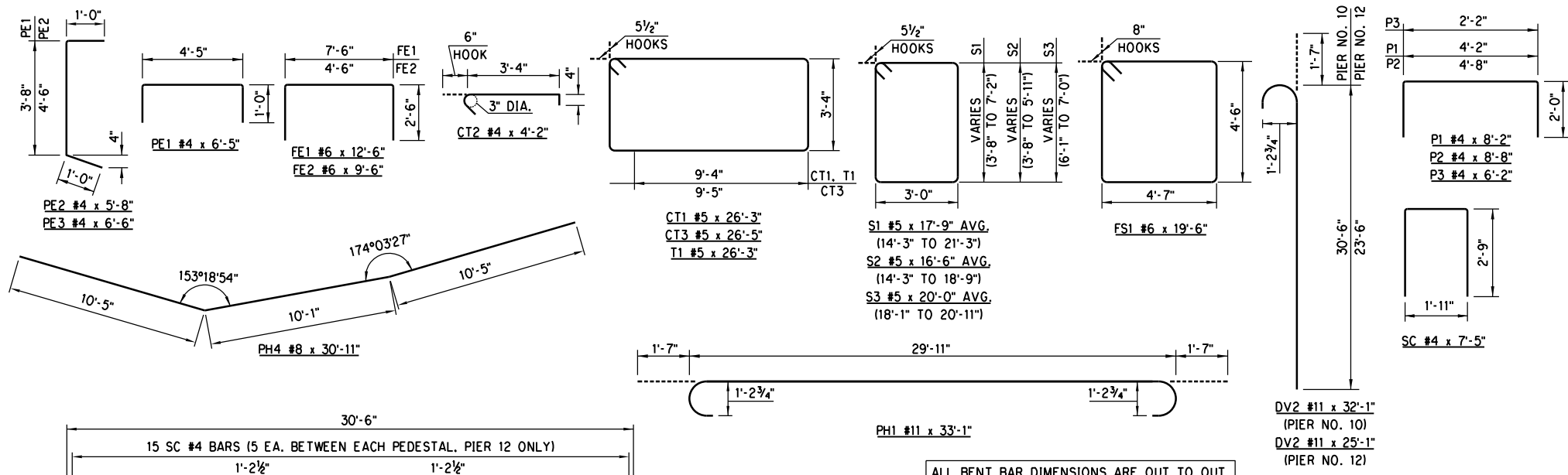

REINFORCING ELEVATION
(PIER 12 SHOWN, PIER 10 SIMILAR, EXCEPT PEDESTALS)

SECTION B-B

NOTE: ALTERNATE CT2 #4 BARS END TO END FOR EACH SUCCESSIVE ROW.

DESIGN		PHASE 4	OKLAHOMA COUNTY
DRAWN		BRIDGE "A"	RAMP "A" AT I-35 & I-240 INTERCHANGE
CHECKED		PIER DETAILS PIER NO. 10 AND 12 (SHEET 2 OF 3)	
APPROVED			
SQUAD	POE		
		STATE JOB NO. 09032(08)	SHEET NO. B022

3/1/2024 3:20:49 PM H:\PROJECTS\2789_CrossRoads_Phase 4\Bridges\Drawings\Ph4 Bridges\Bridg A\0903208 P4 Bridge A Piers.dgn

BAR LIST - PIER NO. 10 (EPOXY COATED)						
MARK	NO.	SIZE	FORM	SPACING	LENGTH	LENGTH VARIATION
CT1	22	#5	BENT	12" C/C	26'-3"	--
CT2	207	#4	BENT	AS SHOWN	4'-2"	--
CT3	1	#5	BENT	AS SHOWN	26'-5"	--
CV1	48	#10	STR.	AS SHOWN	29'-1"	--
DV1	48	#10	STR.	AS SHOWN	11'-10"	--
F1	22	#10	STR.	AS SHOWN	12'-6"	--
F2	10	#6	STR.	AS SHOWN	12'-6"	--
FE1	10	#6	BENT	AS SHOWN	12'-6"	--
FE2	14	#6	BENT	AS SHOWN	9'-6"	--
FS1	40	#6	BENT	EQUAL	19'-6"	--
P1	28	#4	BENT	EQUAL	8'-2"	--
P2	24	#4	BENT	EQUAL	8'-8"	--
PE1	12	#4	BENT	AS SHOWN	6'-5"	--
PE2	10	#4	BENT	AS SHOWN	5'-8"	--
PH1	12	#11	BENT	AS SHOWN	33'-1"	--
PH2	12	#5	STR.	EQUAL	29'-11"	--
PH3	10	#5	STR.	EQUAL	13'-11 1/2" AVG.	2'-9" TO 25'-2"
PH4	12	#8	BENT	AS SHOWN	30'-11"	--
S1	50	#5	BENT	5" C/C	17'-9" AVG.	14'-3" TO 21'-3"
S2	50	#5	BENT	5" C/C	16'-6" AVG.	14'-3" TO 18'-9"
S3	14	#5	BENT	1'-3" C/C	20'-0" AVG.	19'-1" TO 20'-11"
T1	1	#4	BENT	12" C/C	26'-3"	--
BAR LIST - 84" DRILLED SHAFT						
DS1	1	W-20	BENT	AS SHOWN	1021'-11"	--
DV2	36	#11	BENT	AS SHOWN	32'-1"	--

▲ ①

① LENGTH SHOWN INCLUDES 3'-8" FOR ONE LAP SPLICE. CONTRACTOR MAY ADD SPLICES AS NECESSARY, BUT PAYMENT WILL NOT BE MADE FOR EXTRA LENGTH REQUIRED. ADD 3'-8" FOR EACH SPLICE.

▲ NON-EPOXY COATED

BAR LIST - PIER NO. 12 (EPOXY COATED)						
MARK	NO.	SIZE	FORM	SPACING	LENGTH	LENGTH VARIATION
CT1	21	#5	BENT	12" C/C	26'-3"	--
CT2	198	#4	BENT	AS SHOWN	4'-2"	--
CT3	1	#5	BENT	AS SHOWN	26'-5"	--
CV1	48	#10	STR.	AS SHOWN	28'-7"	--
DV1	48	#10	STR.	AS SHOWN	11'-10"	--
F1	22	#10	STR.	AS SHOWN	12'-6"	--
F2	10	#6	STR.	AS SHOWN	12'-6"	--
FE1	10	#6	BENT	AS SHOWN	12'-6"	--
FE2	14	#6	BENT	AS SHOWN	9'-6"	--
FS1	40	#6	BENT	EQUAL	19'-6"	--
P1	32	#4	BENT	EQUAL	8'-2"	--
P3	48	#4	BENT	EQUAL	6'-2"	--
PE1	10	#4	BENT	AS SHOWN	6'-5"	--
PE2	6	#4	BENT	AS SHOWN	5'-8"	--
PE3	6	#4	BENT	AS SHOWN	6'-6"	--
PH1	12	#11	BENT	AS SHOWN	33'-1"	--
PH2	15	#5	STR.	EQUAL	29'-11"	--
PH3	10	#5	STR.	EQUAL	13'-11 1/2" AVG.	2'-9" TO 25'-2"
PH4	12	#8	BENT	AS SHOWN	30'-11"	--
S1	50	#5	BENT	5" C/C	17'-9" AVG.	14'-3" TO 21'-3"
S2	50	#5	BENT	5" C/C	16'-6" AVG.	14'-3" TO 18'-9"
S3	14	#5	BENT	1'-3" C/C	20'-0" AVG.	19'-1" TO 20'-11"
SC	15	#4	BENT	EQUAL	7'-5"	--
T1	1	#4	BENT	12" C/C	26'-3"	--
BAR LIST - 84" DRILLED SHAFT						
DS1	1	W-20	BENT	AS SHOWN	757'-11"	--
DV2	36	#11	BENT	AS SHOWN	25'-1"	--

▲ ①

① LENGTH SHOWN INCLUDES 3'-8" FOR ONE LAP SPLICE. CONTRACTOR MAY ADD SPLICES AS NECESSARY, BUT PAYMENT WILL NOT BE MADE FOR EXTRA LENGTH REQUIRED. ADD 3'-8" FOR EACH SPLICE.

▲ NON-EPOXY COATED

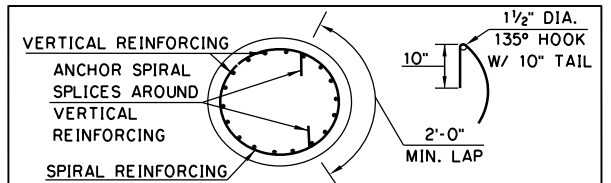

SPIRAL REINFORCING SPLICE DETAILS

NOTE: SPIRAL BARS SHALL CONFORM TO AASHTO M-32. SPIRAL BAR LENGTHS DO NOT INCLUDE LAP. IF LAP IS REQUIRED, THE LENGTH OF THE LAP SHALL BE AS SHOWN.

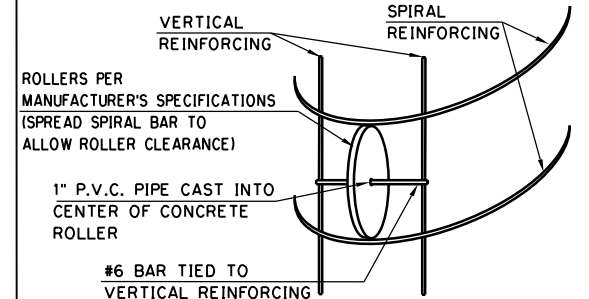

ROLLER INSTALLATION DETAIL

ROLLERS PER MANUFACTURER'S SPECIFICATIONS (SPREAD SPIRAL BAR TO ALLOW ROLLER CLEARANCE)

ROLLERS LOCATED AT ONE-FIFTH POINTS ON 10'-0" CTRS.

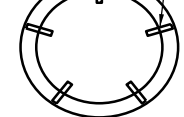

ROLLER PLACEMENT

ROLLER DETAILS

NOTE: REINFORCING CAGE CENTERING DEVICES SHALL CONSIST OF ROLLERS PLACED AT SPACING AS SHOWN AND HAVE THE CHARACTERISTICS AS INDICATED IN THE MANUFACTURER'S SPECIFICATIONS. SLAB BOLSTERS AND HIGH CHAIRS WILL BE ALLOWED BY THE DEPARTMENT.

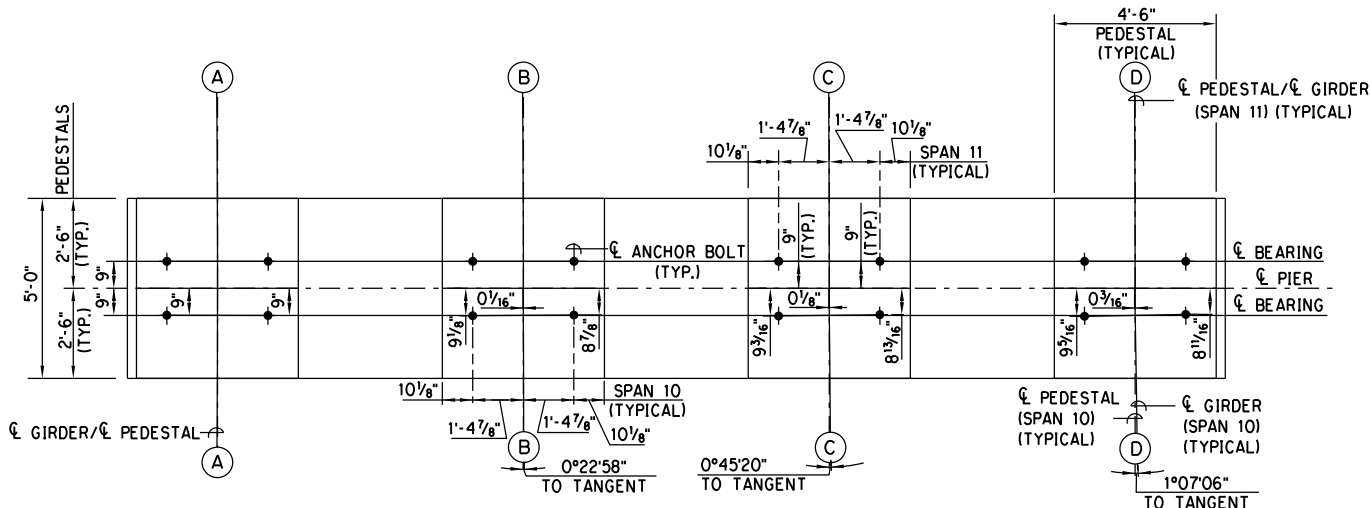

NOTE: GIRDER C ARE ARCS.
FOR SPAN 10 PEDESTAL "A" C IS CONGRUENT WITH ITS GIRDER C AT THE PIER C.
SPAN 10 GIRDERS "B", "C" AND "D" C ARE OFFSET FROM PEDESTAL C AS NOTED.
FOR SPAN 11 EACH PEDESTAL C IS CONGRUENT WITH ITS GIRDER C AT THE PIER C.

**ANCHOR BOLT LAYOUT
PIER NO. 10**

NOTE: DIMENSIONS SHOWN ARE PERPENDICULAR TO PEDESTALS.
FOR FURTHER INFORMATION SEE "BEARING ASSEMBLY DETAILS", SHEET.

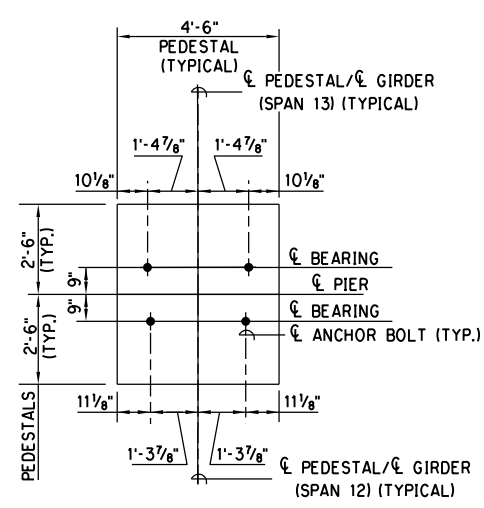

NOTE: GIRDER C ARE ARCS.
EACH PEDESTAL C IS CONGRUENT WITH ITS GIRDER C AT THE PIER C.

**ANCHOR BOLT LAYOUT
PIER NO. 12**

NOTE: DIMENSIONS SHOWN ARE PERPENDICULAR TO PEDESTALS.
FOR FURTHER INFORMATION SEE "BEARING ASSEMBLY DETAILS", SHEET.

DESIGN		PHASE 4	OKLAHOMA COUNTY
DRAWN		BRIDGE "A"	RAMP "A" AT I-35 & I-240 INTERCHANGE
CHECKED		PIER DETAILS PIER NO. 10 AND 12 (SHEET 3 OF 3)	
APPROVED			
SQUAD	POE	STATE JOB NO. 09032(08)	SHEET NO. B023

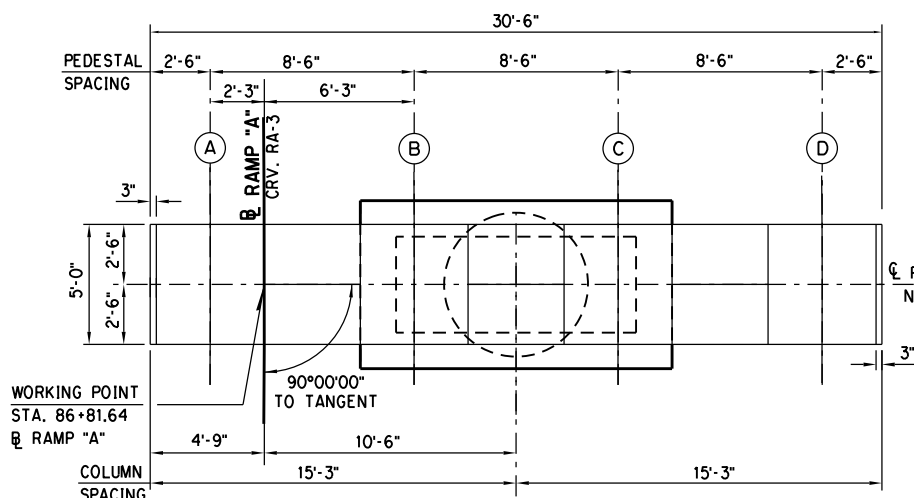

PEDESTAL ELEVATION SCHEDULE - PIER NO. 11

PEDESTAL	A	B	C	D
SPAN 11-12 ELEV.	1306.95	1307.46	1307.97	1308.48

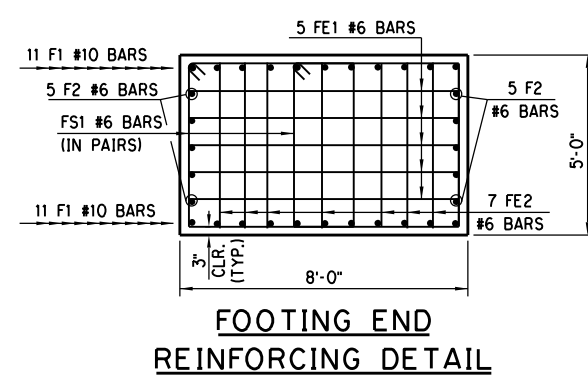
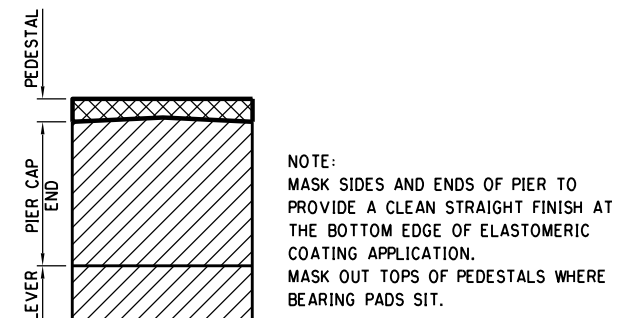
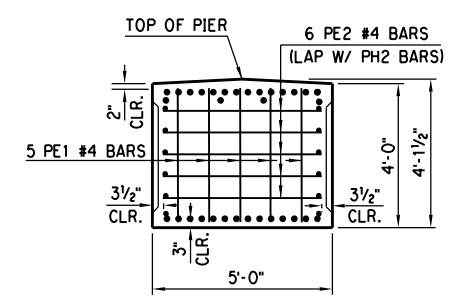
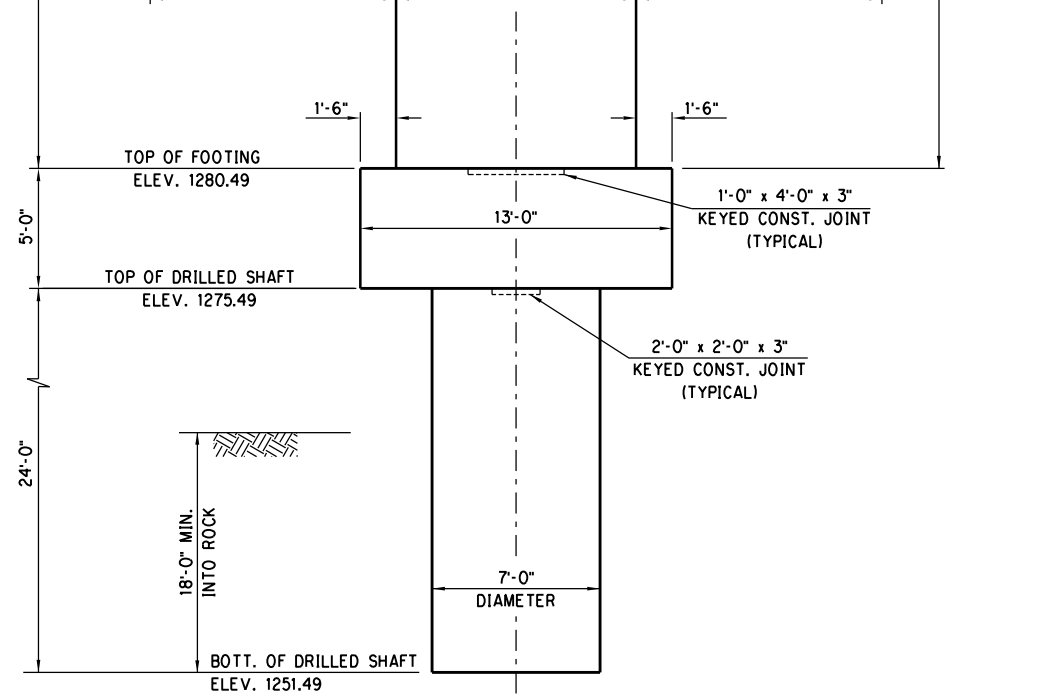
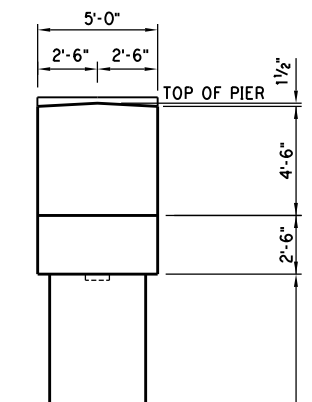
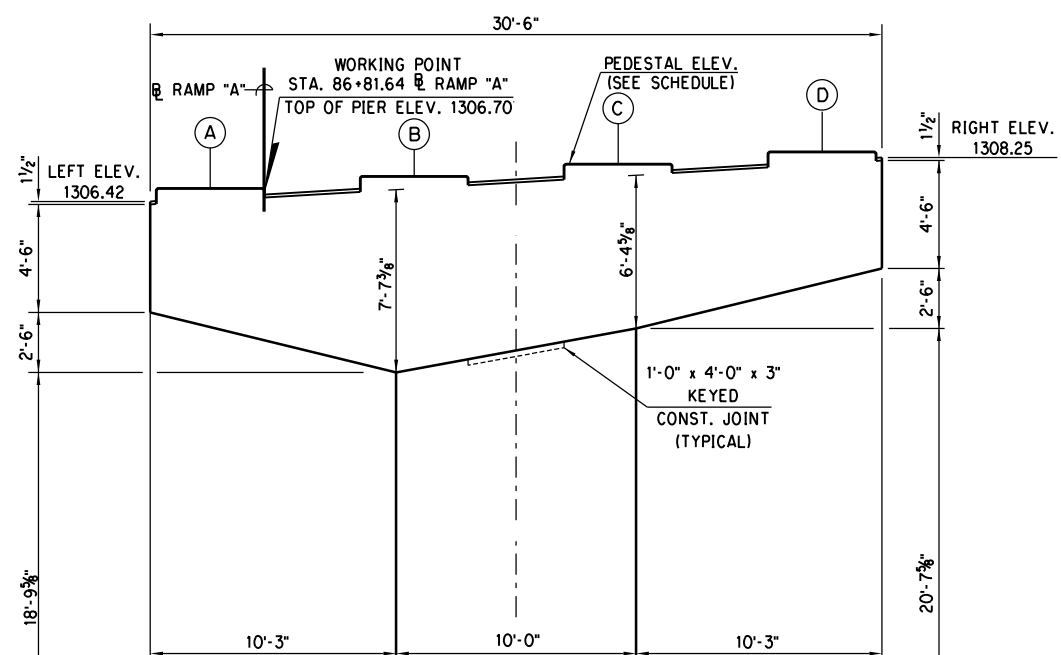
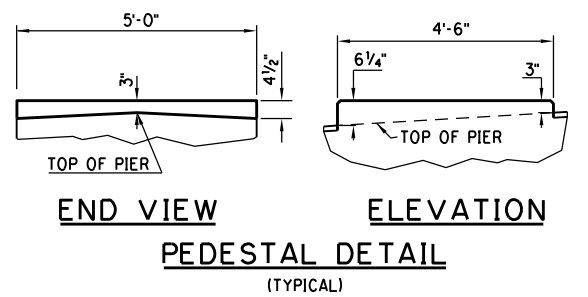

PIER NO. 11 - QUANTITIES

ITEM	UNIT	TOTAL
SUBSTRUCTURE EXCAVATION COMMON	C.Y.	45.00
CLASS A CONCRETE	C.Y.	85.20
EPOXY COATED REINFORCING STEEL	LB.	19,860.00
WATER REPELLENT (VISUALLY INSPECTED)	S.Y.	51.00
DRILLED SHAFTS 84" DIAMETER	L.F.	24.00
ELASTOMERIC COATING	S.F.	187.00

PHASE 4 BRIDGE "A" OKLAHOMA COUNTY

DESIGN: []
 DRAWN: []
 CHECKED: []
 APPROVED: []
 SQUAD: POE

RAMP "A" AT I-35 & I-240 INTERCHANGE

PIER DETAILS
 PIER NO. 11
 (SHEET 1 OF 3)

STATE JOB NO. 09032(08) SHEET NO. B024

3/1/2024 3:20:24 PM
 H:\PROJECTS\2789_CrossRoads_Phase 4 Bridge\Drawings\Phase 4 Bridge\Drawings\Phase 4 Bridge A Piers.dgn

BAR LIST - PIER NO. 11 (EPOXY COATED)						
MARK	NO.	SIZE	FORM	SPACING	LENGTH	LENGTH VARIATION
CT1	20	#5	BENT	12" C/C	26'-3"	--
CT2	189	#4	BENT	AS SHOWN	4'-2"	--
CT3	1	#5	BENT	AS SHOWN	26'-5"	--
CV1	48	#10	STR.	AS SHOWN	26'-3"	--
DV1	48	#10	STR.	AS SHOWN	11'-10"	--
F1	22	#10	STR.	AS SHOWN	12'-6"	--
F2	10	#6	STR.	AS SHOWN	12'-6"	--
FE1	10	#6	BENT	AS SHOWN	12'-6"	--
FE2	14	#6	BENT	AS SHOWN	9'-6"	--
FS1	40	#6	BENT	EQUAL	19'-6"	--
P1	28	#4	BENT	EQUAL	8'-2"	--
P2	24	#4	BENT	EQUAL	8'-8"	--
PE1	10	#4	BENT	AS SHOWN	6'-2"	--
PE2	12	#4	BENT	AS SHOWN	6'-5"	--
PH1	18	#11	BENT	AS SHOWN	33'-1"	--
PH2	12	#5	STR.	EQUAL	29'-11"	--
PH3	10	#5	STR.	EQUAL	13'-11 1/2" AVG.	2'-9" TO 25'-2"
PH4	10	#8	BENT	AS SHOWN	30'-11"	--
S1	48	#6	BENT	EQUAL	18'-8" AVG.	15'-8" TO 21'-8"
S2	48	#6	BENT	EQUAL	17'-5" AVG.	15'-8" TO 19'-2"
S3	14	#6	BENT	1'-3" C/C	20'-5"	19'-6" TO 21'-4"
T1	1	#4	BENT	12" C/C	26'-3"	--
BAR LIST - 84" DRILLED SHAFT						
DS1	1	W-20	BENT	AS SHOWN	946'-6"	--
DV2	36	#11	BENT	AS SHOWN	30'-1"	--

①
▲

① LENGTH SHOWN INCLUDES 3'-8" FOR ONE LAP SPLICE. CONTRACTOR MAY ADD SPLICES AS NECESSARY, BUT PAYMENT WILL NOT BE MADE FOR EXTRA LENGTH REQUIRED. ADD 3'-8" FOR EACH SPLICE.

▲ NON-EPOXY COATED

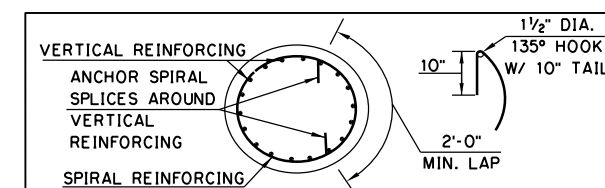

SPIRAL REINFORCING SPLICE DETAILS

NOTE: SPIRAL BARS SHALL CONFORM TO AASHTO M-32. SPIRAL BAR LENGTHS DO NOT INCLUDE LAP. IF LAP IS REQUIRED, THE LENGTH OF THE LAP SHALL BE AS SHOWN.

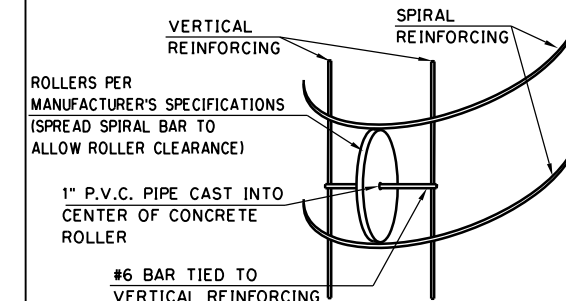

ROLLER INSTALLATION DETAIL

ROLLERS PER MANUFACTURER'S SPECIFICATIONS (SPREAD SPIRAL BAR TO ALLOW ROLLER CLEARANCE)



ROLLER PLACEMENT

ROLLER DETAILS

NOTE: REINFORCING CAGE CENTERING DEVICES SHALL CONSIST OF ROLLERS PLACED AT SPACING AS SHOWN AND HAVE THE CHARACTERISTICS AS INDICATED IN THE MANUFACTURER'S SPECIFICATIONS. SLAB BOLSTERS AND HIGH CHAIRS WILL BE ALLOWED BY THE DEPARTMENT.

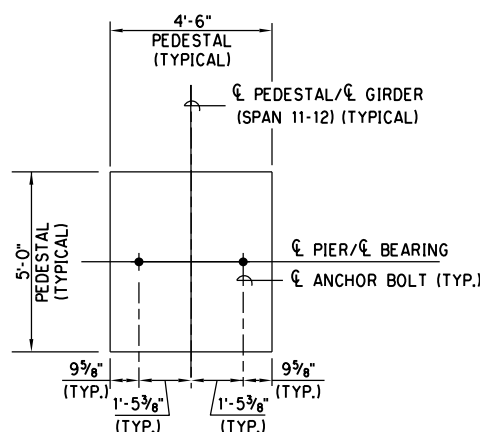

NOTE: GIRDER ϕ ARE ARCS. EACH PEDESTAL ϕ IS CONGRUENT WITH ITS GIRDER ϕ AT THE PIER ϕ .

ANCHOR BOLT LAYOUT

PIER NO. 11

(TYPICAL)

NOTE: DIMENSIONS SHOWN ARE PERPENDICULAR TO PEDESTALS. FOR FURTHER INFORMATION SEE "BEARING ASSEMBLY DETAILS", SHEET.

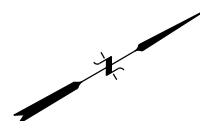

3/1/2024 3:20:27 PM H:\PROJECTS\2789_CrossRoads_Phase 4\Bridges\Drawings\Ph4 Bridges\Bridges\A\0903208 P4 Bridge A Piers.dgn

DESIGN		PHASE 4	OKLAHOMA COUNTY
DRAWN		BRIDGE "A"	RAMP "A" AT I-35 & I-240 INTERCHANGE
CHECKED		PIER DETAILS PIER NO. 11 (SHEET 3 OF 3)	
APPROVED			
SQUAD	POE		
		STATE JOB NO. 09032(08)	SHEET NO. 026

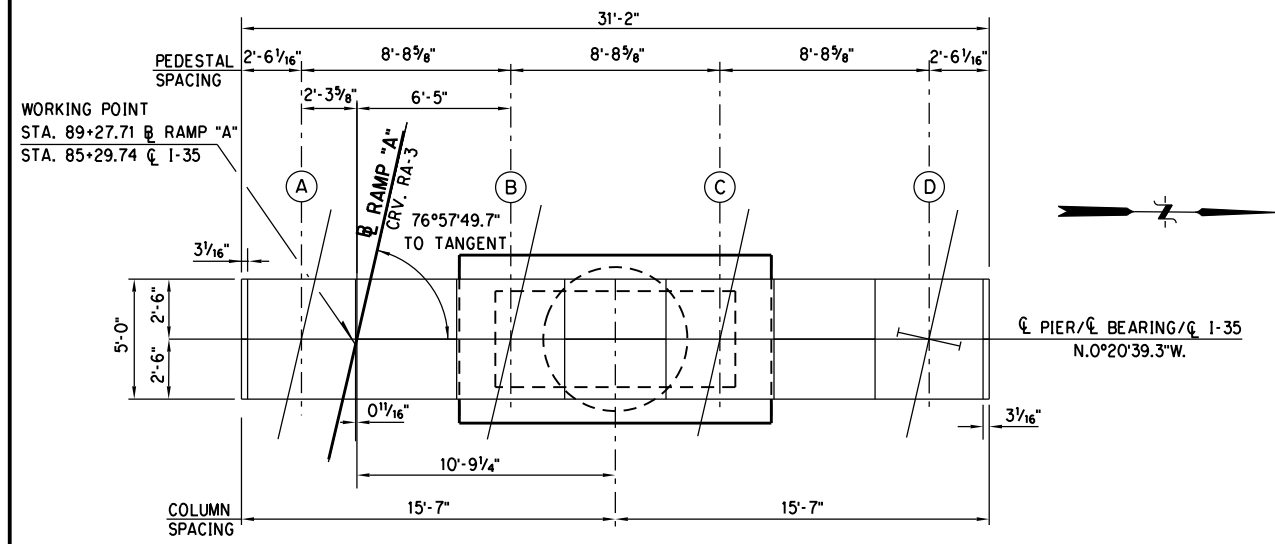

PEDESTAL ELEVATION SCHEDULE - PIER NO. 13

PEDESTAL	A	B	C	D
SPAN 13-14 ELEV.	1300.17	1300.62	1301.07	1301.52

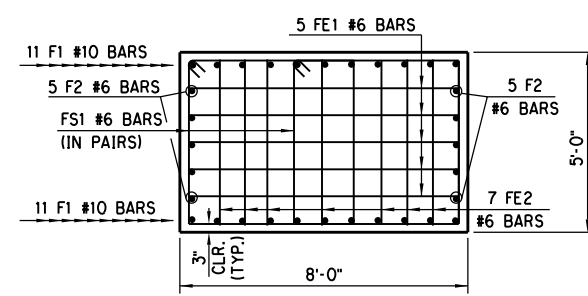
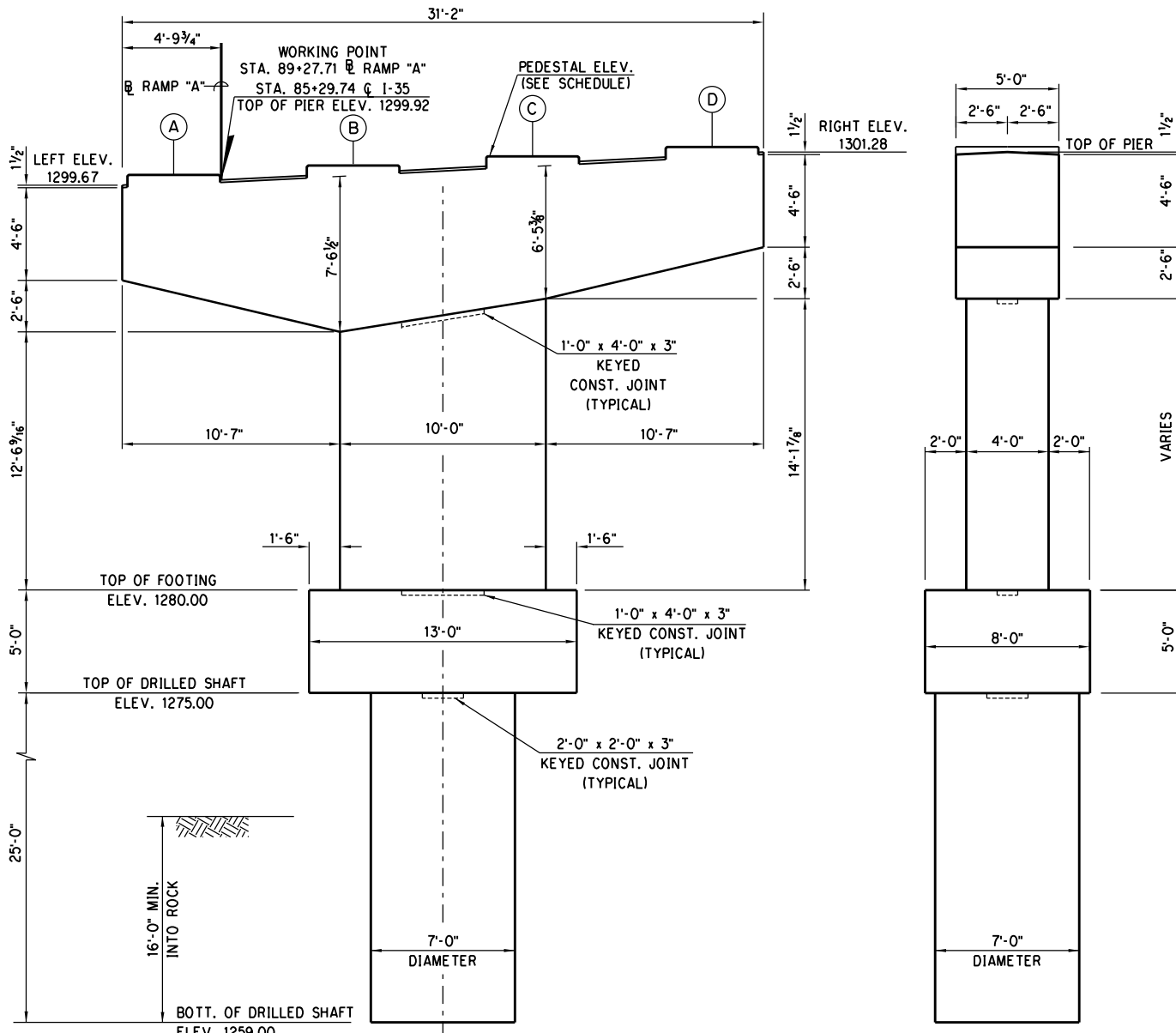
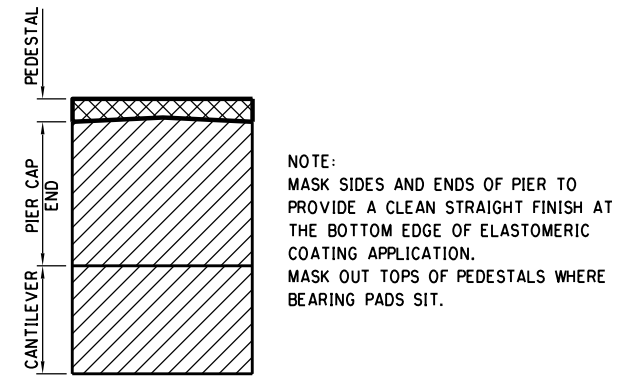
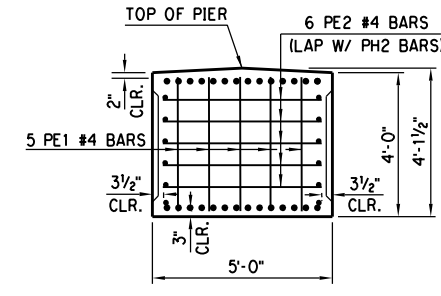
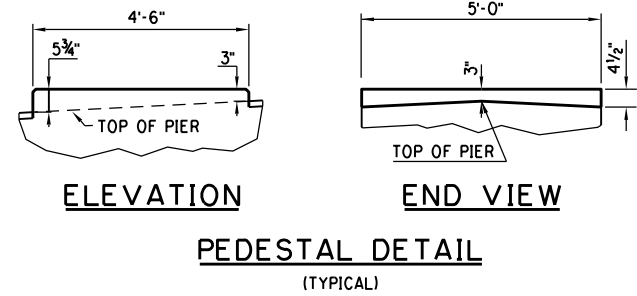

PIER NO. 13 - QUANTITIES

ITEM	UNIT	TOTAL
SUBSTRUCTURE EXCAVATION COMMON	C.Y.	55.00
CLASS A CONCRETE	C.Y.	78.70
EPOXY COATED REINFORCING STEEL	LB.	17,170.00
WATER REPELLENT (VISUALLY INSPECTED)	S.Y.	55.00
DRILLED SHAFTS 84" DIAMETER	L.F.	25.00
ELASTOMERIC COATING	S.F.	200.00

PHASE 4 OKLAHOMA COUNTY
BRIDGE "A" RAMP "A" AT I-35 & I-240 INTERCHANGE

DESIGN
DRAWN
CHECKED
APPROVED
SQUAD POE

PIER DETAILS
PIER NO. 13
(SHEET 1 OF 3)

STATE JOB NO. 09032(08) SHEET NO. B027

3/1/2024 3:20:29 PM H:\PROJECTS\2789_CrossRoads_Phase 4\Bridges\Drawings\Phase 4\Bridges\Bridges\Phase 4\Bridges A Piers.dgn

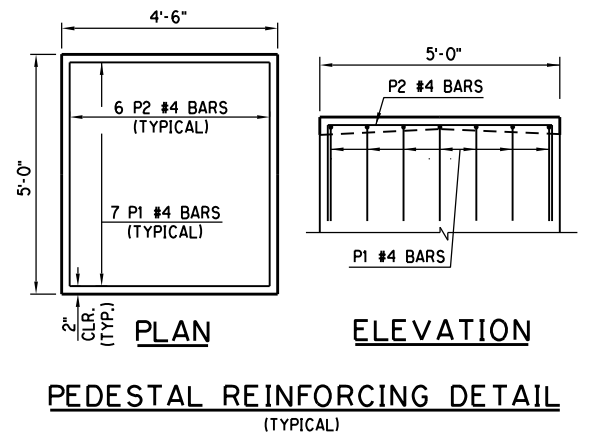
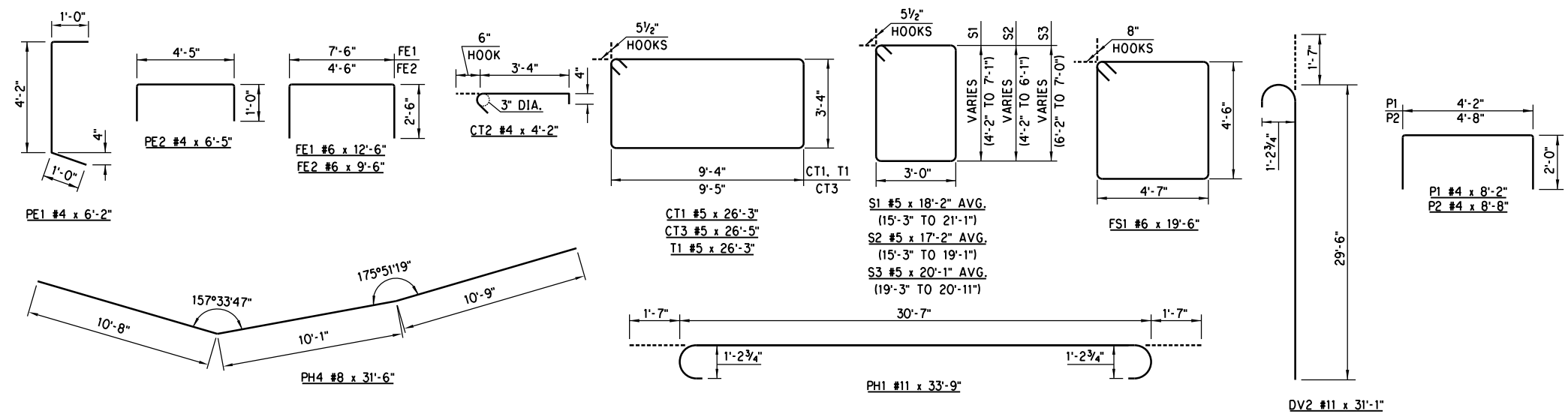

ALL BENT BAR DIMENSIONS ARE OUT TO OUT.

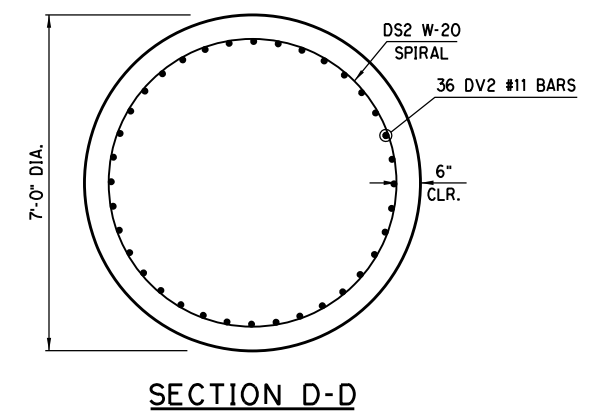
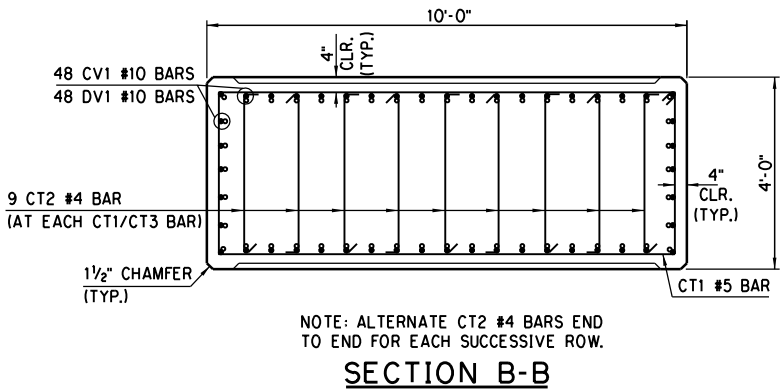
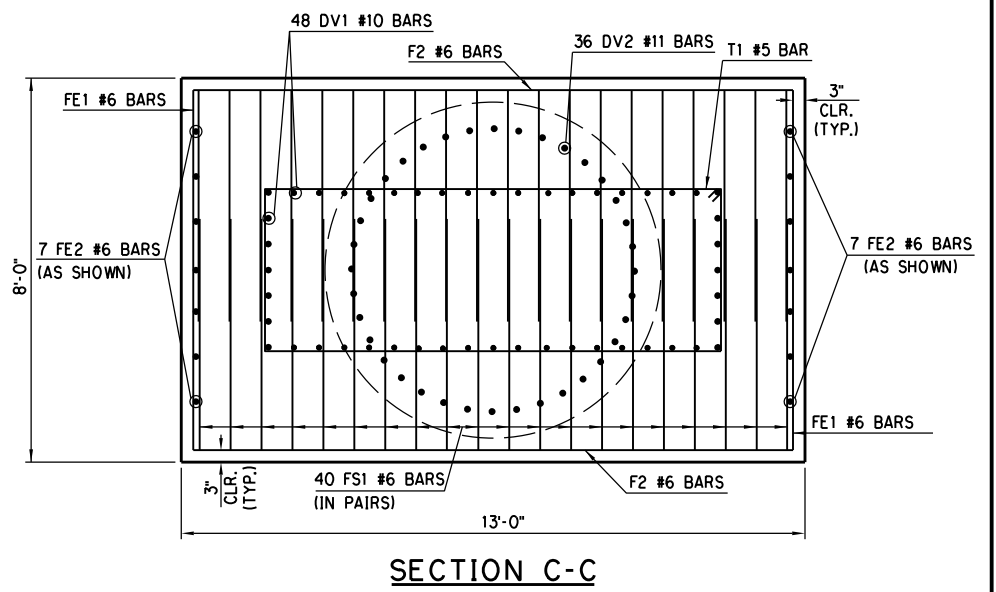
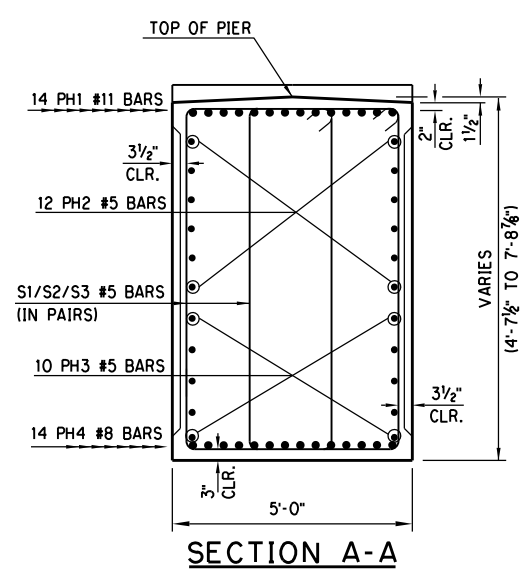
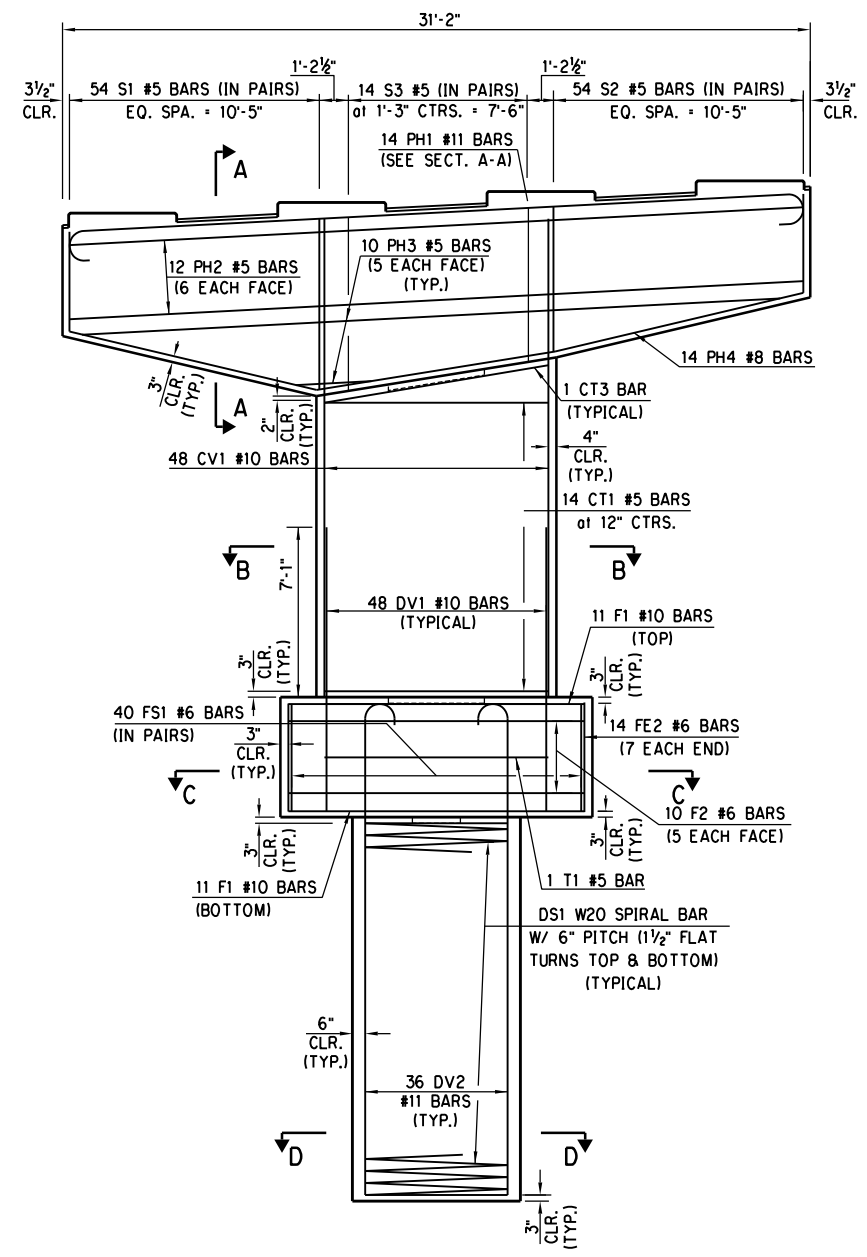

NOTE: ALTERNATE CT2 #4 BARS END TO END FOR EACH SUCCESSIVE ROW.

3/1/2024 3:20:31 PM H:\PROJECTS\2789_CrossRoads_Phase 4\Bridges\Ph4 Bridges\Bridg A\0903208 P4 Bridge A Piers.dgn

DESIGN		PHASE 4	OKLAHOMA COUNTY
DRAWN		BRIDGE "A"	RAMP "A" AT I-35 & I-240 INTERCHANGE
CHECKED		PIER DETAILS	
APPROVED			
SQUAD	POE	PIER NO. 13 (SHEET 2 OF 3)	
		STATE JOB NO. 09032(08)	SHEET NO. B028

**BAR LIST - PIER NO. 13
(EPOXY COATED)**

MARK	NO.	SIZE	FORM	SPACING	LENGTH	LENGTH VARIATION
CT1	14	#5	BENT	12" C/C	26'-3"	--
CT2	135	#4	BENT	AS SHOWN	4'-2"	--
CT3	1	#5	BENT	AS SHOWN	26'-5"	--
CV1	48	#10	STR.	AS SHOWN	19'-11"	--
DV1	48	#10	STR.	AS SHOWN	11'-10"	--
F1	22	#10	STR.	AS SHOWN	12'-6"	--
F2	10	#6	STR.	AS SHOWN	12'-6"	--
FE1	10	#6	BENT	AS SHOWN	12'-6"	--
FE2	14	#6	BENT	AS SHOWN	9'-6"	--
FS1	40	#6	BENT	EQUAL	19'-6"	--
P1	28	#4	BENT	EQUAL	8'-2"	--
P2	24	#4	BENT	EQUAL	8'-8"	--
PE1	10	#4	BENT	AS SHOWN	6'-2"	--
PE2	12	#4	BENT	AS SHOWN	6'-5"	--
PH1	14	#11	BENT	AS SHOWN	33'-9"	--
PH2	12	#5	STR.	EQUAL	30'-7"	--
PH3	10	#5	STR.	EQUAL	14'-5" AVG.	3'-0" TO 25'-10"
PH4	14	#8	BENT	AS SHOWN	31'-6"	--
S1	54	#5	BENT	EQUAL	18'-2" AVG.	15'-3" TO 21'-1"
S2	54	#5	BENT	EQUAL	17'-2" AVG.	15'-3" TO 19'-1"
S3	14	#5	BENT	1'-3" C/C	20'-1" AVG.	19'-3" TO 20'-11"
T1	1	#4	BENT	12" C/C	26'-3"	--

BAR LIST - 84" DRILLED SHAFT

DS1	1	W-20	BENT	AS SHOWN	984'-2"	--
DV2	36	#11	BENT	AS SHOWN	31'-11"	--

① LENGTH SHOWN INCLUDES 3'-8" FOR ONE LAP SPLICE. CONTRACTOR MAY ADD SPLICES AS NECESSARY, BUT PAYMENT WILL NOT BE MADE FOR EXTRA LENGTH REQUIRED. ADD 3'-8" FOR EACH SPLICE.

▲ NON-EPOXY COATED

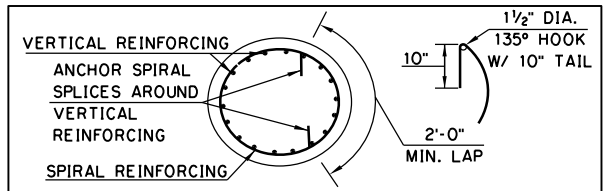

SPIRAL REINFORCING SPLICE DETAILS

NOTE: SPIRAL BARS SHALL CONFORM TO AASHTO M-32. SPIRAL BAR LENGTHS DO NOT INCLUDE LAP. IF LAP IS REQUIRED, THE LENGTH OF THE LAP SHALL BE AS SHOWN.

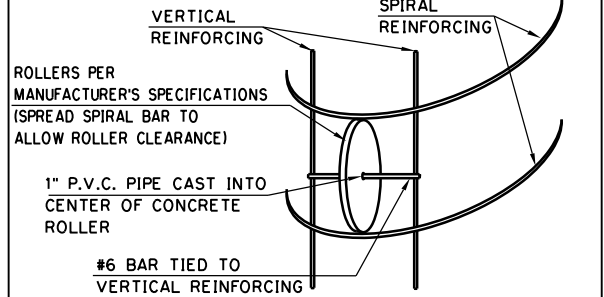

ROLLER INSTALLATION DETAIL

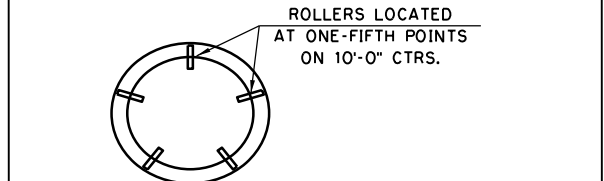

ROLLER PLACEMENT

ROLLER DETAILS

NOTE: REINFORCING CAGE CENTERING DEVICES SHALL CONSIST OF ROLLERS PLACED AT SPACING AS SHOWN AND HAVE THE CHARACTERISTICS AS INDICATED IN THE MANUFACTURER'S SPECIFICATIONS. SLAB BOLSTERS AND HIGH CHAIRS WILL BE ALLOWED BY THE DEPARTMENT.

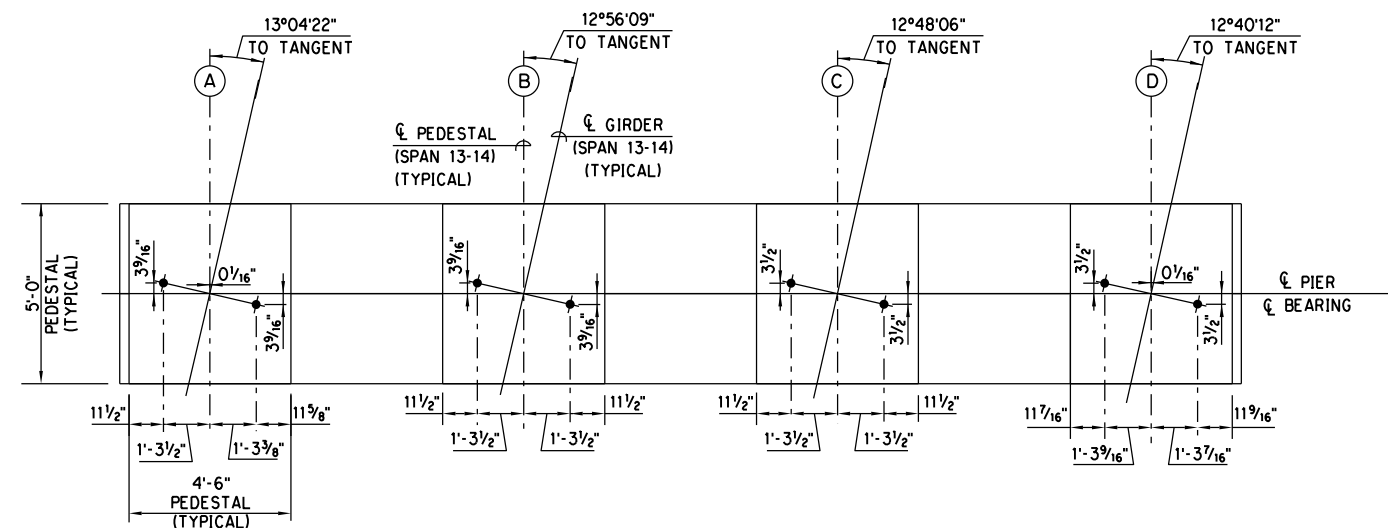

NOTE: GIRDER ϕ ARE ARCS.
GIRDERS "A" AND "D" ϕ ARE OFFSET FROM PEDESTAL ϕ AS NOTED.

**ANCHOR BOLT LAYOUT
PIER NO. 13**

NOTE: DIMENSIONS SHOWN ARE PERPENDICULAR TO PEDESTALS.
FOR FURTHER INFORMATION SEE "BEARING ASSEMBLY DETAILS", SHEET.

DESIGN		PHASE 4	OKLAHOMA COUNTY
DRAWN		BRIDGE "A"	RAMP "A" AT I-35 & I-240 INTERCHANGE
CHECKED		PIER DETAILS PIER NO. 13 (SHEET 3 OF 3)	
APPROVED			
SQUAD	POE	STATE JOB NO. 09032(08)	SHEET NO. B029

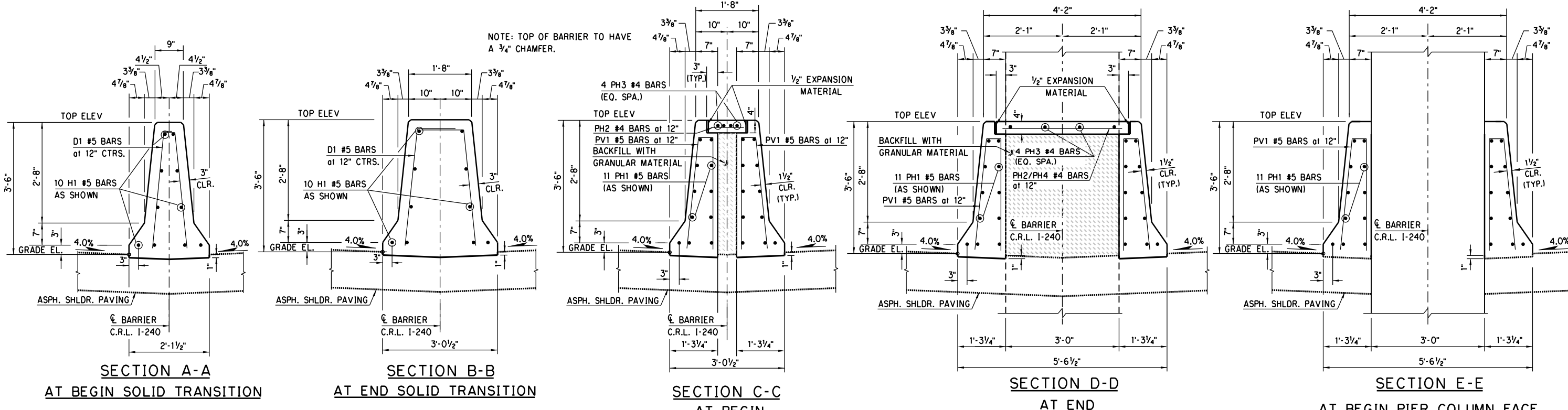
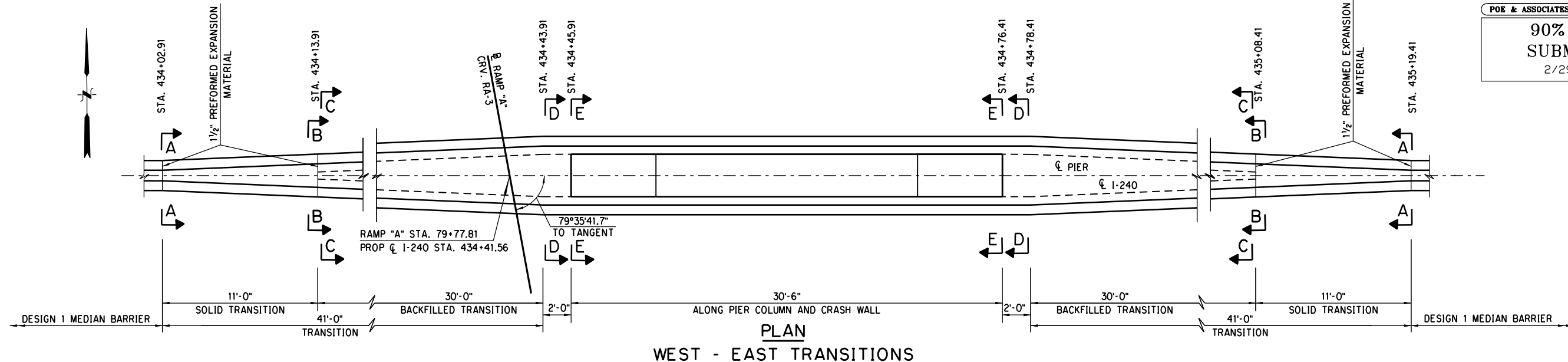

NOTE: TOP OF BARRIER TO HAVE A 3/4" CHAMFER.

BAR LIST EPOXY COATED						
SOLID TRANSITION						
MARK	NO.	SIZE	FORM	SPACING	LENGTH	LENGTH VARIATION
D1	48	#5	BNT.	12" C/C	3'-11 1/2" AVG.	3'-6" TO 4'-5"
H1	20	#5	STR.	AS SHOWN	10'-8"	--
GRANULAR BACKFILLED TRANSITION						
MARK	NO.	SIZE	FORM	SPACING	LENGTH	LENGTH VARIATION
PV1	190	#5	BNT.	12" c/c	6'-8"	--
PH1	22	#5	STR.	AS SHOWN	97'-0"	--
PH2	62	#4	STR.	12" C/C	1'-11" AVG.	8" TO 3'-2"
PH3	4	#4	STR.	EQ. SPA.	31'-6"	--
PH4	4	#4	STR.	EQ. SPA.	3'-2"	--

① LENGTH INCLUDES LAP:
PH1 - 2 at 2'-0"
(STAGGER ALL LAPS)

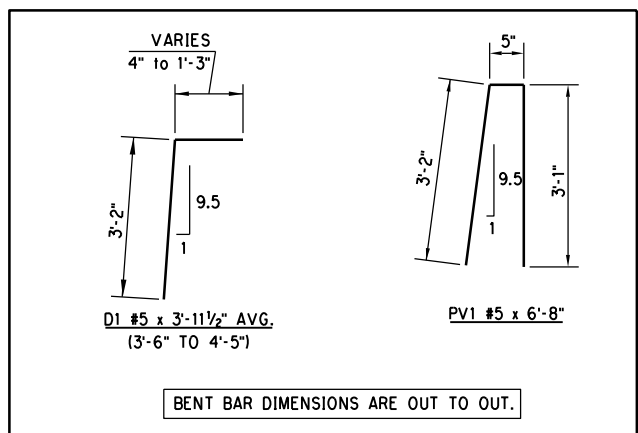

QUANTITIES		
ITEM	UNIT	TOTAL
CLASS A CONCRETE	C.Y.	26.30
EPOXY COATED REINFORCING STEEL	LB.	4,140.00

NOTE: ALL COST OF GRANULAR BACKFILL TO BE INCLUDED IN OTHER ITEMS OF WORK

BARRIER ELEVATION SCHEDULE		
STATION	TOP	GRADE
434+02.91	1300.60	1297.10
434+13.91	1300.39	1296.89
434+43.91	1299.86	1296.36
443+45.91	1299.82	1296.32
434+76.41	1299.30	1295.80
434+78.41	1299.27	1295.77
435+08.41	1298.77	1295.27
435+19.41	1298.60	1295.10

PHASE 4 OKLAHOMA COUNTY
BRIDGE "A" RAMP "A" AT I-35 & I-240 INTERCHANGE

**PIER PROTECTION AND
BARRIER TRANSITION DETAILS**
PIER NO. 6

STATE JOB NO. 09032108 SHEET NO. B030

DESIGN	
DRAWN	
CHECKED	
APPROVED	
SQUAD	POE

3/1/2024 3:20:35 PM H:\PROJECTS\2789_CrossRoads_Phase 4\Bridges\Drawings\Phase 4\Bridges\Bridges\Phase 4\Bridges A Pier 6 Protect.dgn

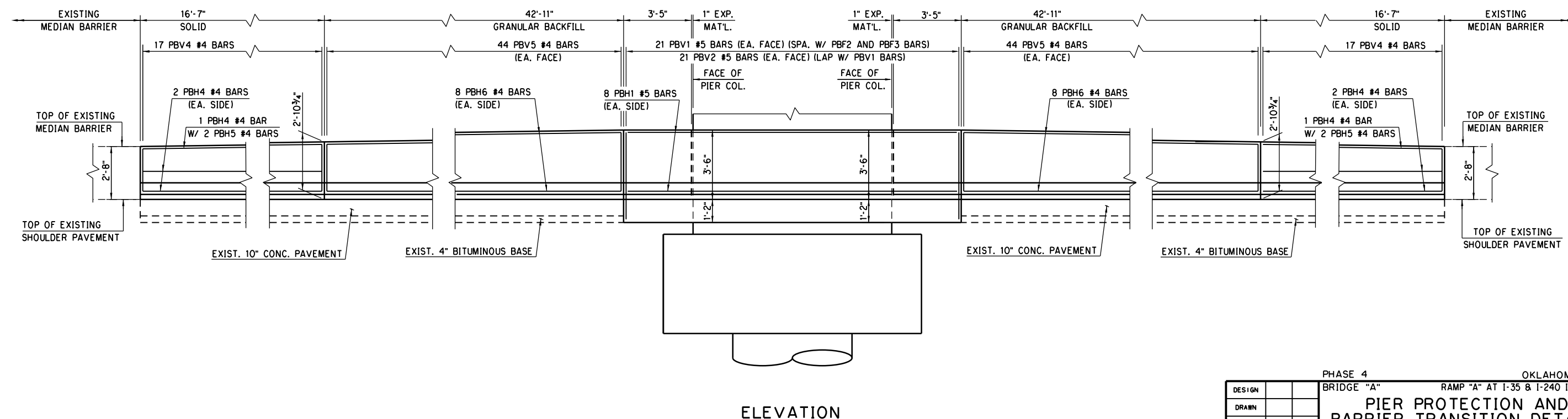
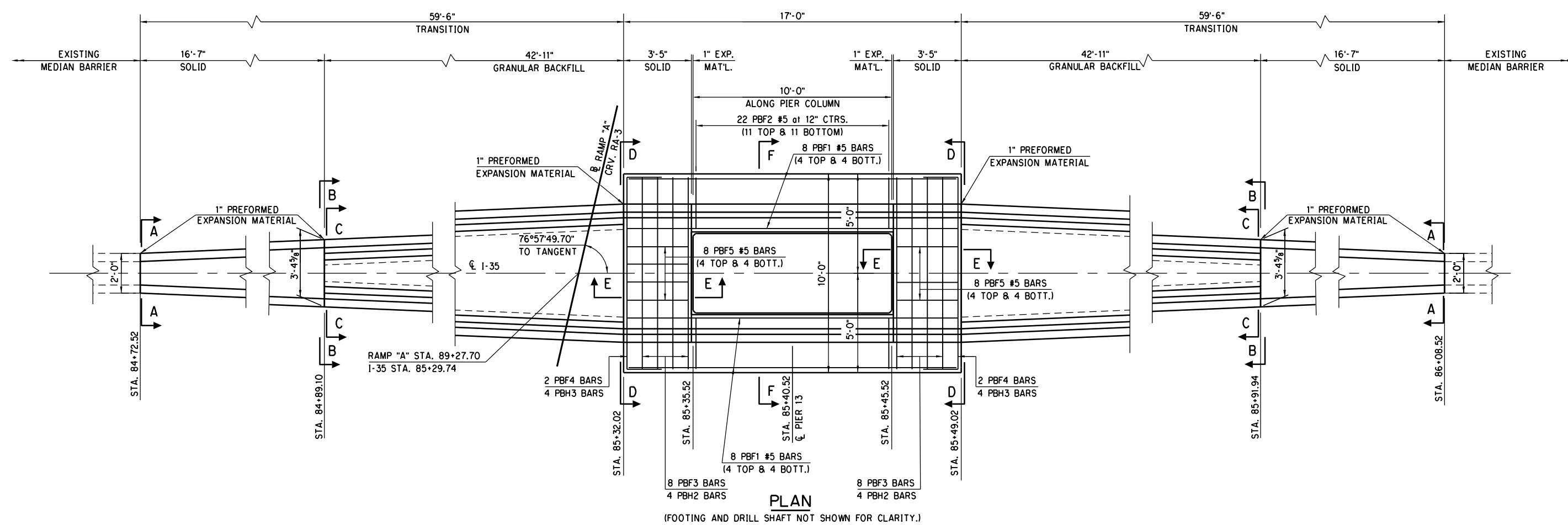

ELEVATION

DESIGN		PHASE 4	OKLAHOMA COUNTY
DRAWN		BRIDGE "A"	BRIDGE "A" AT I-35 & I-240 INTERCHANGE
CHECKED		PIER PROTECTION AND BARRIER TRANSITION DETAILS	
APPROVED			
SQUAD	POE	PIER NO. 13 (SHEET 1 OF 3)	
		STATE JOB NO. 09032(08)	SHEET NO. B031

* NOTE: AN EXPANSION JOINT IS LOCATED 12" FROM C 1-35.
MAINTAIN 6" CLEARANCE WHEN INSTALLING DOWELS FROM
STATION 84+89.10 TO 85+32.02 AND STATION 85+49.02 TO 85+91.94.

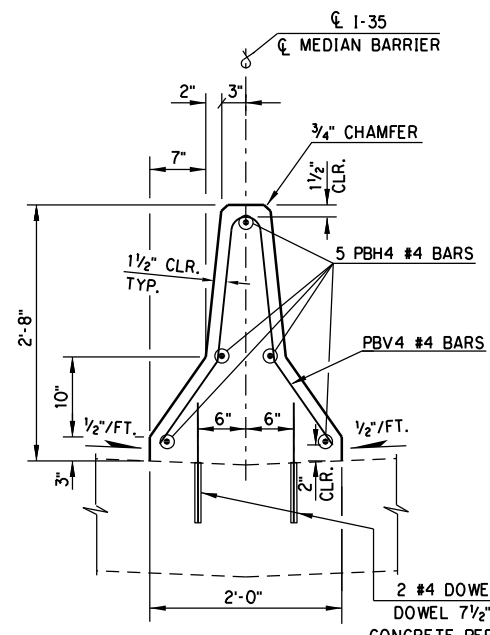

SECTION A-A
SOLID TRANSITION

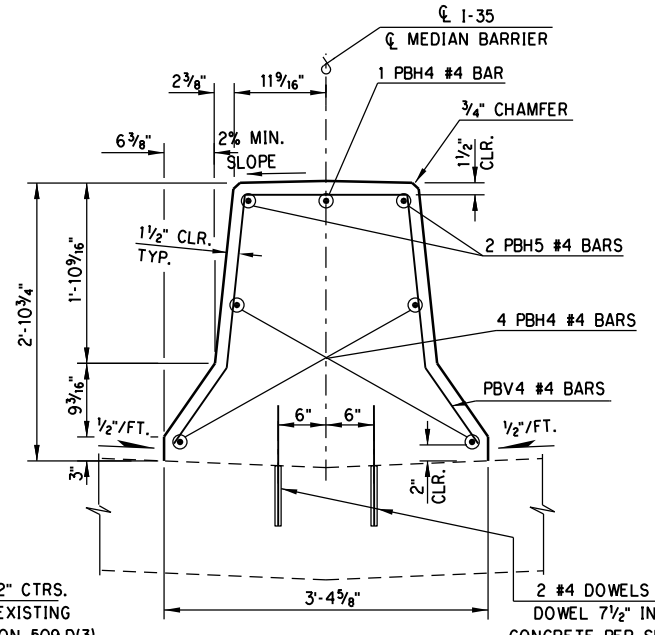

SECTION B-B
SOLID TRANSITION

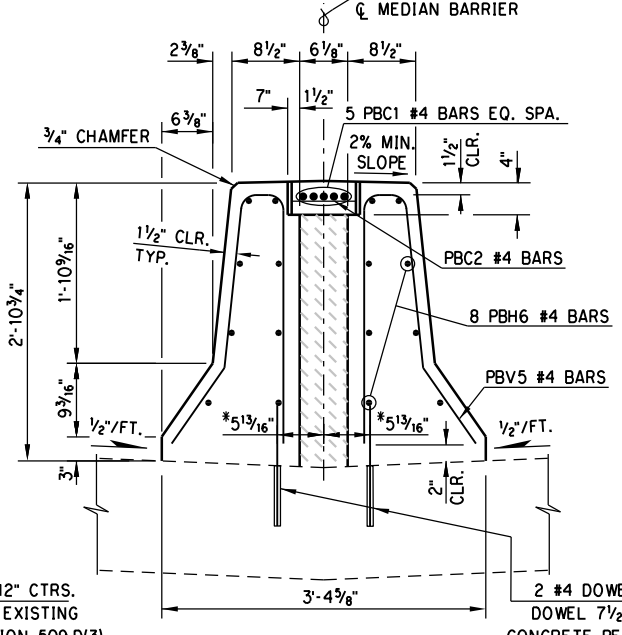

SECTION C-C
GRANULAR BACKFILLED TRANSITION

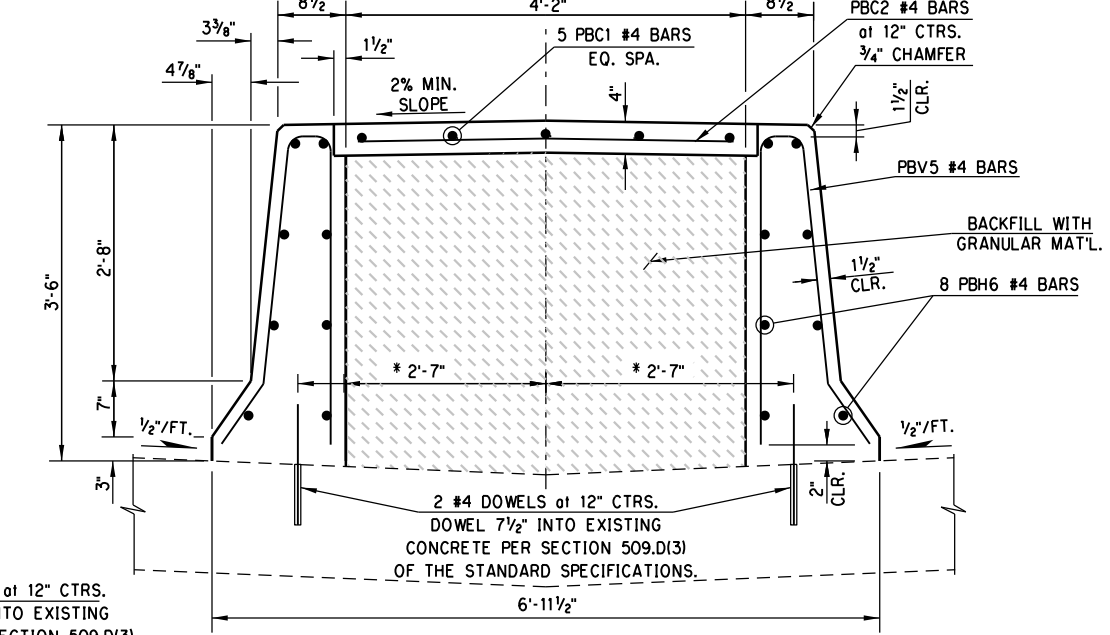

SECTION D-D
GRANULAR BACKFILLED TRANSITION

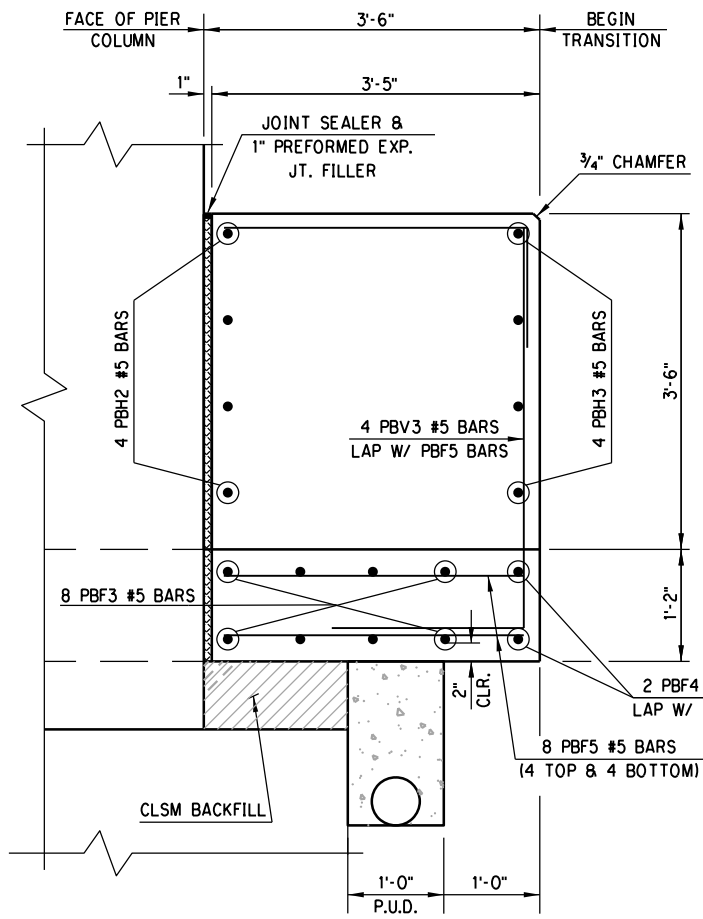

SECTION E-E
AT END PIER COLUMN FACE

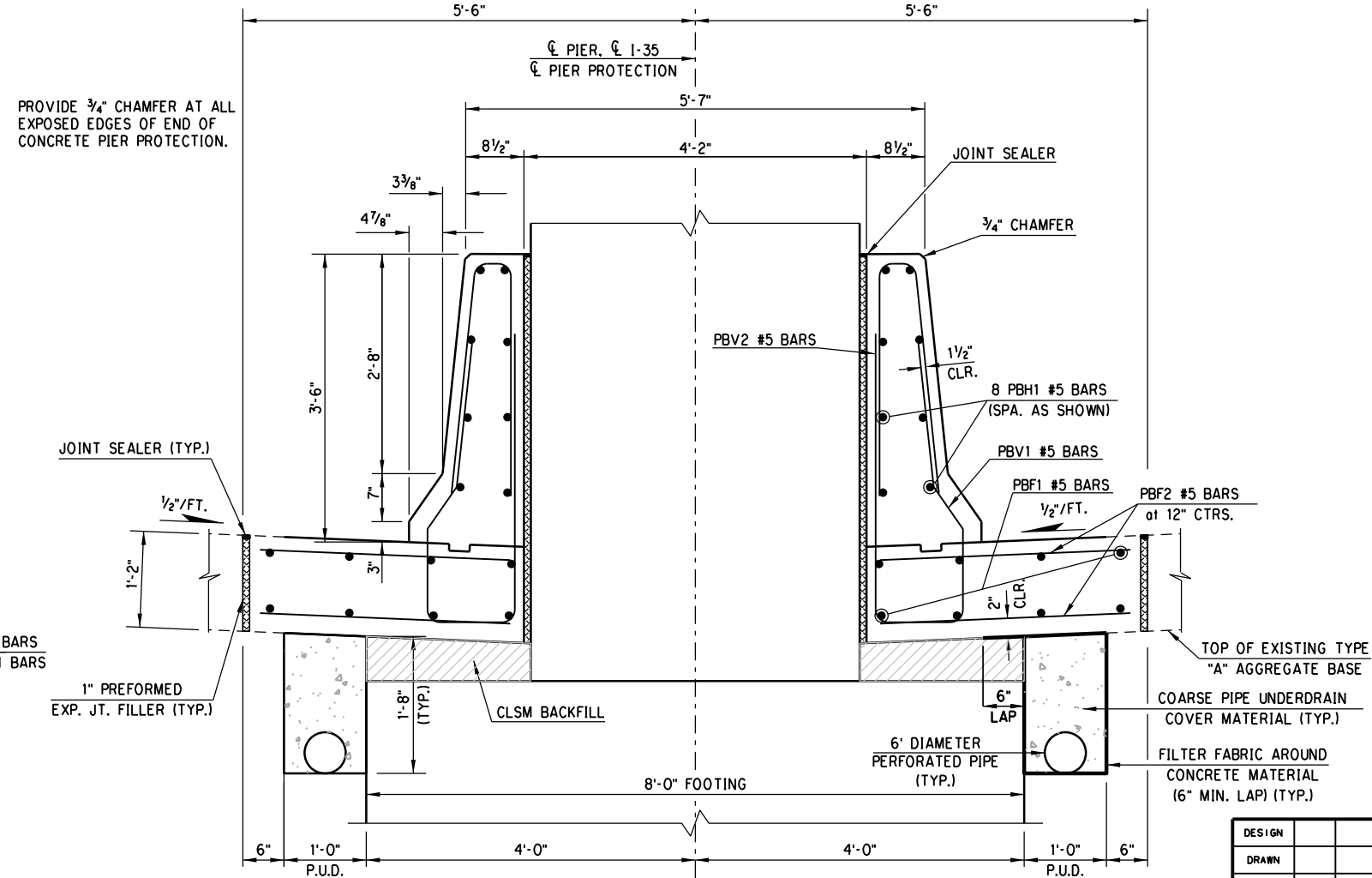

SECTION F-F
AT PIER COLUMN

PROVIDE 3/4" CHAMFER AT ALL EXPOSED EDGES OF END OF CONCRETE PIER PROTECTION.

TOP OF EXISTING TYPE "A" AGGREGATE BASE
COARSE PIPE UNDERDRAIN COVER MATERIAL (TYP.)
6" DIAMETER PERFORATED PIPE (TYP.)
FILTER FABRIC AROUND CONCRETE MATERIAL (6" MIN. LAP) (TYP.)

DESIGN		PHASE 4	OKLAHOMA COUNTY
DRAWN		BRIDGE "A"	RAMP "A" AT I-35 & I-240 INTERCHANGE
CHECKED		PIER PROTECTION AND BARRIER TRANSITION DETAILS	
APPROVED		PIER NO. 13 (SHEET 2 OF 3)	
SQUAD	POE	STATE JOB NO. 09032108	SHEET NO. B032

3/1/2024 3:20:38 PM H:\PROJECTS\2789_CrossRoads_Phase 4\Bridges\Drawings\Ph4 Bridges\A Pier\3 ProtectTransition.dgn

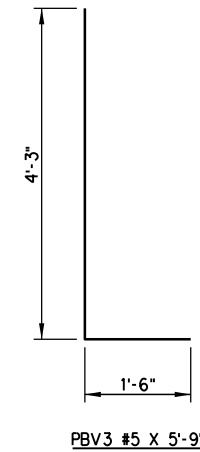
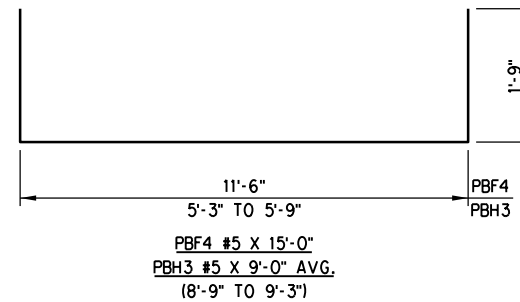
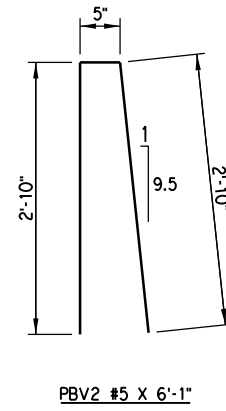
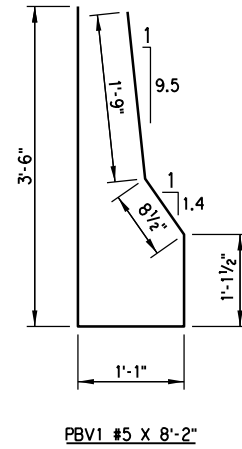
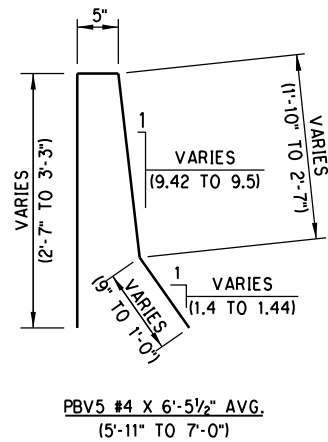
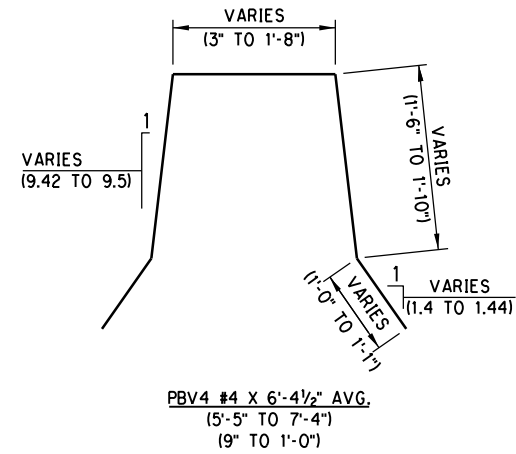

BAR LIST						
EPOXY COATED						
MARK	NO.	SIZE	FORM	SPACING	LENGTH	LENGTH VARIATION
PBC1	10	#4	STR.	AS SHOWN	13'-2"	--
PBC2	88	#4	STR.	12" C/C	2'-0 1/2" AVG.	3" TO 3'-10"
PBF1	16	#5	STR.	AS SHOWN	16'-8"	--
PBF2	44	#5	STR.	AS SHOWN	3'-1"	--
PBF3	16	#5	STR.	EQ. SPA.	9'-8"	--
PBF4	4	#5	BNT.	AS SHOWN	15'-0"	--
PBF5	16	#5	STR.	AS SHOWN	3'-1"	--
PBH1	16	#5	STR.	AS SHOWN	16'-8"	--
PBH2	8	#5	STR.	AS SHOWN	5'-6" AVG.	5'-3" TO 5'-9"
PBH3	8	#5	BNT.	AS SHOWN	9'-0" AVG.	8'-9" TO 9'-3"
PBH4	10	#4	STR.	AS SHOWN	16'-2"	--
PBH5	4	#4	STR.	AS SHOWN	8'-3"	--
PBH6	16	#4	STR.	AS SHOWN	42'-6"	--
PBV1	42	#5	BNT.	12" C/C	8'-2"	--
PBV2	42	#5	BNT.	12" C/C	6'-1"	--
PBV3	8	#5	STR.	AS SHOWN	5'-9"	--
PBV4	34	#4	BNT.	AS SHOWN	6'-4 1/2" AVG.	5'-5" TO 7'-4"
PBV5	176	#4	BNT.	AS SHOWN	6'-5 1/2" AVG.	5'-11" TO 7'-0"

QUANTITIES		
ITEM	UNIT	TOTAL
CLASS A CONCRETE	C.Y.	41.00
EPOXY COATED REINFORCING STEEL	LB.	3,470.00
6" PERFORATED PIPE UNDERDRAIN ROUND	L.F.	46.00

NOTE: COST OF SAWCUTTING, REMOVAL OF EXISTING MEDIAN BARRIER, PAVEMENT REMOVAL, EXCAVATION, GRANULAR BACKFILL, APPROXIMATELY 1.0 C.Y. OF CLSM BACKFILL, JOINT FILLER AND JOINT SEALER ARE INCLUDED IN OTHER ITEMS OF WORK.

BENT BAR DIMENSIONS ARE OUT TO OUT.

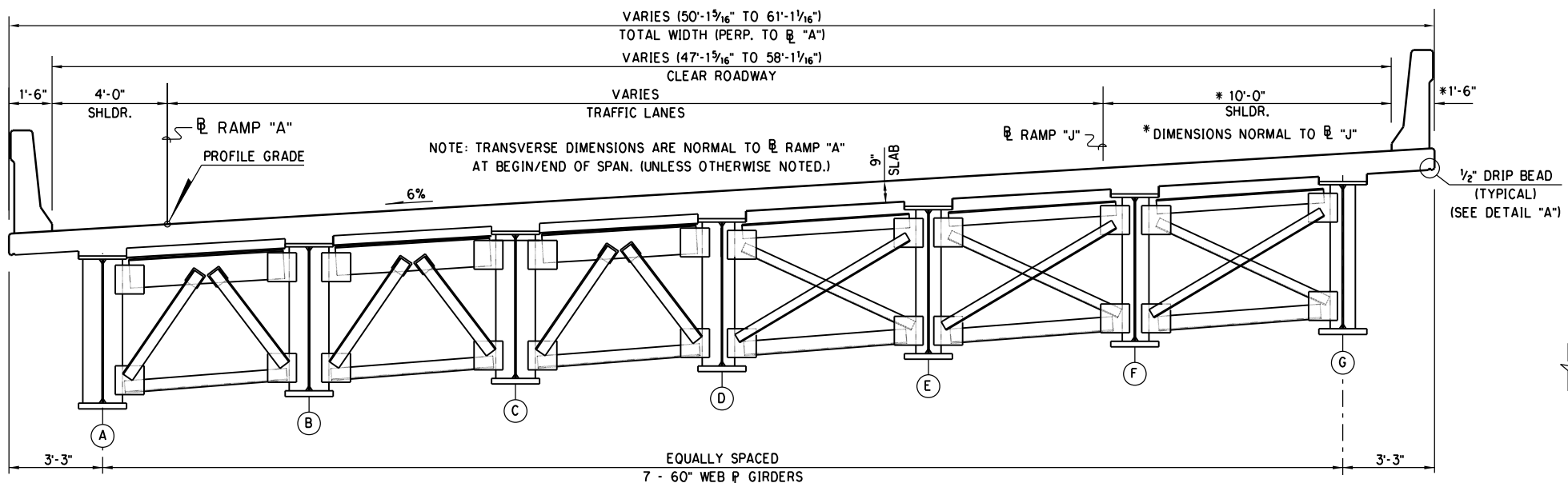

TYPICAL BRIDGE SECTION
(SPAN 7)

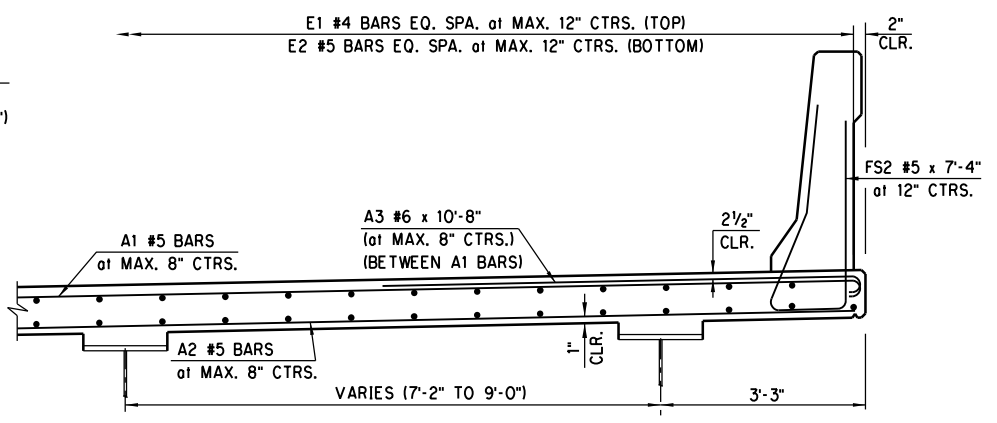

TYPICAL BRIDGE REINFORCING SECTION
(SPAN 7)

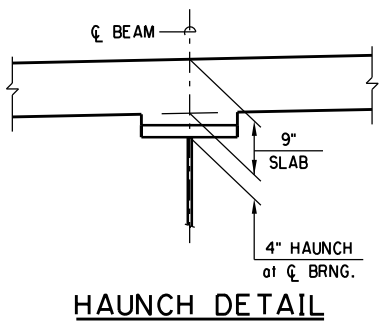
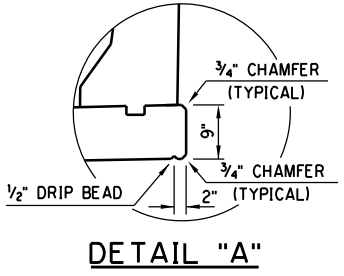

WATER REPELLENT SURFACE TREATMENT

SURFACES INDICATED WITH HEAVY LINES SHALL BE TREATED WITH A PENETRATING WATER REPELLENT SEALER.

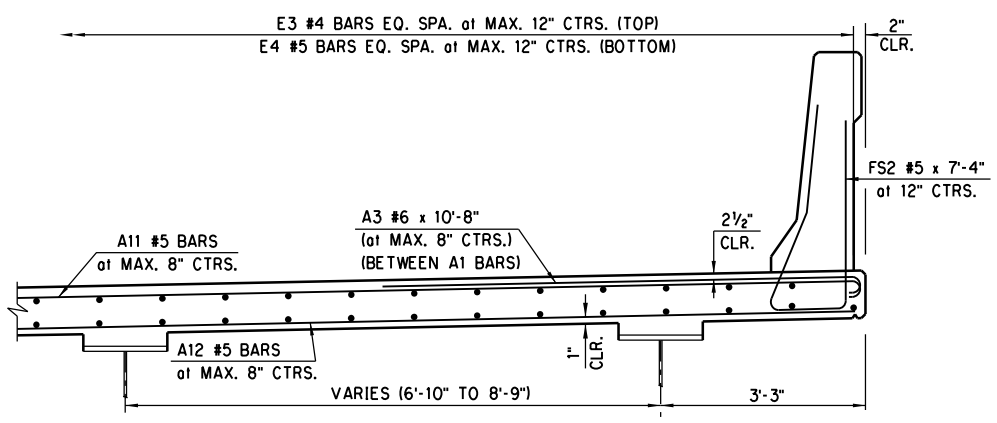

TYPICAL BRIDGE REINFORCING SECTION
(SPAN 8)

SUPERSTRUCTURE QUANTITIES

ITEM	UNIT	TOTAL
SAW-CUT GROOVING	S.Y.	4,581.00
42" F-SHAPED PARAPET	L.F.	2,165.80
STRUCTURAL STEEL M270 GRADE 50W	LB.	2,566,130.00
STAINLESS STEEL FIXED BEARING ASSEMBLY	EA.	28.00
STAINLESS STEEL EXP. BEARING ASSEMBLY	EA.	40.00
** CLASS AA CONCRETE	C.Y.	1,301.80
EPOXY COATED REINFORCING STEEL	LB.	322,370.00
WATER REPELLENT (VISUALLY INSPECTED)	S.Y.	2,715.00
SEALED EXPANSION JOINT	L.F.	195.39
SEALER CRACK PREPARATION	L.F.	200.00
SEALER RESIN	GAL.	2.20

** NOTE:
PLAN QUANTITY FOR CLASS "AA" CONCRETE INCLUDES 59.10 C.Y. FOR HAUNCHES OVER GIRDERS. THE HAUNCH HEIGHTS WILL BE SET AFTER ERECTION OF GIRDERS TO PROVIDE FOR DEAD LOAD DEFLECTION AND GRADE ADJUSTMENT, BUT THE PAY QUANTITY FOR HAUNCHES WILL BE AS SHOWN ABOVE.

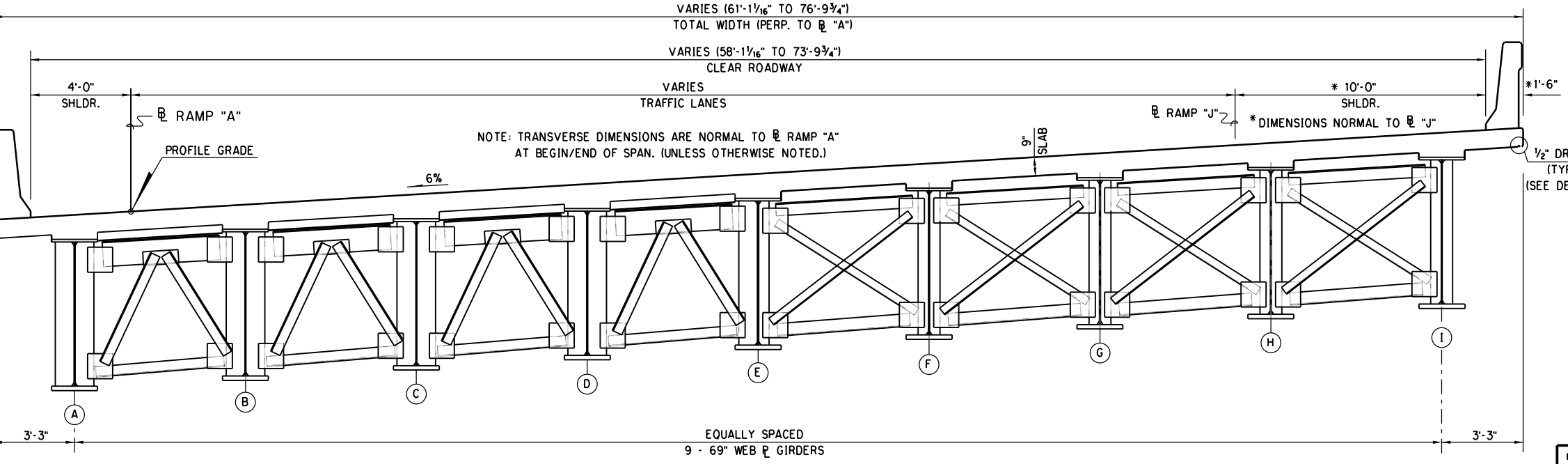

TYPICAL BRIDGE SECTION
(SPAN 8)

DESIGN		PHASE 4	OKLAHOMA COUNTY
DRAWN		BRIDGE "A"	RAMP "A" AT I-35 & I-240 INTERCHANGE
CHECKED		SUPERSTRUCTURE DETAILS SPAN 7 AND 8 SECTIONS (SHEET 1 OF 7) STATE JOB NO. 09032108 SHEET NO. B034	
APPROVED			
SQUAD	POE		

3/1/2024 3:20:42 PM H:\PROJECTS\2789_CrossRoads_Phase 4 Bridge Drawings\Phase 4 Bridge A SUPER.dgn

90% PLAN
SUBMITTAL
2/29/2024

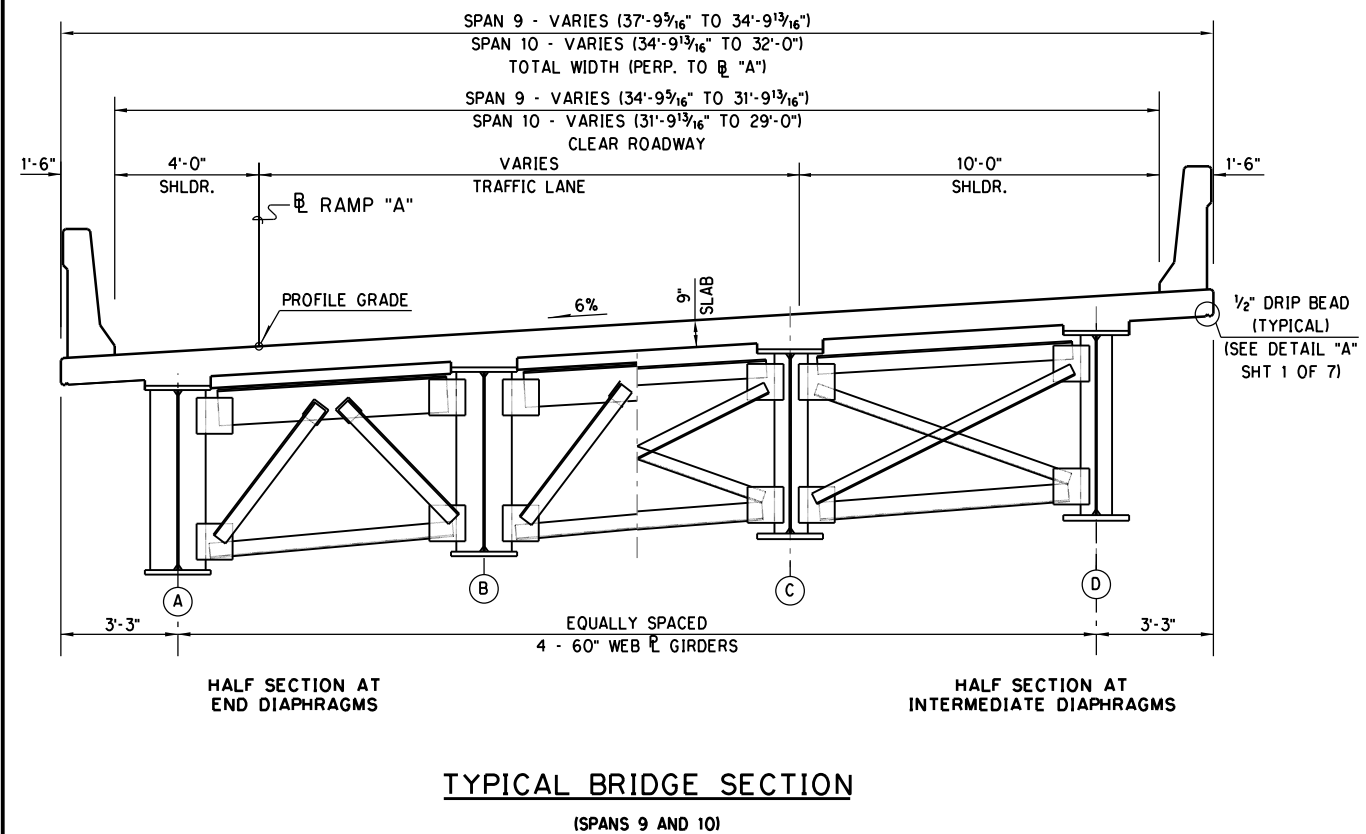

NOTE: FOR BAR BEND DETAILS SEE SHEET 3 OF 7.

BAR LIST - SUPERSTRUCTURE						
EPOXY COATED						
MARK	NO.	SIZE	FORM	SPACING	LENGTH	LENGTH VARIATION
①	A1	180	#5 BNT.	7 $\frac{3}{8}$ " C/C	55'-5 $\frac{1}{2}$ " AVG.	50'-11" TO 60'-0"
①	A2	200	#5 STR.	7 $\frac{3}{8}$ " C/C	54'-10 $\frac{1}{2}$ " AVG.	49'-9" TO 60'-0"
	A3	3358	#6 BNT.	AS SHOWN	10'-8"	--
① ②	A4	28	#5 BNT.	7 $\frac{3}{8}$ " C/C	63'-4 $\frac{1}{2}$ " AVG.	62'-7" TO 64'-2"
① ②	A5	8	#5 STR.	7 $\frac{3}{8}$ " C/C	62'-9 $\frac{1}{2}$ " AVG.	62'-7" TO 63'-0"
①	A6	2	#5 BNT.	7 $\frac{3}{8}$ " C/C	40'-7 $\frac{1}{2}$ " AVG.	29'-7" TO 51'-8"
①	A7	2	#5 STR.	7 $\frac{3}{8}$ " C/C	40'-0 $\frac{1}{2}$ " AVG.	29'-0" TO 51'-1"
①	A8	7	#5 BNT.	7 $\frac{3}{8}$ " C/C	26'-1 $\frac{1}{2}$ " AVG.	6'-1" TO 46'-2"
①	A9	7	#5 STR.	7 $\frac{3}{8}$ " C/C	25'-6 $\frac{1}{2}$ " AVG.	5'-6" TO 45'-7"
	A10	1	#6 BNT.	AS SHOWN	9'-2"	--
① ②	A11	238	#5 BNT.	7 $\frac{3}{8}$ " C/C	72'-4" AVG.	64'-9" TO 79'-11"
① ②	A12	238	#5 STR.	7 $\frac{3}{8}$ " C/C	71'-2" AVG.	63'-7" TO 78'-9"
① ②	A13	2	#5 BNT.	7 $\frac{3}{8}$ " C/C	72'-2" AVG.	67'-6" TO 76'-10"
① ②	A14	2	#5 STR.	7 $\frac{3}{8}$ " C/C	71'-7" AVG.	66'-11" TO 73'-3"
①	A15	7	#5 BNT.	7 $\frac{3}{8}$ " C/C	30'-3" AVG.	4'-8" TO 55'-10"
①	A16	7	#5 STR.	7 $\frac{3}{8}$ " C/C	29'-8" AVG.	4'-1" TO 55'-3"
	A17	1	#6 BNT.	AS SHOWN	8'-11"	--
①	A18	9	#5 BNT.	7 $\frac{3}{8}$ " C/C	30'-7 $\frac{1}{2}$ " AVG.	4'-3" TO 57'-0"
①	A19	9	#5 STR.	7 $\frac{3}{8}$ " C/C	30'-0 $\frac{1}{2}$ " AVG.	3'-8" TO 56'-5"
	A20	1	#6 BNT.	AS SHOWN	7'-7"	--
①	A21	430	#5 BNT.	7 $\frac{3}{8}$ " C/C	35'-7" AVG.	32'-10" TO 38'-5"
①	A22	430	#5 STR.	7 $\frac{3}{8}$ " C/C	34'-5" AVG.	31'-8" TO 37'-3"
①	A23	4	#5 BNT.	7 $\frac{3}{8}$ " C/C	19'-9 $\frac{1}{2}$ " AVG.	7'-1" TO 32'-6"
①	A24	4	#5 STR.	7 $\frac{3}{8}$ " C/C	19'-2 $\frac{1}{2}$ " AVG.	6'-6" TO 31'-11"
①	A25	1	#6 BNT.	AS SHOWN	2'-8"	--
①	A26	766	#5 BNT.	7 $\frac{3}{8}$ " C/C	32'-10"	--
①	A27	766	#5 STR.	7 $\frac{3}{8}$ " C/C	31'-8"	--
	A28	3	#5 BNT.	AS SHOWN	18'-6" AVG.	11'-5" TO 25'-7"
	A29	3	#5 STR.	AS SHOWN	17'-11" AVG.	10'-10" TO 25'-0"
	A30	1	#6 BNT.	AS SHOWN	8'-0"	--
	AH1	29	#4 BNT.	AS SHOWN	5'-3"	--
	AH2	4	#4 BNT.	AS SHOWN	4'-0"	--
	AS1	33	#4 BNT.	12" C/C	5'-1"	--
	AT1	1	#4 BNT.	AS SHOWN	50'-1"	--
	AT2	3	#4 STR.	AS SHOWN	45'-11"	--
②	AT3	8	#4 BNT.	AS SHOWN	62'-9"	--
	AT4	4	#4 BNT.	AS SHOWN	78'-6"	--
	AT5	4	#4 BNT.	AS SHOWN	37'-5"	--
	AT6	16	#4 STR.	AS SHOWN	31'-8"	--
	AT7	4	#4 BNT.	AS SHOWN	31'-9"	--
	AT8	1	#4 STR.	AS SHOWN	27'-7"	--

BAR LIST CONTINUED

②	E1	62	#4 STR.	EQUAL SPA.	142'-7 $\frac{1}{2}$ " AVG.	136'-4" TO 148'-11"
②	E2	62	#5 STR.	EQUAL SPA.	143'-7 $\frac{1}{2}$ " AVG.	137'-4" TO 149'-11"
②	E3	78	#4 STR.	EQUAL SPA.	160'-3" AVG.	153'-7" TO 167'-3"
②	E4	78	#5 STR.	EQUAL SPA.	161'-3" AVG.	154'-7" TO 168'-3"
②	E5	39	#4 STR.	EQUAL SPA.	291'-5" AVG.	284'-1" TO 298'-9"
②	E6	39	#5 STR.	EQUAL SPA.	293'-5" AVG.	286'-1" TO 300'-9"
② ③	E7	38	#6 STR.	EQUAL SPA.	98'-3 $\frac{1}{2}$ " AVG.	96'-5" TO 100'-2"
② ③	E8	38	#4 STR.	EQUAL SPA.	95'-3 $\frac{1}{2}$ " AVG.	93'-5" TO 97'-2"
②	E9	33	#4 STR.	12" C/C	289'-11" AVG.	284'-6" TO 295'-4"
②	E10	33	#5 STR.	12" C/C	291'-11" AVG.	286'-6" TO 297'-4"
② ③	E11	32	#6 STR.	12" C/C	98'-1 $\frac{1}{2}$ " AVG.	96'-5" TO 99'-10"
② ③	E12	32	#6 STR.	12" C/C	95'-1 $\frac{1}{2}$ " AVG.	93'-5" TO 96'-10"
②	E13	33	#4 STR.	12" C/C	225'-7 $\frac{1}{2}$ " AVG.	220'-5" TO 230'-10"
②	E14	33	#5 STR.	12" C/C	227'-1 $\frac{1}{2}$ " AVG.	221'-115" TO 232'-4"
② ③	E15	32	#6 STR.	12" C/C	79'-10" AVG.	79'-9" TO 79'-11"
② ③	E16	32	#4 STR.	12" C/C	76'-10" AVG.	76'-9" TO 76'-11"
	EPH	362	#4 BNT.	AS SHOWN	3'-5"	--
	FS2	1984	#5 BNT.	SEE STD.	7'-4"	--
	L	152	#4 BNT.	SEE STD.	1'-3"	--
	U1	8	#5 BNT.	AS SHOWN	7'-1"	--

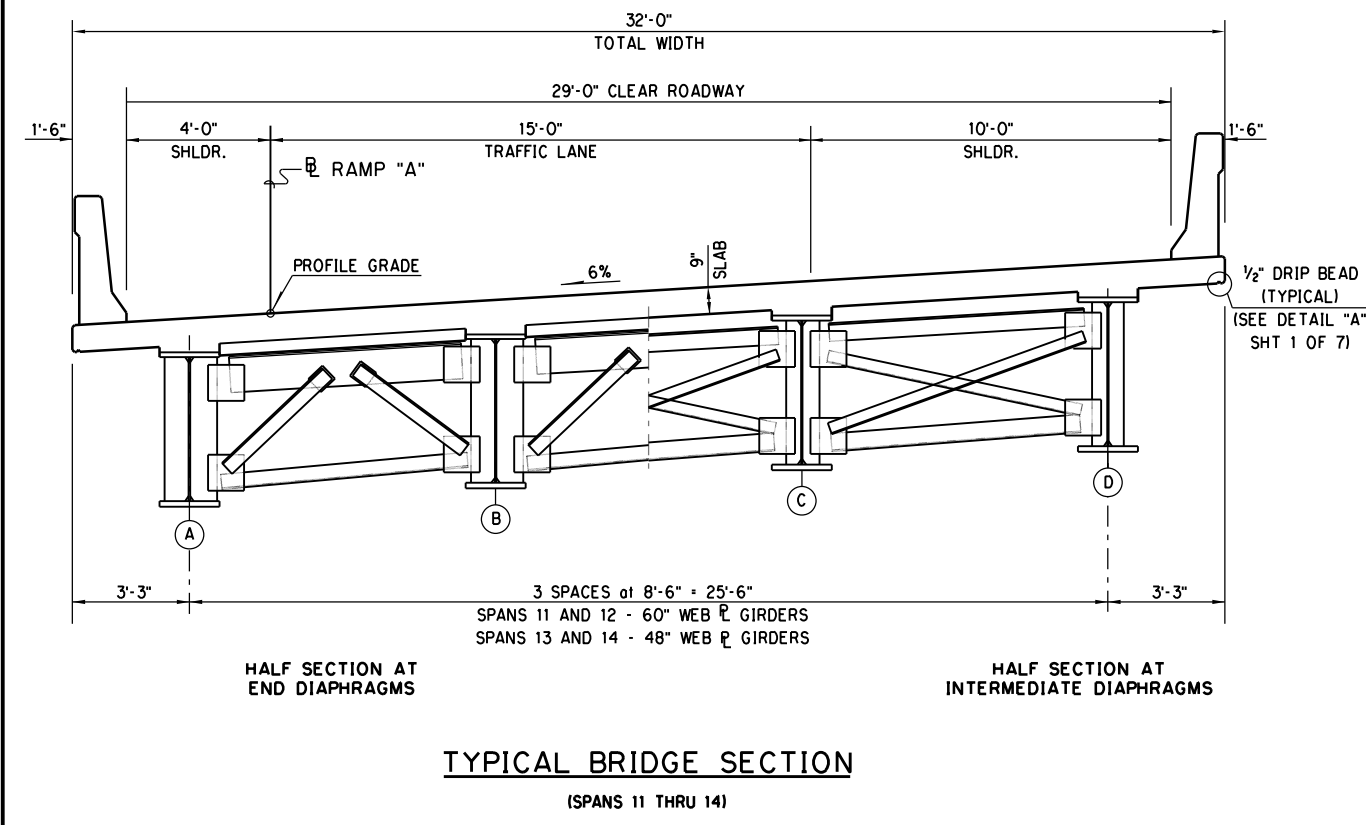

- ① BARS ARE ALIGNED RADIALY ALONG BASELINE OF RAMP "A", SPACING LISTED IS ALONG BASELINE, MAXIMUM END SPACING IS 8" C/C
- ② LENGTH SHOWN INCLUDES LAP: A4 = 1 at 2'-6" E1 = 2 at 2'-0" E11 = 1 at 3'-0"
 A5 = 1 at 2'-6" E2 = 2 at 2'-6" E12 = 1 at 2'-0"
 A11=1 at 2'-6" E3 = 2 at 2'-0" E13= 3 at 2'-0"
 A12=1 at 2'-6" E4 = 2 at 2'-6" E14= 3 at 2'-6"
 A13=1 at 2'-6" E5 = 4 at 2'-0" E15= 1 at 3'-0"
 A14=1 at 2'-6" E6 = 4 at 2'-6" E16= 1 at 2'-0"
 E7 = 1 at 3'-0"
 AT3 = 1 at 2'-0" E8 = 1 at 2'-0"
 AT4 = 1 at 2'-0" E9 = 4 at 2'-0"
 E10 = 4 at 2'-6"
- ③ LENGTH SHOWN INCLUDES EXTENSION: E7 = 2 at 2'-6"
 E8 = 2 at 1'-6"
 E11 = 2 at 2'-6"
 E12 = 2 at 1'-6"
 E15 = 2 at 2'-6"
 E16 = 2 at 1'-6"

3/1/2024 3:20:44 PM H:\PROJECTS\2789_Crossroads_Phase 4 Bridge Drawings\Phase 4 Bridge\Drawings\Bridges\Phase 4 Bridge A SUPER.dgn

DESIGN		PHASE 4	OKLAHOMA COUNTY
DRAWN		BRIDGE "A"	RAMP "A" AT I-35 & I-240 INTERCHANGE
CHECKED		SUPERSTRUCTURE DETAILS SPAN 9 THRU 14 SECTIONS (SHEET 2 OF 7)	
APPROVED			
SQUAD	POE	STATE JOB NO. 090321081 SHEET NO. B035	

*NOTE: CONCRETE PARAPET OMITTED FROM SLAB FOR CLARITY.
(SEE "PARAPET LAYOUT" AND STD. FSHP-42-2 FOR PARAPET DETAILS)

CURVE DATA RA-3, RJ-1
SEE ROADWAY SHEETS:
"GEOMETRIC COORDINATE POINT TABLES"
FOR CURVE DATA.

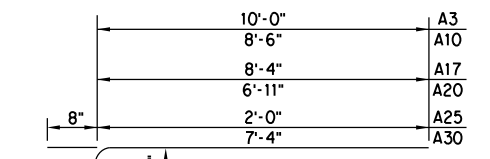
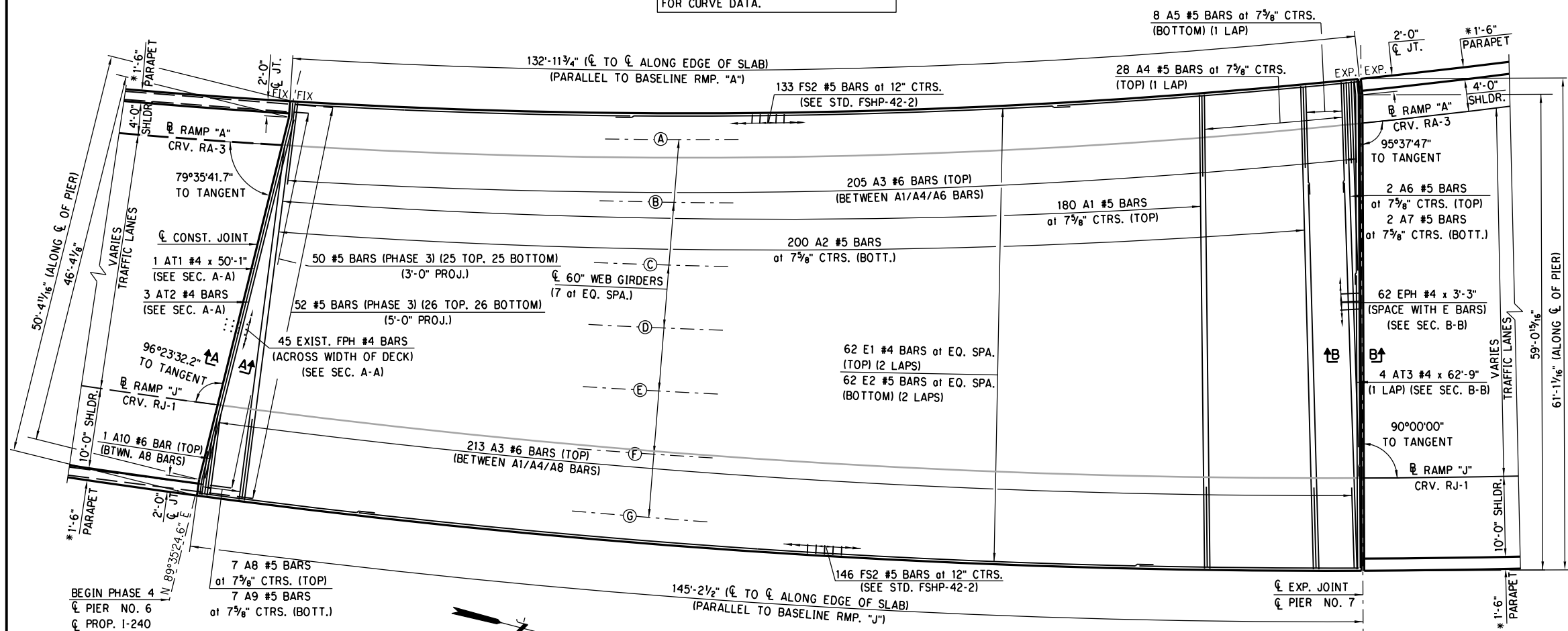

A3 #6 x 10'-8"
A10 #6 x 9'-2"
A17 #6 x 9'-0"
A20 #6 x 7'-7"
A25 #6 x 2'-8"
A30 #6 x 8'-0"

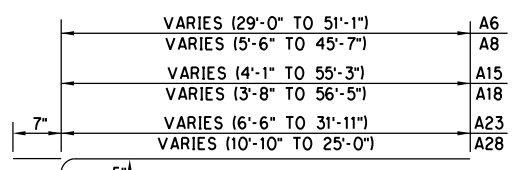

VARIES (29'-0" TO 51'-1") A6
VARIES (5'-6" TO 45'-7") A8
VARIES (4'-1" TO 55'-3") A15
VARIES (3'-8" TO 56'-5") A18
VARIES (6'-6" TO 31'-11") A23
VARIES (10'-10" TO 25'-0") A28

A6 #5 x 40'-7 1/2" AVG.
(29'-7" TO 51'-8")
A8 #5 x 26'-1 1/2" AVG.
(62'-7" TO 64'-2")
A15 #5 x 30'-3" AVG.
(4'-8" TO 55'-10")
A18 #5 x 30'-7 1/2" AVG.
(4'-3" TO 57'-0")
A23 #5 x 19'-9 1/2" AVG.
(7'-1" TO 32'-6")
A28 #5 x 18'-6" AVG.
(11'-5" TO 25'-7")

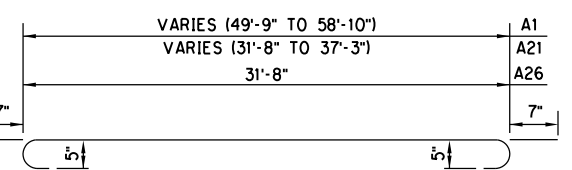

VARIES (49'-9" TO 58'-10") A1
VARIES (31'-8" TO 37'-3") A21
31'-8" A26

A1 #5 x 55'-5 1/2" AVG.
(50'-11" TO 60'-0")
A21 #5 x 37'-5" AVG.
(32'-10" TO 38'-5")
A26 #5 x 32'-10"

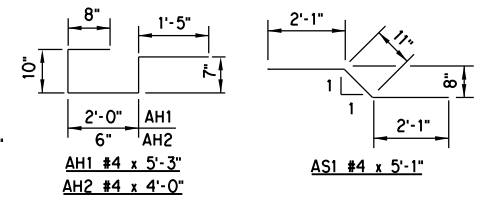
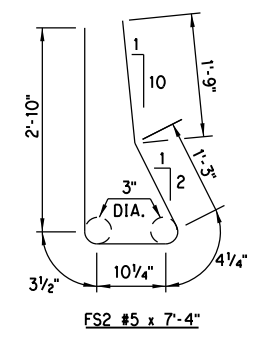

AH1 #4 x 5'-3"
AH2 #4 x 4'-0"
AS1 #4 x 5'-1"

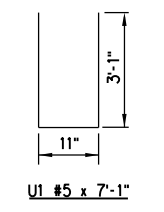

U1 #5 x 7'-1"

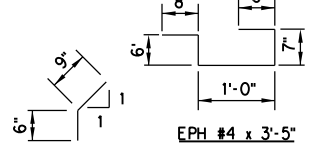

EPH #4 x 3'-5"
L #4 x 1'-3"

SLAB REINFORCING LAYOUT

SPAN 7

NOTE: SEE SECTION A-A THIS SHEET
AND SECTION B-B, SHEET 4 OF 7

NOTE: STAGGER ALL E1/E2 BAR LAPS

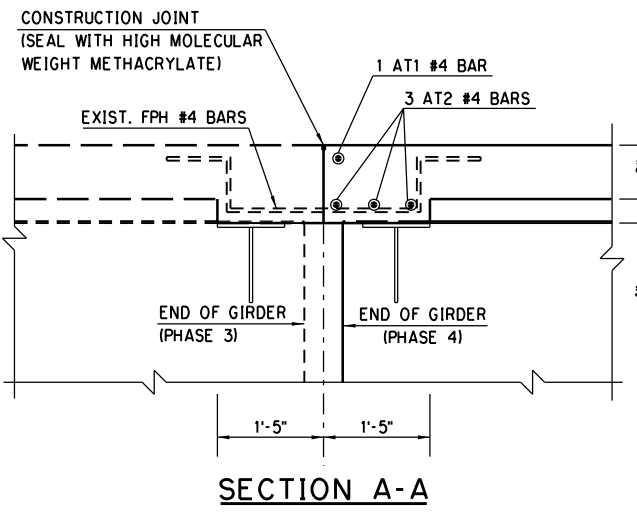

NOTE: SLAB REINFORCING OMITTED
IN SECTIONS FOR CLARITY.

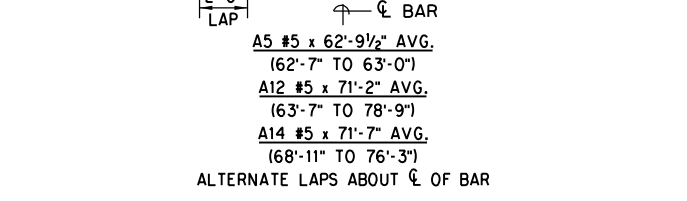
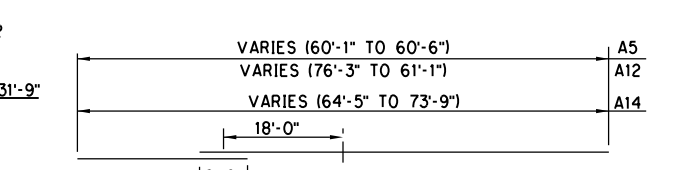
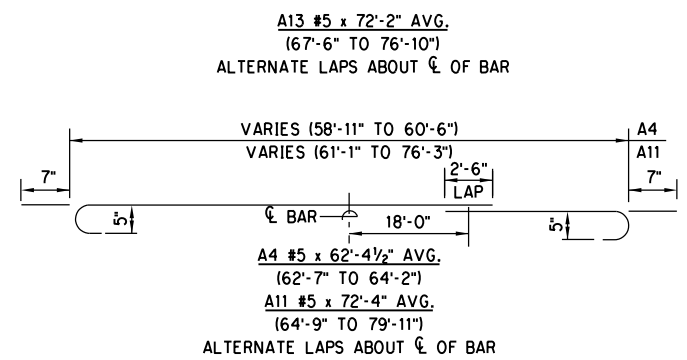
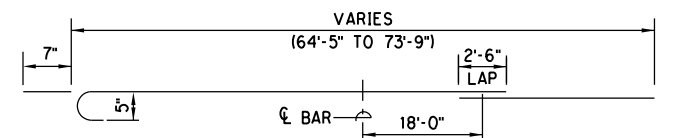
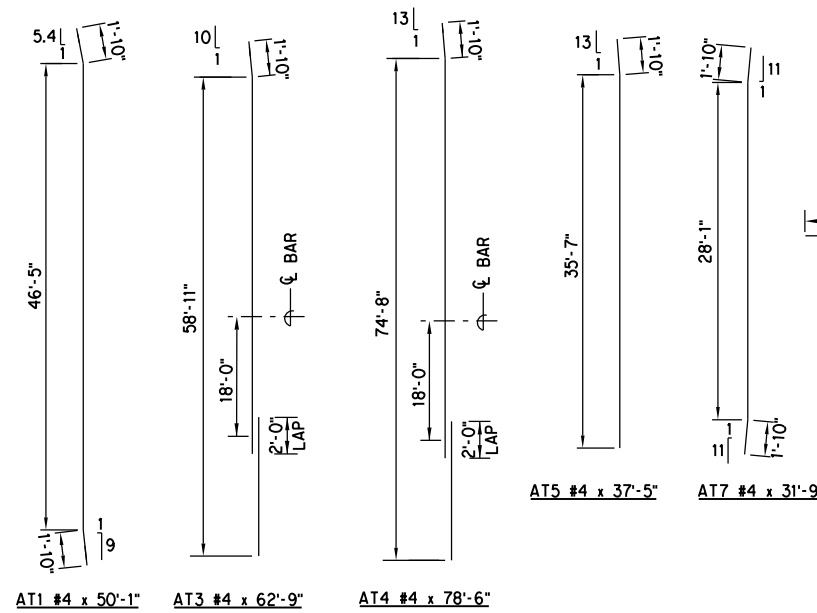

DESIGN		BRIDGE "A"	RAMP "A" AT I-35 & I-240 INTERCHANGE
DRAWN		SUPERSTRUCTURE DETAILS	
CHECKED		SPAN 7	
APPROVED		(SHEET 3 OF 7)	
SQUAD	POE	STATE JOB NO. 09032(08)	SHEET NO. B036

*NOTE: CONCRETE PARAPET OMITTED FROM SLAB FOR CLARITY.
(SEE "PARAPET LAYOUT" AND STD. FSHP-42-2 FOR PARAPET DETAILS)

CURVE DATA RA-3, RJ-1, RJ-2
SEE ROADWAY SHEETS:
"GEOMETRIC COORDINATE POINT TABLES"
FOR CURVE DATA.

7 A15 #5 BARS
at 7 7/8" CTRS. (TOP)
7 A16 #5 BARS
at 7 7/8" CTRS. (BOTT.)

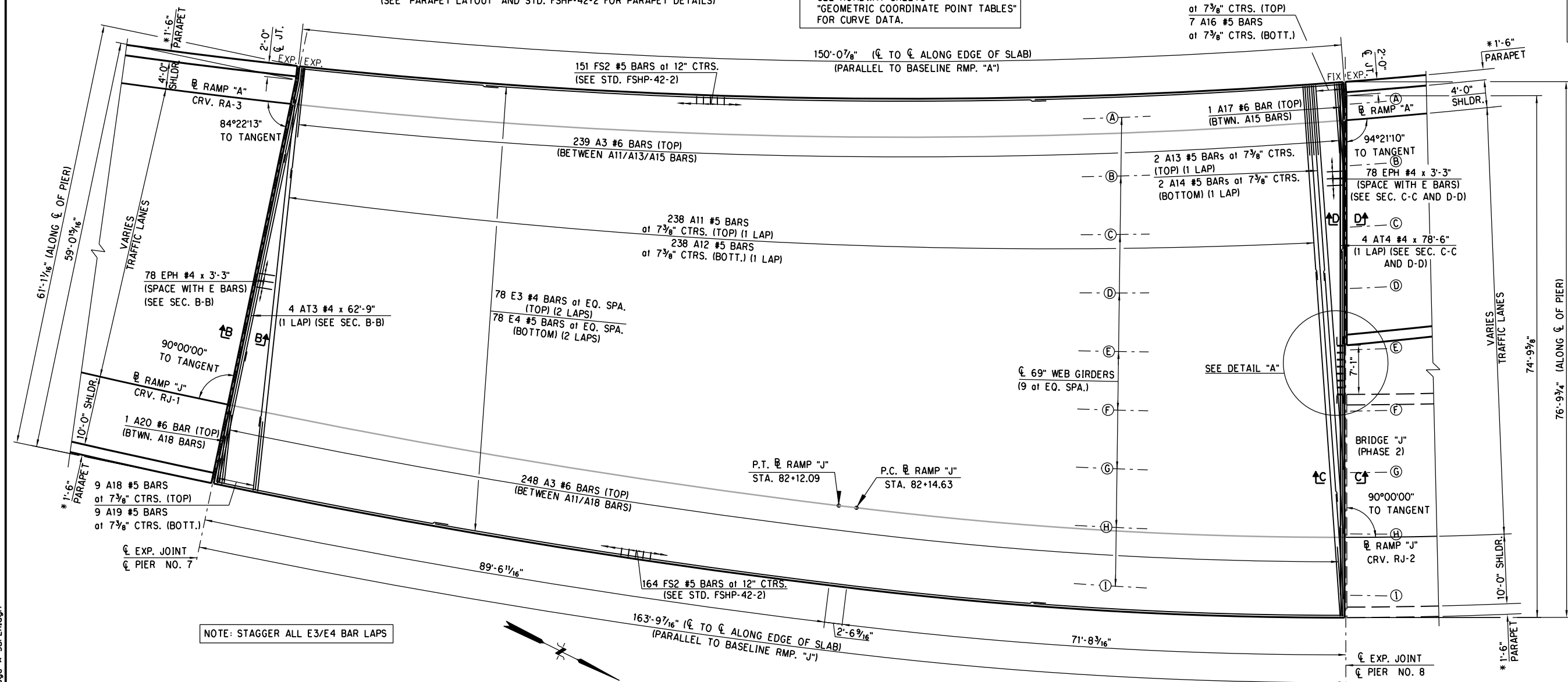

NOTE: STAGGER ALL E3/E4 BAR LAPS

SLAB REINFORCING LAYOUT
SPAN 8

NOTE: FOR SECTION D-D. SEE SHEET 5 OF 7

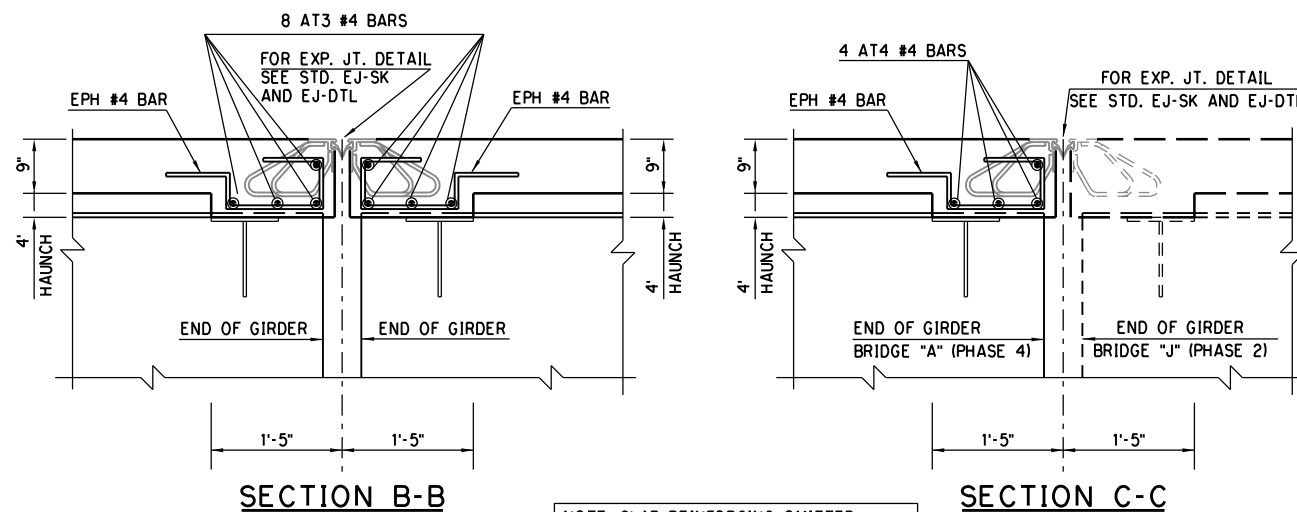

NOTE: SLAB REINFORCING OMITTED
IN SECTIONS FOR CLARITY.

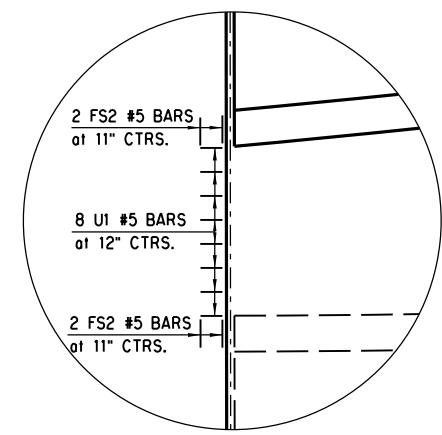

DETAIL "A"

SLAB REINFORCING FOR END BARRIER WALL
(WALL NOT SHOWN FOR CLARITY, FOR DETAILS ON
WALL, SEE "END BARRIER LAYOUT" SHEET.)

DESIGN		PHASE 4	OKLAHOMA COUNTY
DRAWN		BRIDGE "A"	RAMP "A" AT I-35 & I-240 INTERCHANGE
CHECKED		SUPERSTRUCTURE DETAILS	
APPROVED			
SQUAD	POE	SPAN 8 (SHEET 4 OF 7)	
		STATE JOB NO. 09032(08) SHEET NO. B037	

*NOTE: CONCRETE PARAPET OMITTED FROM SLAB FOR CLARITY.
(SEE "PARAPET LAYOUT" AND STD. FSHP-42-2 FOR PARAPET DETAILS)

CURVE DATA RA-3
SEE ROADWAY SHEETS:
"GEOMETRIC COORDINATE POINT TABLES"
FOR CURVE DATA.

**NOTE: TRANSVERSE BARS (A BARS) SHOULD MAINTAIN 2" CLEARANCE FROM SLAB JOINTS.
SLAB JOINT OR BAR LOCATION MAY BE MINIMALLY SHIFTED FOR REQUIRED CLEARANCE.

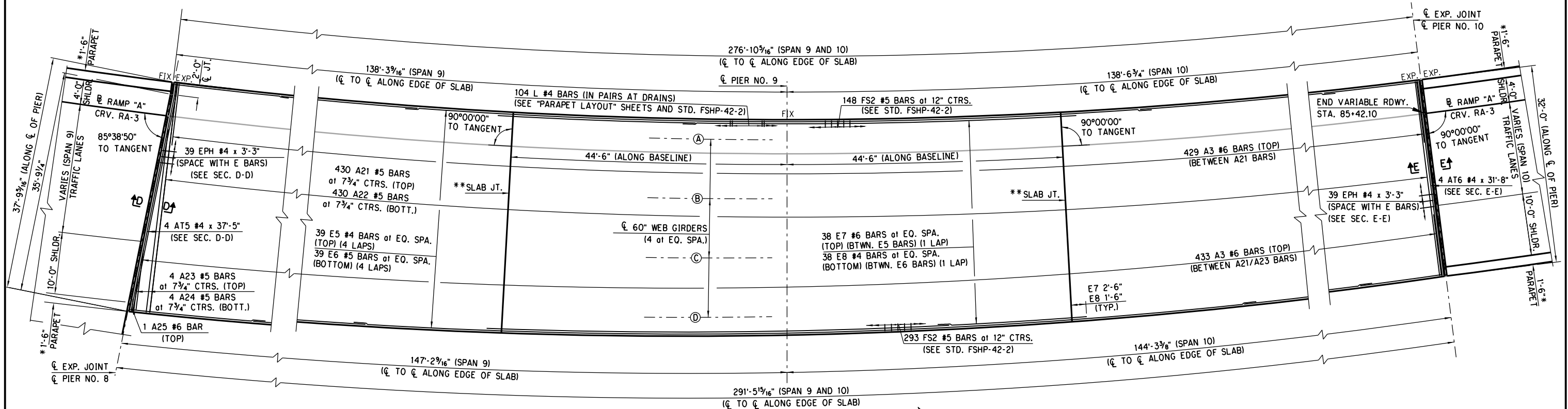

NOTE: STAGGER ALL E5/E6 AND E7/E8 BAR LAPS.
NO LAPS WITHIN 10 FEET OF SLAB JOINTS.

SLAB REINFORCING LAYOUT
SPANS 9 AND 10

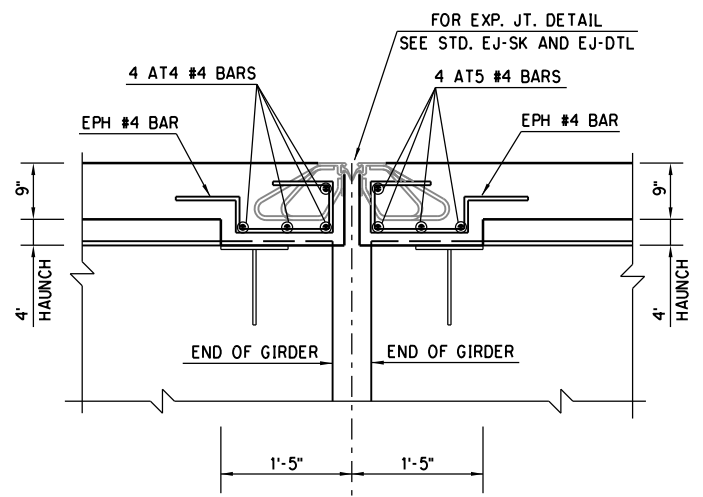

SECTION D-D
NOTE: SLAB REINFORCING OMITTED
IN SECTIONS FOR CLARITY.

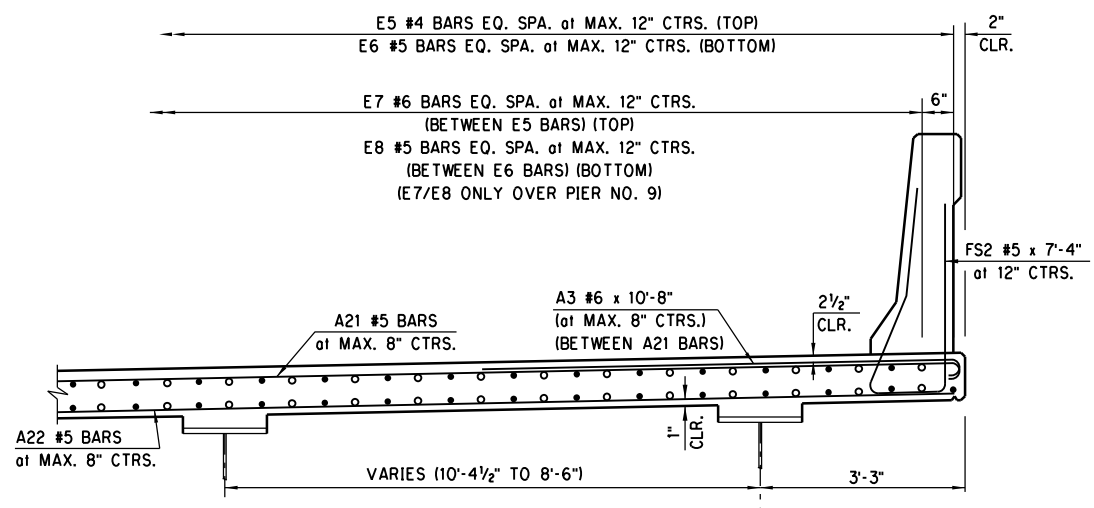

TYPICAL BRIDGE REINFORCING SECTION
(SPANS 9 AND 10)

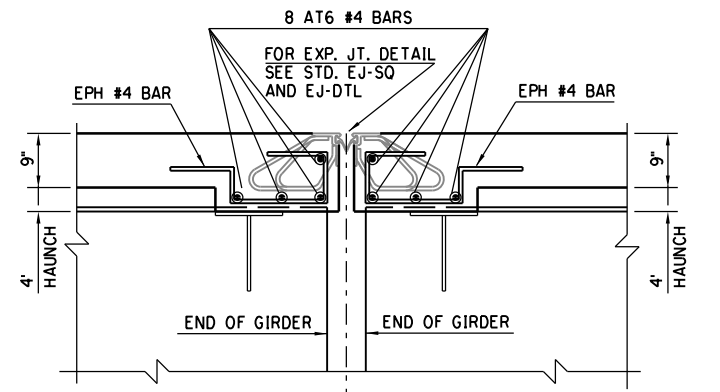

SECTION E-E

DESIGN		PHASE 4	OKLAHOMA COUNTY
DRAWN		BRIDGE "A"	RAMP "A" AT I-35 & I-240 INTERCHANGE
CHECKED		SUPERSTRUCTURE DETAILS	
APPROVED		SPANS 9 AND 10	
SQUAD	POE	(SHEET 5 OF 7)	
		STATE JOB NO. 09032(08)	SHEET NO. B038

3/1/2024 3:20:50 PM H:\PROJECTS\2789_CrossRoads_Phase 4\Bridges\Drawings\Ph4 Bridges\Bridges\A0903208 P4 Bridge A SUPER.dgn

CURVE DATA RA-3
SEE ROADWAY SHEETS:
"GEOMETRIC COORDINATE POINT TABLES"
FOR CURVE DATA.

*NOTE: CONCRETE PARAPET OMITTED FROM SLAB FOR CLARITY.
(SEE "PARAPET LAYOUT" AND STD. FSHP-42-2 FOR PARAPET DETAILS)

**NOTE: TRANSVERSE BARS (A BARS) SHOULD MAINTAIN 2" CLEARANCE FROM SLAB JOINTS.
SLAB JOINT OR BAR LOCATION MAY BE MINIMALLY SHIFTED FOR REQUIRED CLEARANCE.

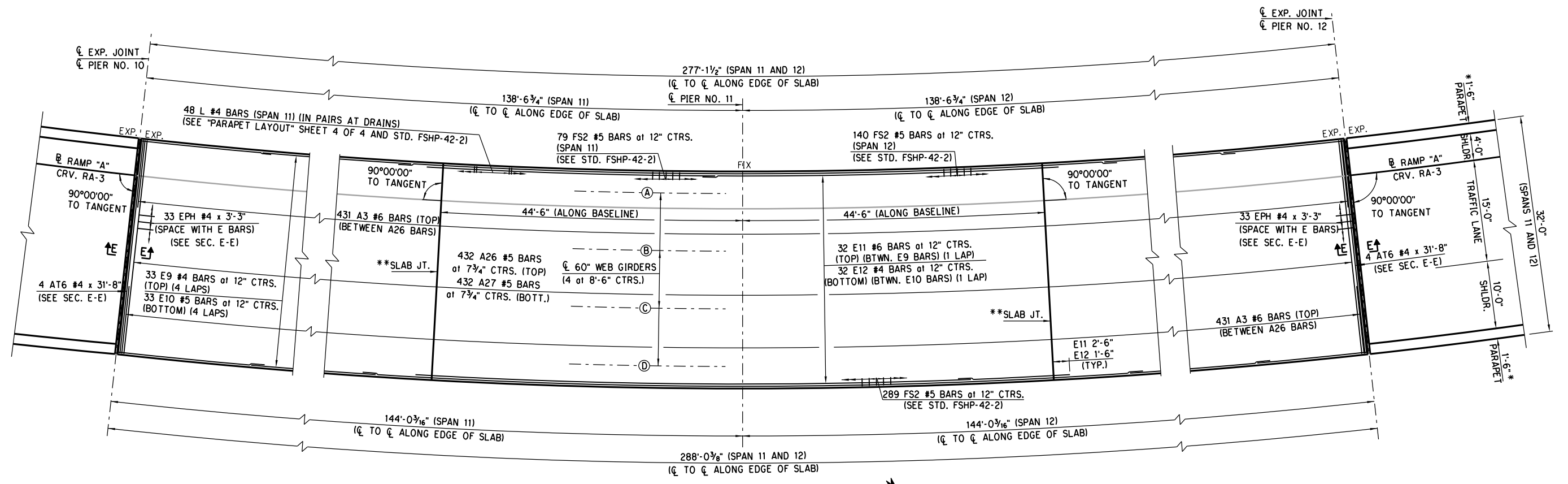

NOTE: STAGGER ALL E9/E10 AND
E11/E12 BAR LAPS.
NO LAPS WITHIN 10 FEET
OF SLAB JOINTS.

SLAB REINFORCING LAYOUT
SPANS 11 AND 12
NOTE: FOR SECTION E-E SEE SHEET 5 OF 7

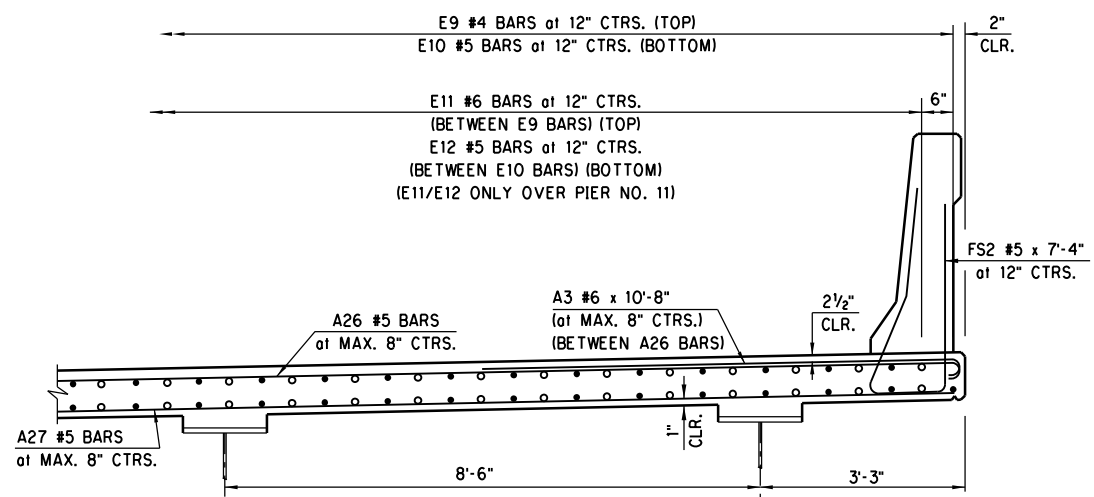

TYPICAL BRIDGE REINFORCING SECTION
(SPANS 11 AND 12)

DESIGN		PHASE 4	OKLAHOMA COUNTY
DRAWN		BRIDGE "A"	RAMP "A" AT I-35 & I-240 INTERCHANGE
CHECKED		SUPERSTRUCTURE DETAILS SPANS 11 AND 12 (SHEET 6 OF 7)	
APPROVED			
SQUAD	POE	STATE JOB NO. 09032(08)	SHEET NO. B039

3/1/2024 3:20:51 PM H:\PROJECTS\2789_CrossRoads_Phase 4\Bridges\Drawings\Ph4 Bridges\Bridges A\0903208 P4 Bridge A SUPER.dgn

CURVE DATA RA-3
SEE ROADWAY SHEETS:
"GEOMETRIC COORDINATE POINT TABLES"
FOR CURVE DATA.

*NOTE: CONCRETE PARAPET OMITTED FROM SLAB FOR CLARITY.
(SEE "PARAPET LAYOUT" AND STD. FSHP-42-2 FOR PARAPET DETAILS)

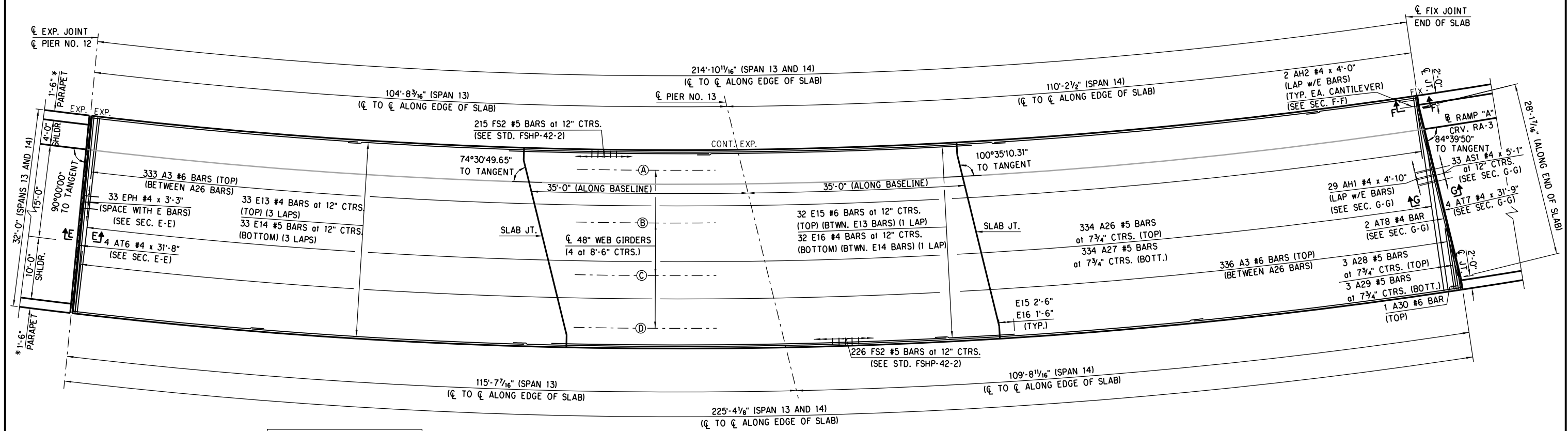

NOTE: STAGGER ALL E13/E14 AND E15/E16 BAR LAPS. NO LAPS WITHIN 10 FEET OF SLAB JOINTS.

SLAB REINFORCING LAYOUT

SPANS 13 AND 14
NOTE: FOR SECTION E-E SEE SHEET 5 OF 7

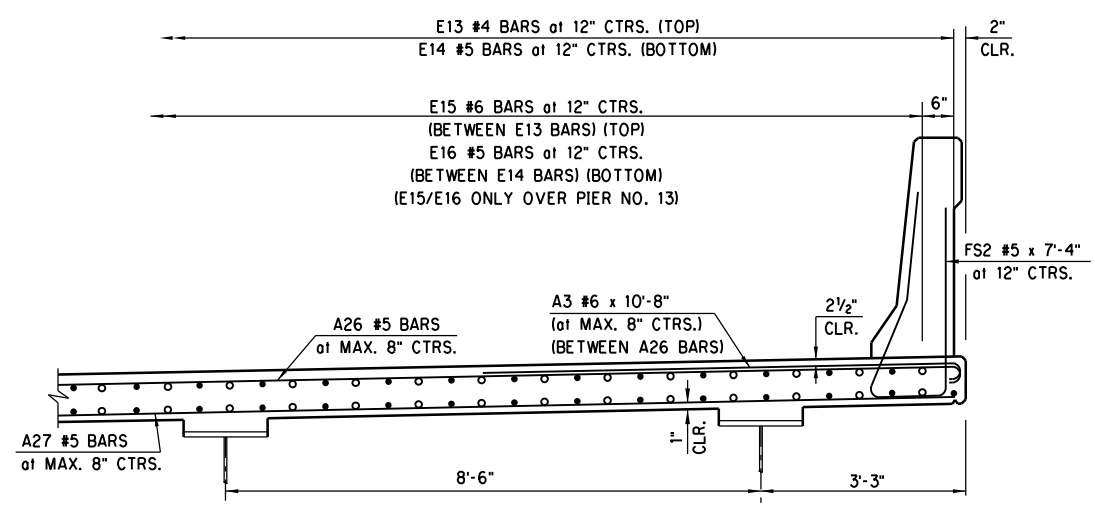

TYPICAL BRIDGE REINFORCING SECTION
(SPANS 13 AND 14)

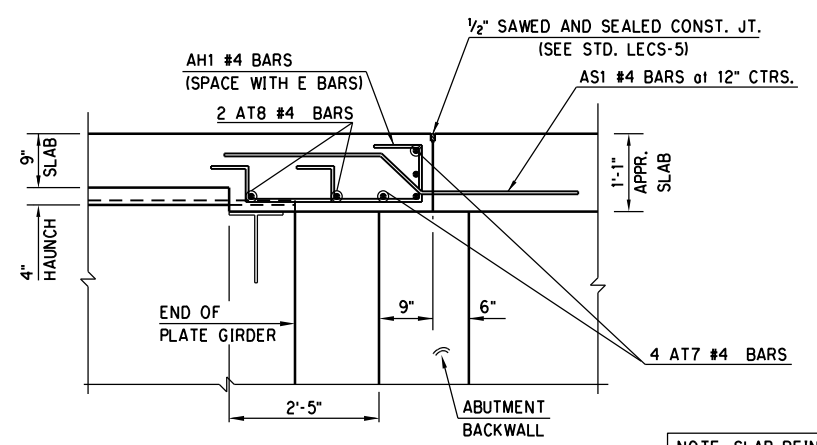

SECTION G-G

NOTE: SLAB REINFORCING OMITTED IN SECTIONS FOR CLARITY.

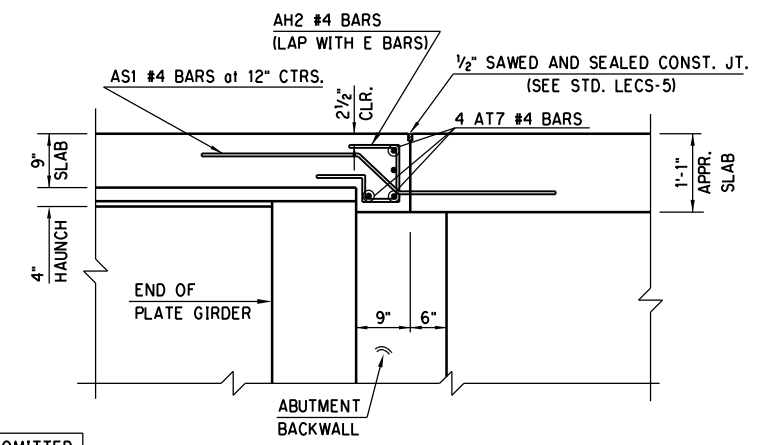

SECTION F-F
(TYPICAL AT CANTILEVER)

DESIGN		PHASE 4	OKLAHOMA COUNTY
DRAWN		BRIDGE "A"	RAMP "A" AT I-35 & I-240 INTERCHANGE
CHECKED		SUPERSTRUCTURE DETAILS	
APPROVED			
SQUAD	POE	SPANS 13 AND 14 (SHEET 7 OF 7)	
		STATE JOB NO. 09032(08)	SHEET NO. B040

3/1/2024 3:20:52 PM H:\PROJECTS\2789_CrossRoads_Phase 4\Bridges\Drawings\Ph4 Bridges\Bridges A\0903208 P4 Bridge A SUPER.dgn

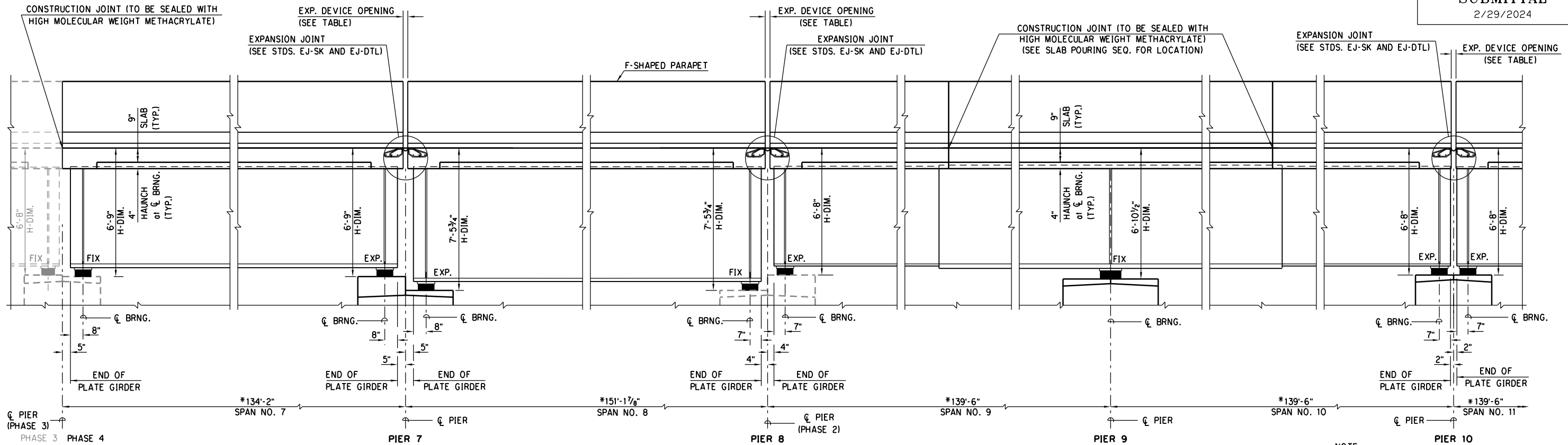

LONGITUDINAL SECTION

* SPAN LENGTHS MEASURED ALONG RAMP "A"

NOTE:
H-DIMENSION SHOWN IS MEASURED FROM TOP OF SLAB TO BOTTOM OF BEARING ASSEMBLY AT CL BEARING.

TABLE OF EXPANSION DEVICE SETTINGS

PIER NO.	TEMPERATURE	34°	39°	44°	49°	55°	60°	65°	71°	76°	81°	86°	92°	97°	102°
	PIER NO. 7	OPENING	2 5/8"	2 1/2"	2 3/8"	2 1/4"	2 1/8"	2"	1 7/8"	1 3/4"	1 5/8"	1 1/2"	1 3/8"	1 1/4"	1 1/8"
PIER NO. 8	TEMPERATURE	--	--	28°	39°	49°	60°	71°	81°	92°	103°	--	--	--	--
	OPENING	--	--	2 3/8"	2 1/4"	2 1/8"	2"	1 7/8"	1 3/4"	1 5/8"	1 1/2"	--	--	--	--
PIER NO. 10	TEMPERATURE	--	38°	43°	49°	54°	60°	66°	71°	77°	82°	88°	94°	99°	105°
	OPENING	--	2 1/2"	2 3/8"	2 1/4"	2 1/8"	2"	1 7/8"	1 3/4"	1 5/8"	1 1/2"	1 3/8"	1 1/4"	1 1/8"	1"

SLAB POURING SEQUENCE:

THE POURING SEQUENCE SHALL BE IN THE NUMERICAL SEQUENCE INDICATED. ALL POURS WITH THE SAME NUMBER MAY BE Poured EITHER SEPARATELY OR SIMULTANEOUSLY, BUT ALL POURS WITH THE SAME NUMBER SHALL BE COMPLETED BEFORE BEGINNING WITH THE NEXT POUR NUMBER. THERE SHALL BE A LAPSE OF AT LEAST 24 HOURS BETWEEN POURS OR WHEN THE PREVIOUS POUR REACHES A STRENGTH OF 3000 PSI.

IN THE EVENT OF AN EMERGENCY, POURING OF DECK SLAB MAY BE HALTED WITH A CONSTRUCTION JOINT MADE PERPENDICULAR TO THE DIRECTION OF TRAFFIC AS DIRECTED BY THE ENGINEER. PRIMARY LONGITUDINAL REINFORCING SHALL BE CONTINUOUS THRU ALL CONSTRUCTION JOINTS. ADDITIONAL LONGITUDINAL REINFORCING WITHIN CLOSURE POURS SHALL BE CONTINUOUS THROUGH EMERGENCY CONSTRUCTION JOINTS. UNTIL THE SLAB IS IN PLACE ON BOTH SIDES OF THE CONSTRUCTION JOINT AND AT LEAST 48 HOURS HAS ELAPSED SINCE CONCRETE PLACEMENT, NO HEAVY EQUIPMENT WILL BE PERMITTED ON THE FINISHED DECK SLAB WITHIN 6 FEET OF ANY CONSTRUCTION JOINT.

ALL CONSTRUCTION JOINTS WITHIN THE DECK SLAB SHALL BE SEALED USING HIGH MOLECULAR WEIGHT METHACRYLATE IN ACCORDANCE WITH SECTION 523 OF THE STANDARD SPECIFICATIONS. ALL COST OF THE HIGH MOLECULAR WEIGHT METHACRYLATE SEALER SHALL BE INCLUDED IN THE CONTRACT UNIT PRICE OF "SEALER RESIN". ALL COST FOR EQUIPMENT AND LABOR FOR THE INSTALLATION OF THE HIGH MOLECULAR WEIGHT METHACRYLATE SEALER SHALL BE INCLUDED IN THE CONTRACT UNIT PRICE OF "SEALER CRACK PREPARATION".

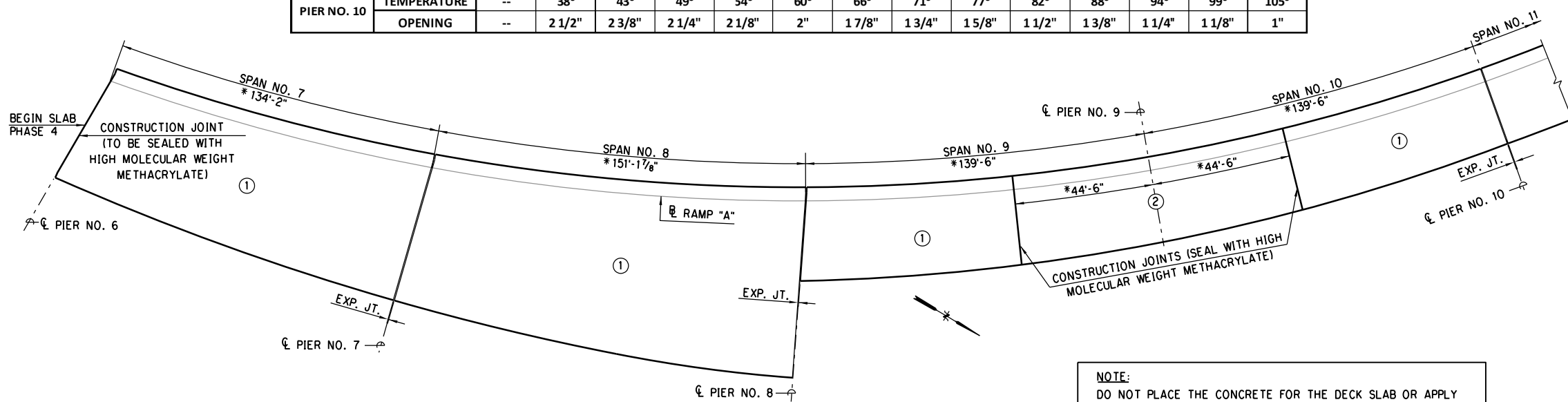

* LENGTHS MEASURED ALONG RAMP "A"

SLAB POURING SEQUENCE

SPANS NO. 7 THRU 10
(SEE SHEET 2 OF 2 FOR SPANS 11 THRU 14)

NOTE:
DO NOT PLACE THE CONCRETE FOR THE DECK SLAB OR APPLY OTHER MASSIVE LOADS TO THE BEAMS OR DIAPHRAGMS UNTIL THE CONCRETE IN THE DIAPHRAGMS HAS BEEN IN PLACE A MINIMUM OF 10 DAYS OR AT THE DISCRETION OF THE ENGINEER. THE ENGINEER MAY APPROVE SHORTENED TIME IF BOTH THE BEAM AND DIAPHRAGM CONCRETE HAS ATTAINED 80% OF THE SPECIFIED COMPRESSIVE STRENGTH.

DESIGN		PHASE 4	OKLAHOMA COUNTY
DRAWN		BRIDGE "A"	RAMP "A" AT I-35 & I-240 INTERCHANGE
CHECKED		LONGITUDINAL SECTION AND SLAB POURING SEQUENCE (SHEET 1 OF 2)	
APPROVED			
SQUAD	POE	STATE JOB NO. 09032108 SHEET NO. B041	

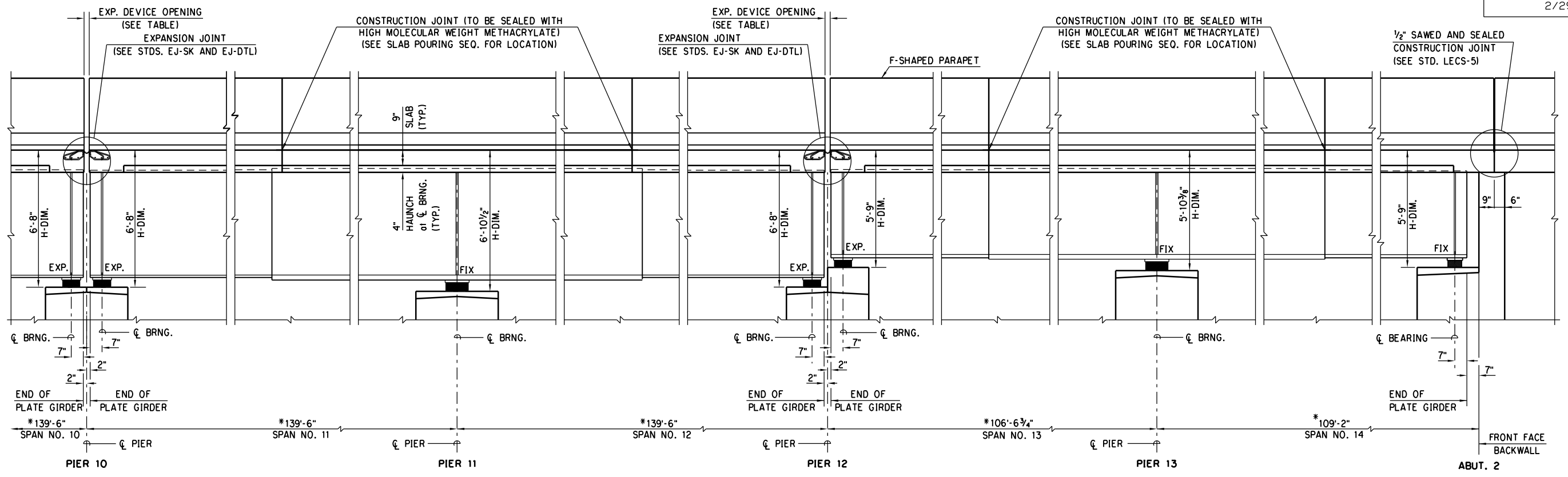

LONGITUDINAL SECTION
* SPAN LENGTHS MEASURED ALONG RAMP "A"

NOTE:
H-DIMENSION SHOWN IS MEASURED FROM TOP OF SLAB TO BOTTOM OF BEARING ASSEMBLY AT CL BEARING.

TABLE OF EXPANSION DEVICE SETTINGS																
PIER NO. 10	TEMPERATURE	--	38°	43°	49°	54°	60°	66°	71°	77°	82°	88°	94°	99°	105°	--
	OPENING	--	2 1/2"	2 3/8"	2 1/4"	2 1/8"	2"	1 7/8"	1 3/4"	1 5/8"	1 1/2"	1 3/8"	1 1/4"	1 1/8"	1"	--
PIER NO. 12	TEMPERATURE	38°	42°	47°	51°	56°	60°	64°	69°	73°	78°	82°	86°	91°	95°	99°
	OPENING	2 5/8"	2 1/2"	2 3/8"	2 1/4"	2 1/8"	2"	1 7/8"	1 3/4"	1 5/8"	1 1/2"	1 3/8"	1 1/4"	1 1/8"	1"	0 7/8"

SLAB POURING SEQUENCE:

THE POURING SEQUENCE SHALL BE IN THE NUMERICAL SEQUENCE INDICATED. ALL POURS WITH THE SAME NUMBER MAY BE POURED EITHER SEPARATELY OR SIMULTANEOUSLY, BUT ALL POURS WITH THE SAME NUMBER SHALL BE COMPLETED BEFORE BEGINNING WITH THE NEXT POUR NUMBER. THERE SHALL BE A LAPSE OF AT LEAST 24 HOURS BETWEEN POURS OR WHEN THE PREVIOUS POUR REACHES A STRENGTH OF 3000 PSI.

IN THE EVENT OF AN EMERGENCY, POURING OF DECK SLAB MAY BE HALTED WITH A CONSTRUCTION JOINT MADE PERPENDICULAR TO THE DIRECTION OF TRAFFIC AS DIRECTED BY THE ENGINEER. PRIMARY LONGITUDINAL REINFORCING SHALL BE CONTINUOUS THRU ALL CONSTRUCTION JOINTS. ADDITIONAL LONGITUDINAL REINFORCING WITHIN CLOSURE POURS SHALL BE CONTINUOUS THROUGH EMERGENCY CONSTRUCTION JOINTS. UNTIL THE SLAB IS IN PLACE ON BOTH SIDES OF THE CONSTRUCTION JOINT AND AT LEAST 48 HOURS HAS ELAPSED SINCE CONCRETE PLACEMENT, NO HEAVY EQUIPMENT WILL BE PERMITTED ON THE FINISHED DECK SLAB WITHIN 6 FEET OF ANY CONSTRUCTION JOINT.

ALL CONSTRUCTION JOINTS WITHIN THE DECK SLAB SHALL BE SEALED USING HIGH MOLECULAR WEIGHT METHACRYLATE IN ACCORDANCE WITH SECTION 523 OF THE STANDARD SPECIFICATIONS. ALL COST OF THE HIGH MOLECULAR WEIGHT METHACRYLATE SEALER SHALL BE INCLUDED IN THE CONTRACT UNIT PRICE OF "SEALER RESIN". ALL COST FOR EQUIPMENT AND LABOR FOR THE INSTALLATION OF THE HIGH MOLECULAR WEIGHT METHACRYLATE SEALER SHALL BE INCLUDED IN THE CONTRACT UNIT PRICE OF "SEALER CRACK PREPARATION".

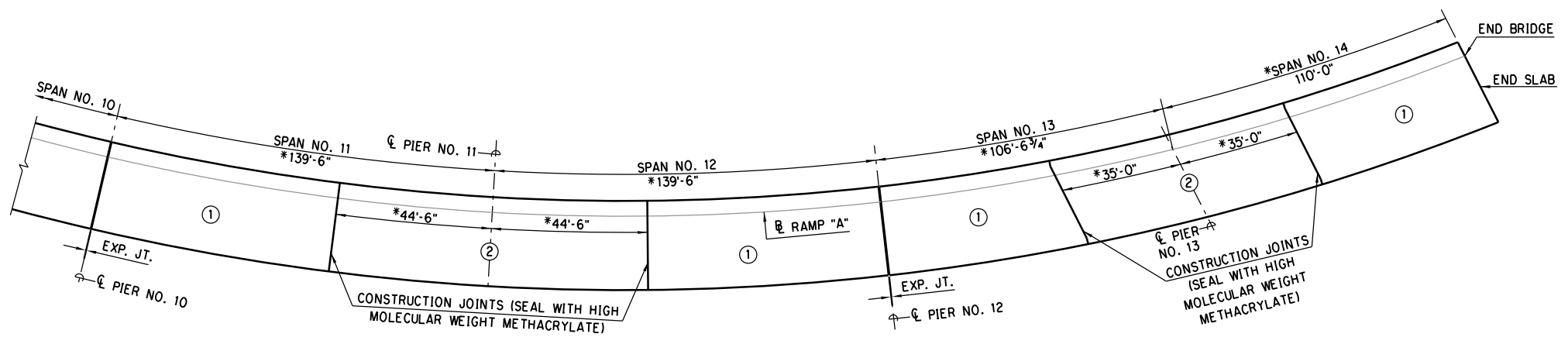

* LENGTHS MEASURED ALONG RAMP "A"
SLAB POURING SEQUENCE
SPANS NO. 11 THRU 14
(SEE SHEET 1 OF 2 FOR SPANS 7 THRU 10)

NOTE:
DO NOT PLACE THE CONCRETE FOR THE DECK SLAB OR APPLY OTHER MASSIVE LOADS TO THE BEAMS OR DIAPHRAGMS UNTIL THE CONCRETE IN THE DIAPHRAGMS HAS BEEN IN PLACE A MINIMUM OF 10 DAYS OR AT THE DISCRETION OF THE ENGINEER. THE ENGINEER MAY APPROVE SHORTENED TIME IF BOTH THE BEAM AND DIAPHRAGM CONCRETE HAS ATTAINED 80% OF THE SPECIFIED COMPRESSIVE STRENGTH.

DESIGN		PHASE 4		OKLAHOMA COUNTY	
DRAWN		BRIDGE "A"		RAMP "A" AT I-35 & I-240 INTERCHANGE	
CHECKED		LONGITUDINAL SECTION AND SLAB POURING SEQUENCE (SHEET 2 OF 2)			
APPROVED					
SQUAD		POE		STATE JOB NO. 090321081 SHEET NO. B042	

3/1/2024 3:20:56 PM H:\PROJECTS\2789_CrossRoads_Phase 4\Bridges\Drawings\Ph4 Bridges\Bridges\A\0903208 P4 Bridge A Longi.dgn

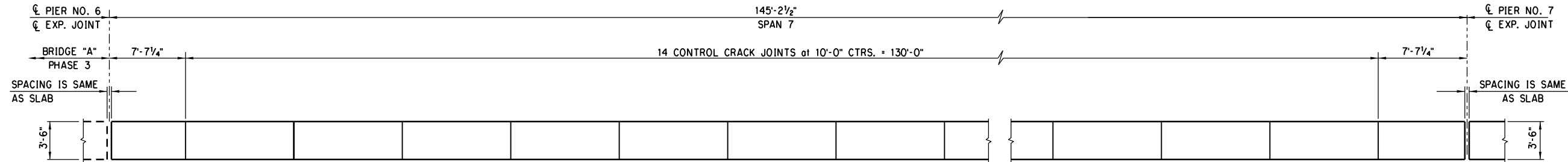

**NORTHEAST PARAPET JOINT SPACING
SPAN NO. 7**

(DIMENSIONS SHOWN ARE ϕ PIER to ϕ PIER ALONG OUTSIDE EDGE OF SLAB)

* PIER NO. 8 BRIDGE "A" = PIER NO. 1 BRIDGE "J"

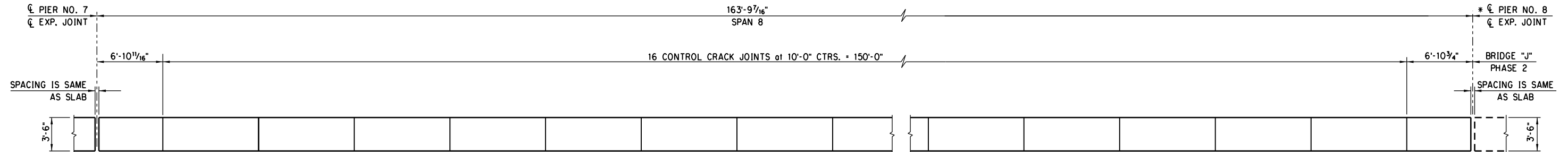

**NORTHEAST PARAPET JOINT SPACING
SPAN NO. 8**

(DIMENSIONS SHOWN ARE ϕ PIER to ϕ PIER ALONG OUTSIDE EDGE OF SLAB)

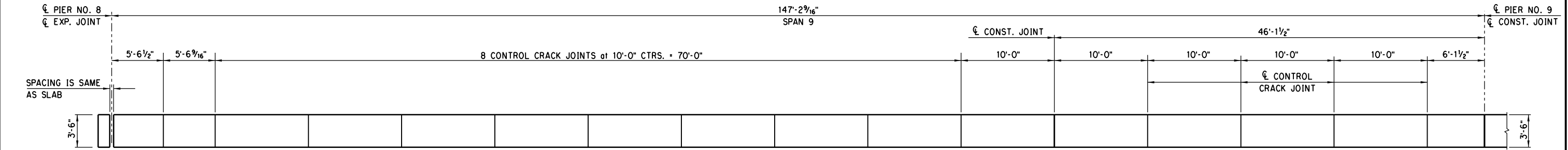

**NORTHEAST PARAPET JOINT SPACING
SPAN NO. 9**

(DIMENSIONS SHOWN ARE ϕ PIER to ϕ PIER ALONG OUTSIDE EDGE OF SLAB)

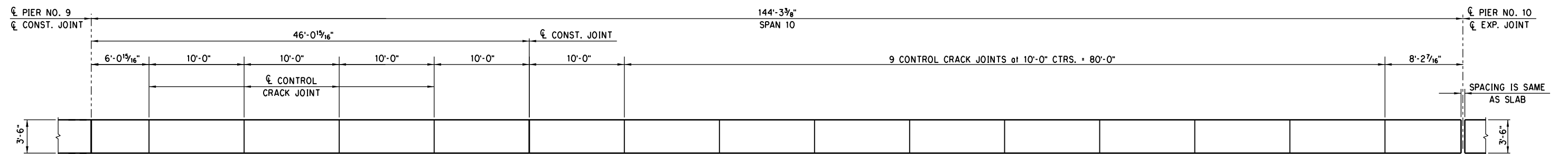

**EAST PARAPET JOINT SPACING
SPAN NO. 10**

(DIMENSIONS SHOWN ARE ϕ PIER to ϕ PIER ALONG OUTSIDE EDGE OF SLAB)

NOTE: FOR ADDITIONAL DETAILS,
SEE STD. FSHP-42-2.

PHASE 4 OKLAHOMA COUNTY

DESIGN		BRIDGE "A" RAMP "A" AT I-35 & I-240 INTERCHANGE PARAPET LAYOUT (SHEET 1 OF 4) STATE JOB NO. 09032(08) SHEET NO. B043
DRAWN		
CHECKED		
APPROVED		
SQUAD	POE	

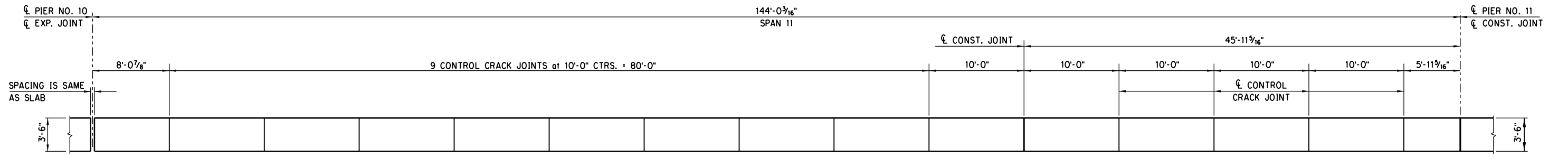

NORTHEAST PARAPET JOINT SPACING
SPAN NO. 11

(DIMENSIONS SHOWN ARE ϕ PIER TO ϕ PIER ALONG OUTSIDE EDGE OF SLAB)

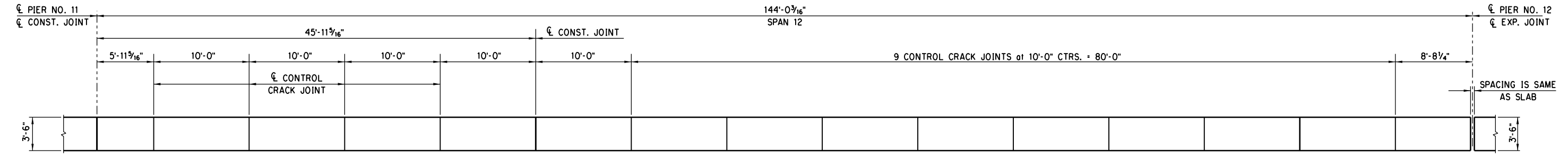

NORTHEAST PARAPET JOINT SPACING
SPAN NO. 12

(DIMENSIONS SHOWN ARE ϕ PIER TO ϕ PIER ALONG OUTSIDE EDGE OF SLAB)

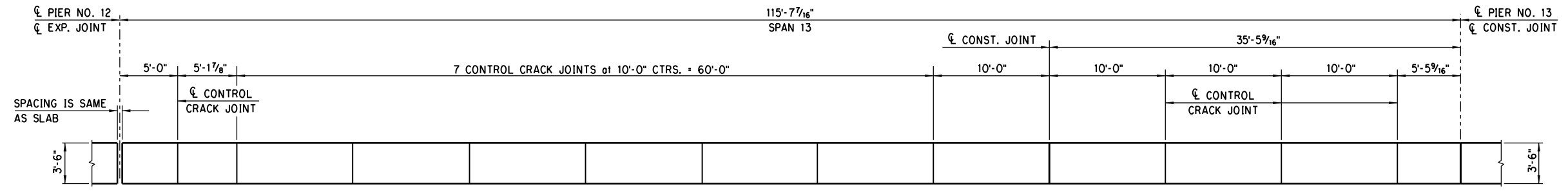

NORTHEAST PARAPET JOINT SPACING
SPAN NO. 13

(DIMENSIONS SHOWN ARE ϕ PIER TO ϕ PIER ALONG OUTSIDE EDGE OF SLAB)

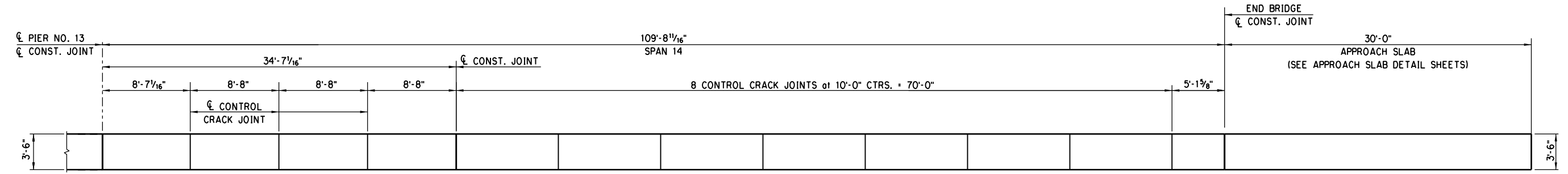

NORTHEAST PARAPET JOINT SPACING
SPAN NO. 14

(DIMENSIONS SHOWN ARE ϕ PIER TO ϕ PIER ALONG OUTSIDE EDGE OF SLAB)

NOTE: FOR ADDITIONAL DETAILS,
SEE STD. FSHP-42-2.

PHASE 4 OKLAHOMA COUNTY
BRIDGE "A" RAMP "A" AT I-35 & I-240 INTERCHANGE

DESIGN	
DRAWN	
CHECKED	
APPROVED	
SQUAD	POE

PARAPET LAYOUT
(SHEET 2 OF 4)

STATE JOB NO. 09032(08) SHEET NO. B044

3/1/2024 3:20:59 PM H:\PROJECTS\2789_CrossRoads_Phase 4\Bridges\Drawings\Ph4 Bridges\Bridges A Parapet Layout.dgn

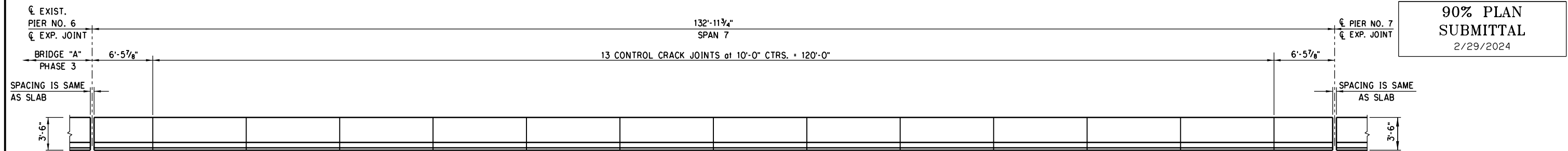

SOUTHWEST PARAPET JOINT SPACING
SPAN NO. 7
(DIMENSIONS SHOWN ARE ϕ PIER TO ϕ PIER ALONG OUTSIDE EDGE OF SLAB)

* PIER NO. 8 BRIDGE "A" = PIER NO. 1 BRIDGE "J"

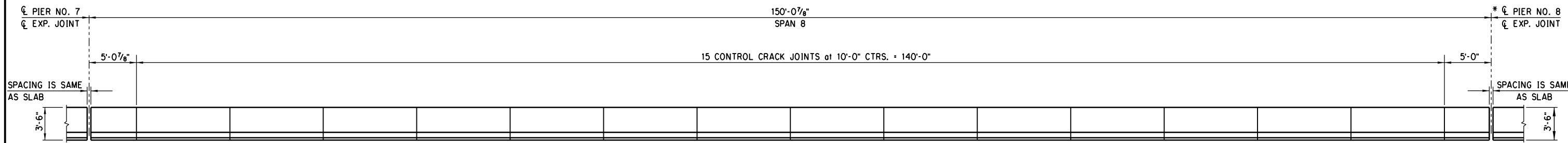

SOUTHWEST PARAPET JOINT SPACING
SPAN NO. 8
(DIMENSIONS SHOWN ARE ϕ PIER TO ϕ PIER ALONG OUTSIDE EDGE OF SLAB)

* PIER NO. 8 BRIDGE "A" = PIER NO. 1 BRIDGE "J"

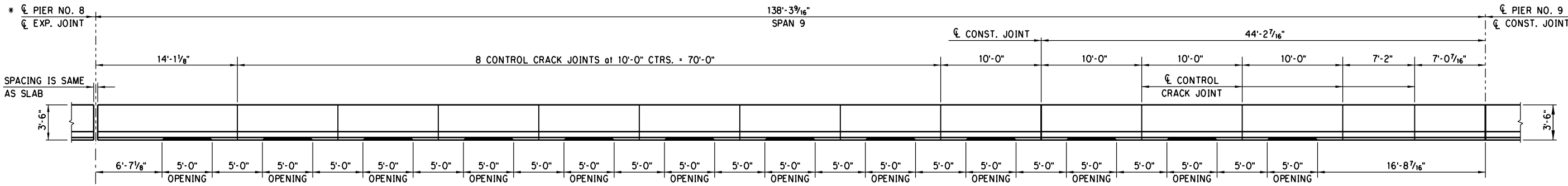

SOUTHWEST PARAPET OPENINGS AND JOINT SPACING
SPAN NO. 9
(DIMENSIONS SHOWN ARE ϕ PIER TO ϕ PIER ALONG OUTSIDE EDGE OF SLAB)

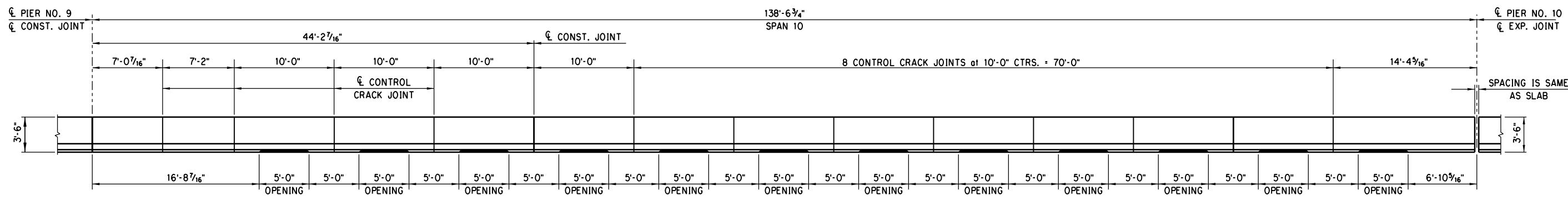

SOUTHWEST PARAPET OPENINGS AND JOINT SPACING
SPAN NO. 10
(DIMENSIONS SHOWN ARE ϕ PIER TO ϕ PIER ALONG OUTSIDE EDGE OF SLAB)

NOTE: FOR ADDITIONAL DETAILS,
SEE STD. FSHP-42-2.

DESIGN		BRIDGE "A"	RAMP "A" AT I-35 & I-240 INTERCHANGE
DRAWN		PARAPET LAYOUT (SHEET 3 OF 4) STATE JOB NO. <u>09032(08)</u> SHEET NO. <u>B045</u>	
CHECKED			
APPROVED			
SQUAD	POE		

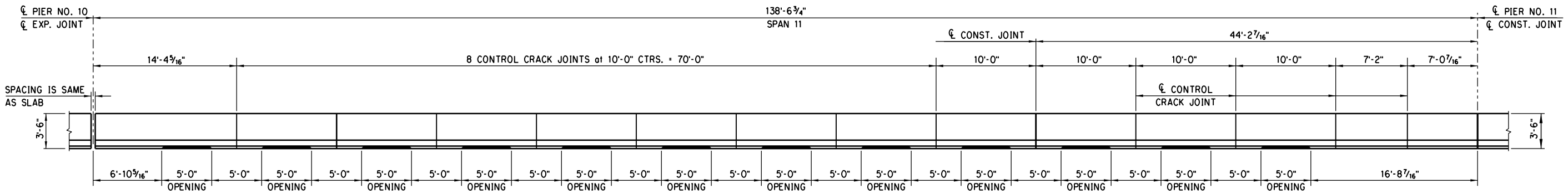

SOUTHWEST PARAPET OPENINGS AND JOINT SPACING
SPAN NO. 11
(DIMENSIONS SHOWN ARE ϕ PIER to ϕ PIER ALONG OUTSIDE EDGE OF SLAB)

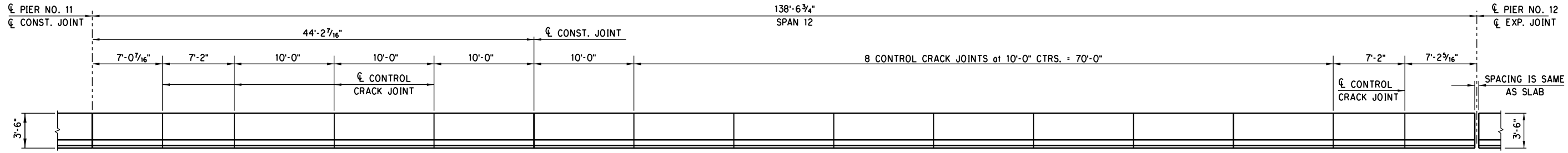

SOUTHWEST PARAPET JOINT SPACING
SPAN NO. 12
(DIMENSIONS SHOWN ARE ϕ PIER to ϕ PIER ALONG OUTSIDE EDGE OF SLAB)

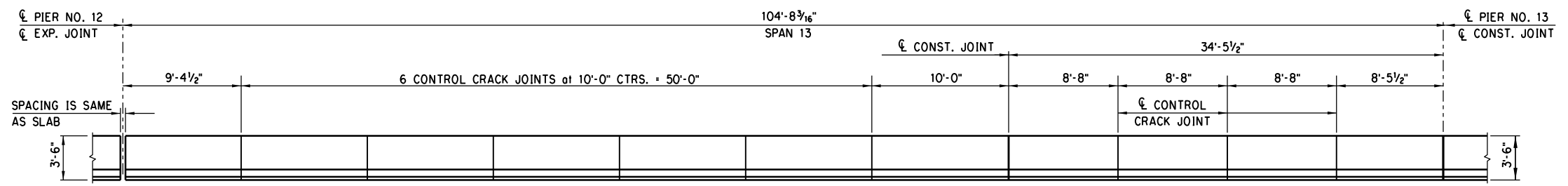

SOUTHWEST PARAPET JOINT SPACING
SPAN NO. 13
(DIMENSIONS SHOWN ARE ϕ PIER to ϕ PIER ALONG OUTSIDE EDGE OF SLAB)

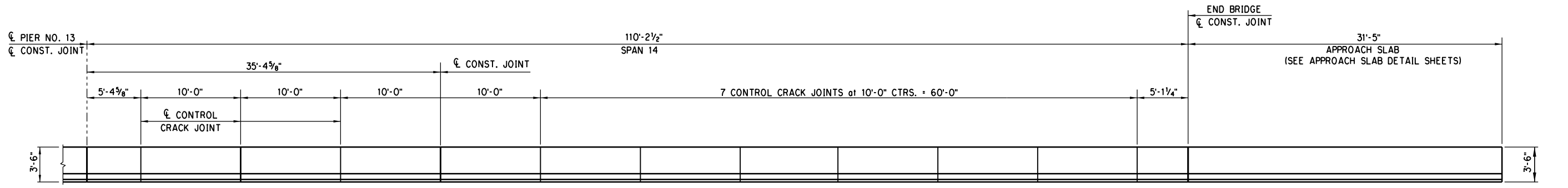

SOUTHWEST PARAPET JOINT SPACING
SPAN NO. 14
(DIMENSIONS SHOWN ARE ϕ PIER to ϕ PIER ALONG OUTSIDE EDGE OF SLAB)

NOTE: FOR ADDITIONAL DETAILS,
SEE STD. FSHP-42-2.

PHASE 4		OKLAHOMA COUNTY	
BRIDGE "A"		RAMP "A" AT I-35 & I-240 INTERCHANGE	
PARAPET LAYOUT			
(SHEET 4 OF 4)			
STATE JOB NO. 09032108		SHEET NO. B046	

3/1/2024 3:21:01 PM H:\PROJECTS\2789_Crossroads_Phase 4\Bridges\Drawings\Ph4 Bridges\Bridges\Bridges A Parapet Layout.dgn

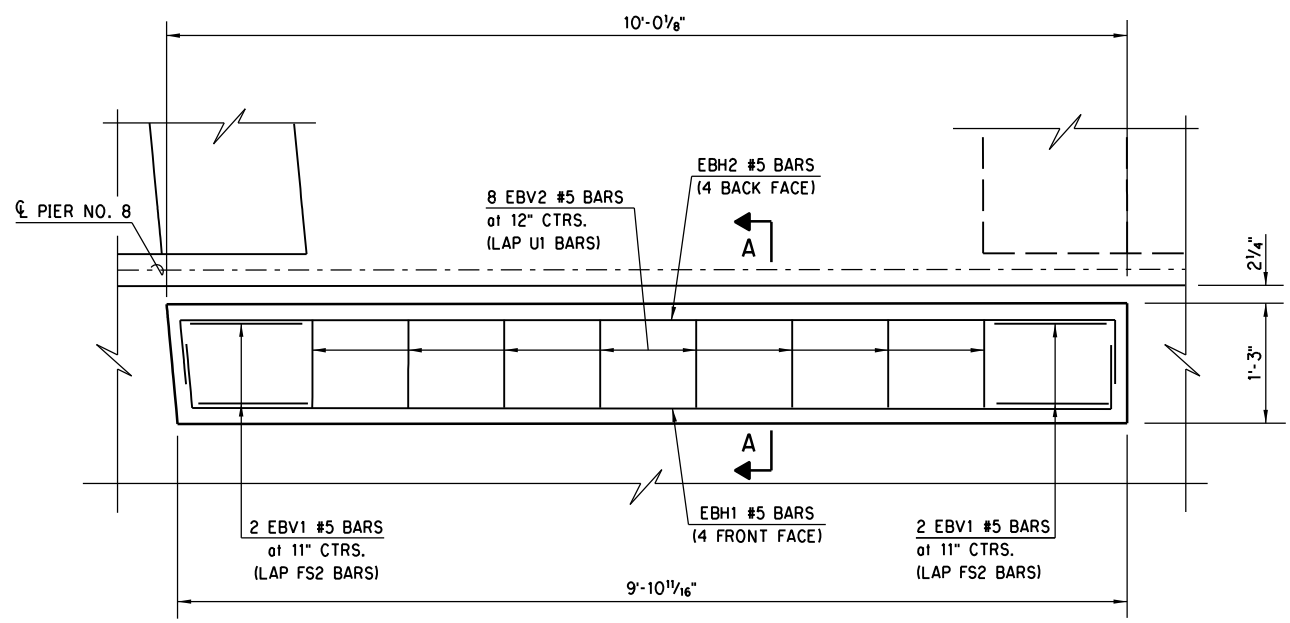

PLAN

NOTE: FOR U1 AND FS2 BAR DETAILS
SEE "SUPERSTRUCTURE DETAILS" SHEET 4 OF 7.

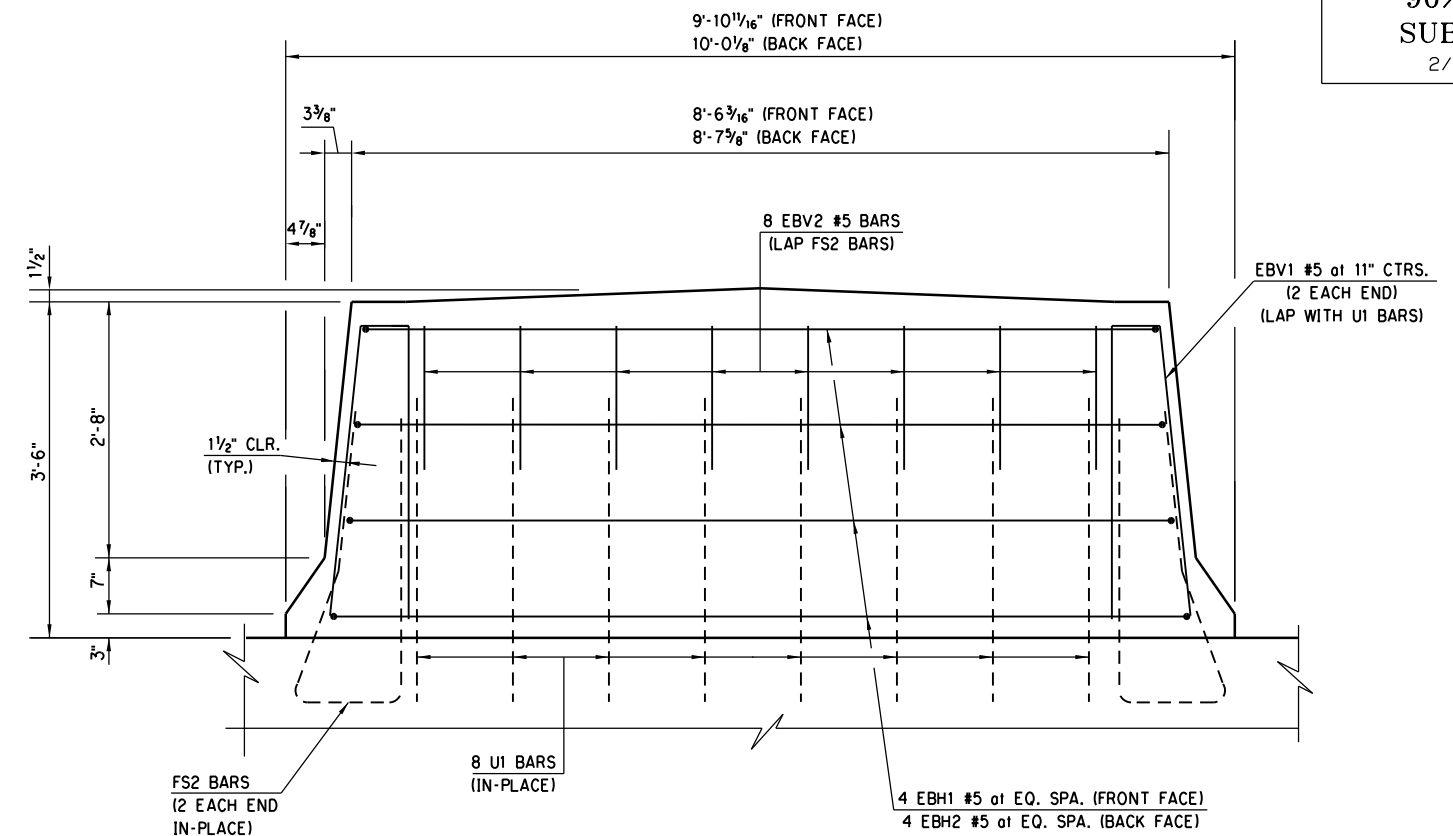

ELEVATION

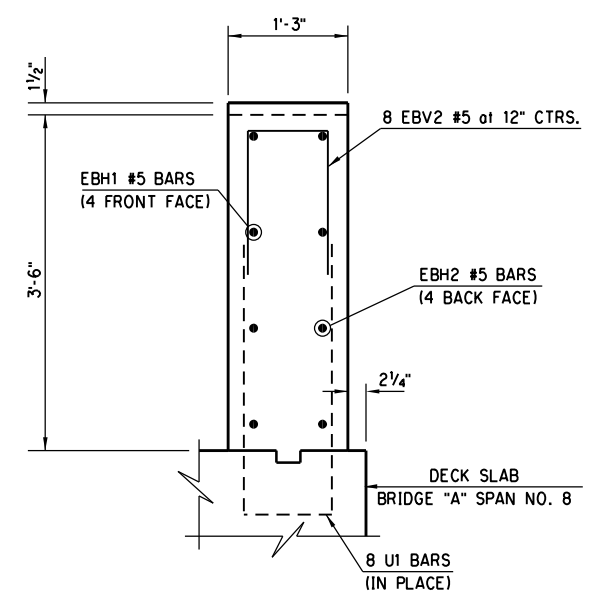

SECTION A-A

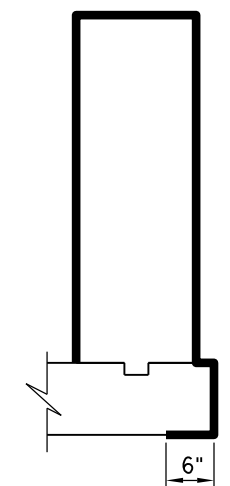

**WATER REPELLENT
SURFACE TREATMENT**

SURFACES INDICATED WITH HEAVY LINES
SHALL BE TREATED WITH A PENETRATING
WATER REPELLENT SEALER.

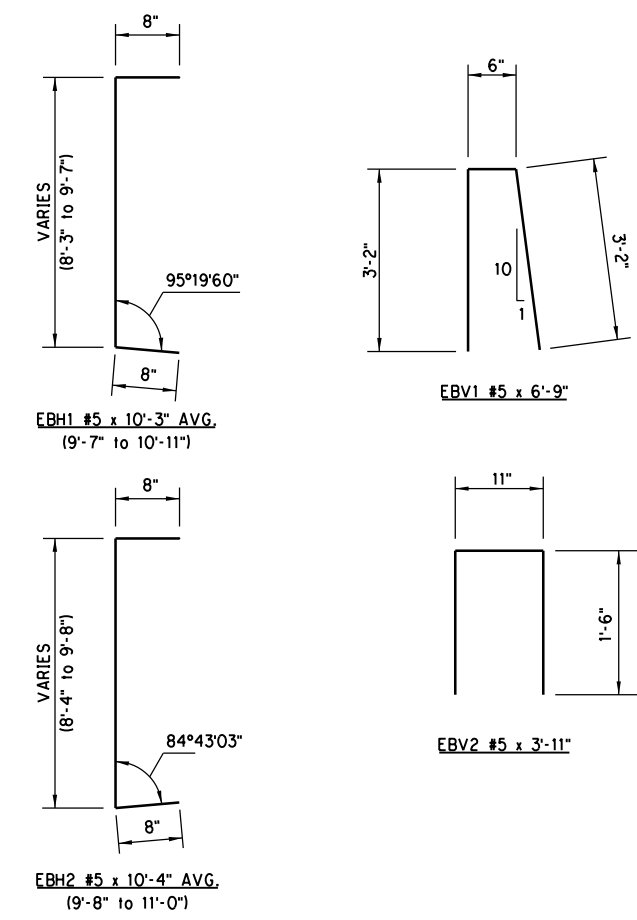

ALL BAR BEND DIMENSIONS ARE OUT TO OUT.

END BARRIER BAR LIST (EPOXY COATED)						
MARK	NO.	SIZE	FORM	SPACING	LENGTH	LENGTH VARIATION
EBH1	4	#5	BENT	EQUAL	10'-3" AVG.	9'-7" TO 10'-11"
EBH2	4	#5	BENT	EQUAL	10'-4" AVG.	9'-8" TO 11'-0"
EBV1	4	#5	BENT	11" C/C	6'-9"	--
EBV2	8	#5	BENT	12" C/C	3'-11"	--

END BARRIER QUANTITIES (FOR INFORMATION ONLY)		
ITEM	UNIT	TOTAL
CLASS A CONCRETE	C.Y.	1.50
EPOXY COATED REINFORCING STEEL	LB.	150.00
WATER REPELLENT (VISUALLY INSPECTED)	S.Y.	11.00

NOTE:
ALL QUANTITIES LISTED ARE INCLUDED IN SUPERSTRUCTURE QUANTITIES.

PHASE 4
BRIDGE "A" RAMP "A" AT I-35 & I-240 INTERCHANGE

OKLAHOMA COUNTY

END BARRIER LAYOUT

STATE JOB NO. 09032(08) SHEET NO. B047

DESIGN	
DRAWN	
CHECKED	
APPROVED	
SQUAD	POE

3/1/2024 3:21:03 PM H:\PROJECTS\2789_CrossRoads_Phase 4\Bridges\Drawings\Ph4 Bridges\Bridges\Bridges A Endbarrier.dgn

BRACING SYSTEM SHOWN FOR ILLUSTRATION PURPOSES ONLY. ALTERNATIVE SYSTEMS MAY BE CONSIDERED. SEE GENERAL NOTES FOR DESIGN REQUIREMENTS AND LIMITATIONS.

① SPACING OF FORMING BRACES, TENSION TIES, AND HARDWOOD STRUTS TO BE DETERMINED BY A PROFESSIONAL ENGINEER LICENSED IN THE STATE OF OKLAHOMA FOR THE LOADS ANTICIPATED DURING CONSTRUCTION. SEE GENERAL NOTES FOR ADDITIONAL DETAILS.

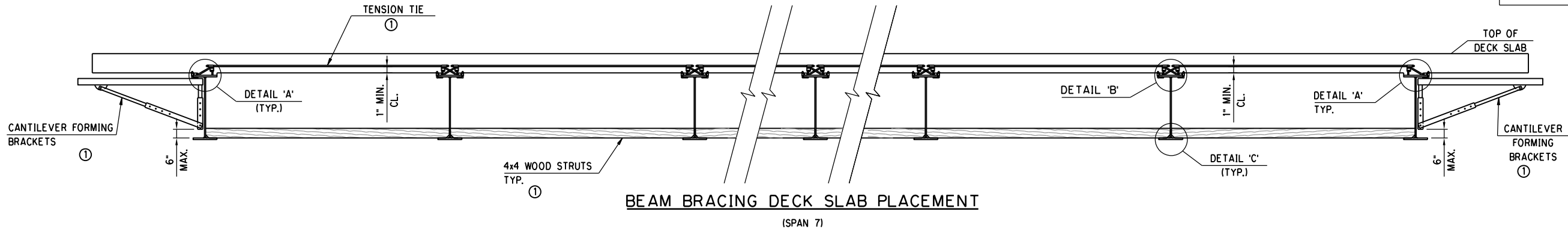

BEAM BRACING DECK SLAB PLACEMENT

(SPAN 7)

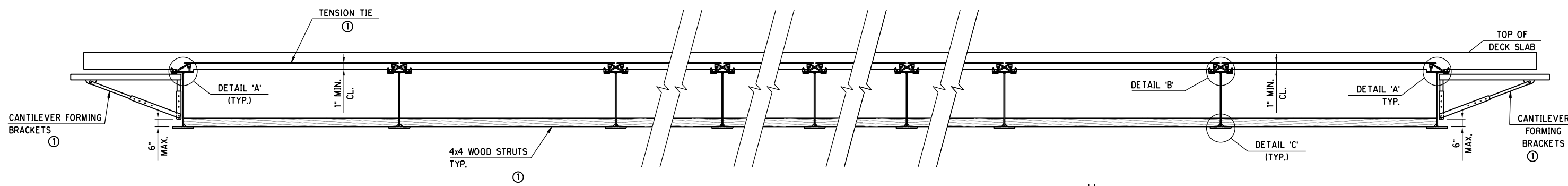

BEAM BRACING DECK SLAB PLACEMENT

(SPAN 8)

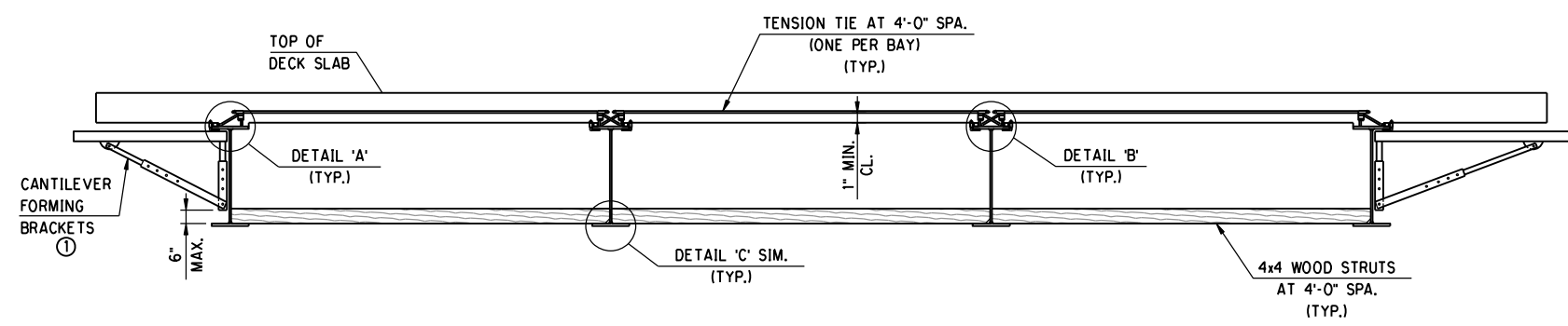

BEAM BRACING FOR DECK SLAB PLACEMENT

(SPANS 9 THRU 14)

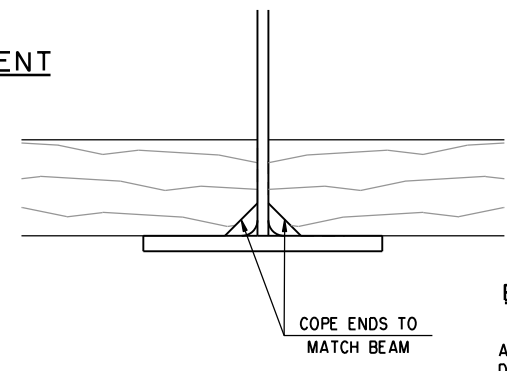

DETAIL 'C'

BRACING NOTES

SUBMIT DRAWINGS OF THE BRACING SYSTEM TO THE BRIDGE ENGINEER FOR APPROVAL. BRACING SYSTEMS OTHER THAN THAT SHOWN MAY BE USED IF DESIGN CALCULATIONS AND DRAWINGS OF THE PROPOSED BRACING SYSTEM ARE SUBMITTED TO AND APPROVED BY THE BRIDGE ENGINEER. DRAWINGS AND CALCULATIONS OF THE PROPOSED SYSTEM SHALL BE SIGNED AND SEALED BY A PROFESSIONAL ENGINEER LICENSED IN THE STATE OF OKLAHOMA. DO NOT PLACE SLAB CONCRETE UNTIL BRACING SYSTEM IS APPROVED. THE DEPARTMENT CONSIDERS ALL COST FOR BRACING TO BE INCLUDED IN OTHER ITEMS OF WORK.

USE ADJUSTABLE CANTILEVER FORMING BRACKETS AT EXTERIOR BEAMS CAPABLE OF BEING ADJUSTED DURING THE PLACEMENT OF DECK SLAB CONCRETE IN ORDER TO MAINTAIN PROPER GRADES AT THE DECK OVERHANG. IF SHIMS ARE TO BE USED TO ADJUST THE FORMING BRACKETS, PROVIDE THE BRIDGE ENGINEER A METHOD TO PREDICT CRUSH AND SETTLEMENT OF SHIMS. BEAR THE LEG BRACE OF THE BRACKETS ON THE BEAM WEB WITHIN 6 INCHES OF THE BOTTOM FLANGE.

TENSION TIES SHALL BE A MINIMUM #4 EPOXY-COATED REINFORCING STEEL BARS WITH THREADED ENDS OR 1/2" DIA. GALVANIZED ALL-THREAD, FURNISHED BY THE CONTRACTOR. THE TENSION TIES SHALL BE PLACED PERPENDICULAR TO THE GIRDERS. TENSION TIES SHALL BE ATTACHED TO THE TOP FLANGE OF GIRDERS BY MEANS OF TY-BAR CLIPS AS SHOWN ON THE DETAILS. WELDING OF CLIPS TO THE TOP FLANGE OF GIRDERS WILL NOT BE PERMITTED.

WOOD STRUTS SHALL BE HARDWOOD OR OF AN EQUIVALENT STRENGTH MATERIAL. WEDGE STRUTS BETWEEN GIRDER WEBS WITHIN 6" OF THE BOTTOM FLANGE OF EACH GIRDER. LOCATE WOOD STRUTS WHERE THE TOP OF THE GIRDERS ARE TIED TOGETHER WITH TENSION TIES.

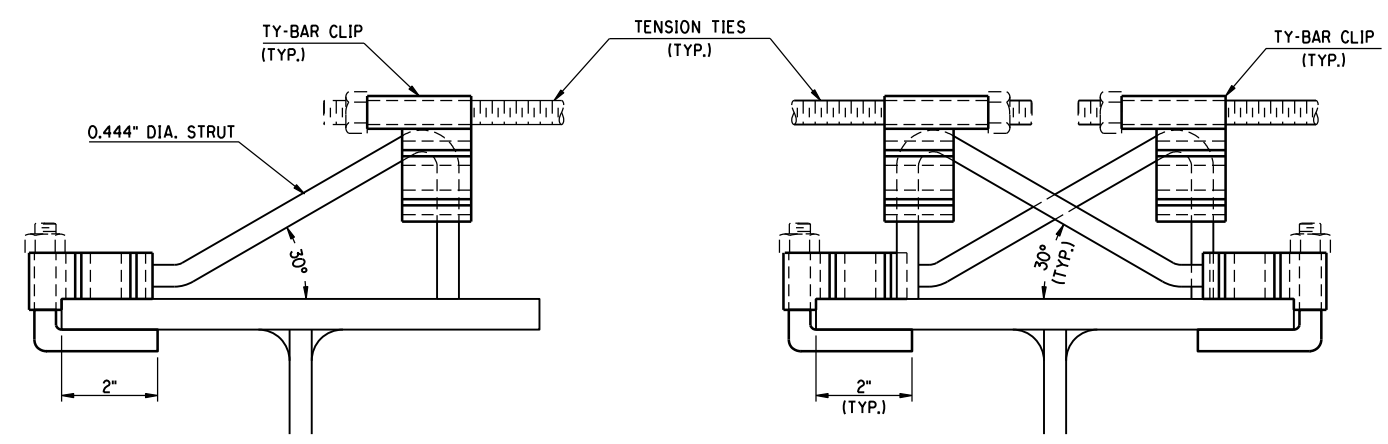

DETAIL 'A'

DETAIL 'B'

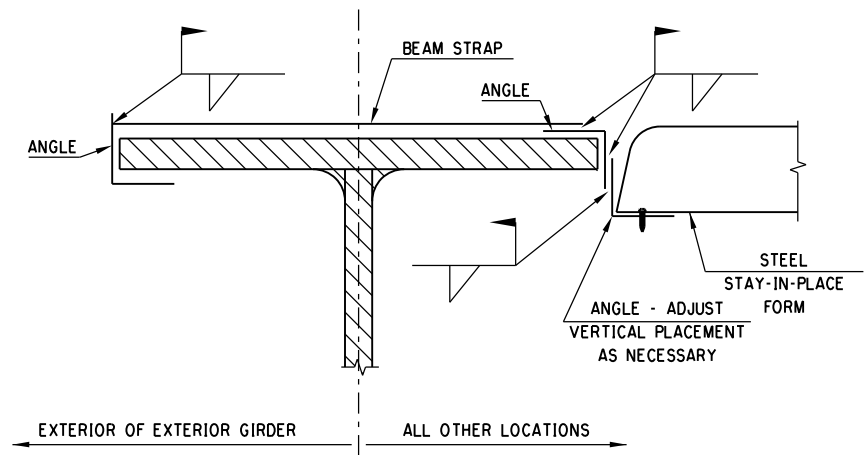

**STEEL STAY-IN-PLACE FORMS
FLANGE CONNECTION DETAIL**

REPORT ANY ARC STRIKE, WELD SPLATTER OR WELDING ON TOP FLANGE TO BRIDGE ENGINEER IMMEDIATELY.

DESIGN		PHASE 4	OKLAHOMA COUNTY
DRAWN		BRIDGE "A"	RAMP "A" AT I-35 & I-240 INTERCHANGE
CHECKED		GIRDER BRACING DETAILS	
APPROVED			
SQUAD	POE		
		STATE JOB NO. 09032(06)	SHEET NO. B048

3/1/2024 3:26:05 PM H:\PROJECTS\2789_CrossRoads_Phase 4\Bridges\Drawings\PH4_Bridges\Bridges\Bridges A\0903208 P4 Bridge A BmBrace.dgn

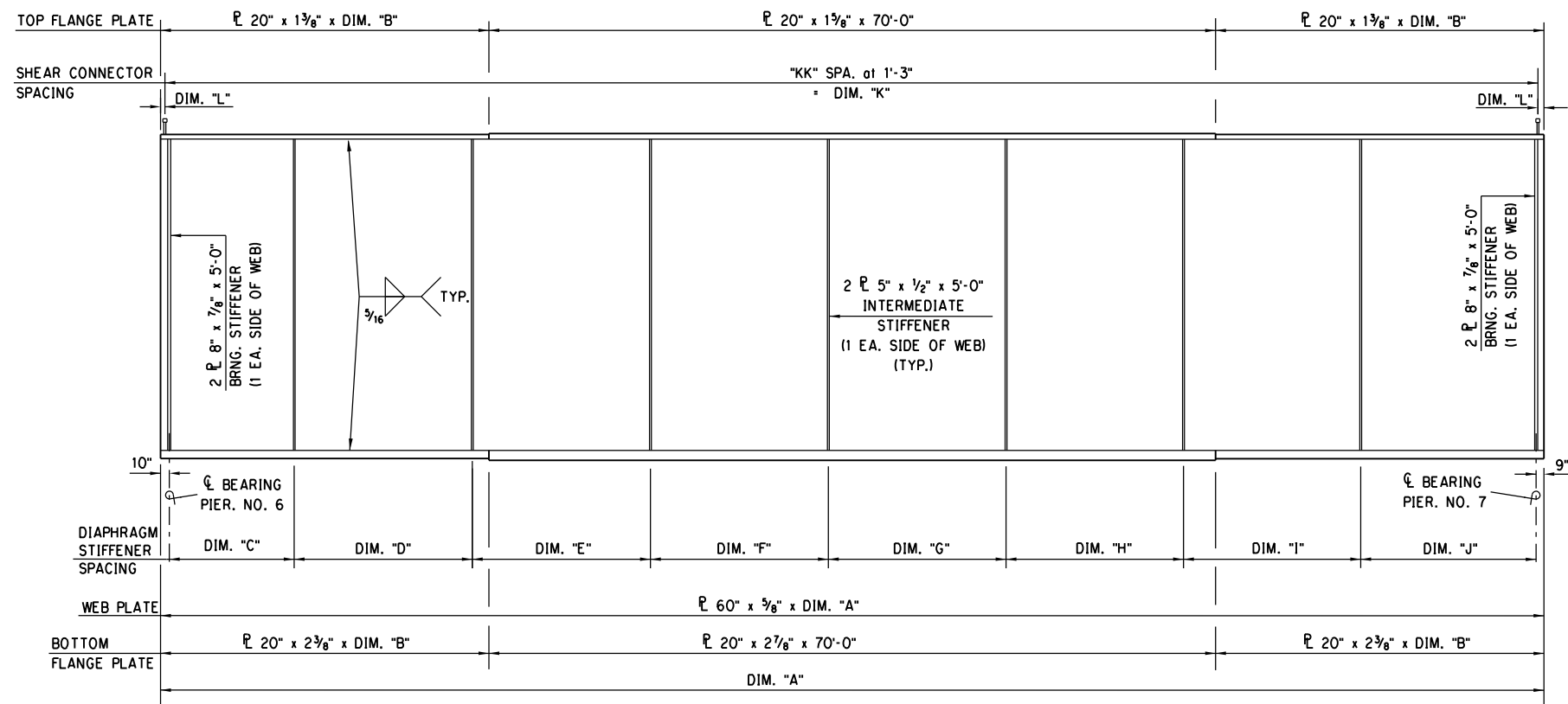
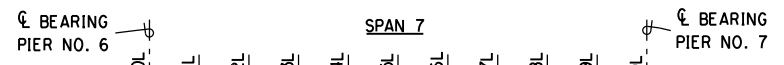

PLATE GIRDER ELEVATION SPAN 7



GIRDER LINE	DECK SLAB, HAUNCH, RAIL & 5 psf SIP FORMS (IN INCHES)										TOTAL DEFLECTION (NO FUTURE WEARING SURFACE) (IN INCHES)											
	A	B	C	D	E	F	G	A	B	C	D	E	F	G								
A	0.00	0.76	1.42	1.93	2.25	2.36	2.25	1.94	1.43	0.76	0.00	0.00	1.08	2.03	2.75	3.21	3.36	3.21	2.76	2.04	1.09	0.00
B	0.00	0.89	1.67	2.26	2.63	2.76	2.64	2.27	1.68	0.89	0.00	0.00	1.26	2.37	3.21	3.75	3.93	3.75	3.22	2.38	1.27	0.00
C	0.00	1.01	1.90	2.57	2.99	3.14	3.00	2.58	1.91	1.01	0.00	0.00	1.44	2.70	3.65	4.26	4.47	4.26	3.66	2.70	1.44	0.00
D	0.00	1.13	2.12	2.87	3.34	3.51	3.35	2.88	2.13	1.13	0.00	0.00	1.60	3.01	4.08	4.75	4.99	4.76	4.08	3.02	1.61	0.00
E	0.00	1.24	2.34	3.17	3.69	3.87	3.70	3.18	2.35	1.24	0.00	0.00	1.77	3.32	4.51	5.25	5.51	5.25	4.51	3.33	1.77	0.00
F	0.00	1.36	2.56	3.48	4.05	4.25	4.06	3.49	2.58	1.36	0.00	0.00	1.94	3.65	4.95	5.77	6.05	5.77	4.96	3.66	1.95	0.00
G	0.00	1.49	2.80	3.80	4.43	4.65	4.44	3.82	2.82	1.49	0.00	0.00	2.12	3.99	5.41	6.31	6.62	6.32	5.43	4.01	2.13	0.00

DEAD LOAD DEFLECTION DIAGRAM AND DEFLECTION SCHEDULE

GIRDER	SPAN 7 GIRDER DIMENSION SCHEDULE													
	DIM "A"	DIM "B"	DIM "C"	DIM "D"	DIM "E"	DIM "F"	DIM "G"	DIM "H"	DIM "I"	DIM "J"	"KK"	DIM "K"	DIM "L"	CURVE RADIUS
A	133'-3 1/4"	31'-7 5/8"	12'-0 1/2"	17'-2"	17'-1 7/8"	17'-1 5/8"	17'-1 3/8"	17'-1 1/4"	17'-1"	16'-10 5/8"	106	132'-6"	4 5/8"	816.26'
B	135'-0 3/8"	32'-6 3/16"	12'-11 3/4"	17'-3 3/8"	17'-3 1/4"	17'-3"	17'-2 7/8"	17'-2 5/8"	17'-2 3/8"	17'-0 1/8"	107	133'-9"	7 11/16"	856.70'
C	136'-9 7/8"	33'-4 15/16"	13'-10 7/8"	17'-4 3/4"	17'-4 5/8"	17'-4 3/8"	17'-4 1/4"	17'-4 1/8"	17'-4"	17'-1 7/8"	109	136'-9"	3 7/16"	897.13'
D	138'-7 3/4"	34'-3 7/8"	14'-10"	17'-6 1/8"	17'-6 1/8"	17'-6"	17'-5 3/4"	17'-5 3/4"	17'-5 1/2"	17'-3 1/2"	110	137'-9"	6 7/8"	937.57'
E	140'-6"	35'-3"	15'-9 1/4"	17'-7 5/8"	17'-7 1/2"	17'-7 1/2"	17'-7 3/8"	17'-7 1/4"	17'-7 1/4"	17'-5 1/4"	112	140'-0"	3"	978.01'
F	142'-4 1/2"	36'-2 1/4"	16'-8 3/8"	17'-9 1/8"	17'-9 1/8"	17'-9"	17'-9"	17'-8 7/8"	17'-8 7/8"	17'-7 1/8"	113	141'-3"	6 3/4"	1018.44'
G	144'-3 3/8"	37'-1 11/16"	17'-7 5/8"	17'-10 5/8"	17'-10 5/8"	17'-10 5/8"	17'-10 5/8"	17'-10 5/8"	17'-10 5/8"	17'-8 5/8"	115	143'-9"	3 3/16"	1058.88'

GIRDER	DECK SLAB ELEVATION SCHEDULE AT 10TH POINTS											
	SPAN 7											PIER 7 BRNG.
	PIER 6 BRNG.	0.1L	0.2L	0.3L	0.4L	0.5L	0.6L	0.7L	0.8L	0.9L		
A	1322.72	1322.84	1322.94	1323.03	1323.12	1323.19	1323.25	1323.30	1323.33	1323.36	1323.38	
B	1323.14	1323.27	1323.38	1323.49	1323.58	1323.66	1323.73	1323.80	1323.85	1323.89	1323.92	
C	1323.56	1323.70	1323.82	1323.94	1324.04	1324.14	1324.22	1324.30	1324.36	1324.42	1324.46	
D	1323.98	1324.13	1324.26	1324.39	1324.51	1324.61	1324.71	1324.80	1324.88	1324.94	1325.00	
E	1324.40	1324.56	1324.71	1324.84	1324.97	1325.09	1325.20	1325.30	1325.39	1325.47	1325.54	
F	1324.82	1324.99	1325.15	1325.30	1325.44	1325.57	1325.69	1325.80	1325.91	1326.00	1326.09	
G	1325.24	1325.42	1325.59	1325.75	1325.90	1326.05	1326.18	1326.31	1326.42	1326.53	1326.63	

3/1/2024 3:21:06 PM H:\PROJECTS\2789_CrossRoads_Phase 4\Bridges\Drawings\Phase 4\Bridges\Bridges\Bridges A\0903208 P4 Bridge A StGir-dr.dgn

DESIGN		PHASE 4		OKLAHOMA COUNTY	
DRAWN		BRIDGE "A"		RAMP "A" AT I-35 & I-240 INTERCHANGE	
CHECKED		PLATE GIRDER DETAILS			
APPROVED		SPAN 7			
SQUAD		POE			
		STATE JOB NO. 09032(08) SHEET NO. B049			

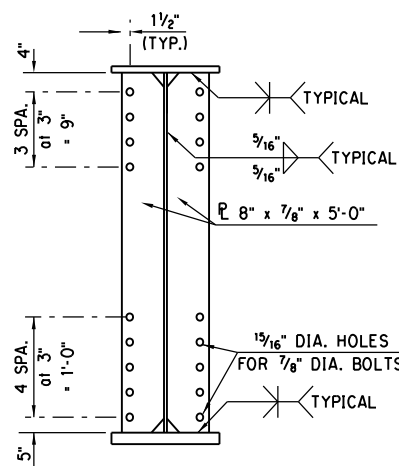

BEARING STIFFENER
PIERS NO. 6 AND 7

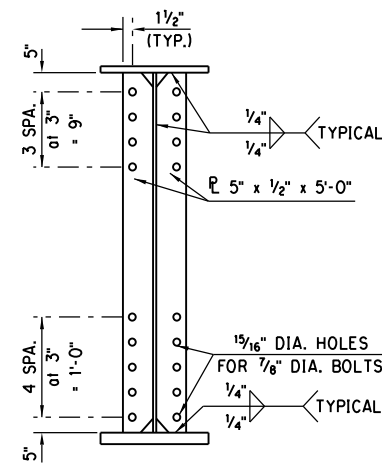

INTERMEDIATE STIFFENER

NOTE: SEE PLATE GIRDER ELEVATION, SHEET 1 OF 2 AND "FRAMING PLAN & DIAPHRAGM DETAILS", SHEET 1 OF 3 FOR LOCATIONS OF STIFFENERS.

OMIT BOLT HOLES ON EXTERIOR STIFFENERS ON EXTERIOR GIRDERS.

NOTES:

ALL GIRDER, STIFFENER AND SPLICE PLATES SHALL BE AASHTO M270. (ASTM A709) GRADE 50WT2.

ALL GIRDER, STIFFENER AND SPLICE PLATES SHALL CONFORM TO THE NON-FRACTURE CRITICAL CHARPY V-NOTCH TESTED FOR ZONE 2.

USE SHEAR CONNECTORS CONFORMING TO AASHTO M169 (ASTM A108) GRADE 1015, 1018, 1020.

PROVIDE WELDING WITH WEATHERING CHARACTERISTICS.

ALL HIGH STRENGTH BOLTS SHALL BE 7/8" DIA. CONFORMING TO AASHTO M164 (ASTM A325) TYPE 3 (WEATHERING) WITH HEAVY HEX NUTS, CONFORMING TO AASHTO M291 (ASTM A563), PROPERTY CLASS 8S3 OR 10S3, AND HARDENED CIRCULAR WASHERS, CONFORMING TO AASHTO M293 (ASTM F436) TYPE 3 (WEATHERING) WITH 13/16" DIA. HOLES, UNLESS OTHERWISE NOTED.

SPLICE BOLTS SHALL BE PLACED WITH HEADS ON THE OUTSIDE FACE OF EXTERIOR GIRDERS AND ON BOTTOM OF GIRDER FLANGES.

BOLT THREADS MUST BE EXCLUDED FROM FIELD SPLICE SHEAR PLANES.

NO FIELD WELDING TO GIRDERS WILL BE ALLOWED EXCEPT AS SHOWN ON PLANS.

GIRDERS ARE SHOWN AND DIMENSIONED WITH TOP FLANGE IN THE HORIZONTAL POSITION. VERTICAL CURVATURE AND EFFECTS OF DEAD LOAD DEFLECTION HAVE NOT BEEN TAKEN INTO CONSIDERATION. SHOP DRAWINGS SHALL INCLUDE BLOCKING DIAGRAM FOR EACH GIRDER SHOWING ALL ADJUSTMENTS NECESSARY FOR DEAD LOAD DEFLECTION AND VERTICAL CURVATURE. THE WEB PLATES SHALL BE FABRICATED WITH CAMBER FOR DEAD LOAD DEFLECTION AND VERTICAL CURVATURE.

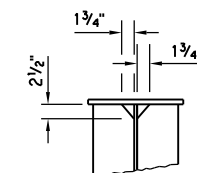
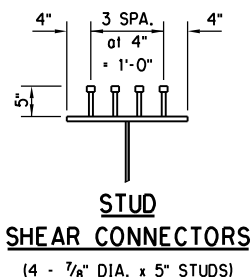

NOTE: TERMINATE FILLET WELDS 3/8" FROM THE EDGE OF CLIPPED CORNERS OF ALL STIFFENER PLATES AND NON-CLIPPED CORNERS OF INTERMEDIATE DIAPHRAGM STIFFENERS. WRAP FILLET WELDS AROUND NON-CLIPPED CORNERS OF BEARING STIFFENERS.

DESIGN		PHASE 4	OKLAHOMA COUNTY
DRAWN		BRIDGE "A"	RAMP "A" AT I-35 & I-240 INTERCHANGE
CHECKED		PLATE GIRDER DETAILS SPAN 7 (SHEET 2 OF 2)	
APPROVED			
SQUAD	POE	STATE JOB NO. 090321081	SHEET NO. B050

90% PLAN
SUBMITTAL
2/29/2024

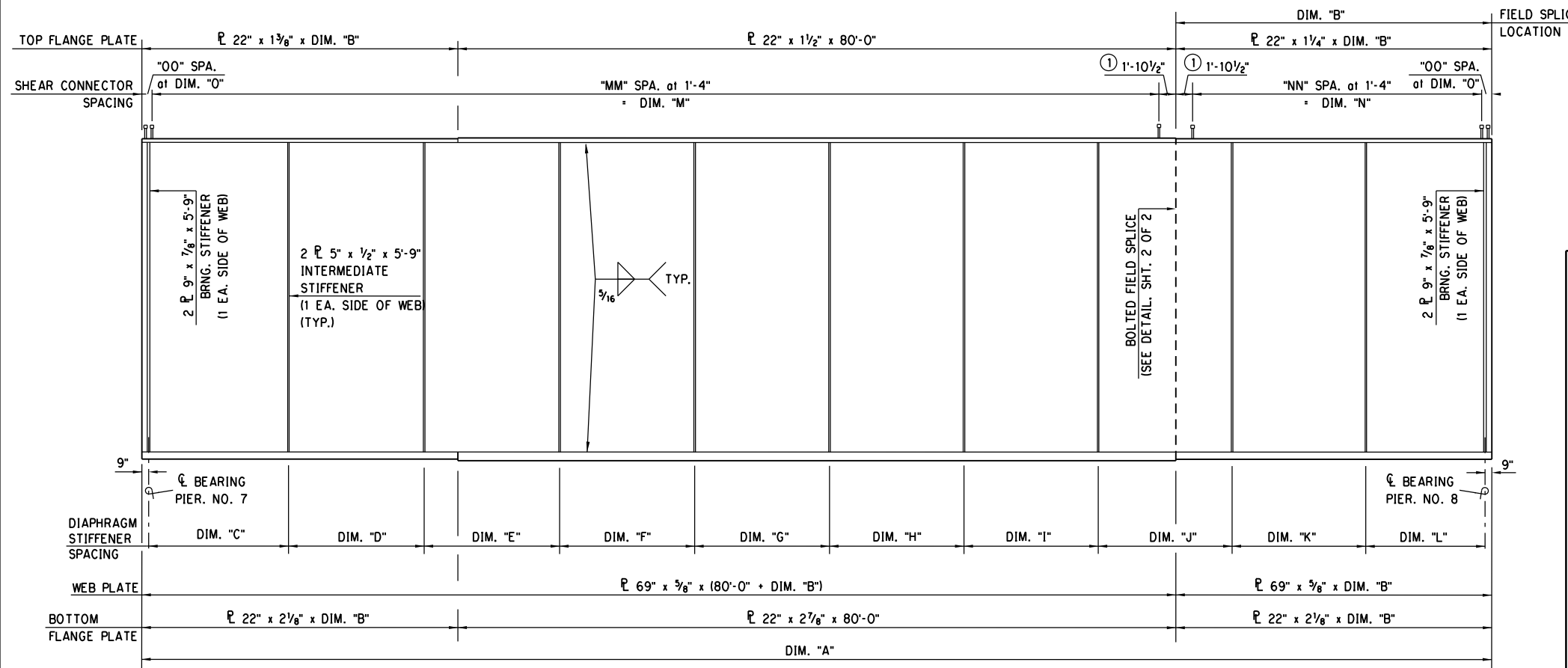

PLATE GIRDER ELEVATION SPAN 8

① STUD SPACING THROUGH FIELD SPLICE (SEE DETAIL SHEET 2 OF 2)

NOTE: GIRDER DIMENSIONS ARE ALONG ϕ ARC OF WEB.

GIRDER	SPAN 8 GIRDER DIMENSION SCHEDULE																			
	DIM "A"	DIM "B"	DIM "C"	DIM "D"	DIM "E"	DIM "F"	DIM "G"	DIM "H"	DIM "I"	DIM "J"	DIM "K"	DIM "L"	"MM"	DIM "M"	"NN"	DIM "N"	"OO"	DIM "O"	CURVE RADIUS	
A	150'-4 1/4"	35'-2 1/8"	15'-7"	15'-1 1/2"	15'-1"	15'-0 5/8"	15'-0 1/4"	14'-11 7/8"	14'-11 3/8"	14'-11 1/8"	14'-10 3/4"	13'-2 3/4"	84	112'-0"	24	32'-0"	2	7 13/16"	816.26'	
B	151'-9 3/4"	35'-10 7/8"	15'-7 1/2"	15'-2 7/8"	15'-2 1/2"	15'-2 1/4"	15'-1 7/8"	15'-1 1/2"	15'-1 1/8"	15'-0 7/8"	15'-0 1/2"	13'-6 3/4"	85	113'-4"	25	33'-4"	2	4 3/16"	816.72'	
C	153'-3 1/2"	36'-7 3/4"	15'-8"	15'-4 3/8"	15'-4 1/8"	15'-3 3/4"	15'-3 1/2"	15'-3 1/8"	15'-2 7/8"	15'-2 5/8"	15'-2 1/4"	13'-10 7/8"	85	113'-4"	25	33'-4"	2	8 5/8"	817.20'	
D	154'-9 3/4"	37'-4 7/8"	15'-8 5/8"	15'-5 7/8"	15'-5 5/8"	15'-5 3/8"	15'-5 1/8"	15'-4 7/8"	15'-4 5/8"	15'-4 3/8"	15'-4 1/4"	14'-3"	86	114'-8"	26	34'-8"	2	5 3/16"	817.66'	
E	156'-4 1/4"	38'-2 1/8"	15'-9 1/4"	15'-7 3/8"	15'-7 1/4"	15'-7"	15'-6 3/4"	15'-6 5/8"	15'-6 1/2"	15'-6 1/4"	15'-6 1/8"	14'-7 1/8"	87	116'-0"	27	36'-0"	1	3 5/8"	818.13'	
F	157'-11"	38'-11 1/2"	15'-9 7/8"	15'-9"	15'-8 7/8"	15'-8 5/8"	15'-8 5/8"	15'-8 3/8"	15'-8 1/4"	15'-8 1/8"	15'-8"	14'-11 1/4"	87	116'-0"	27	36'-0"	2	6 1/2"	818.60'	
G	159'-6 1/4"	39'-9 1/8"	15'-10 1/2"	15'-10 5/8"	15'-10 1/2"	15'-10 3/8"	15'-10 3/8"	15'-10 1/4"	15'-10 1/8"	15'-10"	15'-10"	15'-3 1/2"	88	117'-4"	28	37'-4"	2	3 5/16"	819.07'	
H	161'-1 1/2"	40'-6 3/4"	15'-11 1/4"	16'-0 1/4"	16'-0 1/8"	16'-0 1/8"	16'-0 1/8"	16'-0 1/8"	16'-0"	16'-0"	15'-11 7/8"	15'-7 5/8"	88	117'-4"	28	37'-4"	2	8 1/8"	819.53'	
I	162'-9 3/8"	41'-4 11/16"	15'-11 15/16"	16'-1 15/16"	16'-1 15/16"	16'-1 15/16"	16'-1 15/16"	16'-1 15/16"	16'-1 15/16"	16'-1 15/16"	16'-1 15/16"	15'-11 15/16"	89	118'-8"	29	38'-8"	2	5 1/16"	820.00'	

GIRDER	DECK SLAB ELEVATION SCHEDULE AT 10TH POINTS										
	SPAN 8										
	PIER 7 BRNG.	0.1L	0.2L	0.3L	0.4L	0.5L	0.6L	0.7L	0.8L	0.9L	PIER 8 BRNG.
A	1323.38	1323.38	1323.37	1323.35	1323.31	1323.26	1323.20	1323.12	1323.02	1322.92	1322.80
B	1323.79	1323.80	1323.81	1323.80	1323.77	1323.73	1323.68	1323.61	1323.53	1323.44	1323.33
C	1324.19	1324.22	1324.24	1324.24	1324.23	1324.20	1324.16	1324.11	1324.04	1323.96	1323.86
D	1324.60	1324.64	1324.67	1324.69	1324.69	1324.67	1324.65	1324.60	1324.55	1324.48	1324.39
E	1325.01	1325.06	1325.11	1325.13	1325.13	1325.15	1325.15	1325.13	1325.10	1325.05	1324.92
F	1325.42	1325.49	1325.54	1325.58	1325.61	1325.62	1325.61	1325.59	1325.56	1325.51	1325.45
G	1325.82	1325.91	1325.97	1326.03	1326.06	1326.09	1326.10	1326.09	1326.07	1326.03	1325.98
H	1326.23	1326.33	1326.41	1326.47	1326.52	1326.56	1326.58	1326.58	1326.58	1326.55	1326.51
I	1326.64	1326.75	1326.84	1326.92	1326.98	1327.03	1327.06	1327.08	1327.08	1327.07	1327.04

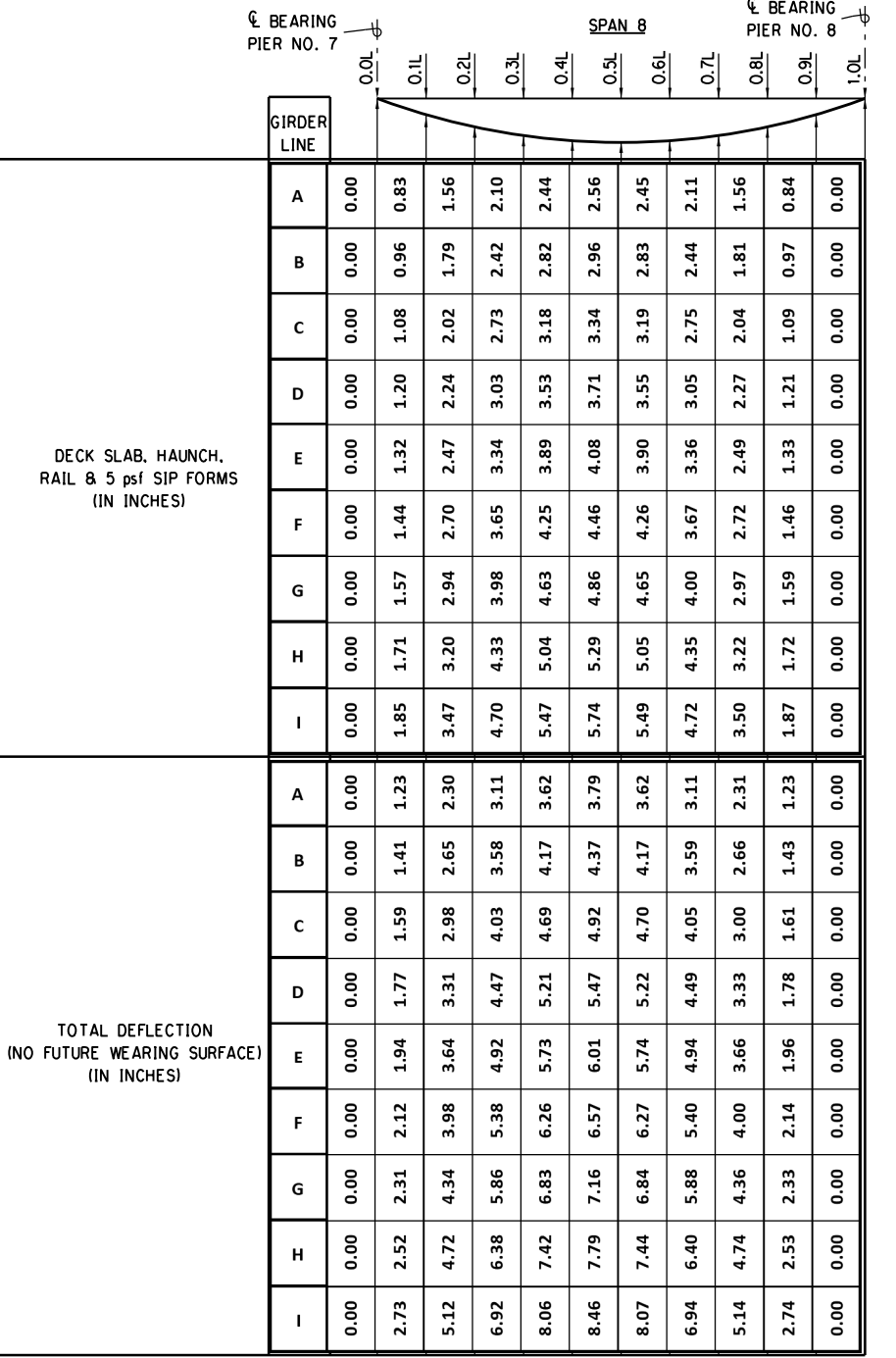

DEAD LOAD DEFLECTION DIAGRAM AND DEFLECTION SCHEDULE

DESIGN		PHASE 4 BRIDGE "A"		OKLAHOMA COUNTY RAMP "A" AT I-35 & I-240 INTERCHANGE	
DRAWN		PLATE GIRDER DETAILS SPAN 8 (SHEET 1 OF 2)			
CHECKED					
APPROVED					
SQUAD	POE				
		STATE JOB NO. 09032(08) SHEET NO. B051			

3/1/2024 3:21:11 PM H:\PROJECTS\2789_CrossRoads_Phase 4\Bridges\Drawings\Plate Girders\Plate Girder A 8-10-18.dgn

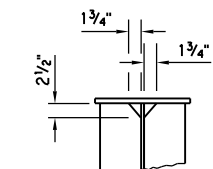

TYP. CORNER CLIP
(ALL STIFFENERS TOP AND BOTTOM)

NOTE: TERMINATE FILLET WELDS 3/8" FROM THE EDGE OF CLIPPED CORNERS OF ALL STIFFENER PLATES AND NON-CLIPPED CORNERS OF INTERMEDIATE DIAPHRAGM STIFFENERS. WRAP FILLET WELDS AROUND NON-CLIPPED CORNERS OF BEARING STIFFENERS.

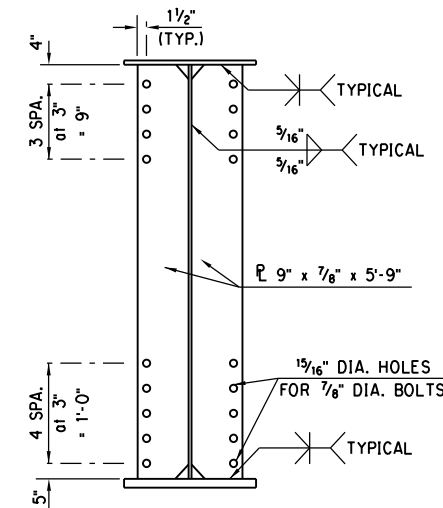

BEARING STIFFENER
PIERS NO. 7 AND 8

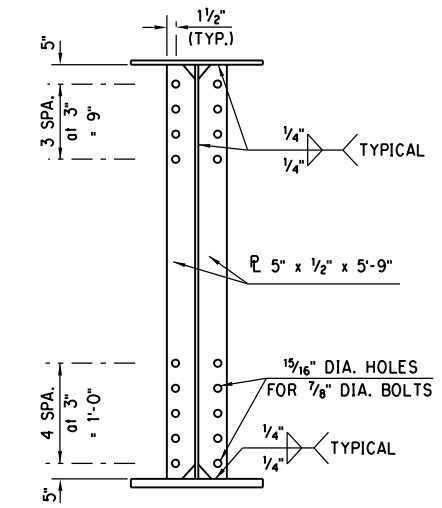

INTERMEDIATE STIFFENER

NOTE: SEE PLATE GIRDER ELEVATION, SHEET 1 OF 2 AND "FRAMING PLAN & DIAPHRAGM DETAILS", SHEET 1 OF 3 FOR LOCATIONS OF STIFFENERS.

OMIT BOLT HOLES ON EXTERIOR STIFFENERS ON EXTERIOR GIRDERS.

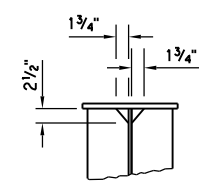

TYP. CORNER CLIP
(ALL STIFFENERS TOP AND BOTTOM)

NOTE: TERMINATE FILLET WELDS 3/8" FROM THE EDGE OF CLIPPED CORNERS OF ALL STIFFENER PLATES AND NON-CLIPPED CORNERS OF INTERMEDIATE DIAPHRAGM STIFFENERS. WRAP FILLET WELDS AROUND NON-CLIPPED CORNERS OF BEARING STIFFENERS.

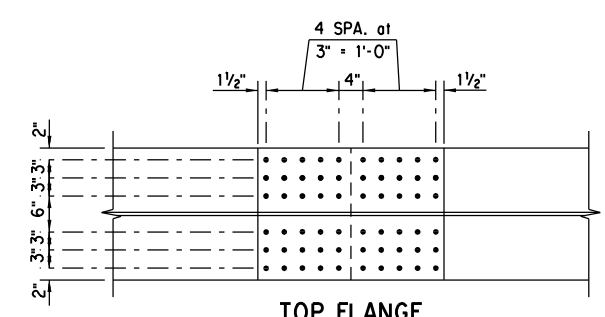

TOP FLANGE

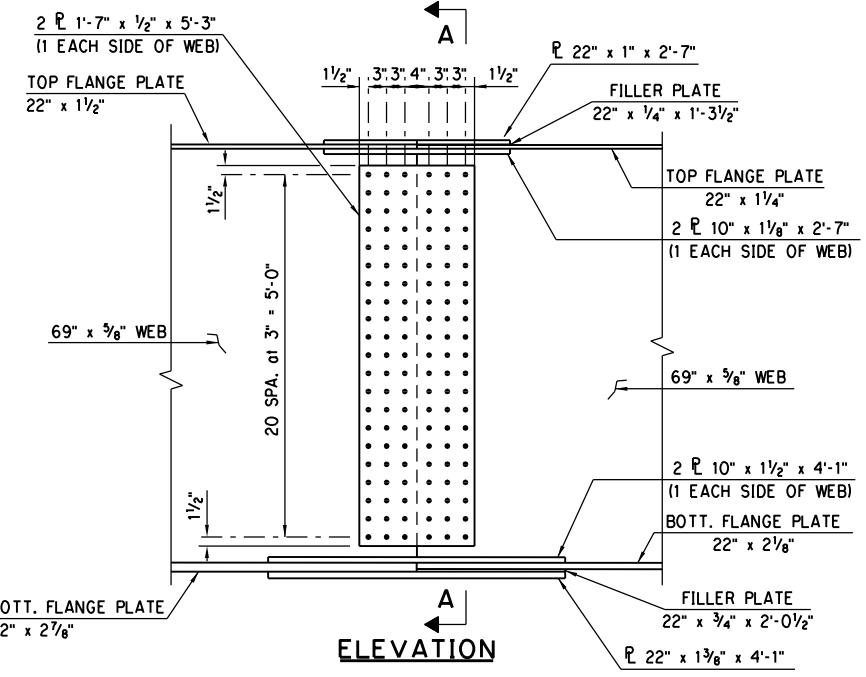

ELEVATION

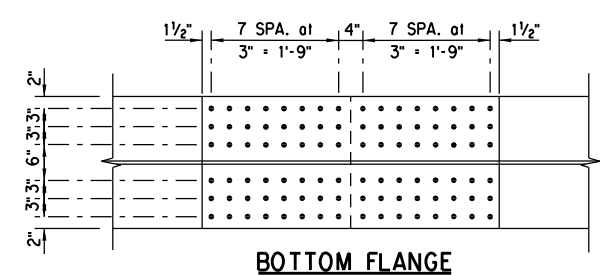

BOTTOM FLANGE

BOLTED FIELD SPLICE DETAIL

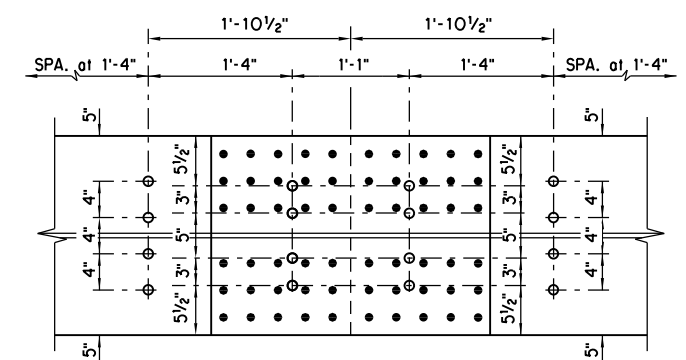

STUD SPACING THROUGH FIELD SPLICE

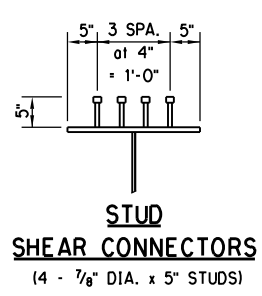

STUD SHEAR CONNECTORS
(4 - 7/8" DIA. x 5" STUDS)

NOTES:

ALL GIRDER, STIFFENER AND SPLICE PLATES SHALL BE AASHTO M270. (ASTM A709) GRADE 50WT2.

ALL GIRDER, STIFFENER AND SPLICE PLATES SHALL CONFORM TO THE NON-FRACTURE CRITICAL CHARPY V-NOTCH TESTED FOR ZONE 2.

USE SHEAR CONNECTORS CONFORMING TO AASHTO M169 (ASTM A108). GRADE 1015, 1018, 1020.

PROVIDE WELDING WITH WEATHERING CHARACTERISTICS.

ALL HIGH STRENGTH BOLTS SHALL BE 7/8" DIA. CONFORMING TO AASHTO M164 (ASTM A325) TYPE 3 (WEATHERING) WITH HEAVY HEX NUTS, CONFORMING TO AASHTO M291 (ASTM A563), PROPERTY CLASS 8S3 OR 10S3, AND HARDENED CIRCULAR WASHERS, CONFORMING TO AASHTO M293 (ASTM F436) TYPE 3 (WEATHERING) WITH 15/16" DIA. HOLES, UNLESS OTHERWISE NOTED.

SPLICE BOLTS SHALL BE PLACED WITH HEADS ON THE OUTSIDE FACE OF EXTERIOR GIRDERS AND ON BOTTOM OF GIRDER FLANGES.

BOLT THREADS MUST BE EXCLUDED FROM FIELD SPLICE SHEAR PLANES.

NO FIELD WELDING TO GIRDERS WILL BE ALLOWED EXCEPT AS SHOWN ON PLANS.

GIRDERS ARE SHOWN AND DIMENSIONED WITH TOP FLANGE IN THE HORIZONTAL POSITION. VERTICAL CURVATURE AND EFFECTS OF DEAD LOAD DEFLECTION HAVE NOT BEEN TAKEN INTO CONSIDERATION. SHOP DRAWINGS SHALL INCLUDE BLOCKING DIAGRAM FOR EACH GIRDER SHOWING ALL ADJUSTMENTS NECESSARY FOR DEAD LOAD DEFLECTION AND VERTICAL CURVATURE. THE WEB PLATES SHALL BE FABRICATED WITH CAMBER FOR DEAD LOAD DEFLECTION AND VERTICAL CURVATURE.

DESIGN		PHASE 4	OKLAHOMA COUNTY
DRAWN		BRIDGE "A"	RAMP "A" AT I-35 & I-240 INTERCHANGE
CHECKED		PLATE GIRDER DETAILS	
APPROVED			
SQUAD	POE	STATE JOB NO. 090321081 SHEET NO. B052	

3/1/2024 3:24:45 PM H:\PROJECTS\2789_CrossRoads_Phase 4\Bridges\Drawings\Phase 4\Bridges\Bridges\Bridges\Bridges\Bridges A Stiffir-dr.dgn

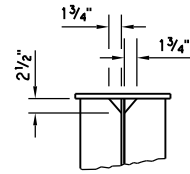

TYP. CORNER CLIP
(ALL STIFFENERS TOP AND BOTTOM)

NOTE: TERMINATE FILLET WELDS $\frac{1}{8}$ " FROM THE EDGE OF CLIPPED CORNERS OF ALL STIFFENER PLATES AND NON-CLIPPED CORNERS OF INTERMEDIATE DIAPHRAGM STIFFENERS. WRAP FILLET WELDS AROUND NON-CLIPPED CORNERS OF BEARING STIFFENERS.

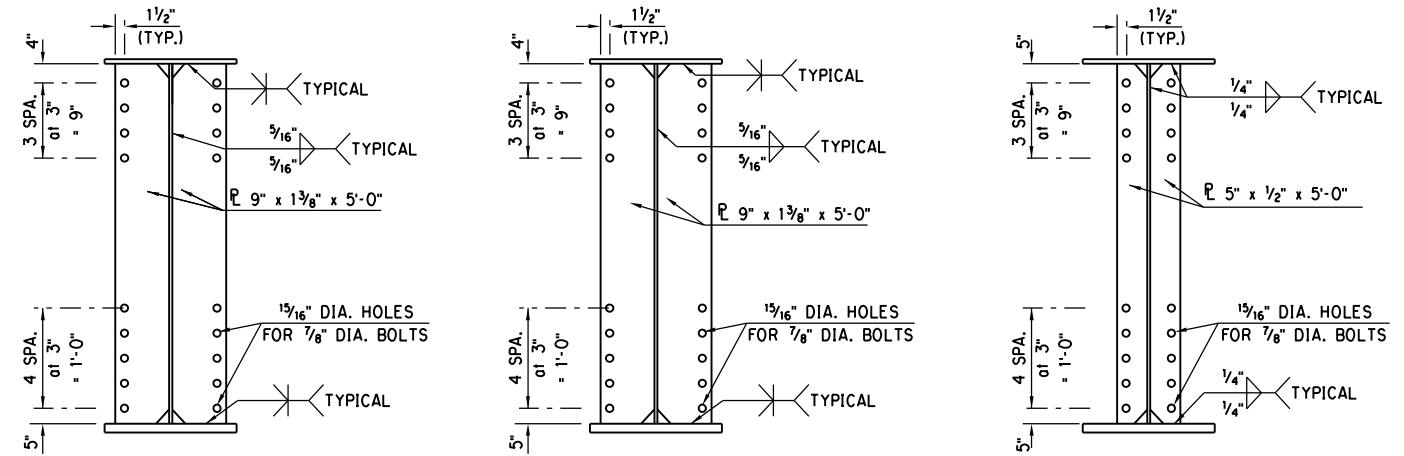

BEARING STIFFENER
PIERS NO. 8 AND 10

BEARING STIFFENER
PIER NO. 9

INTERMEDIATE STIFFENER

NOTE: SEE PLATE GIRDER ELEVATION, SHEET 1 OF 2 AND "FRAMING PLAN & DIAPHRAGM DETAILS", SHEET 2 OF 3 FOR LOCATIONS OF STIFFENERS.

OMIT BOLT HOLES ON EXTERIOR STIFFENERS ON EXTERIOR GIRDERS.

NOTES:

- ALL GIRDER, STIFFENER AND SPLICE PLATES SHALL BE AASHTO M270, (ASTM A709) GRADE 50WT2.
- ALL GIRDER, STIFFENER AND SPLICE PLATES SHALL CONFORM TO THE NON-FRACTURE CRITICAL CHARPY V-NOTCH TESTED FOR ZONE 2.
- USE SHEAR CONNECTORS CONFORMING TO AASHTO M169 (ASTM A108), GRADE 1015, 1018, 1020.
- PROVIDE WELDING WITH WEATHERING CHARACTERISTICS.
- ALL HIGH STRENGTH BOLTS SHALL BE $\frac{7}{8}$ " DIA. CONFORMING TO AASHTO M164 (ASTM A325) TYPE 3 (WEATHERING) WITH HEAVY HEX NUTS, CONFORMING TO AASHTO M291 (ASTM A563), PROPERTY CLASS 8S3 OR 10S3, AND HARDENED CIRCULAR WASHERS, CONFORMING TO AASHTO M293 (ASTM F436) TYPE 3 (WEATHERING) WITH $\frac{1}{16}$ " DIA. HOLES, UNLESS OTHERWISE NOTED.
- SPLICE BOLTS SHALL BE PLACED WITH HEADS ON THE OUTSIDE FACE OF EXTERIOR GIRDERS AND ON BOTTOM OF GIRDER FLANGES.
- BOLT THREADS MUST BE EXCLUDED FROM FIELD SPLICE SHEAR PLANES.
- NO FIELD WELDING TO GIRDERS WILL BE ALLOWED EXCEPT AS SHOWN ON PLANS.
- GIRDERS ARE SHOWN AND DIMENSIONED WITH TOP FLANGE IN THE HORIZONTAL POSITION. VERTICAL CURVATURE AND EFFECTS OF DEAD LOAD DEFLECTION HAVE NOT BEEN TAKEN INTO CONSIDERATION. SHOP DRAWINGS SHALL INCLUDE BLOCKING DIAGRAM FOR EACH GIRDER SHOWING ALL ADJUSTMENTS NECESSARY FOR DEAD LOAD DEFLECTION AND VERTICAL CURVATURE. THE WEB PLATES SHALL BE FABRICATED WITH CAMBER FOR DEAD LOAD DEFLECTION AND VERTICAL CURVATURE.

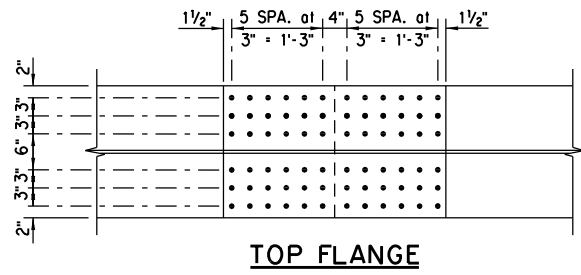

TOP FLANGE

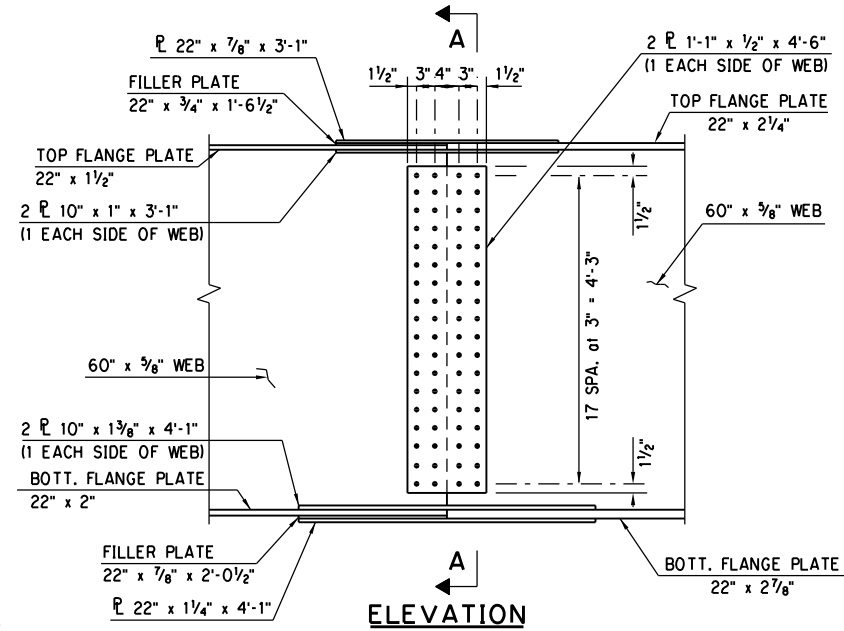

ELEVATION

BOTTOM FLANGE
BOLTED FIELD SPLICE DETAIL
(LEFT SPLICE SHOWN, RIGHT OPPOSITE HAND)

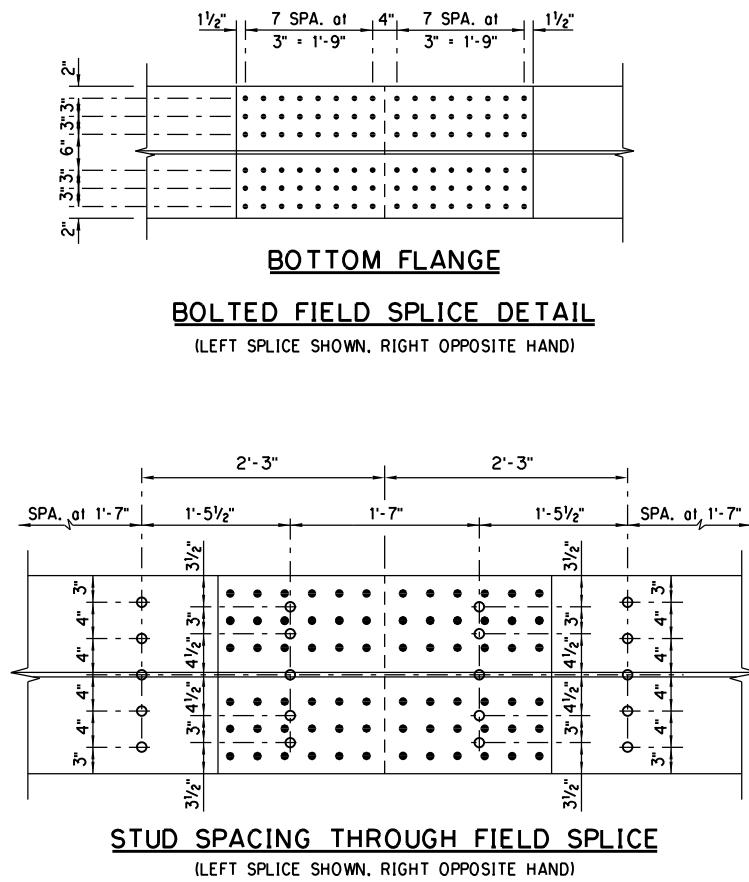

STUD SPACING THROUGH FIELD SPLICE
(LEFT SPLICE SHOWN, RIGHT OPPOSITE HAND)

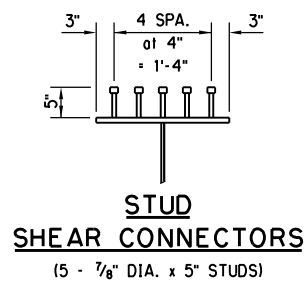

STUD SHEAR CONNECTORS
(5 - $\frac{7}{8}$ " DIA. x 5" STUDS)

DESIGN		PHASE 4	OKLAHOMA COUNTY
DRAWN		BRIDGE "A"	RAMP "A" AT I-35 & I-240 INTERCHANGE
CHECKED		PLATE GIRDER DETAILS	
APPROVED		SPANS 9 AND 10	
SQUAD		(SHEET 2 OF 2)	
POE		STATE JOB NO. 090321081	SHEET NO. B054

3/1/2024 3:21:49 PM H:\PROJECTS\21789_CrossRoads\Phase 4\Bridges\Drawings\Ph4 Bridges\Bridges\A\0903208 P4 Bridge A StGir.dwg

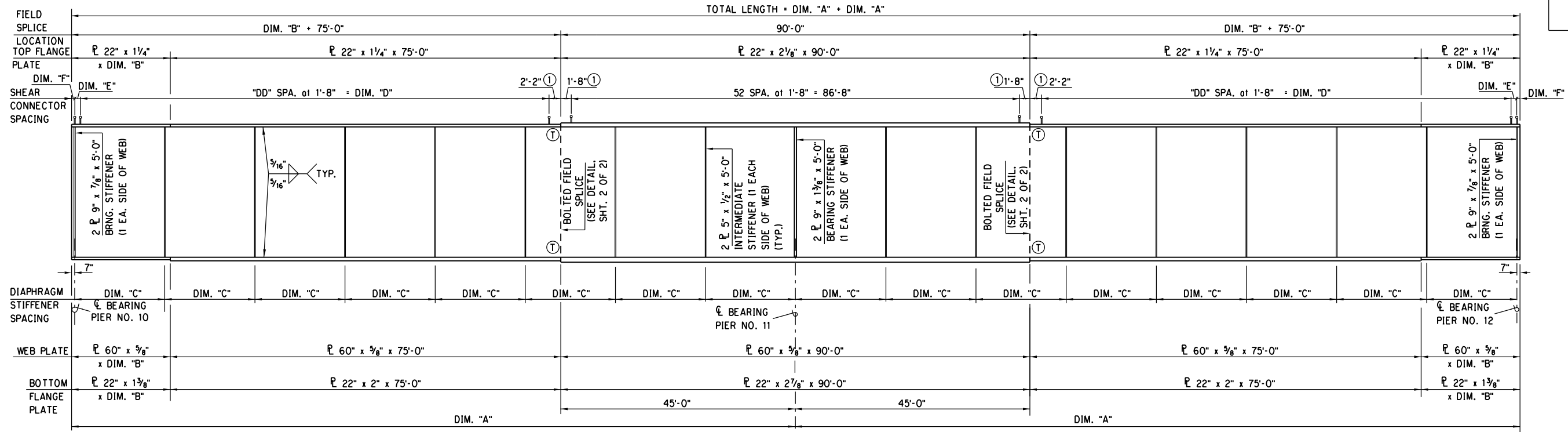
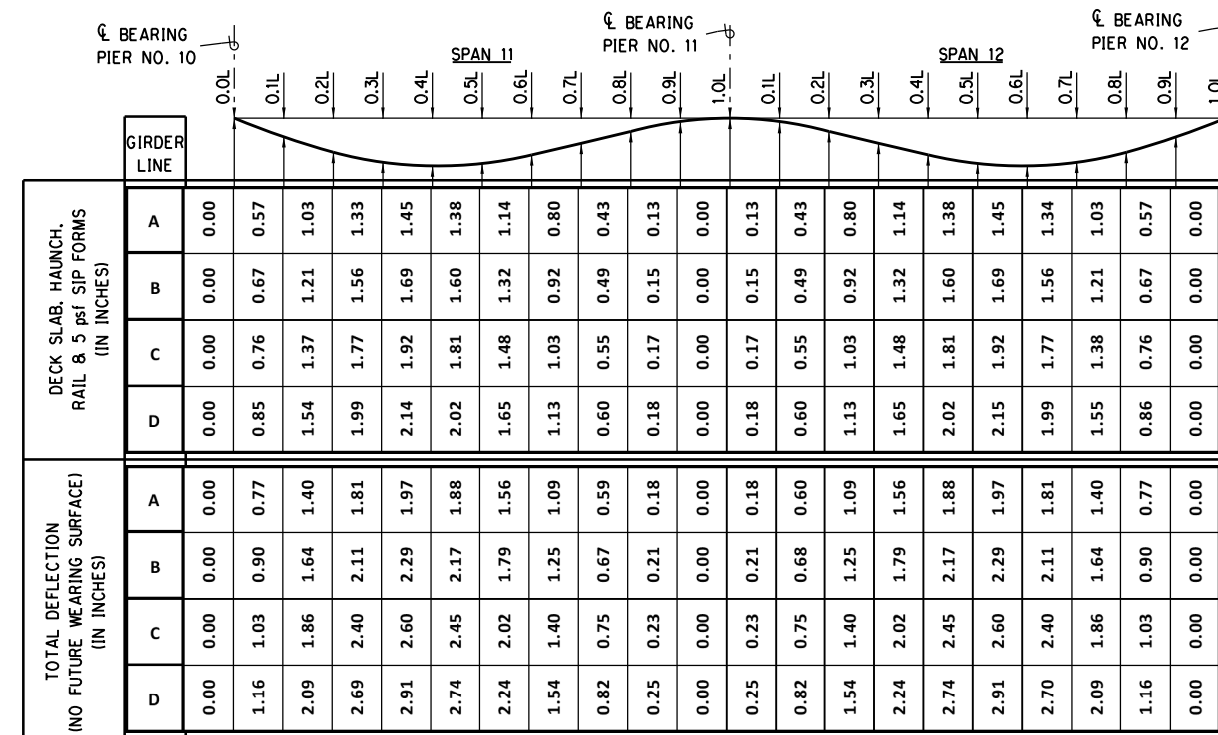

PLATE GIRDER ELEVATION SPANS 11 AND 12

- (T) TENSION SPLICE
- (1) STUD SPACING THROUGH FIELD SPLICE (SEE DETAIL SHEET 2 OF 2)

NOTE: GIRDER DIMENSIONS ARE ALONG CLC ARC OF WEB.

GIRDER	SPAN 11 & 12 GIRDER DIMENSION SCHEDULE								
	TOTAL LENGTH	DIM "A"	DIM "B"	DIM "C"	"DD"	DIM "D"	DIM "E"	DIM "F"	CURVE RADIUS
A	277'-11"	138'-11 1/2"	18'-11 1/2"	17'-3 9/16"	54	90'-0"	1'-2"	7 1/2"	816.26'
B	280'-10"	140'-5"	20'-5"	17'-5 3/4"	55	91'-8"	1'-2"	5"	824.76'
C	283'-9"	141'-10 1/2"	21'-10 1/2"	17'-7 15/16"	56	93'-4"	11"	5 1/2"	833.26'
D	286'-7"	143-3 1/2"	23-3 1/2"	17'-10 1/16"	57	95'-0"	9"	4 1/2"	841.76'



DEAD LOAD DEFLECTION DIAGRAM AND DEFLECTION SCHEDULE

GIRDER	DECK SLAB ELEVATION SCHEDULE AT 10TH POINTS																				
	PIER 10 BRNG.	SPAN 11									PIER 11 BRNG.	SPAN 12									PIER 12 BRNG.
		0.1L	0.2L	0.3L	0.4L	0.5L	0.6L	0.7L	0.8L	0.9L		0.1L	0.2L	0.3L	0.4L	0.5L	0.6L	0.7L	0.8L	0.9L	
A	1317.96	1317.60	1317.22	1316.83	1316.43	1316.01	1315.59	1315.15	1314.71	1314.27	1313.83	1313.39	1312.95	1312.51	1312.07	1311.63	1311.19	1310.75	1310.30	1309.86	1309.42
B	1318.47	1318.11	1317.73	1317.34	1316.94	1316.52	1316.10	1315.66	1315.22	1314.78	1314.34	1313.90	1313.46	1313.02	1312.58	1312.14	1311.70	1311.25	1310.81	1310.37	1309.93
C	1318.98	1318.62	1318.24	1317.85	1317.45	1317.03	1316.61	1316.17	1315.73	1315.29	1314.85	1314.41	1313.97	1313.53	1313.09	1312.65	1312.21	1311.76	1311.32	1310.88	1310.44
D	1319.49	1319.13	1318.75	1318.36	1317.96	1317.54	1317.12	1316.68	1316.24	1315.80	1315.36	1314.92	1314.48	1314.04	1313.60	1313.16	1312.72	1312.27	1311.83	1311.39	1310.95

3/1/2024 3:24:20 PM H:\PROJECTS\2789_CrossRoads_Phase 4\Bridges\Drawings\Phase 4\Bridges\Bridges\Bridges A\0903208 P4 Bridge A S101r-dr.dgn

DESIGN		PHASE 4	OKLAHOMA COUNTY
DRAWN		BRIDGE "A"	RAMP "A" AT I-35 & I-240 INTERCHANGE
CHECKED		<p align="center">PLATE GIRDER DETAILS</p> SPANS 11 AND 12 (SHEET 1 OF 2)	
APPROVED			
SQUAD	POE		
		STATE JOB NO. 09032108	SHEET NO. B055

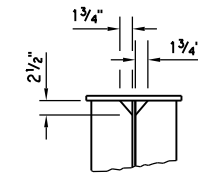

TYP. CORNER CLIP
(ALL STIFFENERS TOP AND BOTTOM)

NOTE: TERMINATE FILLET WELDS 3/8" FROM THE EDGE OF CLIPPED CORNERS OF ALL STIFFENER PLATES AND NON-CLIPPED CORNERS OF INTERMEDIATE DIAPHRAGM STIFFENERS. WRAP FILLET WELDS AROUND NON-CLIPPED CORNERS OF BEARING STIFFENERS.

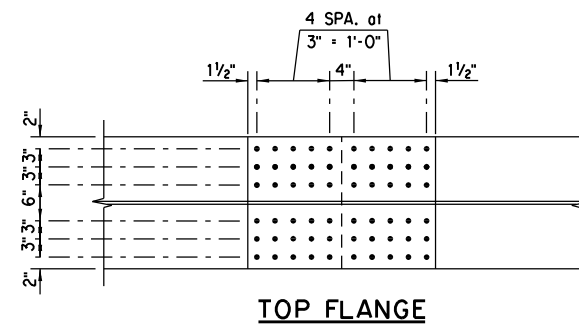

TOP FLANGE

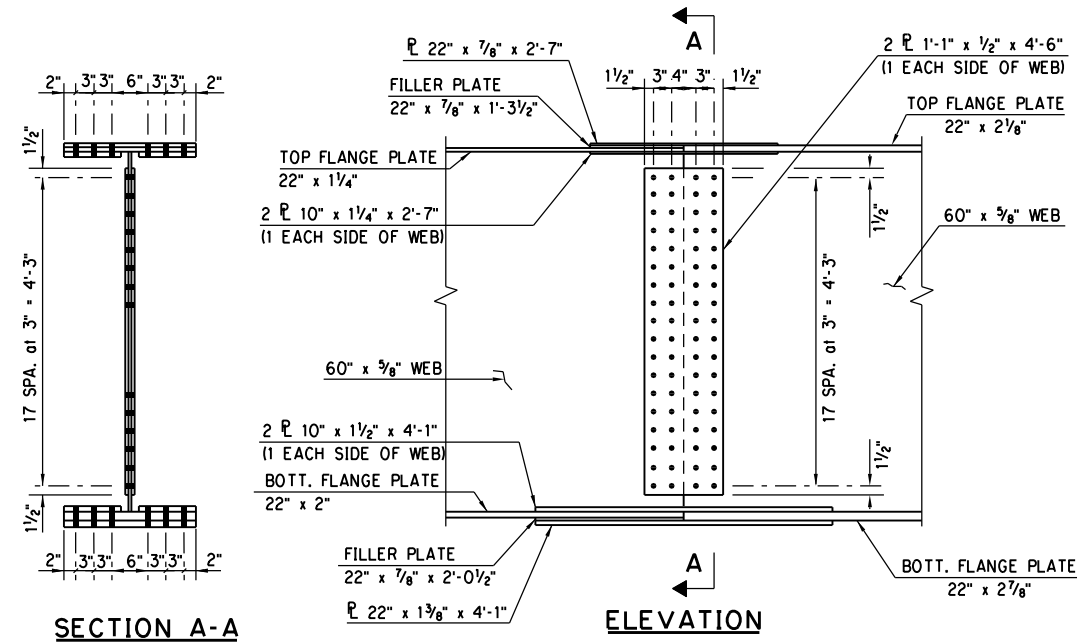

SECTION A-A

ELEVATION

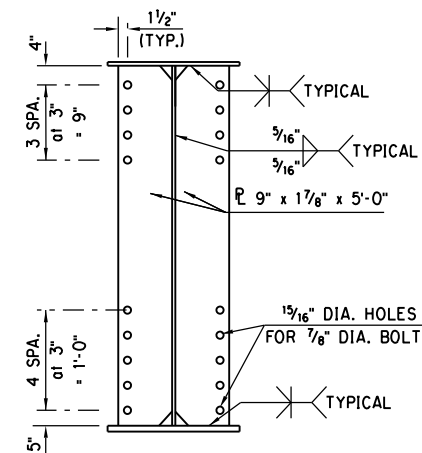

**BEARING STIFFENER
PIERS NO. 10 AND 12**

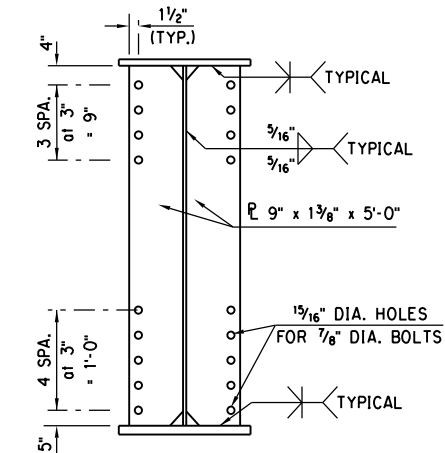

**BEARING STIFFENER
PIER NO. 11**

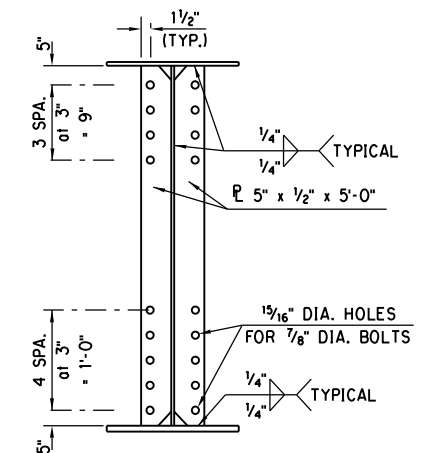

INTERMEDIATE STIFFENER

NOTE: SEE PLATE GIRDER ELEVATION, SHEET 1 OF 2 AND "FRAMING PLAN & DIAPHRAGM DETAILS", SHEET 2 OF 3 FOR LOCATIONS OF STIFFENERS.

OMIT BOLT HOLES ON EXTERIOR STIFFENERS ON EXTERIOR GIRDERS.

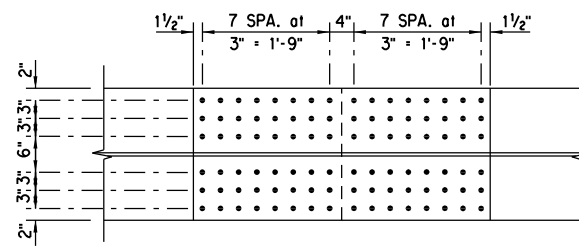

BOTTOM FLANGE

BOLTED FIELD SPLICE DETAIL

(LEFT SPLICE SHOWN, RIGHT OPPOSITE HAND)

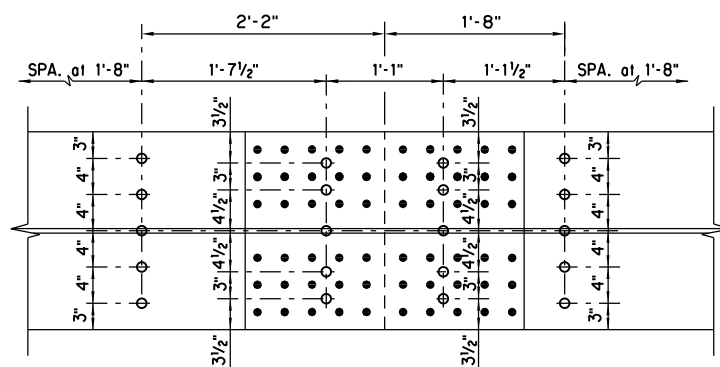

STUD SPACING THROUGH FIELD SPLICE

(LEFT SPLICE SHOWN, RIGHT OPPOSITE HAND)

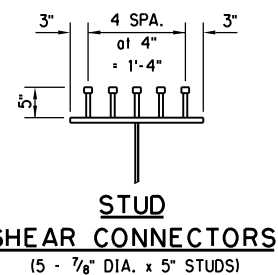

STUD SHEAR CONNECTORS
(5 - 7/8" DIA. x 5" STUDS)

NOTES:

ALL GIRDER, STIFFENER AND SPLICE PLATES SHALL BE AASHTO M270. (ASTM A709) GRADE 50WT2.

ALL GIRDER, STIFFENER AND SPLICE PLATES SHALL CONFORM TO THE NON-FRACTURE CRITICAL CHARTY V-NOTCH TESTED FOR ZONE 2.

USE SHEAR CONNECTORS CONFORMING TO AASHTO M169 (ASTM A108). GRADE 1015, 1018, 1020.

PROVIDE WELDING WITH WEATHERING CHARACTERISTICS.

ALL HIGH STRENGTH BOLTS SHALL BE 7/8" DIA. CONFORMING TO AASHTO M164 (ASTM A325) TYPE 3 (WEATHERING) WITH HEAVY HEX NUTS, CONFORMING TO AASHTO M291 (ASTM A563), PROPERTY CLASS 8S3 OR 10S3, AND HARDENED CIRCULAR WASHERS, CONFORMING TO AASHTO M293 (ASTM F436) TYPE 3 (WEATHERING) WITH 1/16" DIA. HOLES, UNLESS OTHERWISE NOTED.

SPLICE BOLTS SHALL BE PLACED WITH HEADS ON THE OUTSIDE FACE OF EXTERIOR GIRDERS AND ON BOTTOM OF GIRDER FLANGES.

BOLT THREADS MUST BE EXCLUDED FROM FIELD SPLICE SHEAR PLANES.

NO FIELD WELDING TO GIRDERS WILL BE ALLOWED EXCEPT AS SHOWN ON PLANS.

GIRDERS ARE SHOWN AND DIMENSIONED WITH TOP FLANGE IN THE HORIZONTAL POSITION. VERTICAL CURVATURE AND EFFECTS OF DEAD LOAD DEFLECTION HAVE NOT BEEN TAKEN INTO CONSIDERATION. SHOP DRAWINGS SHALL INCLUDE BLOCKING DIAGRAM FOR EACH GIRDER SHOWING ALL ADJUSTMENTS NECESSARY FOR DEAD LOAD DEFLECTION AND VERTICAL CURVATURE. THE WEB PLATES SHALL BE FABRICATED WITH CAMBER FOR DEAD LOAD DEFLECTION AND VERTICAL CURVATURE.

3/1/2024 3:24:26 PM H:\PROJECTS\2789_CrossRoads_Phase 4\Bridges\Drawings\Ph4 Bridges\Bridges\A\0903208 P4 Bridge A StGir-dr.dgn

DESIGN		PHASE 4	OKLAHOMA COUNTY
DRAWN		BRIDGE "A"	RAMP "A" AT I-35 & I-240 INTERCHANGE
CHECKED		PLATE GIRDER DETAILS SPANS 11 AND 12 (SHEET 2 OF 2)	
APPROVED			
SQUAD	POE	STATE JOB NO. 090321081	SHEET NO. B056

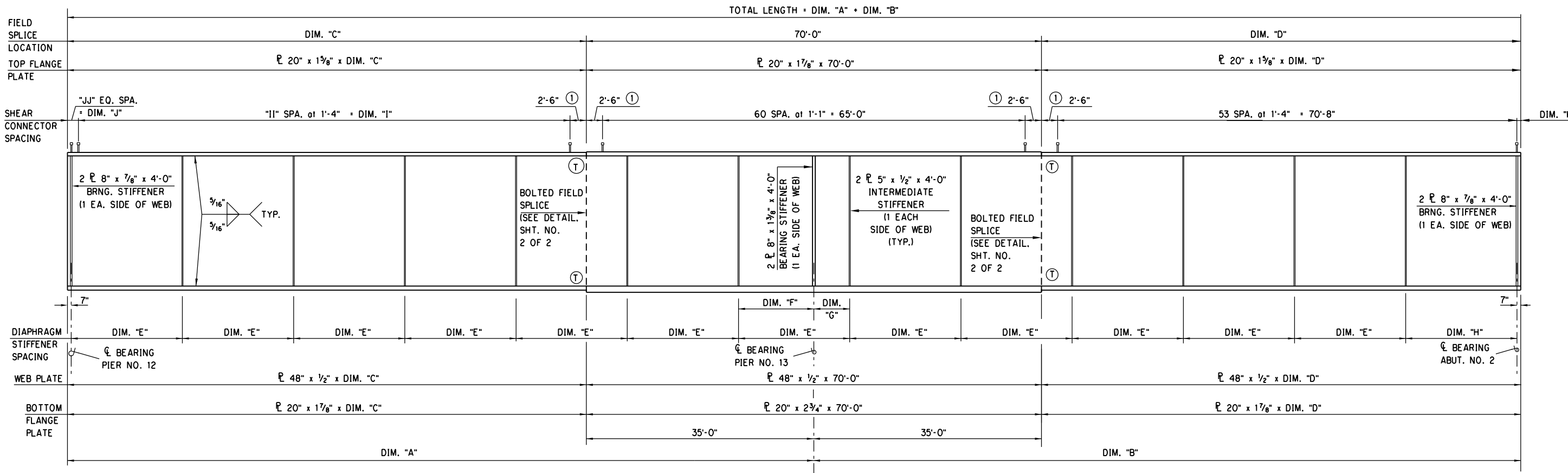
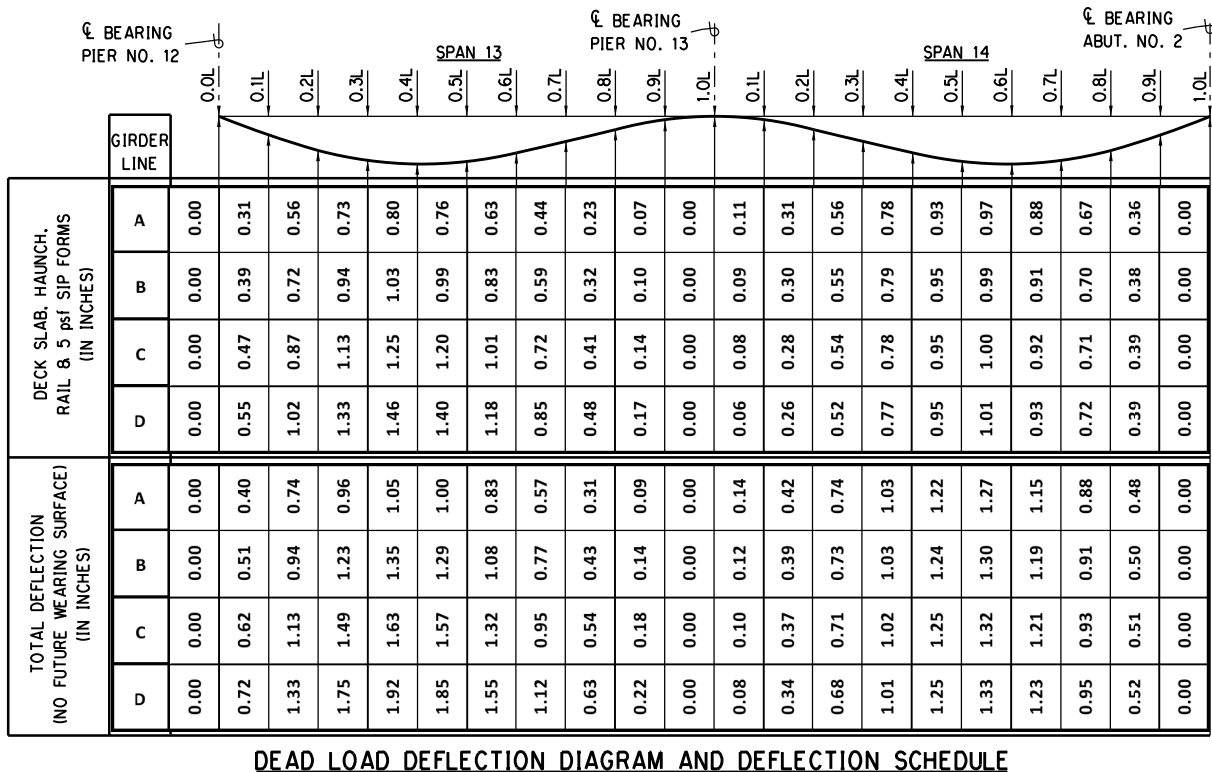

PLATE GIRDER ELEVATION SPANS 13 AND 14

NOTE: GIRDER DIMENSIONS ARE ALONG \bar{C} ARC OF WEB.

- Ⓧ TENSION SPLICE
- ① STUD SPACING THROUGH FIELD SPLICE (SEE DETAIL SHEET 2 OF 2)



DEAD LOAD DEFLECTION DIAGRAM AND DEFLECTION SCHEDULE

GIRDER	SPAN 13 & 14 GIRDER DIMENSION SCHEDULE															CURVE RADIUS
	TOTAL LENGTH	DIM "A"	DIM "B"	DIM "C"	DIM "D"	DIM "E"	DIM "F"	DIM "G"	DIM "H"	"I"	DIM "I"	"J"	DIM "J"	DIM "K"		
A	214'-5 3/8"	105'-7 7/16"	108'-9 15/16"	70'-7 7/16"	73'-9 15/16"	16'-7 1/16"	5'-6 1/16"	11'-1"	14'-2 5/8"	50	66'-8"	3	1'-5 7/16"	7 15/16"	816.26'	
B	217'-5 11/16"	108'-8 3/16"	108'-9 1/2"	73'-8 3/16"	73'-9 1/2"	16'-9 1/8"	7'-6 7/16"	9'-2 11/16"	15'-2 3/16"	53	70'-8"	1	6 3/16"	7 1/2"	824.76'	
C	220'-6"	111'-8 7/8"	108'-9 1/4"	76'-8 7/8"	73'-9 1/4"	16'-11 3/16"	9'-6 3/4"	7'-4 7/16"	16'-1 3/4"	55	73'-4"	2	10 7/8"	7 1/4"	833.26'	
D	223'-6 1/4"	114'-9 5/8"	108'-8 5/8"	79'-9 5/8"	73'-8 5/8"	17'-1 1/4"	11'-7 1/8"	5'-6 1/8"	17'-1 1/4"	57	76'-0"	3	1'-3 5/8"	6 5/8"	841.76'	

GIRDER	DECK SLAB ELEVATION SCHEDULE AT 10TH POINTS																				
	SPAN 13										SPAN 14										
	PIER 12 BRNG.	0.1L	0.2L	0.3L	0.4L	0.5L	0.6L	0.7L	0.8L	0.9L	PIER 13 BRNG.	0.1L	0.2L	0.3L	0.4L	0.5L	0.6L	0.7L	0.8L	0.9L	PIER 14 BRNG.
A	1309.38	1309.04	1308.71	1308.37	1308.04	1307.70	1307.37	1307.04	1306.70	1306.37	1306.03	1305.69	1305.34	1305.00	1304.65	1304.31	1303.96	1303.62	1303.28	1302.93	1302.59
B	1309.89	1309.55	1309.20	1308.86	1308.52	1308.18	1307.84	1307.50	1307.16	1306.82	1306.48	1306.14	1305.80	1305.46	1305.12	1304.78	1304.43	1304.09	1303.75	1303.41	1303.07
C	1310.40	1310.05	1309.70	1309.36	1309.01	1308.66	1308.32	1307.97	1307.62	1307.28	1306.93	1306.59	1306.25	1305.92	1305.58	1305.24	1304.90	1304.57	1304.23	1303.89	1303.56
D	1310.91	1310.55	1310.20	1309.85	1309.50	1309.14	1308.79	1308.44	1308.09	1307.73	1307.38	1307.05	1306.71	1306.38	1306.04	1305.71	1305.38	1305.04	1304.71	1304.37	1304.04

DESIGN		PHASE 4	OKLAHOMA COUNTY
DRAWN		BRIDGE "A"	RAMP "A" AT I-35 & I-240 INTERCHANGE
CHECKED		PLATE GIRDER DETAILS SPANS 13 AND 14 (SHEET 1 OF 2)	
APPROVED			
SQUAD	POE	STATE JOB NO. 09032(08)	SHEET NO. B057

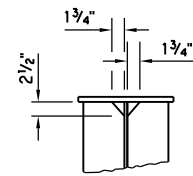

TYP. CORNER CLIP
(ALL STIFFENERS TOP AND BOTTOM)

NOTE: TERMINATE FILLET WELDS $\frac{3}{8}$ " FROM THE EDGE OF CLIPPED CORNERS OF ALL STIFFENER PLATES AND NON-CLIPPED CORNERS OF INTERMEDIATE DIAPHRAGM STIFFENERS. WRAP FILLET WELDS AROUND NON-CLIPPED CORNERS OF BEARING STIFFENERS.

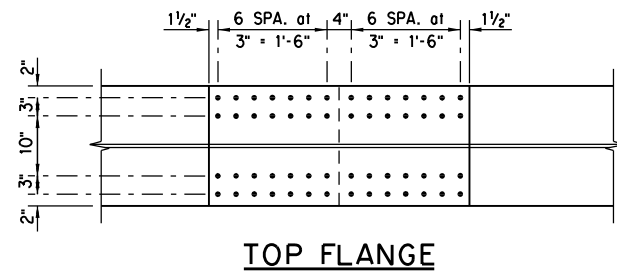

TOP FLANGE

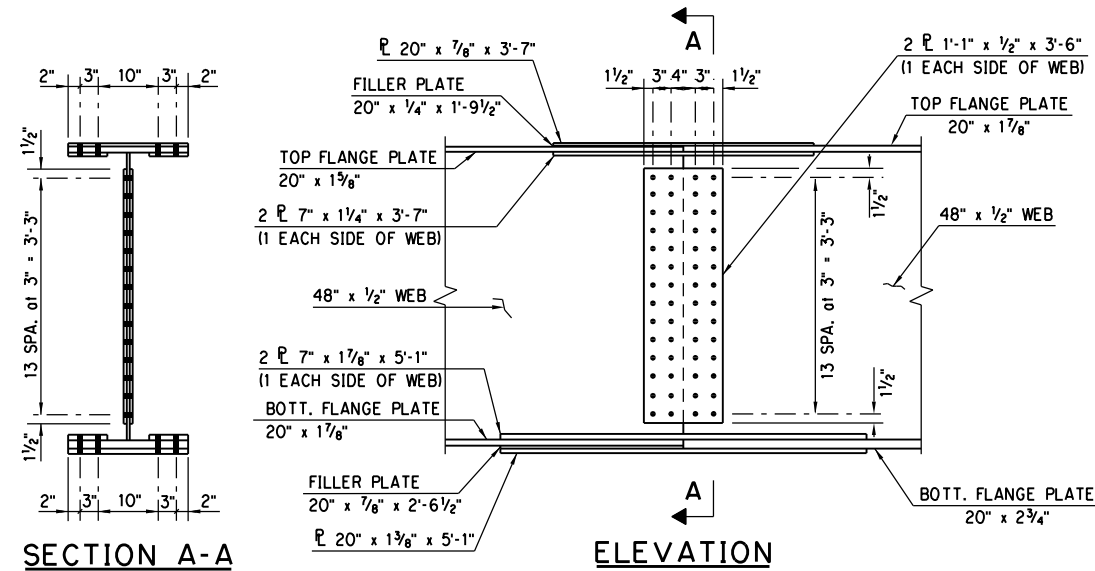

ELEVATION

SECTION A-A

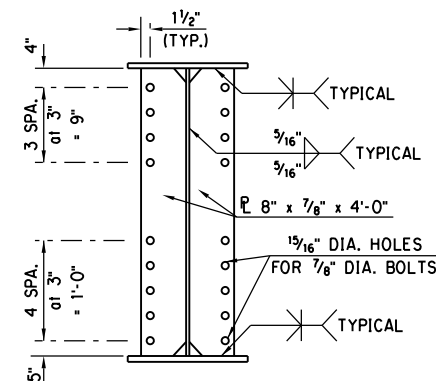

**BEARING STIFFENER
PIERS NO. 12 AND ABUT. NO. 2**

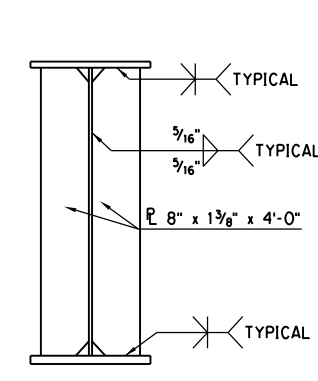

**BEARING STIFFENER
PIER NO. 13**

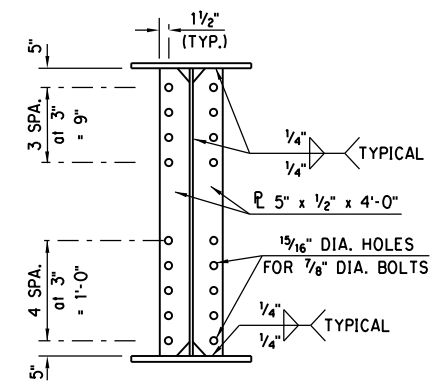

INTERMEDIATE STIFFENER

NOTE: SEE PLATE GIRDER ELEVATION, SHEET 1 OF 2 AND "FRAMING PLAN & DIAPHRAGM DETAILS", SHEET 3 OF 3 FOR LOCATIONS OF STIFFENERS.

OMIT BOLT HOLES ON EXTERIOR STIFFENERS ON EXTERIOR GIRDERS.

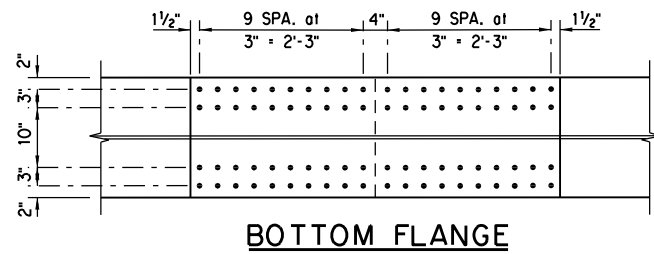

BOTTOM FLANGE

BOLTED FIELD SPLICE DETAIL
(LEFT SPLICE SHOWN, RIGHT OPPOSITE HAND)

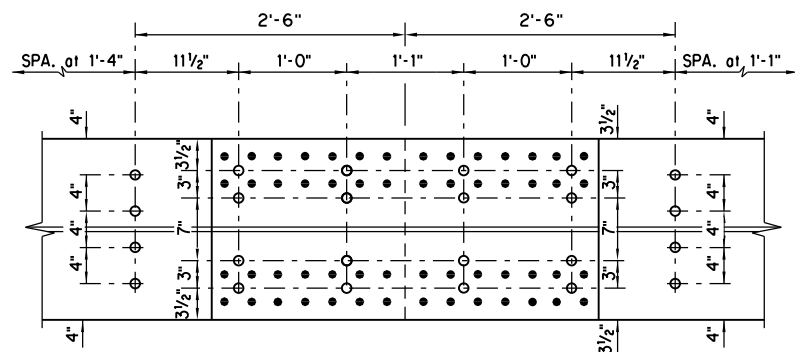

STUD SPACING THROUGH FIELD SPLICE
(LEFT SPLICE SHOWN, RIGHT OPPOSITE HAND)

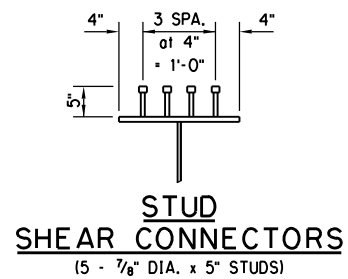

**STUD
SHEAR CONNECTORS**
(5 - $\frac{7}{8}$ " DIA. x 5" STUDS)

NOTES:

ALL GIRDER, STIFFENER AND SPLICE PLATES SHALL BE AASHTO M270, (ASTM A709) GRADE 50WT2.

ALL GIRDER, STIFFENER AND SPLICE PLATES SHALL CONFORM TO THE NON-FRACTURE CRITICAL CHARPY V-NOTCH TESTED FOR ZONE 2.

USE SHEAR CONNECTORS CONFORMING TO AASHTO M169 (ASTM A108), GRADE 1015, 1018, 1020.

PROVIDE WELDING WITH WEATHERING CHARACTERISTICS.

ALL BOLTS SHALL BE $\frac{7}{8}$ " DIA. ASTM A325 TYPE 3 WITH HEAVY HEX NUTS, HARDENED CIRCULAR WASHERS, AND $\frac{15}{16}$ " DIA. HOLES, UNLESS OTHERWISE NOTED.

SPLICE BOLTS SHALL BE PLACED WITH HEADS ON THE OUTSIDE FACE OF EXTERIOR GIRDERS AND ON BOTTOM OF GIRDER FLANGES.

BOLT THREADS MUST BE EXCLUDED FROM FIELD SPLICE SHEAR PLANES.

NO FIELD WELDING TO GIRDERS WILL BE ALLOWED EXCEPT AS SHOWN ON PLANS.

DESIGN		PHASE 4	OKLAHOMA COUNTY
DRAWN		BRIDGE "A"	RAMP "A" AT I-35 & I-240 INTERCHANGE
CHECKED		PLATE GIRDER DETAILS SPANS 13 AND 14 (SHEET 2 OF 2)	
APPROVED			
SQUAD	POE	STATE JOB NO. 090321081	SHEET NO. B058

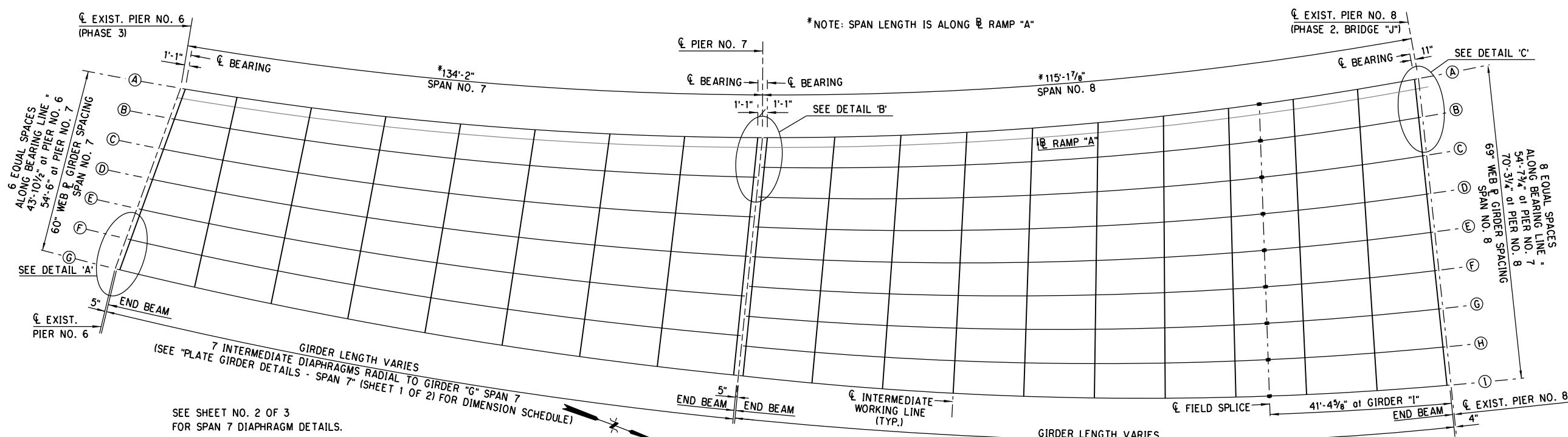

SEE SHEET NO. 2 OF 3
FOR SPAN 7 DIAPHRAGM DETAILS.

SEE "PLATE GIRDER DETAILS - SPAN 8" (SHEET 1 OF 2) FOR DIMENSION SCHEDULE

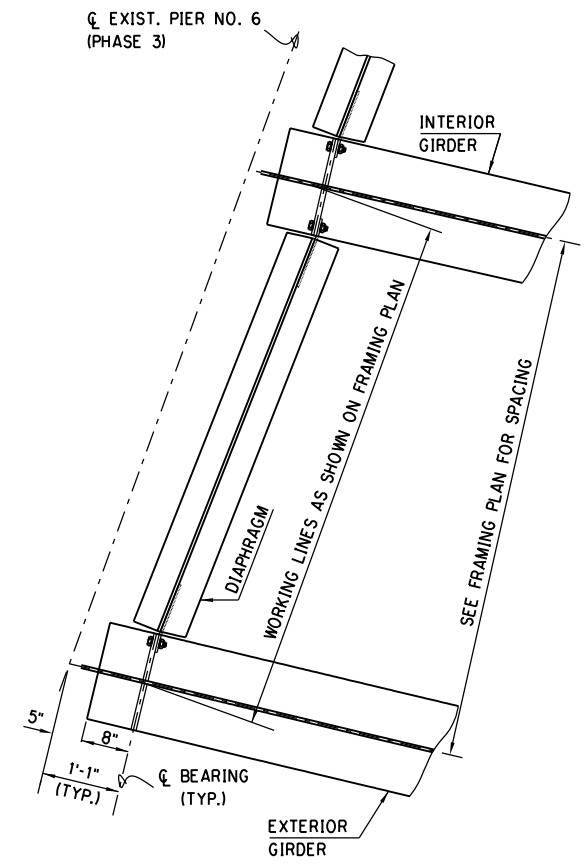

DETAIL 'A'
DETAIL AT PIER NO. 6

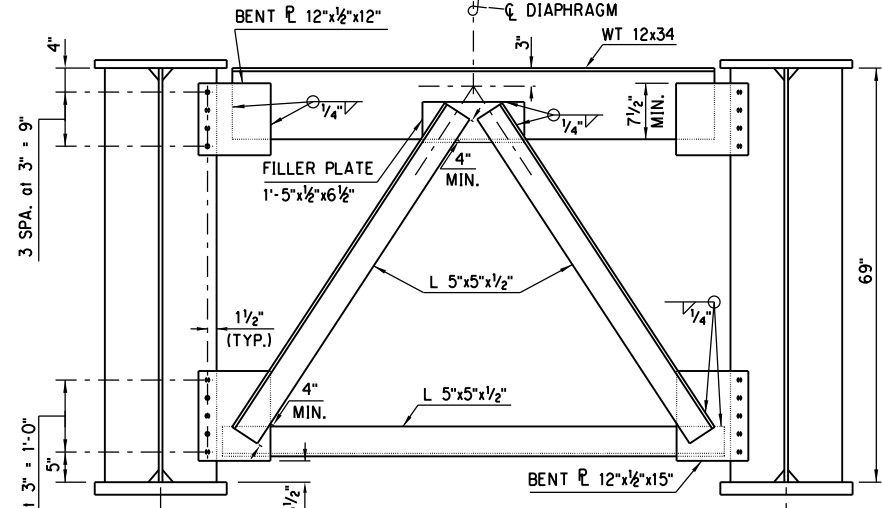

SPAN NO. 8 END DIAPHRAGMS
(PIERS NO. 7 AND 8)
(M270 GRADE 50W STEEL)

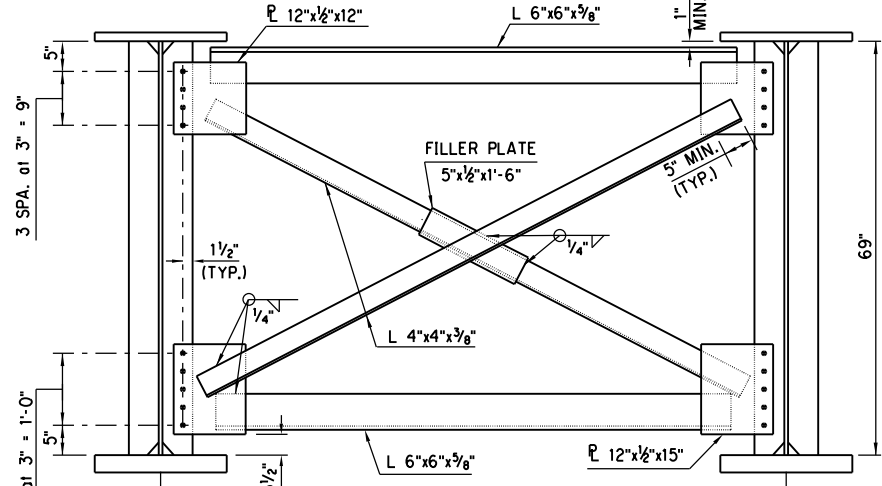

SPAN NO. 8 INTERMEDIATE DIAPHRAGMS
(M270 GRADE 50W STEEL)

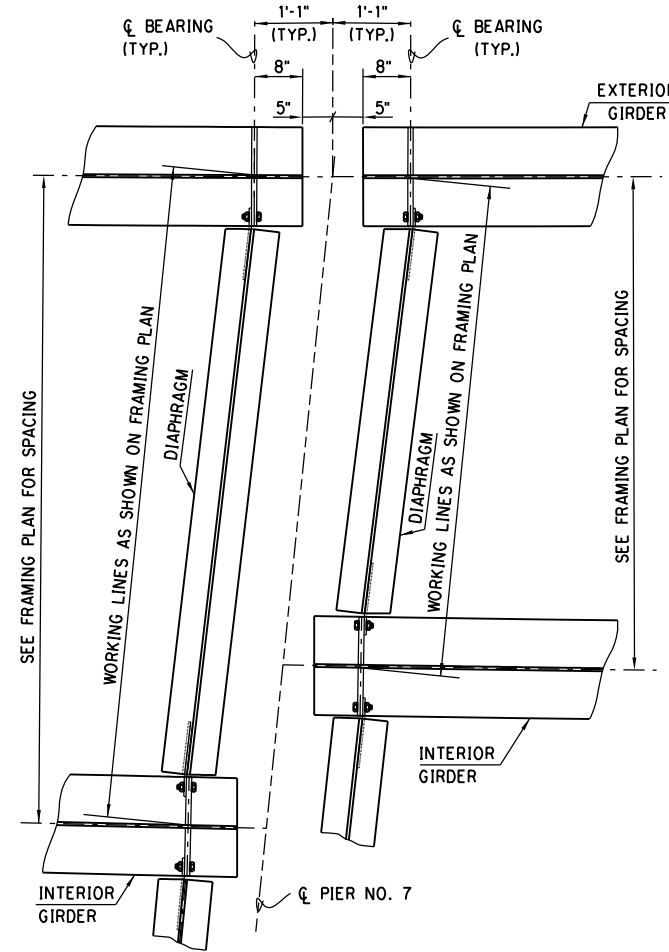

DETAIL 'B'
DETAIL AT PIER NO. 7

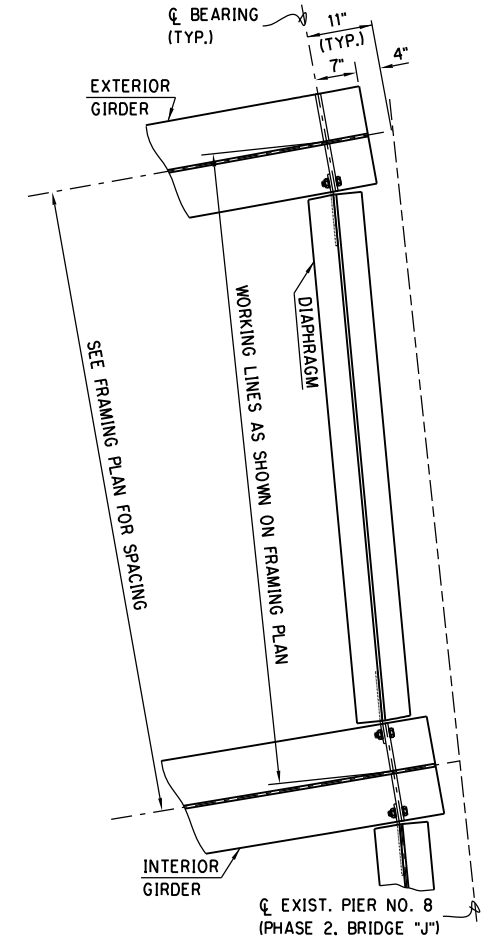

DETAIL 'C'
DETAIL AT PIER NO. 8

DESIGN		PHASE 4	OKLAHOMA COUNTY
DRAWN		BRIDGE "A"	RAMP "A" AT I-35 & I-240 INTERCHANGE
CHECKED		FRAMING PLAN AND DIAPHRAGM DETAILS (SHEET 1 OF 3)	
APPROVED			
SQUAD	POE		
		STATE JOB NO. 09032108 SHEET NO. B059	

3/1/2024 3:21:37 PM H:\PROJECTS\2789_CrossRoads_Phase 4\Bridges\Drawings\Ph4 Bridges\Bridges\A\0903208 P4 Bridge A StiffDiaphragm.dgn

* NOTE: SPAN LENGTH IS ALONG RAMP "A"

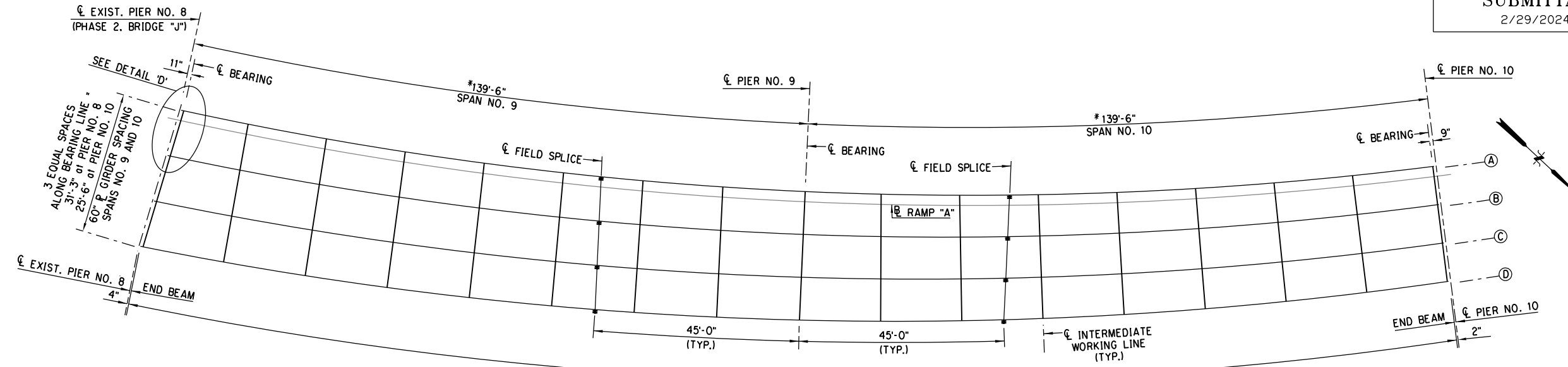

GIRDER LENGTH VARIES
15 INTERMEDIATE DIAPHRAGMS RADIAL TO GIRDER "D" SPANS 9 & 10
(SEE "PLATE GIRDER DETAILS - SPANS 9 & 10" (SHEET 1 OF 2) FOR DIMENSION SCHEDULE)

FRAMING PLAN
SPANS 9 AND 10

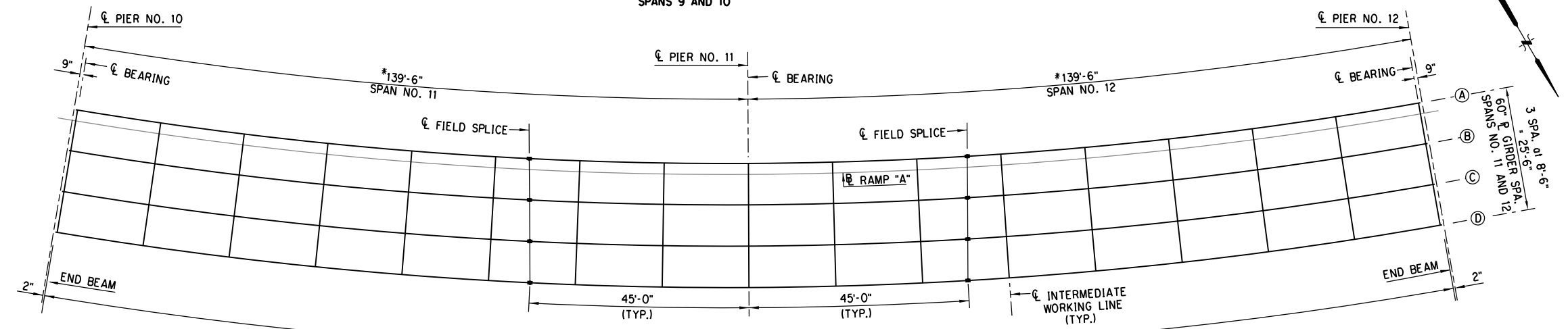

GIRDER LENGTH VARIES
15 INTERMEDIATE DIAPHRAGMS RADIAL TO GIRDER "D" SPANS 11 & 12
(SEE "PLATE GIRDER DETAILS - SPANS 11 & 12" (SHEET 1 OF 2) FOR DIMENSION SCHEDULE)

FRAMING PLAN
SPANS 11 AND 12

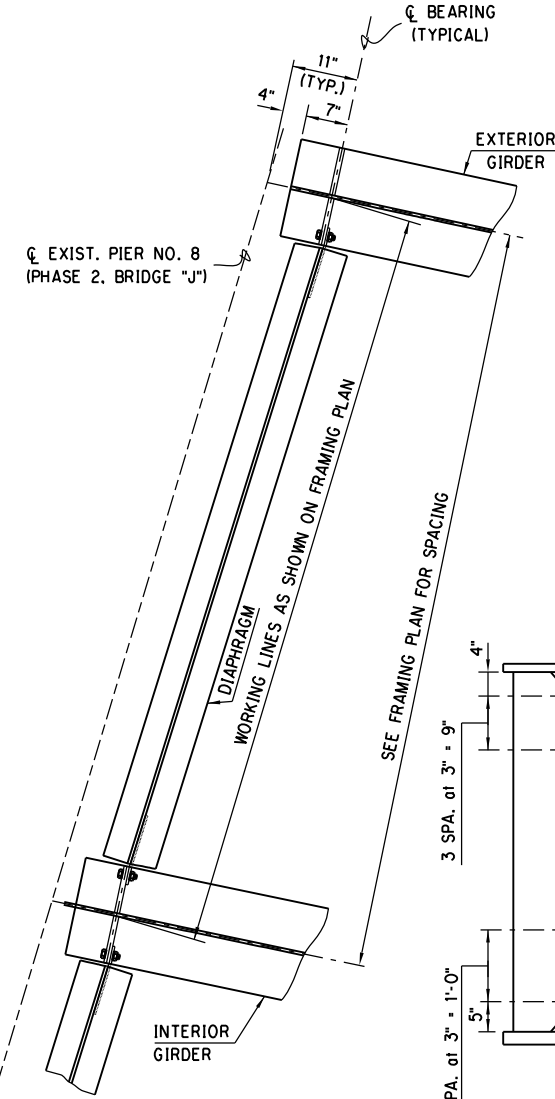

DETAIL 'D'
DETAIL AT PIER NO. 8

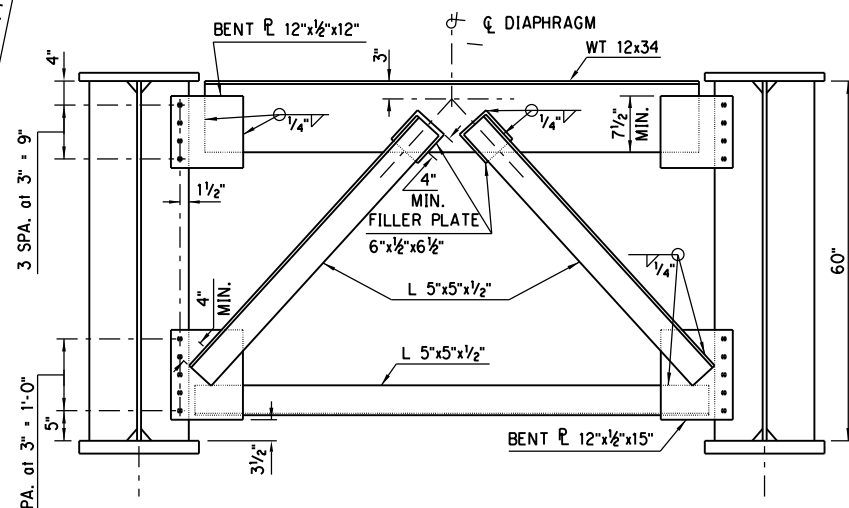

SPANS NO. 7 AND 9 THRU 12 END DIAPHRAGMS
(PIERS NO. 6, 7, 8, 10 AND 12)
(M270 GRADE 50W STEEL)

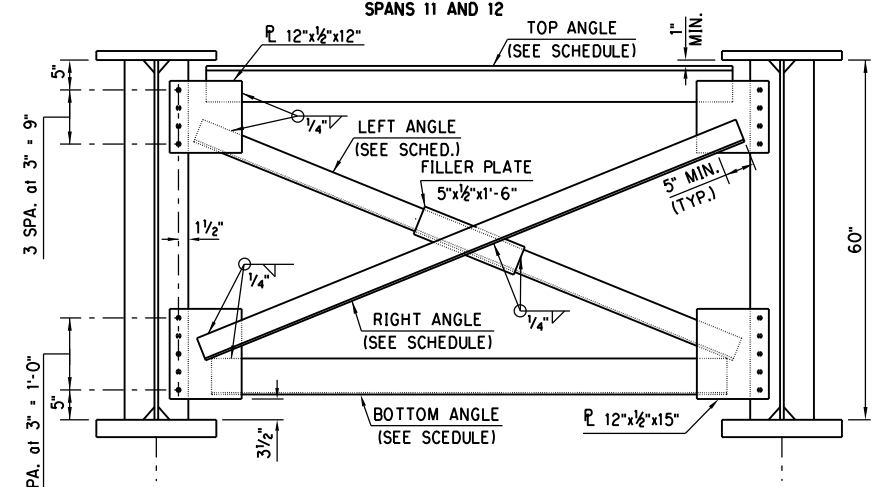

SPANS NO. 7 AND 9 THRU 12 INTERMEDIATE DIAPHRAGMS
(INCL. PIERS NO. 9 AND 11)
(M270 GRADE 50W STEEL)

INTERMEDIATE DIAPHRAGM ANGLE SCHEDULE				
SPAN	ANGLE			
	TOP	BOTTOM	LEFT	RIGHT
7	6" x 6" x 1/2"	6" x 6" x 1/2"	4" x 4" x 3/8"	4" x 4" x 3/8"
9-10	6" x 6" x 5/8"	6" x 6" x 5/8"	4" x 4" x 5/8"	4" x 4" x 5/8"
11-12	6" x 6" x 1/2"	6" x 6" x 1/2"	4" x 4" x 3/8"	4" x 4" x 3/8"

DESIGN	
DRAWN	
CHECKED	
APPROVED	
SQUAD	POE

PHASE 4
BRIDGE "A" RAMP "A" AT I-35 & I-240 INTERCHANGE
OKLAHOMA COUNTY

**FRAMING PLAN AND
DIAPHRAGM DETAILS**
(SHEET 2 OF 3)

STATE JOB NO. 09032108 SHEET NO. B06Q

3/1/2024 3:21:39 PM H:\PROJECTS\2789_CrossRoads_Phase 4\Bridges\Drawings\Bridges\Phase 4\0903208 P4 Bridge A StFRmDiaph.dgn

* NOTE: SPAN LENGTH IS ALONG RAMP "A"

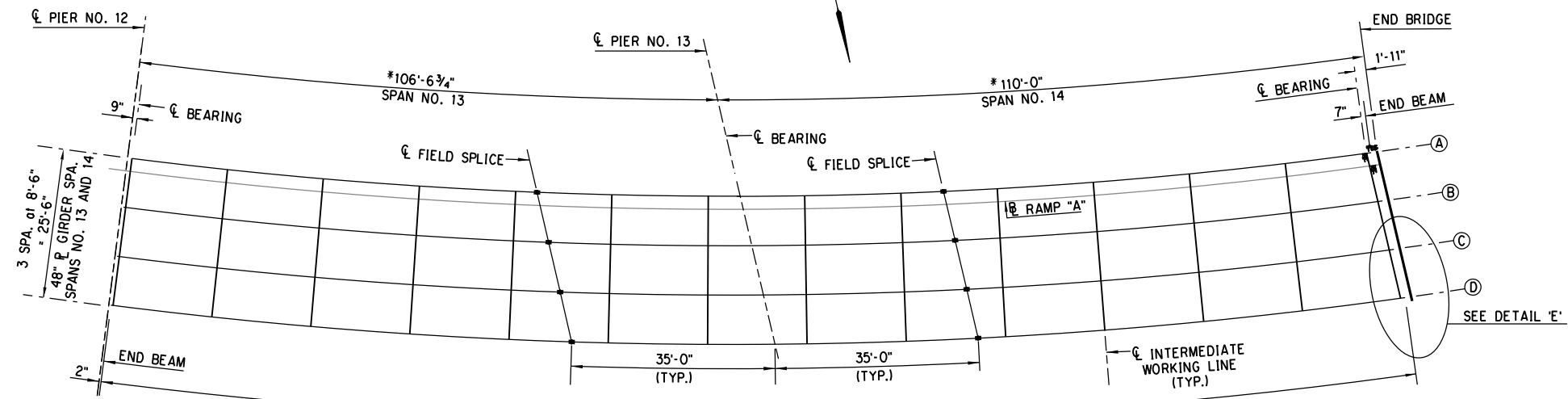

GIRDER LENGTH VARIES
12 INTERMEDIATE DIAPHRAGMS RADIAL TO GIRDER "D" SPANS 13 & 14
(SEE "PLATE GIRDER DETAILS - SPANS 13 & 14" (SHEET 1 OF 2) FOR DIMENSION SCHEDULE)

FRAMING PLAN
SPANS 13 AND 14

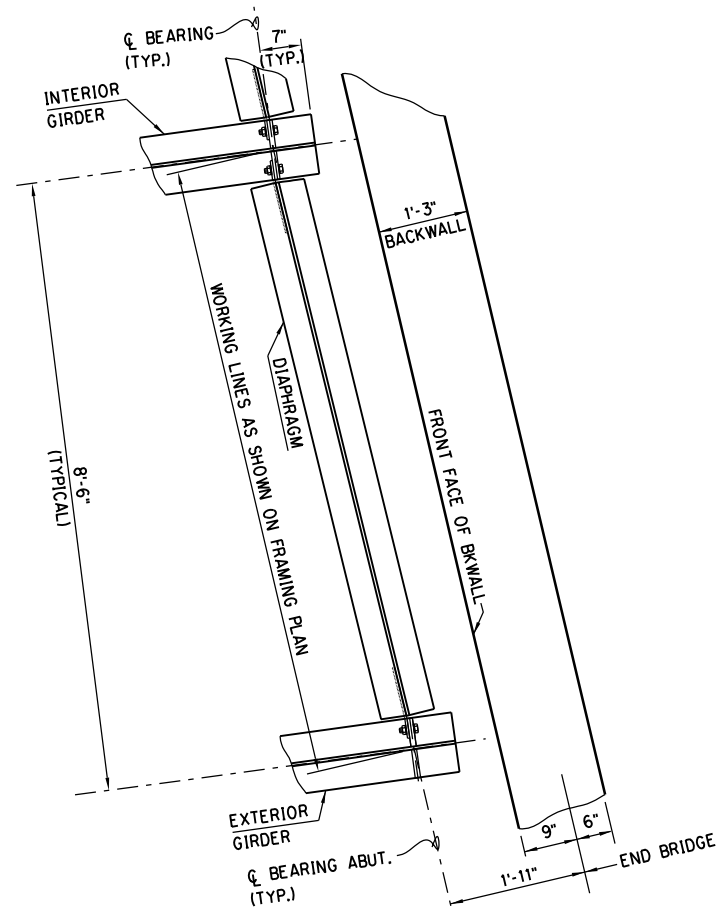

DETAIL 'E'
DETAIL AT ABUTMENT

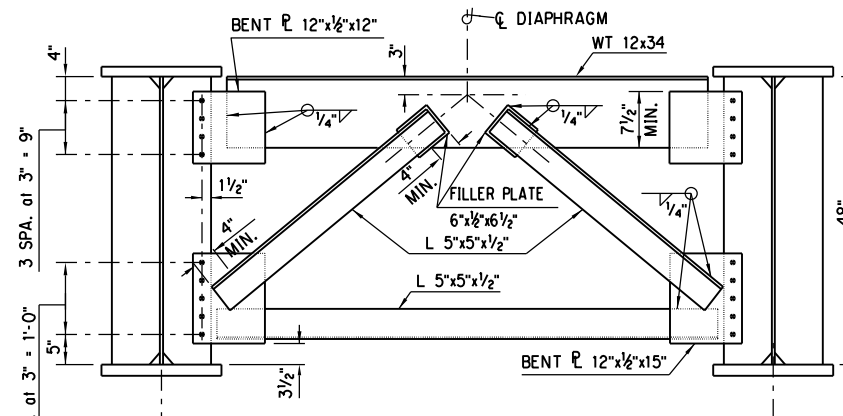

SPANS NO. 13 AND 14 END DIAPHRAGMS

(PIER NO. 12 AND ABUTMENT)
(M270 GRADE 50W STEEL)

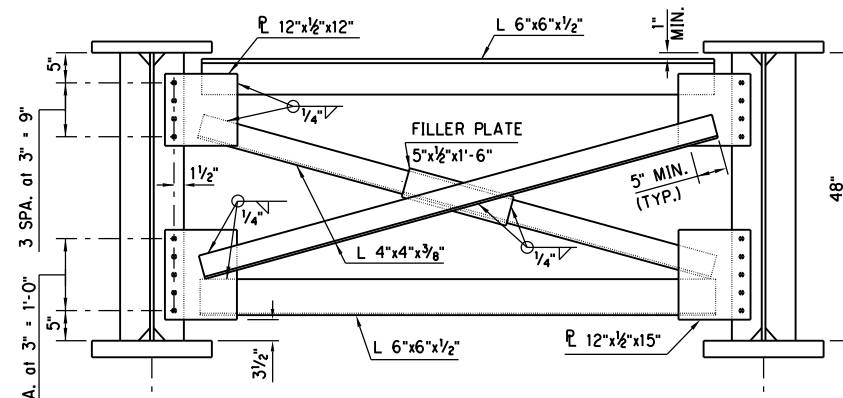

SPANS NO. 13 AND 14 INTERMEDIATE DIAPHRAGMS

(M270 GRADE 50W STEEL)

DESIGN		PHASE 4	OKLAHOMA COUNTY
DRAWN		BRIDGE "A"	RAMP "A" AT I-35 & I-240 INTERCHANGE
CHECKED		<p>FRAMING PLAN AND DIAPHRAGM DETAILS (SHEET 3 OF 3)</p>	
APPROVED			
SQUAD	POE		

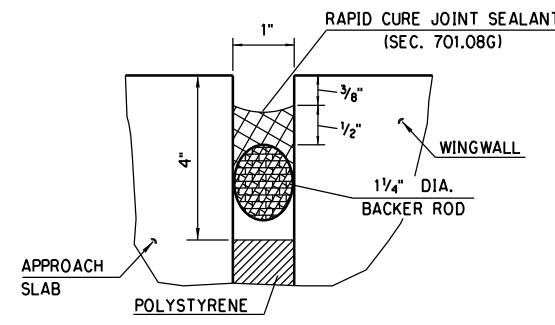
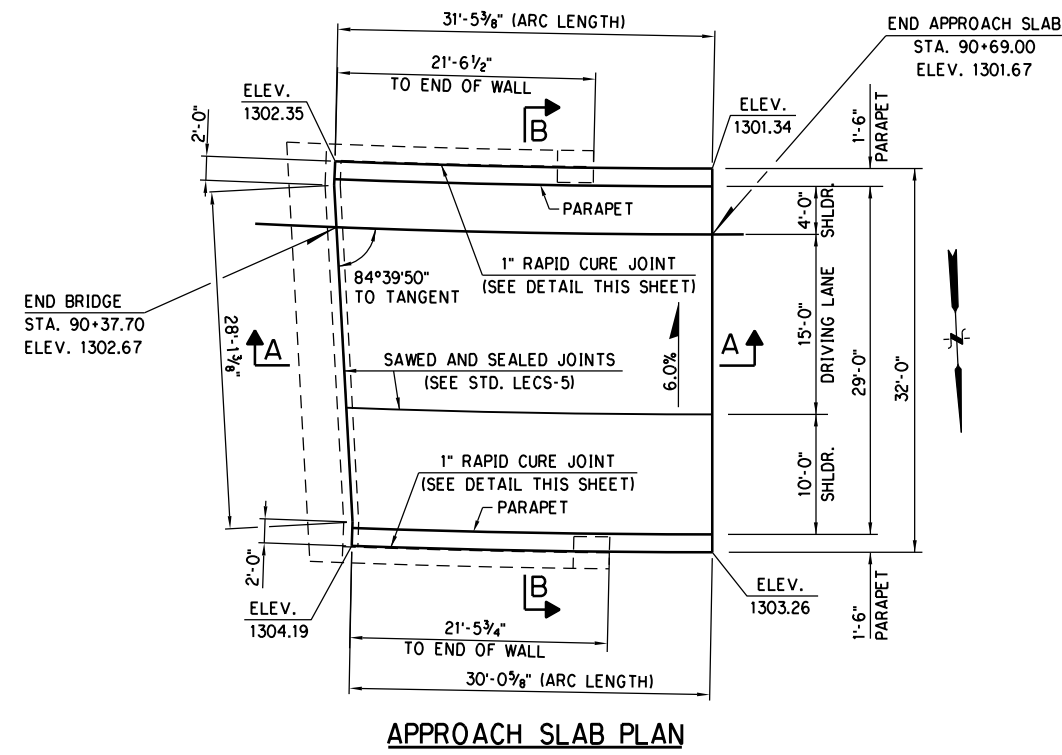

DETAIL OF RAPID CURE JOINT AT WINGWALLS

NOTE: FOR BACKER ROD AND JOINT SEALER GENERAL NOTES REFER TO STD. LECS-5.

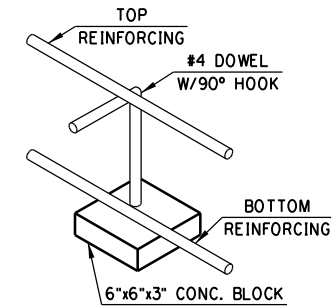

DOWEL BLOCK

NOTE: CONTRACTOR MAY USE APPROVED HIGH CHAIRS WITH SAND PLATES (HCPI) AND 6\"/>

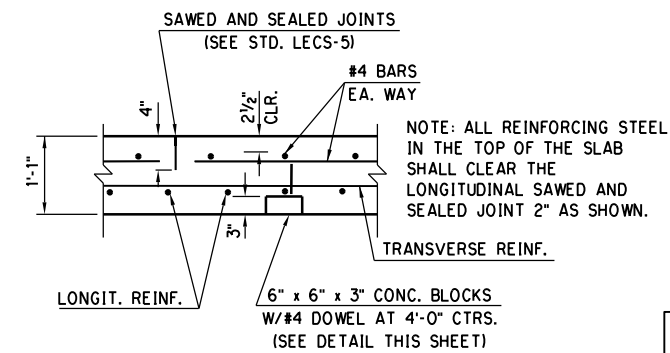

DETAIL OF SAWED JOINT AND DOWEL BLOCK

NOTE: DO NOT TIE WITHIN 6\"/>

NOTE: FOR DETAILS OF PARAPET SEE ODOT STD. FSHP-42-2

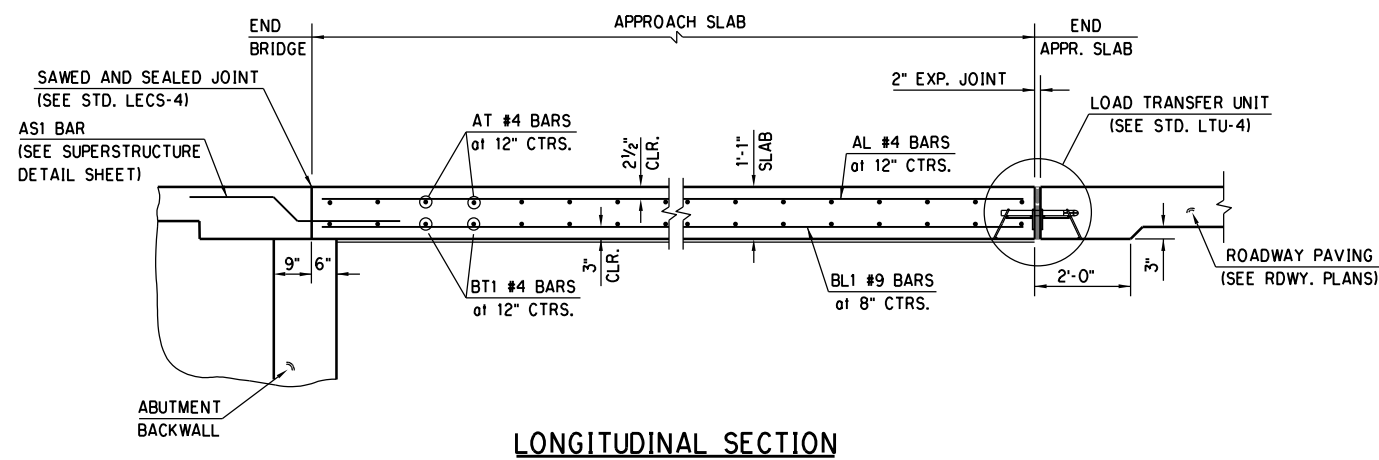

LONGITUDINAL SECTION SECTION A - A

QUANTITIES		
ITEM	UNIT	ABUT. 1
APPROACH SLAB	S.Y.	109.40
SAW-CUT GROOVING	S.Y.	100.00
42\"/>		

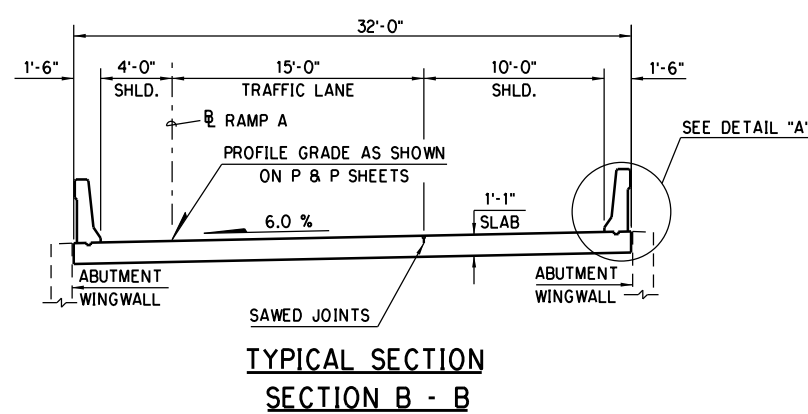

TYPICAL SECTION SECTION B - B

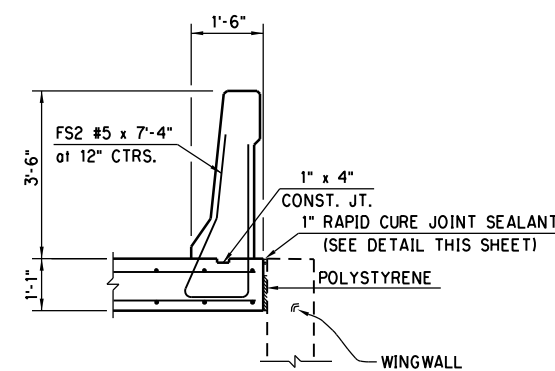

DETAIL "A"

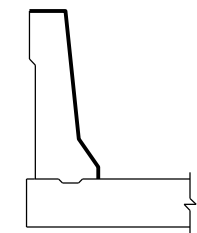

WATER REPELLENT SURFACE TREATMENT
SURFACES INDICATED WITH HEAVY LINES SHALL BE TREATED WITH A PENETRATING WATER REPELLENT SURFACE TREATMENT.

NOTES:
CONCRETE FOR APPROACH SLABS SHALL BE CLASS AA. REINFORCING STEEL SHALL BE GRADE 60.
ALL COST OF MATERIALS, LABOR, AND INCIDENTALS NECESSARY TO COMPLETE THE WORK AS SHOWN SHALL BE INCLUDED IN THE UNIT PRICE BID PER SQUARE YARD OF APPROACH SLAB. THIS PRICE BID SHALL INCLUDE THE COST OF LOAD TRANSFER UNIT, POLYSTYRENE, RAPID CURE JOINT SEALANT, BACKER RODS, SAWING, DOWEL BLOCKS, POLYETHYLENE SHEETING, CLASS AA CONCRETE AND EPOXY COATED REINFORCING STEEL (INCLUDING FS2 PARAPET BARS).
ALL COST OF PARAPET SHALL BE INCLUDED IN PRICE BID PER L.F. OF "42\"/>

DESIGN		PHASE 4	OKLAHOMA COUNTY
DRAWN		BRIDGE "A"	RAMP "A" AT I-35 & I-240 INTERCHANGE
CHECKED		APPROACH SLAB DETAILS (SHEET 1 OF 2)	
APPROVED			
SQUAD	POE		
		STATE JOB NO. 090321081	SHEET NO. B06.3

3/1/2024 3:21:45 PM H:\PROJECTS\2789_CrossRoads_Phase 4 Bridge\Drawings\Ph4 Bridges\Bridges\Bridges\A\0903208 P4 Bridge A Approach.dgn

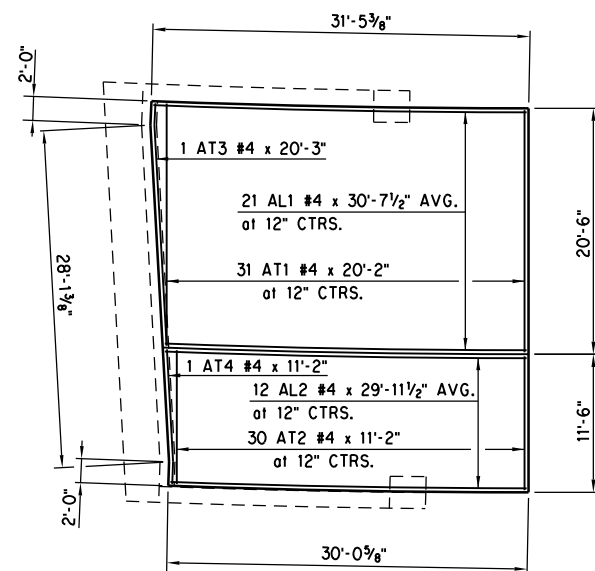

TOP MAT REINFORCING PLAN

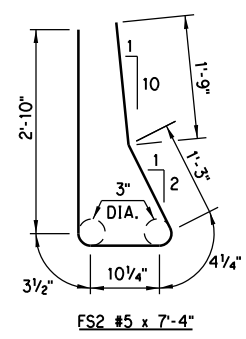

NOTE: FS2 BARS SHALL BE TIED IN PLACE BEFORE POURING THE CONCRETE FOR THE APPROACH SLAB.

NOTE: ALL BENT BAR DIMENSIONS ARE OUT TO OUT.

BAR LIST - EPOXY COATED (FOR INFORMATION ONLY)						
MARK	NO.	SIZE	FORM	SPACING	LENGTH	VARIABLE LENGTH
AL1	21	#4	STR.	12" C/C	30'-7 1/2" AVG.	31'-1" TO 30'-2"
AL2	12	#4	STR.	12" C/C	29'-11 1/2" AVG.	30'-2" TO 29'-9"
AT1	31	#4	STR.	12" C/C	20'-2"	--
AT2	30	#4	STR.	12" C/C	11'-2"	--
AT3	1	#4	STR.	AS SHOWN	20'-3"	--
AT4	1	#4	STR.	AS SHOWN	11'-2"	--
BL1	48	#9	STR.	8" C/C	30'-5" AVG.	31'-1" TO 29'-9"
BT1	30	#4	STR.	12" C/C	31'-8"	--
BT2	1	#4	STR.	AS SHOWN	20'-3"	--
BT3	1	#4	BNT.	AS SHOWN	31'-9"	--
FS2	63	#5	BNT.	12 C/C	7'-4"	--

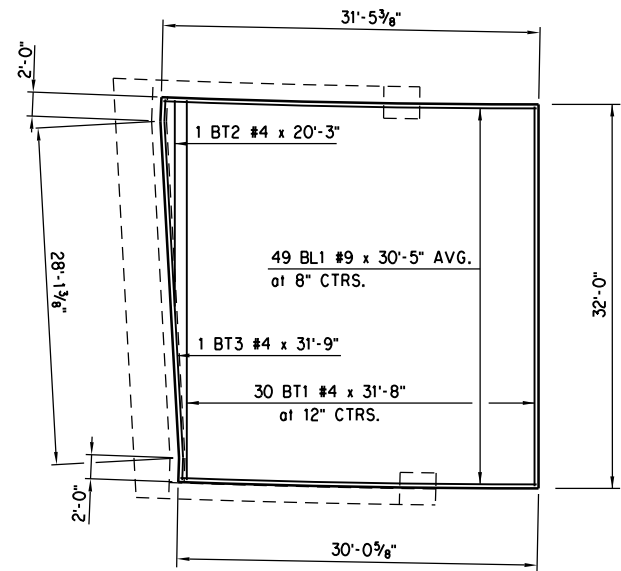

BOTTOM MAT REINFORCING PLAN

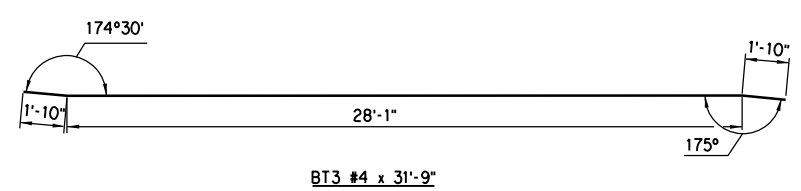
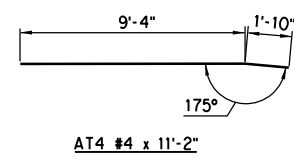
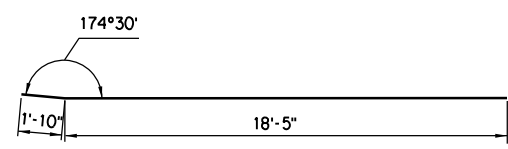

3/1/2024 3:24:47 PM H:\PROJECTS\2789_CrossRoads_Phase 4\Bridges\Drawings\Ph4 Bridges\Bridges\A\0903208 P4 Bridge A Approach.dgn

DESIGN		PHASE 4	OKLAHOMA COUNTY
DRAWN		BRIDGE "A"	RAMP "A" AT I-35 & I-240 INTERCHANGE
CHECKED		<p>APPROACH SLAB DETAILS (SHEET 2 OF 2)</p> <p>STATE JOB NO. <u>09032108</u> SHEET NO. <u>B064</u></p>	
APPROVED			
SQUAD	POE		

QUANTITIES		
ITEM	UNIT	ABUT. 1
SLOPE WALL (5")	S.Y.	272.00
6" PERFORATED PIPE UNDERDRAIN ROUND	L.F.	41.00
① 6" NON-PERF. PIPE UNDERDRAIN RND.	L.F.	20.00

NON-PERFORATED PIPE SHALL BE CONNECTED TO PREFORATED PIPE AND EXTENDED OUTSIDE THE GROUND LINE TO DRAIN, AS DIRECTED IN THE FIELD BY THE ENGINEER.
PLACE A RODENT SCREEN AT OUTLET END OF PIPE.

SLOPE WALL NOTES:

- ALL CONCRETE IN THE SLOPE WALL SHALL BE CLASS A CONCRETE AND SHALL BE POURED IN THE DRY. ALL CONSTRUCTION SHALL BE IN ACCORDANCE WITH SECTIONS 509 AND 610 OF THE STANDARD SPECIFICATIONS.
- NO HORIZONTAL CONSTRUCTION JOINTS WILL BE PERMITTED IN THE SLOPE WALL. FINAL NUMBER AND LOCATION OF VERTICAL CONSTRUCTION JOINTS WILL BE DETERMINED IN THE FIELD BY THE ENGINEER.
- SURFACE AREA OF TOE AND EDGES OF SLOPE WALL INCLUDED IN PAY QUANTITY SHOWN.
- ALL COSTS OF THE JOINT SEALER AND FILLER, REINFORCING STEEL, CONCRETE, EXCAVATION, FILTER SAND COARSE UNDERDRAIN COVER MATERIAL, LABOR, FORMS AND INCIDENTALS NECESSARY TO COMPLETE THE WORK AS SHOWN, SHALL BE INCLUDED IN THE CONTRACT PRICE BID OFR SLOPE WALL (5").

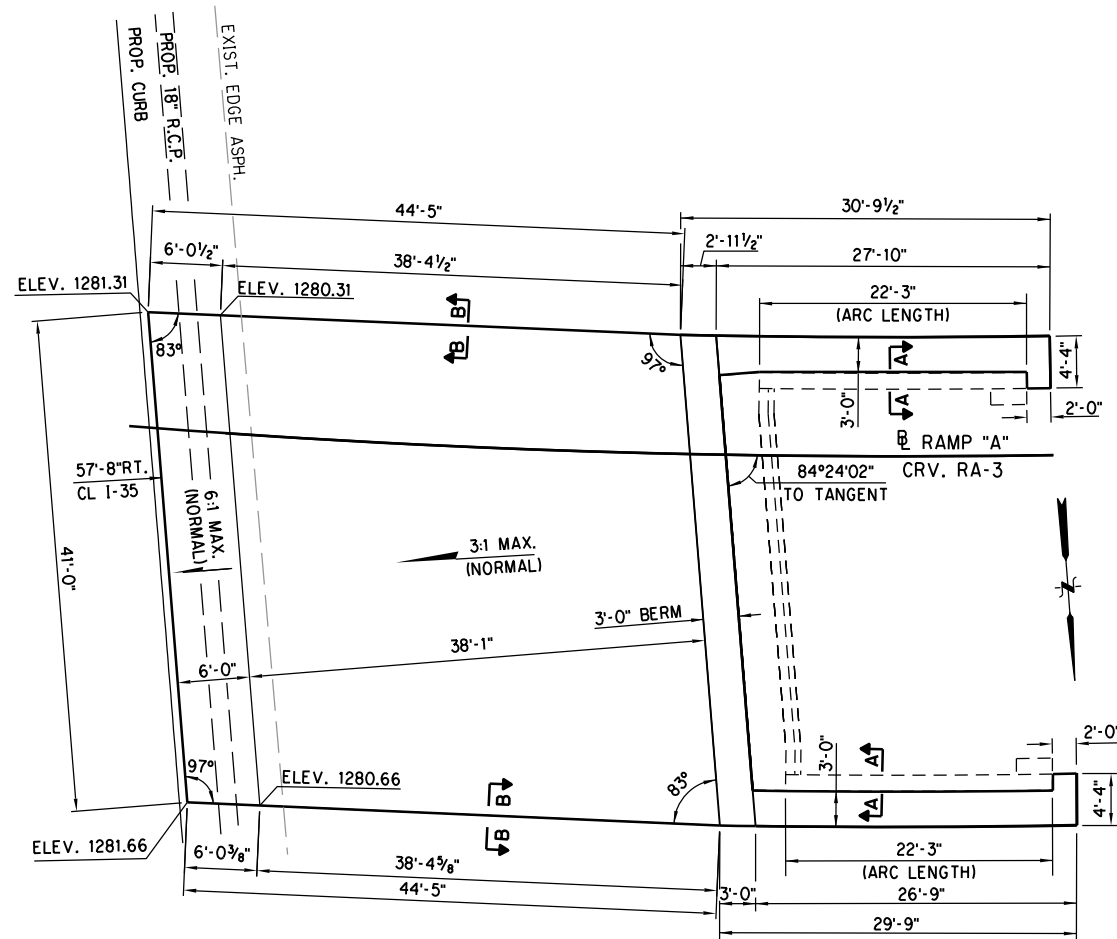

PLAN ABUTMENT NO. 2

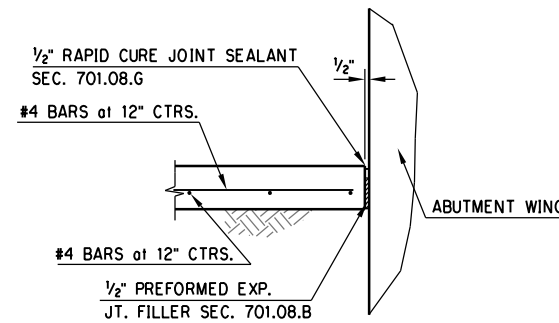

SECTION A-A
(TYPICAL AT WINGWALLS)

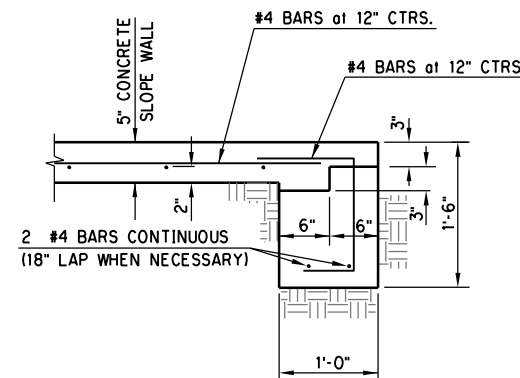

SECTION B-B
(TYPICAL)

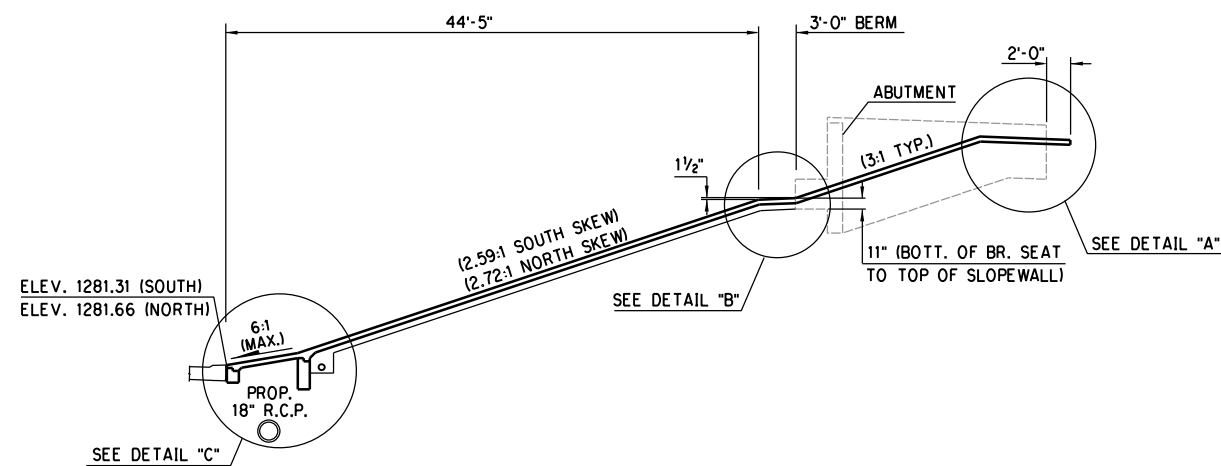

TYPICAL SECTION AT ABUTMENT NO. 2

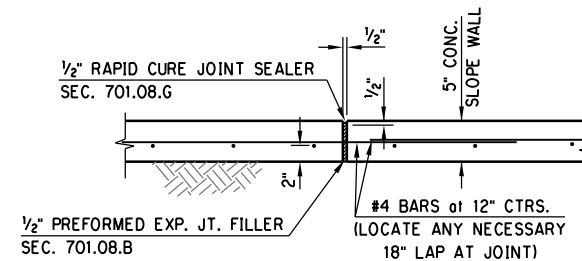

VERTICAL CONSTRUCTION JOINT DETAIL

NOTE: FOR DETAILS A, B, AND C. SEE SHEET 2 OF 2.

3/1/2024 3:24:50 PM H:\PROJECTS\2789_CrossRoads_Phase 4\Bridges\Drawings\Ph4 Bridges\Bridges A\0903208 P4 Bridge A SlopeDets.dgn

DESIGN		PHASE 4	OKLAHOMA COUNTY
DRAWN		BRIDGE "A"	RAMP "A" AT I-35 & I-240 INTERCHANGE
CHECKED		SLOPE WALL DETAILS (SHEET 1 OF 2)	
APPROVED			
SQUAD	POE	STATE JOB NO. 09032(08)	SHEET NO. B065

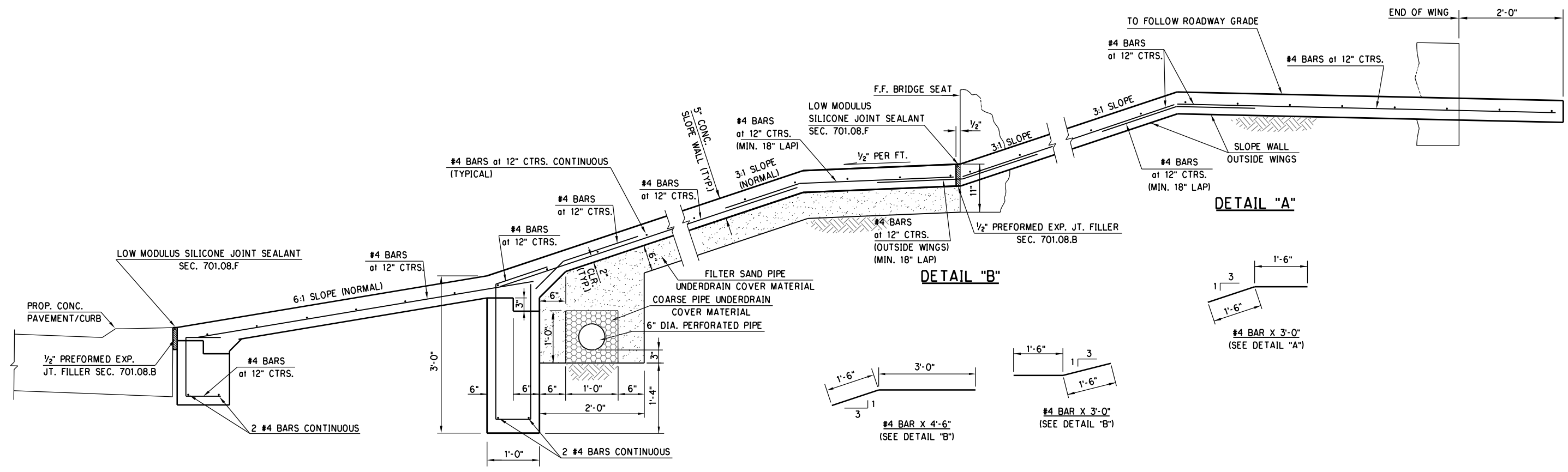

DETAIL "A"

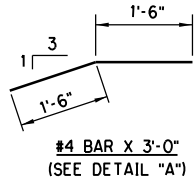

DETAIL "B"

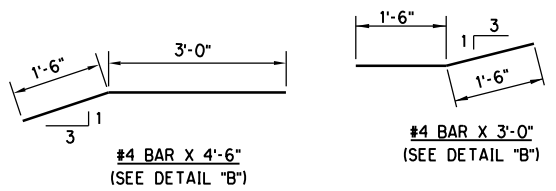

DETAIL "C"

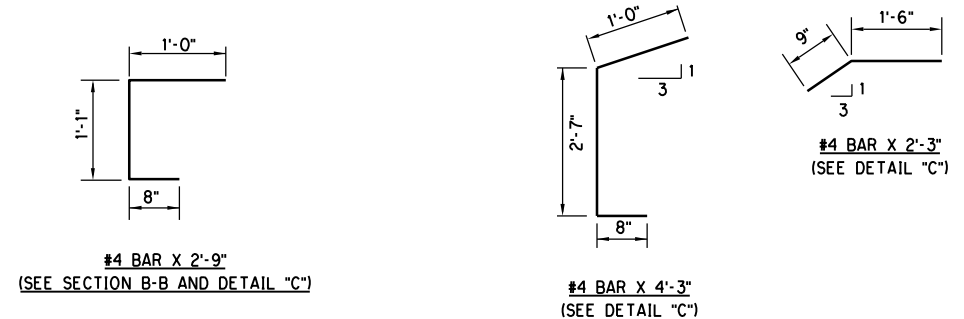

NOTE: ALL BAR BEND DIMENSIONS ARE OUT TO OUT.

3/1/2024 3:24:51 PM H:\PROJECTS\2789_CrossRoads_Phase 4\Bridges\Drawings\Phase 4\Bridges\Bridges\A\0903208 P4 Bridge A SlopeDets.dgn

DESIGN		PHASE 4		OKLAHOMA COUNTY	
DRAWN		BRIDGE "A"		RAMP "A" AT I-35 & I-240 INTERCHANGE	
CHECKED		SLOPE WALL DETAILS (SHEET 2 OF 2)			
APPROVED					
SQUAD					
POE		STATE JOB NO. 090321081 SHEET NO. B066			

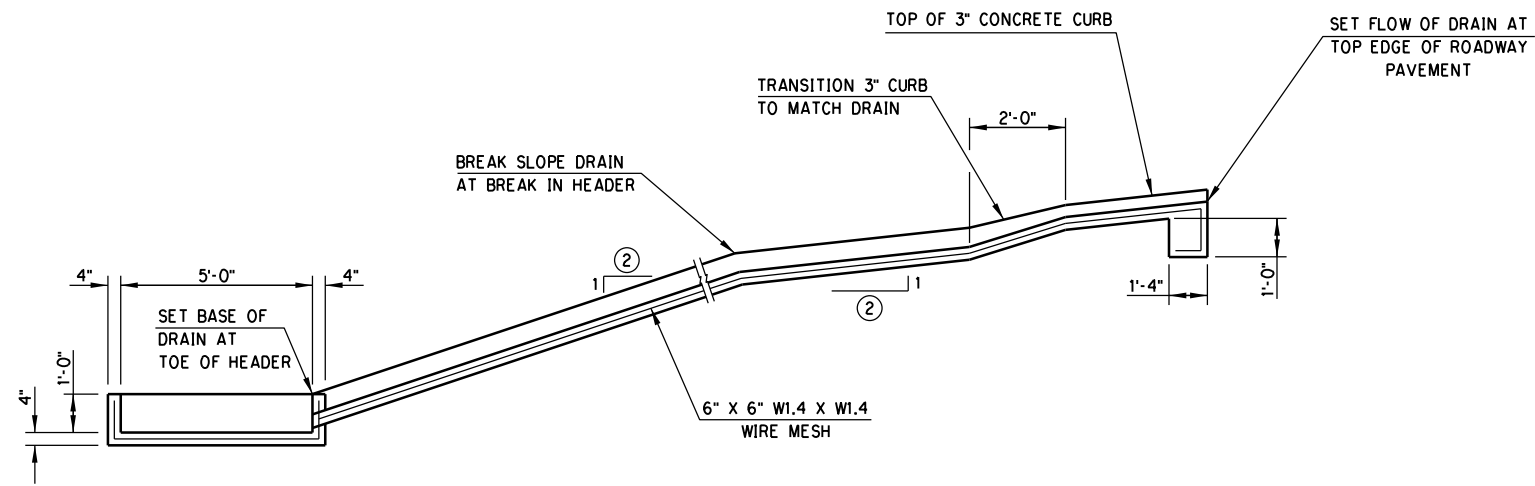

SECTION B-B
② SLOPE TO MATCH SLOPE OF HEADER

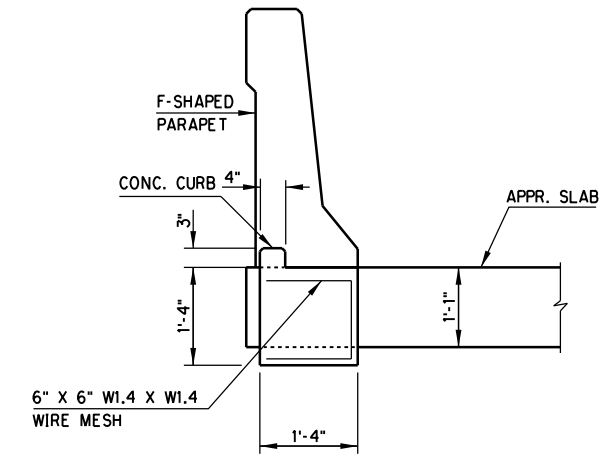

SECTION A-A

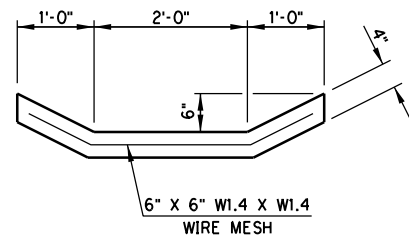

SECTION C-C

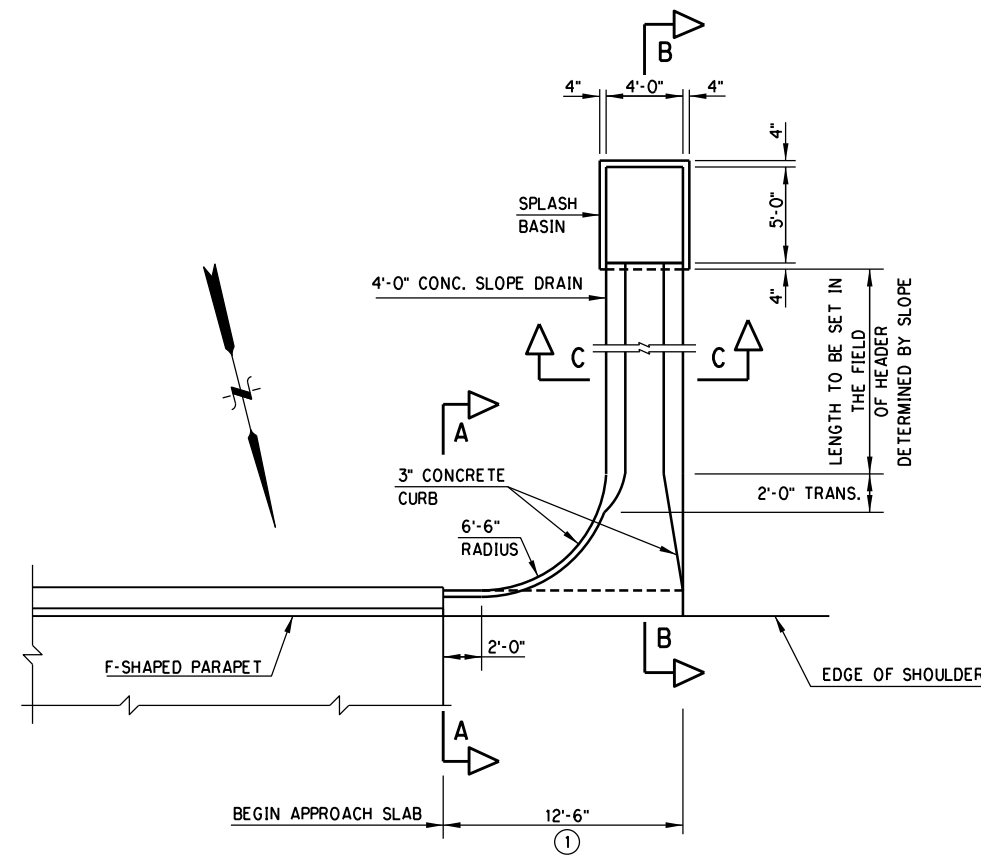

SLOPE DRAIN PLAN
ABUT. NO. 2

① ACTUAL LOCATION OF DRAIN TO BE SET IN THE FIELD.

NOTE:
SLOPE DRAINS AND CURBS SHALL BE CONSTRUCTED USING CLASS "C" CONCRETE AS SHOWN ON THIS SHEET. ALL COSTS OF EXCAVATION, SLOPE DRAINS, CURBS, AND REINFORCING STEEL SHALL BE INCLUDED IN THE PAY ITEM FOR "CLASS "C" CONCRETE".

DESIGN		PHASE 4	OKLAHOMA COUNTY
DRAWN		BRIDGE "A"	RAMP "A" AT I-35 & I-240 EXCHANGE
CHECKED		DRAIN AT END OF BRIDGE DETAILS	
APPROVED			
SQUAD	POE		
		STATE JOB NO. 09032108	SHEET NO. B067

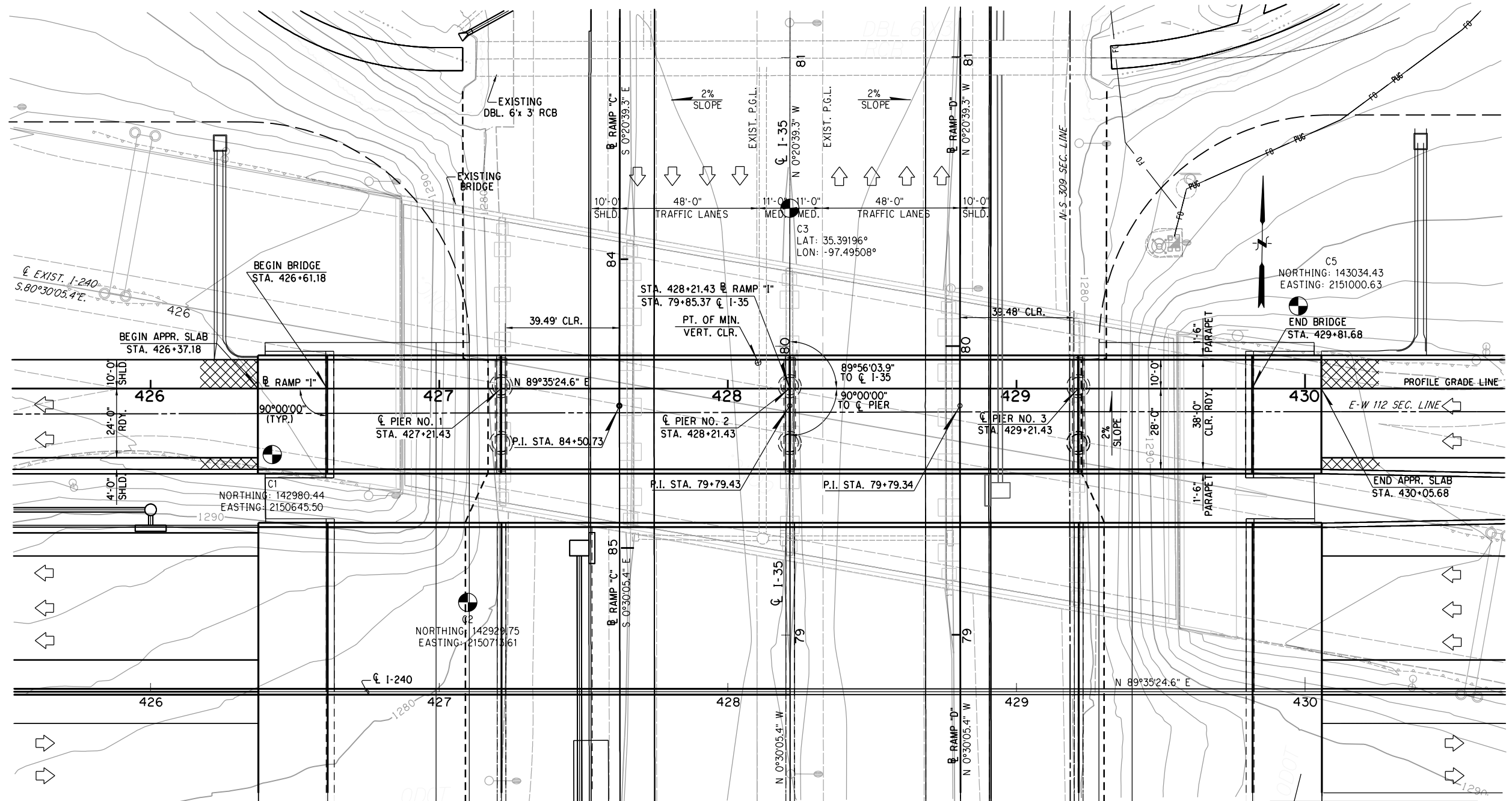

PLAN
SCALE: 1" = 20'-0"

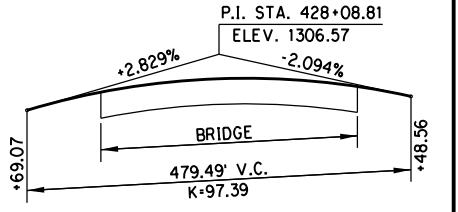

PROFILE GRADE DATA
RAMP "I"

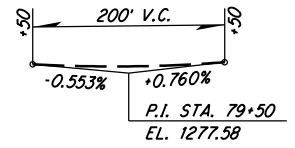

EXIST. PROFILE GRADE DATA
I-35

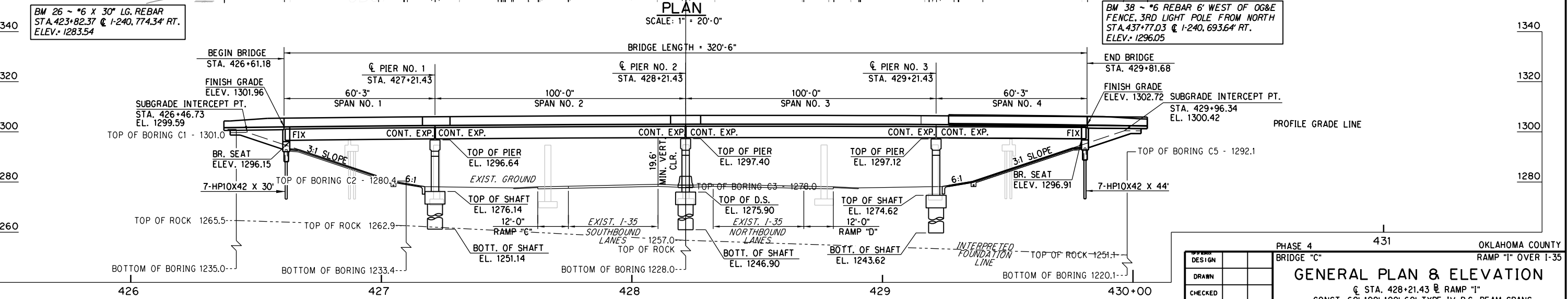

ELEVATION
SCALE: 1" = 20'-0"

BM 26 ~ #6 X 30' LG. REBAR
STA. 423+82.37 @ I-240, 774.34' RT.
ELEV. = 1283.54

BM 38 ~ #6 REBAR 6' WEST OF OG&E
FENCE, 3RD LIGHT POLE FROM NORTH
STA. 437+77.03 @ I-240, 693.64' RT.
ELEV. = 1296.05

DESIGN	
DRAWN	
CHECKED	
APPROVED	
SQUAD	POE

PHASE 4 431 OKLAHOMA COUNTY
BRIDGE "C" RAMP "I" OVER I-35
GENERAL PLAN & ELEVATION
@ STA. 428+21.43 @ RAMP "I"
CONST. 60'-100'-100'-60' TYPE IV P.C. BEAM SPANS
38'-0" CLR. RDY. W/42" F-SHAPED PARAPET
STATE JOB NO. 09032(08) SHEET NO. B068

3/1/2024 2:43:38 PM H:\PROJECTS\2789_Crossroads_Phase 4 Bridge\Drawings\Phase 4 Bridges\Bridges\I-35 Bridge C GPE.dgn

DESIGN DATA

CONCRETE CLASS AA f'c = 4 K.S.I.
 CONCRETE CLASS A f'c = 3 K.S.I.
 REINFORCING STEEL (GRADE 60) Fy = 60 K.S.I.
 STRUCTURAL STEEL AASHTO M270 GRADE 50W Fy = 50 K.S.I.
 STAINLESS STEEL, ASTM A240 (TYPE 316) Fy = 30 K.S.I.

LOADING:
 HL-93 OR OKLAHOMA OVERLOAD TRUCK OR SPECIAL OVERLOAD TRUCK (SEE DIAGRAM THIS SHEET)
 5 PSF SIP STEEL DECK FORM ALLOWANCE
 20 PSF FUTURE WEARING SURFACE

DESIGN:
 AASHTO LRFD BRIDGE DESIGN SPECIFICATIONS, 7TH EDITION
 ANSI/AASHTO/AWS D1.5 WELDING CODE

LRFR OF HL-93 LOADING:
 INVENTORY RATING FACTOR = 1.34
 OPERATING RATING FACTOR = 2.07

FOUNDATION DATA

PIERS (72" DIAMETER DRILLED SHAFTS)	PIER NO. 1 & PIER NO. 3		PIER NO. 2	
FACTORED REACTION (TONS/SHAFT)	633		725	
MINIMUM DEPTH INTO ROCK (FEET)	10'-0"		10'-0"	
NOMINAL UNIT BEARING CAPACITY (TONS/S.F.)	29.6		40.1	
BEARING RESISTANCE FACTOR	0.7		0.7	
FACTORED BEARING RESISTANCE (TONS/SHAFT)	585		794	
NOMINAL UNIT FRICTION RESISTANCE (TONS/S.F.)	3.9		6.0	
FRICTION RESISTANCE FACTOR	0.45		0.45	
DEPTH OF ROCK NEGLECTED FOR FRICTION (FT.)	5'		5'	
FACTORED FRICTION RESISTANCE (TONS/SHAFT)	165		254	
TOTAL FACTORED RESISTANCE (TONS/SHAFT)	750		1048	

ABUTMENTS (HP 10X42 PILING)

FACTORED PILE REACTION (TONS/PILE) = 76.0

STEEL PILING:
 ABUTMENT PILING SHALL BE DRIVEN THROUGH COMPACTED FILL AND SHALL BE DRIVEN TO A POINT BEARING ON SOLID FOUNDATION MATERIAL AT THE APPROXIMATE ELEVATION SHOWN ON THE PLANS. IF THE AXIAL PILE RESISTANCE IS NOT EQUAL TO OR GREATER THAN THE FACTORED PILE REACTION AT THAT ELEVATION, DRIVING SHALL CONTINUE UNTIL THE AXIAL PILE RESISTANCE IS EQUAL TO OR GREATER THAN THE FACTORED PILE REACTION. THE LENGTH OF STEEL PILING SHOWN ON THE PLANS IS FOR ESTIMATING PURPOSES ONLY.

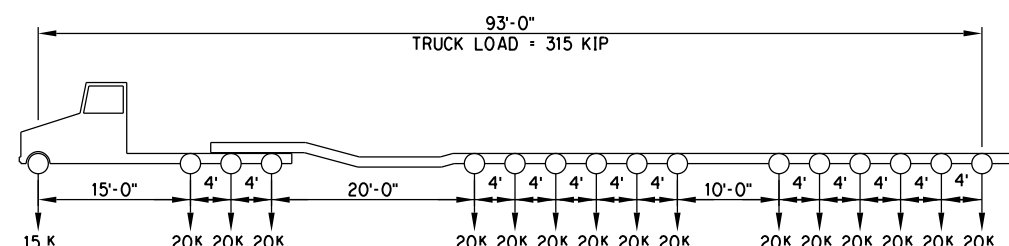

SPECIAL OVERLOAD TRUCK DIAGRAM

SUMMARY OF BRIDGE QUANTITIES								
ITEM	UNIT	ABUTS	PIERS	SUPER STRUCTURE	APPR. SLABS	SLOPE WALLS	PIER PROTECTION	TOTAL
SUBSTRUCTURE EXCAVATION COMMON	C.Y.	90.00	--	--	--	--	--	90.00
CLSM BACKFILL	C.Y.	198.00	--	--	--	--	--	198.00
PRESTRESSED CONCRETE BEAMS (TYPE IV)	L.F.	--	--	1,593.34	--	--	--	1,593.34
APPROACH SLAB	S.Y.	--	--	--	218.80	--	--	218.80
SAW-CUT GROOVING	S.Y.	--	--	1,353.20	202.80	--	--	1,556.00
42" F-SHAPED PARAPET	L.F.	--	--	641.00	96.00	--	--	737.00
STRUCTURAL STEEL	LB.	--	--	1,540.00	--	--	--	1,540.00
WEATHERING STEEL FIXED BEARING ASSEMBLY	EA.	--	--	10.00	--	--	--	10.00
STAINLESS STEEL EXPANSION BEARING ASSEMBLY	EA.	--	--	30.00	--	--	--	30.00
ELASTOMERIC BEARING PADS	EA.	--	--	30.00	--	--	--	30.00
CLASS AA CONCRETE	C.Y.	--	--	396.30	--	--	--	396.30
CLASS A CONCRETE	C.Y.	61.60	216.00	--	--	--	53.20	330.80
CLASS C CONCRETE	C.Y.	--	--	--	--	2.00	--	2.00
SLOPE WALL (5")	S.Y.	--	--	--	--	853.00	--	853.00
REINFORCING STEEL	LB.	--	1,500.00	--	--	--	6,780.00	8,280.00
EPOXY COATED REINFORCING STEEL	LB.	10,420.00	47,700.00	109,000.00	--	--	--	167,120.00
PILES, FURNISHED (HP 10X42)	L.F.	518.00	--	--	--	--	--	518.00
PILES, DRIVEN (HP 10X42)	L.F.	518.00	--	--	--	--	--	518.00
PILES SPLICE, H-PILE (NON-BIDDABLE)	EA.	1.00	--	--	--	--	--	1.00
WATER REPELLENT (VISUALLY INSPECTED)	S.Y.	34.00	156.00	1,485.00	48.00	--	--	1,723.00
DRILLED SHAFTS 72" DIAMETER	L.F.	--	142.00	--	--	--	--	142.00
CROSSHOLE SONIC LOGGING	EA.	--	1.00	--	--	--	--	1.00
ELASTOMERIC COATING	S.F.	--	624.00	--	--	--	--	624.00
SEALER CRACK PREPARATION	L.F.	--	--	228.00	--	--	--	228.00
SEALER RESIN	GAL.	--	--	3.00	--	--	--	3.00
6" PERFORATED PIPE UNDERDRAIN ROUND	L.F.	88.00	--	--	--	122.00	--	210.00
6" NON-PERFORATED PIPE UNDERDRAIN ROUND	L.F.	40.00	--	--	--	40.00	--	80.00
REMOVAL OF EXISTING BRIDGE STRUCTURE	L.SUM	--	--	--	--	--	--	1.00

BRIDGE "C" PHASE 4 INDEX OF SHEETS

SHEET NO.	DESCRIPTION
AB03	SUMMARY OF PAY QUANTITIES (BRIDGE)
AB04	GENERAL NOTES (BRIDGE)
B068	GENERAL PLAN & ELEVATION
B069	DESIGN DATA AND SUMMARY OF QUANTITIES
B070-B071	FOUNDATION REPORT
B072	SUBSTRUCTURE LAYOUT
B073	ABUTMENT EXCAVATION AND UNDERDRAIN DETAILS
B074-B076	ABUTMENT DETAILS
B077-B079	PIER DETAILS
B080-B081	PIER PROTECTION DETAILS
B082-B083	BARRIER TRANSITION DETAILS
B084-B086	SUPERSTRUCTURE DETAILS
B087	LONGITUDINAL SECTION AND DIAPHRAGM DETAILS
B088	PARAPET LAYOUT
B089-B090	TYPE IV P.C.B. DETAILS
B091	BEARING ASSEMBLY DETAILS
B092-B093	APPROACH SLAB DETAILS
B094-B095	SLOPEWALL DETAILS
B096-B097	DRAINS AT END OF BRIDGE DETAILS
2009 BRIDGE STANDARDS	
STD.	EJ-DTL
STD.	FSHP-42-2
STD.	HP1-2
2019 ROADWAY STANDARDS	
STD.	LTU-5
STD.	PUD-4

3/4/2024 2:55:17 PM H:\PROJECTS\2789_CrossRoads_Phase 4\Bridges\Drawings\Ph4 Bridges\Bridges C\0903208 P4 Bridge C.dgn

DESIGN		PHASE 4	OKLAHOMA COUNTY
DRAWN		BRIDGE "C"	RAMP "I" OVER I-35
CHECKED		<p style="text-align: center;">DESIGN DATA AND SUMMARY OF QUANTITIES</p> <p style="text-align: center;">STATE JOB NO. <u>09032(08)</u> SHEET NO. <u>B069</u></p>	
APPROVED			
SQUAD	POE		

BORING NUMBER C-01
NORTHING: 142980.44
EASTING: 215064.55
DATE DRILLED: 10/24/17

BORING NUMBER C-02
NORTHING: 142929.75
EASTING: 2150713.61
DATE DRILLED: 7/19/18

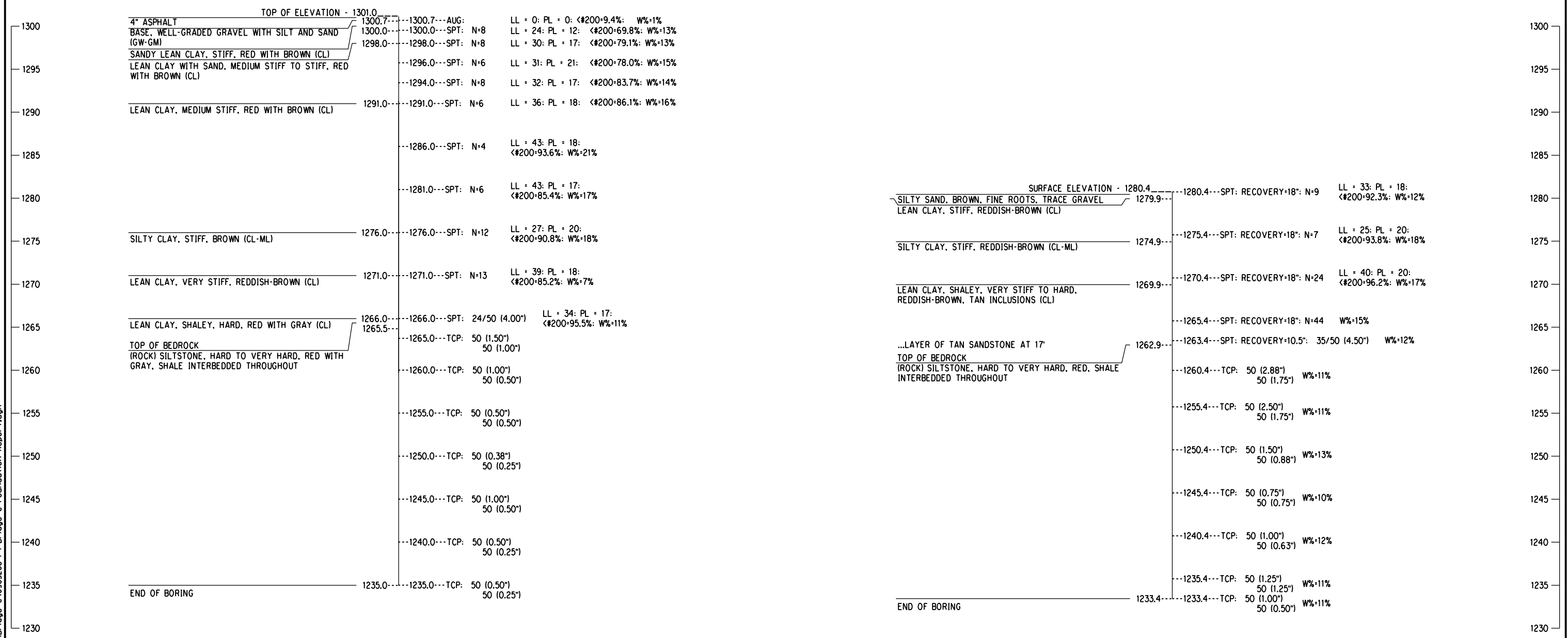

GEOLOGIC STATEMENT

"DIVISION FOUR" OF THE "ENGINEERING CLASSIFICATION OF GEOLOGICAL MATERIALS", PUBLISHED BY THE OKLAHOMA DEPARTMENT OF TRANSPORTATION (ODOT) INDICATES THAT THE SITE IS UNDERLAIN BY THE HENNESSEY UNIT (PHY). THE GEOLOGIC UNIT IS DESCRIBED BELOW. THIS UNIT CONSISTS OF RED PLATY TO BLOCKY CLAY SHALES AND MUDSTONE. THE MUDSTONES ARE HARD AND APPEAR BLOCKY. THE RED CLAY SHALE OF THE HENNESSEY UNIT IS CHARACTERIZED BY NUMEROUS BANDS OF STREAKS OF WHITE OR LIGHT GREEN COLOR RANGING FROM A FEW INCHES TO FOUR FEET IN THICKNESS. THE TOTAL THICKNESS OF THE UNIT IS ABOUT 400 FEET. THE HENNESSEY UNIT OUTCROPS IN A 5- TO 15-MILE NORTH-SOUTH BAND ACROSS GRANT, GARFIELD, KINGFISHER, LOGAN, CANADIAN, AND OKLAHOMA COUNTIES IN DIVISION FOUR. TOPOGRAPHICALLY, THE UNIT IS NEAR LEVEL TO GENTLY ROLLING AND IS GENERALLY GRASS COVERED OR CULTIVATED.

GEOTECHNICAL REPORT

ALL GEOTECHNICAL INFORMATION CONTAINED ON THIS SHEET IS COVERED BY THE ENGINEERING SEAL AFFIXED TO AN ORIGINAL GEOTECHNICAL ENGINEERING REPORT THAT HAS BEEN STAMPED AND SEALED BY A PROFESSIONAL ENGINEER LICENSED IN OKLAHOMA. TO OBTAIN A COPY OF THE COMPLETE REPORT, CONTACT THE ODOT OFFICE ENGINEER AT (405) 521-2625. THE CONTRACTOR SHOULD BE FULLY AWARE OF THE SITE CONDITIONS PRIOR TO BEGINNING WORK. ANY ADDITIONAL GEOTECHNICAL INFORMATION WHICH MAY BE DESIRED IS THE RESPONSIBILITY OF THE CONTRACTOR.

NOTE: SPT - SPLIT SPOON SAMPLING
TCP - TEXAS CONE PENETRATOR TEST
AUG - AUGUR CUTTING SAMPLE
LL - LIQUID LIMIT
PL - PLASTIC LIMIT

<#200 - PERCENT PASSING #200 SIEVE
W% - MOISTURE CONTENT
N - NUMBER OF BLOWS PER 12 INCHES
∇ DENOTES DEPTH TO OBSERVED GROUNDWATER

NOTE: WATER LEVEL ELEVATIONS SHOWN WERE OBTAINED AT THE TIME THE BORINGS WERE DRILLED AND MAY FLUCTUATE THROUGHOUT THE YEAR.

PROFESSIONAL SERVICE INDUSTRIES, INC.

DESIGN	
DRAWN	
CHECKED	
APPROVED	
SQUAD	POE

PHASE 4 OKLAHOMA COUNTY

BRIDGE "C" RAMP "I" OVER I-35

FOUNDATION REPORT
(SHEET 1 OF 2)

STATE JOB NO. 09032(08) SHEET NO. B070

3/1/2024 2:43:42 PM H:\PROJECTS\2789_CrossRoads_Phase 4\Bridges\Drawings\Ph4 Bridges\Bridges C Foundation Report.dgn

Boring Number C-03
Northing: -
Easting: -
Date Drilled: 6/3/18

Boring Number C-05
Northing: 143034.43
Easting: 2151000.63
Date Drilled: 10/24/18

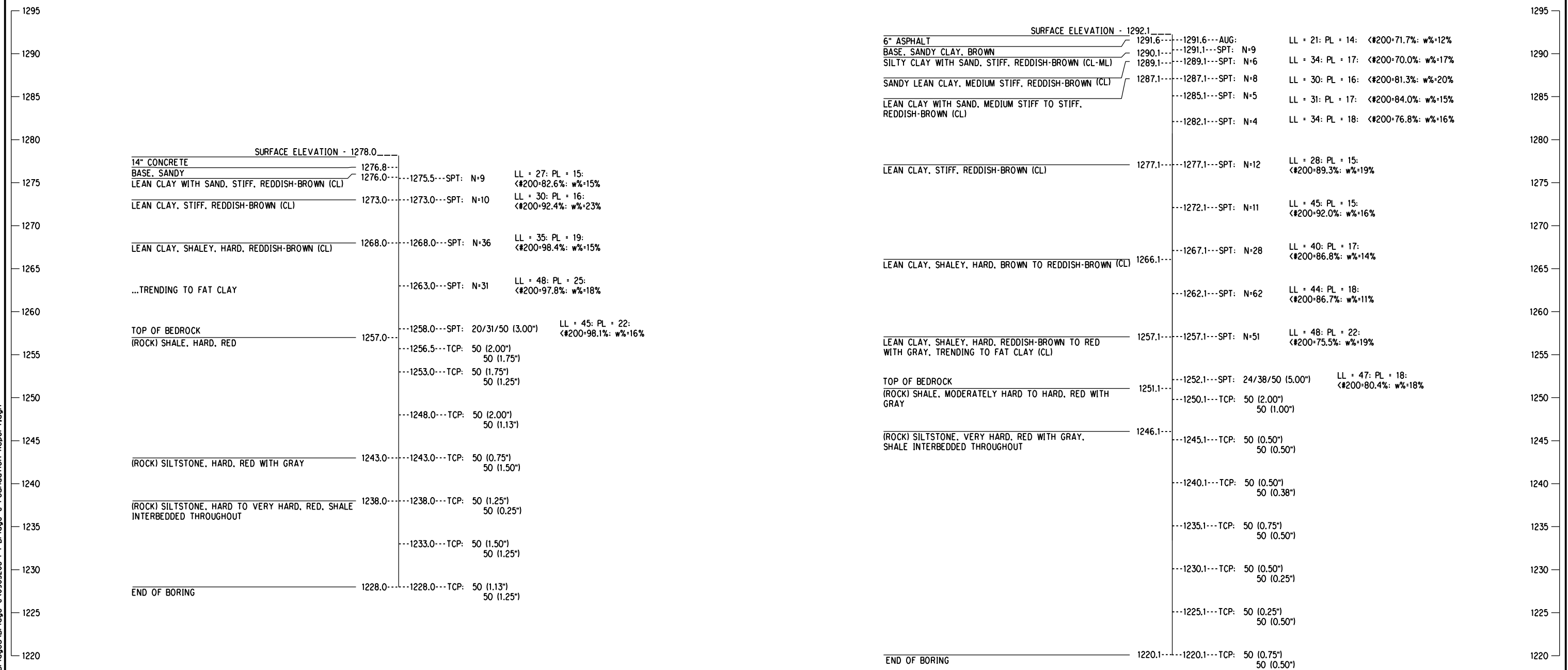

GEOLOGIC STATEMENT

"DIVISION FOUR" OF THE "ENGINEERING CLASSIFICATION OF GEOLOGICAL MATERIALS", PUBLISHED BY THE OKLAHOMA DEPARTMENT OF TRANSPORTATION (ODOT) INDICATES THAT THE SITE IS UNDERLAIN BY THE HENNESSEY UNIT (PHY). THE GEOLOGIC UNIT IS DESCRIBED BELOW.
THIS UNIT CONSISTS OF RED PLATY TO BLOCKY CLAY SHALES AND MUDSTONE. THE MUDSTONES ARE HARD AND APPEAR BLOCKY. THE RED CLAY SHALE OF THE HENNESSEY UNIT IS CHARACTERIZED BY NUMEROUS BANDS OF STREAKS OF WHITE OR LIGHT GREEN COLOR RANGING FROM A FEW INCHES TO FOUR FEET IN THICKNESS. THE TOTAL THICKNESS OF THE UNIT IS ABOUT 400 FEET.
THE HENNESSEY UNIT OUTCROPS IN A 5- TO 15-MILE NORTH-SOUTH BAND ACROSS GRANT, GARFIELD, KINGFISHER, LOGAN, CANADIAN, AND OKLAHOMA COUNTIES IN DIVISION FOUR. TOPOGRAPHICALLY, THE UNIT IS NEAR LEVEL TO GENTLY ROLLING AND IS GENERALLY GRASS COVERED OR CULTIVATED.

GEOTECHNICAL REPORT

ALL GEOTECHNICAL INFORMATION CONTAINED ON THIS SHEET IS COVERED BY THE ENGINEERING SEAL AFFIXED TO AN ORIGINAL GEOTECHNICAL ENGINEERING REPORT THAT HAS BEEN STAMPED AND SEALED BY A PROFESSIONAL ENGINEER LICENSED IN OKLAHOMA. TO OBTAIN A COPY OF THE COMPLETE REPORT, CONTACT THE ODOT OFFICE ENGINEER AT (405) 521-2625. THE CONTRACTOR SHOULD BE FULLY AWARE OF THE SITE CONDITIONS PRIOR TO BEGINNING WORK. ANY ADDITIONAL GEOTECHNICAL INFORMATION WHICH MAY BE DESIRED IS THE RESPONSIBILITY OF THE CONTRACTOR.

NOTE: SPT - SPLIT SPOON SAMPLING
TCP - TEXAS CONE PENETRATOR TEST
AUG - AUGUR CUTTING SAMPLE
LL - LIQUID LIMIT
PL - PLASTIC LIMIT

<#200 - PERCENT PASSING #200 SIEVE
w% - MOISTURE CONTENT
N - NUMBER OF BLOWS PER 12 INCHES
∇ DENOTES DEPTH TO OBSERVED GROUNDWATER

NOTE: WATER LEVEL ELEVATIONS SHOWN WERE OBTAINED AT THE TIME THE BORINGS WERE DRILLED AND MAY FLUCTUATE THROUGHOUT THE YEAR.

PROFESSIONAL SERVICE INDUSTRIES, INC.

DESIGN	
DRAWN	
CHECKED	
APPROVED	
SQUAD	POE

PHASE 4 OKLAHOMA COUNTY

BRIDGE "C" RAMP "I" OVER I-35

FOUNDATION REPORT
(SHEET 2 OF 2)

STATE JOB NO. 09032(08) SHEET NO. B071

3/1/2024 2:43:43 PM H:\PROJECTS\2789_CrossRoads_Phase 4\Bridges\Drawings\Ph4 Bridges\Bridges C Foundation Report.dgn

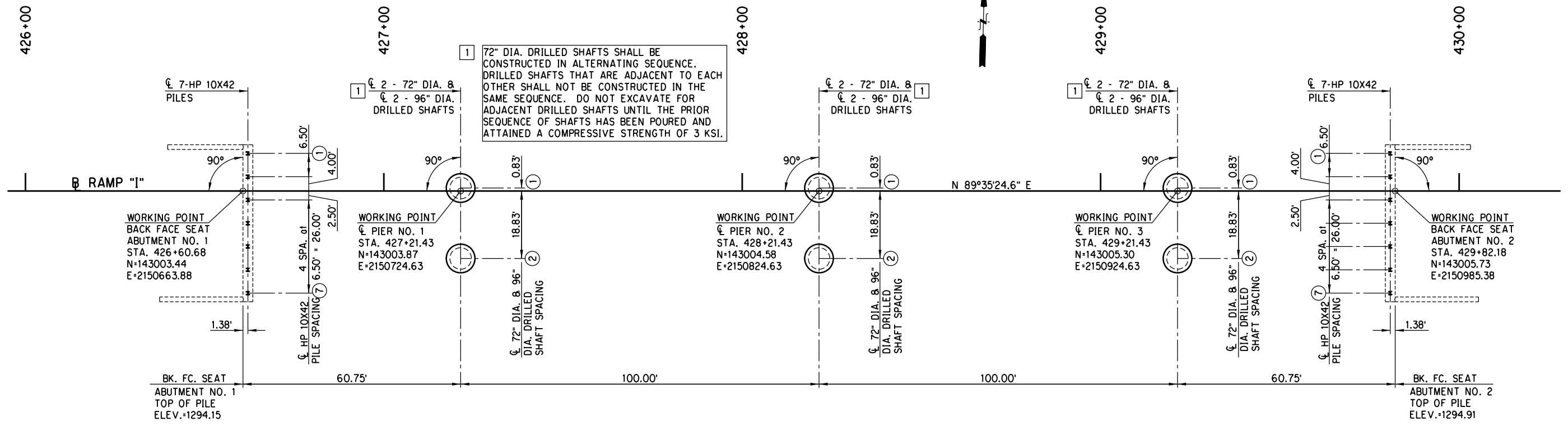

72" DIA. DRILLED SHAFTS SHALL BE CONSTRUCTED IN ALTERNATING SEQUENCE. DRILLED SHAFTS THAT ARE ADJACENT TO EACH OTHER SHALL NOT BE CONSTRUCTED IN THE SAME SEQUENCE. DO NOT EXCAVATE FOR ADJACENT DRILLED SHAFTS UNTIL THE PRIOR SEQUENCE OF SHAFTS HAS BEEN POURED AND ATTAINED A COMPRESSIVE STRENGTH OF 3 KSI.

NOTE: ABUTMENT PILES SHALL BE ORIENTED SUCH THAT THE FACE OF THE PILE WEB IS PARALLEL WITH THE FACE OF THE BRIDGE SEAT.

SUBSTRUCTURE STAKING DIAGRAM

3/1/2024 2:43:44 PM H:\PROJECTS\2789_CrossRoads_Phase 4\Bridges\Drawings\Bridges\Bridges\0903208 P4 Bridge C Staking.dgn

DESIGN		PHASE 4	OKLAHOMA COUNTY
DRAWN		BRIDGE "C"	RAMP "1" OVER I-35
CHECKED		SUBSTRUCTURE LAYOUT	
APPROVED			
SQUAD			
POE		STATE JOB NO. 09032108	SHEET NO. B072

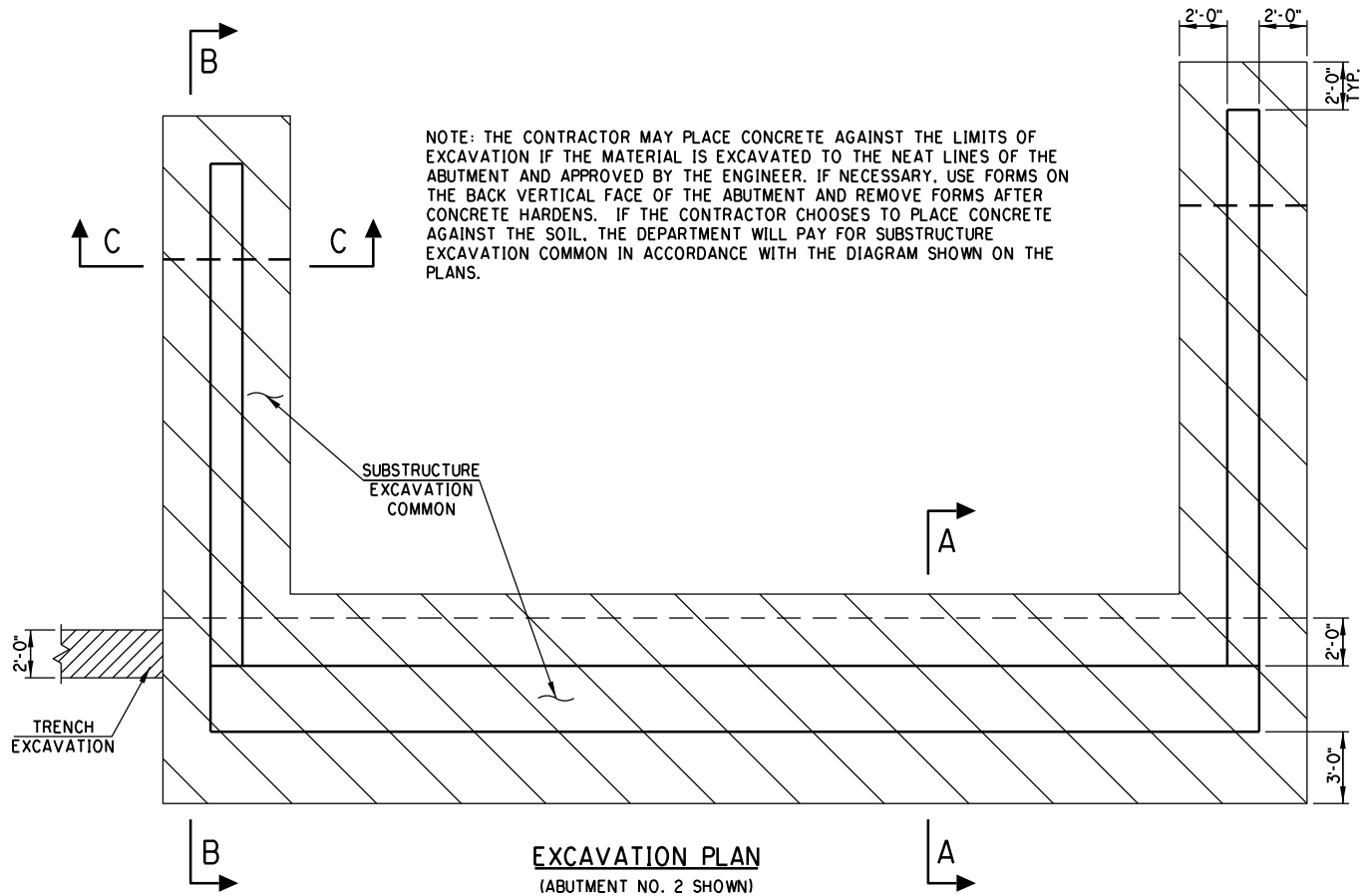

NOTE: THE CONTRACTOR MAY PLACE CONCRETE AGAINST THE LIMITS OF EXCAVATION IF THE MATERIAL IS EXCAVATED TO THE NEAT LINES OF THE ABUTMENT AND APPROVED BY THE ENGINEER. IF NECESSARY, USE FORMS ON THE BACK VERTICAL FACE OF THE ABUTMENT AND REMOVE FORMS AFTER CONCRETE HARDENS. IF THE CONTRACTOR CHOOSES TO PLACE CONCRETE AGAINST THE SOIL, THE DEPARTMENT WILL PAY FOR SUBSTRUCTURE EXCAVATION COMMON IN ACCORDANCE WITH THE DIAGRAM SHOWN ON THE PLANS.

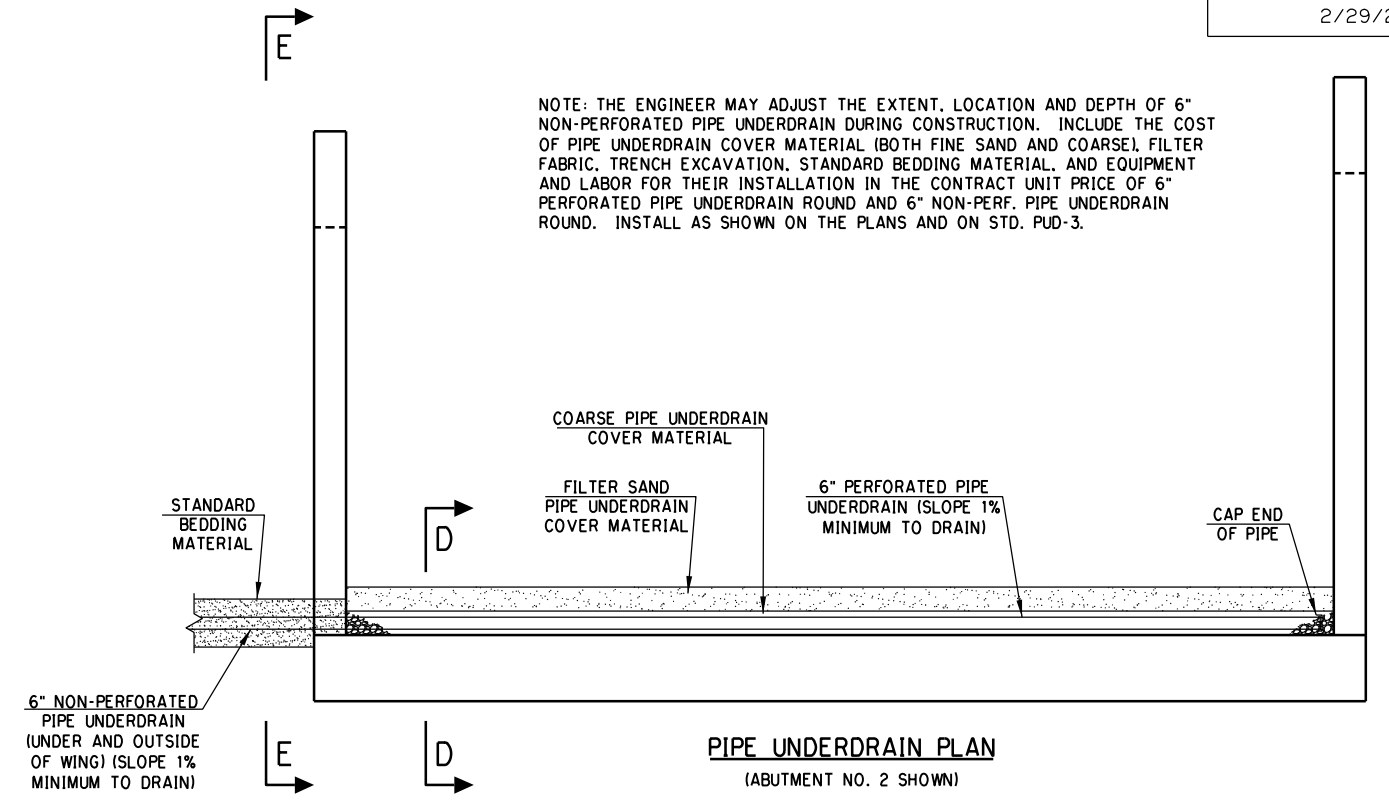

NOTE: THE ENGINEER MAY ADJUST THE EXTENT, LOCATION AND DEPTH OF 6" NON-PERFORATED PIPE UNDERDRAIN DURING CONSTRUCTION. INCLUDE THE COST OF PIPE UNDERDRAIN COVER MATERIAL (BOTH FINE SAND AND COARSE), FILTER FABRIC, TRENCH EXCAVATION, STANDARD BEDDING MATERIAL, AND EQUIPMENT AND LABOR FOR THEIR INSTALLATION IN THE CONTRACT UNIT PRICE OF 6" PERFORATED PIPE UNDERDRAIN ROUND AND 6" NON-PERF. PIPE UNDERDRAIN ROUND. INSTALL AS SHOWN ON THE PLANS AND ON STD. PUD-3.

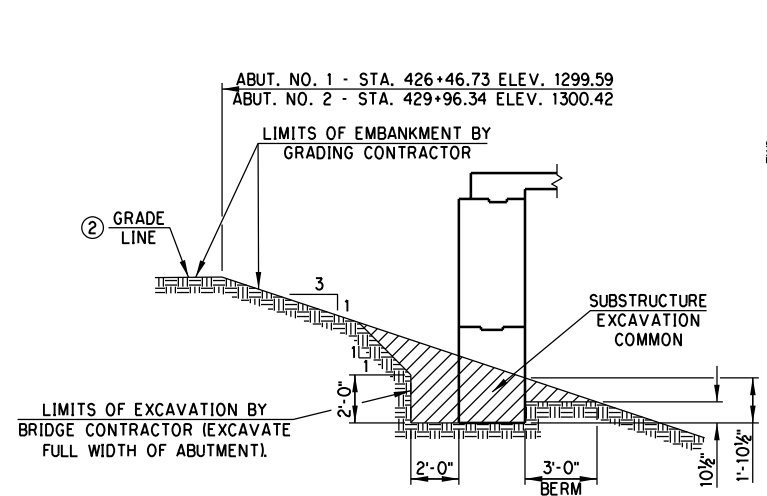

ABUT. NO. 1 - STA. 426+46.73 ELEV. 1299.59
ABUT. NO. 2 - STA. 429+96.34 ELEV. 1300.42

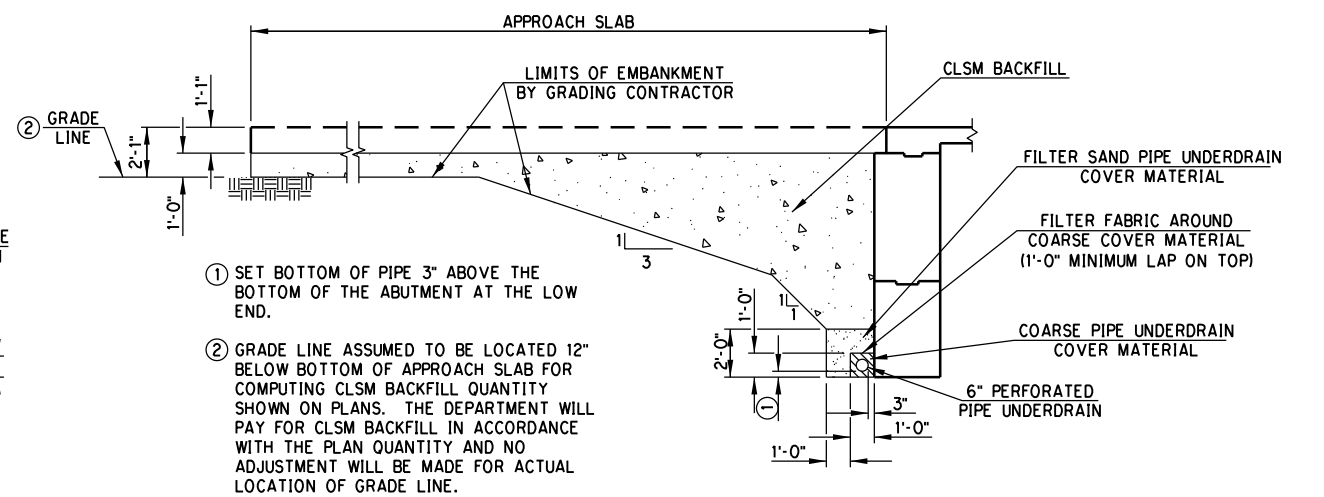
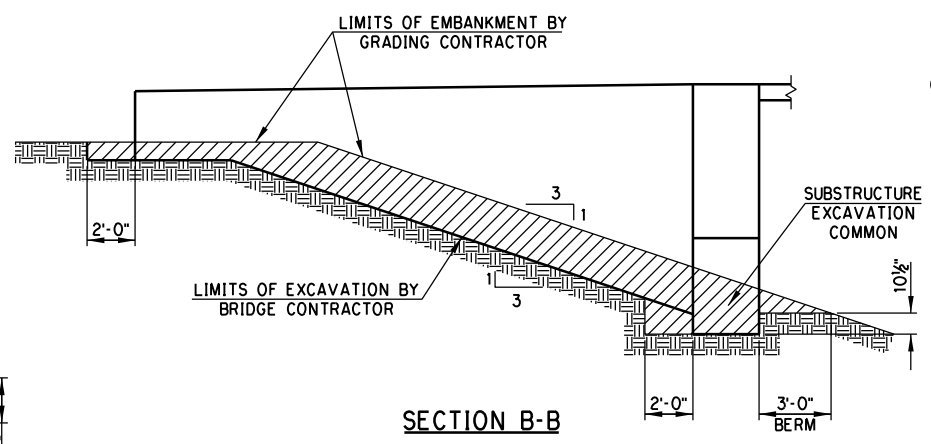

- ① SET BOTTOM OF PIPE 3" ABOVE THE BOTTOM OF THE ABUTMENT AT THE LOW END.
- ② GRADE LINE ASSUMED TO BE LOCATED 12" BELOW BOTTOM OF APPROACH SLAB FOR COMPUTING CLSM BACKFILL QUANTITY SHOWN ON PLANS. THE DEPARTMENT WILL PAY FOR CLSM BACKFILL IN ACCORDANCE WITH THE PLAN QUANTITY AND NO ADJUSTMENT WILL BE MADE FOR ACTUAL LOCATION OF GRADE LINE.

DO NOT PLACE CLSM BACKFILL UNTIL SUPERSTRUCTURE IS IN PLACE AND THE ABUTMENT WING CONCRETE HAS ATTAINED A STRENGTH OF 3000 P.S.I.

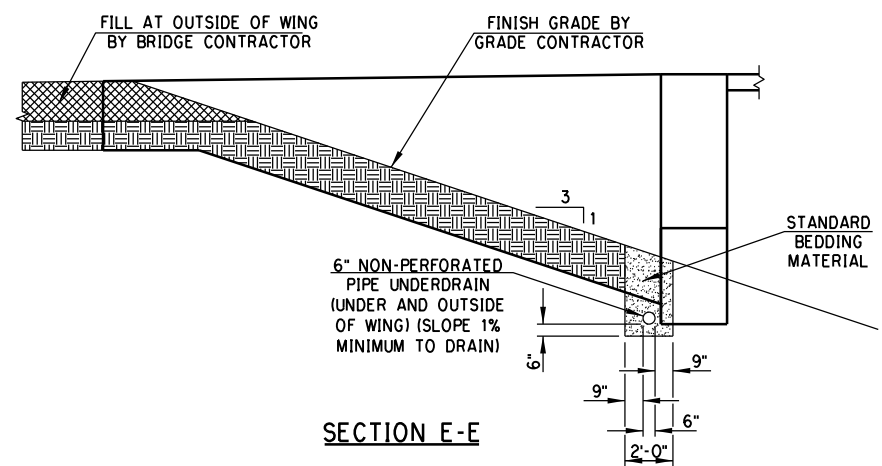
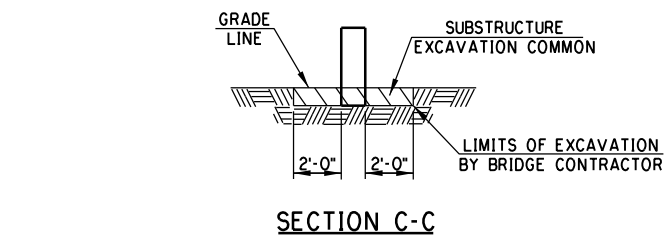

3/1/2024 2:43:44 PM H:\PROJECTS\2789_CrossRoads_Phase 4\Bridges\Drawings\Ph4 Bridges\Bridges\Excavation Diagram.dgn

DESIGN		PHASE 4		OKLAHOMA COUNTY	
DRAWN		BRIDGE "C"		RAMP "1" OVER 1-35	
CHECKED		ABUTMENT EXCAVATION AND UNDERDRAIN DETAILS			
APPROVED					
SQUAD					
POE		STATE JOB NO. 09032(08) SHEET NO. B073			

NOTE: PLACE ALL WT WING REINFORCING TIED TO ABUTMENT SEAT REINFORCING BEFORE PLACING ABUTMENT SEAT CONCRETE.

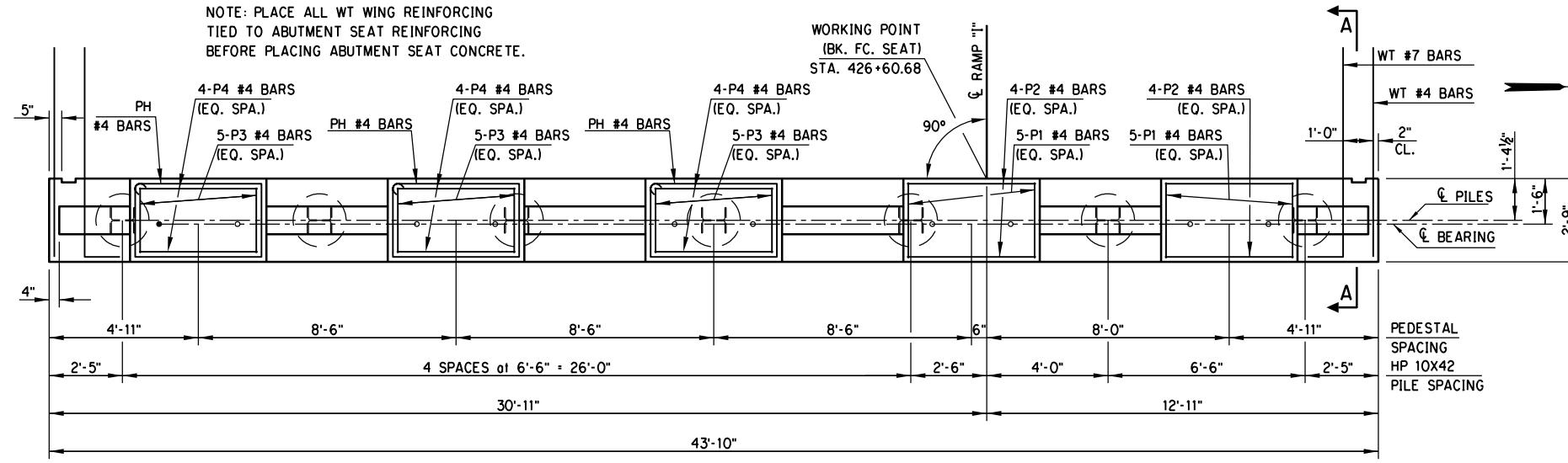

PLAN - ABUTMENT NO. 1 SEAT

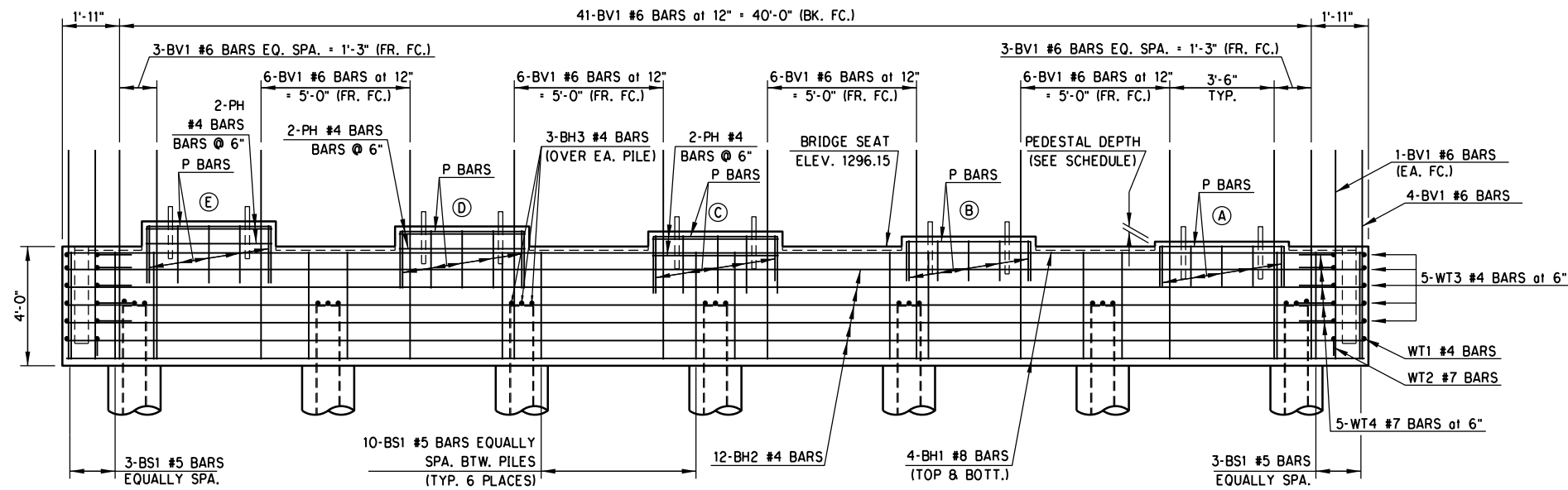

ELEVATION - ABUTMENT NO. 1 SEAT

PEDESTAL ELEVATION SCHEDULE					
PEDESTAL	A	B	C	D	E
ELEVATION	1,296.32	1,296.49	1,296.66	1,296.83	1,297.00
DEPTH	2"	4-1/16"	6-1/16"	8-1/8"	10-3/16"

ABUTMENT QUANTITIES				
ITEM	UNIT	ABUT. NO. 1	ABUT. NO. 2	TOTAL
SUBSTRUCTURE EXCAVATION COMMON	C.Y.	45.00	45.00	90.00
CLSM BACKFILL	C.Y.	99.00	99.00	198.00
CLASS A CONCRETE	C.Y.	30.70	30.90	61.60
EPOXY COATED REINFORCING STEEL	LB.	5,210.00	5,210.00	10,420.00
PILES, FURNISHED (HP 10X42)	L.F.	210.00	308.00	518.00
PILES, DRIVEN (HP 10X42)	L.F.	210.00	308.00	518.00
WATER REPELLENT (VISUALLY INSPECTED)	S.Y.	17.00	17.00	34.00
6" PERFORATED PIPE UNDERDRAIN ROUND	L.F.	44.00	44.00	88.00
6" NON-PERFORATED PIPE UNDERDRAIN ROUND	L.F.	20.00	20.00	40.00

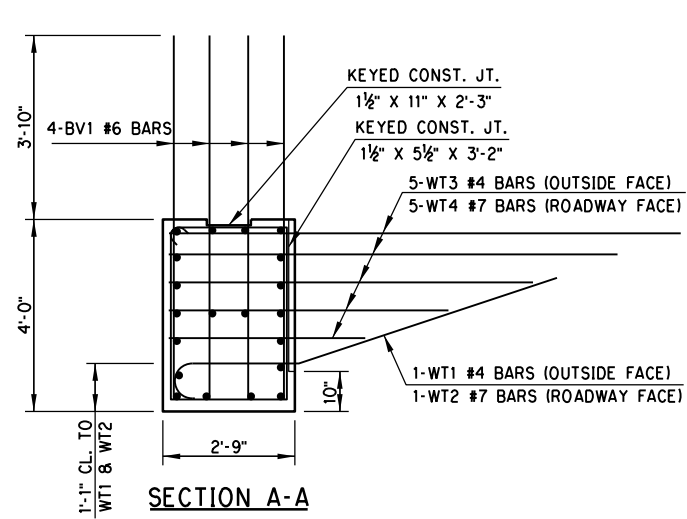

SECTION A-A

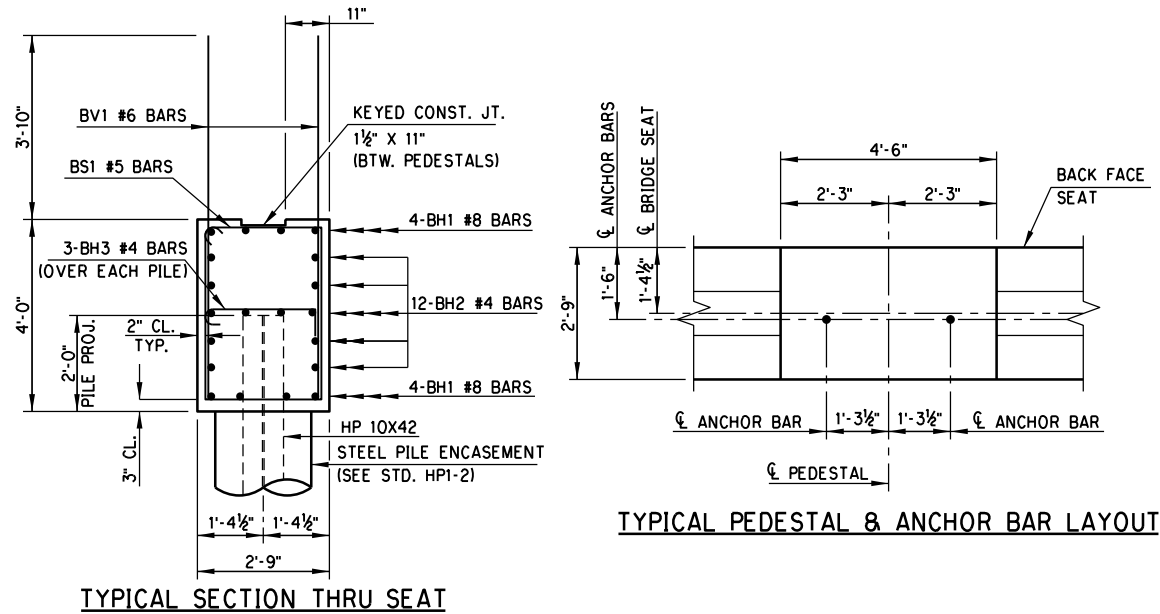

TYPICAL SECTION THRU SEAT

TYPICAL PEDESTAL & ANCHOR BAR LAYOUT

NOTE: FOR BAR LIST, SEE SHEET 3 OF 3. FOR WATER REPELLENT DETAILS, SEE "SUPERSTRUCTURE DETAILS" SHEET.

DESIGN	
DRAWN	
CHECKED	
APPROVED	
SQUAD	POE

PHASE 4
BRIDGE "C"
OKLAHOMA COUNTY
RAMP "1" OVER 1-35
ABUTMENT DETAILS
(SHEET 1 OF 3)
STATE JOB NO. 09032108 SHEET NO. B074

3/1/2024 2:43:46 PM H:\PROJECTS\2789_CrossRoads_Phase 4\Bridges\Drawings\Phase 4\Bridges\Bridges\0903208 P4 Bridge C Abutment.dgn

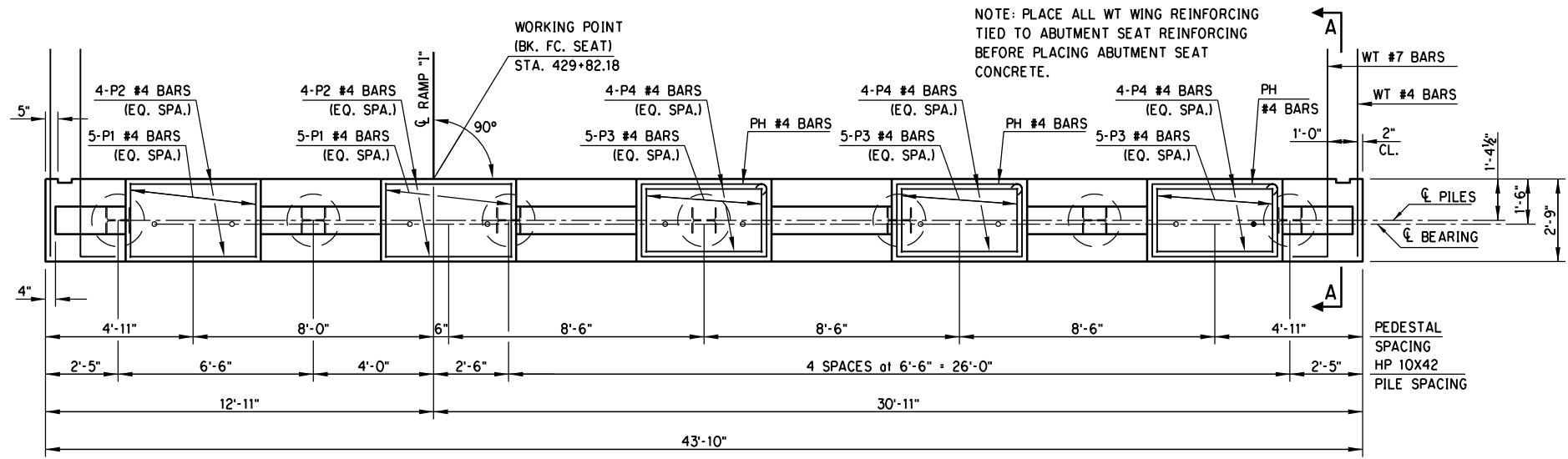

PLAN - ABUTMENT NO. 2 SEAT

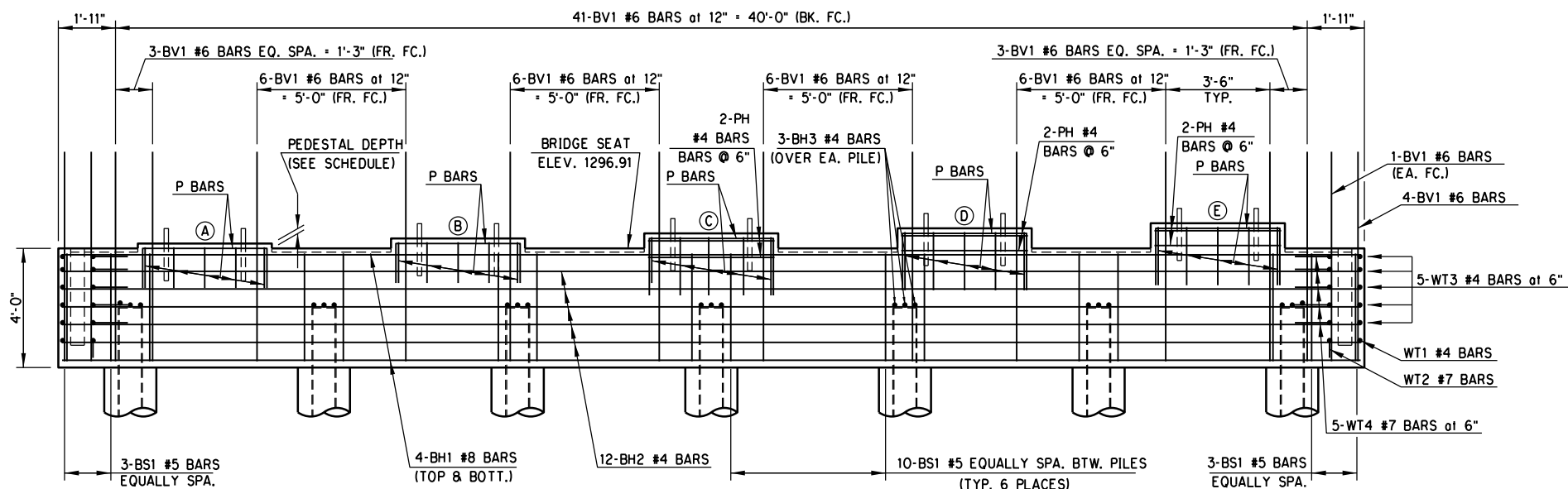

ELEVATION - ABUTMENT NO. 2 SEAT

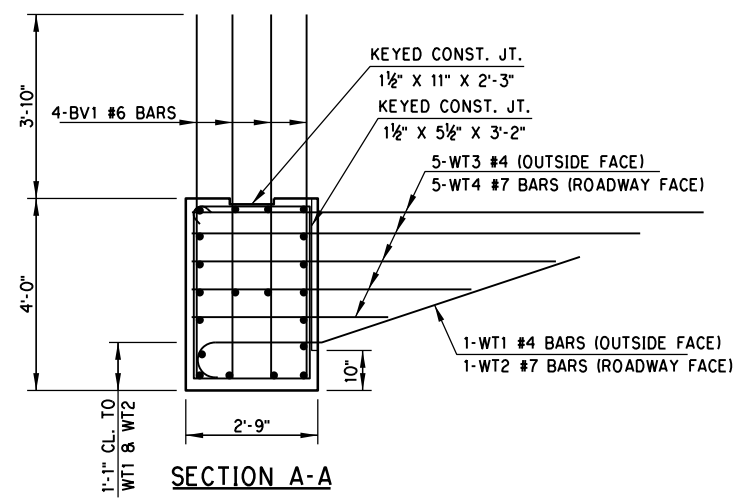

SECTION A-A

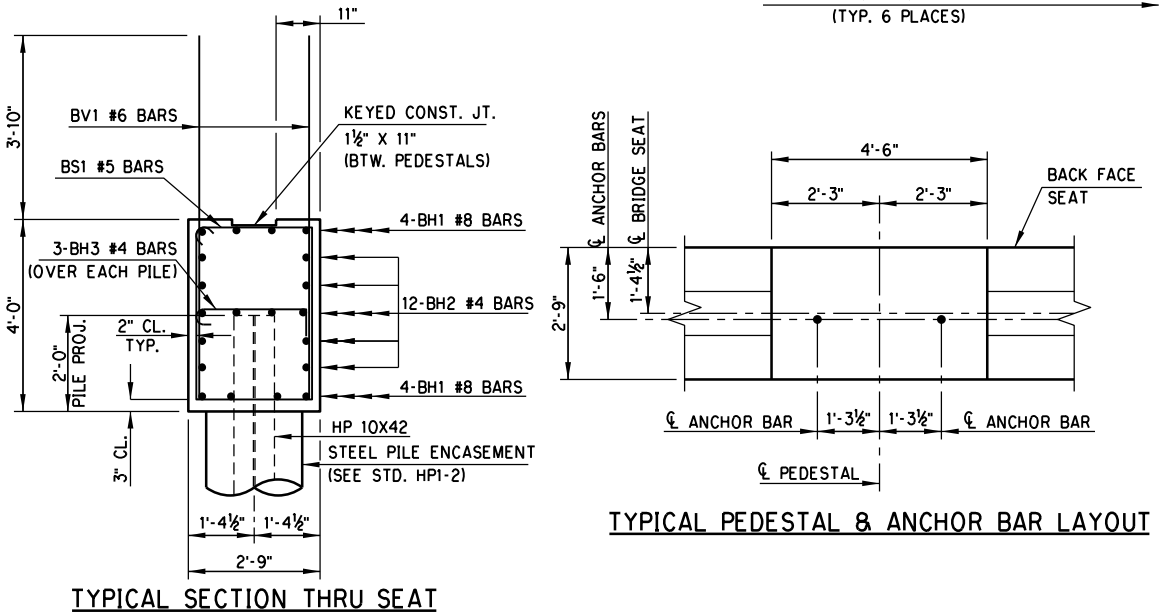

TYPICAL SECTION THRU SEAT

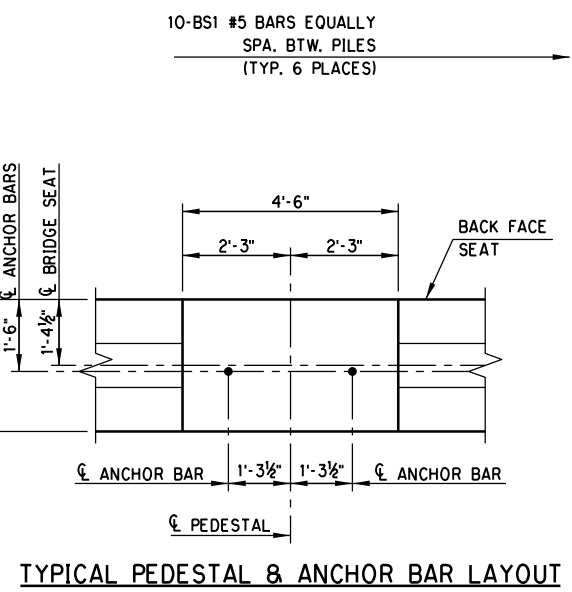

TYPICAL PEDESTAL & ANCHOR BAR LAYOUT

PEDESTAL ELEVATION SCHEDULE					
PEDESTAL	A	B	C	D	E
ELEVATION	1,297.07	1,297.24	1,297.41	1,297.58	1,297.75
DEPTH	2"	4-1/16"	6-1/16"	8-1/8"	10-3/16"

NOTE: FOR BAR LIST, SEE SHEET 3 OF 3. FOR WATER REPELLENT DETAILS, SEE "SUPERSTRUCTURE DETAILS" SHEET.

DESIGN		PHASE 4	OKLAHOMA COUNTY
DRAWN		BRIDGE "C"	RAMP "1" OVER 1-35
CHECKED		ABUTMENT DETAILS (SHEET 2 OF 3)	
APPROVED			
SQUAD	POE	STATE JOB NO. 09032108 SHEET NO. B075	

3/1/2024 2:43:47 PM H:\PROJECTS\2789_CrossRoads_Phase 4\Bridges\Drawings\Ph4 Bridges\Bridges\0903208 P4 Bridge C Abutment.dgn

90% PLAN SUBMITTAL
2/29/2024

ELEV. 1301.30 (ABUT. NO. 1)
ELEV. 1302.16 (ABUT. NO. 2)

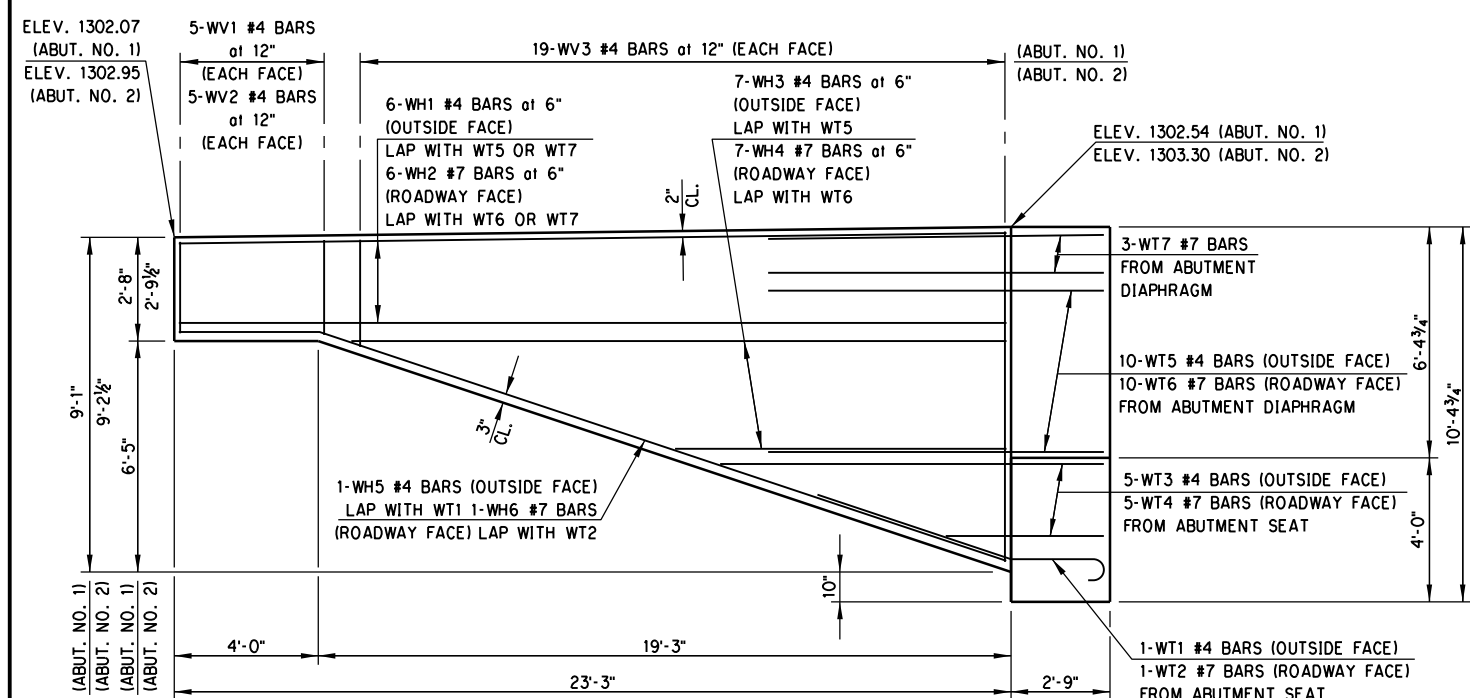

ABUT. NO. 1 SOUTH WING ELEVATION (SHOWN)
ABUT. NO. 2 SOUTH WING ELEVATION (OPPOSITE HAND)

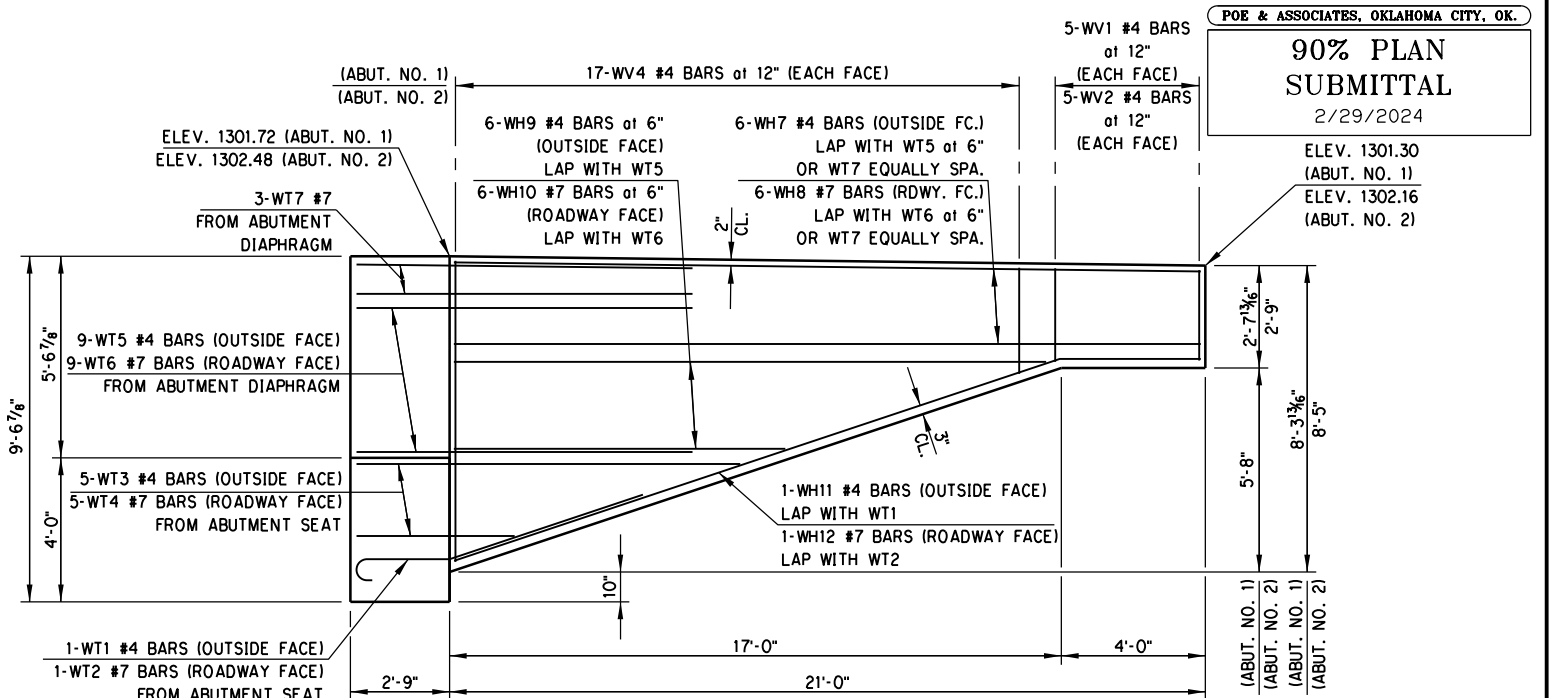

ABUT. NO. 1 NORTH WING ELEVATION (SHOWN)
ABUT. NO. 2 NORTH WING ELEVATION (OPPOSITE HAND)

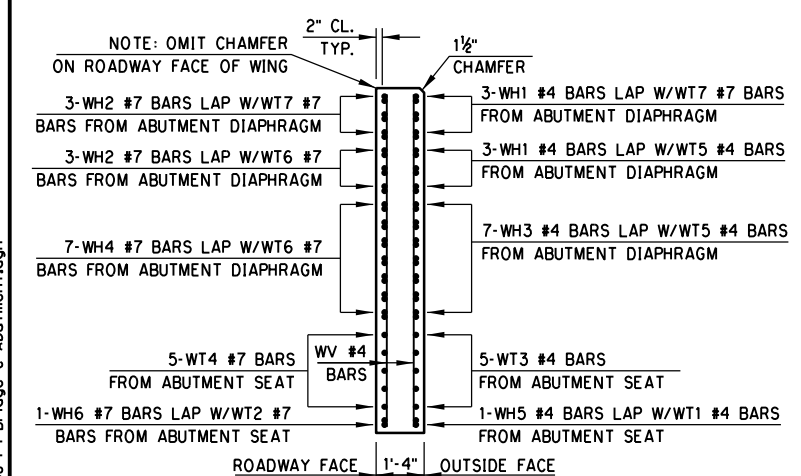

SECTION THROUGH SOUTH WING
at BACK FACE OF ABUTMENT SEAT
(ABUT. NO. 1 & ABUT. NO. 2)

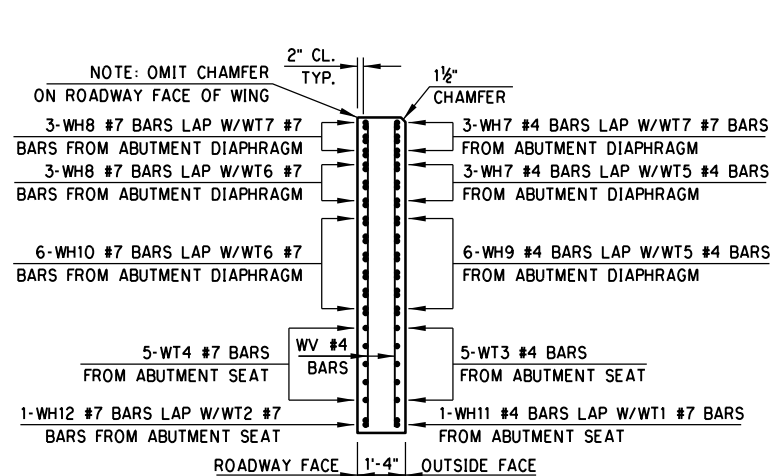

SECTION THROUGH NORTH WING
at BACK FACE OF ABUTMENT SEAT
(ABUT. NO. 1 & ABUT. NO. 2)

ABUTMENT NO. 1 BAR LIST
(EPOXY COATED)

MARK	SIZE	NO.	FORM	SPACING	LENGTH	VARIANCE
BH1	#8	8	STR.	EQ. SPA.	43'-6"	--
BH2	#4	12	STR.	EQ. SPA.	43'-6"	--
BH3	#4	21	BNT.	AS SHOWN	3'-7"	--
BS1	#5	66	BNT.	EQ. SPA.	12'-11"	--
BV1	#6	83	STR.	12" C/C	7'-0"	--
P1	#4	10	BNT.	EQ. SPA.	5'-1"	--
P2	#4	8	BNT.	EQ. SPA.	6'-10"	--
P3	#4	15	BNT.	EQ. SPA.	6'-2"	--
P4	#4	12	BNT.	EQ. SPA.	7'-11"	--
PH	#4	6	BNT.	6" C/C	13'-11"	--
WT1	#4	2	BNT.	AS SHOWN	5'-2"	--
WT2	#7	2	BNT.	AS SHOWN	9'-1"	--
① WT3	#4	10	STR.	EQ. SPA.	7'-0" AVG.	3'-11" TO 10'-1"
① WT4	#7	10	BNT.	EQ. SPA.	8'-2" AVG.	5'-1" TO 11'-3"
WH1	#4	6	STR.	6" C/C	22'-11"	--
WH2	#7	6	STR.	6" C/C	22'-11"	--
WH3	#4	7	STR.	6" C/C	13'-7" AVG.	9'-1" TO 18'-1"
WH4	#7	7	STR.	6" C/C	13'-7" AVG.	9'-1" TO 18'-1"
WH5	#4	1	BNT.	AS SHOWN	23'-11"	--
WH6	#7	1	BNT.	AS SHOWN	23'-11"	--
WH7	#4	6	STR.	6" C/C	20'-8"	--
WH8	#7	6	STR.	6" C/C	20'-8"	--
WH9	#4	6	STR.	6" C/C	12'-10" AVG.	9'-1" TO 16'-7"
WH10	#7	6	STR.	6" C/C	12'-10" AVG.	9'-1" TO 16'-7"
WH11	#4	1	BNT.	AS SHOWN	21'-6"	--
WH12	#7	1	BNT.	AS SHOWN	21'-6"	--
WV1	#4	20	STR.	12" C/C	2'-3"	--
② WV3	#4	38	STR.	12" C/C	5'-10" AVG.	2'-8" TO 9'-0"
③ WV4	#4	34	STR.	12" C/C	5'-5" AVG.	2'-8" TO 8'-2"

- ① 2 SETS OF 5
- ② 2 SETS OF 19
- ③ 2 SETS OF 17

ABUTMENT NO. 2 BAR LIST
(EPOXY COATED)

MARK	SIZE	NO.	FORM	SPACING	LENGTH	VARIANCE
BH1	#8	8	STR.	EQ. SPA.	43'-6"	--
BH2	#4	12	STR.	EQ. SPA.	43'-6"	--
BH3	#4	21	BNT.	AS SHOWN	3'-7"	--
BS1	#5	66	BNT.	EQ. SPA.	12'-11"	--
BV1	#6	83	STR.	12" C/C	7'-0"	--
P1	#4	10	BNT.	EQ. SPA.	5'-1"	--
P2	#4	8	BNT.	EQ. SPA.	6'-10"	--
P3	#4	15	BNT.	EQ. SPA.	6'-2"	--
P4	#4	12	BNT.	EQ. SPA.	7'-11"	--
PH	#4	6	BNT.	6" C/C	13'-11"	--
WT1	#4	2	BNT.	AS SHOWN	5'-2"	--
WT2	#7	2	BNT.	AS SHOWN	9'-1"	--
① WT3	#4	10	STR.	EQ. SPA.	7'-0" AVG.	3'-11" TO 10'-1"
① WT4	#7	10	BNT.	EQ. SPA.	8'-2" AVG.	5'-1" TO 11'-3"
WH1	#4	6	STR.	6" C/C	22'-11"	--
WH2	#7	6	STR.	6" C/C	22'-11"	--
WH3	#4	7	STR.	6" C/C	13'-7" AVG.	9'-1" TO 18'-1"
WH4	#7	7	STR.	6" C/C	13'-7" AVG.	9'-1" TO 18'-1"
WH5	#4	1	BNT.	AS SHOWN	23'-11"	--
WH6	#7	1	BNT.	AS SHOWN	23'-11"	--
WH7	#4	6	STR.	6" C/C	20'-8"	--
WH8	#7	6	STR.	6" C/C	20'-8"	--
WH9	#4	6	STR.	6" C/C	12'-10" AVG.	9'-1" TO 16'-7"
WH10	#7	6	STR.	6" C/C	12'-10" AVG.	9'-1" TO 16'-7"
WH11	#4	1	BNT.	AS SHOWN	21'-6"	--
WH12	#7	1	BNT.	AS SHOWN	21'-6"	--
WV2	#4	20	STR.	12" C/C	2'-4"	--
② WV3	#4	38	STR.	12" C/C	5'-10" AVG.	2'-8" TO 9'-0"
③ WV4	#4	34	STR.	12" C/C	5'-5" AVG.	2'-8" TO 8'-2"

- ① 2 SETS OF 5
- ② 2 SETS OF 19
- ③ 2 SETS OF 17

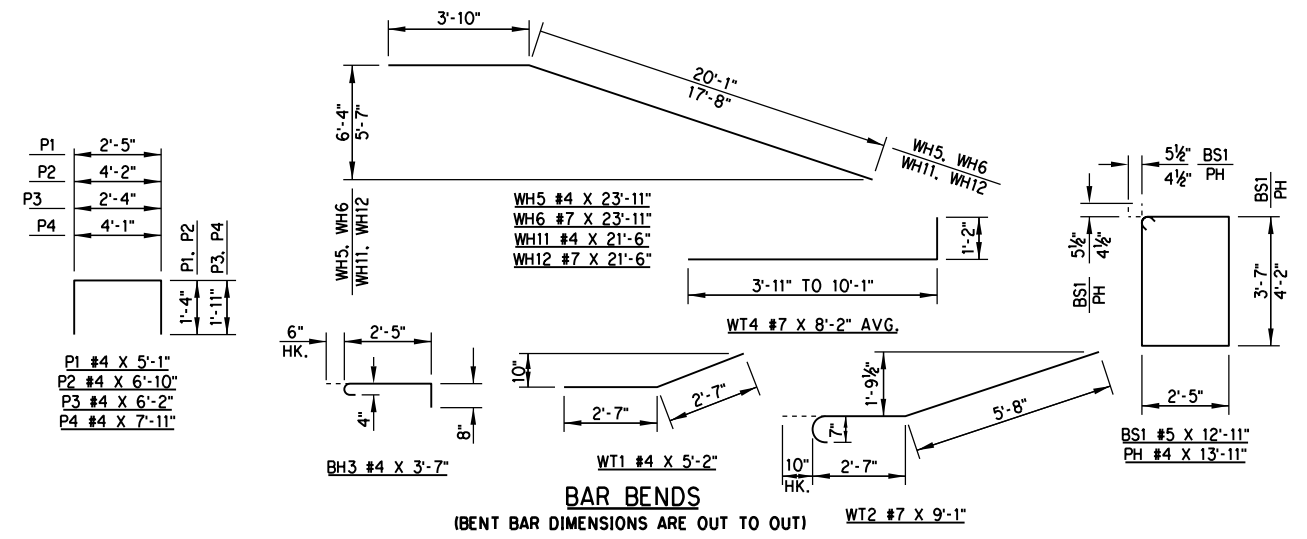

BAR BENDS

(BENT BAR DIMENSIONS ARE OUT TO OUT)

PHASE 4 OKLAHOMA COUNTY
BRIDGE "C" RAMP "1" OVER I-35
ABUTMENT DETAILS
(SHEET 3 OF 3)
STATE JOB NO. 09032108 SHEET NO. B076

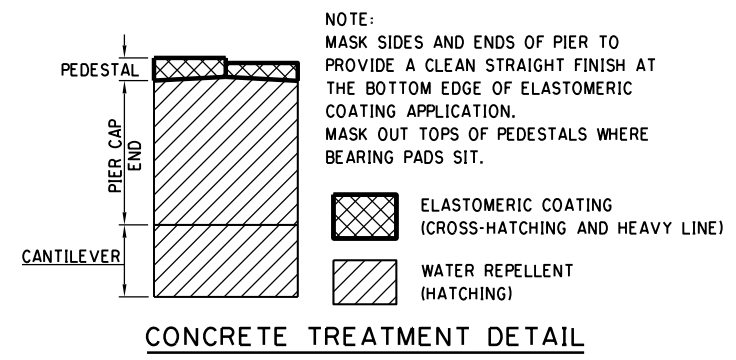
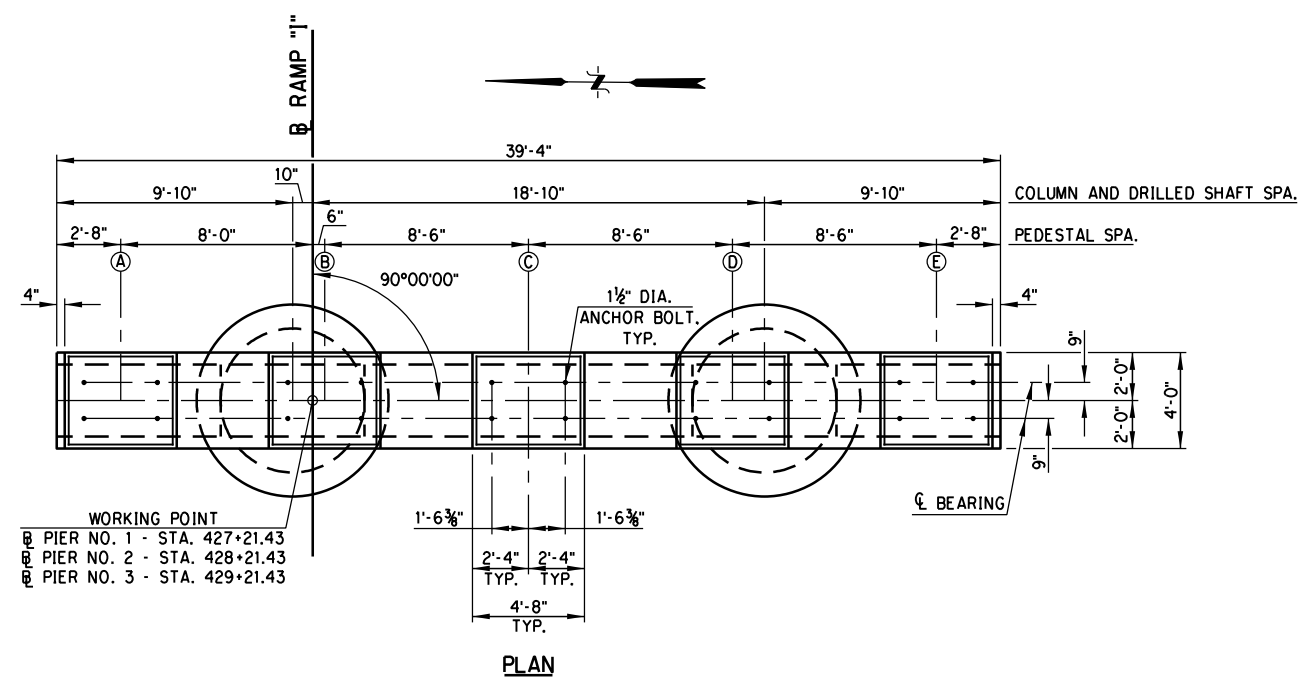

PIER QUANTITIES

ITEM	UNIT	PIER NO. 1	PIER NO. 2	PIER NO. 3	TOTAL
CLASS A CONCRETE	C.Y.	70.70	72.00	73.30	216.00
REINFORCING STEEL	LB.	500.00	500.00	500.00	1,500.00
EPOXY COATED REINFORCING STEEL	LB.	15,620.00	15,900.00	16,180.00	47,700.00
WATER REPELLENT (VISUALLY INSPECTED)	S.Y.	52.00	52.00	52.00	156.00
DRILLED SHAFTS 72" DIAMETER	L.F.	40.00	48.00	54.00	142.00
CROSSHOLE SONIC LOGGING	EA.	-	-	-	1.00
ELASTOMERIC COATING	S.F.	208.00	208.00	208.00	624.00

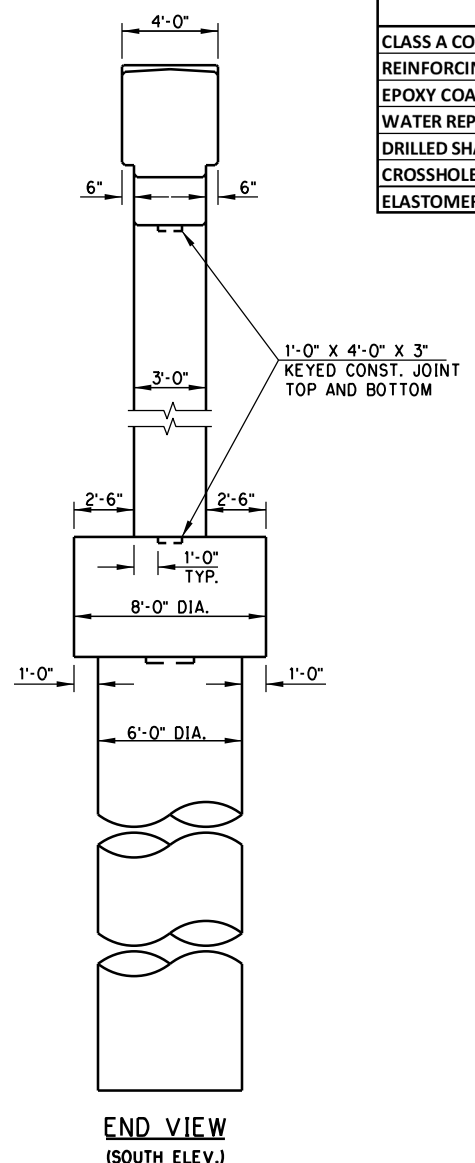
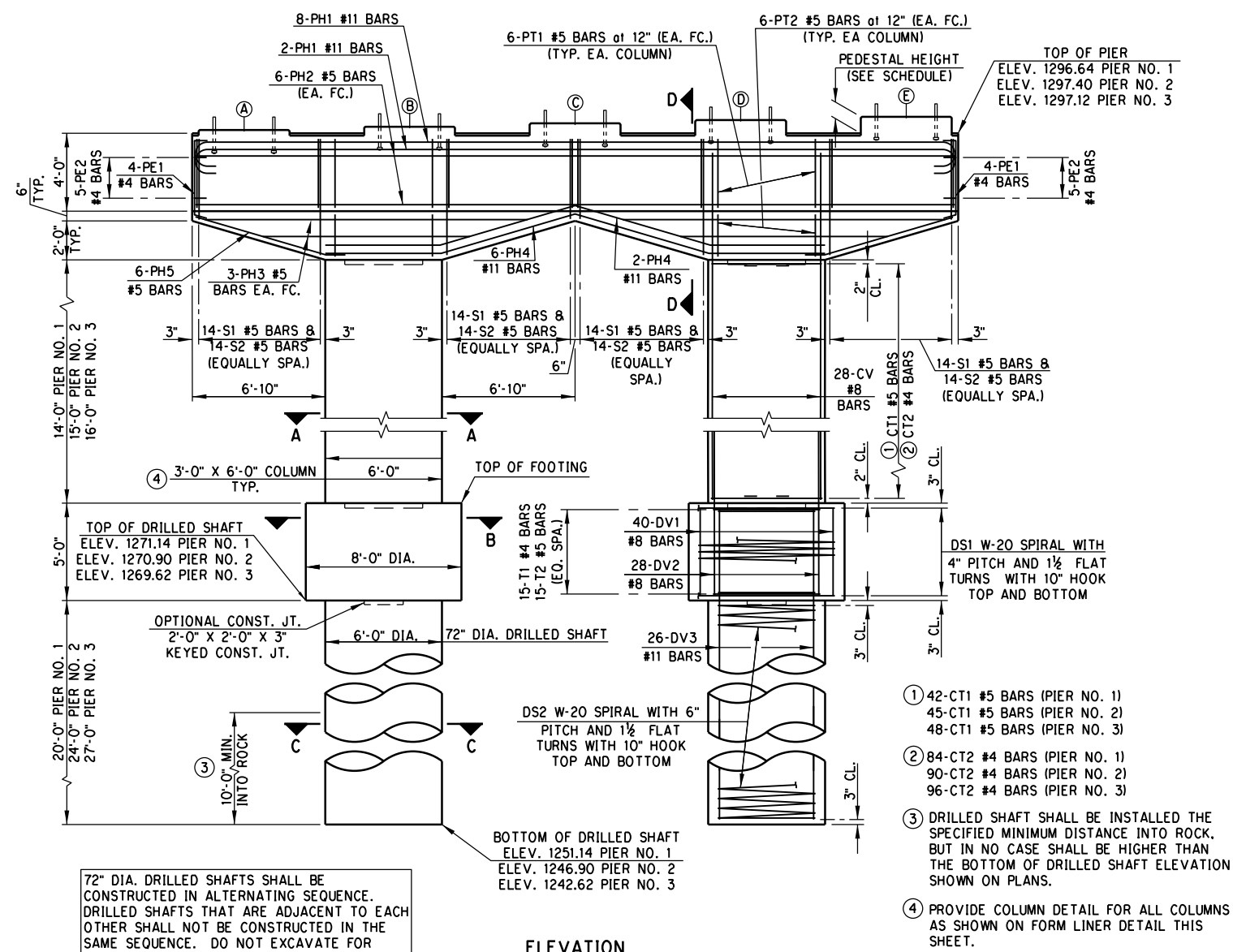

PEDESTAL ELEVATION SCHEDULE

	PEDESTAL	A	B	C	D	E
PIER NO. 1	ELEVATION	1,296.89	1,297.06	1,297.23	1,297.40	1,297.57
	DEPTH	3"	5-1/16"	7-1/16"	9-1/8"	11-3/16"
PIER NO. 2	ELEVATION	1,297.65	1,297.82	1,297.99	1,298.16	1,298.33
	DEPTH	3"	5-1/16"	7-1/16"	9-1/8"	11-3/16"
PIER NO. 3	ELEVATION	1,297.38	1,297.55	1,297.72	1,297.89	1,298.06
	DEPTH	3"	5-1/16"	7-1/16"	9-1/8"	11-3/16"

- ① 42-CT1 #5 BARS (PIER NO. 1)
45-CT1 #5 BARS (PIER NO. 2)
48-CT1 #5 BARS (PIER NO. 3)
- ② 84-CT2 #4 BARS (PIER NO. 1)
90-CT2 #4 BARS (PIER NO. 2)
96-CT2 #4 BARS (PIER NO. 3)
- ③ DRILLED SHAFT SHALL BE INSTALLED THE SPECIFIED MINIMUM DISTANCE INTO ROCK, BUT IN NO CASE SHALL BE HIGHER THAN THE BOTTOM OF DRILLED SHAFT ELEVATION SHOWN ON PLANS.
- ④ PROVIDE COLUMN DETAIL FOR ALL COLUMNS AS SHOWN ON FORM LINER DETAIL THIS SHEET.

NOTE: FOR PEDESTAL REINFORCING DETAIL SEE SHEET 3 OF 3.

FOR SECTIONS A-A, B-B, C-C & D-D, SEE SHEET 2 OF 3.

FOR BAR BENDS AND BAR LISTS, SEE SHEET 3 OF 3.

PHASE 4 OKLAHOMA COUNTY
 BRIDGE "C" RAMP "1" OVER 1-35

PIER DETAILS
 (SHEET 1 OF 3)

STATE JOB NO. 09032108 SHEET NO. B077

DESIGN	
DRAWN	
CHECKED	
APPROVED	
SQUAD	POE

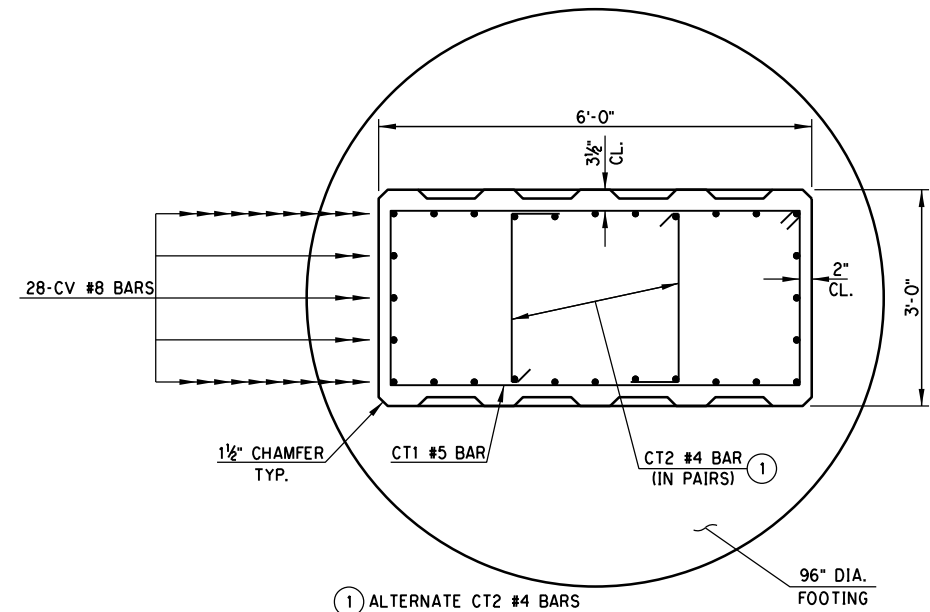

① ALTERNATE CT2 #4 BARS END TO END FOR EACH SUCCESSIVE ROW.

SECTION A-A

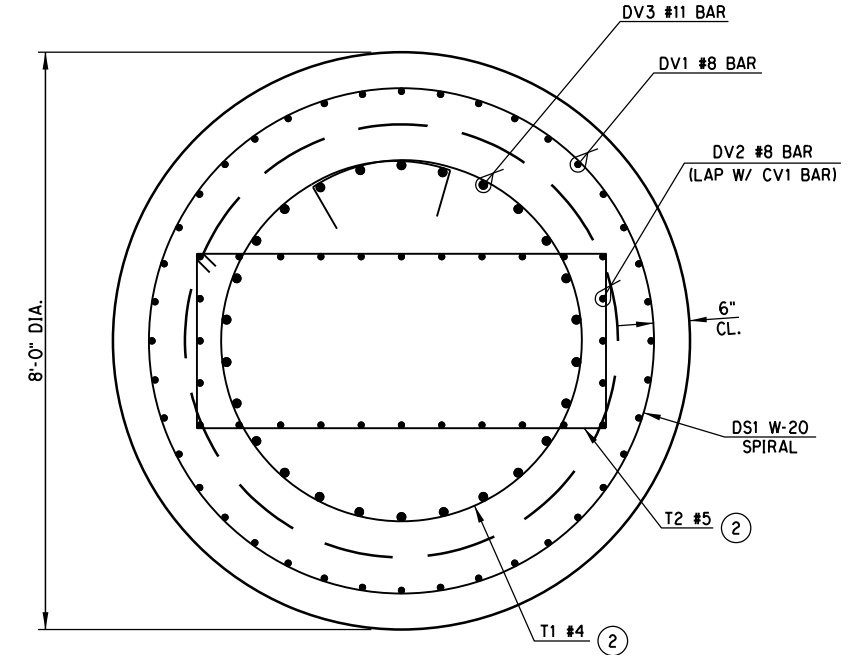

② ROTATE BARS 180 DEGREES FOR EACH SUCCESSIVE ROW.

SECTION B-B

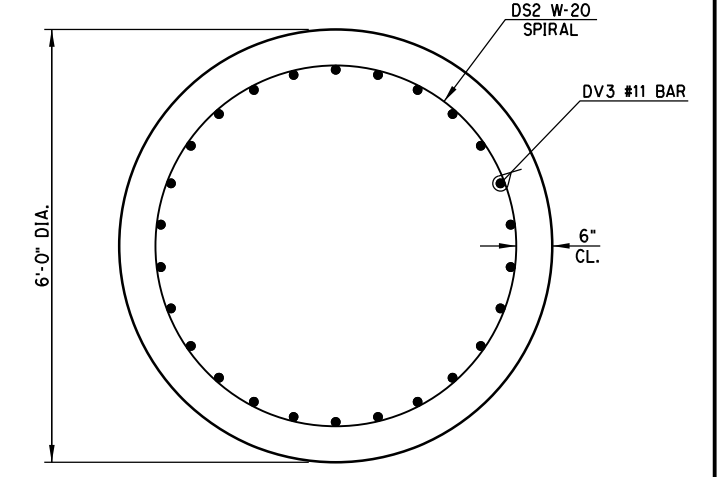

SECTION C-C

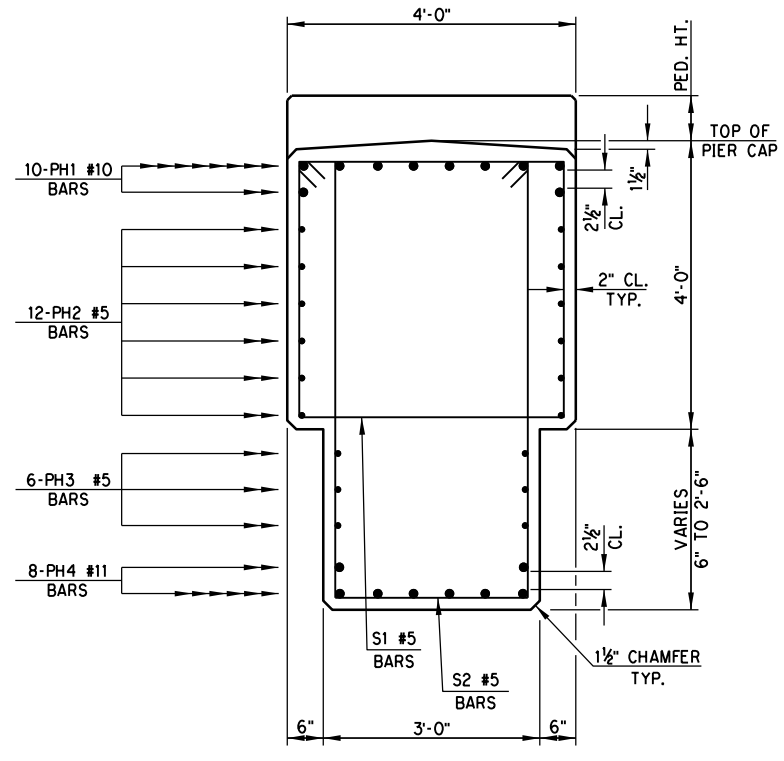

SECTION D-D

ROLLER INSTALLATION DETAIL

ROLLERS PER MANUFACTURER'S SPECIFICATIONS (SPREAD SPIRAL BAR TO ALLOW ROLLER CLEARANCE)

1" P.V.C. PIPE CAST INTO CENTER OF ROLLER

#6 BAR TIED TO VERTICAL REINFORCING

ROLLER PLACEMENT

ROLLERS LOCATED AT ONE-FIFTH POINTS ON 10'-0" CTRS.

ROLLER DETAILS

NOTE: REINFORCING CAGE CENTERING DEVICES SHALL CONSIST OF ROLLERS PLACED AT SPACING AS SHOWN AND HAVE THE CHARACTERISTICS AS INDICATED IN THE MANUFACTURER'S SPECIFICATIONS. SLAB BOLSTERS AND HIGH CHAIRS WILL BE ALLOWED BY THE DEPARTMENT.

SPIRAL REINFORCING SPLICE DETAILS

NOTE: SPIRAL BARS SHALL CONFORM TO AASHTO M-32. SPIRAL BAR LENGTHS DO NOT INCLUDE LAP. IF LAP IS REQUIRED, THE LENGTH OF THE LAP SHALL BE AS SHOWN.

1 1/2" DIA. 135° HOOK W/ 10" TAIL

2'-0" MIN. LAP

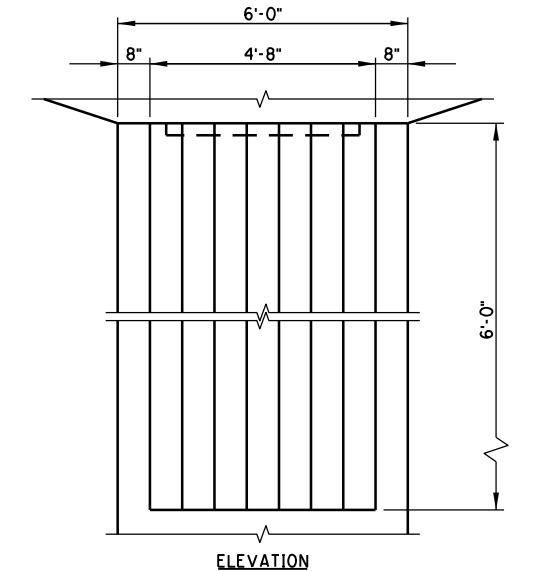

ELEVATION

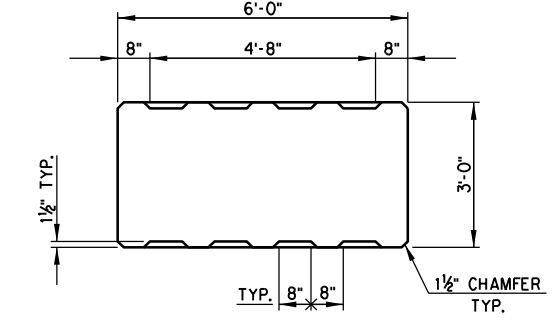

SECTION FORM LINER DETAIL (BOTH FACES OF ALL PIER COLUMNS)

3/1/2024 2:43:52 PM H:\PROJECTS\2789_CrossRoads_Phase 4\Bridges\Drawings\Ph4 Bridges\Bridges\0903208 P4 Bridge C Pier.dgn

DESIGN		PHASE 4	OKLAHOMA COUNTY
DRAWN		BRIDGE "C"	RAMP "1" OVER 1-35
CHECKED		PIER DETAILS (SHEET 2 OF 3)	
APPROVED			
SQUAD	POE		
		STATE JOB NO. 09032108	SHEET NO. B078

3/1/2024 2:43:53 PM H:\PROJECTS\2789_CrossRoads_Phase 4\Bridges\Drawings\Ph4 Bridges\Bridg C 0903208 P4 Bridge C Pier.dgn

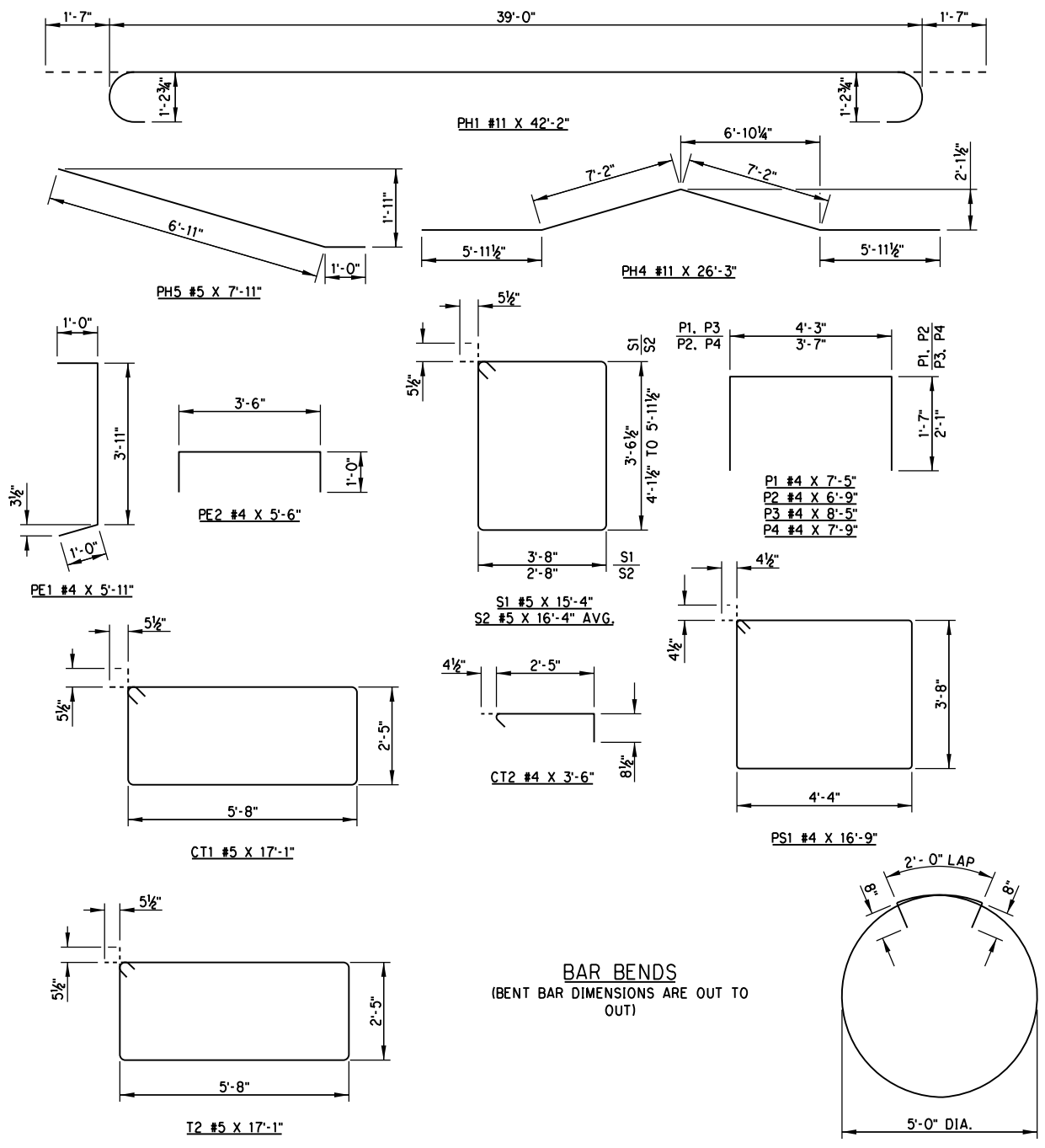

MARK	SIZE	NO.	FORM	SPACING	LENGTH	VARIANCE
CT1	#5	84	BNT.	4" C/C	17'-1"	--
CT2	#4	468	BNT.	4" C/C	3'-6"	--
CV1	#8	56	STR.	AS SHOWN	19'-6"	--
DS1	W-20	2	BNT.	AS SHOWN	362'-5"	--
DV1	#8	80	STR.	AS SHOWN	4'-6"	--
DV2	#8	56	STR.	AS SHOWN	12'-6"	--
P1	#4	10	BNT.	EQ. SPA.	7'-5"	--
P2	#4	12	BNT.	EQ. SPA.	6'-9"	--
P3	#4	15	BNT.	EQ. SPA.	8'-5"	--
P4	#4	18	BNT.	EQ. SPA.	7'-9"	--
PE1	#4	8	BNT.	AS SHOWN	5'-11"	--
PE2	#4	10	BNT.	AS SHOWN	4'-6"	--
PH1	#11	10	BNT.	AS SHOWN	42'-2"	--
PH2	#5	12	STR.	EQ. SPA.	39'-0"	--
PH3	#5	12	STR.	EQ. SPA.	14'-3" AVG.	10'-2" TO 18'-4"
PH4	#11	8	BNT.	AS SHOWN	26'-3"	--
PH5	#5	12	BNT.	EQ. SPA.	7'-11"	--
PS1	#4	8	BNT.	AS SHOWN	16'-9"	--
PT1	#5	24	STR.	12" C/C	3'-6"	--
PT2	#5	24	STR.	12" C/C	2'-2"	--
S1	#5	56	BNT.	EQ. SPA.	15'-4"	--
S2	#5	56	BNT.	EQ. SPA.	16'-4" AVG.	14'-6" TO 18'-2"
T1	#4	30	BNT.	EQ. SPA.	19'-0"	--
T2	#5	30	BNT.	EQ. SPA.	17'-1"	--
72" DRILLED SHAFTS						
DS2	W-20	2	BNT.	AS SHOWN	660'-1"	--
DV3	#11	52	STR.	AS SHOWN	24'-6"	--

- ④ 4 SETS OF 3
- ② 4 SETS OF 14
- ③ INCLUDED IN THE CONTRACT UNIT PRICE OF DRILLED SHAFT
- ④ LENGTH SHOWN DOES NOT ACCOUNT FOR SPLICES. CONTRACTOR MAY ADD SPLICES AS NECESSARY. BUT PAYMENT WILL NOT BE MADE FOR EXTRA LENGTH REQUIRED FOR SPLICES.
- ▲ NON-EPOXY COATED

MARK	SIZE	NO.	FORM	SPACING	LENGTH	VARIANCE
CT1	#5	90	BNT.	4" C/C	17'-1"	--
CT2	#4	180	BNT.	4" C/C	3'-6"	--
CV1	#8	56	STR.	AS SHOWN	20'-6"	--
DS1	W-20	2	BNT.	AS SHOWN	362'-5"	--
DV1	#8	80	STR.	AS SHOWN	4'-6"	--
DV2	#8	56	STR.	AS SHOWN	12'-6"	--
P1	#4	10	BNT.	EQ. SPA.	7'-5"	--
P2	#4	12	BNT.	EQ. SPA.	6'-9"	--
P3	#4	15	BNT.	EQ. SPA.	8'-5"	--
P4	#4	18	BNT.	EQ. SPA.	7'-9"	--
PE1	#4	8	BNT.	AS SHOWN	5'-11"	--
PE2	#4	10	BNT.	AS SHOWN	4'-6"	--
PH1	#11	10	BNT.	AS SHOWN	42'-2"	--
PH2	#5	12	STR.	EQ. SPA.	39'-0"	--
PH3	#5	12	STR.	EQ. SPA.	14'-3" AVG.	10'-2" TO 18'-4"
PH4	#11	8	BNT.	AS SHOWN	26'-3"	--
PH5	#5	12	BNT.	EQ. SPA.	7'-11"	--
PS1	#4	8	BNT.	AS SHOWN	16'-9"	--
PT1	#5	24	STR.	12" C/C	3'-6"	--
PT2	#5	24	STR.	12" C/C	2'-2"	--
S1	#5	56	BNT.	EQ. SPA.	15'-4"	--
S2	#5	56	BNT.	EQ. SPA.	16'-4" AVG.	14'-6" TO 18'-2"
T1	#4	30	BNT.	EQ. SPA.	19'-0"	--
T2	#5	30	BNT.	EQ. SPA.	17'-1"	--
72" DRILLED SHAFTS						
DS2	W-20	2	BNT.	AS SHOWN	789'-5"	--
DV3	#11	52	STR.	AS SHOWN	28'-6"	--

MARK	SIZE	NO.	FORM	SPACING	LENGTH	VARIANCE
CT1	#5	96	BNT.	4" C/C	17'-1"	--
CT2	#4	192	BNT.	4" C/C	3'-6"	--
CV3	#8	56	STR.	AS SHOWN	21'-6"	--
DS1	W-20	2	BNT.	AS SHOWN	362'-5"	--
DV1	#8	80	STR.	AS SHOWN	4'-6"	--
DV2	#8	56	STR.	AS SHOWN	12'-6"	--
P1	#4	10	BNT.	EQ. SPA.	7'-5"	--
P2	#4	12	BNT.	EQ. SPA.	6'-9"	--
P3	#4	15	BNT.	EQ. SPA.	8'-5"	--
P4	#4	18	BNT.	EQ. SPA.	7'-9"	--
PE1	#4	8	BNT.	AS SHOWN	5'-11"	--
PE2	#4	10	BNT.	AS SHOWN	4'-6"	--
PH1	#11	10	BNT.	AS SHOWN	42'-2"	--
PH2	#5	12	STR.	EQ. SPA.	39'-0"	--
PH3	#5	12	STR.	EQ. SPA.	14'-3" AVG.	10'-2" TO 18'-4"
PH4	#11	8	BNT.	AS SHOWN	26'-3"	--
PH5	#5	12	BNT.	EQ. SPA.	7'-11"	--
PS1	#4	8	BNT.	AS SHOWN	16'-9"	--
PT1	#5	24	STR.	12" C/C	3'-6"	--
PT2	#5	24	STR.	12" C/C	2'-2"	--
S1	#5	56	BNT.	EQ. SPA.	15'-4"	--
S2	#5	56	BNT.	EQ. SPA.	16'-4" AVG.	14'-6" TO 18'-2"
T1	#4	30	BNT.	EQ. SPA.	19'-0"	--
T2	#5	30	BNT.	EQ. SPA.	17'-1"	--
72" DRILLED SHAFTS						
DS2	W-20	2	BNT.	AS SHOWN	883'-9"	--
DV3	#11	52	STR.	AS SHOWN	31'-6"	--

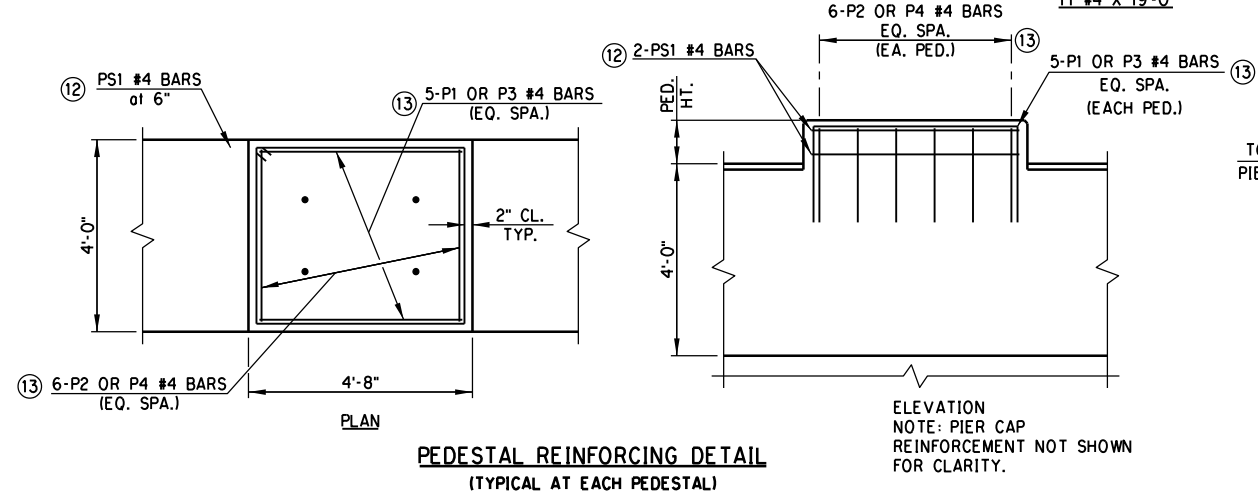

- ⑫ 3-PS1 #4 BARS REQUIRED FOR PED. HT. GREATER THAN 12".
2-PS1 #4 BARS REQUIRED FOR PED. HTS. BETWEEN 12" AND 6".
1-PS1 #4 BAR REQUIRED FOR PED. HT. LESS THAN 6".
- ⑬ P3 #4 AND P4 #4 BARS REQUIRED FOR PED. HTS. GREATER THAN 9".
P1 #4 AND P2 #4 BARS REQUIRED FOR THE REMAINING PEDESTALS.

DESIGN		BRIDGE "C"	OKLAHOMA COUNTY
DRAWN		RAMP "1" OVER 1-35	
CHECKED			
APPROVED			
SQUAD	POE	PIER DETAILS (SHEET 3 OF 3)	
		STATE JOB NO. 09032(08)	SHEET NO. B079

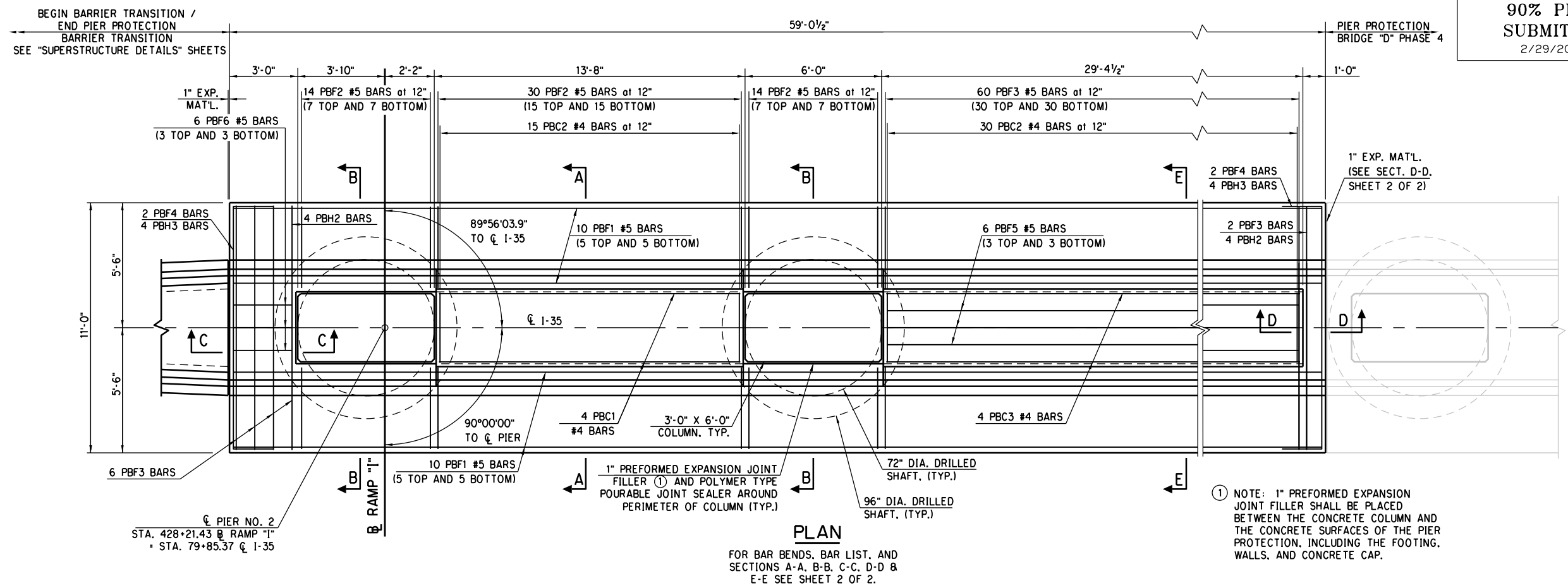

PLAN
 FOR BAR BENDS, BAR LIST, AND SECTIONS A-A, B-B, C-C, D-D & E-E SEE SHEET 2 OF 2.

① NOTE: 1" PREFORMED EXPANSION JOINT FILLER SHALL BE PLACED BETWEEN THE CONCRETE COLUMN AND THE CONCRETE SURFACES OF THE PIER PROTECTION, INCLUDING THE FOOTING, WALLS, AND CONCRETE CAP.

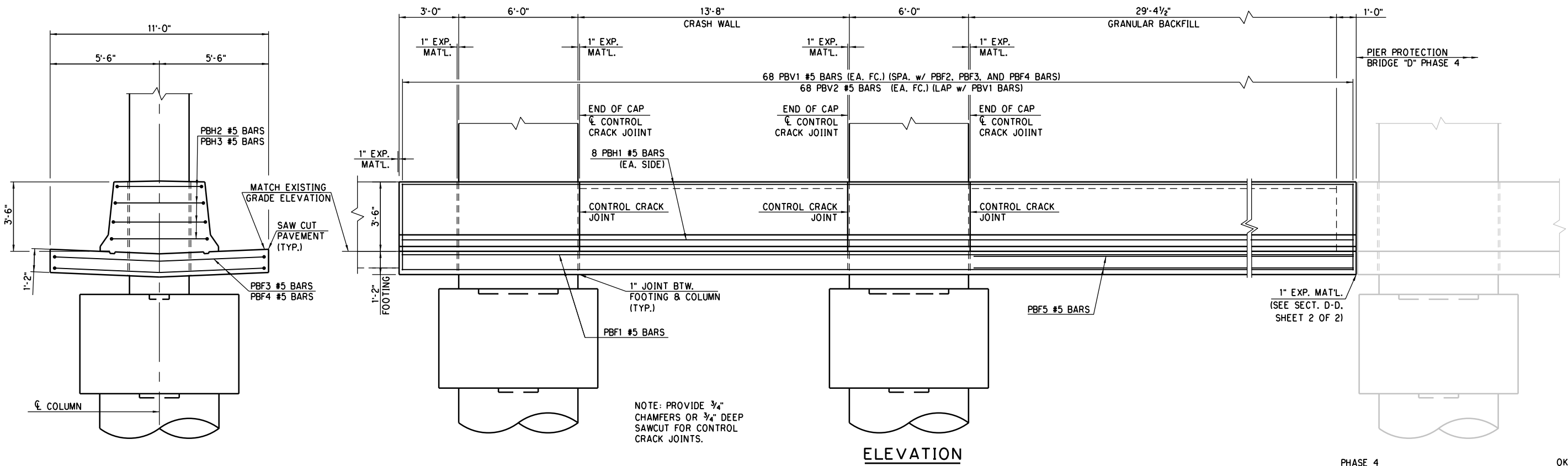

ELEVATION

NOTE: PROVIDE 3/4" CHAMFERS OR 3/4" DEEP SAWCUT FOR CONTROL CRACK JOINTS.

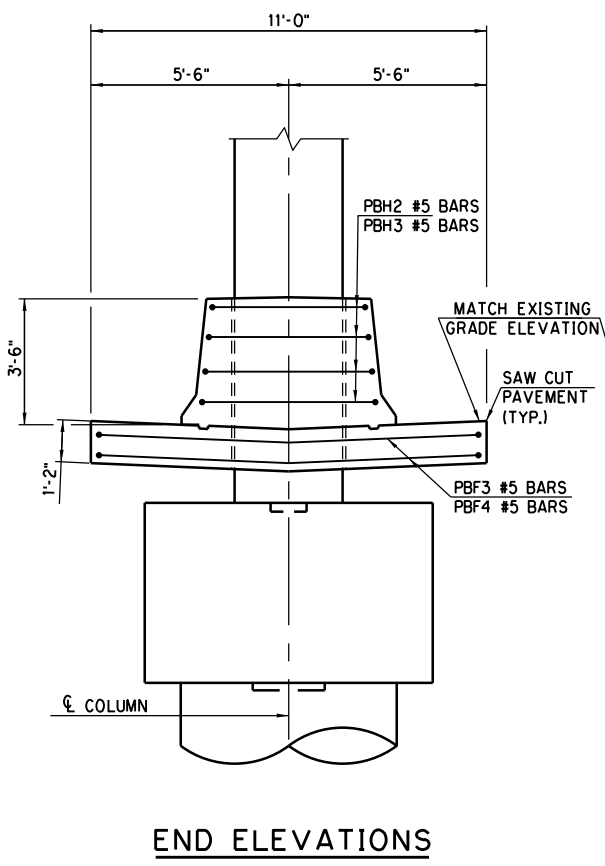

END ELEVATIONS

DESIGN		PHASE 4	OKLAHOMA COUNTY
DRAWN		BRIDGE "C"	RAMP "1" AT I-35 & I-240 INTERCHANGE
CHECKED		PIER PROTECTION DETAILS PIER NO. 2 (SHEET 1 OF 2)	
APPROVED			
SQUAD	POE		
		STATE JOB NO. 09032108	SHEET NO. B080

3/1/2024 2:43:56 PM H:\PROJECTS\2789_CrossRoads_Phase 4\Bridges\Drawings\Ph4 Bridges\Bridges\0903208 P4 Bridge C Pier Protection.dgn

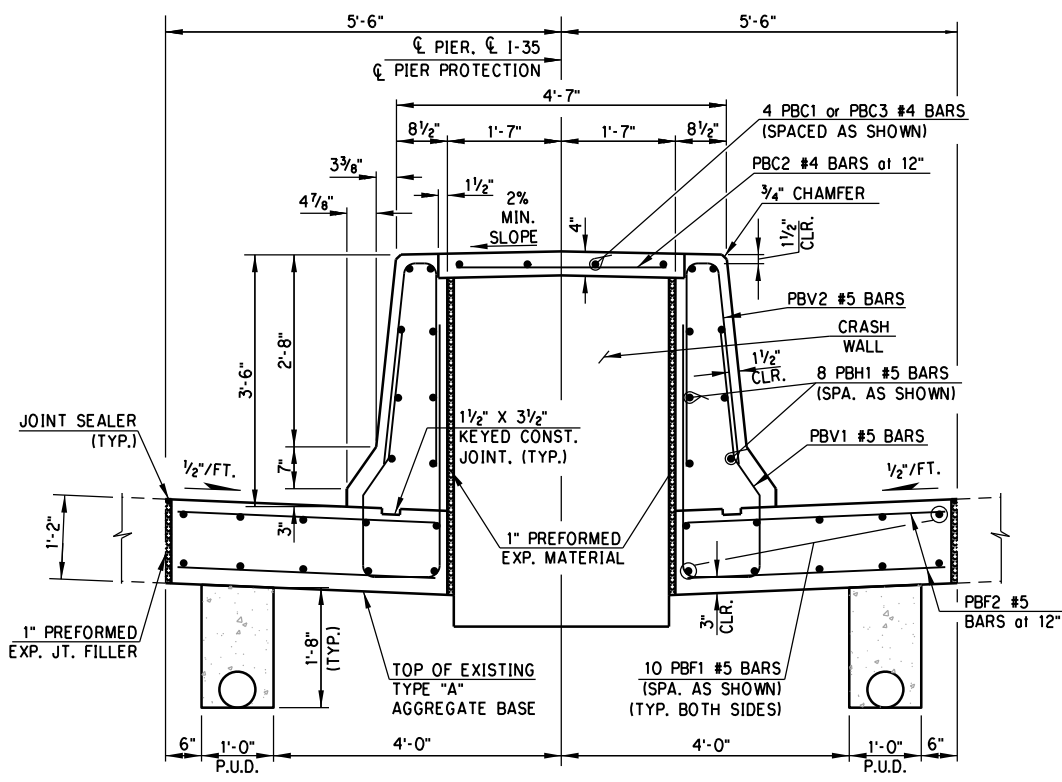

SECTION A-A
AT CRASH WALL

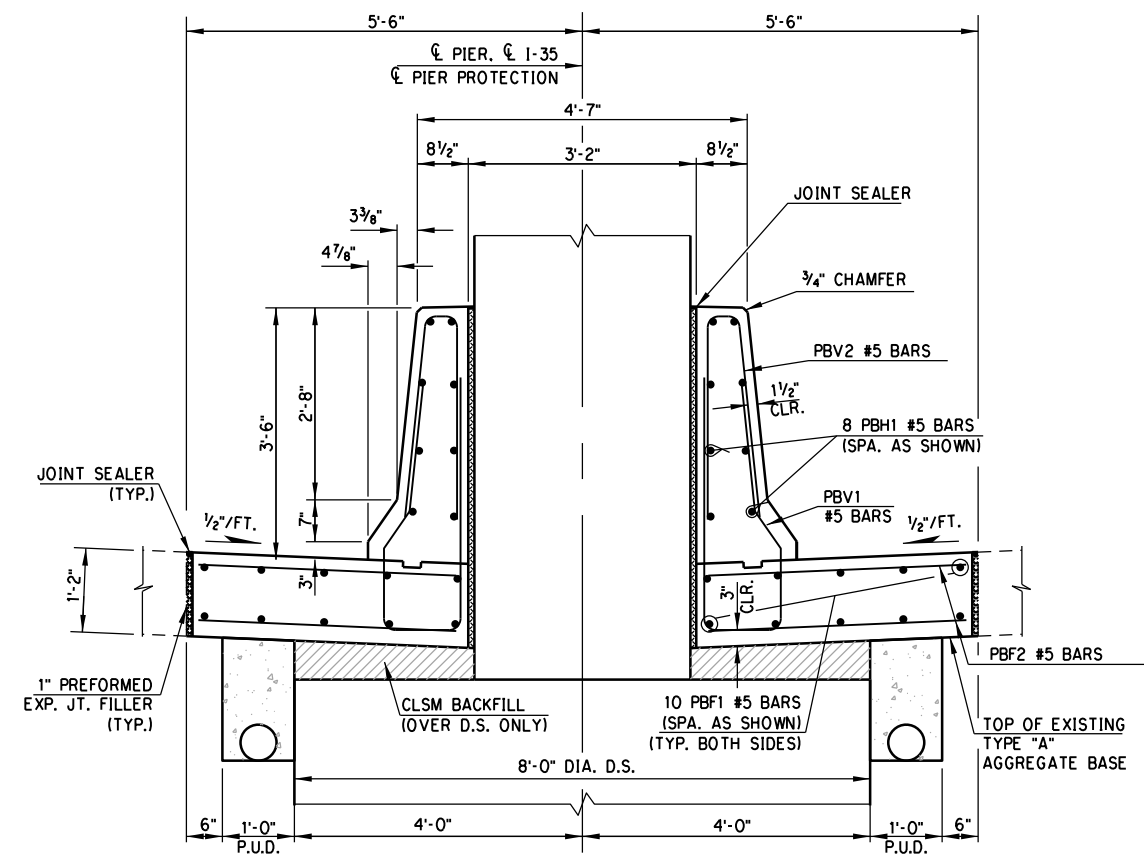

SECTION B-B
AT PIER

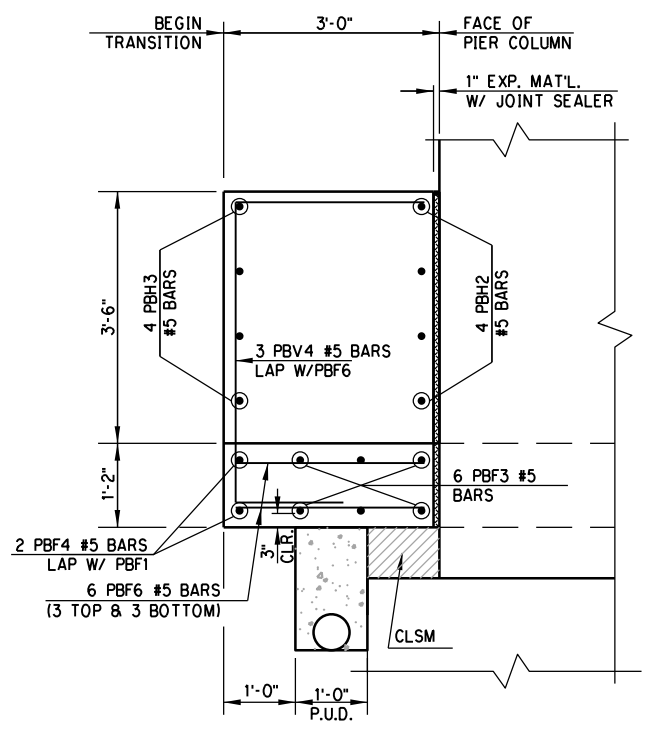

SECTION C-C
AT NORTH END

NOTE: BARRIER TRANSITION AND COLUMN REINFORCEMENT NOT SHOWN FOR CLARITY.

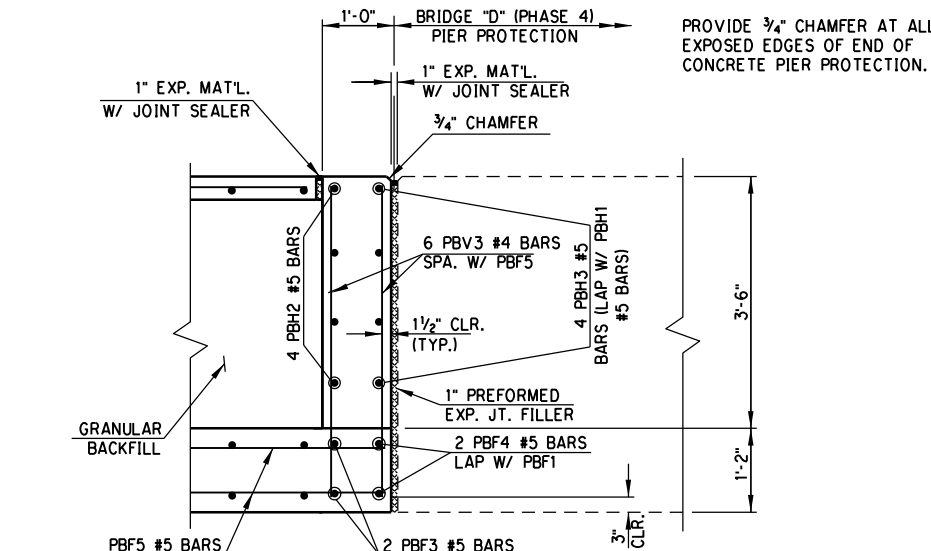

SECTION D-D
AT SOUTH END

NOTE: BARRIER TRANSITION AND COLUMN REINFORCEMENT NOT SHOWN FOR CLARITY.

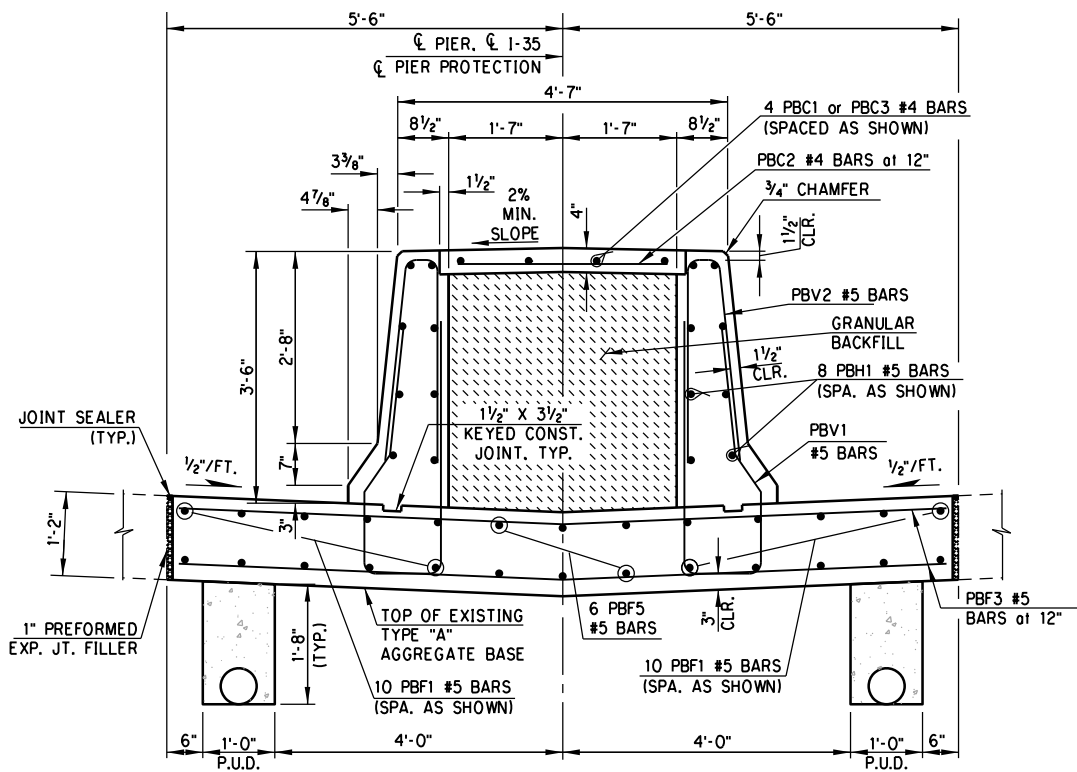

SECTION E-E
BETWEEN BRIDGE "C" & "D"

BAR LIST						
EPOXY COATED						
MARK	NO.	SIZE	FORM	SPACING	LENGTH	LENGTH VARIATION
PBC1	4	#4	STR.	AS SHOWN	13'-2"	--
PBC2	45	#4	STR.	12" C/C	3'-2"	--
PBC3	4	#4	STR.	AS SHOWN	28'-10"	--
PBF1	20	#5	STR.	AS SHOWN	58'-8"	--
PBF2	116	#5	STR.	AS SHOWN	3'-6"	--
PBF3	68	#5	STR.	12" C/C	10'-6"	--
PBF4	4	#5	BNT.	AS SHOWN	14'-0"	--
PBF5	6	#5	STR.	AS SHOWN	29'-8"	--
PBF6	6	#5	STR.	AS SHOWN	2'-7"	--
PBH1	16	#5	STR.	AS SHOWN	59'-8"	--
PBH2	8	#5	STR.	AS SHOWN	4'-6" AVG.	4'-3" TO 4'-9"
PBH3	8	#5	BNT.	AS SHOWN	8'-0" AVG.	7'-9" TO 8'-3"
PBV1	136	#5	BNT.	AS SHOWN	8'-2"	--
PBV2	136	#5	BNT.	AS SHOWN	6'-1"	--
PBV3	6	#4	STR.	AS SHOWN	4'-3"	--
PBV4	3	#5	BNT.	AS SHOWN	8'-4"	--

QUANTITIES		
ITEM	UNIT	TOTAL
CLASS A CONCRETE	C.Y.	42.40
EPOXY COATED REINFORCING STEEL	LB.	6,030.00

NOTE: COST OF SAWCUTTING, REMOVAL OF EXISTING PIER PROTECTION & MEDIAN BARRIER, PAVEMENT REMOVAL, EXCAVATION, GRANULAR BACKFILL, APPROXIMATELY 3.5 C.Y. OF CLSM BACKFILL, JOINT FILLER AND JOINT SEALER ARE INCLUDED IN OTHER ITEMS OF WORK.

DESIGN		PHASE 4	OKLAHOMA COUNTY
DRAWN		BRIDGE "C"	RAMP "I" AT I-35 & I-240 INTERCHANGE
CHECKED		PIER PROTECTION DETAILS	
APPROVED			
SQUAD	POE	PIER NO. 2	(SHEET 2 OF 2)
		STATE JOB NO. 09032(08)	SHEET NO. B081

3/1/2024 2:43:57 PM H:\PROJECTS\2789_CrossRoads_Phase 4\Bridges\Drawings\Phase 4\Bridges\Drawings\Phase 4 Bridge C Pier Protection.dgn

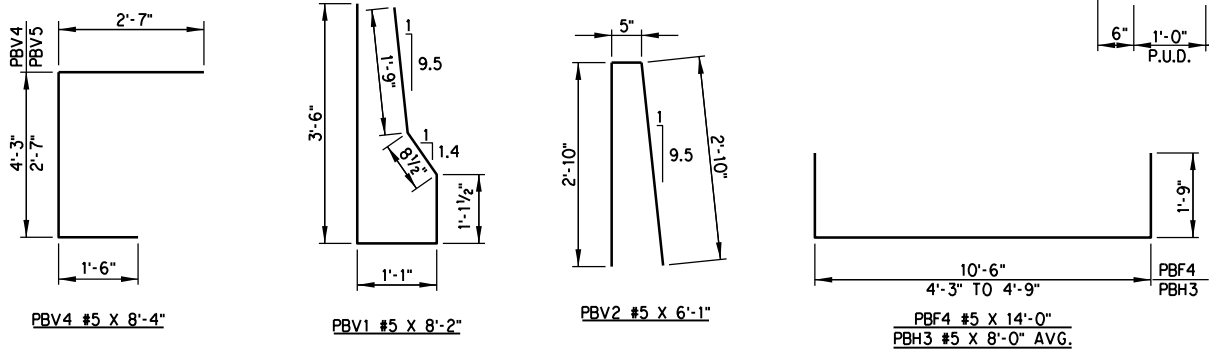

BENT BAR DIMENSIONS ARE OUT TO OUT

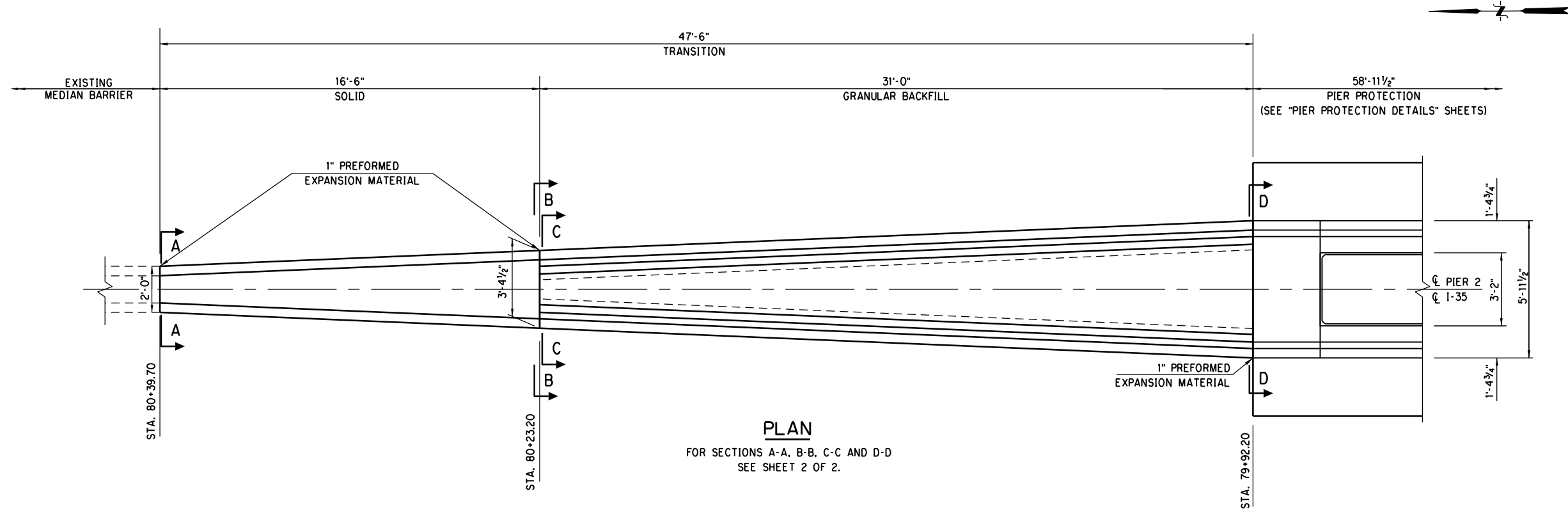

PLAN
FOR SECTIONS A-A, B-B, C-C AND D-D
SEE SHEET 2 OF 2.

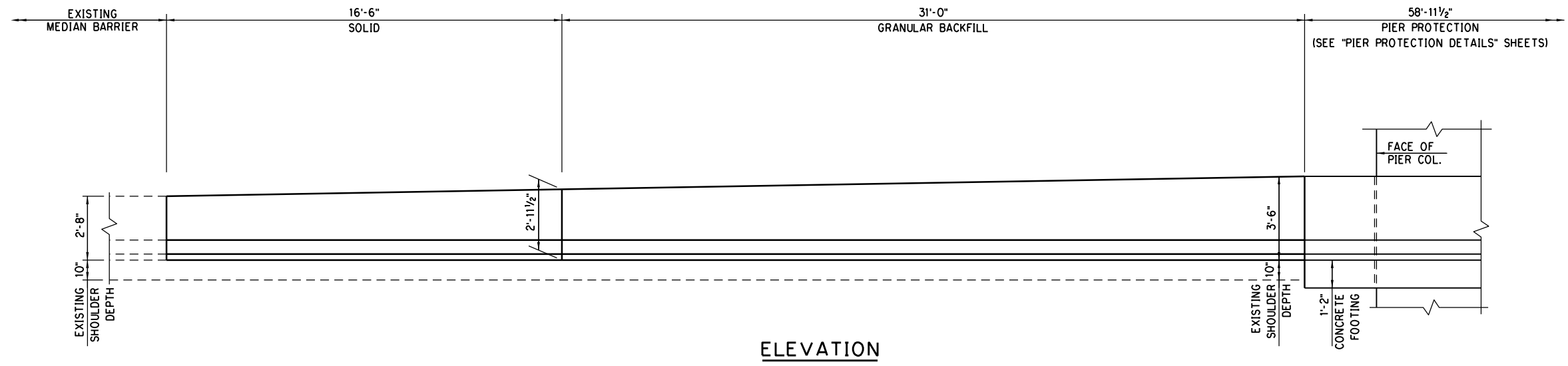

ELEVATION

3/1/2024 2:44:42 PM H:\PROJECTS\2789_CrossRoads_Phase 4\Bridges\Drawings\Ph4 Bridges\Bridges\0903208 P4 Bridge C Pier Protection Transition.dgn

DESIGN		PHASE 4		OKLAHOMA COUNTY	
DRAWN		BRIDGE "C"		RAMP "1" AT I-35 & I-240 INTERCHANGE	
CHECKED		BARRIER TRANSITION DETAILS			
APPROVED					
SQUAD		POE		PIER NO. 2 (SHEET 1 OF 2)	
				STATE JOB NO. 09032(08) SHEET NO. B082	

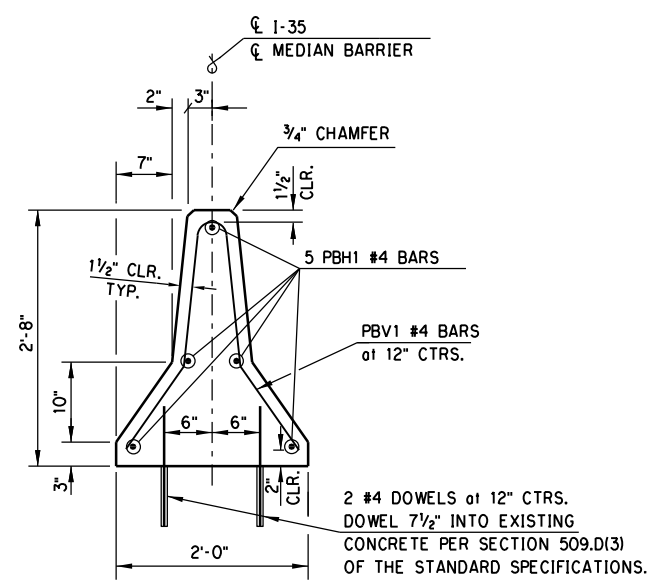

SECTION A-A
AT BEGIN SOLID TRANSITION

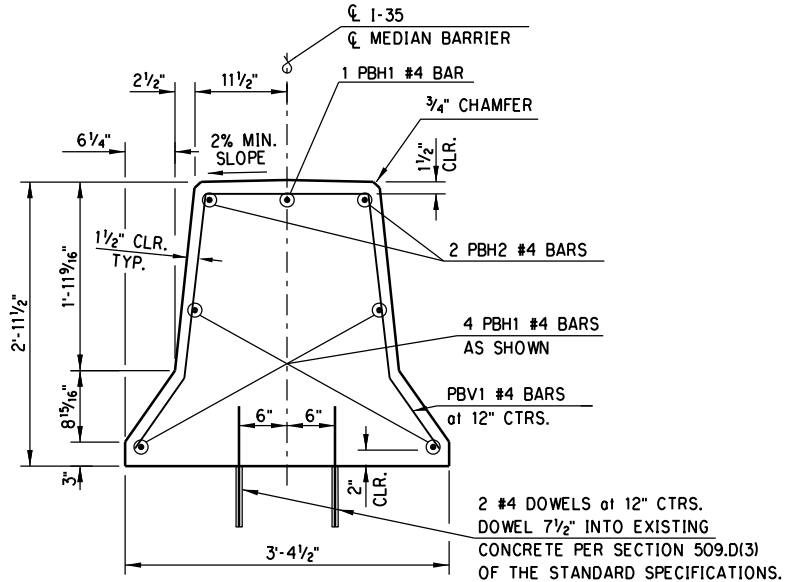

SECTION B-B
AT END SOLID TRANSITION

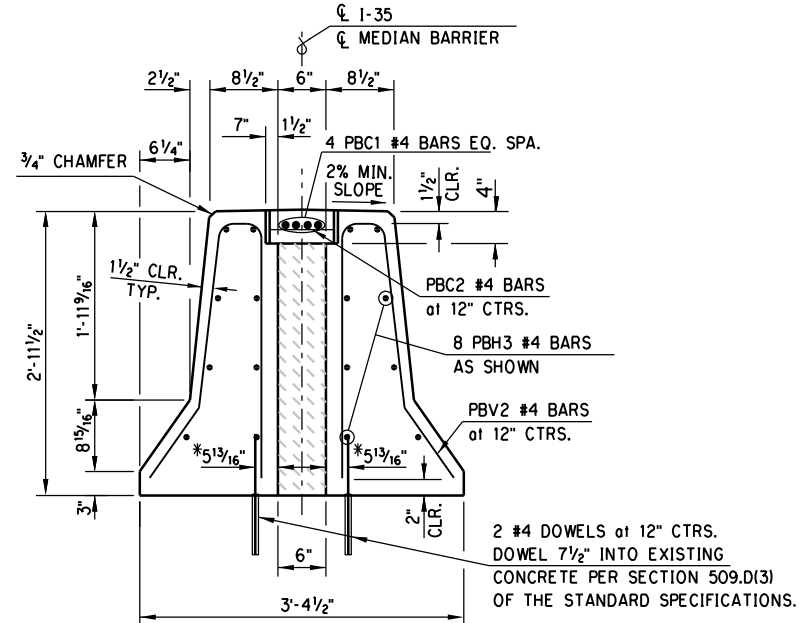

SECTION C-C
AT BEGIN GRANULAR BACKFILLED TRANSITION

* NOTE: AN EXPANSION JOINT IS LOCATED 12" FROM C 1-35.
MAINTAIN 6" CLEARANCE WHEN INSTALLING DOWELS FROM
STATION 79+92.20 TO 80+39.70

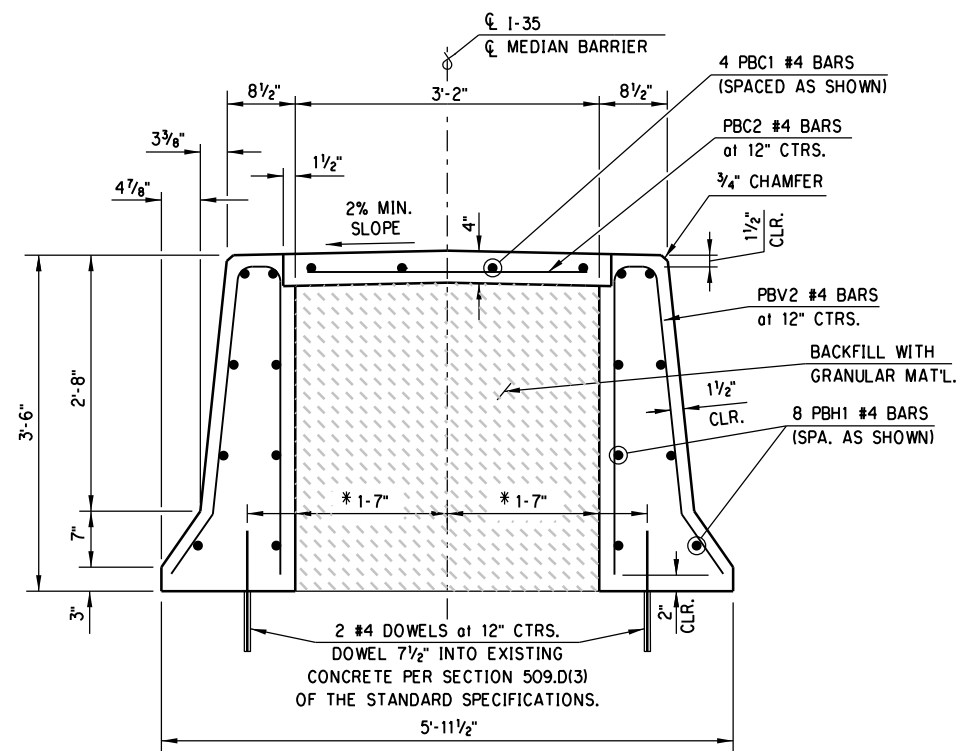

SECTION D-D
AT END GRANULAR BACKFILLED TRANSITION

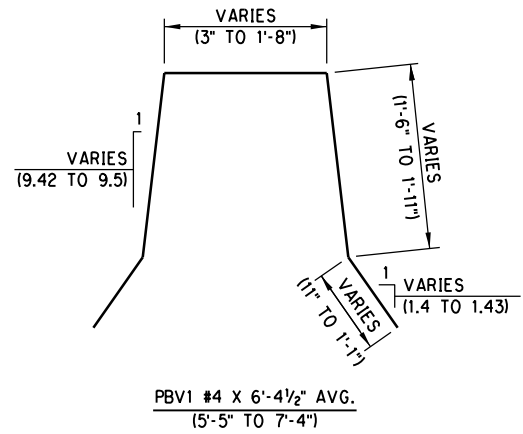

PBV1 #4 X 6'-4 1/2" AVG.
(5'-5" TO 7'-4")

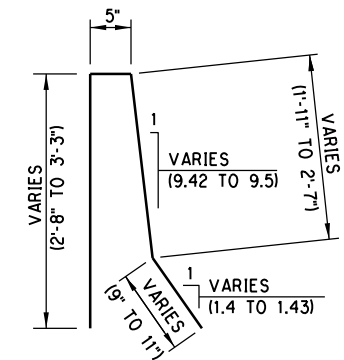

PBV2 #4 X 6'-5 1/2" AVG.
(5'-11" TO 7'-0")

BENT BAR DIMENSIONS ARE OUT TO OUT

BAR LIST EPOXY COATED						
MARK	NO.	SIZE	FORM	SPACING	LENGTH	LENGTH VARIATION
PBC1	4	#4	STR.	AS SHOWN	30'-8"	--
PBC2	32	#4	STR.	12" C/C	2'-11"	--
PBH1	5	#4	STR.	AS SHOWN	16'-2"	--
PBH2	2	#4	STR.	AS SHOWN	8'-3"	--
PBH3	16	#4	STR.	AS SHOWN	30'-8"	--
PBV1	17	#4	BNT.	12" C/C	6'-4 1/2" AVG.	5'-5" TO 7'-4"
PBV2	32	#4	BNT.	12" C/C	6'-5 1/2" AVG.	5'-11" TO 7'-0"

QUANTITIES		
ITEM	UNIT	TOTAL
CLASS A CONCRETE	C.Y.	10.80
EPOXY COATED REINFORCING STEEL	LB.	750.00

DESIGN		PHASE 4	OKLAHOMA COUNTY
DRAWN		BRIDGE "C"	RAMP "I" AT I-35 & I-240 INTERCHANGE
CHECKED		BARRIER TRANSITION DETAILS	
APPROVED			
SQUAD	POE	PIER NO. 2	(SHEET 2 OF 2)
		STATE JOB NO. 09032(08)	SHEET NO. B083

3/1/2024 2:44:13 PM H:\PROJECTS\2789_CrossRoads_Phase 4\Bridges\Drawings\Ph4 Bridges\Bridges\0903208 P4 Bridge C Pier Protection Transition.dgn

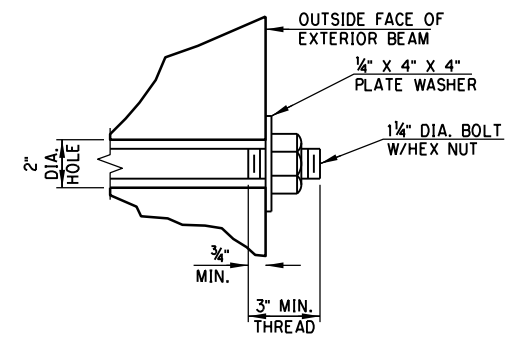
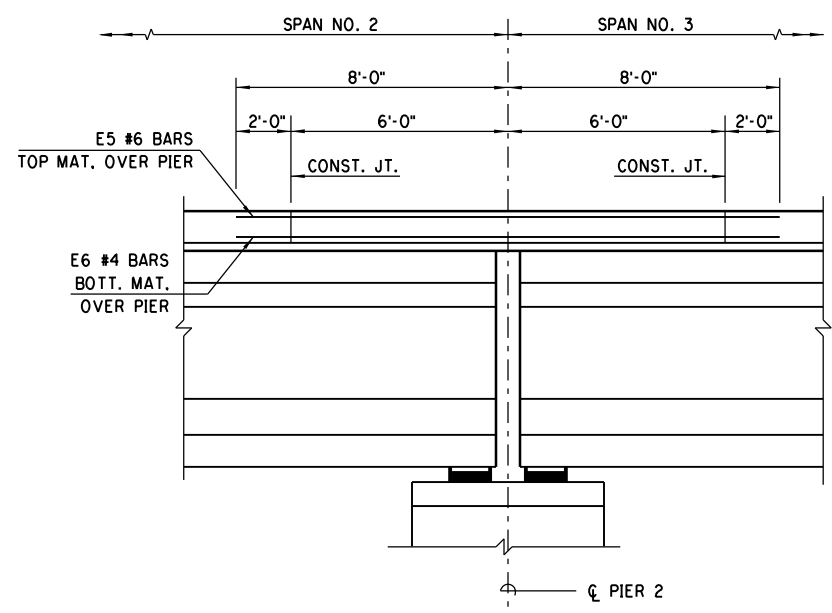
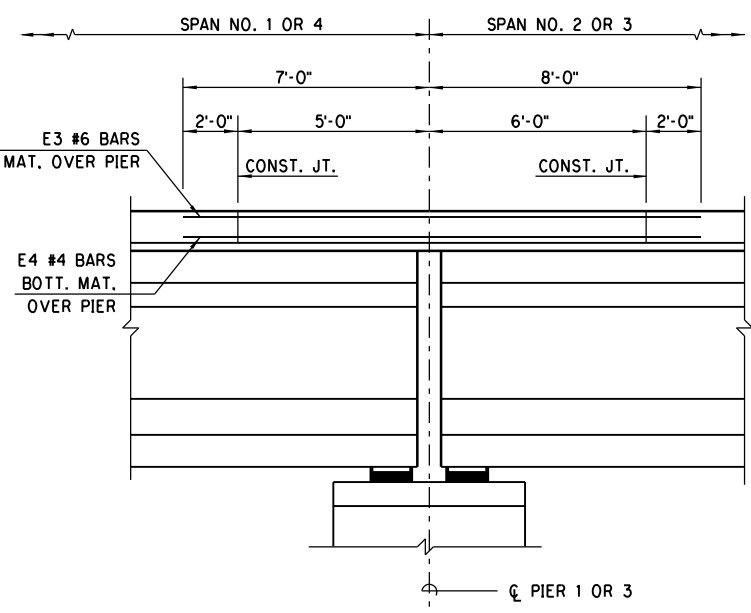
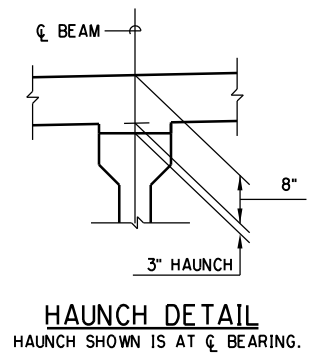
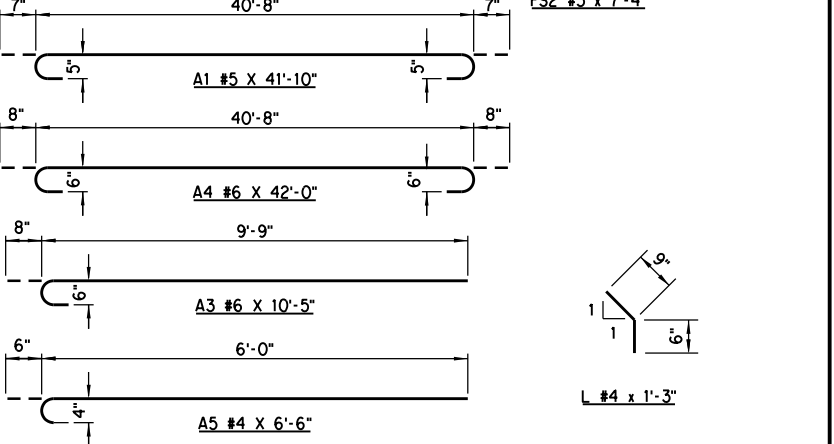
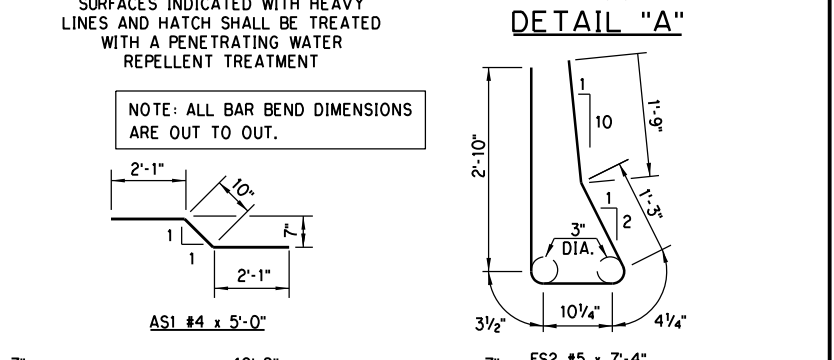
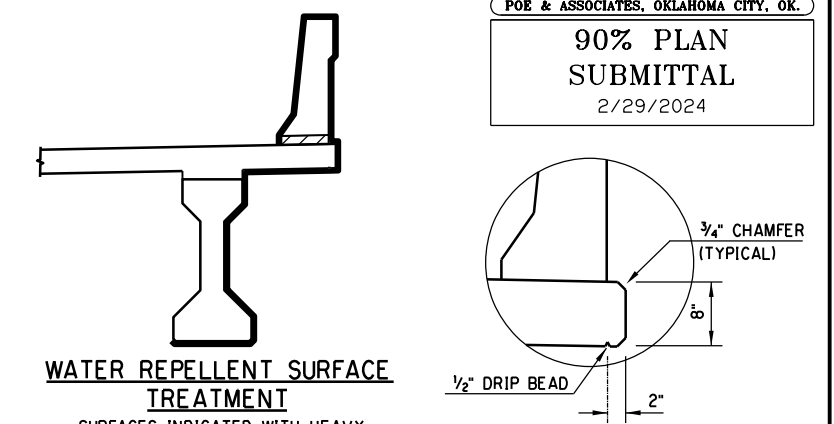
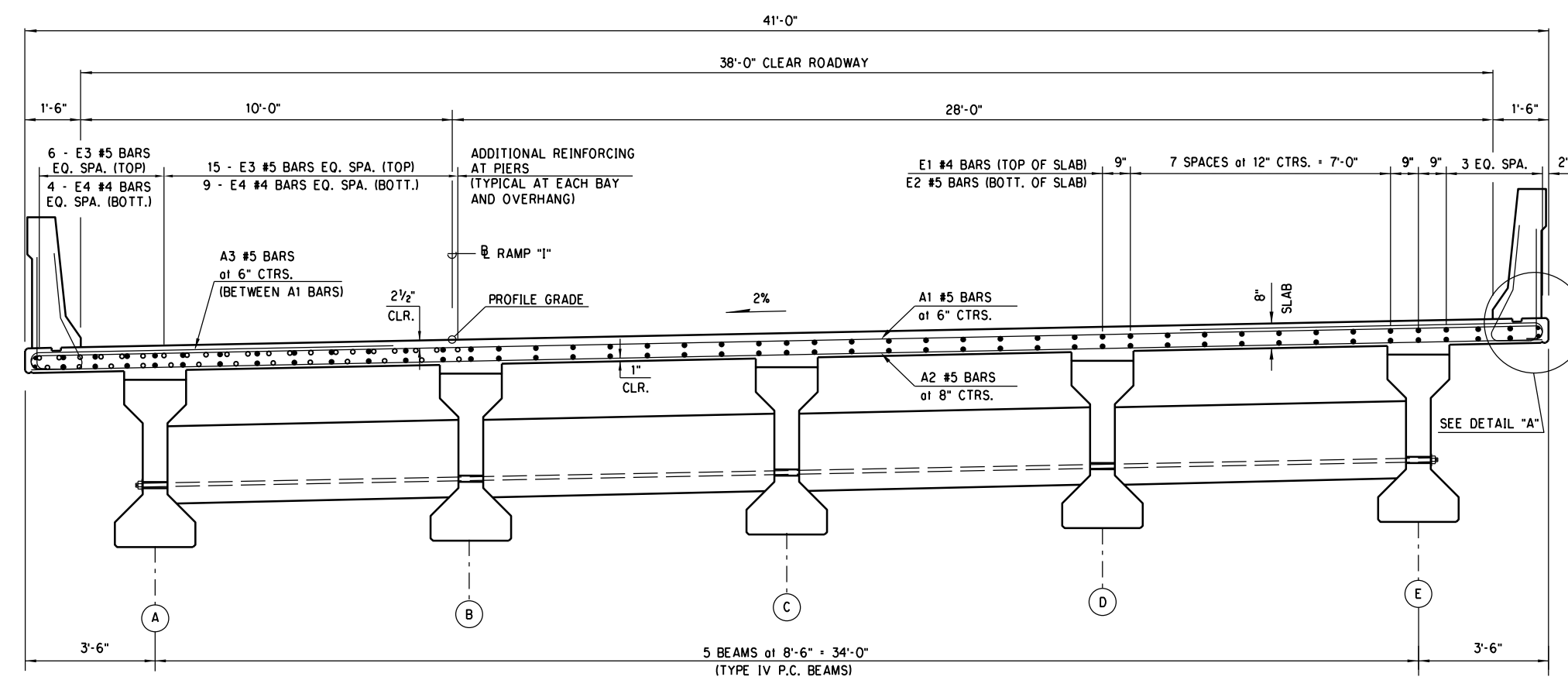

NOTE: PROVIDE STRUCTURAL STEEL FOR DIAPHRAGM BOLTS AND PLATE WASHERS IN ACCORDANCE WITH AASHTO M270 (ASTM A709), GRADE 50W (WEATHERING STEEL, CHARPY V-NOTCH TESTING NOT REQUIRED). THE CONTRACTOR MAY SUBSTITUTE A #10 REINFORCING BAR IN ACCORDANCE WITH AASHTO M31, GRADE 60, AND THREADED AT THE ENDS AS SHOWN FOR THE DIAPHRAGM BOLT AT NO ADDITIONAL COST TO THE DEPARTMENT. PROVIDE HEX NUTS IN ACCORDANCE WITH AASHTO M291 (ASTM A563). PAINT EXPOSED DIAPHRAGM BOLT, PLATE WASHER AND HEX NUT WITH TWO (2) COATS OF ZINC-RICH PAINT (6 MIL MINIMUM THICKNESS) AFTER ASSEMBLY. INCLUDE ALL COST OF DIAPHRAGM BOLT, PLATE WASHER AND HEX NUT IN THE CONTRACT UNIT PRICE FOR STRUCTURAL STEEL.

QUANTITIES		
ITEM	UNIT	TOTAL
PRESTRESSED CONC. BEAMS (TYPE IV)	L.F.	1,596.34
SAW CUT GROOVING	S.Y.	1,353.20
42" F-SHAPED PARAPET	L.F.	641.00
STRUCTURAL STEEL	LB.	1,540.00
STAINLESS STEEL FIXED BEARING ASSEMBLY	EA.	10.00
STAINLESS STEEL EXPANSION BEARING ASSEMBLY	EA.	30.00
** CLASS AA CONCRETE	C.Y.	396.30
EPOXY COATED REINFORCING STEEL	LB.	109.00
WATER REPELLENT (VISUALLY INSPECTED)	S.Y.	1,485.00
SEALER CRACK PREPARATION	L.F.	228.00
SEALER RESIN	GAL.	3.00

** NOTE: PLAN QUANTITY FOR CLASS "AA" CONCRETE INCLUDES 12.3 C.Y. FOR HAUNCHES OVER BEAMS. THE HAUNCH HEIGHTS WILL BE SET AFTER ERECTION OF BEAMS TO PROVIDE FOR DEAD LOAD DEFLECTION AND GRADE ADJUSTMENT, BUT THE PAY QUANTITY FOR HAUNCHES WILL BE AS SHOWN ABOVE.

FOR SLAB LAYOUT, SEE SHEET 3 OF 3. FOR LONGITUDINAL SECTION, SEE "LONGITUDINAL SECTION AND DIAPHRAGM DETAILS" SHEET.

DESIGN		PHASE 4	OKLAHOMA COUNTY
DRAWN		BRIDGE "C"	RAMP "I" OVER I-35
CHECKED		SUPERSTRUCTURE DETAILS (SHEET 1 OF 3)	
APPROVED			
SQUAD	POE	STATE JOB NO. 09032(08)	SHEET NO. B084

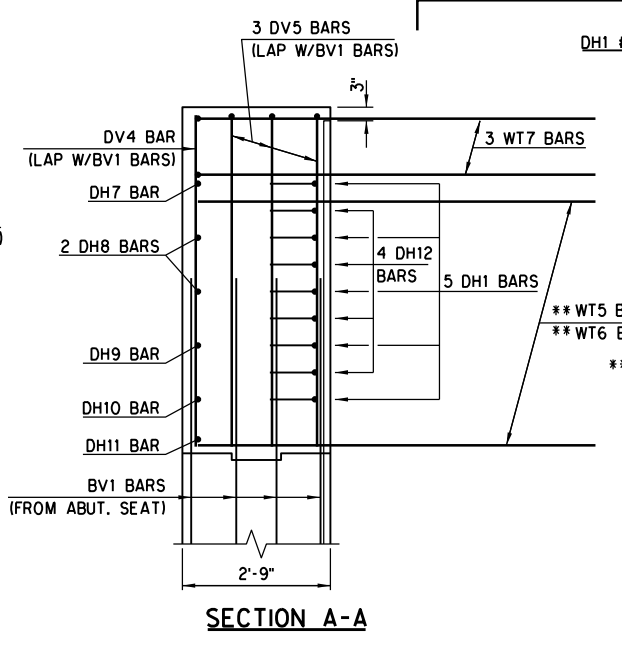
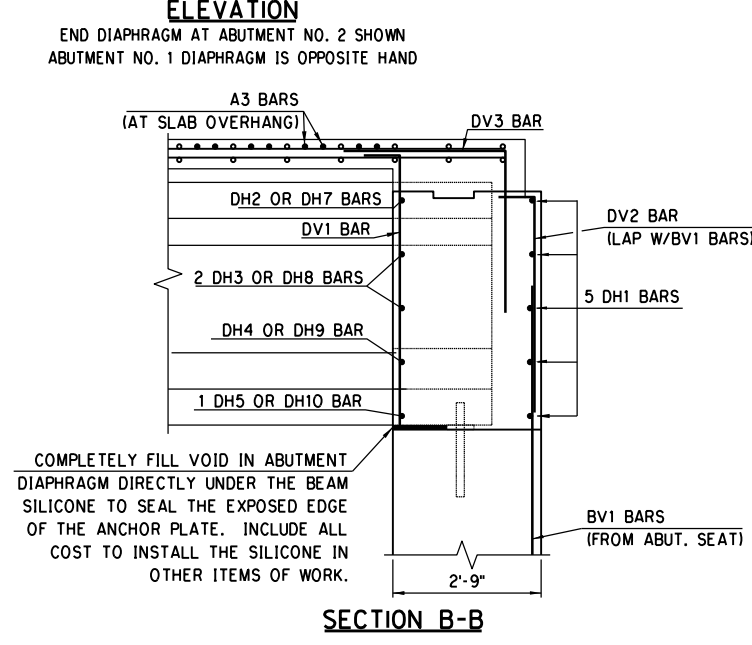
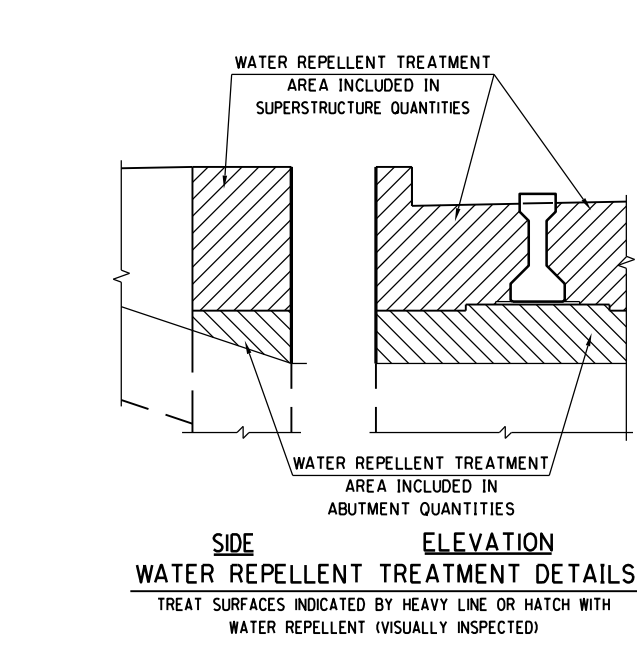
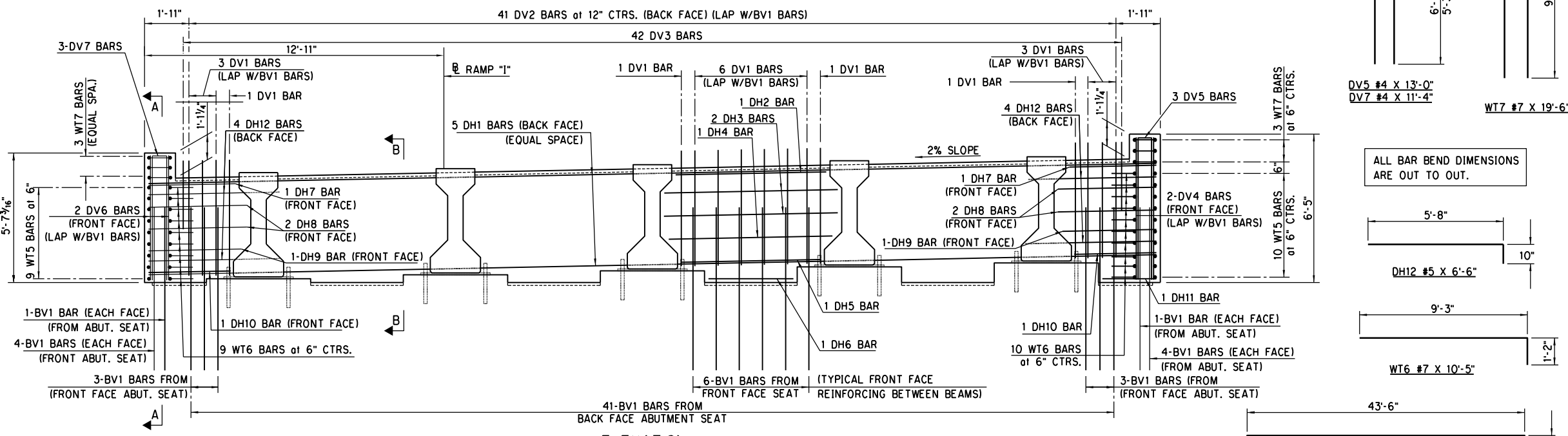
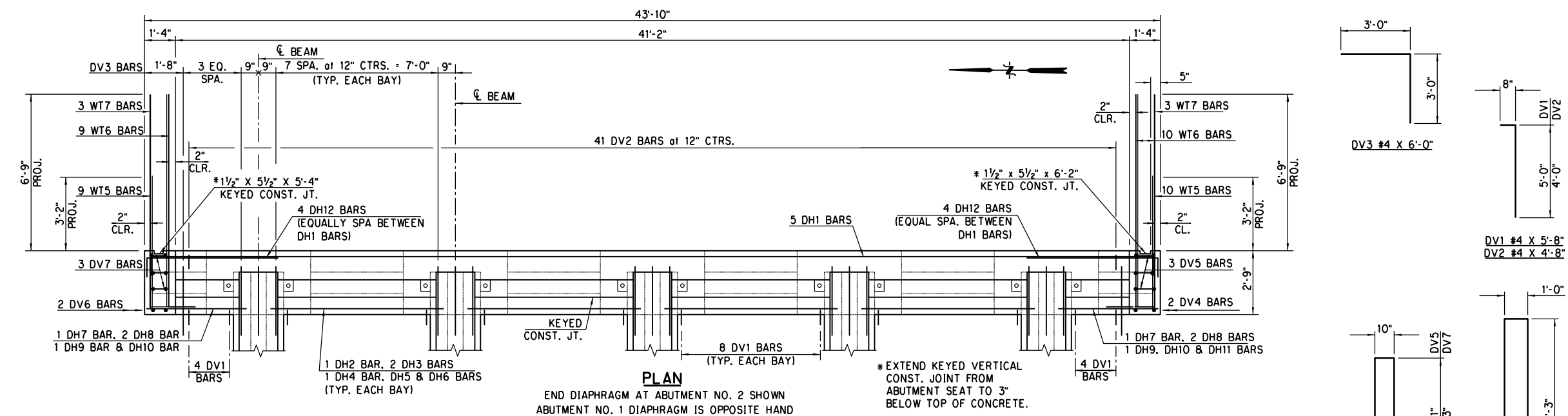

BAR LIST (EPOXY COATED)					
MARK	NO.	SIZE	FORM	SPACING	LENGTH
A1	568	#5	BNT.	6" C/C	41'-10"
A2	475	#5	STR.	8" C/C	40'-8"
A3	1128	#6	BNT.	6" C/C	10'-5"
A4	71	#6	BNT.	6" C/C	42'-0"
A5	136	#4	BNT.	6" C/C	6'-6"
A51	84	#4	BNT.	12" C/C	5'-0"
DH1	10	#5	BNT.	AS SHOWN	45'-2"
DH2	8	#5	STR.	AS SHOWN	6'-6"
DH3	16	#5	STR.	AS SHOWN	7'-6"
DH4	8	#5	STR.	AS SHOWN	6'-10"
DH5	8	#5	STR.	AS SHOWN	6'-0"
DH6	8	#5	STR.	AS SHOWN	3'-8"
DH7	4	#5	STR.	AS SHOWN	3'-9"
DH8	8	#5	STR.	AS SHOWN	4'-3"
DH9	4	#5	STR.	AS SHOWN	3'-11"
DH10	4	#5	STR.	AS SHOWN	3'-6"
DH11	2	#5	STR.	AS SHOWN	2'-4"
DH12	16	#4	BNT.	AS SHOWN	6'-6"
DV1	80	#4	BNT.	EQ. SPA.	5'-8"
DV2	82	#4	BNT.	12" C/C	4'-8"
DV3	90	#4	BNT.	AS SHOWN	6'-0"
DV4	4	#4	STR.	EQ. SPA.	6'-1"
DV5	6	#4	BNT.	EQ. SPA.	13'-0"
DV6	4	#4	BNT.	EQ. SPA.	5'-3"
DV7	6	#4	BNT.	EQ. SPA.	11'-4"
E1	45	#4	STR.	AS SHOWN	330'-4"
E2	45	#5	STR.	AS SHOWN	335'-10"
E3	144	#5	STR.	AS SHOWN	15'-0"
E4	88	#4	STR.	AS SHOWN	15'-0"
E5	72	#5	STR.	AS SHOWN	16'-0"
E6	44	#4	STR.	AS SHOWN	16'-0"
F1	240	#4	STR.	EQ. SPA.	7'-6"
FS2	624	#5	BNT.	SEE STD.	7'-4"
L	32	#4	BNT.	SEE STD.	1'-3"
UI	360	#4	BNT.	AS SHOWN	4'-9"
WT5	38	#4	STR.	6" C/C	5'-9"
WT6	38	#7	BNT.	6" C/C	10'-5"
WT7	12	#7	BNT.	6" C/C	19'-6"

① LENGTH INCLUDES LAP
E1 - 6 at 1'-8"
E2 - 6 at 12'-7"

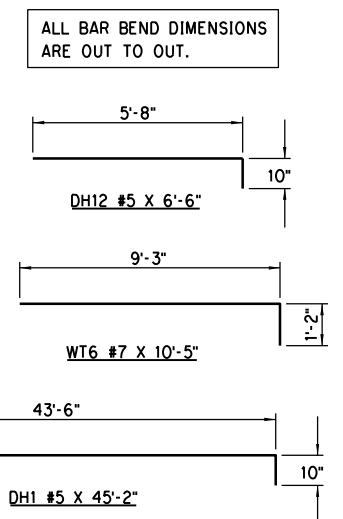

DESIGN	
DRAWN	
CHECKED	
APPROVED	
SQUAD	POE

PHASE 4
BRIDGE "C"
OKLAHOMA COUNTY
RAMP "1" OVER I-35

SUPERSTRUCTURE DETAILS
(SHEET 2 OF 3)

STATE JOB NO. 09032(08) SHEET NO. B085

3/1/2024 \$TIME\$ H:\PROJECTS\2789_CrossRoads_Phase 4\Bridges\Drawings\Ph4 Bridges\Bridges\0903208 P4 Bridge C SUPER.dgn

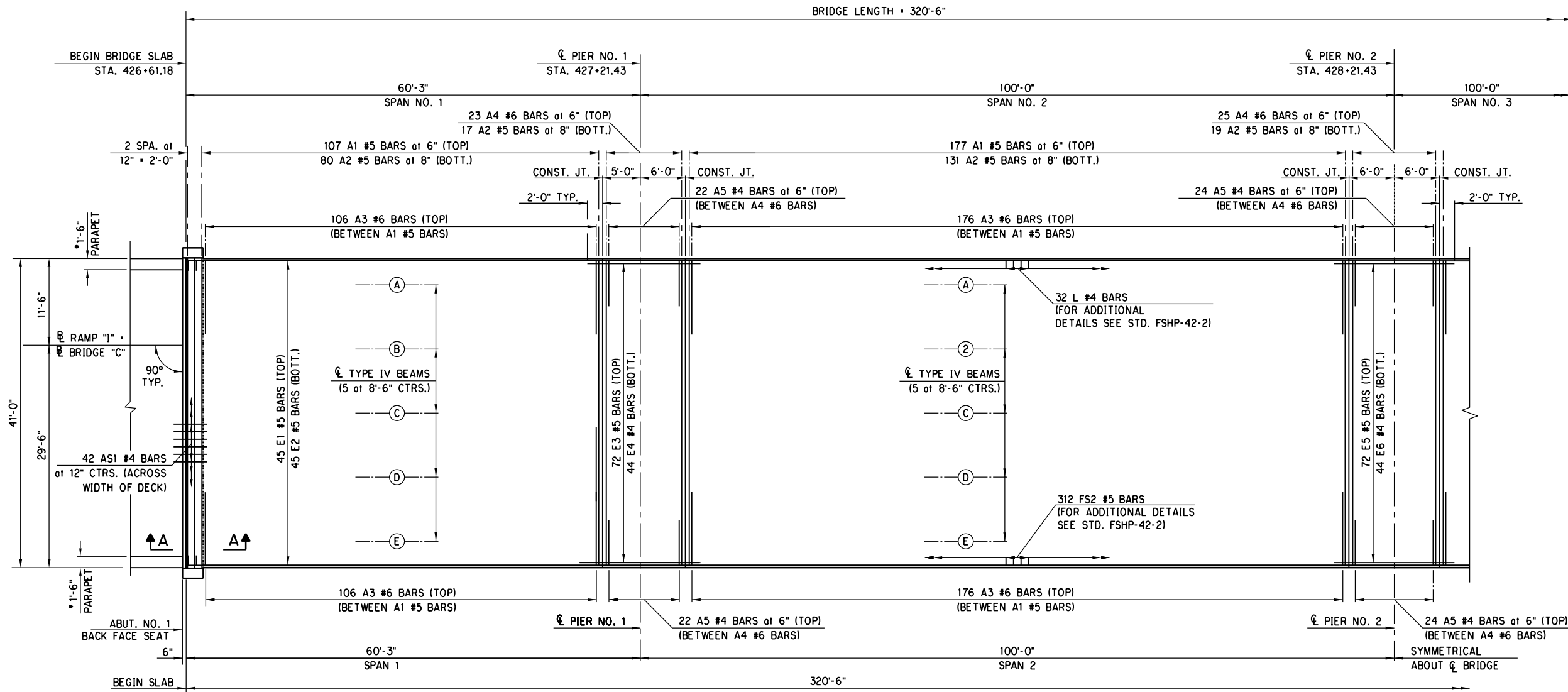
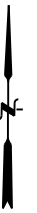

SLAB REINFORCING LAYOUT

NOTE: FOR ADDITIONAL DETAILS AT ABUTMENT DIAPHRAGM, SEE SHEET 2 OF 3.

NOTE: CONCRETE PARAPET NOT SHOWN IN LAYOUT FOR CLARITY. FOR DETAILS OF PARAPET SEE STD. FSHP-42-2.

CONSTRUCTION JOINTS (SEAL WITH HIGH MOLECULAR WEIGHT METHACRYLATE)

NOTE: SEAL TRANSVERSE CONSTRUCTION JOINTS BETWEEN INSIDE FACE OF PARAPETS.

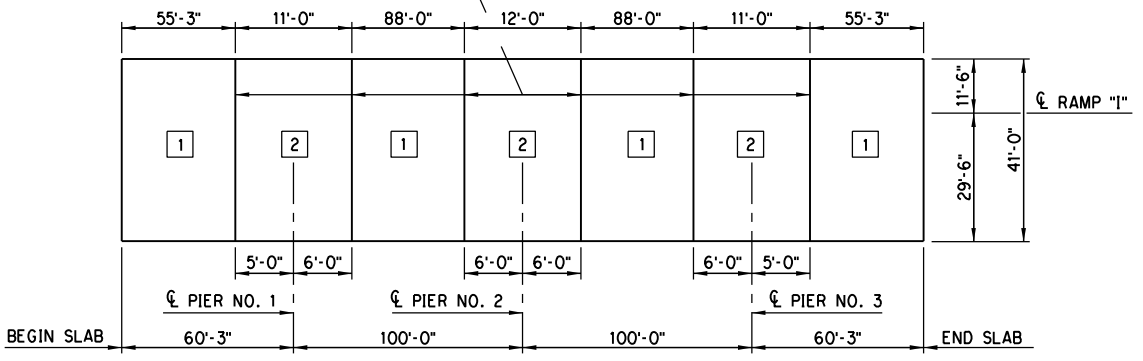

SLAB POURING SEQUENCE

DECK SLAB POURING SEQUENCE DIAGRAM NOTE

THE DECK SLAB IS DIVIDED INTO SECTIONS BETWEEN CONSTRUCTION JOINTS AS SHOWN. THE CONCRETE SHALL BE POURED IN EACH SECTION OF THE DECK SLAB IN THE NUMERICAL SEQUENCE INDICATED. SECTIONS OF THE DECK SLAB WITH THE SAME NUMBER MAY BE POURED IN ANY ORDER. UNDER NO CIRCUMSTANCES WILL SECTION IN SEQUENCE 2 BE POURED BEFORE THE ADJACENT SECTIONS HAVE BEEN IN PLACE FOR AT LEAST 48 HOURS.

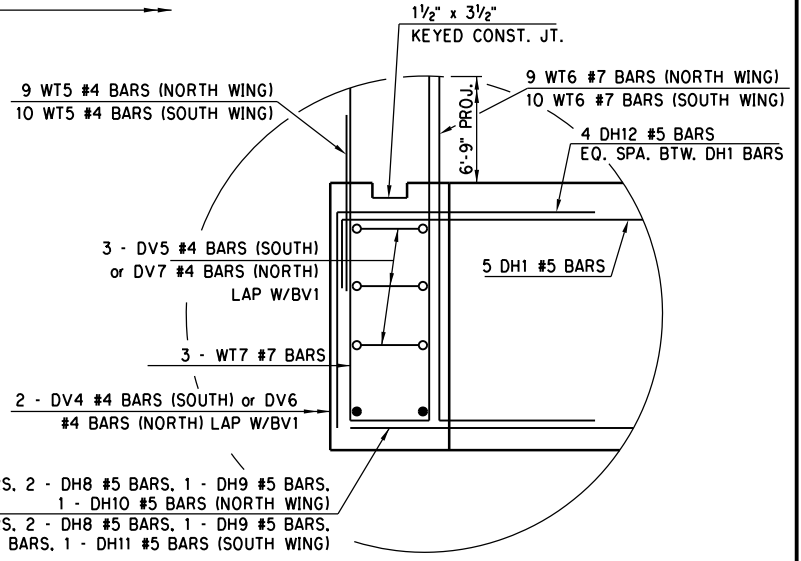

DETAIL AT EDGE

DESIGN	
DRAWN	
CHECKED	
APPROVED	
SQUAD	POE

PHASE 4
BRIDGE "C"
OKLAHOMA COUNTY
RAMP "I" OVER I-35

SUPERSTRUCTURE DETAILS
(SHEET 3 OF 3)

STATE JOB NO. 09032(08) SHEET NO. B086

3/1/2024 2:44:02 PM H:\PROJECTS\2789_CrossRoads_Phase 4\Bridges\Drawings\Ph4 Bridges\Bridges\C0903208 P4 Bridge C SUPER.dgn

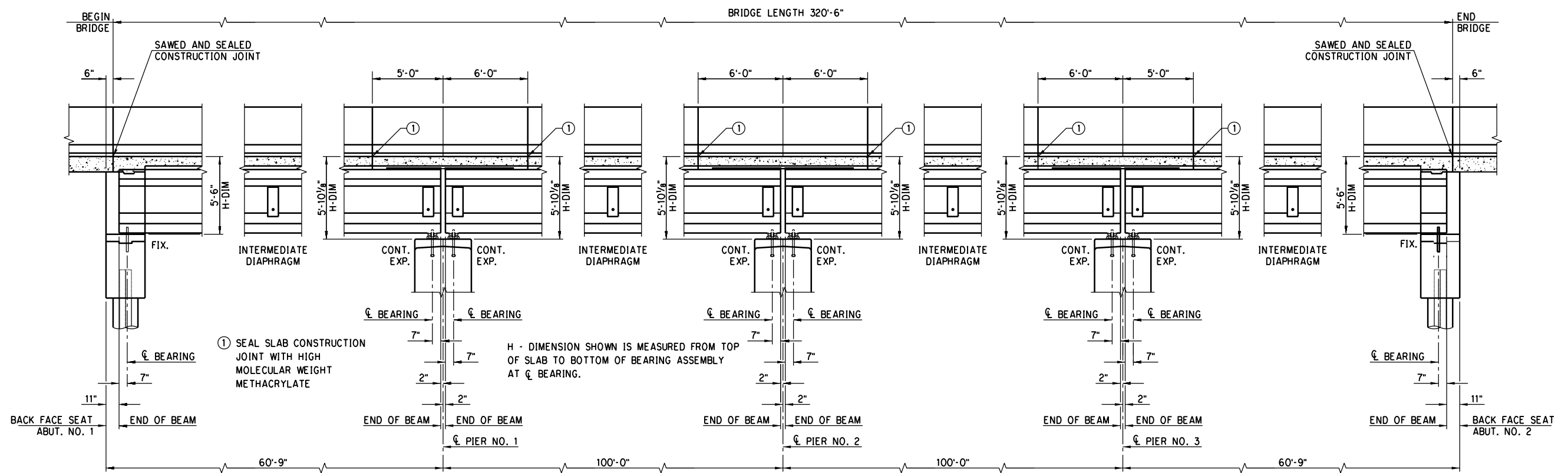

LONGITUDINAL SECTION

NOTE:
DECK SHALL NOT BE PLACED ON BEAMS
YOUNGER THAN 28 DAYS OLD.

DO NOT PLACE THE CONCRETE FOR THE DECK SLAB OR APPLY
OTHER MASSIVE LOADS TO THE BEAMS OR DIAPHRAGMS UNTIL
THE CONCRETE IN THE DIAPHRAGMS HAS BEEN IN PLACE A
MINIMUM OF 10 DAYS OR AT THE DISCRETION OF THE
ENGINEER. THIS TIME MAY BE SHORTENED IF THE CONCRETE
HAS ATTAINED 80% OF THE SPECIFIED COMPRESSIVE STRENGTH.

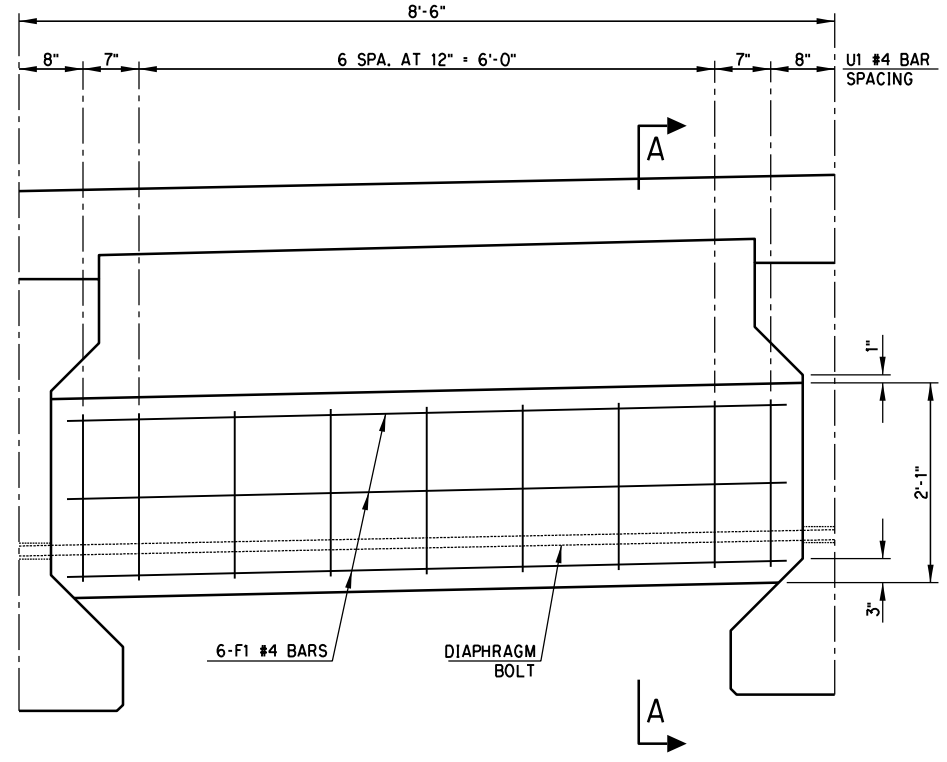

INTERMEDIATE & PIER DIAPHRAGM DETAIL

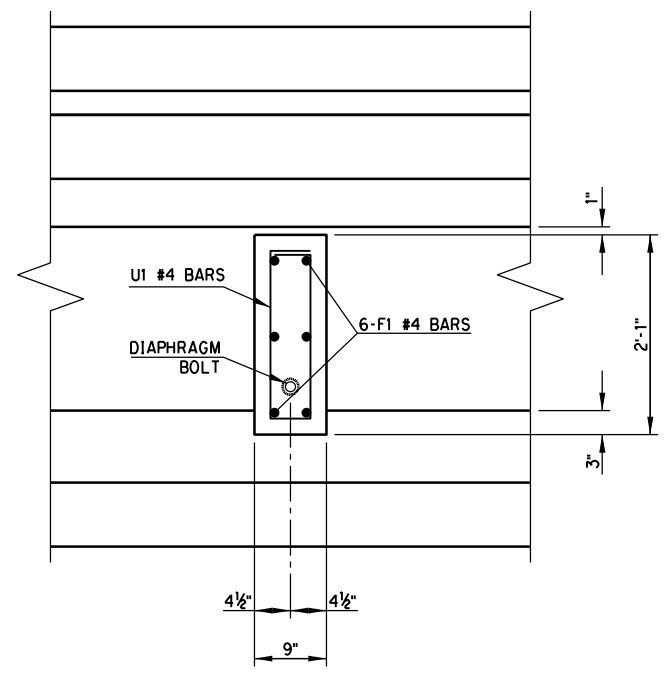

INTERMEDIATE
DIAPHRAGM

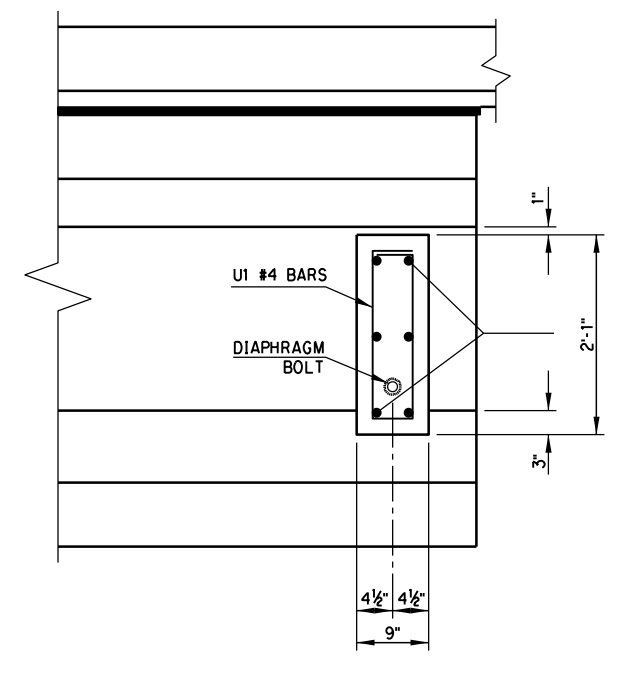

PIER
DIAPHRAGM

SECTION A-A

DESIGN	
DRAWN	
CHECKED	
APPROVED	
SQUAD	POE

PHASE 4
BRIDGE "C"
OKLAHOMA COUNTY
RAMP "I" OVER I-35

LONGITUDINAL SECTION AND
DIAPHRAGM DETAILS

STATE JOB NO. 090321081 SHEET NO. B087

3/1/2024 2:44:02 PM H:\PROJECTS\2789_CrossRoads_Phase 4 Bridge\Drawings\Ph4 Bridges\Bridges\0903208 P4 Bridge C SUPER.dgn

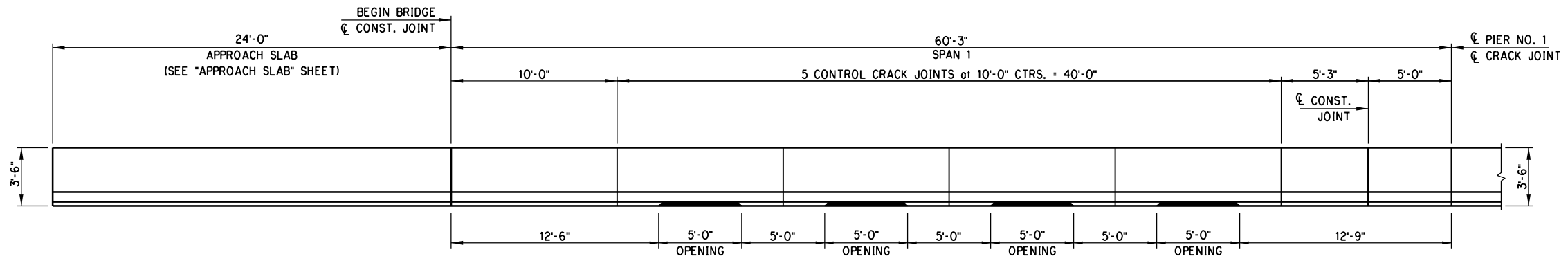

**NORTH PARAPET OPENING AND JOINT SPACING
SPAN NO. 1**

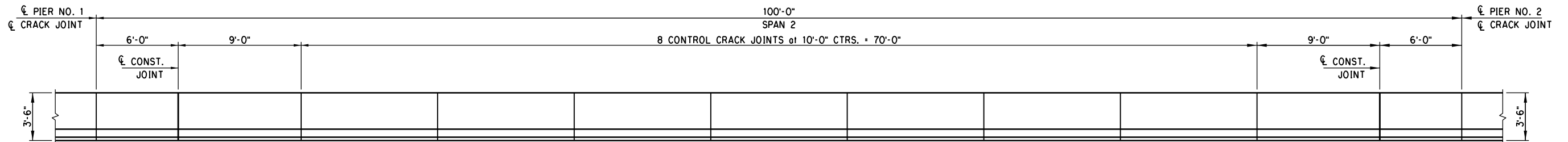

**NORTH PARAPET JOINT SPACING
SPAN NO. 2**

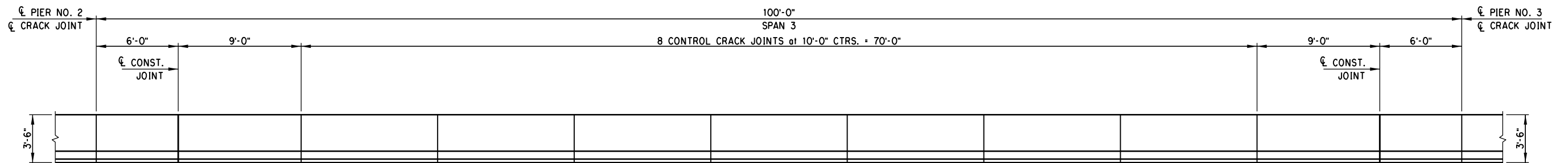

**NORTH PARAPET JOINT SPACING
SPAN NO. 3**

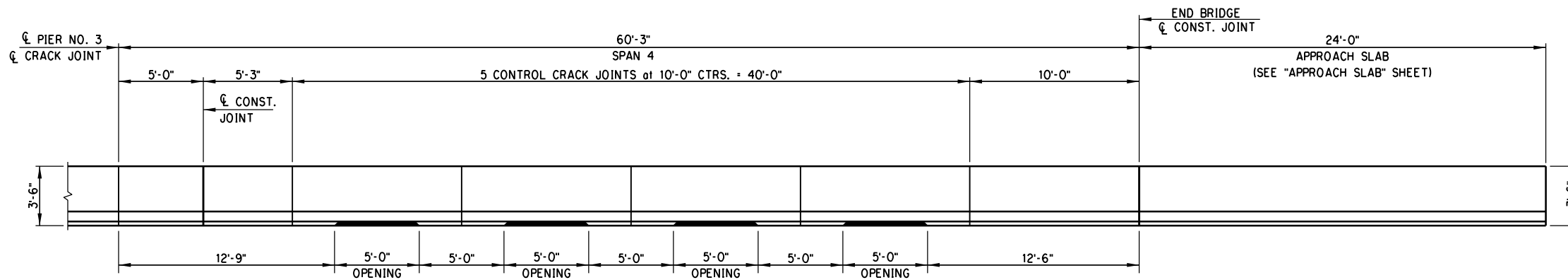

**NORTH PARAPET JOINT SPACING
SPAN NO. 4**

NOTE: FOR ADDITIONAL DETAILS,
SEE STD. FSHP-42-2.

NOTE: NO DRAIN SLOTS ARE TO BE
PLACED IN THE SOUTH PARAPET.

DESIGN	
DRAWN	
CHECKED	
APPROVED	
SQUAD	POE

PHASE 4
BRIDGE "C" OKLAHOMA COUNTY
RAMP "1" OVER I-35

PARAPET LAYOUT

STATE JOB NO. 09032108 SHEET NO. B088

3/1/2024 2:44:04 PM H:\PROJECTS\2789_CrossRoads_Phase 4\Bridges\Drawings\Ph4 Bridges\Bridges\0903208 P4 Bridge C Parapet Layout.dgn

PRESTRESSED CONCRETE BEAM NOTES

COMPRESSIVE STRENGTH:
PROVIDE CONCRETE WITH A COMPRESSIVE STRENGTH OF 7,000 PSI AT TRANSFER OF PRESTRESS AND 10,000 PSI AT 28 DAYS.
STRAND TYPE:
PROVIDE LOW-RELAXATION STRANDS HAVING A NOMINAL DIAMETER OF 0.6" WITH ULTIMATE TENSILE STRENGTH OF 270 KSI.

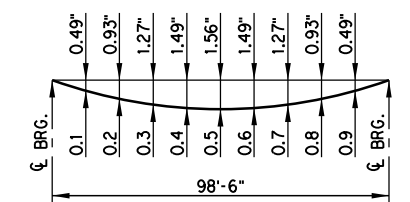

DEAD LOAD DEFLECTION DIAGRAM

NOTE: THE DEAD LOAD DEFLECTION SHOWN ABOVE AT THE TENTH POINTS ARE THE INITIAL DEFLECTIONS DUE TO DECK SLAB + DIAPHRAGMS + HAUNCH + S.I.P. STEEL DECK FORM ALLOWANCE + CONCRETE PARAPET + MEDIAN BARRIER. IT DOES NOT INCLUDE THE BEAM WEIGHT OR FUTURE WEARING SURFACE.

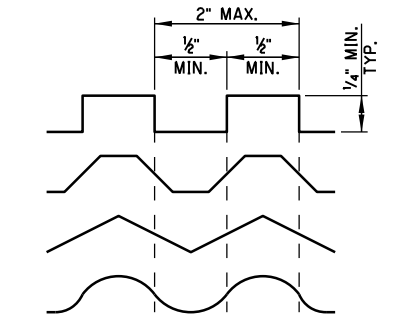

INTENTIONALLY ROUGHENED SURFACE DETAILS

(EXCLUDING END OF BEAM AS NOTED ON ELEVATION) INTENTIONALLY ROUGHEN THE ENTIRE TOP SURFACE OF P.C. BEAM TO A MINIMUM HEIGHT OF 1/4" OVER A MAXIMUM PITCH OF 2" MEASURED LONGITUDINALLY ALONG THE LENGTH OF THE BEAM. PROVIDE A CREST AND TROUGH ASSOCIATED WITH THE HEIGHT OF NOT LESS THAN 1/2". PRODUCE THE ROUGHENED SURFACE BY USING A SPECIAL TROWEL TO FORM ONE OF THE SURFACES SHOWN IN THE DETAILS. BY CLEANING THE CONCRETE SURFACE WITH A STIFF WIRE BRUSH (OR BLASTING) TO EXPOSE THE AGGREGATE TO A HEIGHT OF 1/4". OR BY USING ANOTHER APPROVED METHOD. SUBMIT THE METHOD TO BE USED FOR APPROVAL BY THE ENGINEER. REPAIR ANY DAMAGE TO REINFORCEMENT'S EPOXY COATING BEFORE PLACEMENT OF DECK CONCRETE.

NOTE: FOR EMBEDDED SOLE PLATE DETAILS, SEE SHEET 1 OF 2.

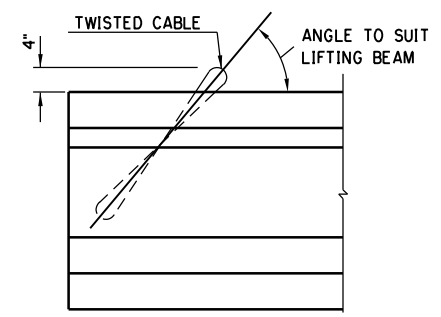

DETAIL OF LIFTING EYE

NOTE: THE USE OF DIAPHRAGM HOLE FOR LIFTING PURPOSES WILL NOT BE PERMITTED.

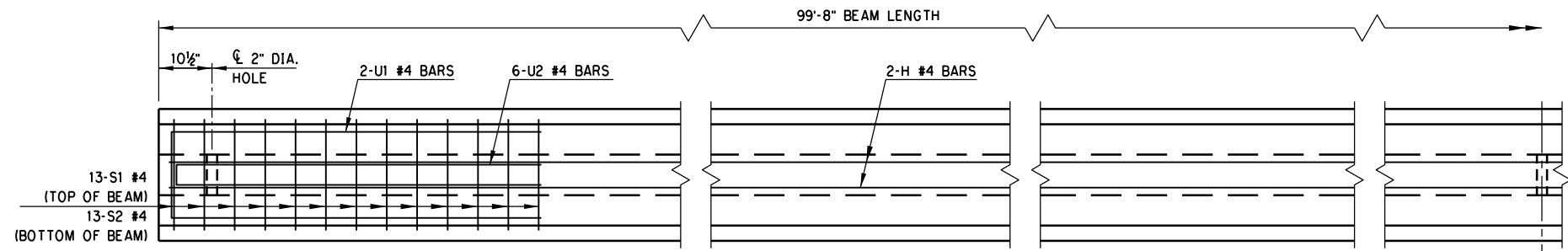

PLAN

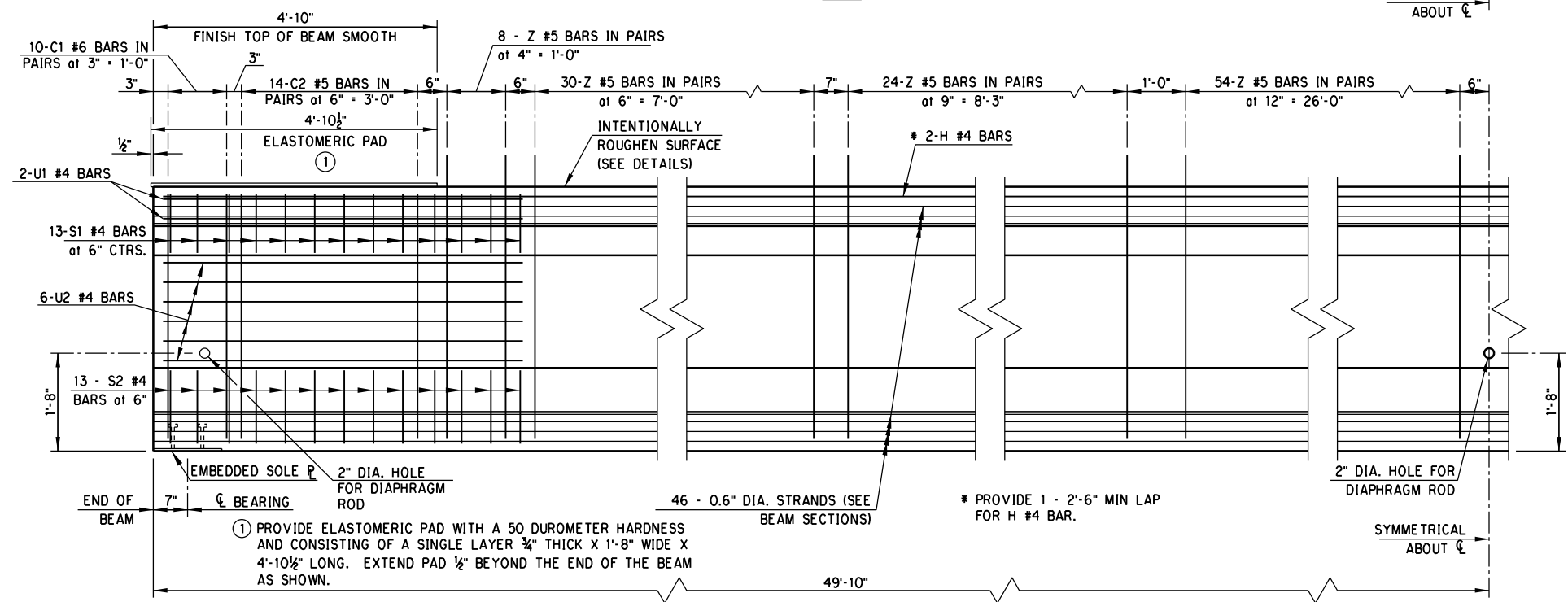

ELEVATION

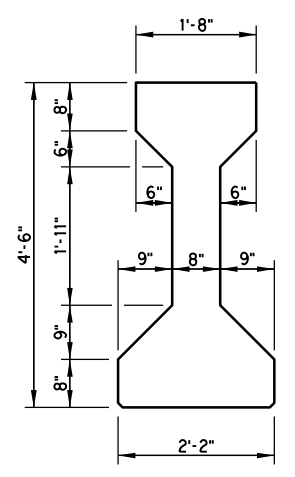

END VIEW
(TYPE IV P.C.B.)

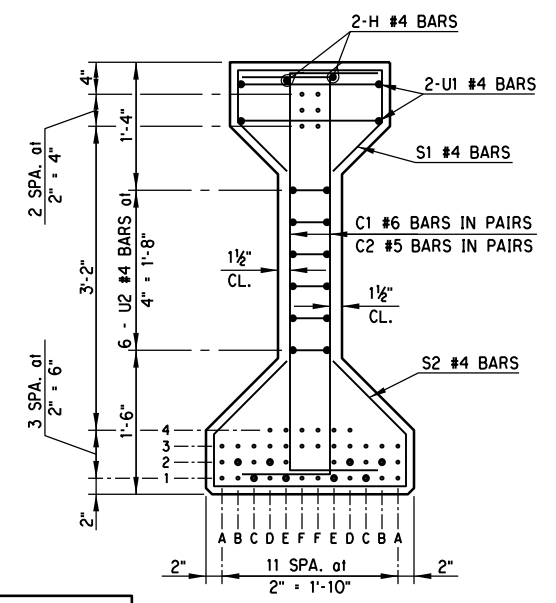

END SECTION

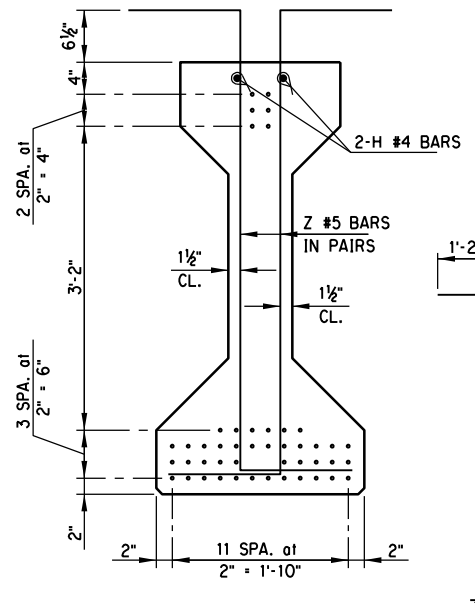

CL SECTION

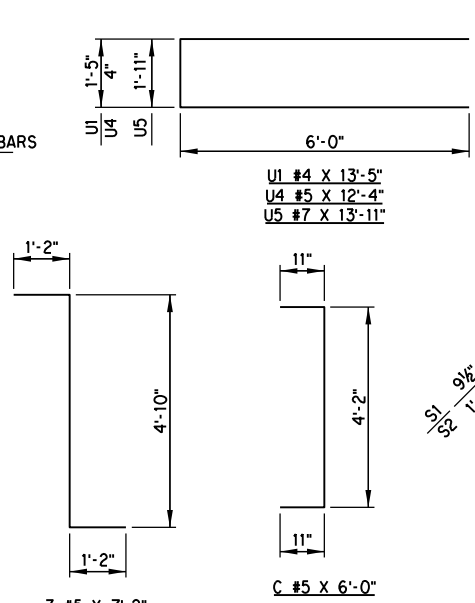

BAR BEND DETAILS

3/1/2024 2:44:05 PM H:\PROJECTS\2789_CrossRoads_Phase 4\Bridges\Drawings\Ph4 Bridges\Bridges\0903208 P4 Bridge C Beam.dgn

DEBOND SCHEDULE	
DEBOND PAIR	DEBOND LENGTH FROM END OF BEAM
C1	16'-0"
E1	8'-0"
B2 & D2	4'-0"

BEAM SECTIONS
(46 - 0.6" DIA. STRANDS)

PHASE 4		OKLAHOMA COUNTY	
BRIDGE "C"		RAMP "1" OVER 1-35	
TYPE IV P.C.B. DETAILS			
SPANS 2 & 3 (SHEET 2 OF 2)			
DESIGN		STATE JOB NO. 09032108	SHEET NO. B089
DRAWN			
CHECKED			
APPROVED			
SQUAD	POE		

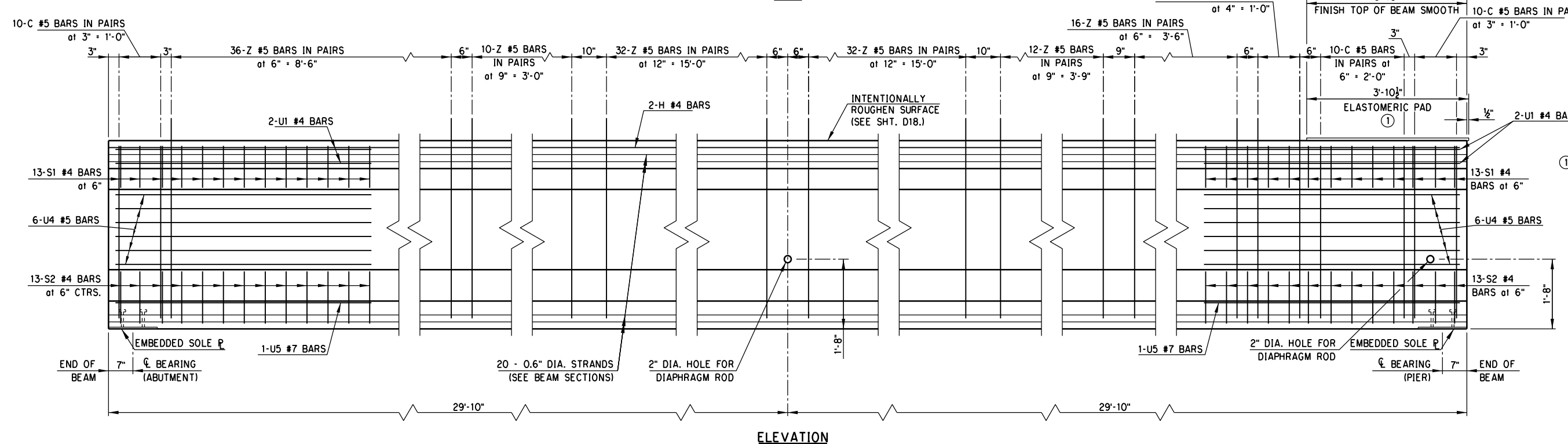
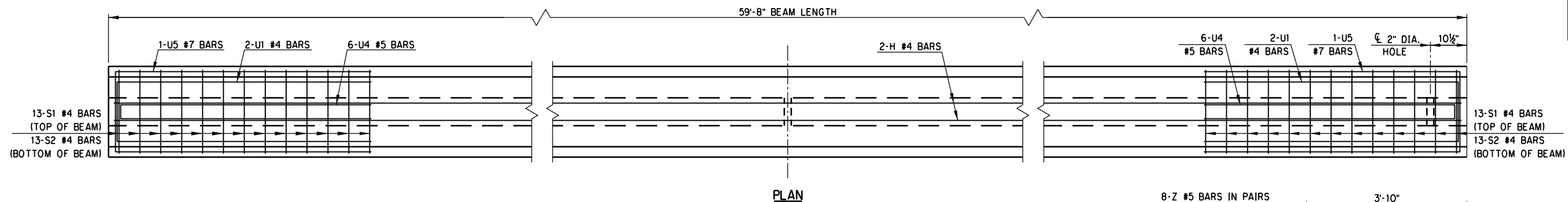

① PROVIDE ELASTOMERIC PAD WITH A 50 DUROMETER HARDNESS AND CONSISTING OF A SINGLE LAYER 3/8" THICK X 1'-8" WIDE X 3'-10 1/2" LONG. EXTEND PAD 1/2" BEYOND THE END OF THE BEAM AS SHOWN.

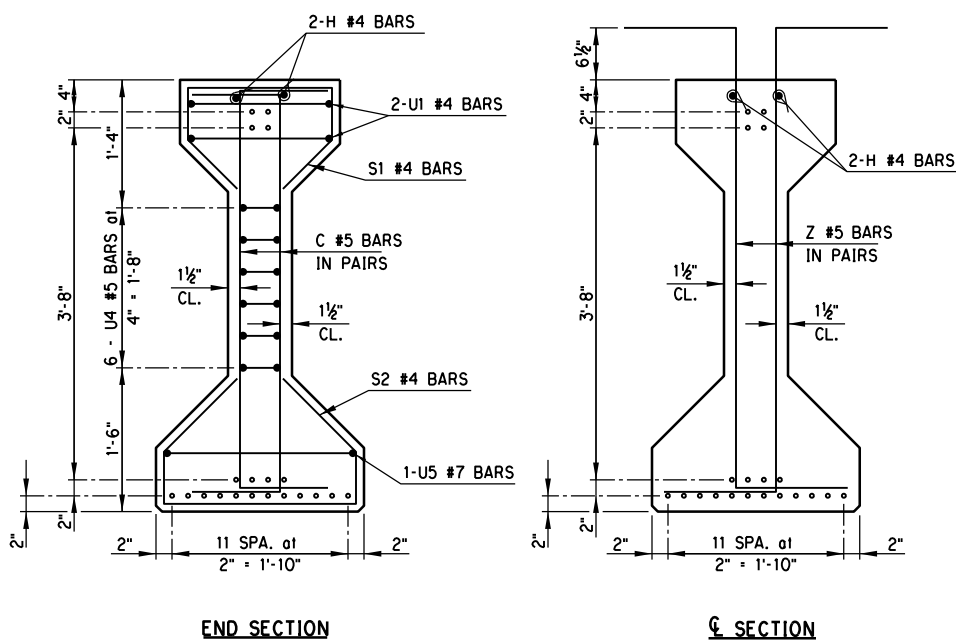

BEAM SECTIONS (20 - 0.6" DIA. STRANDS)

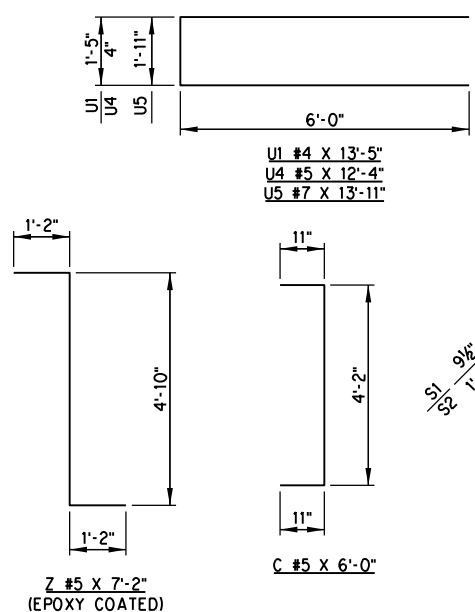

BAR BEND DETAILS

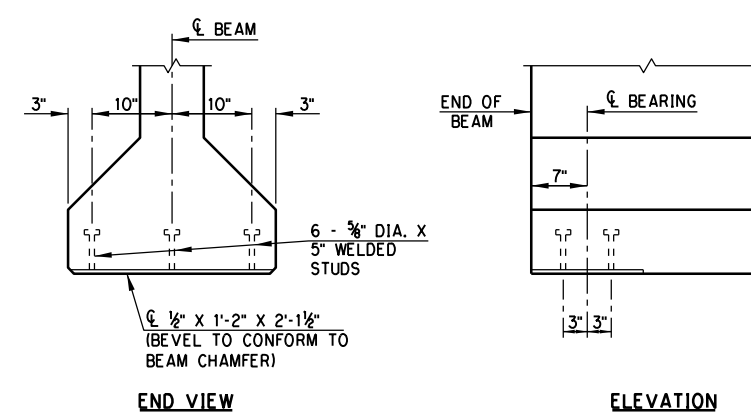

EMBEDDED SOLE PLATE DETAILS

NOTE: PROVIDE AN EMBEDDED SOLE PLATE AT EACH END OF THE BEAM

PRESTRESSED CONCRETE BEAM NOTES

COMPRESSIVE STRENGTH:
PROVIDE CONCRETE WITH A COMPRESSIVE STRENGTH OF 7,000 PSI AT TRANSFER OF PRESTRESS AND 10,000 PSI AT 28 DAYS.
STRAND TYPE:
PROVIDE LOW-RELAXATION STRANDS HAVING A NOMINAL DIAMETER OF 0.6" WITH ULTIMATE TENSILE STRENGTH OF 270 KSI.

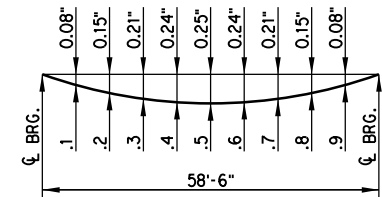

DEAD LOAD DEFLECTION DIAGRAM

NOTE: THE DEAD LOAD DEFLECTION SHOWN ABOVE OF THE TENTH POINTS ARE THE INITIAL DEFLECTIONS DUE TO DECK SLAB + DIAPHRAGMS + HAUNCH + S.I.P. STEEL DECK FORM ALLOWANCE + CONCRETE PARAPET + MEDIAN BARRIER. IT DOES NOT INCLUDE THE BEAM WEIGHT OR FUTURE WEARING SURFACE.

3/1/2024 2:44:05 PM H:\PROJECTS\2789_Crossroads_Phase 4\Bridges\Drawings\Phase 4\Bridges\Bridges\Bridges\Bridges\Bridges\C Beam.dgn

DESIGN		PHASE 4	OKLAHOMA COUNTY
DRAWN		BRIDGE "C"	RAMP "1" OVER 1-35
CHECKED		TYPE IV P.C.B. DETAILS	
APPROVED			
SQUAD	POE	SPANS 1 & 4 (SHEET 1 OF 2)	
		STATE JOB NO. 09032108 SHEET NO. B090	

NOTE: FOR DETAIL OF LIFTING EYE AND INTENTIONALLY ROUGHENED SURFACE DETAILS, SEE SHEET 2 OF 2.

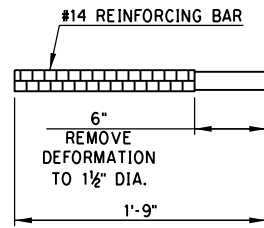

ABUTMENT ANCHOR BAR DETAIL

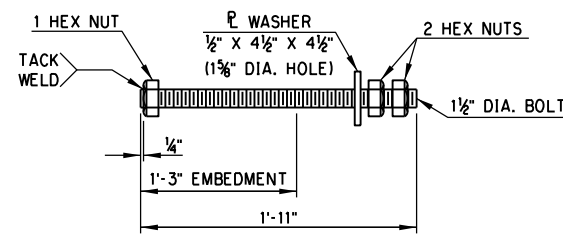

PIER ANCHOR BOLT DETAIL

NOTE: ORIENT THICKEST EDGE OF ANCHOR PLATE TOWARDS ABUTMENT NO. 2.

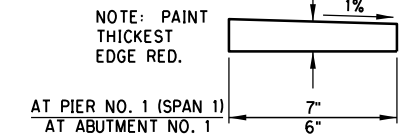

BEVELED ANCHOR PLATE DETAIL

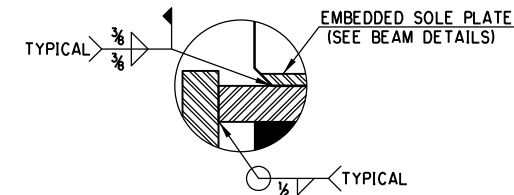

DETAIL "A"

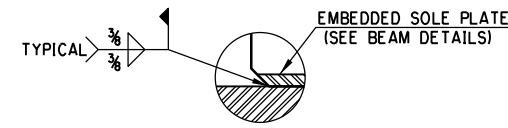

DETAIL "B"

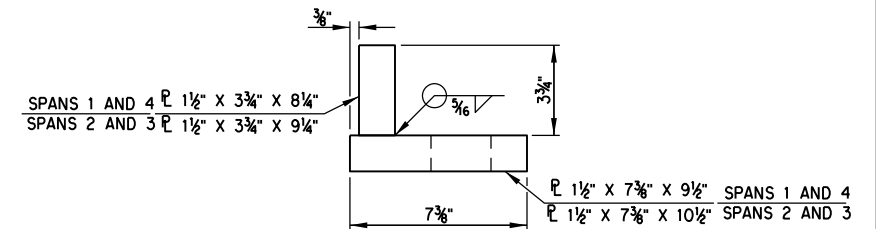

BUILT-UP CONTACT ANGLE DETAIL

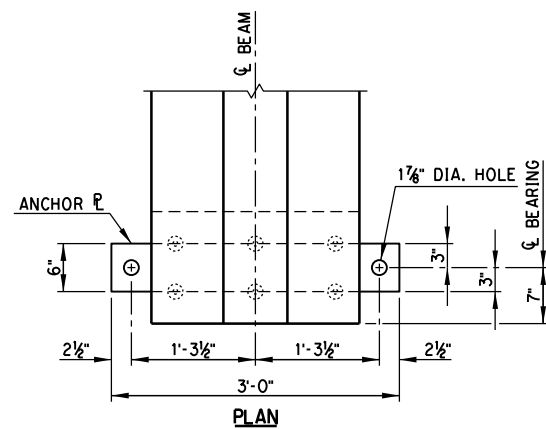

PLAN

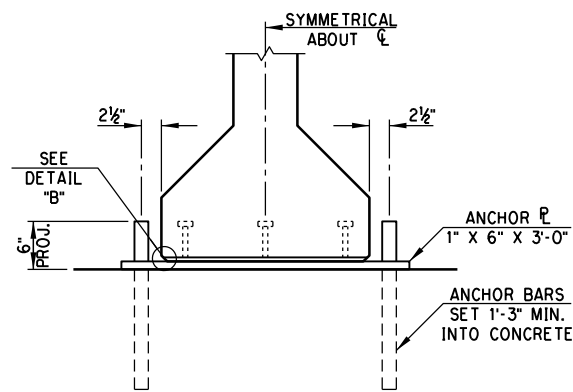

END VIEW

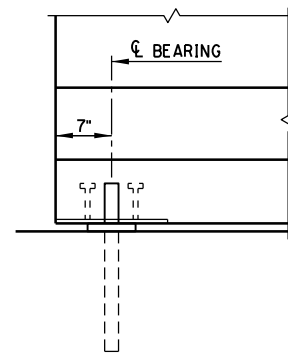

SIDE VIEW

ABUTMENT FIXED BEARING DETAILS

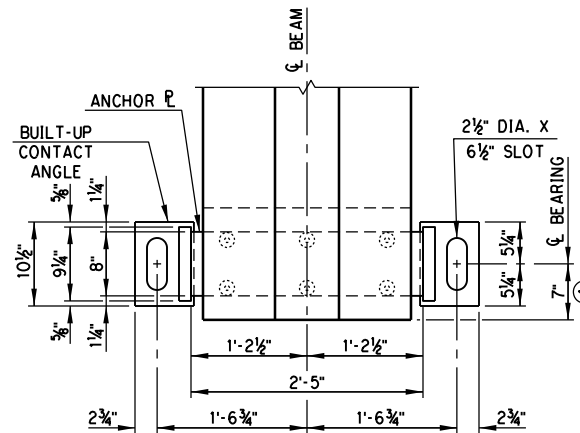

PLAN

(AT BEAMS PLACED IN SPAN 2 & SPAN 3)

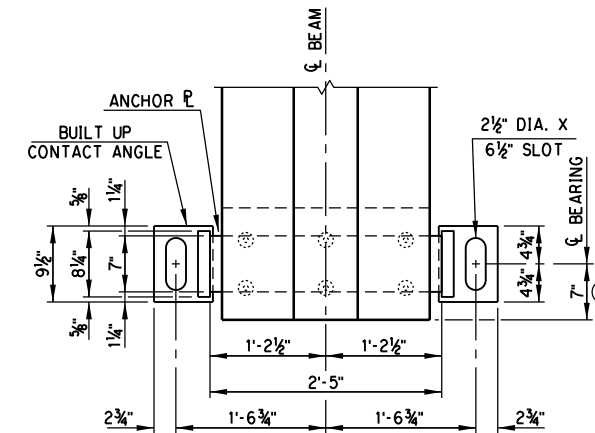

PLAN

(AT BEAMS PLACED IN SPAN 1 & SPAN 4)

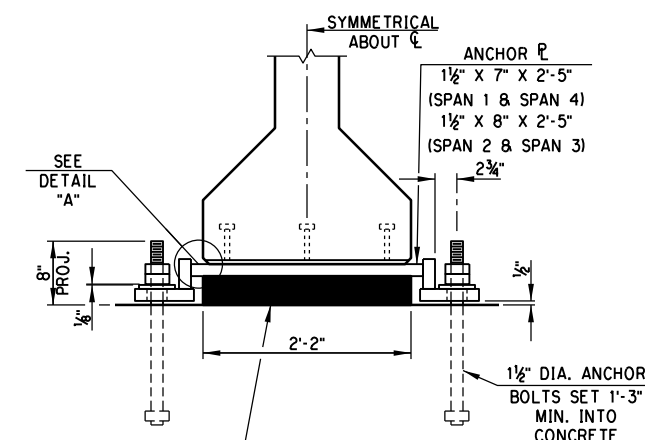

END VIEW

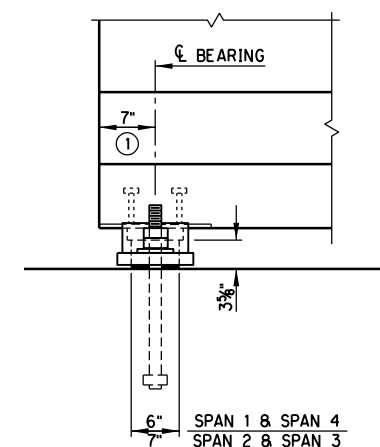

SIDE VIEW

PIER EXPANSION BEARING DETAILS

① CENTER ANCHOR BOLTS IN SLOTS DURING SETTING OF BEAMS. DIMENSION MAY VARY DEPENDING ON TEMPERATURE OF THE TIME OF BEAM SETTING.

ELASTIC BEARING PAD SCHEDULE
(DUROMETER 601)

LOCATION	SIZE (TxLxW)	COVER LAYERS	INTERNAL LAYERS	LAMINATE LAYERS
SPANS 1 & 4	3 5/8" x 6" x 2'-2"	2 at 1/4"	6 at 3/8"	7 at 1/8"
SPANS 2 & 3	3 5/8" x 7" x 2'-2"	2 at 1/4"	6 at 3/8"	7 at 1/8"

EXPANSION BEARING ASSEMBLY NOTES

PROVIDE STRUCTURAL STEEL FOR ANCHOR PLATES, WASHER PLATES, AND BUILT-UP CONTACT ANGLES IN ACCORDANCE WITH ASTM A240 (AUSTENITIC STAINLESS STEEL, TYPE 316, CHARPY V-NOTCH TESTING NOT REQUIRED). FOR ANCHOR BOLTS, PROVIDE CONTINUOUSLY THREADED BARS IN ACCORDANCE WITH ASTM A320, CLASS 2, GRADE B8M (AUSTENITIC STAINLESS STEEL, TYPE 316, CHARPY V-NOTCH TESTING NOT REQUIRED). USE AUSTENITIC STAINLESS STEEL NUTS CONFORMING TO ASTM A194, GRADE 8M. PERFORM ALL WELDING CONSISTENT WITH PROCEDURES FOR STAINLESS STEEL.

FIXED BEARING ASSEMBLY NOTES

PROVIDE STRUCTURAL STEEL FOR ANCHOR PLATES IN ACCORDANCE WITH AASHTO M270 (ASTM A709), GRADE 50W (WEATHERING STEEL, CHARPY V-NOTCH TESTING NOT REQUIRED). FOR ANCHOR BARS, PROVIDE A REINFORCING BAR IN ACCORDANCE WITH AASHTO M31, GRADE 60.

PHASE 4

OKLAHOMA COUNTY

DESIGN	
DRAWN	
CHECKED	
APPROVED	
SQUAD	POE

BRIDGE "C" RAMP "1" OVER 1-35

BEARING ASSEMBLY DETAILS

STATE JOB NO. 09032108 SHEET NO. B091

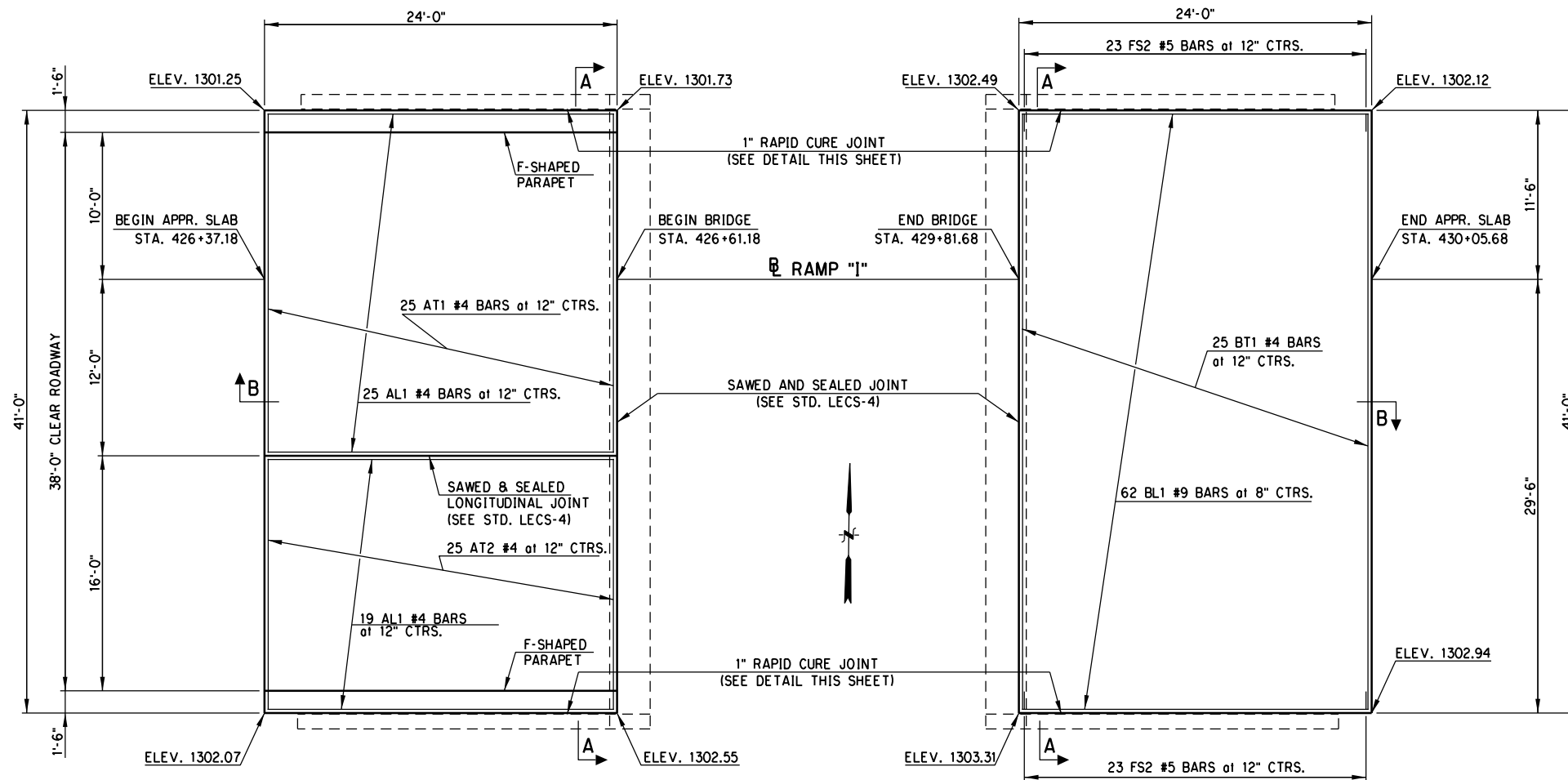

NOTE: DO NOT TIE WITHIN 6" OF THE JOINT BETWEEN THE APPROACH SLAB AND BRIDGE DECK OR WITHIN 6" OF THE SAWS JOINTS OR THE JOINTS BETWEEN THE APPROACH SLAB AND THE WINGWALLS.

NOTE: FOR DETAILS OF PARAPET SEE ODOT STD. FSHP-42-2.

QUANTITIES				
ITEM	UNIT	ABUT. 1	ABUT. 2	TOTAL
APPROACH SLAB	S.Y.	109.40	109.40	218.80
SAW-CUT GROOVING	S.Y.	101.40	101.40	202.80
42" F-SHAPED PARAPET	L.F.	48.00	48.00	96.00
WATER REPELLENT (VISUALLY INSPECTED)	S.F.	24.00	24.00	48.00

APPROACH SLAB NO. 1
TOP REINFORCING MAT DETAILS

APPROACH SLAB NO. 2
BOTTOM REINFORCING MAT DETAILS

NOTE: FOR ADDITIONAL DETAILS AT ABUTMENT DIAPHRAGM SEE "SUPERSTRUCTURE DETAILS" SHEET 2 OF 3.

PLAN

NOTE: PLACE REINFORCING IN THE TOP OF THE APPROACH SLAB 2" FROM EITHER SIDE OF THE SAWS AND SEALED LONGITUDINAL JOINT. FOR ADDITIONAL DETAILS OF LONGITUDINAL JOINT, SEE STANDARD LECS-4.

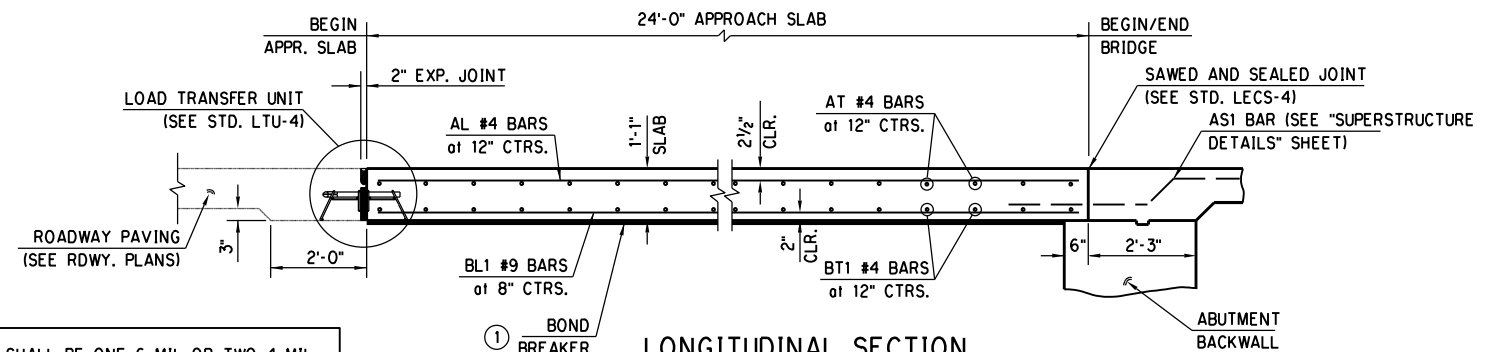

① BOND BREAKER SHALL BE ONE 6 MIL OR TWO 4 MIL POLYETHYLENE SHEETS.

**LONGITUDINAL SECTION
SECTION B - B**

NOTES:

CONCRETE FOR APPROACH SLABS SHALL BE CLASS AA. REINFORCING STEEL SHALL BE GRADE 60.

ALL COST OF MATERIALS, LABOR, AND INCIDENTALS NECESSARY TO COMPLETE THE WORK AS SHOWN SHALL BE INCLUDED IN THE UNIT PRICE BID PER SQUARE YARD OF APPROACH SLAB. THIS PRICE BID SHALL INCLUDE THE COST OF LOAD TRANSFER UNIT, POLYSTYRENE, RAPID CURE JOINT SEALANT, BACKER RODS, SAWING, DOWEL BLOCKS, POLYETHYLENE SHEETING, CLASS AA CONCRETE AND EPOXY COATED REINFORCING STEEL (INCLUDING FS2 PARAPET BARS).

ALL COST OF PARAPET SHALL BE INCLUDED IN PRICE BID PER L.F. OF "42" F-SHAPED PARAPET". THIS PRICE SHALL INCLUDE COST OF ALL FS1, FH1 AND FH2 EPOXY COATED REINFORCING STEEL. PARAPET SHALL BE FULL HEIGHT FOR THE LENGTH OF THE APPROACH SLAB.

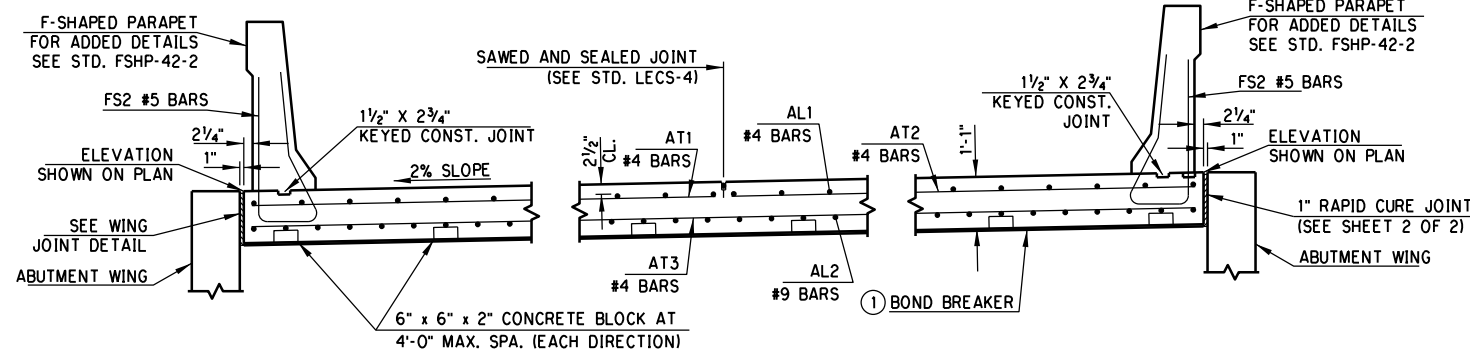

SECTION A-A

DESIGN		PHASE 4	OKLAHOMA COUNTY
DRAWN		BRIDGE "I"	RAMP "I" OVER I-35
CHECKED		APPROACH SLAB DETAILS (SHEET 1 OF 2)	
APPROVED			
SQUAD	POE	STATE JOB NO. 090321081	SHEET NO. B092

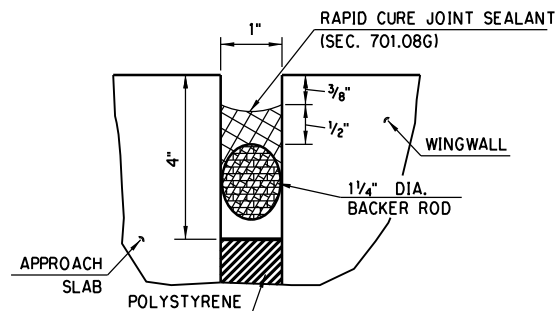

**DETAIL OF RAPID
CURE JOINT
AT WINGWALLS**

NOTE: FOR BACKER ROD AND JOINT SEALER
GENERAL NOTES REFER TO STD. LECS-4.

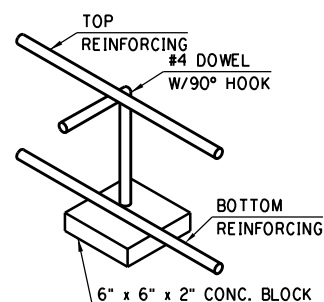

DOWEL BLOCK

NOTE: CONTRACTOR MAY USE APPROVED HIGH
CHAIRS WITH SAND PLATES (HCP) AND 6" x 6" x 2"
PLAIN CONCRETE BLOCKS IN LIEU OF DOWEL
BLOCKS SHOWN. SPACING SHALL BE 4'-0" MAX.
ON CTRS.

BAR LIST - EPOXY COATED
ONE SHOWN 2 REQUIRED
(FOR INFORMATION ONLY)

MARK	NO.	SIZE	FORM	SPACING	LENGTH
AL1	44	#4	STR.	12" C/C	23'-8"
AT1	25	#4	STR.	12" C/C	23'-2"
AT2	25	#4	STR.	12" C/C	17'-2"
BL1	62	#9	STR.	8" C/C	23'-8"
BT1	31	#4	STR.	12" C/C	40'-8"
FS2	25	#5	BNT.	12 C/C	7'-4"

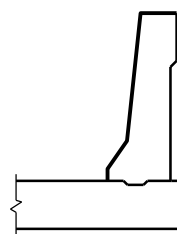

**WATER REPELLENT
SURFACE TREATMENT**

SURFACES INDICATED WITH HEAVY LINES
SHALL BE TREATED WITH A PENETRATING
WATER REPELLENT SURFACE TREATMENT.

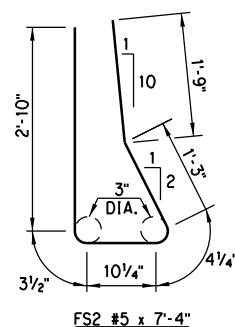

NOTE: FS2 BARS SHALL BE TIED IN PLACE BEFORE
POURING THE CONCRETE FOR THE APPROACH SLAB.

NOTE: ALL BENT BAR DIMENSIONS
ARE OUT TO OUT.

3/1/2024 2:44:08 PM H:\PROJECTS\2789_CrossRoads_Phase 4\Bridges\Drawings\Ph4 Bridges\Bridges\0903208 P4 Bridge C Approach.dgn

DESIGN		PHASE 4	OKLAHOMA COUNTY
DRAWN		BRIDGE "C"	RAMP "I" OVER I-35
CHECKED		APPROACH SLAB DETAILS (SHEET 2 OF 2)	
APPROVED			
SQUAD	POE	STATE JOB NO. 090321081	SHEET NO. B093

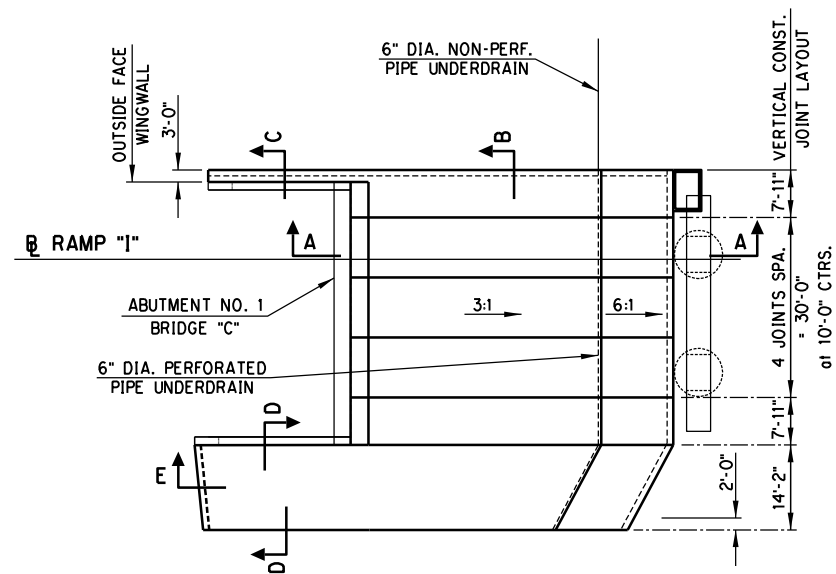

SLOPE WALL PLAN
AT ABUTMENT NO. 1

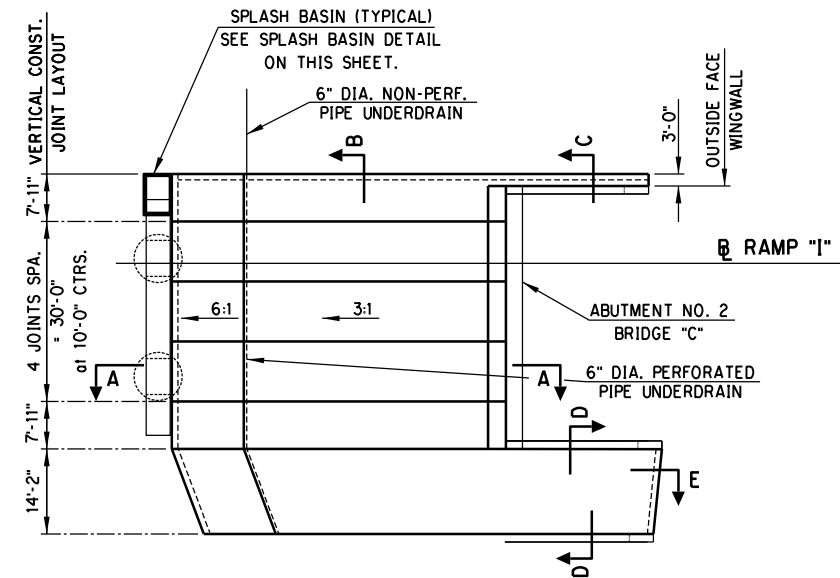

SLOPE WALL PLAN
AT ABUTMENT NO. 2

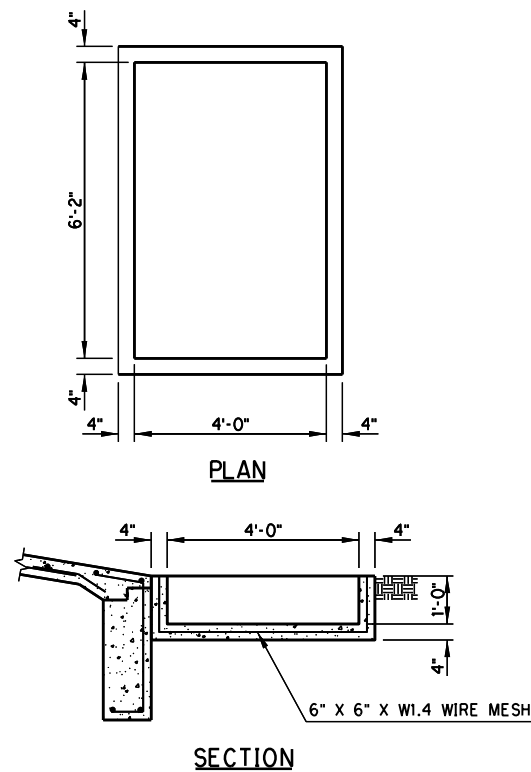

SPLASH BASIN DETAIL

FOR SECTION A-A, B, C, D, & E, SEE SHEET 2 OF 2.

QUANTITIES				
ITEM	UNIT	ABUT. 1	ABUT. 2	TOTAL
CLASS C CONCRETE	C.Y.	1.00	1.00	2.00
SLOPE WALL (5")	S.Y.	420.00	435.00	853.00
6" PERFORATED PIPE UNDERDRAIN ROUND	L.F.	61.00	61.00	122.00
① 6" NON-PERF. PIPE UNDERDRAIN RND.	L.F.	20.00	20.00	40.00

- ① NON-PERFORATED PIPE SHALL BE CONNECTED TO PERFORATED PIPE AND EXTENDED OUTSIDE THE GROUND LINE TO DRAIN, AS DIRECTED IN THE FIELD BY THE ENGINEER. ENGINEER MAY ADJUST ALIGNMENT IN THE FIELD. PROVIDE 1% MIN. SLOPE TO DRAIN.

3/1/2024 2:44:09 PM H:\PROJECTS\2789_CrossRoads_Phase 4\Bridges\Drawings\Ph4 Bridges\Bridges\0903208 P4 Bridge C SlopeWall.dgn

DESIGN		PHASE 4	OKLAHOMA COUNTY
DRAWN		BRIDGE "C"	RAMP "I" OVER 1-35
CHECKED		SLOPEWALL DETAILS (SHEET 1 OF 2)	
APPROVED			
SQUAD	POE		
		STATE JOB NO. 09032108	SHEET NO. B094

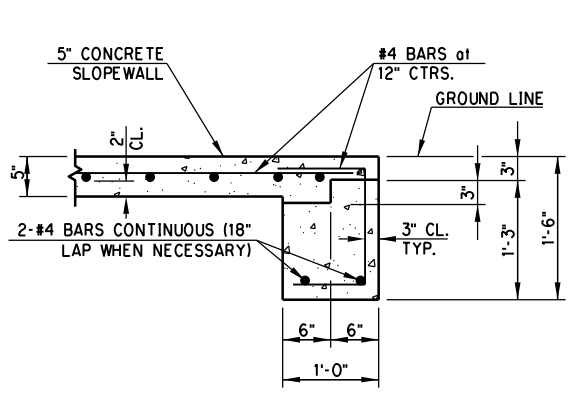

SECTION B

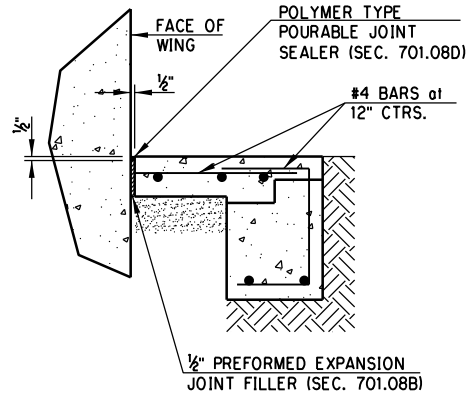

SECTION C

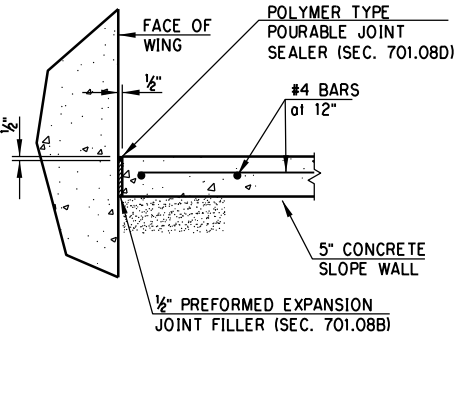

SECTION D

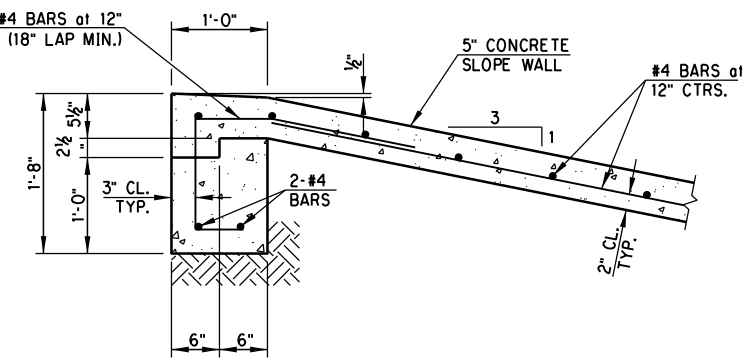

SECTION E

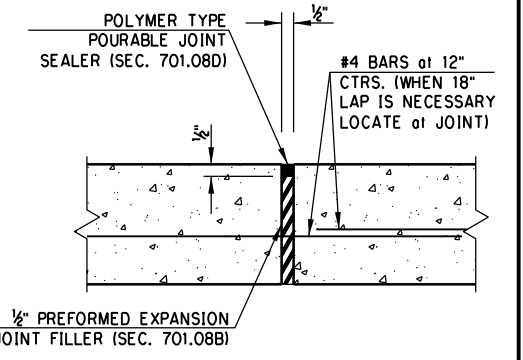

DETAIL OF VERTICAL CONSTRUCTION JOINT

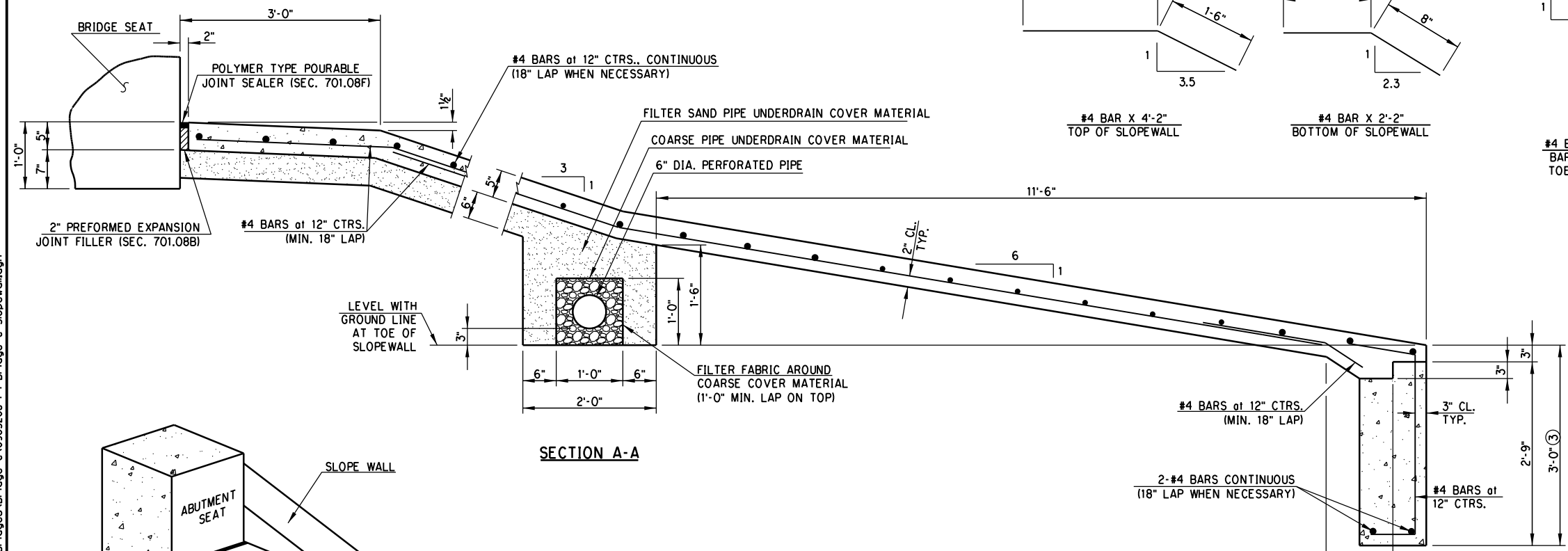

SECTION A-A

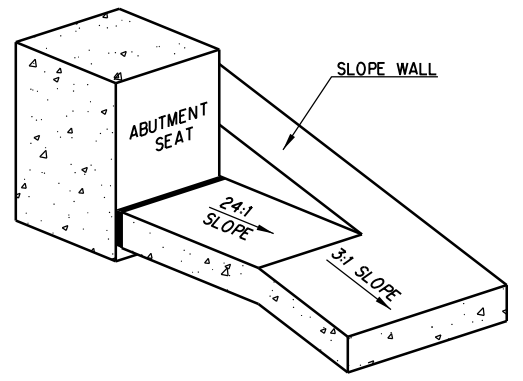
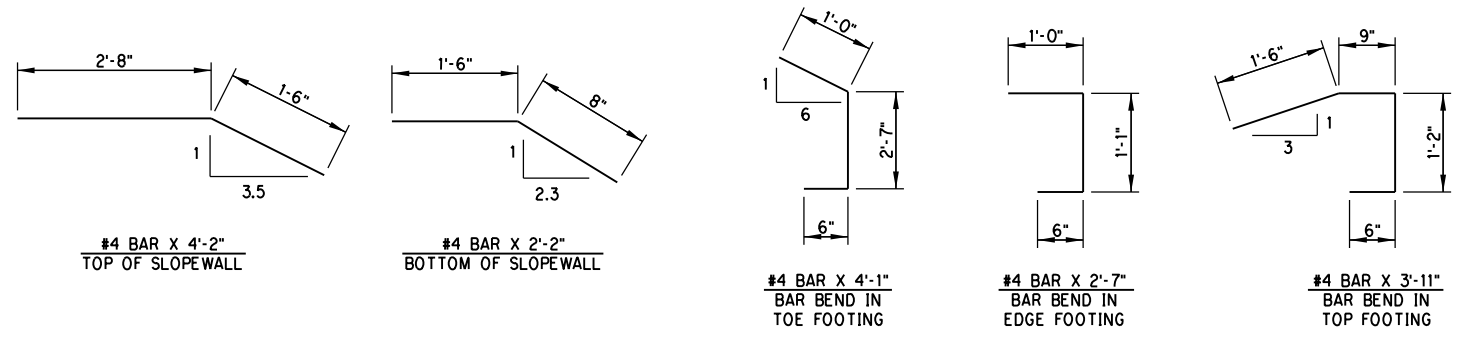

ISOMETRIC VIEW AT END OF ABUTMENTS

SLOPEWALL NOTES

1. ALL CONCRETE IN THE SLOPE WALL SHALL BE CLASS A CONCRETE AND SHALL BE POURED IN THE DRY. ALL CONSTRUCTION SHALL BE IN ACCORDANCE WITH SECTIONS 509 AND 610 OF THE STANDARD SPECIFICATIONS.
2. NO HORIZONTAL CONSTRUCTION JOINTS WILL BE PERMITTED IN THE SLOPE WALL. FINAL NUMBER AND LOCATION OF VERTICAL CONSTRUCTION JOINTS WILL BE DETERMINED IN THE FIELD BY THE ENGINEER.
3. SURFACE AREA OF TOE AND EDGES OF SLOPE WALL INCLUDED IN PAY QUANTITY SHOWN.
4. ALL COSTS OF THE JOINT SEALER AND FILLER, REINFORCING STEEL, CONCRETE, EXCAVATION, FILTER SAND COARSE UNDERDRAIN COVER MATERIAL, LABOR, FORMS AND INCIDENTALS NECESSARY TO COMPLETE THE WORK AS SHOWN, SHALL BE INCLUDED IN THE CONTRACT PRICE BID FOR SLOPE WALL (5').
5. SPLASH BASINS WILL BE MEASURED BY THE CUBIC YARDS OF CLASS "C" CONCRETE REQUIRED TO CONSTRUCT BASINS AS SHOWN IN THE PLANS.

DESIGN		PHASE 4	OKLAHOMA COUNTY
DRAWN		BRIDGE "C"	RAMP "1" OVER 1-35
CHECKED		SLOPEWALL DETAILS (SHEET 2 OF 2)	
APPROVED			
SQUAD	POE	STATE JOB NO. 09032106	SHEET NO. B095

3/1/2024 2:44:10 PM H:\PROJECTS\2789_CrossRoads_Phase 4\Bridges\Drawings\Ph4 Bridges\Bridges\0903208 P4 Bridge C SlopeWall.dgn

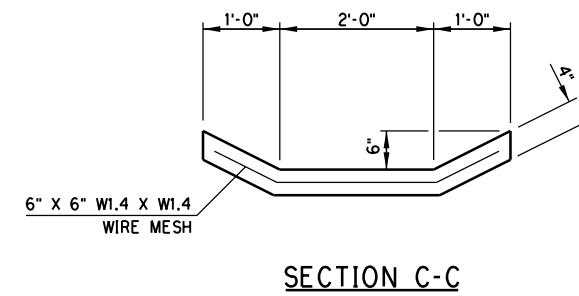
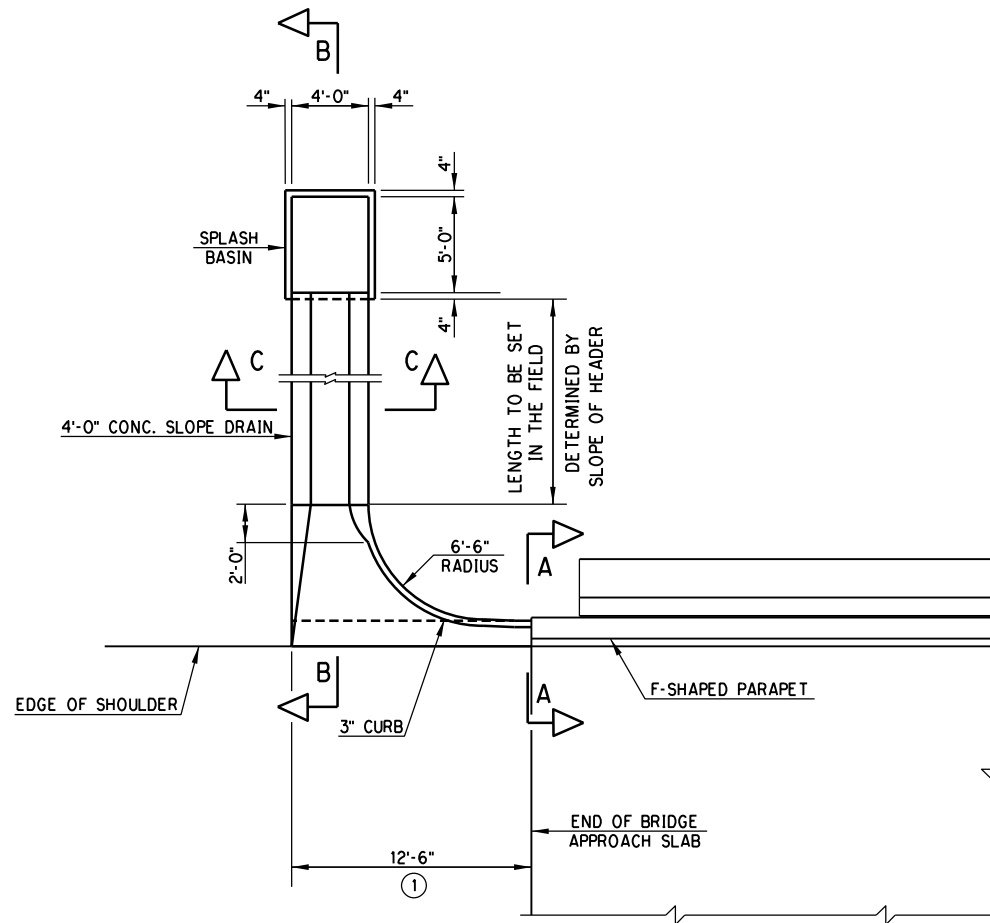
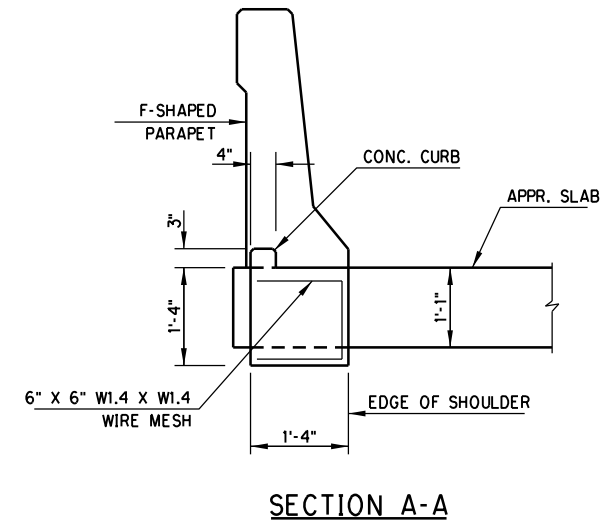
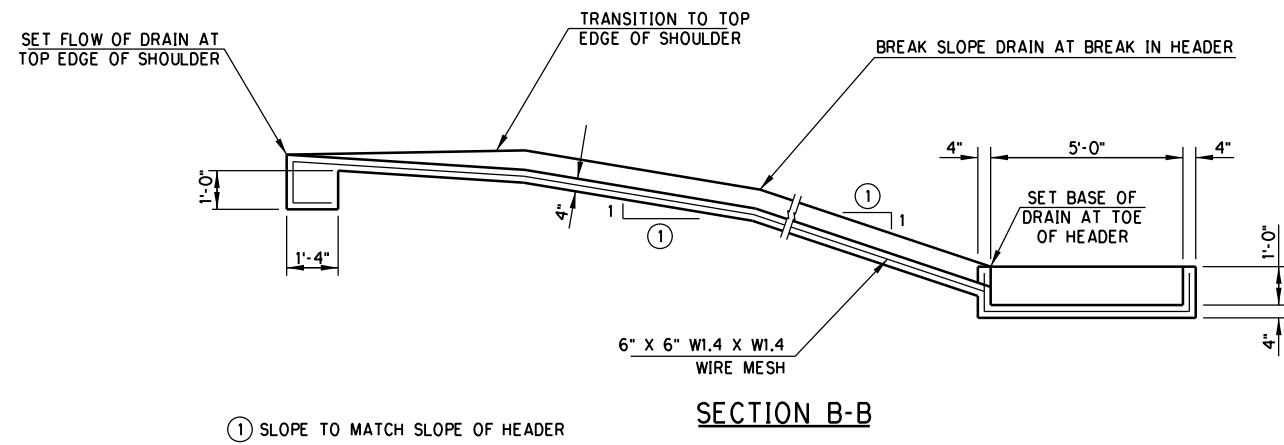

NOTE:
SLOPE DRAIN AND CURBS SHALL BE CONSTRUCTED USING CLASS "C" CONCRETE
AS SHOWN ON THIS SHEET. ALL COSTS OF EXCAVATION, SLOPE DRAINS, CURBS, AND
REINFORCING STEEL SHALL BE INCLUDED IN THE PAY ITEM FOR "CLASS "C" CONCRETE".

3/1/2024 2:44:11 PM
H:\PROJECTS\2789_CrossRoads_Phase 4\Bridges\Drawings\Ph4 Bridges\Bridges C\0903208 P4 Bridge C DEB.dgn



DESIGN		PHASE 4	OKLAHOMA COUNTY
DRAWN		BRIDGE "C"	RAMP "1" OVER 1-35
CHECKED		<p>DRAINS AT END OF BRIDGE DETAILS (SHEET 1 OF 2)</p> <p>STATE JOB NO. 09032108 SHEET NO. B096</p>	
APPROVED			
SQUAD	POE		

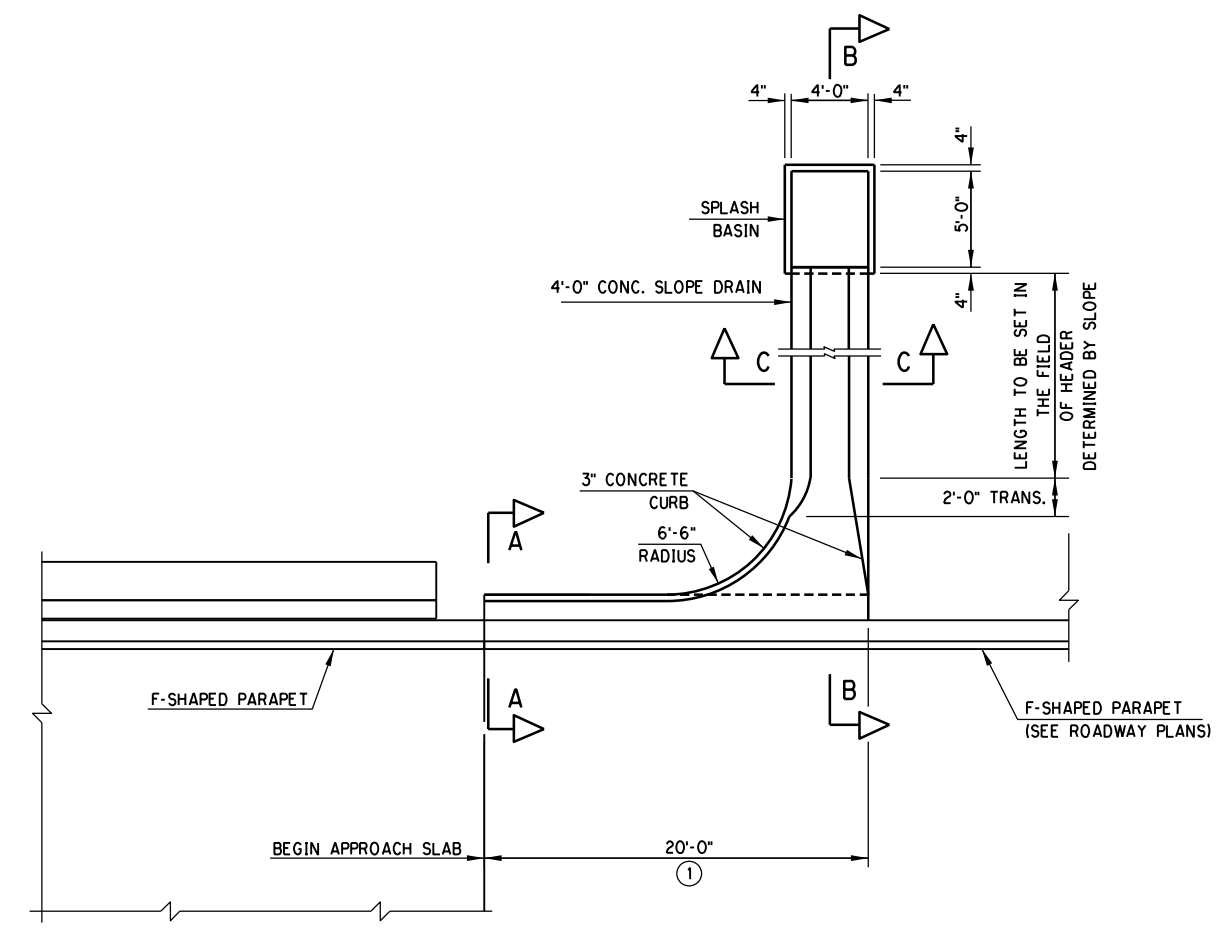
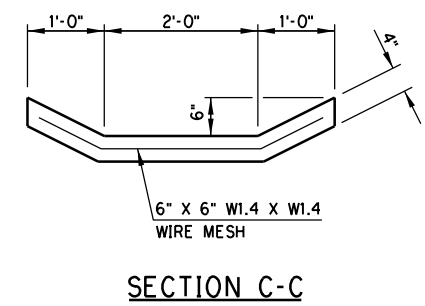
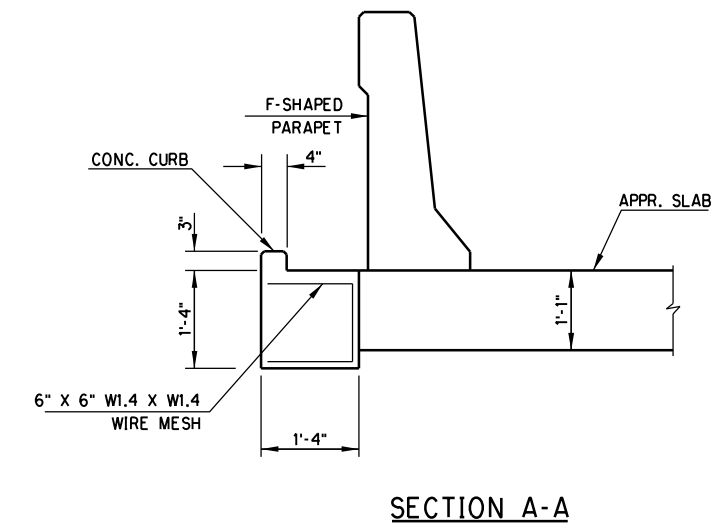
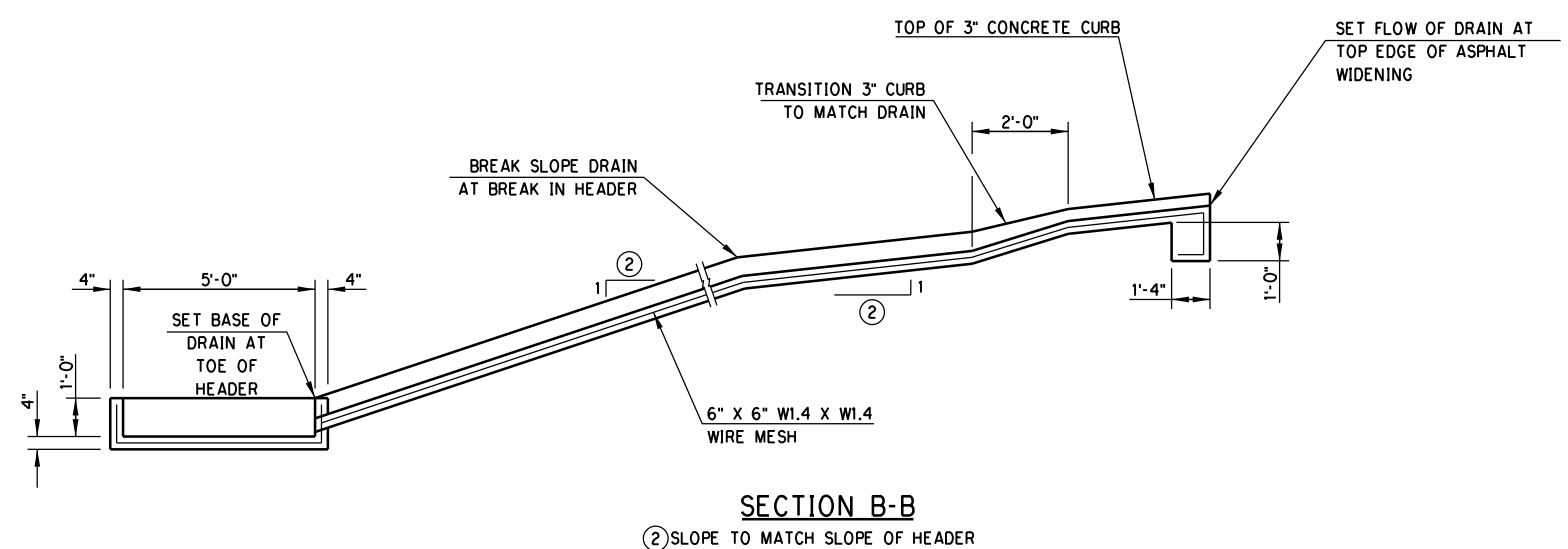

SLOPE DRAIN PLAN
ABUT. NO. 2

① ACTUAL LOCATION OF DRAIN TO BE SET IN THE FIELD.

NOTE:
SLOPE DRAIN AND CURBS SHALL BE CONSTRUCTED USING CLASS "C" CONCRETE AS SHOWN ON THIS SHEET. ALL COSTS OF EXCAVATION, SLOPE DRAINS, CURBS, AND REINFORCING STEEL SHALL BE INCLUDED IN THE PAY ITEM FOR "CLASS "C" CONCRETE".

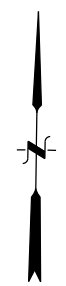

PHASE 4		OKLAHOMA COUNTY	
BRIDGE "C"		RAMP "1" OVER 1-35	
DESIGN		<p align="center">DRAINS AT END OF BRIDGE DETAILS (SHEET 2 OF 2)</p> <p>STATE JOB NO. 09032108 SHEET NO. B097</p>	
DRAWN			
CHECKED			
APPROVED			
SQUAD	POE		

3/1/2024 2:44:11 PM H:\PROJECTS\2789_CrossRoads_Phase 4\Bridges\Drawings\Ph4 Bridges\Bridges C\0903208 P4 Bridge C DEB.dgn

**90% PLAN
SUBMITTAL**
2/29/2024

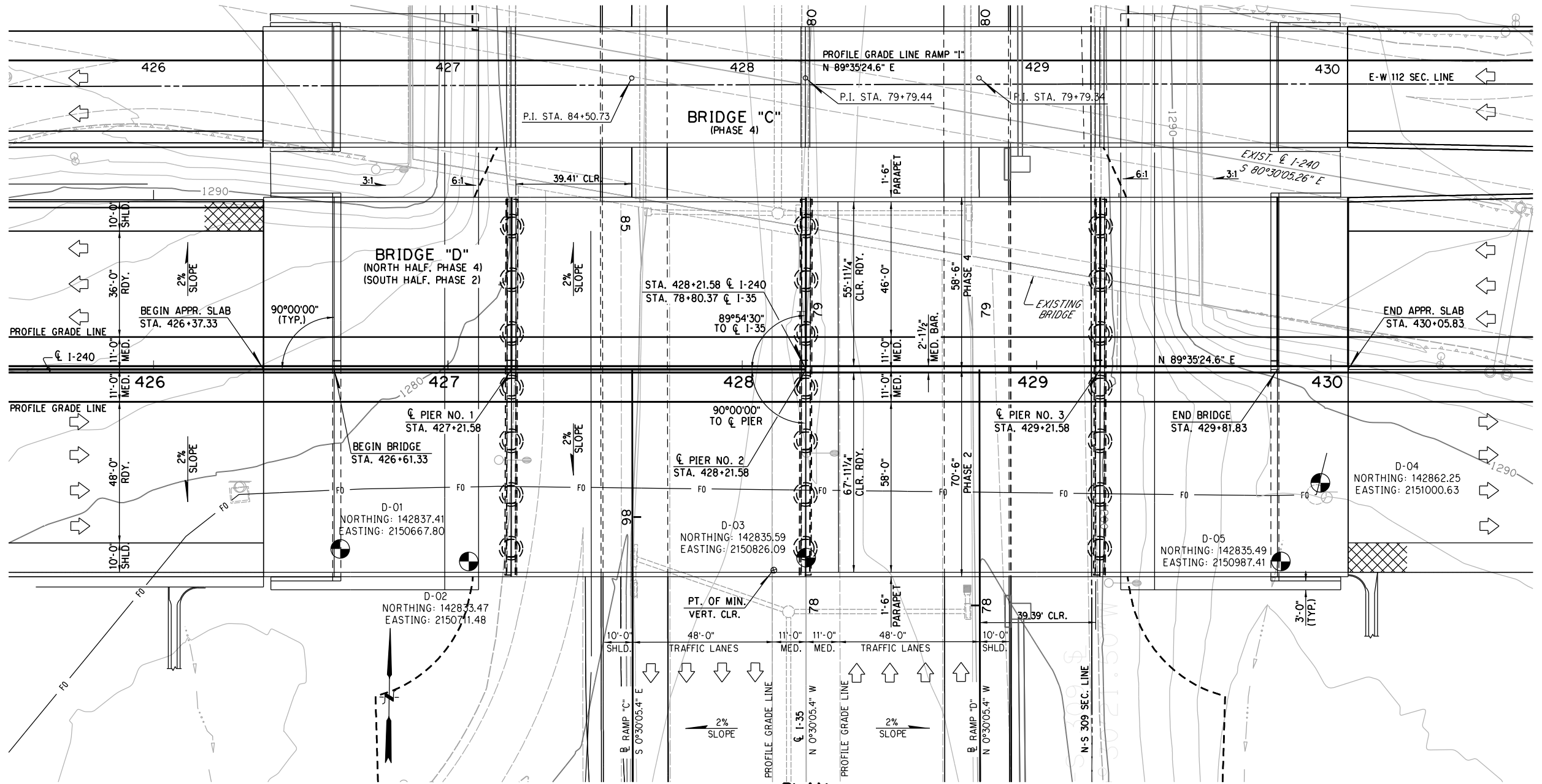

BM 25 - *6 REBAR
EAST OF CREEK BEND
STA. 421+26.09 @ I-240
620.62' RT ELEV. 1287.24

BM 26 - *6 x 30' LONG REBAR
STA. 423+82.37 @ I-240
774.34' RT ELEV. 1283.54

BM 54 - *X" ON TOP OF CURB
PARKING LOT TEXAS ROADHOUSE
STA. 439+22.55 @ I-240
209.30' RT ELEV. 1300.07

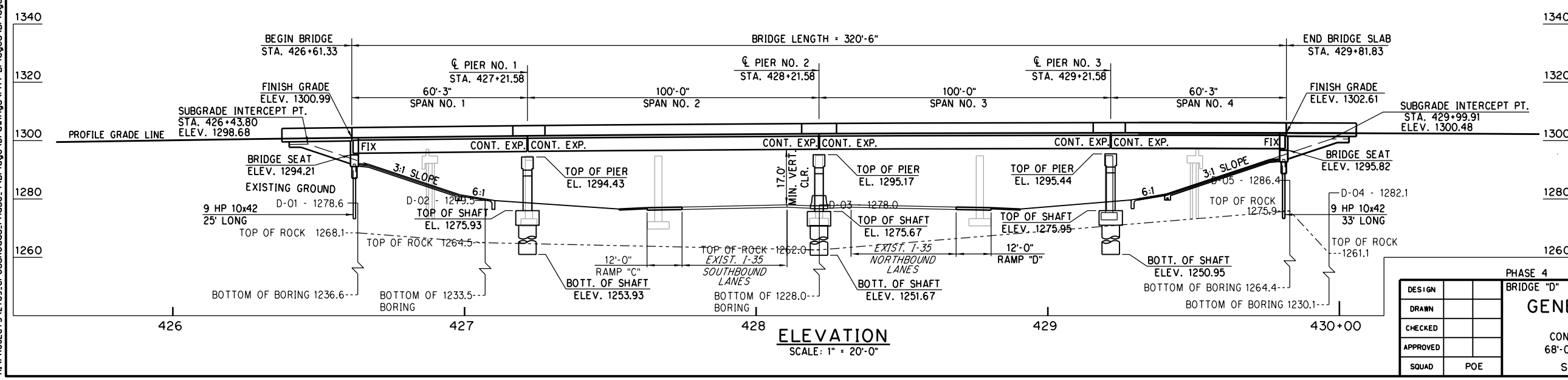
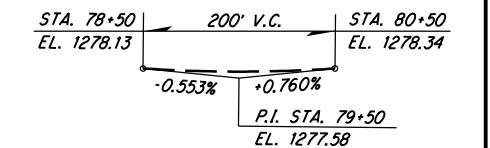
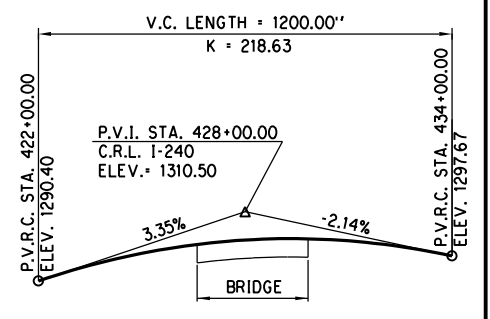

DESIGN	
DRAWN	
CHECKED	
APPROVED	
SQUAD	POE

PHASE 4
OKLAHOMA COUNTY
BRIDGE "D"
I-240 OVER I-35
GENERAL PLAN & ELEVATION
@ STA. 428+21.58 @ I-240
CONST. 60'-100'-100'-60' TYPE IV P.C. BEAM SPANS -
68'-0" AND 56'-0" CLR. RDY. W/42" F-SHAPED PARAPET
STATE JOB NO. 09032(108) SHEET NO. B098

3/1/2024 2:25:20 PM
 H:\PROJECTS\2789_Crossroads_Phase 4\Bridges\Drawings\Phase 4\Bridges\Bridges\Bridges\Bridges D GPE.dgn

BRIDGE CONSTRUCTION SEQUENCE

PHASE 2

1. CONSTRUCT PORTION OF NEW BRIDGE, SOUTH OF $\text{CL } 1-240$.

PHASE 4

1. INSTALL TEMPORARY BARRIERS ON PORTION OF NEW BRIDGE, SOUTH OF $\text{CL } 1-240$.
2. DIVERT WESTBOUND AND EASTBOUND TRAFFIC ONTO PORTION OF NEW BRIDGE, SOUTH OF $\text{CL } 1-240$.
3. REMOVE EXISTING BRIDGE AND CONSTRUCT REMAINING PORTION OF NEW BRIDGE, NORTH OF $\text{CL } 1-240$.
4. DIVERT WESTBOUND TRAFFIC ONTO THE NORTH SIDE OF $\text{CL } 1-240$ OF THE NEW BRIDGE AND REMOVE TEMPORARY BARRIERS.

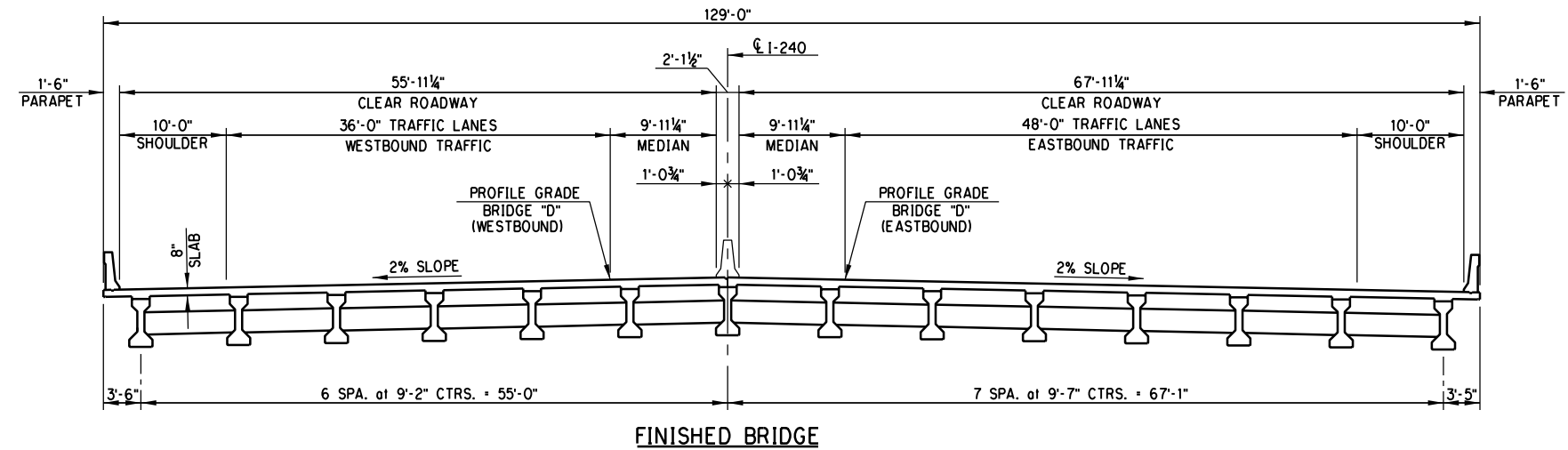
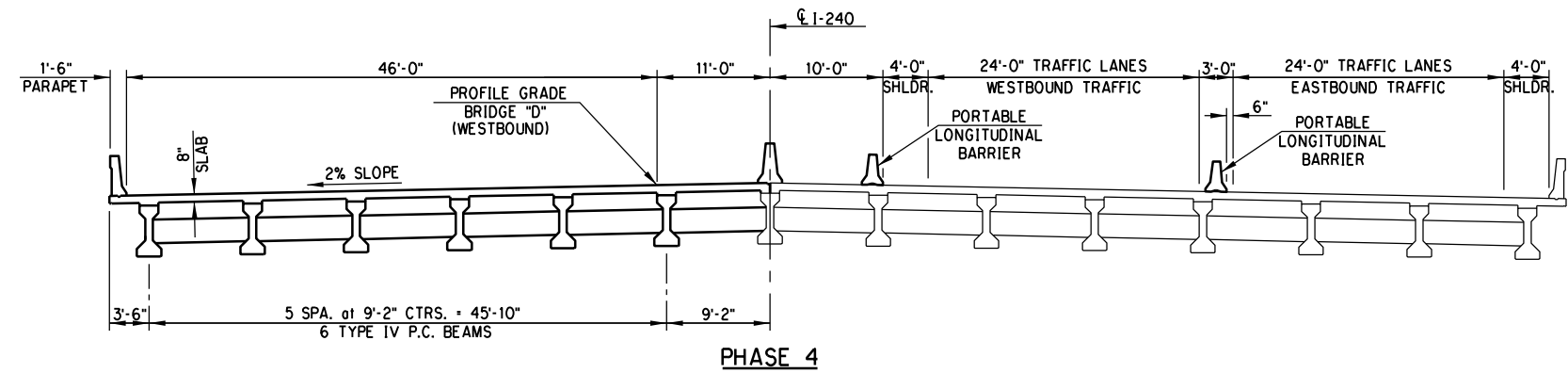
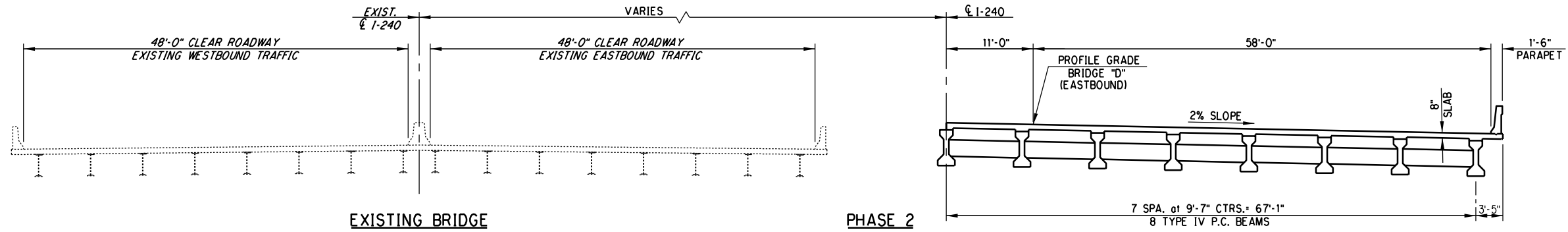

3/1/2024 2:25:25 PM H:\PROJECTS\2789_CrossRoads_Phase 4 Bridge\Drawings\Ph4 Bridges\Bridge D Construction Sequence.dgn

DESIGN		PHASE 4	OKLAHOMA COUNTY
DRAWN		BRIDGE "D"	1-240 OVER 1-35
CHECKED		BRIDGE CONSTRUCTION SEQUENCE	
APPROVED			
SQUAD	POE		
		STo+E JOB NO. 09032(08)	SHEET NO. B100

90% PLAN
SUBMITTAL
2/29/2024

BORING NUMBER D-01
NORTHING: 142837.41
EASTING: 2150667.80
DATE DRILLED: 5/16/17

BORING NUMBER D-02
NORTHING: 142833.47
EASTING: 2150711.48
DATE DRILLED: 5/16/17

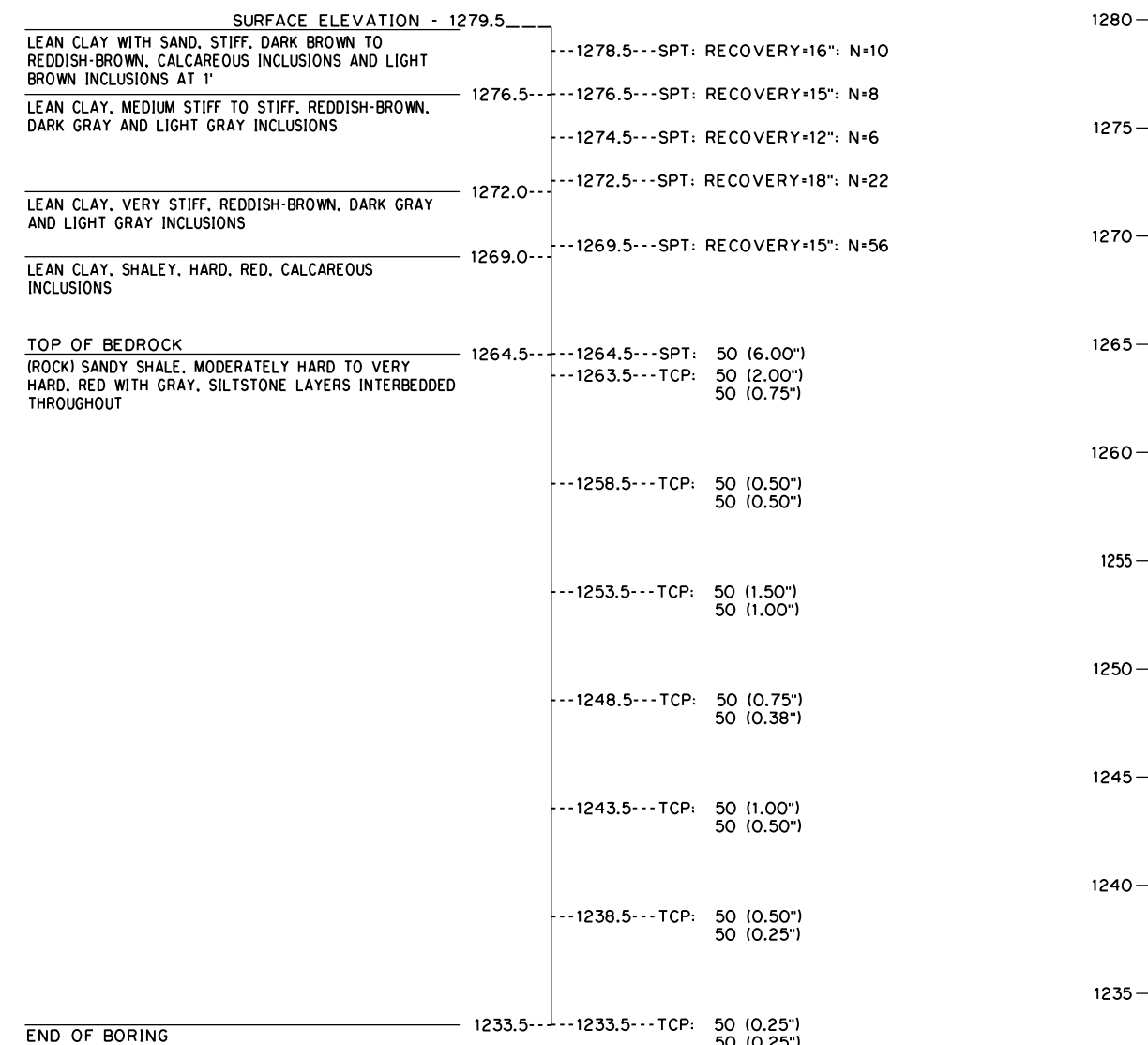
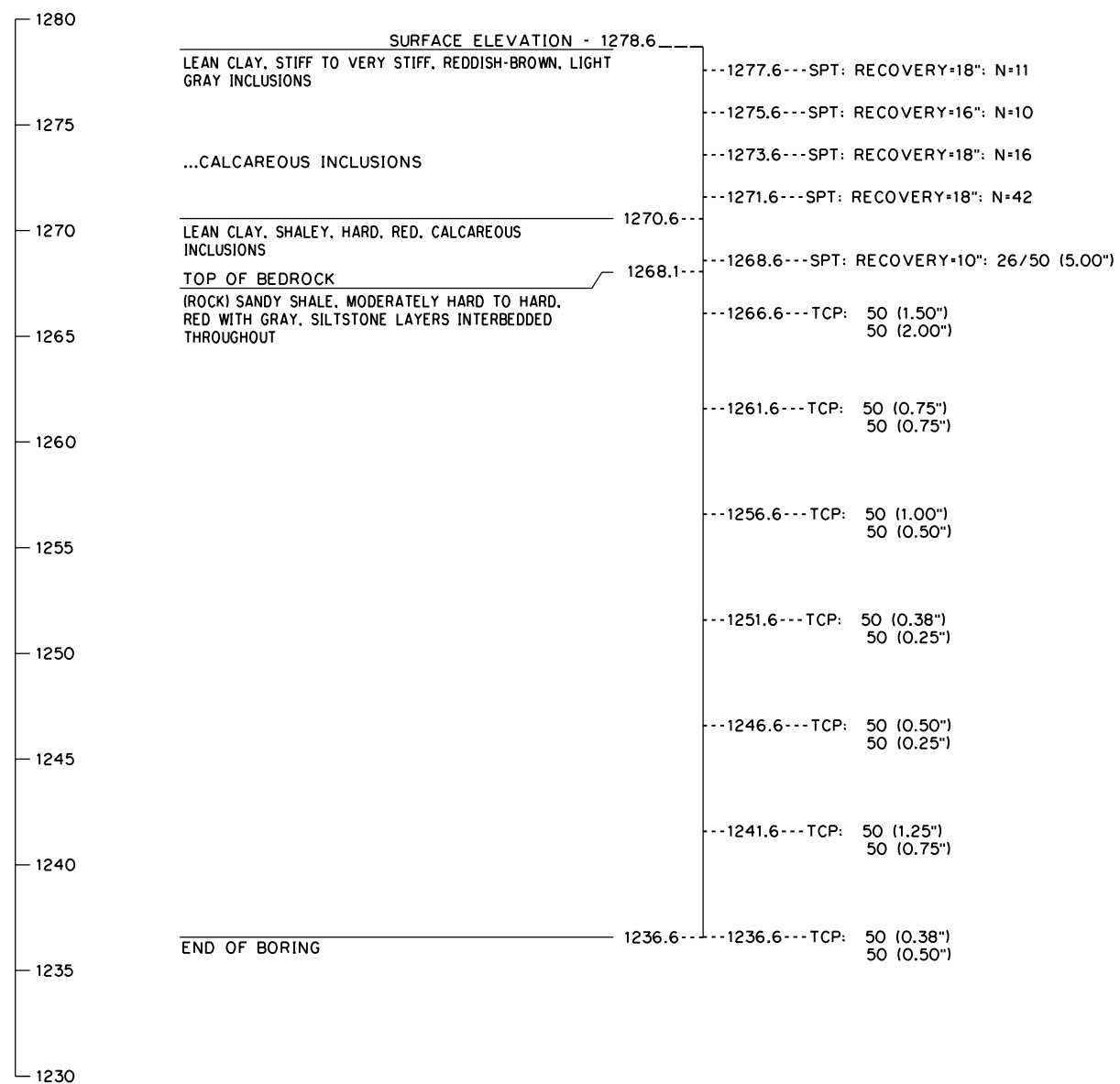

GEOTECHNICAL REPORT

ALL GEOTECHNICAL INFORMATION CONTAINED ON THIS SHEET IS COVERED BY THE ENGINEERING SEAL AFFIXED TO AN ORIGINAL GEOTECHNICAL ENGINEERING REPORT THAT HAS BEEN STAMPED AND SEALED BY A PROFESSIONAL ENGINEER LICENSED IN OKLAHOMA. TO OBTAIN A COPY OF THE COMPLETE REPORT, CONTACT THE ODOT OFFICE ENGINEER AT (405) 521-2625. THE CONTRACTOR SHOULD BE FULLY AWARE OF THE SITE CONDITIONS PRIOR TO BEGINNING WORK. ANY ADDITIONAL GEOTECHNICAL INFORMATION WHICH MAY BE DESIRED IS THE RESPONSIBILITY OF THE CONTRACTOR.

- NOTE: SPT - SPLIT SPOON SAMPLING
- TCP - TEXAS CONE PENETRATOR TEST
- AUG - AUGUR CUTTING SAMPLE
- LL - LIQUID LIMIT
- PL - PLASTIC LIMIT

- <#200 - PERCENT PASSING #200 SIEVE
- W% - MOISTURE CONTENT
- N - NUMBER OF BLOWS PER 12 INCHES
- ∇ DENOTES DEPTH TO OBSERVED GROUNDWATER

NOTE: WATER LEVEL ELEVATIONS SHOWN WERE OBTAINED AT THE TIME THE BORINGS WERE DRILLED AND MAY FLUCTUATE THROUGHOUT THE YEAR.

GEOLOGIC STATEMENT

"DIVISION FOUR" OF THE "ENGINEERING CLASSIFICATION OF GEOLOGICAL MATERIALS", PUBLISHED BY THE OKLAHOMA DEPARTMENT OF TRANSPORTATION (ODOT) INDICATES THAT THE SITE IS UNDERLAIN BY THE HENNESSEY UNIT (PHY). THE GEOLOGIC UNIT IS DESCRIBED BELOW. THIS UNIT CONSISTS OF RED PLATY TO BLOCKY CLAY SHALES AND MUDSTONE. THE MUDSTONES ARE HARD AND APPEAR BLOCKY. THE RED CLAY SHALE OF THE HENNESSEY UNIT IS CHARACTERIZED BY NUMEROUS BANDS OF STREAKS OF WHITE OR LIGHT GREEN COLOR RANGING FROM A FEW INCHES TO FOUR FEET IN THICKNESS. THE TOTAL THICKNESS OF THE UNIT IS ABOUT 400 FEET. THE HENNESSEY UNIT OUTCROPS IN A 5- TO 15-MILE NORTH-SOUTH BAND ACROSS GRANT, GARFIELD, KINGFISHER, LOGAN, CANADIAN, AND OKLAHOMA COUNTIES IN DIVISION FOUR. TOPOGRAPHICALLY, THE UNIT IS NEAR LEVEL TO GENTLY ROLLING AND IS GENERALLY GRASS COVERED OR CULTIVATED.

3/1/2024 2:25:30 PM H:\PROJECTS\12789_Cr\osarRoads_Phase_4\Bridges\Drawings\Phase 4 Bridges\Bridges\Bridges\Phase 4 Bridge D Foundation Report.dgn

PHASE 4		OKLAHOMA COUNTY	
BRIDGE "D"		I-240 OVER I-35	
FOUNDATION REPORT			
(SHEET 1 OF 3)			
STATE JOB NO. <u>09032(08)</u>		SHEET NO. <u>B101</u>	

DESIGN	
DRAWN	
CHECKED	
APPROVED	
SQUAD	POE

90% PLAN SUBMITTAL 2/29/2024

BORING NUMBER D-03
NORTHING: 142835.59
EASTING: 2150826.09
DATE DRILLED: 6/5/18

BORING NUMBER D-04
NORTHING: 142862.25
EASTING: 2151000.63
DATE DRILLED: 10/16/17

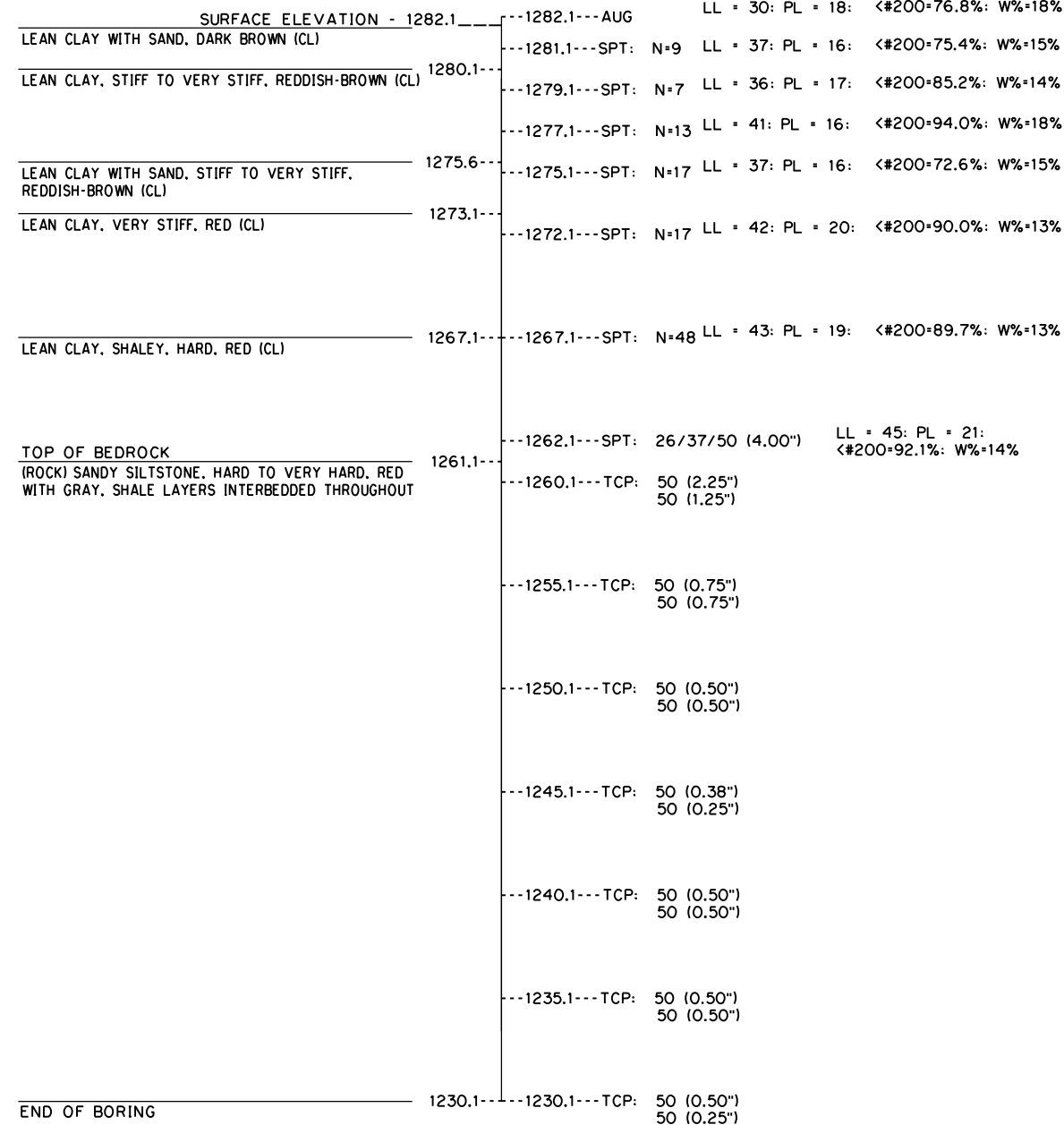
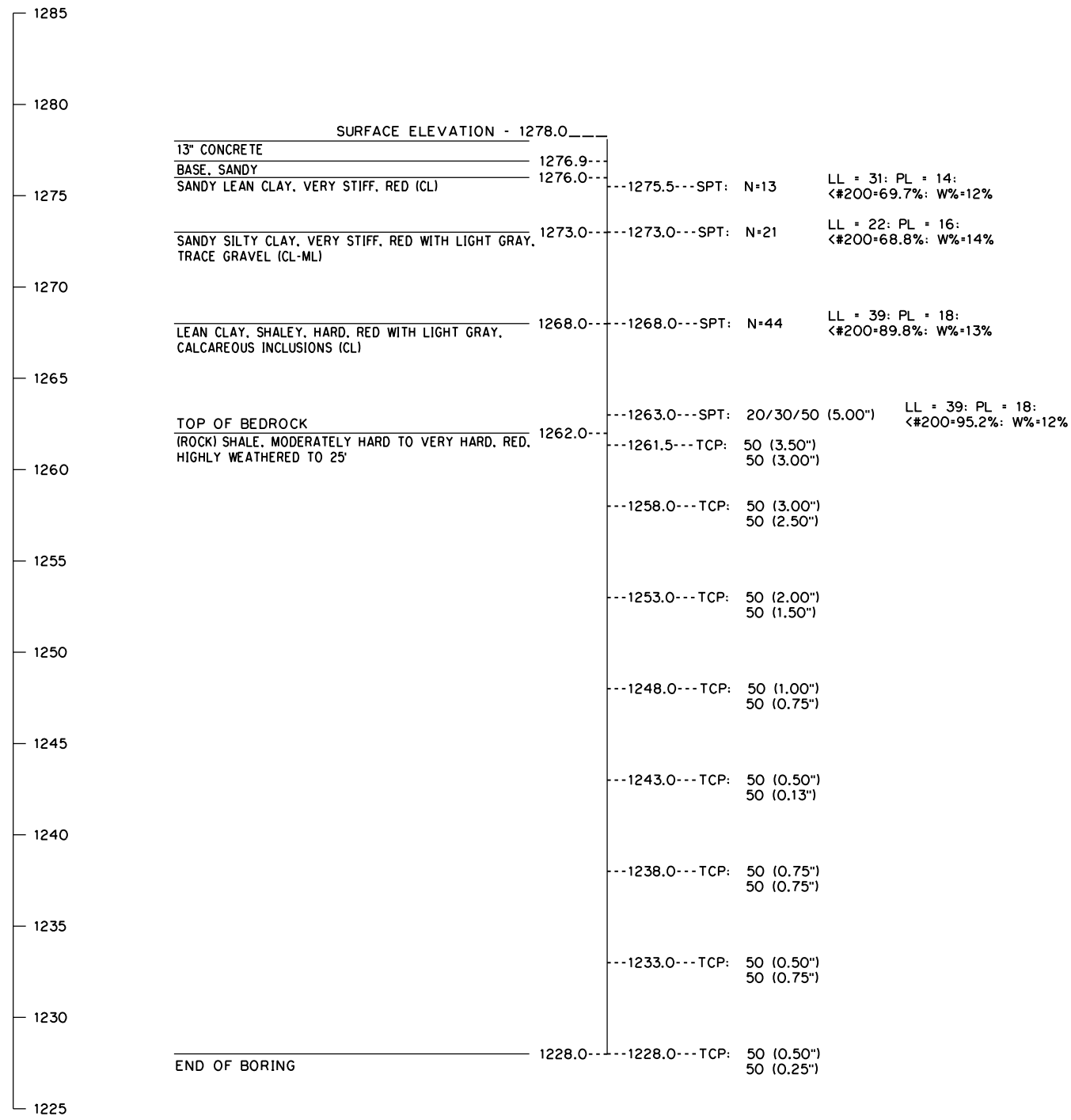

GEOTECHNICAL REPORT
ALL GEOTECHNICAL INFORMATION CONTAINED ON THIS SHEET IS COVERED BY THE ENGINEERING SEAL AFFIXED TO AN ORIGINAL GEOTECHNICAL ENGINEERING REPORT...

NOTE: SPT - SPLIT SPOON SAMPLING
TCP - TEXAS CONE PENETRATOR TEST
AUG - AUGUR CUTTING SAMPLE
LL - LIQUID LIMIT
PL - PLASTIC LIMIT
<#200 - PERCENT PASSING #200 SIEVE
W% - MOISTURE CONTENT
N - NUMBER OF BLOWS PER 12 INCHES
∇ DENOTES DEPTH TO OBSERVED GROUNDWATER

GEOLOGIC STATEMENT
"DIVISION FOUR" OF THE "ENGINEERING CLASSIFICATION OF GEOLOGICAL MATERIALS", PUBLISHED BY THE OKLAHOMA DEPARTMENT OF TRANSPORTATION (ODOT) INDICATES THAT THE SITE IS UNDERLAIN BY THE HENNESSEY UNIT (PHY)...

NOTE: WATER LEVEL ELEVATIONS SHOWN WERE OBTAINED AT THE TIME THE BORINGS WERE DRILLED AND MAY FLUCTUATE THROUGHOUT THE YEAR.

PROFESSIONAL SERVICE INDUSTRIES, INC.
intertek psi

Table with columns for DESIGN, DRAWN, CHECKED, APPROVED, SQUAD, POE.

PHASE 4 OKLAHOMA COUNTY BRIDGE "D" 1-240 OVER I-35
FOUNDATION REPORT (SHEET 2 OF 3)
STATE JOB NO. 09032(08) SHEET NO. B102

3/1/2024 2:25:31 PM H:\PROJECTS\2789_CrossRoads_Phase 4\Bridges\Drawings\Ph4 Bridges\Bridges D Foundation Report.dgn

BORING NUMBER D-05
NORTHING: 142835.49
EASTING: 2150987.41
DATE DRILLED: 5/3/17

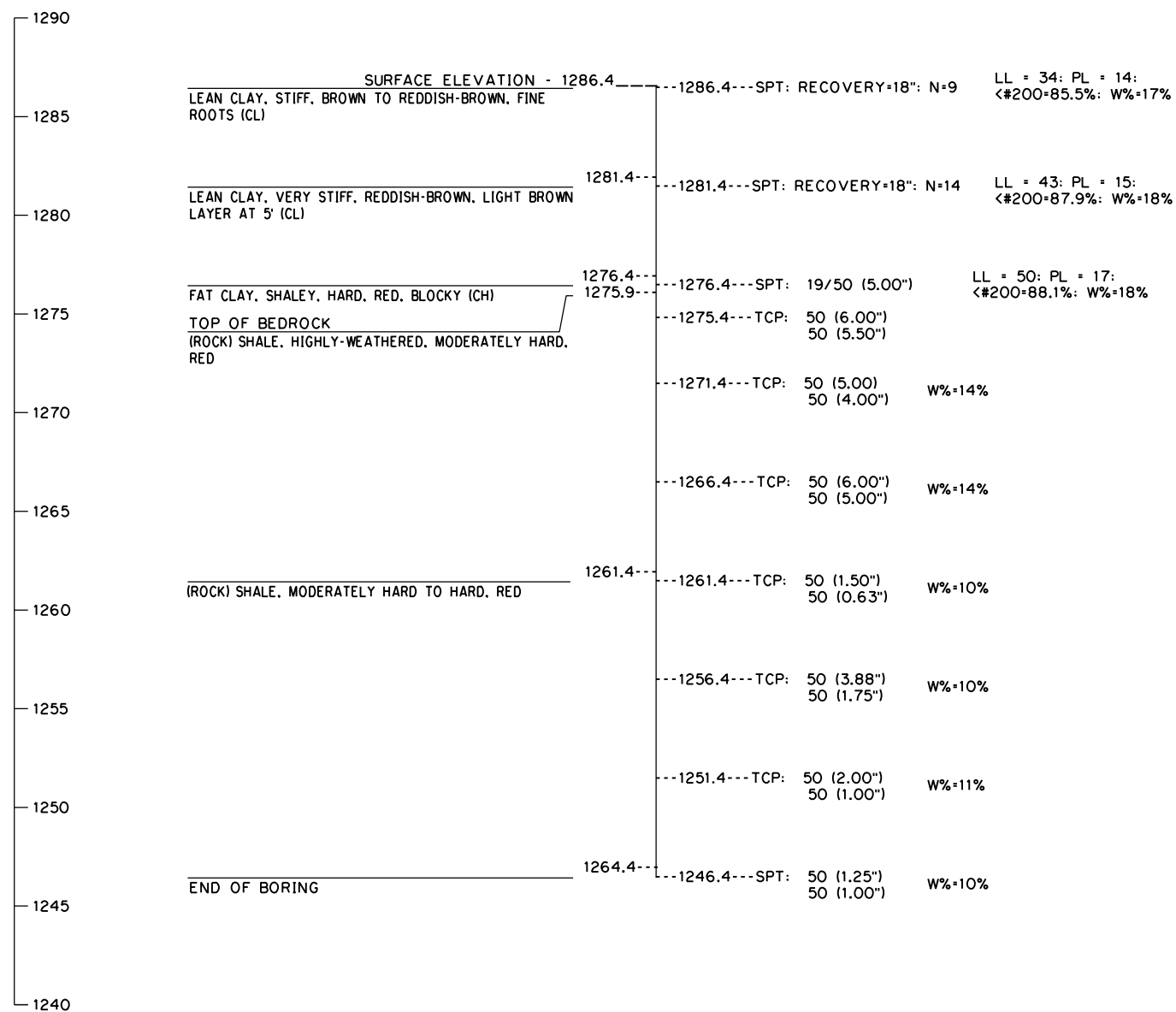

GEOLOGIC STATEMENT

"DIVISION FOUR" OF THE "ENGINEERING CLASSIFICATION OF GEOLOGICAL MATERIALS", PUBLISHED BY THE OKLAHOMA DEPARTMENT OF TRANSPORTATION (ODOT) INDICATES THAT THE SITE IS UNDERLAIN BY THE HENNESSEY UNIT (PHY). THE GEOLOGIC UNIT IS DESCRIBED BELOW. THIS UNIT CONSISTS OF RED PLATY TO BLOCKY CLAY SHALES AND MUDSTONE. THE MUDSTONES ARE HARD AND APPEAR BLOCKY. THE RED CLAY SHALE OF THE HENNESSEY UNIT IS CHARACTERIZED BY NUMEROUS BANDS OF STREAKS OF WHITE OR LIGHT GREEN COLOR RANGING FROM A FEW INCHES TO FOUR FEET IN THICKNESS. THE TOTAL THICKNESS OF THE UNIT IS ABOUT 400 FEET. THE HENNESSEY UNIT OUTCROPS IN A 5- TO 15-MILE NORTH-SOUTH BAND ACROSS GRANT, GARFIELD, KINGFISHER, LOGAN, CANADIAN, AND OKLAHOMA COUNTIES IN DIVISION FOUR. TOPOGRAPHICALLY, THE UNIT IS NEAR LEVEL TO GENTLY ROLLING AND IS GENERALLY GRASS COVERED OR CULTIVATED.

GEOTECHNICAL REPORT

ALL GEOTECHNICAL INFORMATION CONTAINED ON THIS SHEET IS COVERED BY THE ENGINEERING SEAL AFFIXED TO AN ORIGINAL GEOTECHNICAL ENGINEERING REPORT THAT HAS BEEN STAMPED AND SEALED BY A PROFESSIONAL ENGINEER LICENSED IN OKLAHOMA. TO OBTAIN A COPY OF THE COMPLETE REPORT, CONTACT THE ODOT OFFICE ENGINEER AT (405) 521-2625. THE CONTRACTOR SHOULD BE FULLY AWARE OF THE SITE CONDITIONS PRIOR TO BEGINNING WORK. ANY ADDITIONAL GEOTECHNICAL INFORMATION WHICH MAY BE DESIRED IS THE RESPONSIBILITY OF THE CONTRACTOR.

NOTE: WATER LEVEL ELEVATIONS SHOWN WERE OBTAINED AT THE TIME THE BORINGS WERE DRILLED AND MAY FLUCTUATE THROUGHOUT THE YEAR.

NOTE: SPT - SPLIT SPOON SAMPLING
TCP - TEXAS CONE PENETRATOR TEST
AUG - AUGUR CUTTING SAMPLE
LL - LIQUID LIMIT
PL - PLASTIC LIMIT

<#200 - PERCENT PASSING #200 SIEVE
W% - MOISTURE CONTENT
N - NUMBER OF BLOWS PER 12 INCHES
∇ DENOTES DEPTH TO OBSERVED GROUNDWATER

3/1/2024 2:25:32 PM H:\PROJECTS\2789_CrossRoads_Phase 4\Bridges\Drawings\Ph4 Bridges\Bridges\Bridges D Foundation Report.dgn

PROFESSIONAL SERVICE INDUSTRIES, INC.



DESIGN	
DRAWN	
CHECKED	
APPROVED	
SQUAD	POE

PHASE 4 OKLAHOMA COUNTY

BRIDGE "D" I-240 OVER I-35

FOUNDATION REPORT
(SHEET 3 OF 3)

STATE JOB NO. 09032(08) SHEET NO. B103

72"DIA. DRILLED SHAFTS SHALL BE CONSTRUCTED IN ALTERNATING SEQUENCE. DRILLED SHAFTS THAT ARE ADJACENT TO EACH OTHER SHALL NOT BE CONSTRUCTED IN THE SAME SEQUENCE. DO NOT EXCAVATE FOR ADJACENT DRILLED SHAFTS UNTIL THE PRIOR SEQUENCE OF SHAFTS HAS BEEN POURED AND ATTAINED A COMPRESSIVE STRENGTH OF 3 KSI.

NOTE: ABUTMENT PILES SHALL BE ORIENTED SUCH THAT THE FACE OF THE PILE WEB IS PARALLEL WITH THE FACE OF THE BRIDGE SEAT.

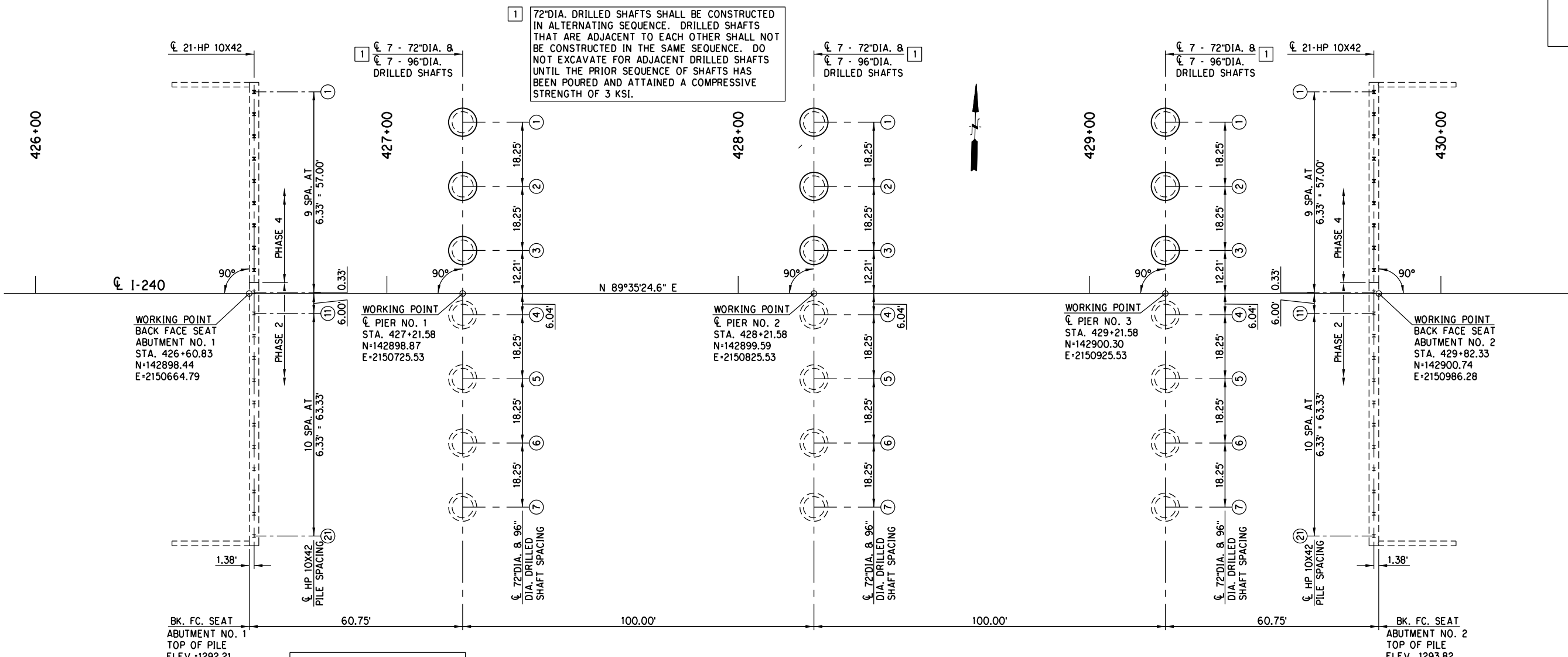

SUBSTRUCTURE STAKING DIAGRAM

3/1/2024 2:25:34 PM H:\PROJECTS\2789_CrossRoads_Phase 4\Bridges\Drawings\Ph4 Bridges\Bridges\Bridg D 0903208 P4 Bridge D Staking.dgn

PHASE 4		OKLAHOMA COUNTY	
BRIDGE "D"		I-240 OVER I-35	
DESIGN		SUBSTRUCTURE LAYOUT	
DRAWN			
CHECKED			
APPROVED			
SQUAD	POE	STATE JOB NO. 09032108) SHEET NO. B104	

NOTE: THE CONTRACTOR MAY PLACE CONCRETE AGAINST THE LIMITS OF EXCAVATION IF THE MATERIAL IS EXCAVATED TO THE NEAT LINES OF THE ABUTMENT AND APPROVED BY THE ENGINEER. IF NECESSARY, USE FORMS ON THE BACK VERTICAL FACE OF THE ABUTMENT AND REMOVE FORMS AFTER CONCRETE HARDENS. IF THE CONTRACTOR CHOOSES TO PLACE CONCRETE AGAINST THE SOIL, THE DEPARTMENT WILL PAY FOR SUBSTRUCTURE EXCAVATION COMMON IN ACCORDANCE WITH THE DIAGRAM SHOWN ON THE PLANS.

NOTE: THE ENGINEER MAY ADJUST THE EXTENT, LOCATION AND DEPTH OF 6" NON-PERFORATED PIPE UNDERDRAIN DURING CONSTRUCTION. INCLUDE THE COST OF PIPE UNDERDRAIN COVER MATERIAL (BOTH FINE SAND AND COARSE), FILTER FABRIC, TRENCH EXCAVATION, STANDARD BEDDING MATERIAL, AND EQUIPMENT AND LABOR FOR THEIR INSTALLATION IN THE CONTRACT UNIT PRICE OF 6" PERFORATED PIPE UNDERDRAIN ROUND AND 6" NON-PERF. PIPE UNDERDRAIN ROUND. INSTALL AS SHOWN ON THE PLANS AND ON STD. PUD-3.

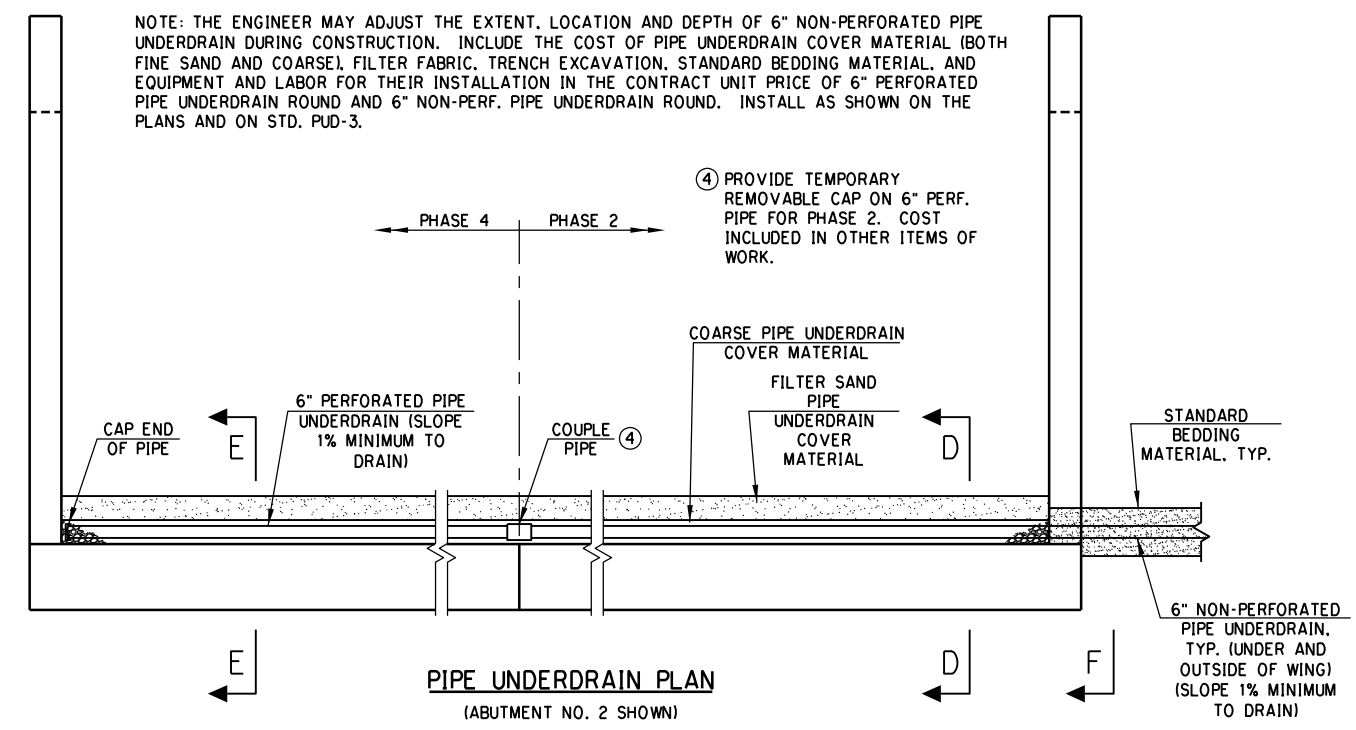
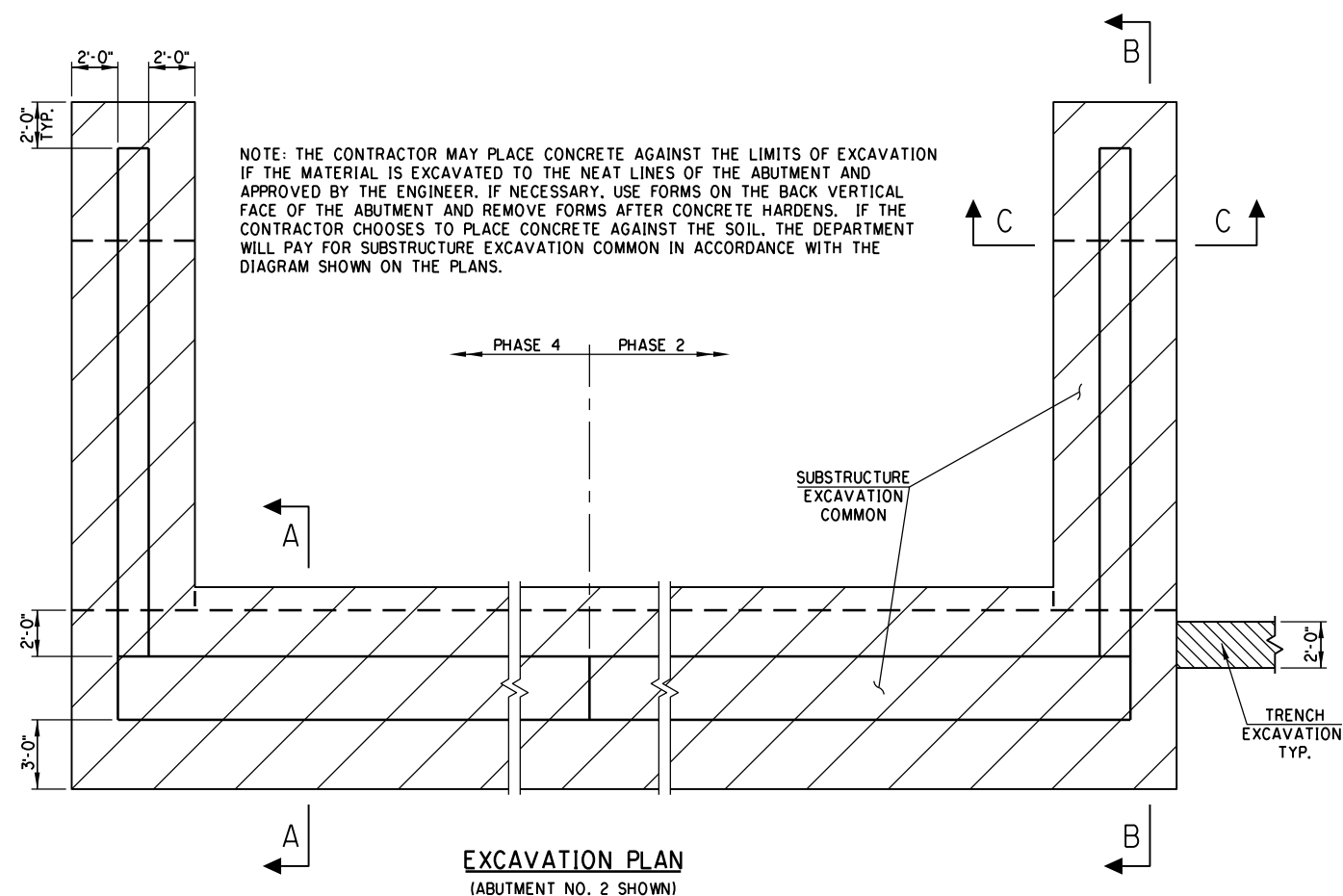

ABUT. NO. 1 - STA. 426+43.80 ELEV. 1298.68
ABUT. NO. 2 - STA. 429+99.91 ELEV. 1300.48

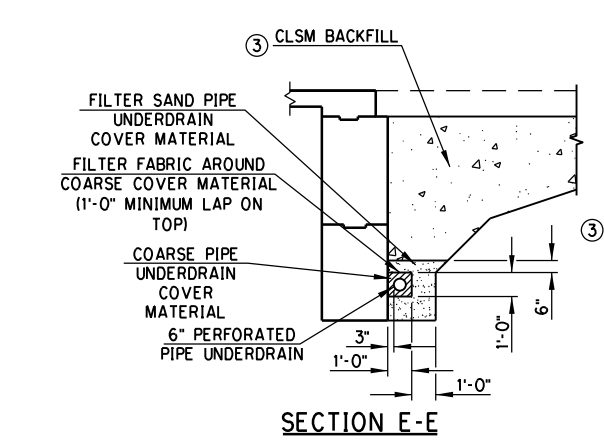
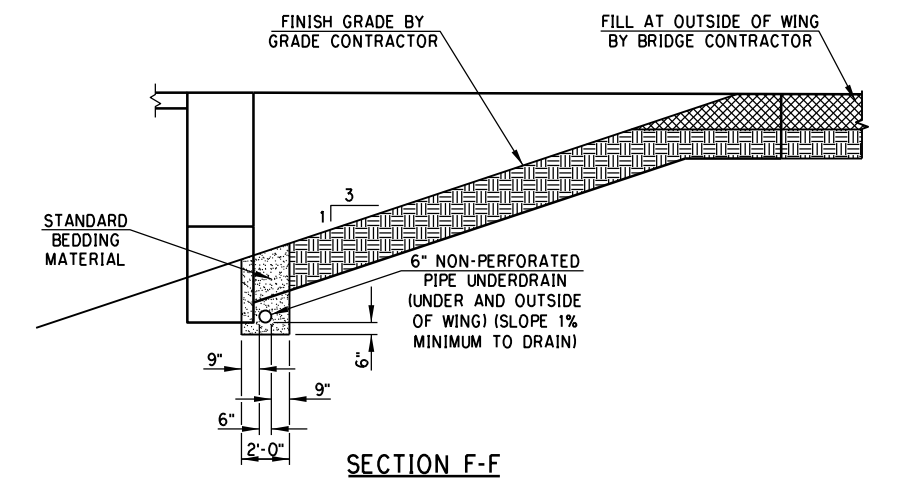
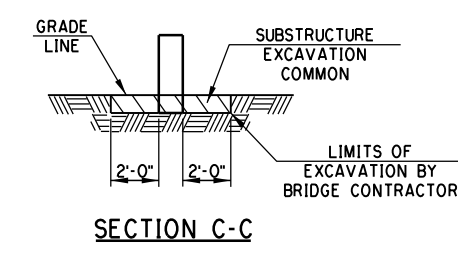
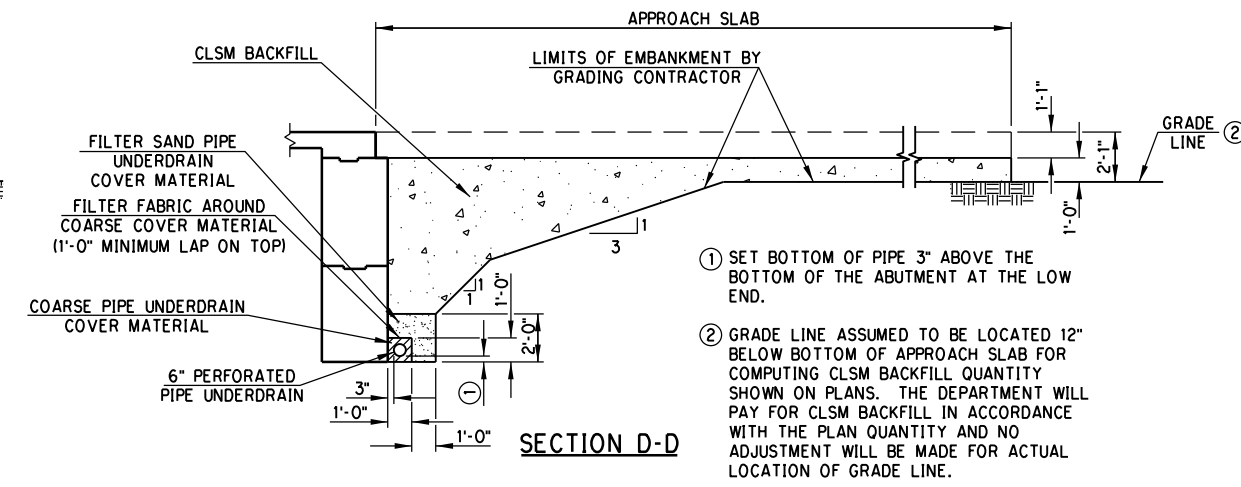
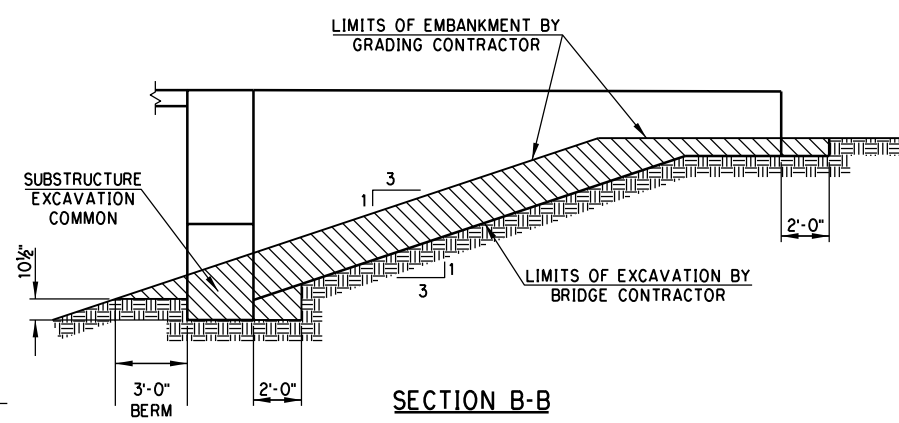
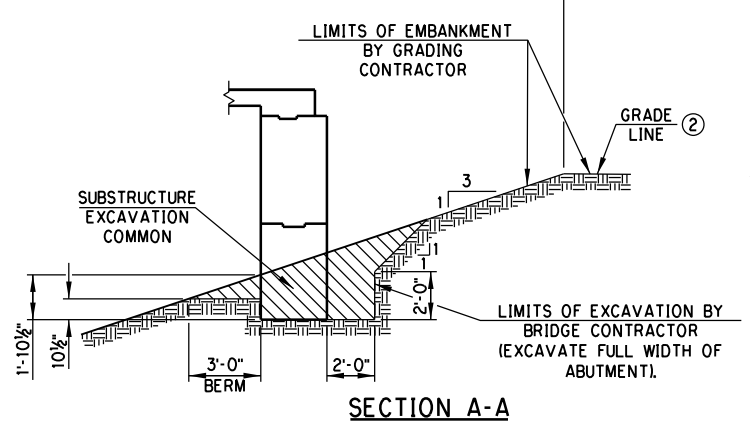

- ① SET BOTTOM OF PIPE 3" ABOVE THE BOTTOM OF THE ABUTMENT AT THE LOW END.
- ② GRADE LINE ASSUMED TO BE LOCATED 12" BELOW BOTTOM OF APPROACH SLAB FOR COMPUTING CLSM BACKFILL QUANTITY SHOWN ON PLANS. THE DEPARTMENT WILL PAY FOR CLSM BACKFILL IN ACCORDANCE WITH THE PLAN QUANTITY AND NO ADJUSTMENT WILL BE MADE FOR ACTUAL LOCATION OF GRADE LINE.

DO NOT PLACE CLSM BACKFILL UNTIL SUPERSTRUCTURE IS IN PLACE AND THE ABUTMENT WING CONCRETE HAS ATTAINED A STRENGTH OF 3000 P.S.I.

- ③ FOR EXTENTS OF CLSM BACKFILL, SEE SECTION D-D.

DESIGN		PHASE 4	OKLAHOMA COUNTY
DRAWN		BRIDGE "D"	1-240 OVER 1-35
CHECKED		ABUTMENT EXCAVATION AND UNDERDRAIN DETAILS	
APPROVED			
SQUAD	POE	STATE JOB NO. 09032108	SHEET NO. B105

3/1/2024 2:25:35 PM H:\PROJECTS\2789_CrossRoads\Phase 4\Bridges\Drawings\Bridges\Ph4 Bridges\Bridges\0903208 P4 Bridge D Excavation Diagram.dgn

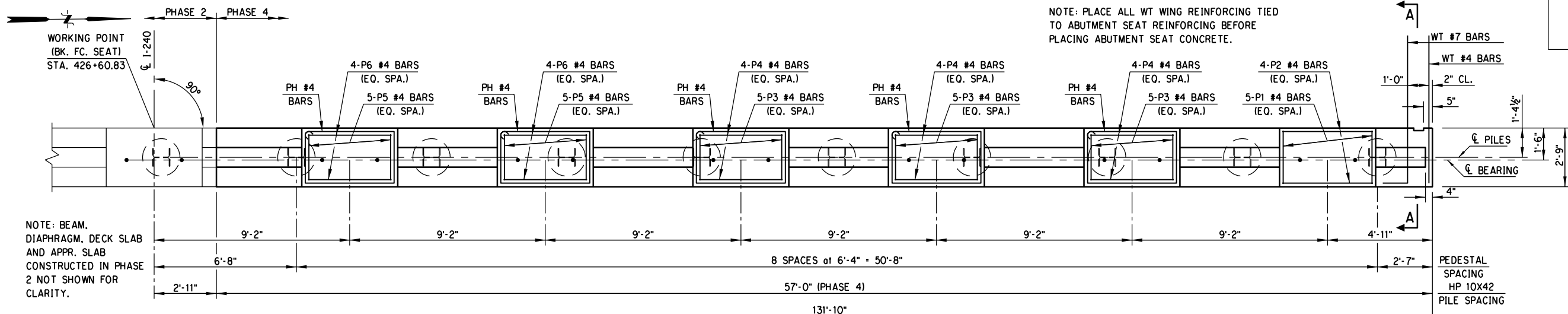

PLAN - ABUT. NO. 1 SEAT

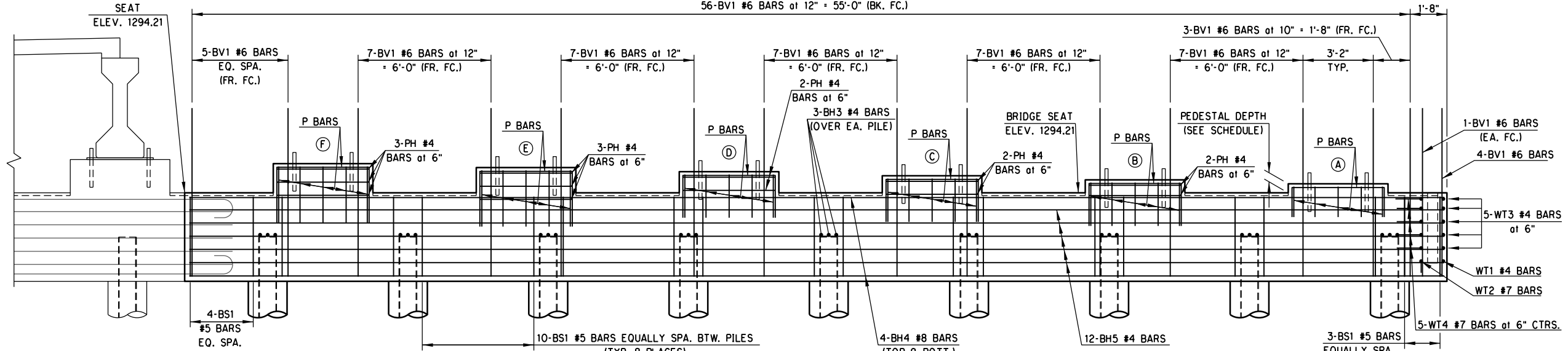

ELEVATION - ABUT. NO. 1 SEAT

PEDESTAL ELEVATION SCHEDULE

PEDESTAL	A	B	C	D	E	F
ELEVATION	1,264.62	1,294.80	1,294.99	1,295.17	1,295.35	1,295.54
DEPTH	4-7/8"	7-1/8"	9-5/16"	11-1/2"	1'-1 11/16"	1'-3 7/8"

ABUTMENT QUANTITIES

ITEM	UNIT	ABUT. NO. 1	ABUT. NO. 2	TOTAL
SUBSTRUCTURE EXCAVATION COMMON	C.Y.	40.00	40.00	80.00
CLSM BACKFILL	C.Y.	126.00	126.00	252.00
CLASS A CONCRETE	C.Y.	31.40	31.50	62.90
EPOXY COATED REINFORCING STEEL	LB.	5,090.00	5,090.00	10,180.00
PILES, FURNISHED (HP 10X42)	L.F.	225.00	297.00	522.00
PILES, DRIVEN (HP 10X42)	L.F.	225.00	297.00	522.00
WATER REPELLENT (VISUALLY INSPECTED)	S.Y.	21.00	21.00	42.00
6" PERFORATED PIPE UNDERDRAIN ROUND	L.F.	57.00	57.00	114.00

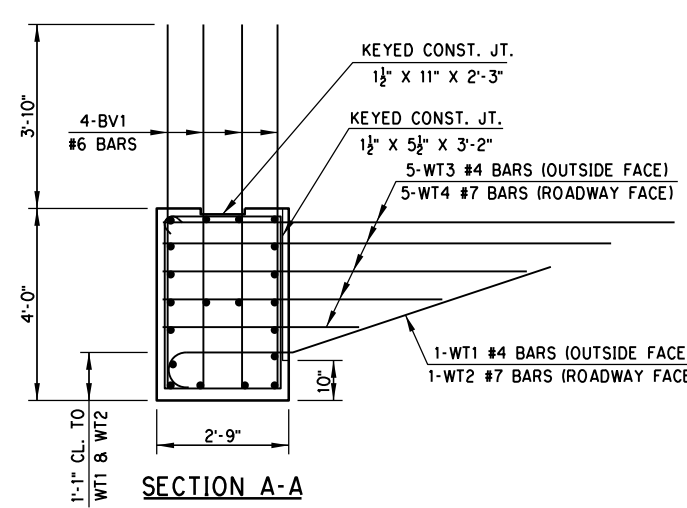

SECTION A-A

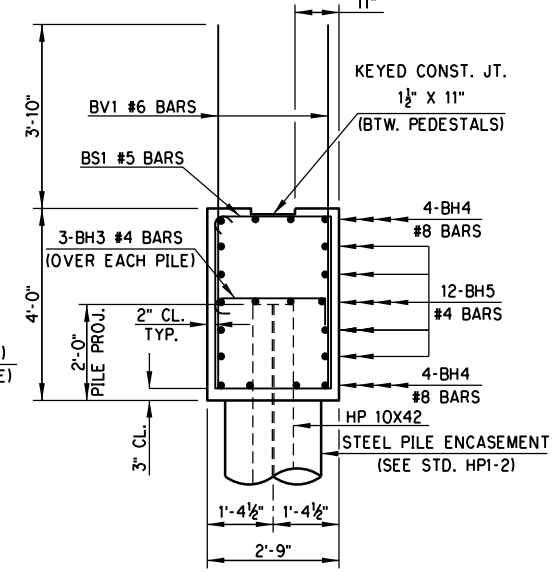

TYPICAL SECTION THRU SEAT

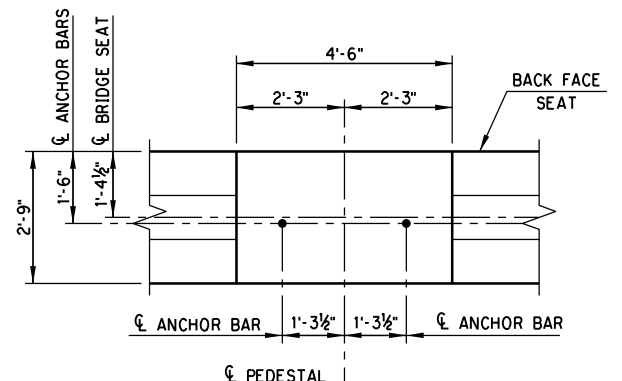

TYPICAL PEDESTAL & ANCHOR BAR LAYOUT

NOTE: FOR WATER REPELLENT TREATMENT DETAILS, SEE "SUPERSTRUCTURE DETAILS" SHEET 3 OF 4. FOR BAR LIST, SEE SHEET 3 OF 3.

DESIGN		PHASE 4	OKLAHOMA COUNTY
DRAWN		BRIDGE "D"	1-240 OVER 1-35
CHECKED		<p align="center">ABUTMENT DETAILS (SHEET 1 OF 3)</p>	
APPROVED			
SQUAD	POE		
		STATE JOB NO. 09032108) SHEET NO. B106	

3/1/2024 2:25:39 PM H:\PROJECTS\2789_CrossRoads_Phase 4\Bridges\Drawings\Phase 4\Bridges\Bridges\Bridges D Abutment.dgn

NOTE: PLACE ALL WT WING REINFORCING TIED TO ABUTMENT SEAT REINFORCING BEFORE PLACING ABUTMENT SEAT CONCRETE.

PHASE 4 PHASE 2

WORKING POINT
(BK. FC. SEAT)
STA. 429+82.33

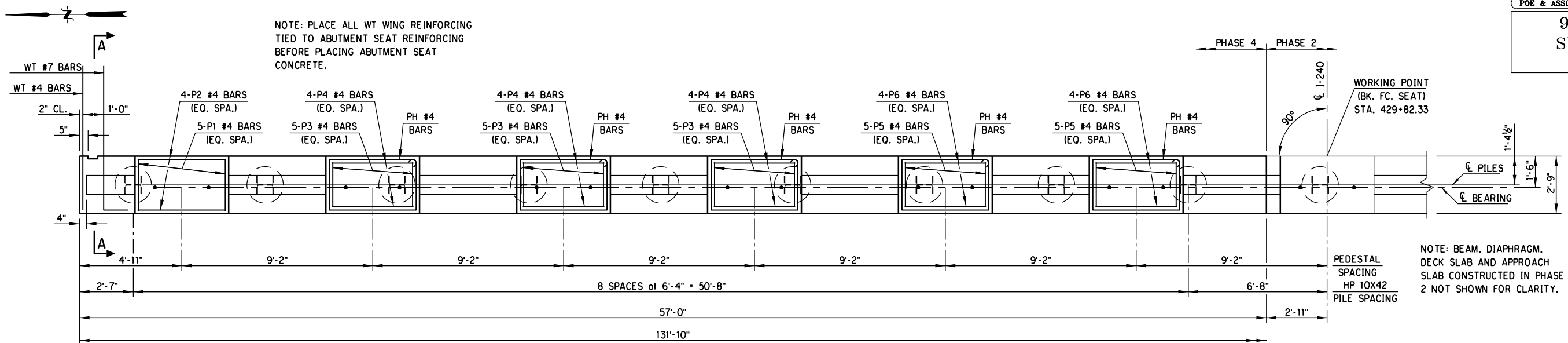

PLAN - ABUT. NO. 2 SEAT

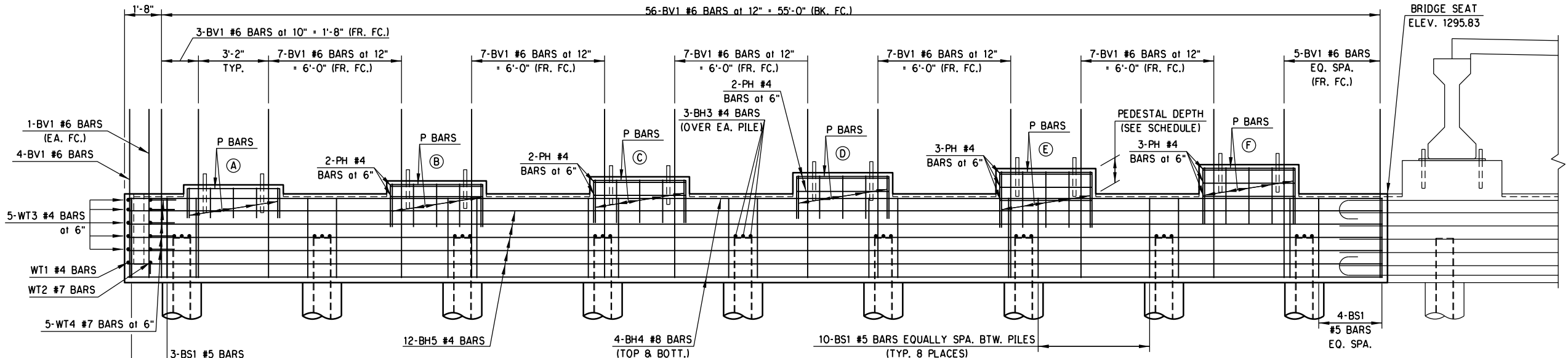

ELEVATION - ABUT. NO. 2 SEAT

PEDESTAL ELEVATION SCHEDULE						
PEDESTAL	A	B	C	D	E	F
ELEVATION	1,296.24	1,296.42	1,296.60	1,296.79	1,296.97	1,297.15
DEPTH	4-7/8"	7-1/8"	9-5/16"	11-1/2"	11'-1 11/16"	1'-3 7/8"

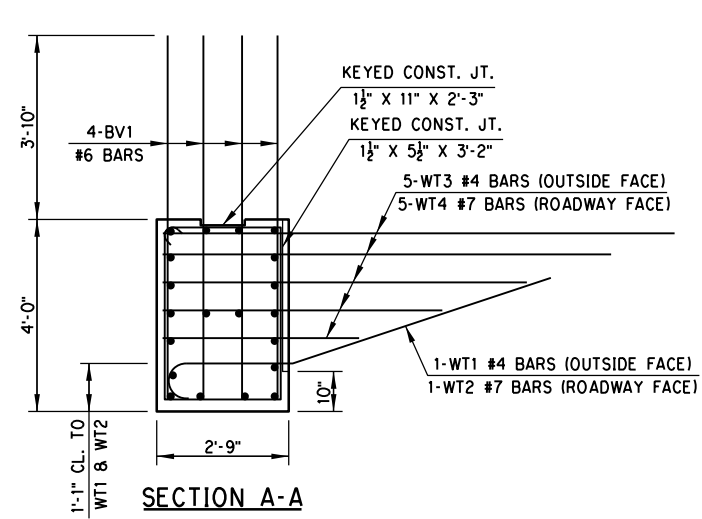

SECTION A-A

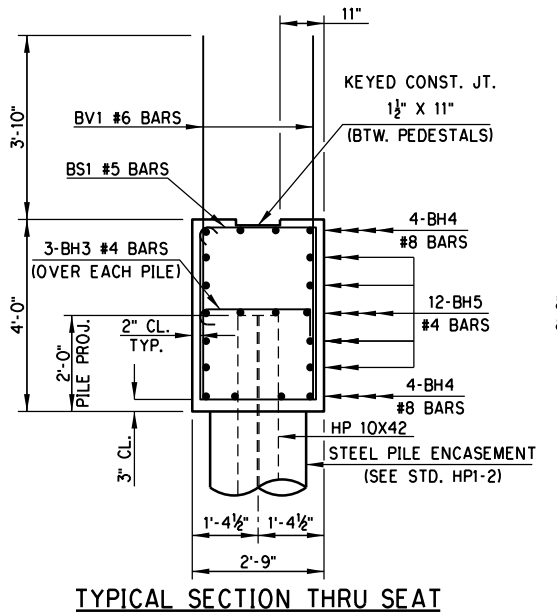

TYPICAL SECTION THRU SEAT

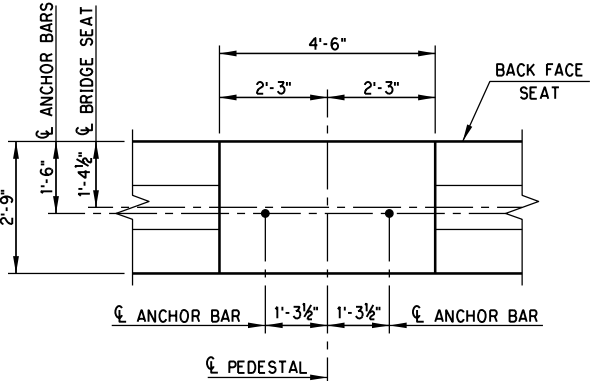

TYPICAL PEDESTAL & ANCHOR BAR LAYOUT

NOTE: FOR WATER REPELLENT TREATMENT DETAILS, SEE "SUPERSTRUCTURE DETAILS" SHEET 3 OF 4. FOR BAR LIST, SEE SHEET 3 OF 3.

DESIGN	
DRAWN	
CHECKED	
APPROVED	
SQUAD	POE

PHASE 4
BRIDGE "D"
OKLAHOMA COUNTY
1-240 OVER 1-35

ABUTMENT DETAILS
(SHEET 2 OF 3)

STATE JOB NO. 09032108 SHEET NO. B107

3/1/2024 2:25:40 PM H:\PROJECTS\2789_CrossRoads_Phase 4 Bridge Drawings\Phase 4 Bridge D Abutment.dgn

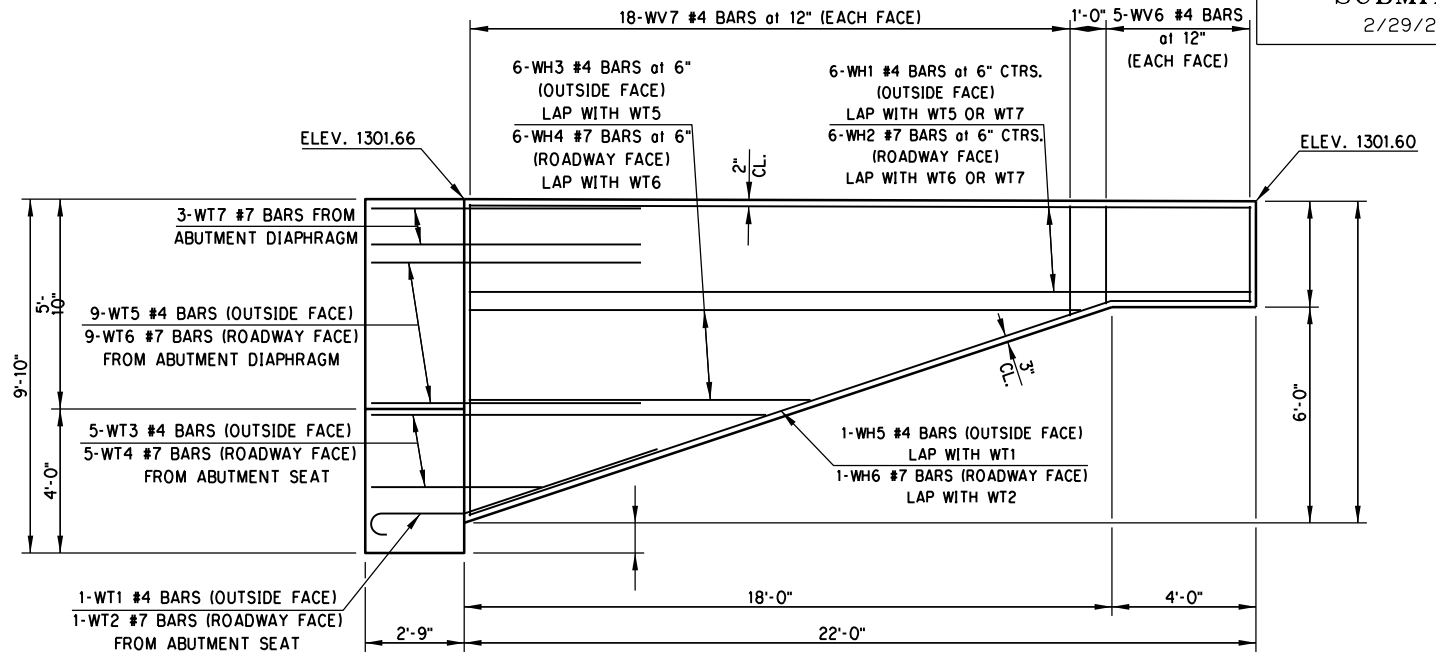
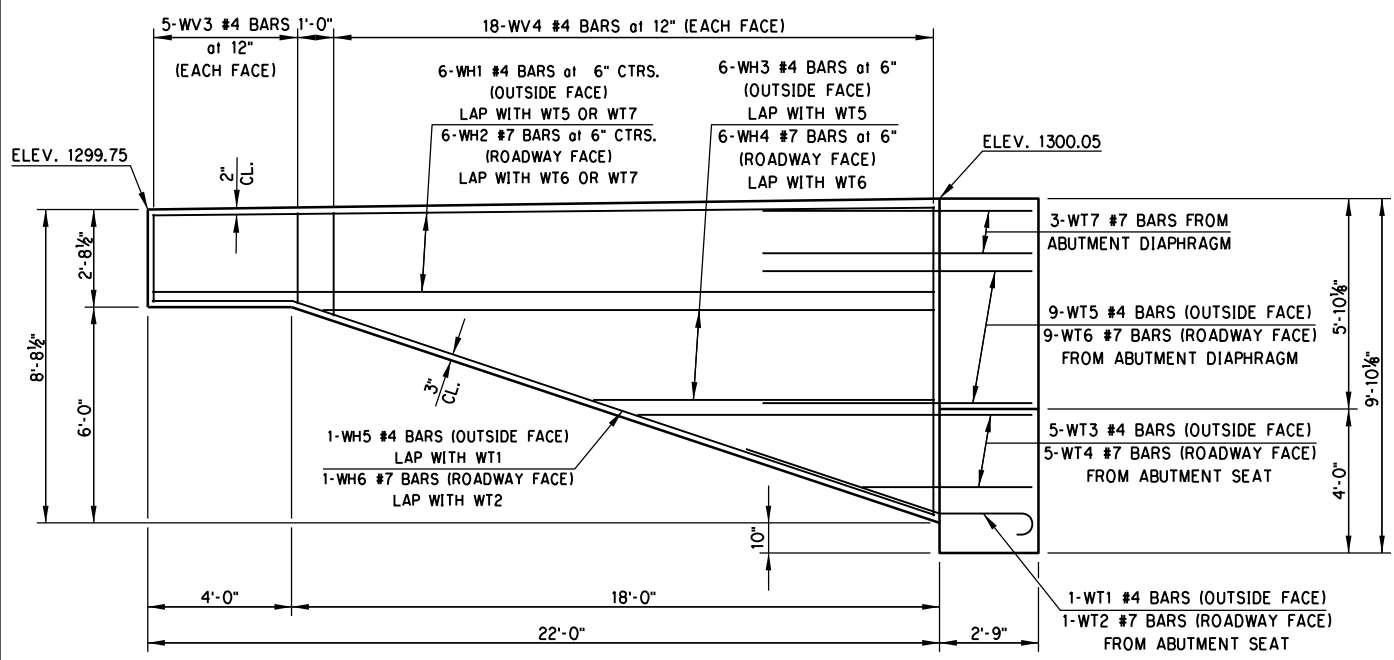

ABUT. NO. 1 NORTH WING ELEVATION

ABUT. NO. 2 NORTH WING ELEVATION

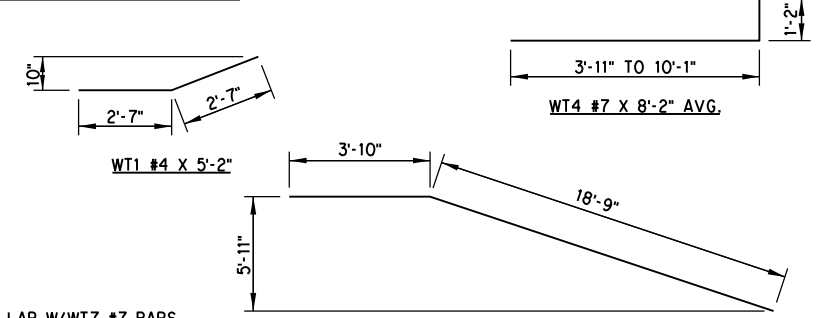

ABUTMENT NO. 1 SEAT BAR LIST
(EPOXY COATED REINFORCING)

MARK	SIZE	NO.	FORM	SPACING	LENGTH	VARIANCE
BH3	#4	27	BNT.	AS SHOWN	3'-7"	--
BH4	#8	8	STR.	EQ. SPA.	56'-8"	--
BH5	#4	12	STR.	EQ. SPA.	56'-8"	--
BS1	#5	87	BNT.	EQ. SPA.	12'-11"	--
BV1	#4	105	STR.	12" C/C	7'-7"	--
P1	#4	5	BNT.	EQ. SPA.	5'-1"	--
P2	#4	4	BNT.	EQ. SPA.	6'-10"	--
P3	#4	15	BNT.	EQ. SPA.	6'-2"	--
P4	#4	12	BNT.	EQ. SPA.	7'-11"	--
P5	#4	10	BNT.	EQ. SPA.	7'-4"	--
P6	#4	8	BNT.	EQ. SPA.	9'-1"	--
PH	#4	12	BNT.	6" C/C	13'-11"	--
WT1	#4	1	BNT.	AS SHOWN	5'-2"	--
WT2	#7	1	BNT.	AS SHOWN	9'-1"	--
WT3	#4	5	STR.	EQ. SPA.	7'-0" AVG.	3'-11" TO 10'-1"
WT4	#7	5	BNT.	EQ. SPA.	8'-2" AVG.	5'-1" TO 11'-3"
WH1	#4	6	STR.	6" C/C	21'-8"	--
WH2	#4	6	STR.	6" C/C	21'-8"	--
WH3	#4	6	STR.	6" C/C	12'-10" AVG.	9'-1" TO 16'-7"
WH4	#4	6	STR.	6" C/C	12'-10" AVG.	9'-1" TO 16'-7"
WH5	#4	1	BNT.	AS SHOWN	22'-7"	--
WH6	#7	1	BNT.	AS SHOWN	22'-7"	--
WV3	#4	10	STR.	12" C/C	2'-3"	--
WV4	#4	36	STR.	12" C/C	5'-7" AVG.	2'-8" TO 8'-6"

ABUTMENT NO. 2 SEAT BAR LIST
(EPOXY COATED REINFORCING)

MARK	SIZE	NO.	FORM	SPACING	LENGTH	VARIANCE
BH3	#4	27	BNT.	AS SHOWN	3'-7"	--
BH4	#8	8	STR.	EQ. SPA.	56'-8"	--
BH5	#4	12	STR.	EQ. SPA.	56'-8"	--
BS1	#5	87	BNT.	EQ. SPA.	12'-11"	--
BV1	#6	105	STR.	12" C/C	7'-7"	--
P1	#4	5	BNT.	EQ. SPA.	5'-1"	--
P2	#4	4	BNT.	EQ. SPA.	6'-10"	--
P3	#4	15	BNT.	EQ. SPA.	6'-2"	--
P4	#4	12	BNT.	EQ. SPA.	7'-11"	--
P5	#4	10	BNT.	EQ. SPA.	7'-4"	--
P6	#4	8	BNT.	EQ. SPA.	9'-1"	--
PH	#4	12	BNT.	6" C/C	13'-11"	--
WT1	#4	1	BNT.	AS SHOWN	5'-2"	--
WT2	#7	1	BNT.	AS SHOWN	9'-1"	--
WT3	#4	5	STR.	EQ. SPA.	7'-0" AVG.	3'-11" TO 10'-1"
WT4	#7	5	BNT.	EQ. SPA.	8'-2" AVG.	5'-1" TO 11'-3"
WH1	#4	6	STR.	6" C/C	21'-8"	--
WH2	#7	6	STR.	6" C/C	21'-8"	--
WH3	#4	6	STR.	6" C/C	12'-10" AVG.	9'-1" TO 16'-7"
WH4	#7	6	STR.	6" C/C	12'-10" AVG.	9'-1" TO 16'-7"
WH5	#4	1	BNT.	AS SHOWN	22'-7"	--
WH6	#7	1	BNT.	AS SHOWN	22'-7"	--
WV6	#4	10	STR.	12" C/C	2'-6"	--
WV7	#4	36	STR.	12" C/C	5'-8" AVG.	2'-10" TO 8'-6"

① 2 SETS OF 18

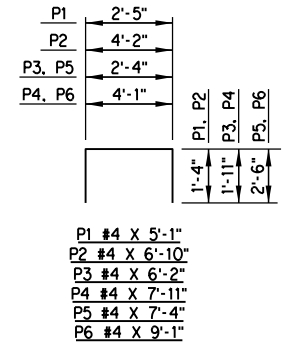
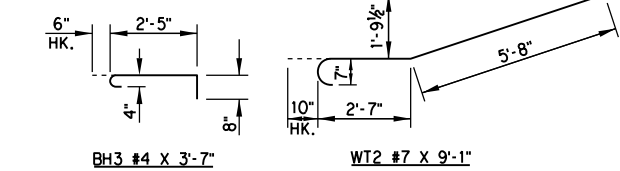
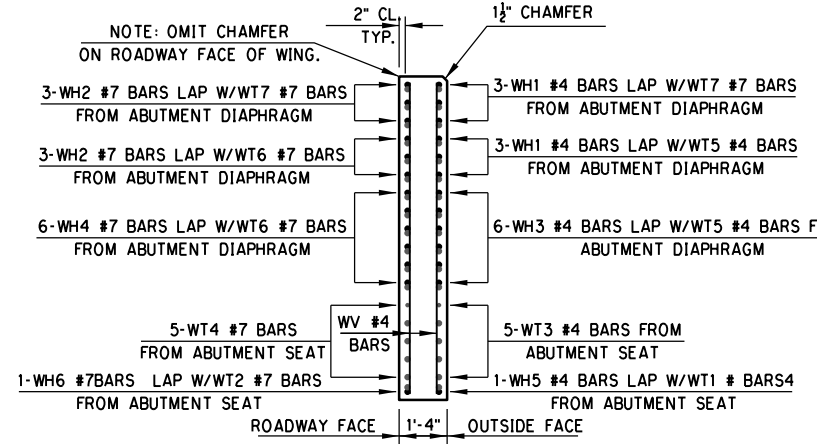

BAR BENDS
(BENT BAR DIMENSIONS ARE OUT TO OUT)

3/1/2024 2:25:42 PM H:\PROJECTS\2789_CrossRoads_Phase 4\Bridges\Drawings\Phase 4\Bridges\Drawings\Ph4 Bridges\Drawings\Abutment.dgn

PHASE 4 OKLAHOMA COUNTY
BRIDGE "D" 1-240 OVER I-35

DESIGN	
DRAWN	
CHECKED	
APPROVED	
SQUAD	POE

ABUTMENT DETAILS
(SHEET 3 OF 3)

STATE JOB NO. 09032108 SHEET NO. B108

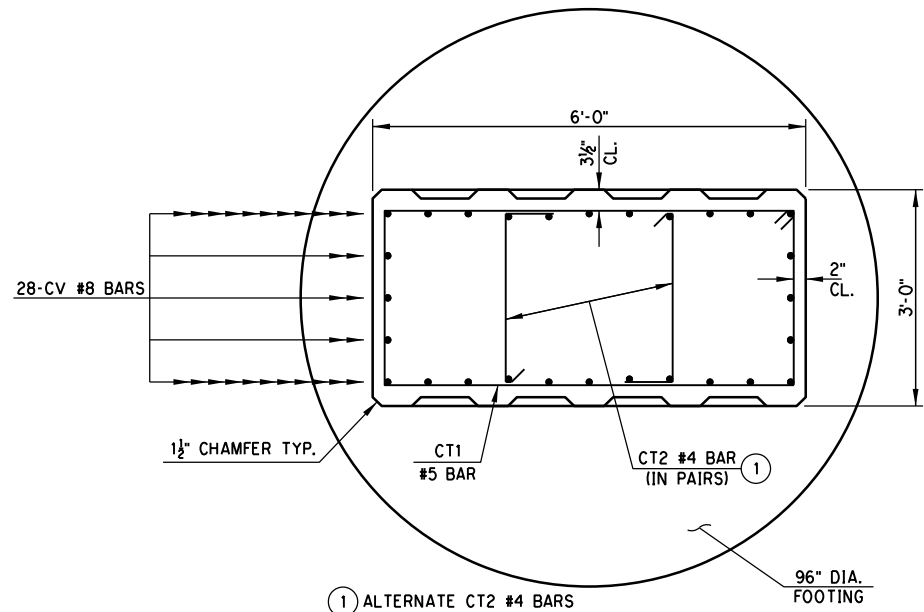

① ALTERNATE CT2 #4 BARS END TO END FOR EACH SUCCESSIVE ROW.

SECTION A-A

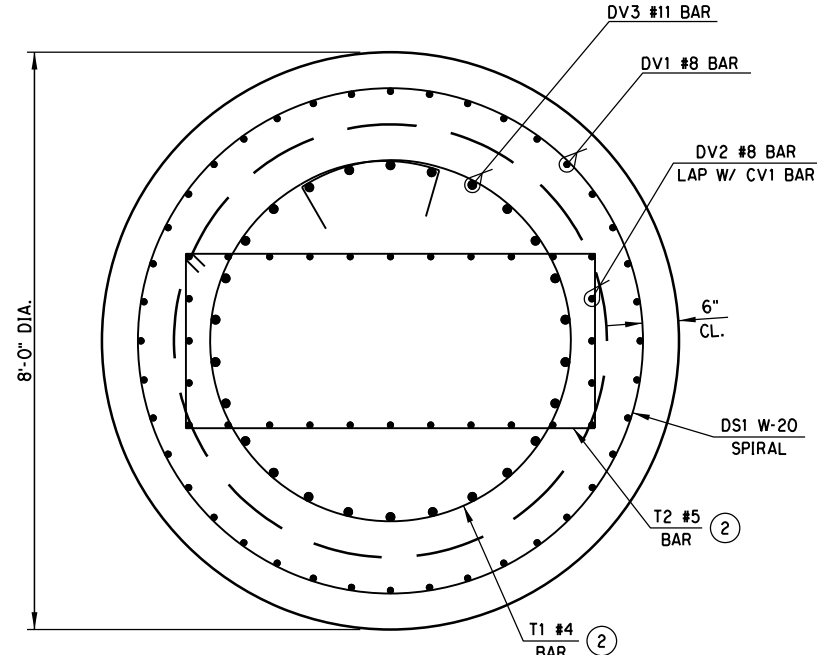

SECTION B-B

② ROTATE BARS 180 DEGREES FOR EACH SUCCESSIVE ROW.

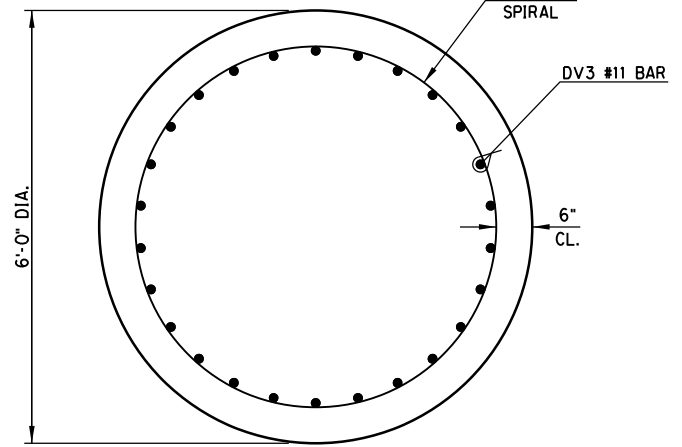

SECTION C-C

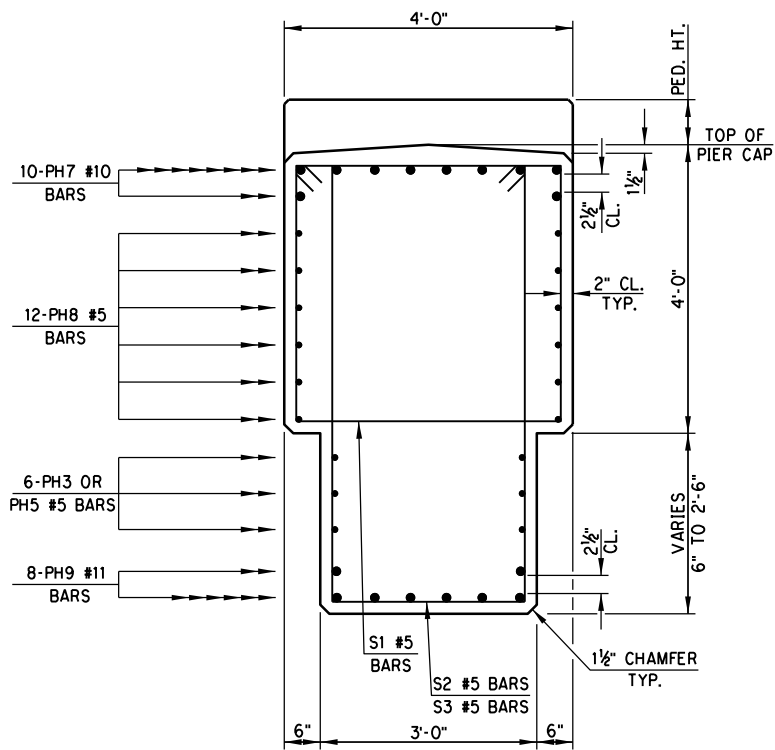

SECTION D-D

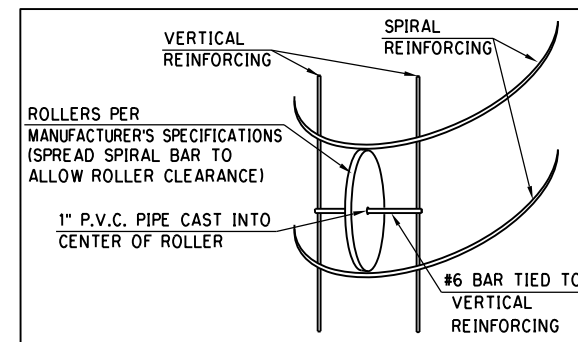

ROLLERS PER MANUFACTURER'S SPECIFICATIONS (SPREAD SPIRAL BAR TO ALLOW ROLLER CLEARANCE)

1" P.V.C. PIPE CAST INTO CENTER OF ROLLER

#6 BAR TIED TO VERTICAL REINFORCING

ROLLER INSTALLATION DETAIL

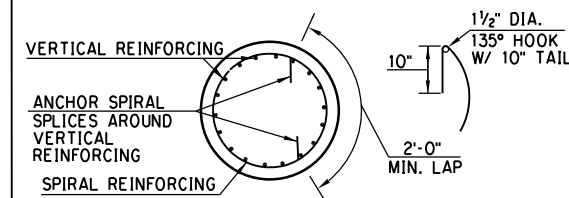

SPIRAL REINFORCING SPLICE DETAILS

NOTE: SPIRAL BARS SHALL CONFORM TO AASHTO M-32. SPIRAL BAR LENGTHS DO NOT INCLUDE LAP. IF LAP IS REQUIRED, THE LENGTH OF THE LAP SHALL BE AS SHOWN.

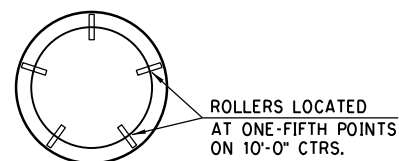

ROLLER PLACEMENT

ROLLER DETAILS

NOTE: REINFORCING CAGE CENTERING DEVICES SHALL CONSIST OF ROLLERS PLACED AT SPACING AS SHOWN AND HAVE THE CHARACTERISTICS AS INDICATED IN THE MANUFACTURER'S SPECIFICATIONS. SLAB BOLSTERS AND HIGH CHAIRS WILL BE ALLOWED BY THE DEPARTMENT.

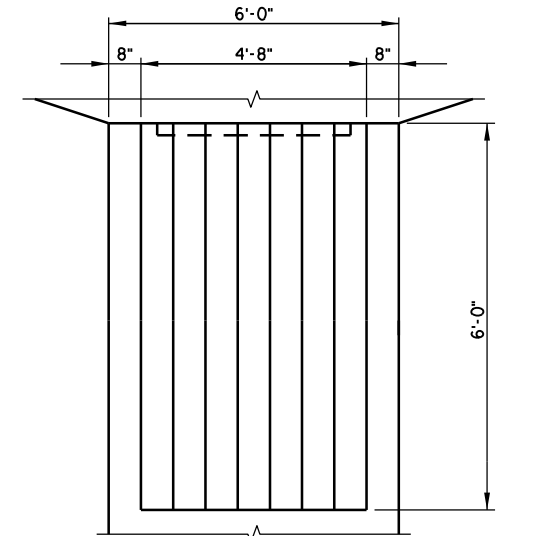

ELEVATION

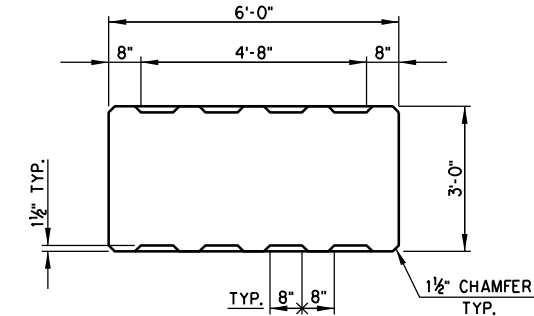

SECTION
FORM LINER DETAIL
(BOTH FACES OF ALL PIER COLUMNS)

DESIGN	
DRAWN	
CHECKED	
APPROVED	
SQUAD	POE

90% PLAN SUBMITTAL 2/29/2024

PIER NO. 1 BAR LIST (EPOXY COATED)

Table with 7 columns: MARK, SIZE, NO., FORM, SPACING, LENGTH, VARIANCE. Rows include CT1, CT2, CV1, DS1, DV1, DV2, P1, P2, P3, P4, PE1, PE2, PH3, PH5, PH6, PH7, PH8, PH9, PS1, PT1, PT2, S1, S2, S3, T1, T2.

PIER NO. 2 BAR LIST (EPOXY COATED)

Table with 7 columns: MARK, SIZE, NO., FORM, SPACING, LENGTH, VARIANCE. Rows include CT1, CT2, CV1, DS1, DV1, DV2, P1, P2, P3, P4, PE1, PE2, PH3, PH5, PH6, PH7, PH8, PH9, PS1, PT1, PT2, S1, S2, S3, T1, T2.

PIER NO. 3 BAR LIST (EPOXY COATED)

Table with 7 columns: MARK, SIZE, NO., FORM, SPACING, LENGTH, VARIANCE. Rows include CT1, CT2, CV2, DS1, DV1, DV2, P1, P2, P3, P4, PE1, PE2, PH3, PH5, PH6, PH7, PH8, PH9, PS1, PT1, PT2, S1, S2, S3, T1, T2.

72" DRILLED SHAFTS

Table with 7 columns: MARK, SIZE, NO., FORM, SPACING, LENGTH, VARIANCE. Rows include DS2, DV3.

72" DRILLED SHAFTS

Table with 7 columns: MARK, SIZE, NO., FORM, SPACING, LENGTH, VARIANCE. Rows include DS2, DV3.

72" DRILLED SHAFTS

Table with 7 columns: MARK, SIZE, NO., FORM, SPACING, LENGTH, VARIANCE. Rows include DS2, DV3.

- 5 2 SETS OF 3
7 INCLUDED IN THE CONTRACT UNIT PRICE OF DRILLED SHAFT
8 LENGTH SHOWN DOES NOT ACCOUNT FOR SPLICES. CONTRACTOR MAY ADD SPLICES AS NECESSARY, BUT PAYMENT WILL NOT BE MADE FOR EXTRA LENGTH REQUIRED FOR SPLICES.
9 4 SETS OF 3
10 6 SETS OF 13
14 LAP W/ PH1 FROM PHASE 2
15 LAP W/ PH2 FROM PHASE 3
16 LAP W/ PH4 FROM PHASE 4
NON-EPOXY COATED

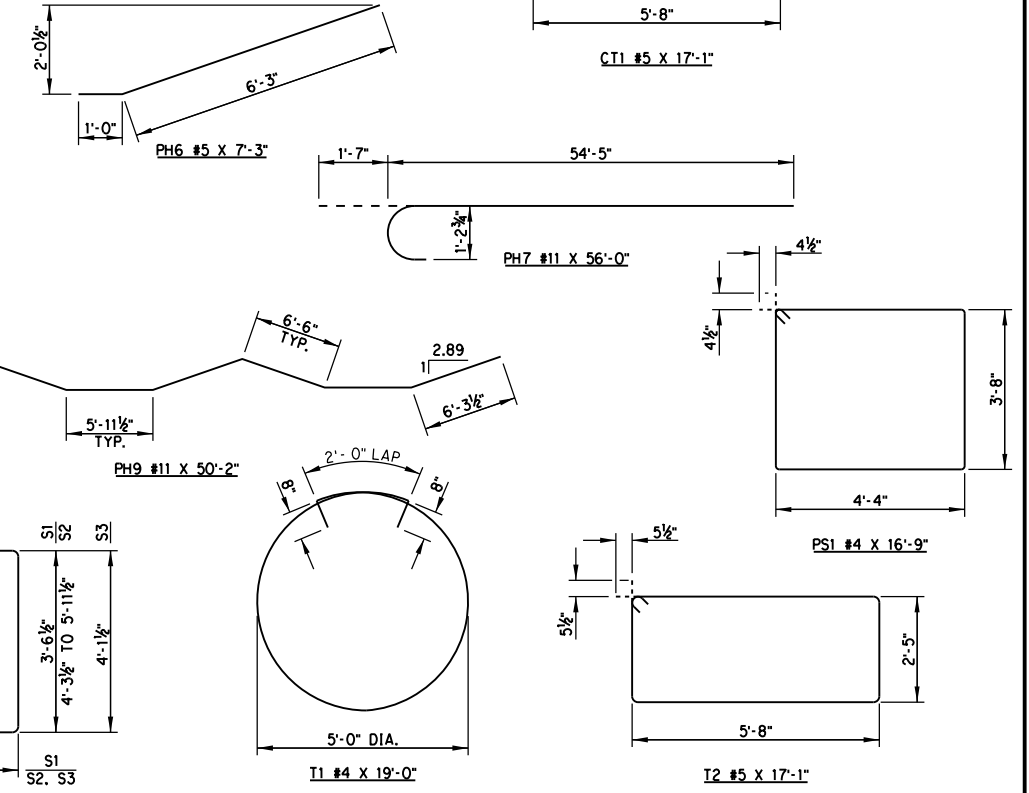
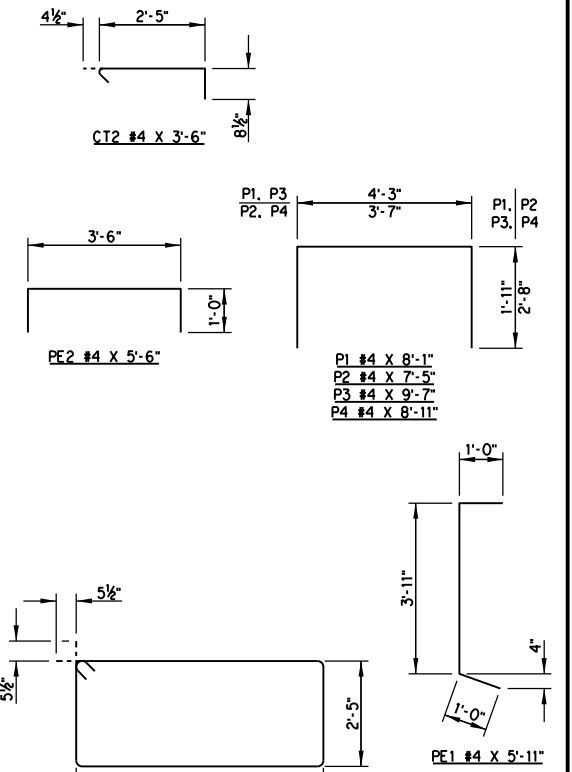

BAR BENDS (BENT BAR DIMENSIONS ARE OUT TO OUT)

3/1/2024 2:25:48 PM H:\PROJECTS\2789_CrossRoads_Phase 4\Bridges\Drawings\Ph4 Bridges\Bridges\0903208 P4 Bridge D Pier.dgn

NOTE: PIER CAP REINFORCEMENT NOT SHOWN FOR CLARITY.

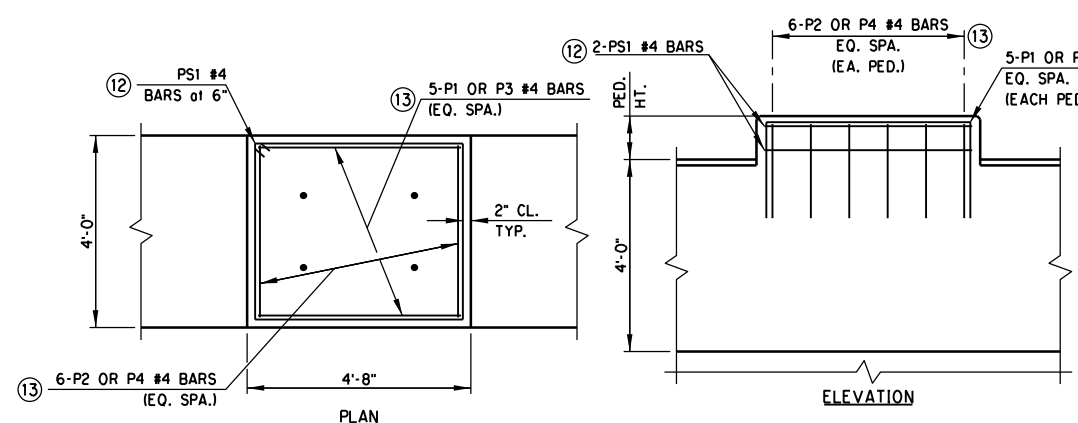

PEDESTAL REINFORCING DETAIL (TYPICAL AT EACH PEDESTAL)

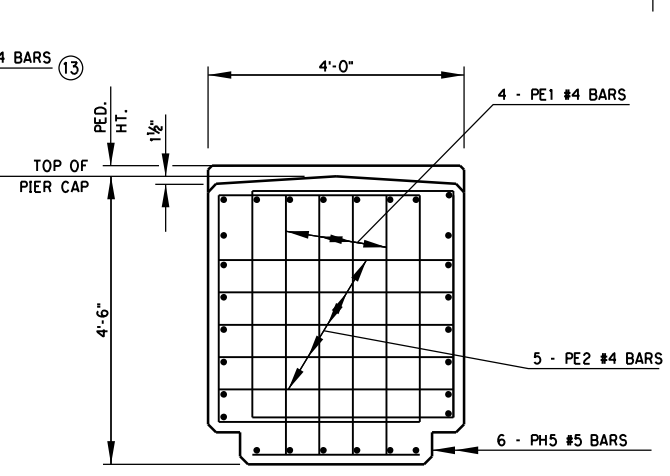

CAP END REINFORCING DETAIL (NORTH END)

- 12 3-PS1 #4 BARS REQUIRED FOR PED. HT. GREATER THAN 12".
2-PS1 #4 BARS REQUIRED FOR PED. HTS. BETWEEN 12" AND 6".
1-PS1 #4 BAR REQUIRED FOR PED. HT. LESS THAN 6".
13 P3 #4 AND P4 #4 BARS REQUIRED FOR PED. HTS. GREATER THAN 9".
P1 #4 AND P2 #4 BARS REQUIRED FOR THE REMAINING PEDESTALS.

Table with columns: DESIGN, DRAWN, CHECKED, APPROVED, SQUAD, POE.

PHASE 4 BRIDGE "D" OKLAHOMA COUNTY 1-240 OVER 1-35

PIER DETAILS (SHEET 3 OF 3)

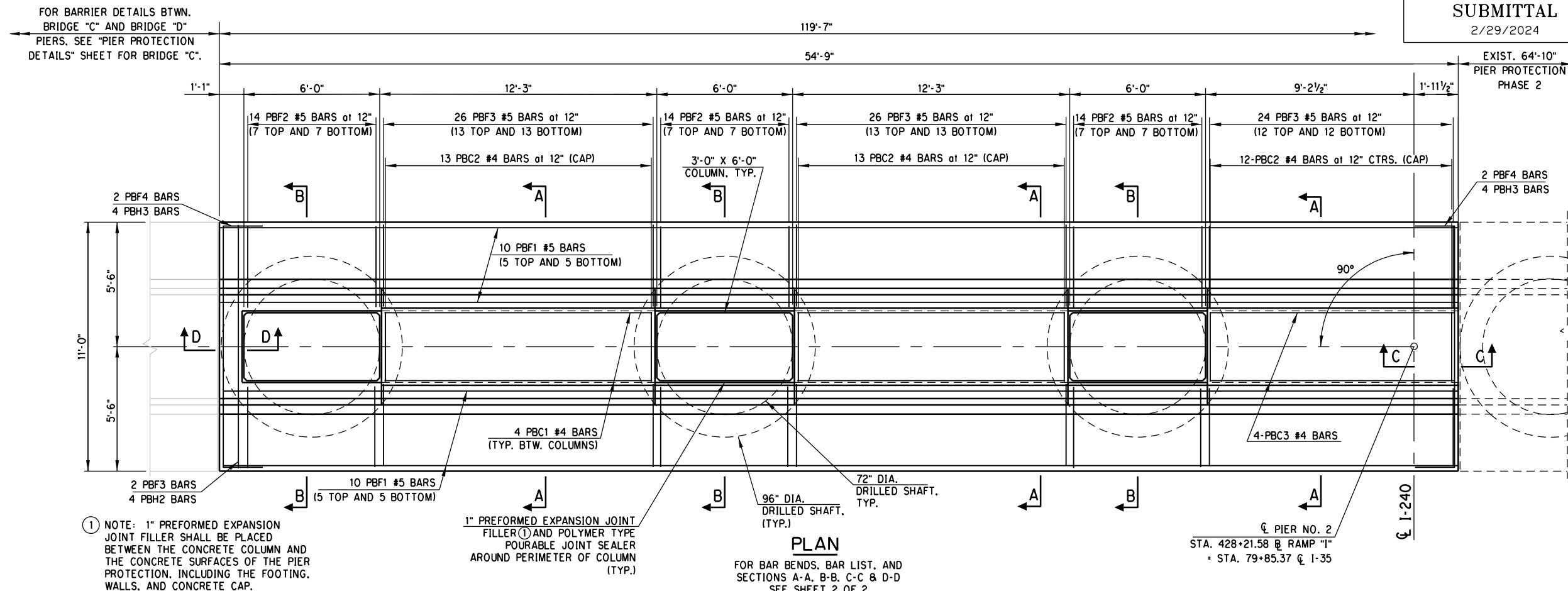

NOTE: 1" PREFORMED EXPANSION JOINT FILLER SHALL BE PLACED BETWEEN THE CONCRETE COLUMN AND THE CONCRETE SURFACES OF THE PIER PROTECTION, INCLUDING THE FOOTING, WALLS, AND CONCRETE CAP.

54'-9" PHASE 4

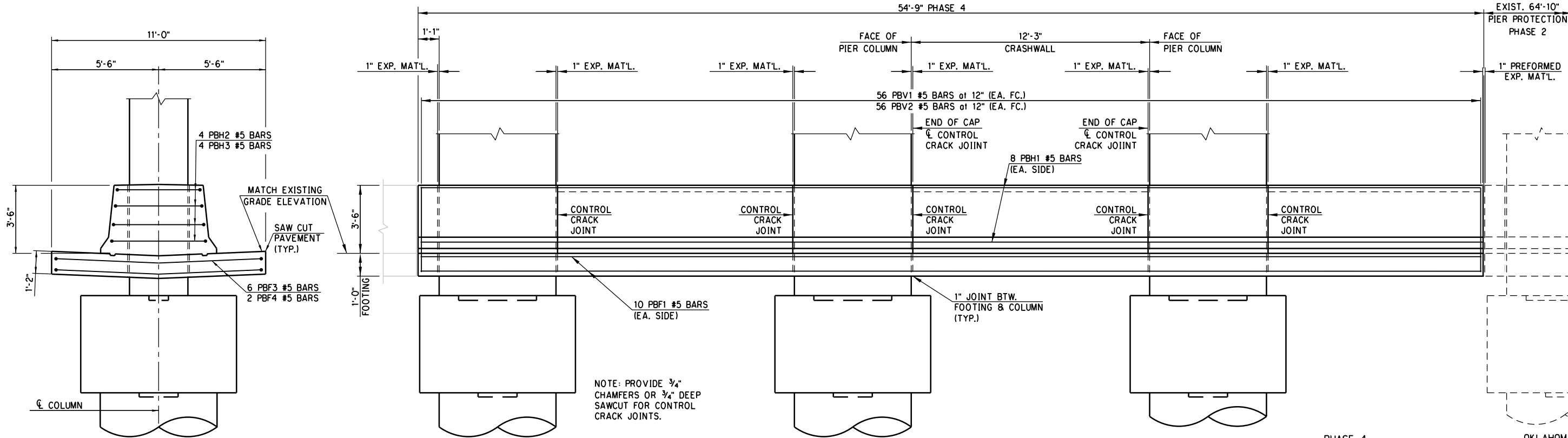

END ELEVATION AT NORTH END

ELEVATION

DESIGN		PHASE 4	OKLAHOMA COUNTY
DRAWN		BRIDGE "D"	I-240 OVER I-35
CHECKED		PIER PROTECTION DETAILS PIER NO. 2 (SHEET 1 OF 2)	
APPROVED			
SQUAD	POE		
		STATE JOB NO. 09032(08)	SHEET NO. B112

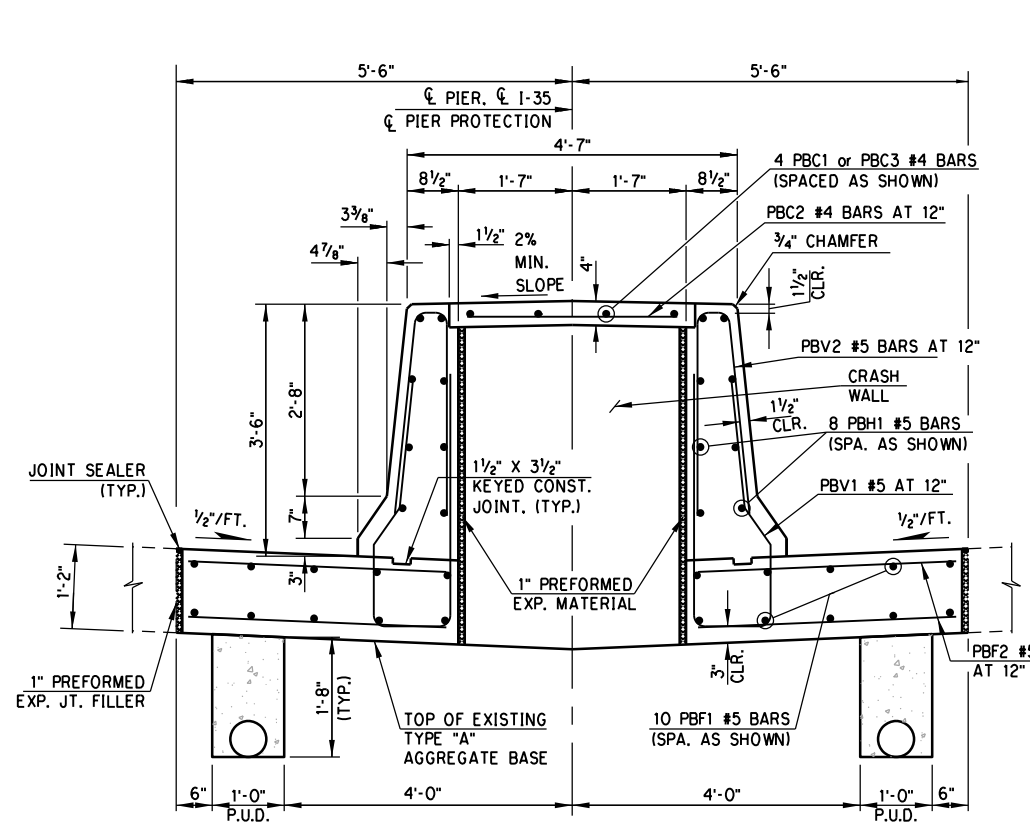

SECTION A-A
AT CRASH WALL

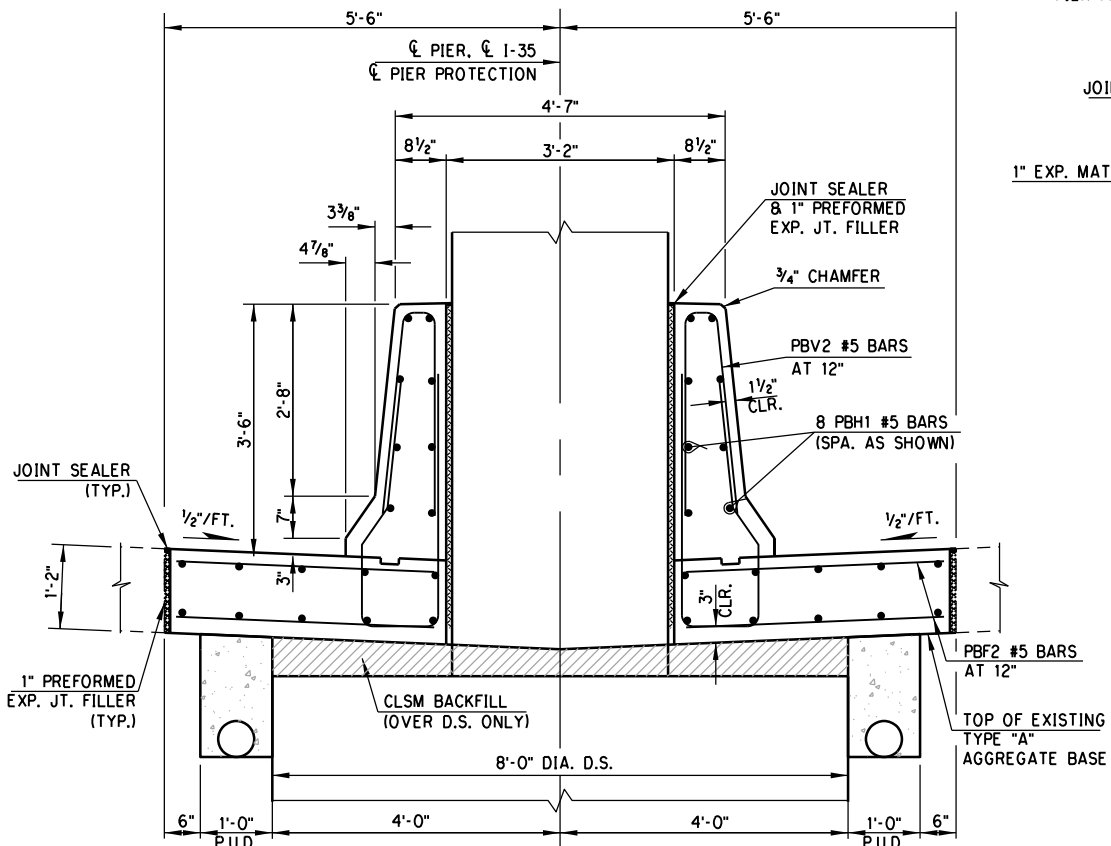

SECTION B-B
AT PIER

NOTE: COLUMN REINFORCEMENT NOT SHOWN FOR CLARITY.

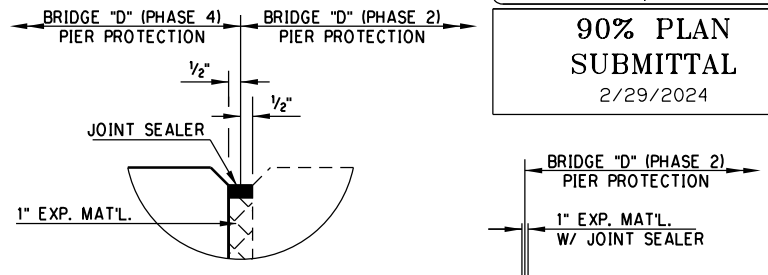

DETAIL "B"

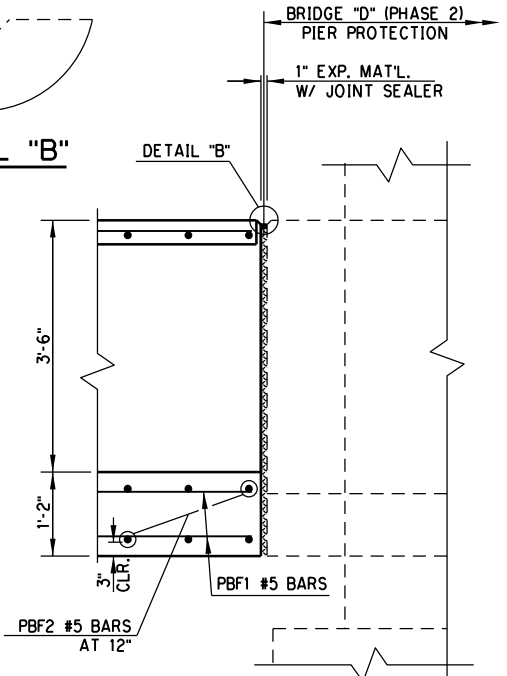

SECTION C-C
AT SOUTH END

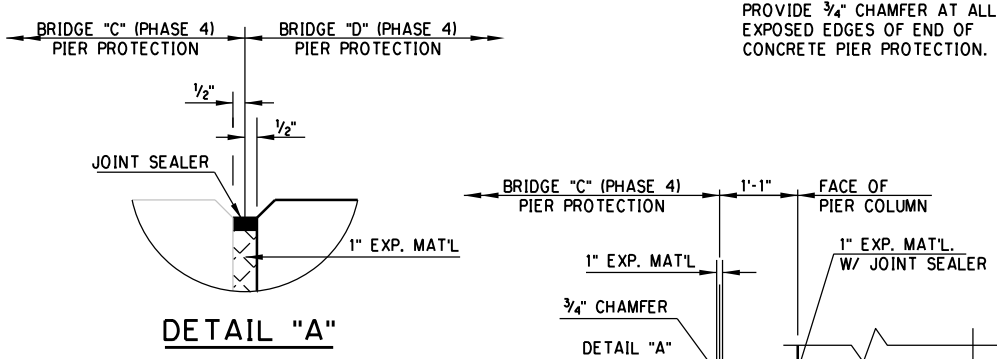

DETAIL "A"

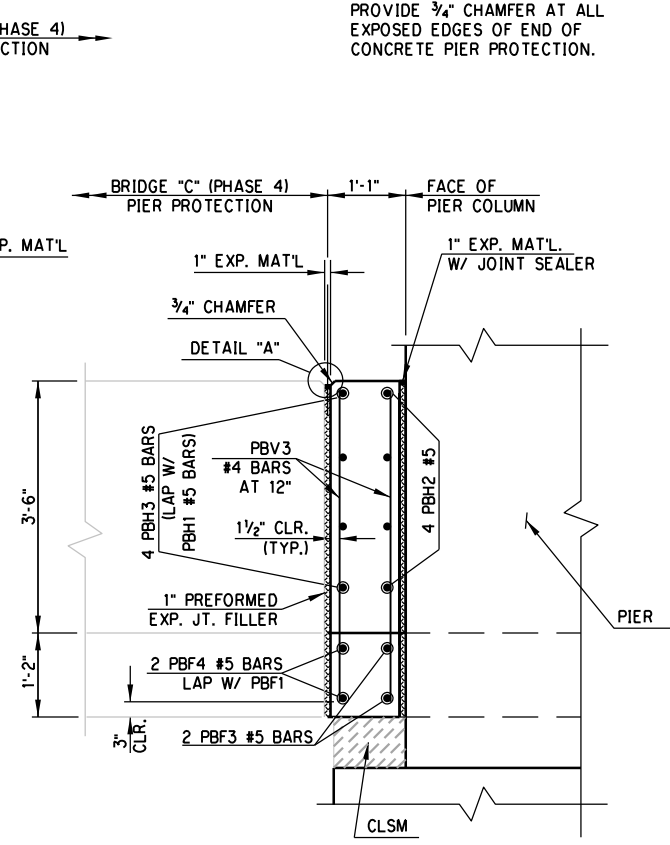

SECTION D-D
AT NORTH END

PROVIDE 3/4" CHAMFER AT ALL EXPOSED EDGES OF END OF CONCRETE PIER PROTECTION.

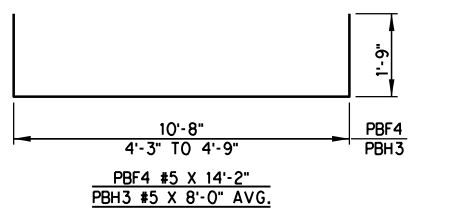
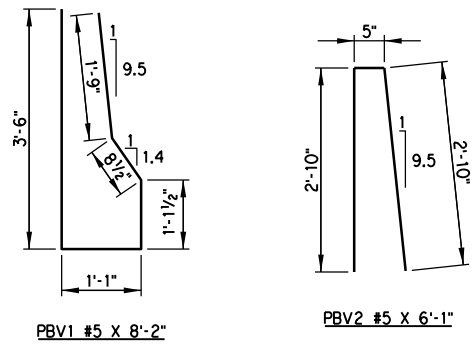

BENT BAR DIMENSIONS ARE OUT TO OUT

BAR LIST						
EPOXY COATED						
MARK	NO.	SIZE	FORM	SPACING	LENGTH	LENGTH VARIATION
PBC1	8	#4	STR.	AS SHOWN	11'-11"	--
PBC2	38	#4	STR.	12" C/C	3'-2"	--
PBC3	4	#4	STR.	AS SHOWN	10'-10"	--
PBF1	20	#5	STR.	AS SHOWN	54'-5"	--
PBF2	84	#5	STR.	AS SHOWN	3'-7"	--
PBF3	76	#5	STR.	12" C/C	10'-6"	--
PBF4	4	#5	BNT.	AS SHOWN	14'-0"	--
PBV1	16	#5	STR.	AS SHOWN	54'-5"	--
PBV2	8	#5	STR.	AS SHOWN	4'-6" AVG.	4'-3" TO 4'-9"
PBV3	8	#5	BNT.	AS SHOWN	8'-0" AVG.	7'-9" TO 8'-3"
PBV4	146	#5	BNT.	AS SHOWN	8'-2"	--
PBV5	3	#5	BNT.	AS SHOWN	8'-4"	--

QUANTITIES		
ITEM	UNIT	TOTAL
CLASS A CONCRETE	C.Y.	31.10
EPOXY COATED REINFORCING STEEL	LB.	5,740.00

NOTE: COST OF SAWCUTTING, REMOVAL OF EXISTING PIER PROTECTION & MEDIAN BARRIER, PAVEMENT REMOVAL, EXCAVATION, GRANULAR BACKFILL, APPROXIMATELY 53 C.Y. OF CLSM BACKFILL, JOINT FILLER AND JOINT SEALER ARE INCLUDED IN OTHER ITEMS OF WORK.

PHASE 4
BRIDGE "D"

OKLAHOMA COUNTY
1-240 OVER 1-35

PIER PROTECTION DETAILS
PIER NO. 2
(SHEET 2 OF 2)

STATE JOB NO. 09032(08) SHEET NO. B113

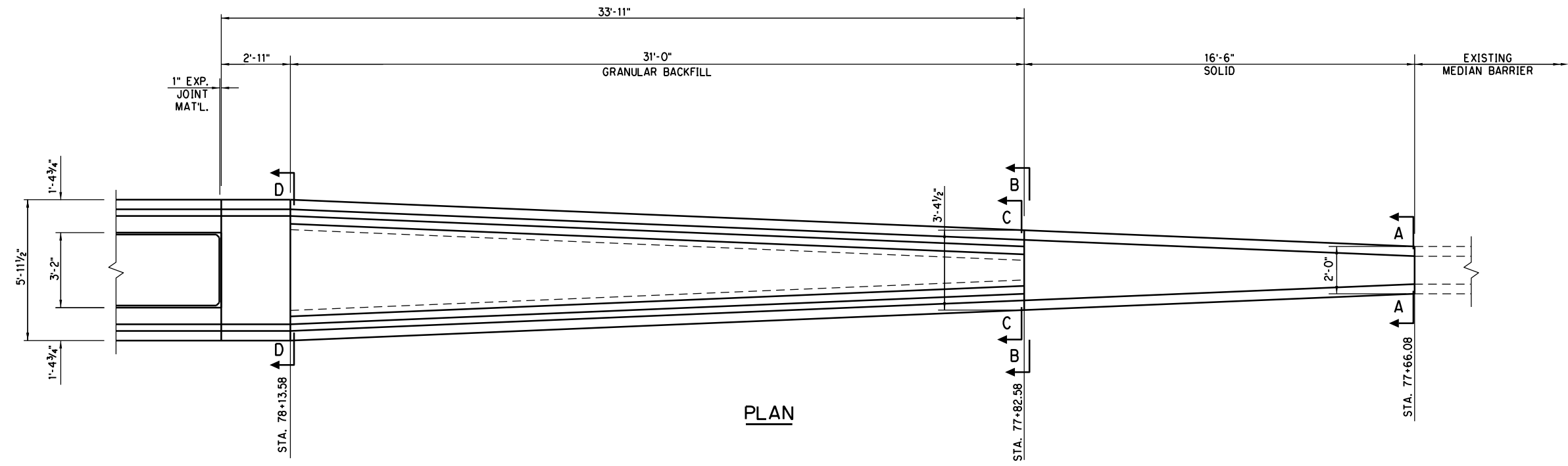

PLAN

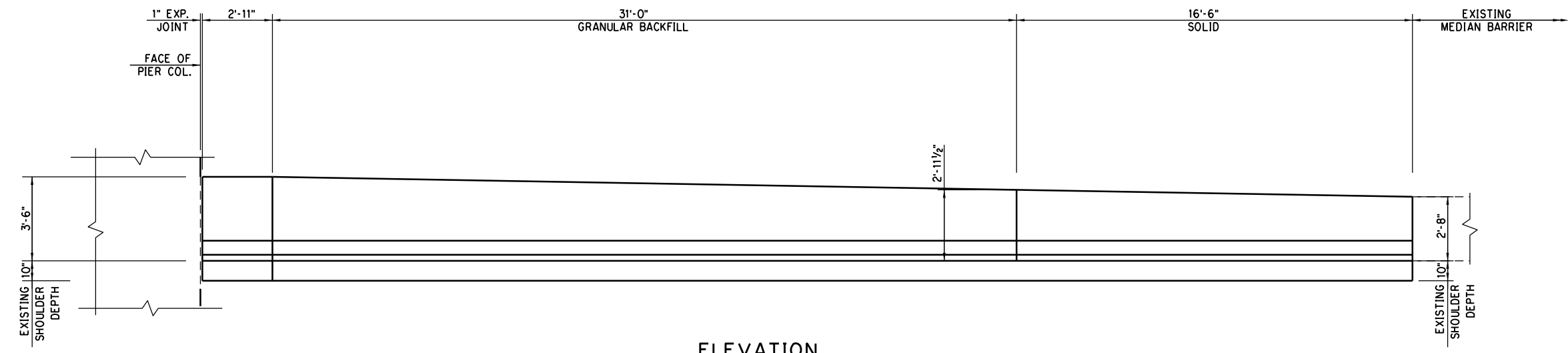

ELEVATION

3/1/2024 2:25:56 PM H:\PROJECTS\2789_CrossRoads_Phase 4\Bridges\Drawings\Ph4 Bridges\Bridges\0903208 P4 Bridge D Pier Protection Transition.dgn

DESIGN			PHASE 4	OKLAHOMA COUNTY
DRAWN			BRIDGE "D"	1-240 OVER 1-35
CHECKED			MEDIAN BARRIER TRANSITION DETAILS (SHEET 1 OF 2)	
APPROVED				
SQUAD	POE			
			STATE JOB NO. 09032(08)	SHEET NO. B114

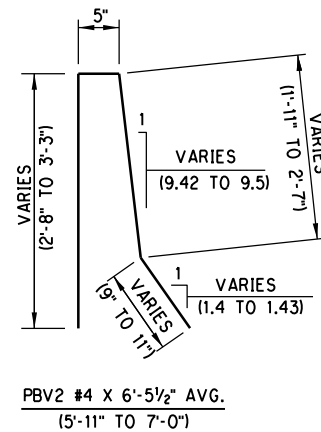
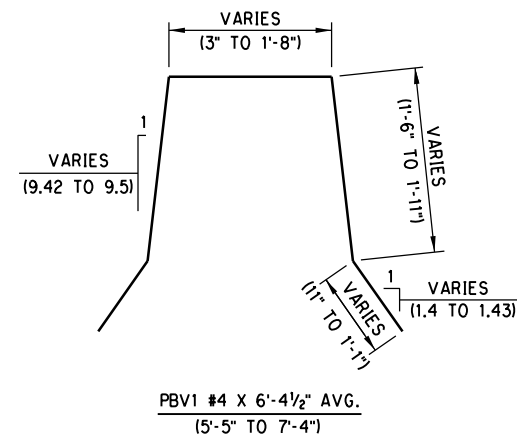
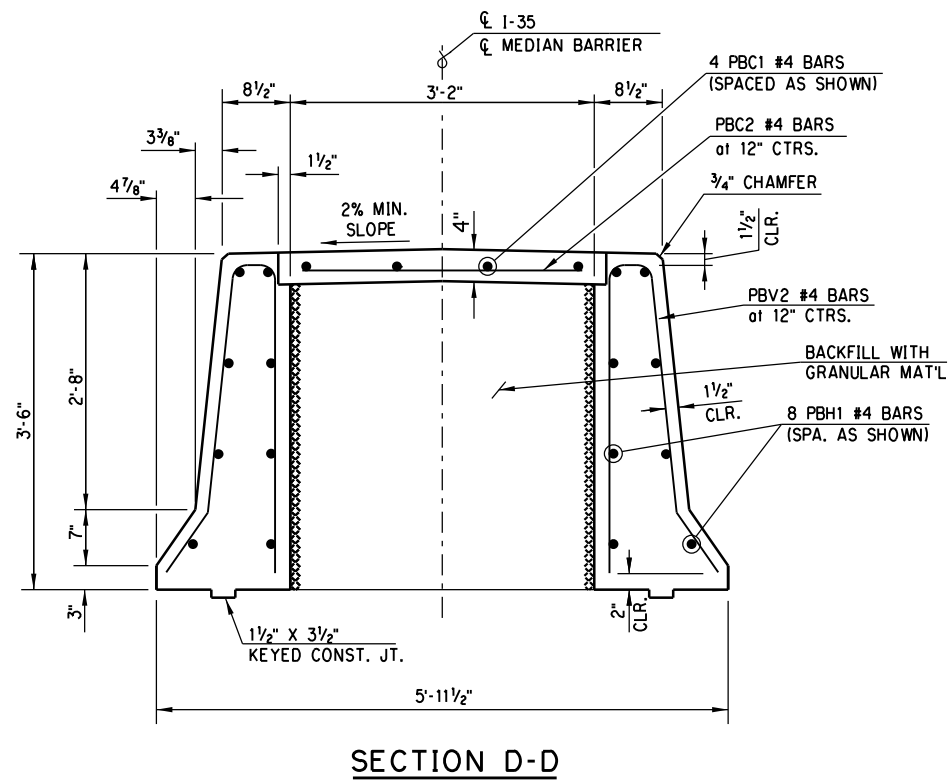
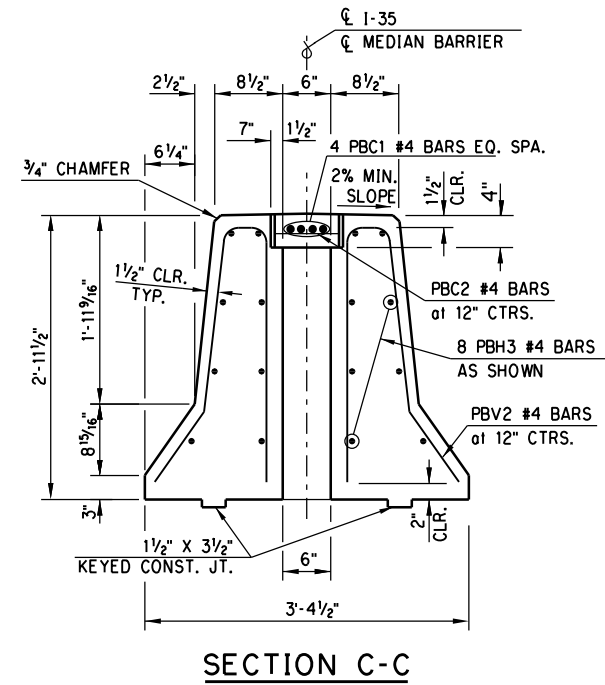
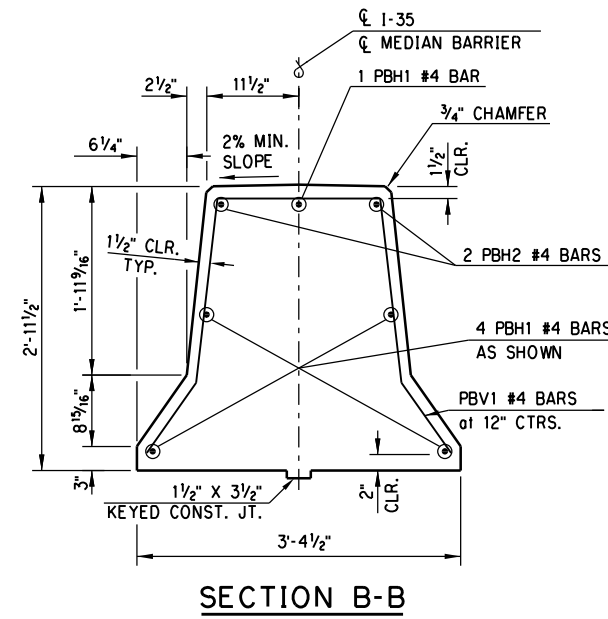
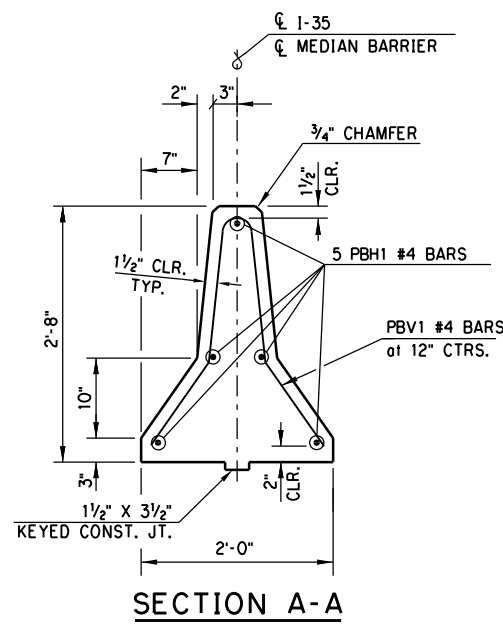

BAR LIST (EPOXY COATED)						
MARK	SIZE	NO.	FORM	SPACING	LENGTH	LENGTH VARIANCE
PBC1	#4	4	STR.	AS SHOWN	30'-8"	--
PBC2	#4	32	STR.	12" C/C	2'-11"	--
PBH1	#4	5	STR.	AS SHOWN	16'-2"	--
PBH2	#4	2	STR.	AS SHOWN	8'-3"	--
PBH3	#4	16	STR.	AS SHOWN	30'-8"	--
PBV1	#4	17	BNT.	12" C/C	6' 4-1/2" AVG.	5'-5" TO 7'-4"
PBV2	#4	32	BNT.	12" C/C	6' 5-1/2" AVG.	5'-11" TO 7'-0"

QUANTITIES		
ITEM	UNIT	TOTAL
CLASS A CONCRETE	C.Y.	10.80
EPOXY COATED REINFORCING STEEL	LB.	750.00

3/1/2024 2:25:57 PM H:\PROJECTS\2789_CrossRoads_Phase 4\Bridges\Drawings\Ph4 Bridges\Bridges\Bridges D Pler Protection Transition.dgn

BENT BAR DIMENSIONS ARE OUT TO OUT

DESIGN	
DRAWN	
CHECKED	
APPROVED	
SQUAD	POE

PHASE 4 BRIDGE "D" OKLAHOMA COUNTY 1-240 OVER 1-35

**MEDIAN BARRIER
TRANSITION DETAILS**
(SHEET 2 OF 2)

STATE JOB NO. 09032(08) SHEET NO. B115

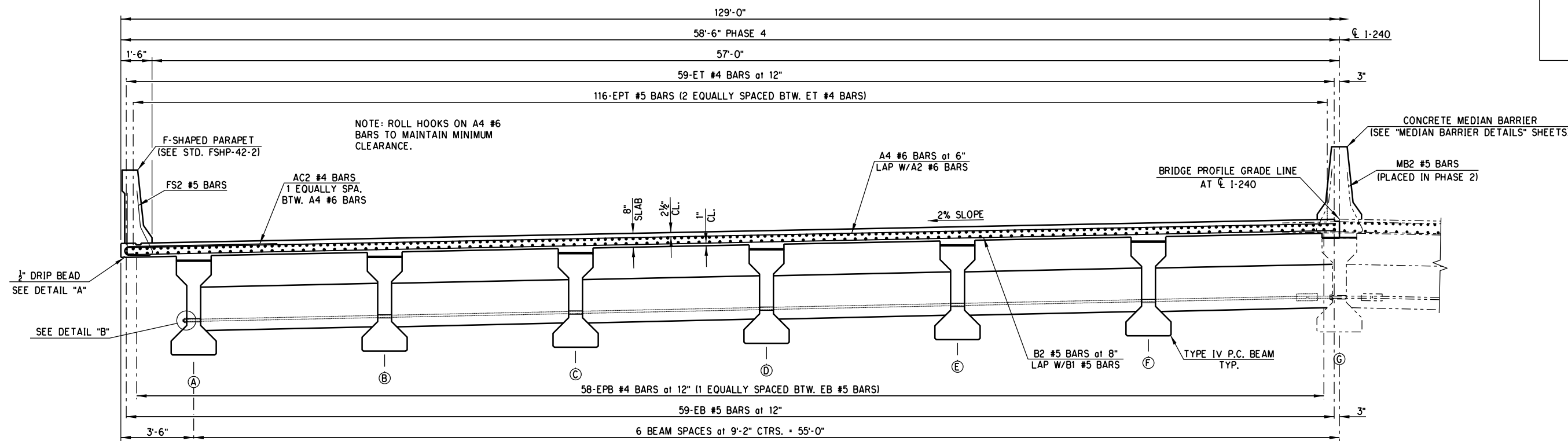

HALF SECTION AT PIER DIAPHRAGM - PHASE 4

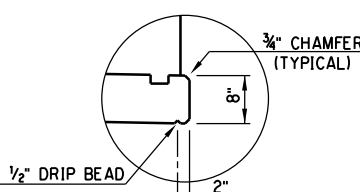
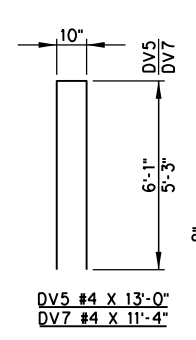
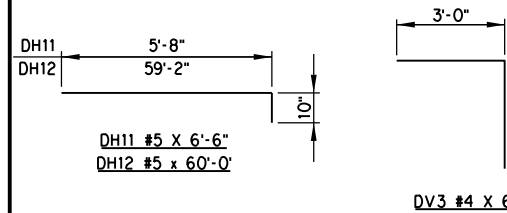

DETAIL "A"

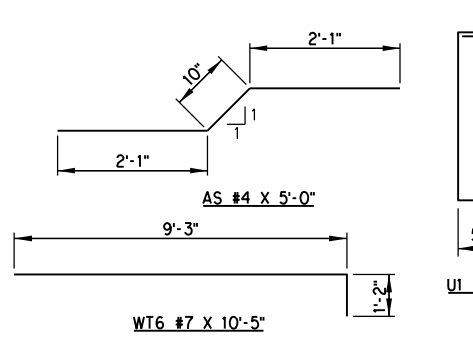
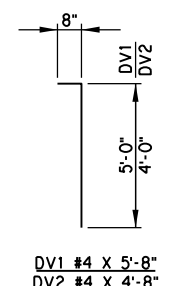
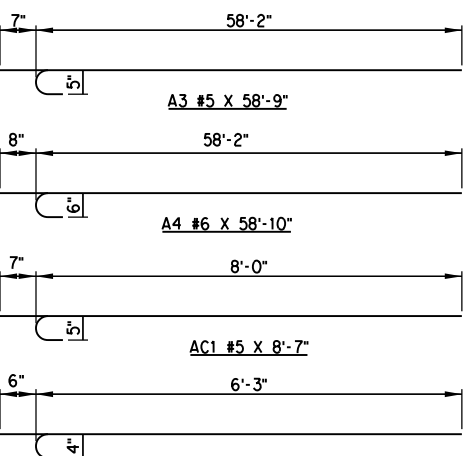

BAR BENDS
(BENT BAR DIMENSIONS ARE OUT TO OUT)

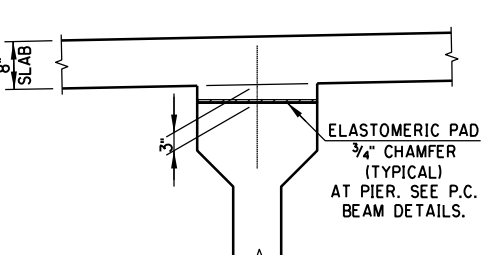

BEAM HAUNCH DETAIL

NOTE: PLAN QUANTITIES FOR CLASS AA CONCRETE INCLUDE BEAM HAUNCHES. THE HAUNCH HEIGHTS SHOWN IS THE THEORETICAL HAUNCH HEIGHT AT THE CENTERLINE BEARING ONLY, MEASURED FROM THE BOTTOM OF THE DECK SLAB TO THE TOP OF THE BEAM, AND VARIES ACROSS THE SPAN. DETERMINE THE ACTUAL HAUNCH HEIGHT (ACCOUNTING FOR BEAM CAMBER, DEAD LOAD DEFLECTION AND ROADWAY GRADE) AFTER ERECTION OF THE BEAMS AND SUBMIT TO THE ENGINEER FOR APPROVAL. THE ENGINEER WILL NOT MEASURE DIFFERENCES BETWEEN THE THEORETICAL AND THE ACTUAL HAUNCH HEIGHTS FOR PAYMENT.

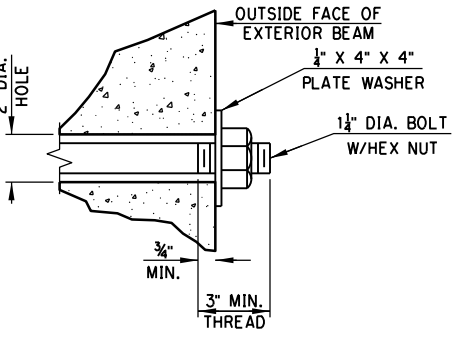

DETAIL "B"

NOTE: PROVIDE STRUCTURAL STEEL FOR DIAPHRAGM BOLTS AND PLATE WASHERS IN ACCORDANCE WITH AASHTO M270 (ASTM A709), GRADE 50W (WEATHERING STEEL, CHARPY V-NOTCH TESTING NOT REQUIRED). THE CONTRACTOR MAY SUBSTITUTE A #10 REINFORCING BAR IN ACCORDANCE WITH AASHTO M31, GRADE 60, AND THREADED AT THE ENDS AS SHOWN FOR THE DIAPHRAGM BOLT AT NO ADDITIONAL COST TO THE DEPARTMENT. PROVIDE HEX NUTS IN ACCORDANCE WITH AASHTO M291 (ASTM A563). PAINT EXPOSED DIAPHRAGM BOLT, PLATE WASHER AND HEX NUT WITH TWO (2) COATS OF ZINC-RICH PAINT (6 MIL MINIMUM THICKNESS) AFTER ASSEMBLY. INCLUDE ALL COST OF DIAPHRAGM BOLT, PLATE WASHER AND HEX NUT IN THE CONTRACT UNIT PRICE FOR STRUCTURAL STEEL.

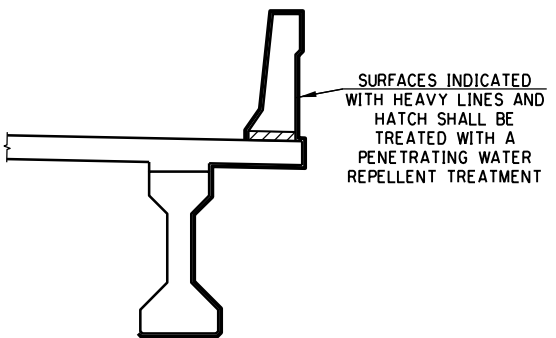

WATER REPELLENT SURFACE TREATMENT

NOTE: FOR WATER REPELLENT TREATMENT DETAILS OF CONCRETE MEDIAN BARRIER, SEE "MEDIAN BARRIER DETAILS" SHEET 2 OF 2.

SUPERSTRUCTURE QUANTITIES		
ITEM	UNIT	TOTAL
PRESTRESSED CONC. BEAMS (TYPE IV)	L.F.	1,912.00
SAW CUT GROOVING	S.Y.	1,994.00
CONCRETE PARAPET	L.F.	320.50
42" F-SHAPED PARAPET	L.F.	320.50
STRUCTURAL STEEL	LB.	2,390.00
WEATHERING STEEL FIXED BRG. ASSEMBLY	EA.	12.00
STAINLESS STEEL EXPANSION BRG. ASSEMBLY	EA.	36.00
ELASTOMERIC BEARING PADS	EA.	36.00
CLASS AA CONCRETE	C.Y.	568.00
EPOXY COATED REINFORCING STEEL	LB.	127.17
WATER REPELLENT (VISUALLY INSPECTED)	S.Y.	1,018.00
SEALER CRACK PREPARATION	L.F.	342.00
SEALER RESIN	GAL.	4.00

FOR SLAB LAYOUT, SEE SHEET 2 OF 4.
FOR LONGITUDINAL SECTION, SEE "LONGITUDINAL SECTION AND DIAPHRAGM DETAILS" SHEET.

DESIGN		PHASE 4	OKLAHOMA COUNTY
DRAWN		BRIDGE "D"	1-240 OVER 1-35
CHECKED		SUPERSTRUCTURE DETAILS	
APPROVED		(SHEET 1 OF 4)	
SQUAD	POE	STATE JOB NO. 09032108	SHEET NO. 1116

3/1/2024 2:26:00 PM H:\PROJECTS\2789_CrossRoads_Phase 4 Bridge\Drawings\Ph4 Bridges\Bridges\Bridges 0903208 P4 Bridge D SUPER.dgn

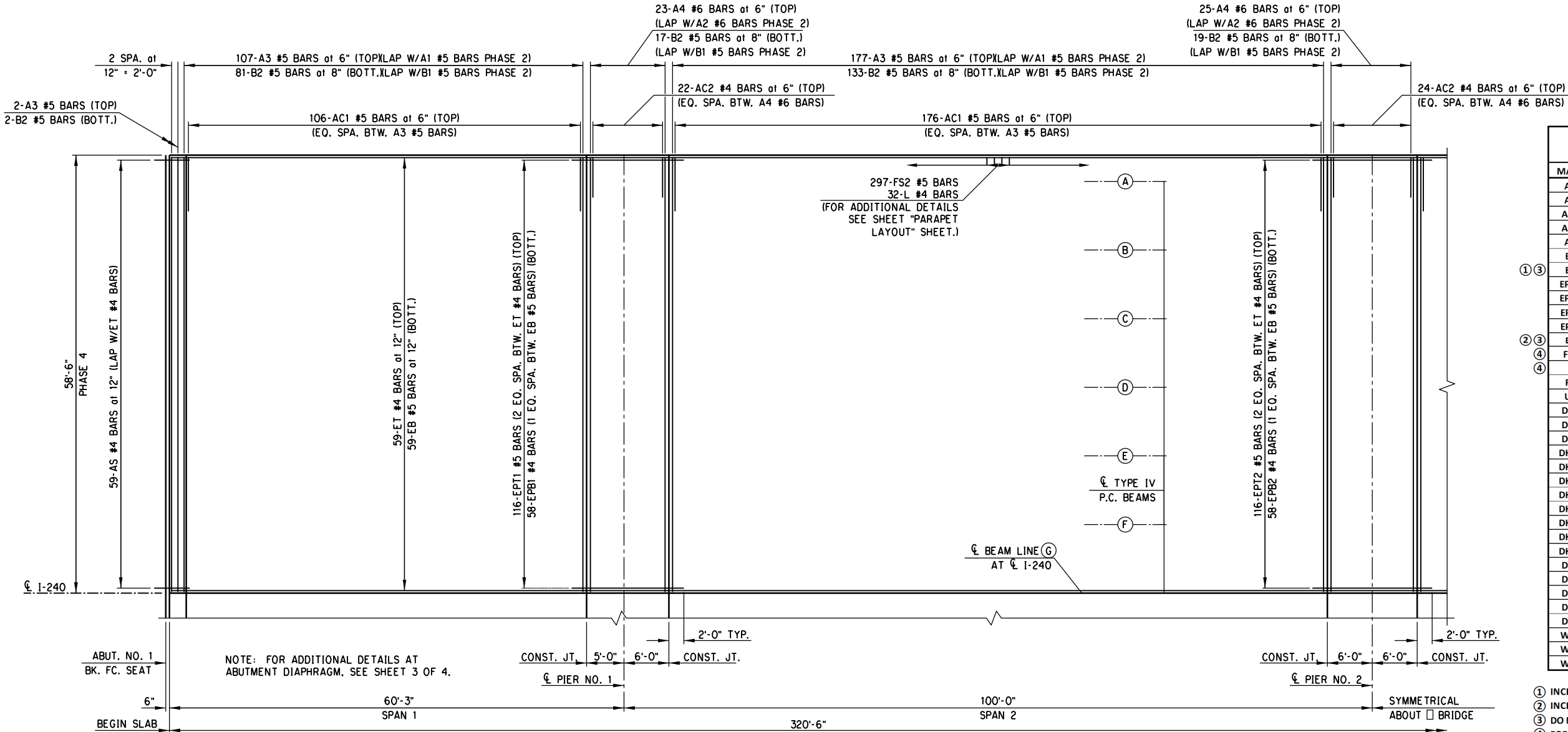

BAR LIST (EPOXY COATED)					
MARK	NO.	SIZE	FORM	SPACING	LENGTH
A3	572	#5	BNT.	6" C/C	58'-9"
A4	71	#6	BNT.	6" C/C	58'-10"
AC1	564	#5	BNT.	6" C/C	8'-7"
AC2	68	#4	BNT.	6" C/C	6'-9"
AS	118	#4	BNT.	12" C/C	5'-0"
B2	485	#5	STR.	8" C/C	58'-2"
EB	59	#5	STR.	12" C/C	335'-10"
EPB1	116	#4	STR.	12" C/C	15'-0"
EPB2	58	#4	STR.	12" C/C	16'-0"
EPT1	232	#5	STR.	12" C/C	15'-0"
EPT2	116	#5	STR.	12" C/C	16'-0"
ET	59	#4	STR.	12" C/C	330'-4"
FS2	297	#5	BNT.	12" C/C	7'-4"
L	32	#4	BNT.	AS SHOWN	1'-3"
F1	360	#4	STR.	AS SHOWN	8'-7"
U1	600	#4	BNT.	AS SHOWN	4'-9"
DH7	2	#5	STR.	AS SHOWN	3'-9"
DH8	4	#5	STR.	AS SHOWN	4'-3"
DH9	2	#5	STR.	AS SHOWN	3'-11"
DH10	2	#5	STR.	AS SHOWN	3'-6"
DH11	8	#5	BNT.	AS SHOWN	6'-6"
DH12	10	#5	BNT.	AS SHOWN	60'-0"
DH13	12	#5	STR.	AS SHOWN	7'-2"
DH14	24	#5	STR.	AS SHOWN	8'-2"
DH15	12	#5	STR.	AS SHOWN	7'-6"
DH16	12	#5	STR.	AS SHOWN	6'-8"
DH17	32	#5	STR.	AS SHOWN	4'-4"
DV1	116	#4	BNT.	AS SHOWN	5'-8"
DV2	118	#4	BNT.	12" C/C	4'-8"
DV3	118	#4	BNT.	12" C/C	6'-0"
DV6	4	#4	STR.	AS SHOWN	5'-6"
DV7	6	#4	BNT.	AS SHOWN	11'-10"
WT5	18	#4	STR.	AS SHOWN	5'-9"
WT6	18	#7	BNT.	AS SHOWN	10'-5"
WT7	6	#7	BNT.	AS SHOWN	19'-6"

- ① INCLUDES 6 - 2'-7" MIN. LAPS
- ② INCLUDES 6 - 1'-8" MIN. LAPS
- ③ DO NO LAP WITHIN 10 FEET OF CENTERLINE OF PIER
- ④ FOR BAR BEND, SEE STD. FSHP-42-2

SLAB REINFORCING LAYOUT

CONSTRUCTION JOINTS (SEAL WITH HIGH MOLECULAR WEIGHT METHACRYLATE)

NOTE: SEAL TRANSVERSE CONSTRUCTION JOINTS BETWEEN INSIDE FACE OF PARAPET AND INSIDE FACE OF MEDIAN BARRIER.

NOTE: CONCRETE PARAPET AND MEDIAN BARRIER NOT SHOWN IN LAYOUT FOR CLARITY. FOR DETAILS OF PARAPET SEE STD. FSHP-42-2. AND FOR DETAILS OF MEDIAN BARRIER SEE SHT. BD23 AND BD24.

NOTE: PHASE 2 SLAB REINFORCING AND APPROACH SLAB NOT SHOWN FOR CLARITY.

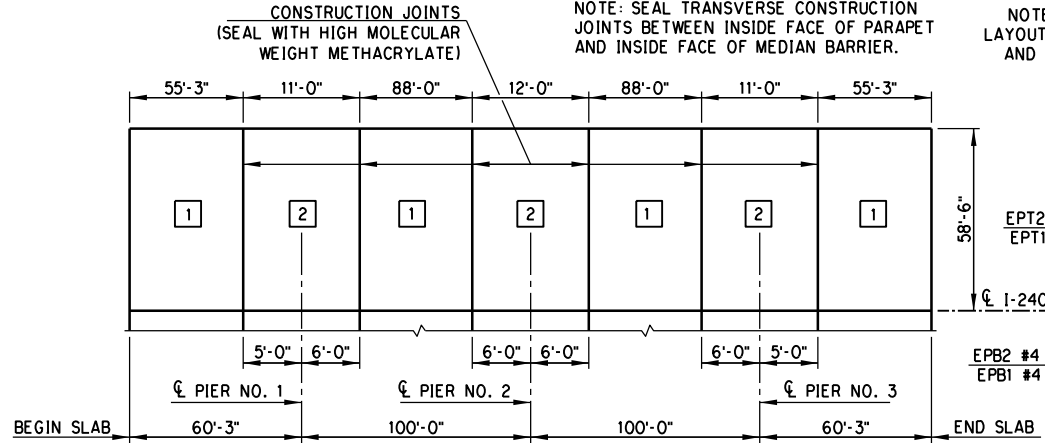

SLAB POURING SEQUENCE

DECK SLAB POURING SEQUENCE DIAGRAM NOTE

THE DECK SLAB IS DIVIDED INTO SECTIONS BETWEEN CONSTRUCTION JOINTS AS SHOWN. THE CONCRETE SHALL BE POURED IN EACH SECTION OF THE DECK SLAB IN THE NUMERICAL SEQUENCE INDICATED. SECTIONS OF THE DECK SLAB WITH THE SAME NUMBER MAY BE POURED IN ANY ORDER. UNDER NO CIRCUMSTANCES WILL SECTION IN SEQUENCE 2 BE POURED BEFORE THE ADJACENT SECTIONS HAVE BEEN IN PLACE FOR AT LEAST 48 HOURS.

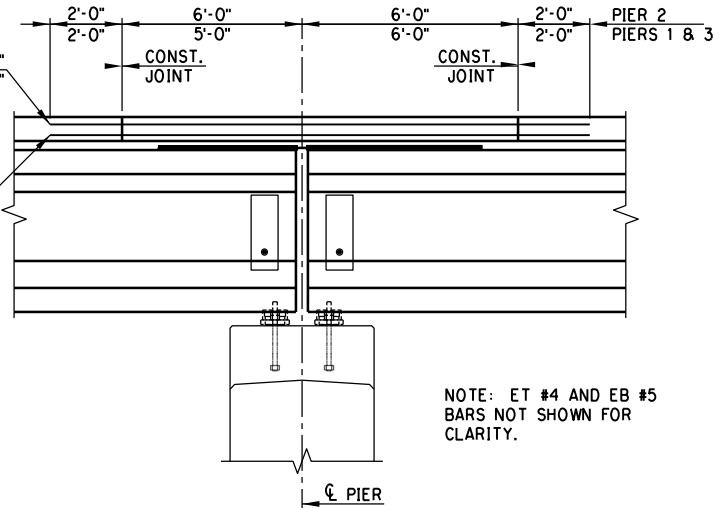

DETAIL OF LONGITUDINAL BARS OVER PIERS

NOTE: ET #4 AND EB #5 BARS NOT SHOWN FOR CLARITY.

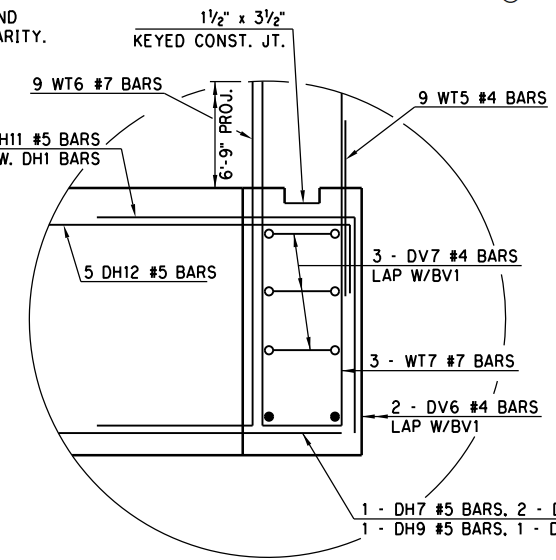

DETAIL AT EDGE

DESIGN	
DRAWN	
CHECKED	
APPROVED	
SQUAD	POE

PHASE 4 BRIDGE "D" OKLAHOMA COUNTY 1-240 OVER I-35

SUPERSTRUCTURE DETAILS
(SHEET 2 OF 4)

3/1/2024 2:26:02 PM H:\PROJECTS\2789_Crossroads_Phase 4\Bridges\Drawings\Ph4 Bridges\Bridges\0903208 P4 Bridge D SUPER.dgn

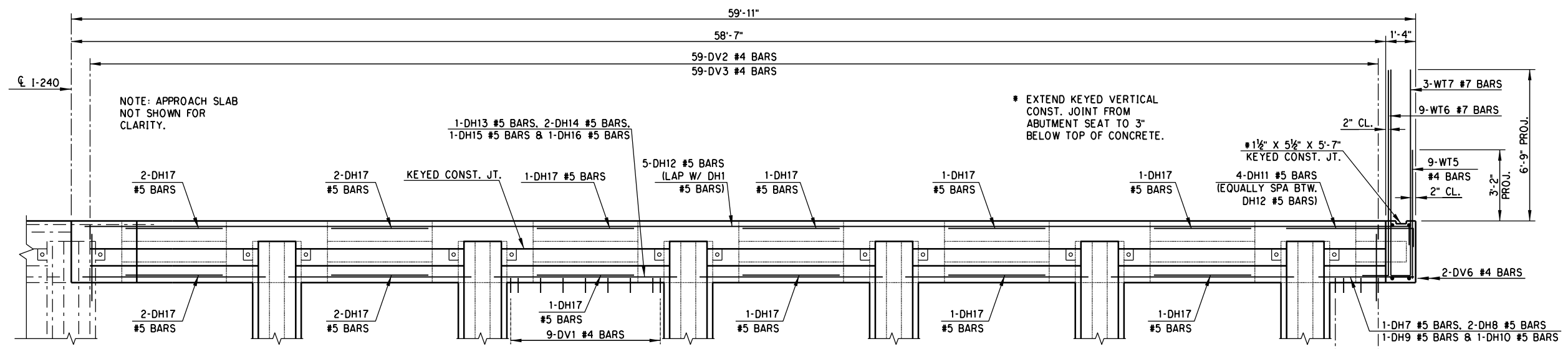

PLAN

END DIAPHRAGM AT ABUTMENT NO. 1 SHOWN.
ABUTMENT NO. 2 IS OPPOSITE HAND.

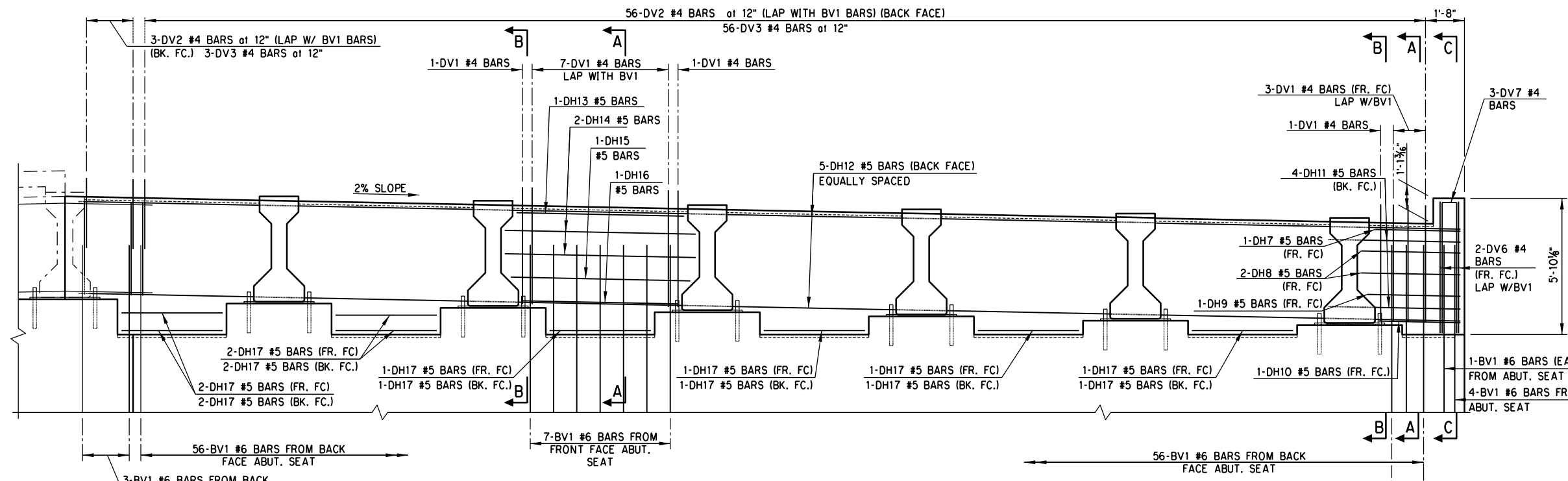

**TYPICAL FRONT FACE
REINFORCING BETWEEN BEAMS**

ELEVATION

END DIAPHRAGM AT ABUTMENT NO. 1 SHOWN.
ABUTMENT NO. 2 IS OPPOSITE HAND.

NOTE: FOR BAR BENDS AND BAR LIST, AND SECTIONS A-A, B-B & C-C, SEE SHEET 4 OF 4

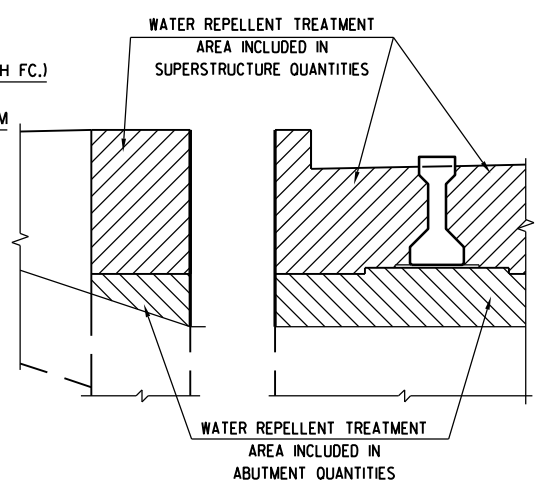

**SIDE ELEVATION
WATER REPELLENT TREATMENT DETAILS**

TREAT SURFACES INDICATED BY HEAVY LINE OR HATCH WITH WATER REPELLENT (VISUALLY INSPECTED)

3/1/2024 2:26:03 PM H:\PROJECTS\2789_CrossRoads_Phase 4\Bridges\Drawings\Ph4 Bridges\Bridges\0903208 P4 Bridge D SUPER.dgn

DESIGN	
DRAWN	
CHECKED	
APPROVED	
SQUAD	POE

PHASE 4
BRIDGE "D" OKLAHOMA COUNTY
1-240 OVER 1-35

**SUPERSTRUCTURE DETAILS
(SHEET 3 OF 4)**

STATE JOB NO. 09032(08) SHEET NO. B118

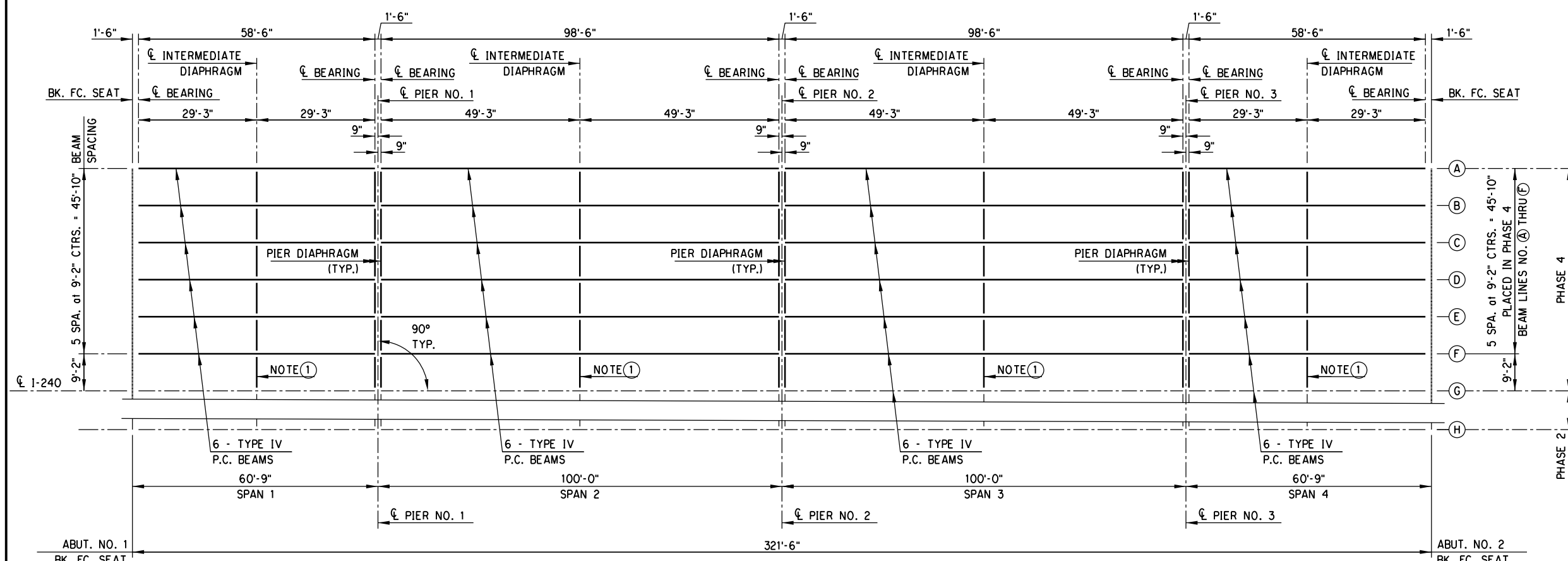

① NOTE: INTERMEDIATE DIAPHRAGMS BETWEEN BEAM LINES (F) AND (G) SHALL BE CONSTRUCTED AFTER THE DECK SLAB HAS BEEN PLACED IN PHASE 4.

PLAN

DO NOT PLACE THE CONCRETE FOR THE DECK SLAB OR APPLY OTHER MASSIVE LOADS TO THE BEAMS OR DIAPHRAGMS UNTIL THE CONCRETE IN THE DIAPHRAGMS HAS BEEN IN PLACE A MINIMUM OF 10 DAYS OR AT THE DISCRETION OF THE ENGINEER. THIS TIME MAY BE SHORTENED IF THE CONCRETE HAS ATTAINED 80% OF THE SPECIFIED CONCRETE STRENGTH.

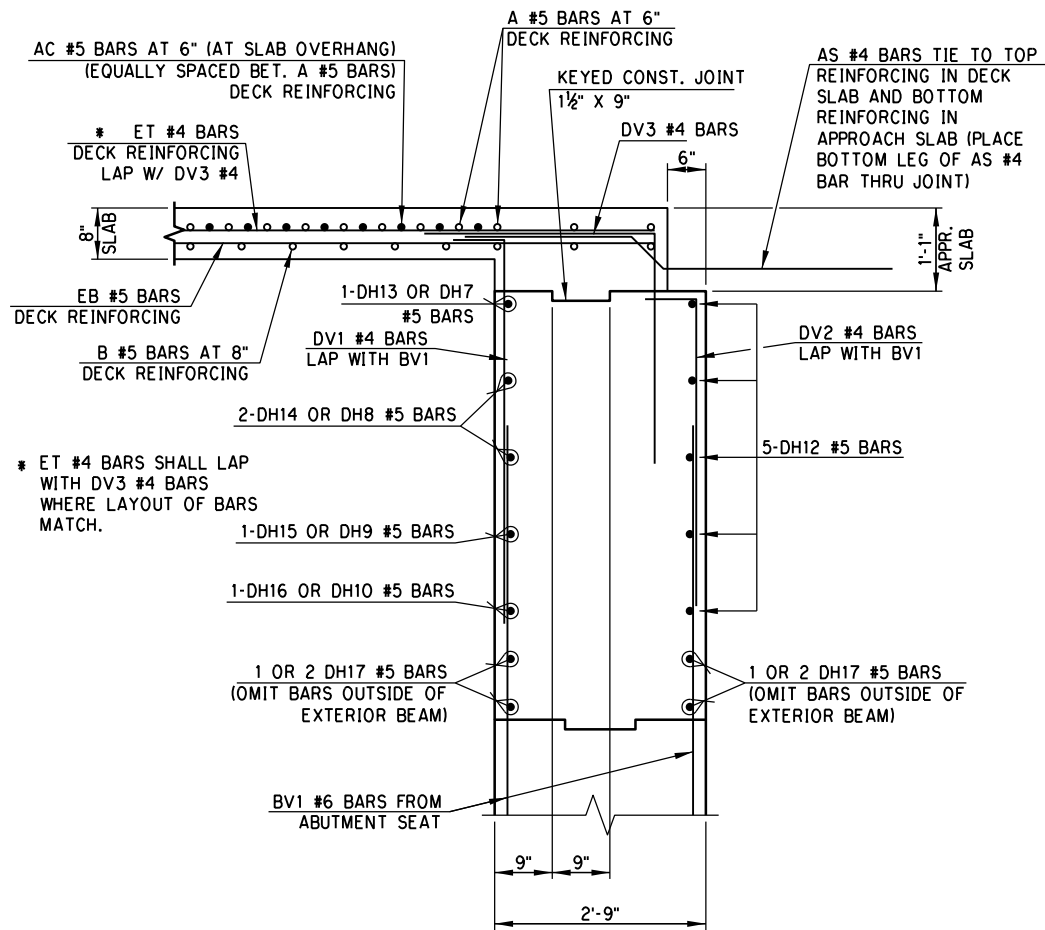

SECTION A-A

(SLAB REINFORCEMENT SHOWN FOR INFORMATIONAL PURPOSES)

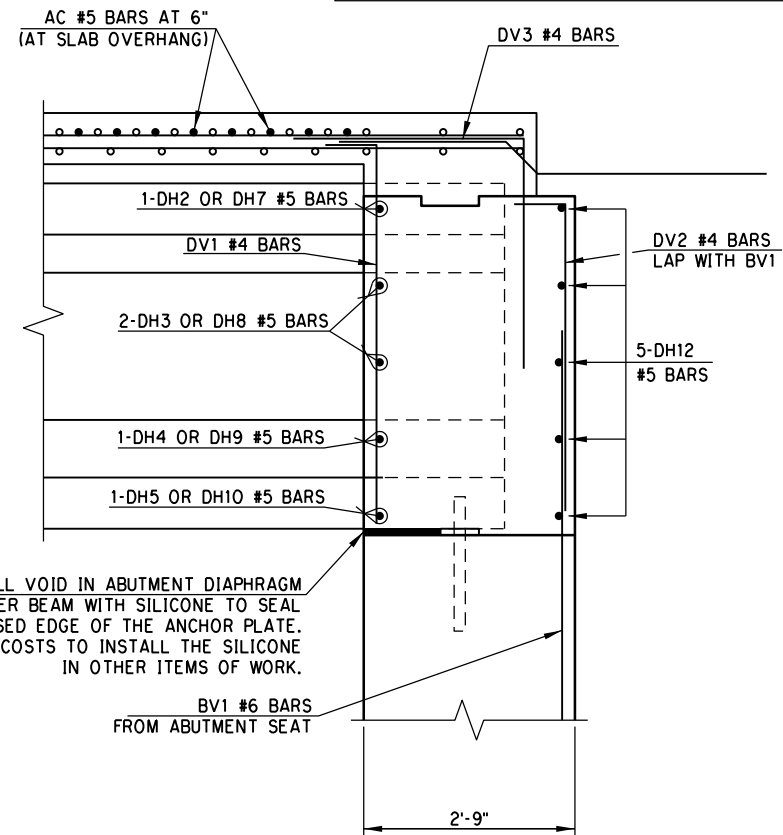

SECTION B-B

(SLAB REINFORCEMENT SHOWN FOR INFORMATIONAL PURPOSES)

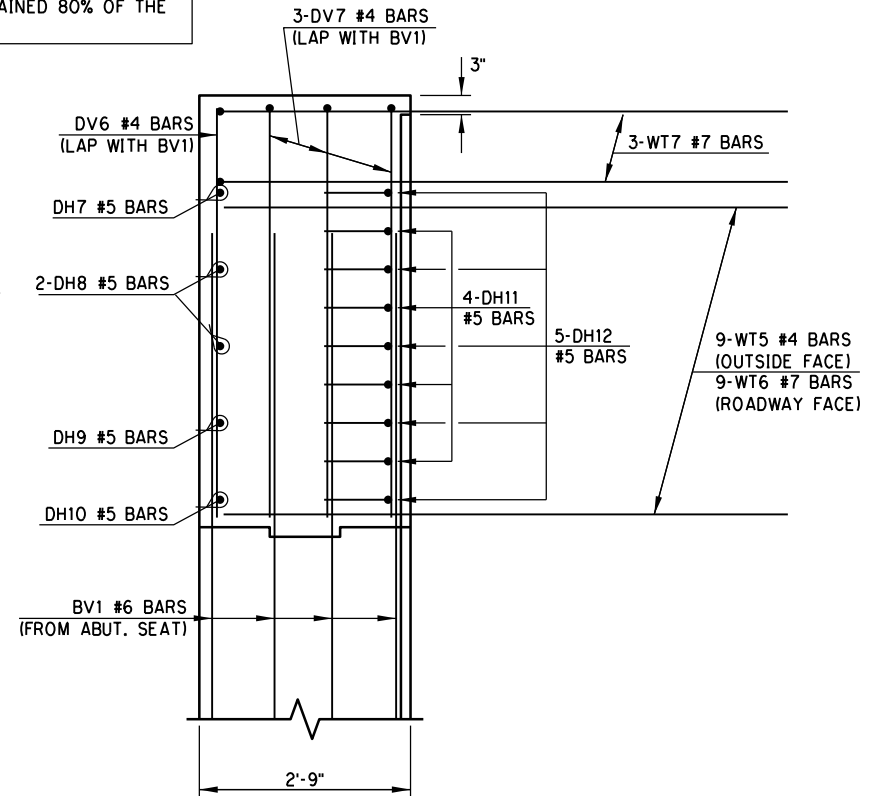

SECTION C-C

DESIGN	
DRAWN	
CHECKED	
APPROVED	
SQUAD	POE

PHASE 4 BRIDGE "D" OKLAHOMA COUNTY 1-240 OVER 1-35

SUPERSTRUCTURE DETAILS
(SHEET 4 OF 4)

STATE JOB NO. 09032108 SHEET NO. B119

3/1/2024 2:26:04 PM H:\PROJECTS\2789_CrossRoads_Phase 4\Bridges\Drawings\Ph4 Bridges\Bridges\0903208 P4 Bridge D SUPER.dgn

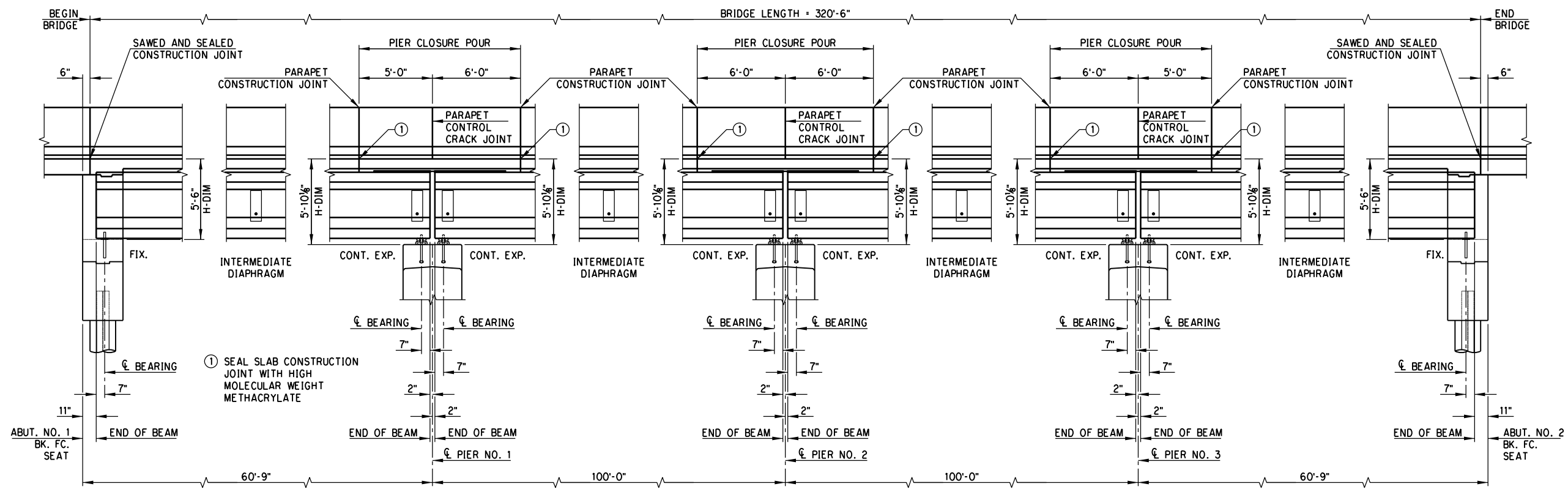

LONGITUDINAL SECTION

NOTE: H-DIMENSION IS FROM TOP OF DECK SLAB TO BOTTOM OF BEARING ASSEMBLY at ϕ BEARING.

DO NOT PLACE THE CONCRETE FOR THE DECK SLAB OR APPLY OTHER MASSIVE LOADS TO THE BEAMS OR DIAPHRAGMS UNTIL THE CONCRETE IN THE DIAPHRAGMS HAS BEEN IN PLACE A MINIMUM OF 10 DAYS OR at THE DISCRETION OF THE ENGINEER. THIS TIME MAY BE SHORTENED IF THE CONCRETE HAS ATTAINED 80% OF THE SPECIFIED COMPRESSIVE STRENGTH.

NOTE: DECK SHALL NOT BE PLACED ON BEAMS YOUNGER THAN 28 DAYS OLD.

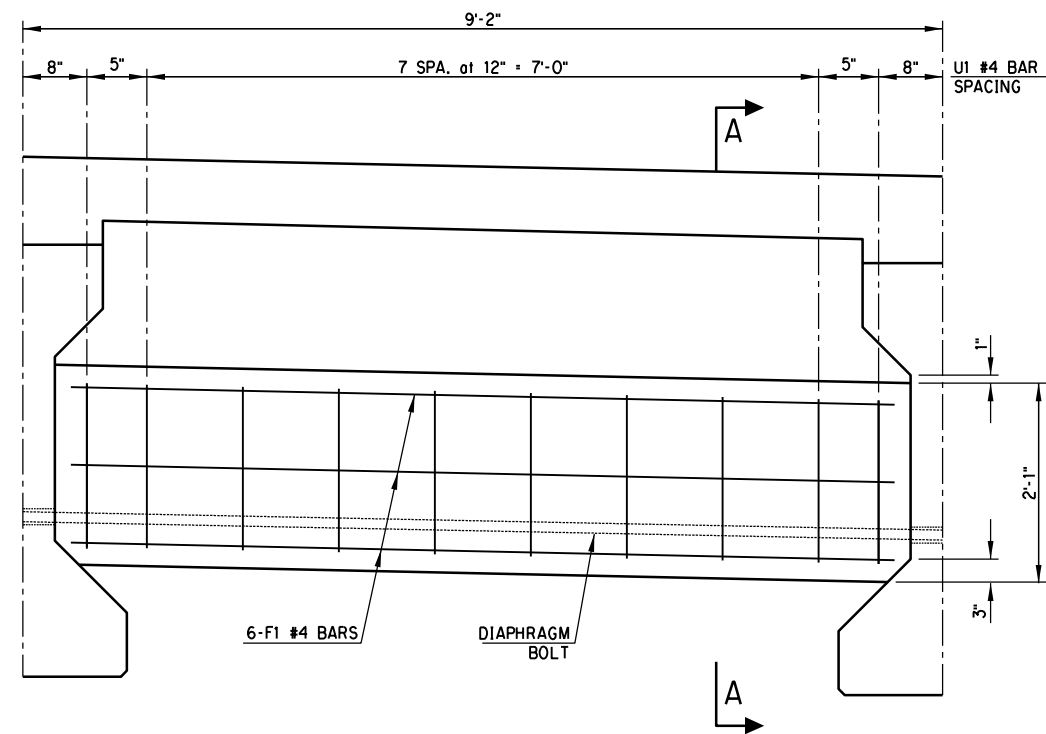

INTERMEDIATE AND PIER DIAPHRAGM

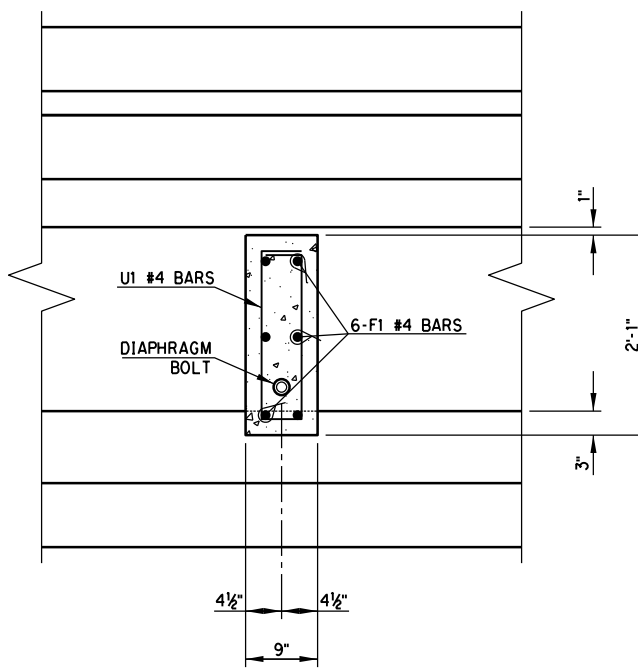

INTERMEDIATE DIAPHRAGM

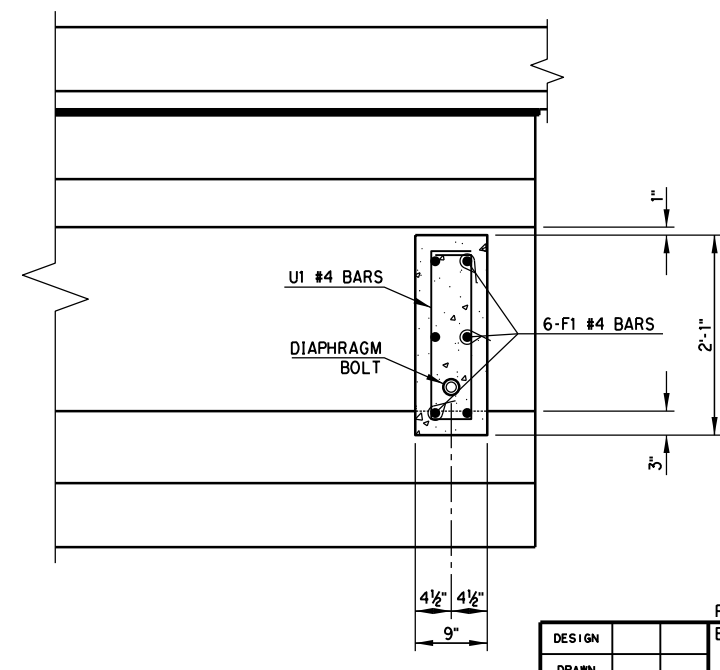

PIER DIAPHRAGM

SECTION A-A

DESIGN	
DRAWN	
CHECKED	
APPROVED	
SQUAD	POE

PHASE 4
BRIDGE "D"
OKLAHOMA COUNTY
1-240 OVER 1-35

LONGITUDINAL SECTION AND DIAPHRAGM DETAILS

STATE JOB NO. 090321081 SHEET NO. B120

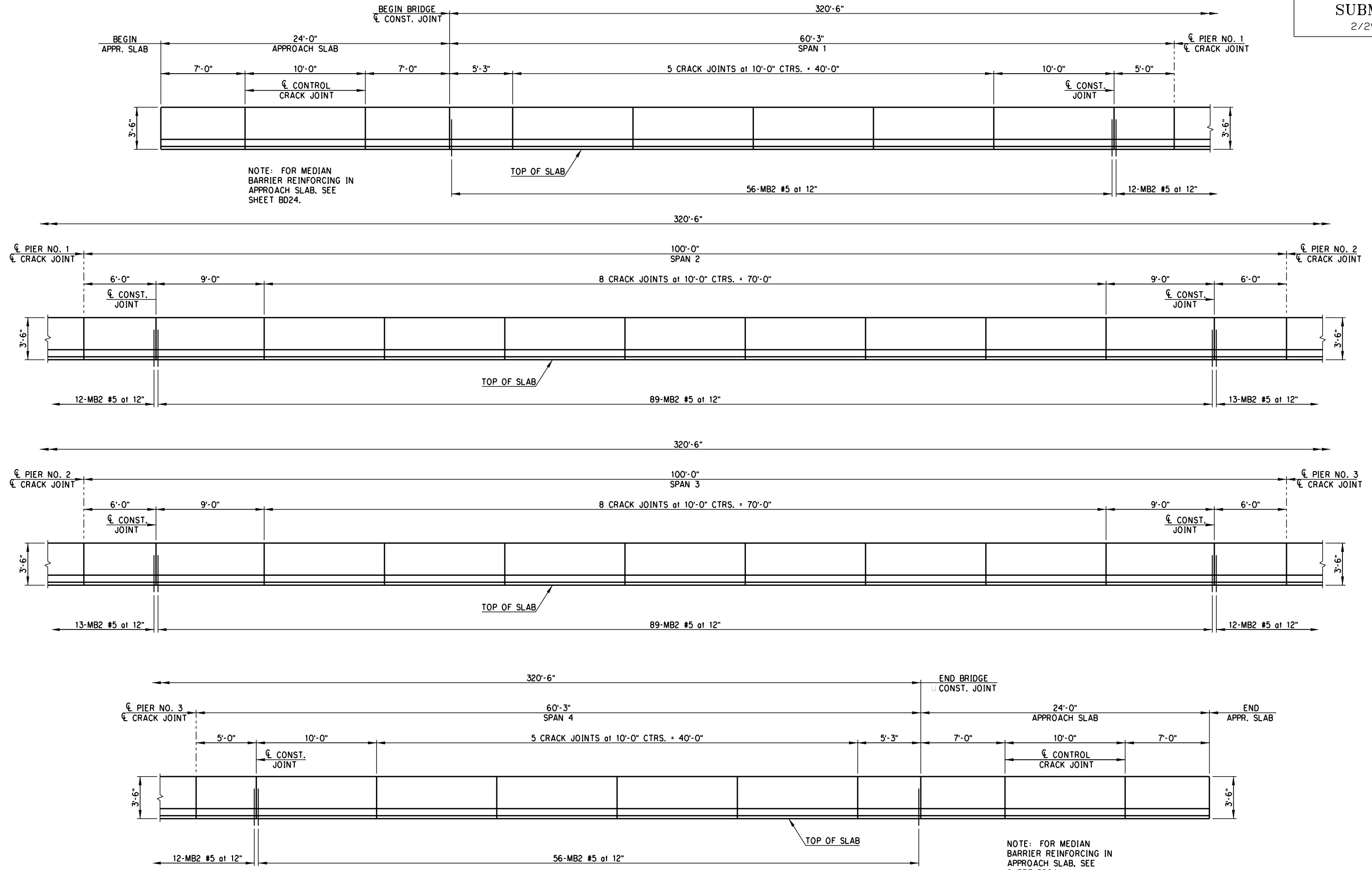

MEDIAN BARRIER ELEVATION

NOTE: FOR MEDIAN BARRIER REINFORCING IN APPROACH SLAB, SEE SHEET BD24.

3/1/2024 2:26:09 PM H:\PROJECTS\2789_CrossRoads_Phase 4\Bridges\Drawings\Ph4 Bridges\Bridges\Bridges\0903208 P4 Bridge D Parapet & Median Barrier Layout.dgn

DESIGN	
DRAWN	
CHECKED	
APPROVED	
SQUAD	POE

PHASE 4
BRIDGE "D"
OKLAHOMA COUNTY
1-240 OVER 1-35
MEDIAN BARRIER DETAILS
(SHEET 1 OF 2)
STATE JOB NO. 09032108 SHEET NO. B122

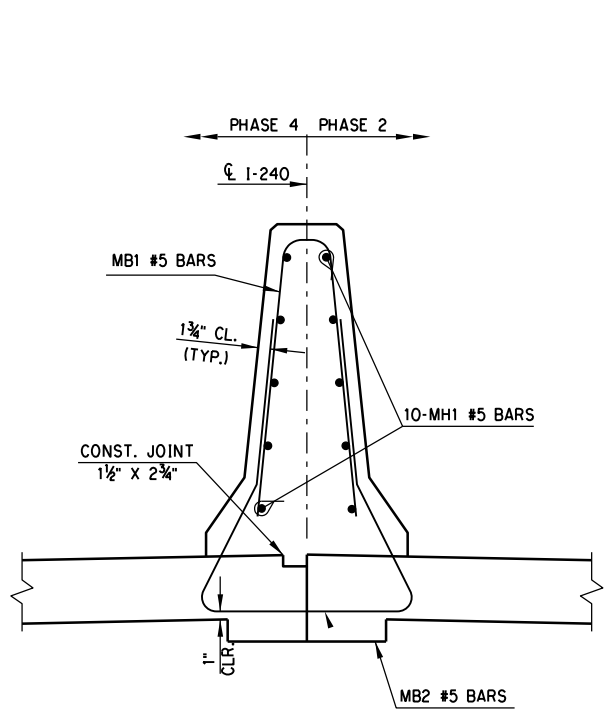

SECTION THRU MEDIAN BARRIER AT DECK SLAB

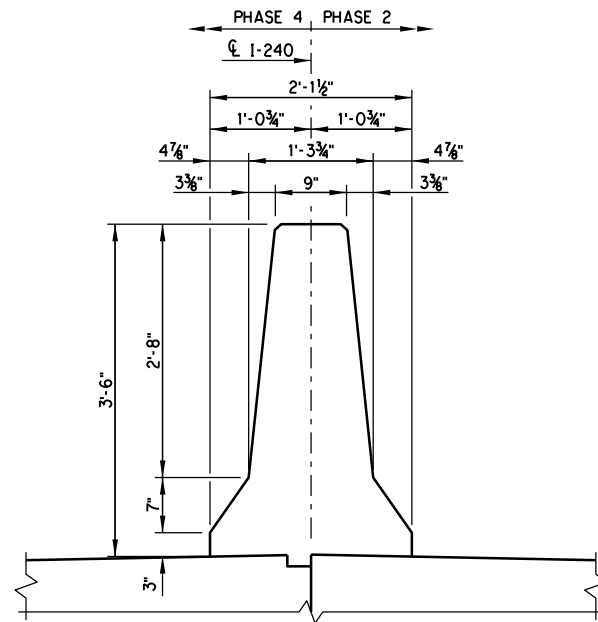

TYPICAL SECTION

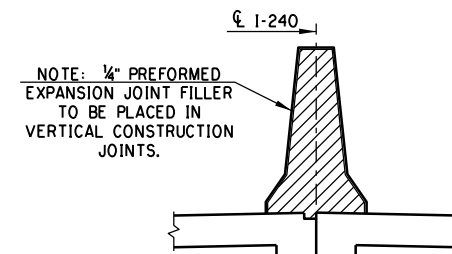

CONSTRUCTION JOINT

(FOR LOCATION OF CONSTRUCTION JOINTS, SEE "MEDIAN BARRIER DETAILS" SHEET 1 OF 2)

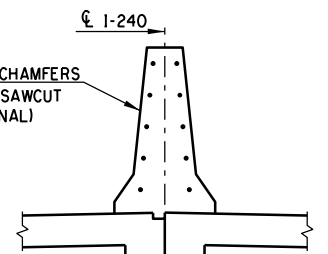

CONTROL CRACK JOINT

NOTE: ALL BARS SHALL BE CONTINUOUS THRU CONTROL CRACK JOINT.

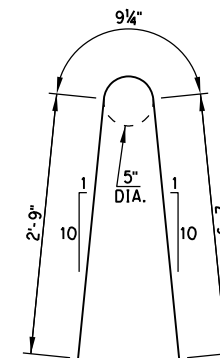

MB1 #5 X 6'-3 3/4"

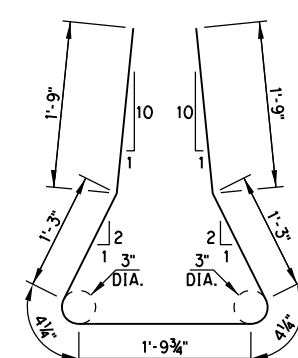

MB2 #5 X 8'-6 1/2"

BAR BENDS

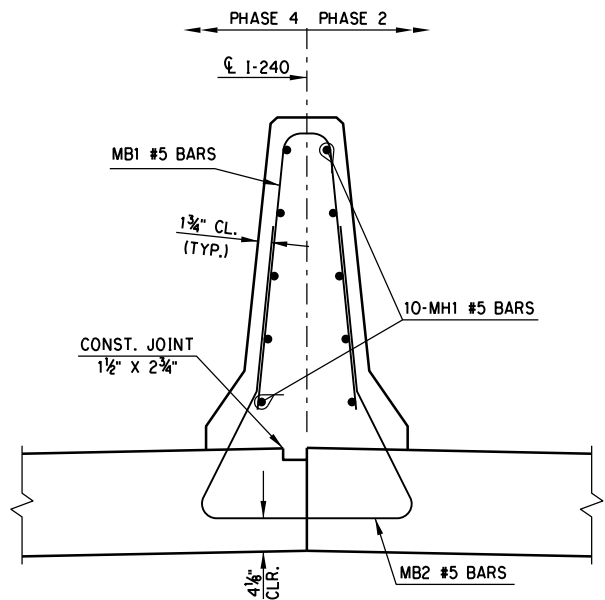

SECTION THRU MEDIAN BARRIER AT APPROACH SLAB

NOTE: DECK AND APPROACH SLAB REINFORCING NOT SHOWN FOR CLARITY.

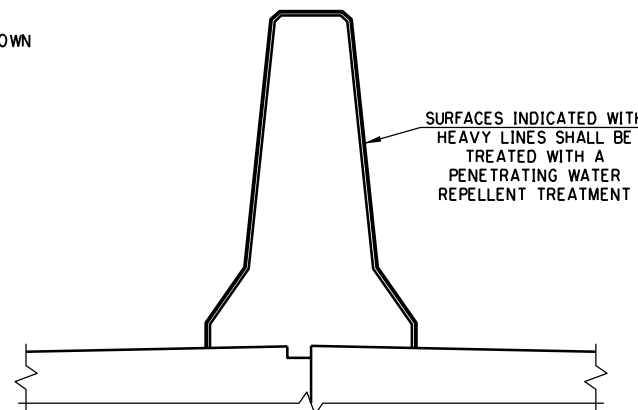

WATER REPELLENT SURFACE TREATMENT

SURFACES INDICATED WITH HEAVY LINES SHALL BE TREATED WITH A PENETRATING WATER REPELLENT TREATMENT

CONCRETE MEDIAN BARRIER

CONSTRUCT THE MEDIAN BARRIER TO MEET THE REQUIREMENTS OF THE STANDARD SPECIFICATIONS FOR HIGHWAY CONSTRUCTION (ENGLISH), AS WELL AS THE FOLLOWING REQUIREMENTS:

CLASS AA CONCRETE:

CLASS AA CONCRETE SHALL BE USED IN THE MEDIAN BARRIER. ALL COSTS OF CONCRETE TO BE INCLUDED IN THE PRICE BID PER LINEAR FOOT OF "CONCRETE PARAPET".

REINFORCING STEEL:

ALL REINFORCING STEEL USED IN THE MEDIAN BARRIER SHALL BE EPOXY COATED. PLACE AND TIE ALL MB2 BARS BEFORE CONCRETE IS PLACED IN THE DECK SLAB OR APPROACH SLAB, AS APPLICABLE. THE WEIGHT OF THE MB2 BARS WILL BE MEASURED AND PAID FOR AS "EPOXY COATED REINFORCING STEEL". ALL OTHER REINFORCING STEEL IN THE MEDIAN BARRIER SHALL BE INCLUDED IN THE UNIT PRICE BID PER LINEAR FOOT OF "CONCRETE PARAPET".

CONSTRUCTION JOINTS:

PLACE A CONSTRUCTION JOINT AT EACH FIXED ABUTMENT AND AT LOCATIONS SHOWN ON SHEET B122 PLACE 1/4" THICK PREFORMED EXPANSION MATERIAL IN THE CONSTRUCTION JOINT IN ACCORDANCE WITH THE DETAILS SHOWN. DO NOT PLACE MH BARS THROUGH A CONSTRUCTION JOINT UNLESS DIRECTED TO DO SO IN THE PLANS.

CONTROL CRACK JOINTS:

PROVIDE DOUBLE 3/8" CHAMFERS OR 3/8" DEEP SAWCUT IN ACCORDANCE WITH THE DETAILS SHOWN. PLACE THE CONTROL CRACK JOINTS AT 10'-0" SPACINGS. PLACE CONTROL CRACK JOINTS AT LOCATIONS SHOWN ON SHEET B122 OR AS DIRECTED BY THE ENGINEER.

DESIGN	
DRAWN	
CHECKED	
APPROVED	
SQUAD	POE

PHASE 4
BRIDGE "D"
OKLAHOMA COUNTY
1-240 OVER 1-35

MEDIAN BARRIER DETAILS
(SHEET 2 OF 2)

STATE JOB NO. 09032(08) SHEET NO. B123

**90% PLAN
SUBMITTAL**

2/29/2024

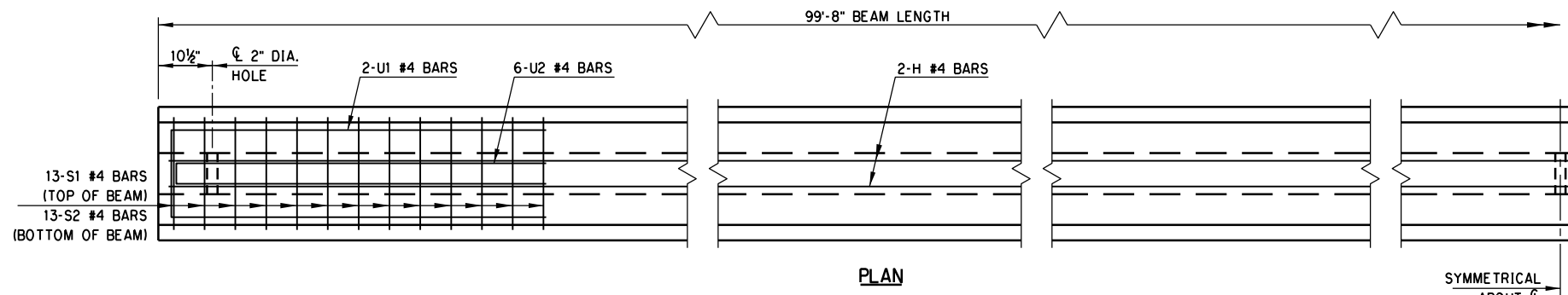

PLAN

SYMMETRICAL ABOUT CL

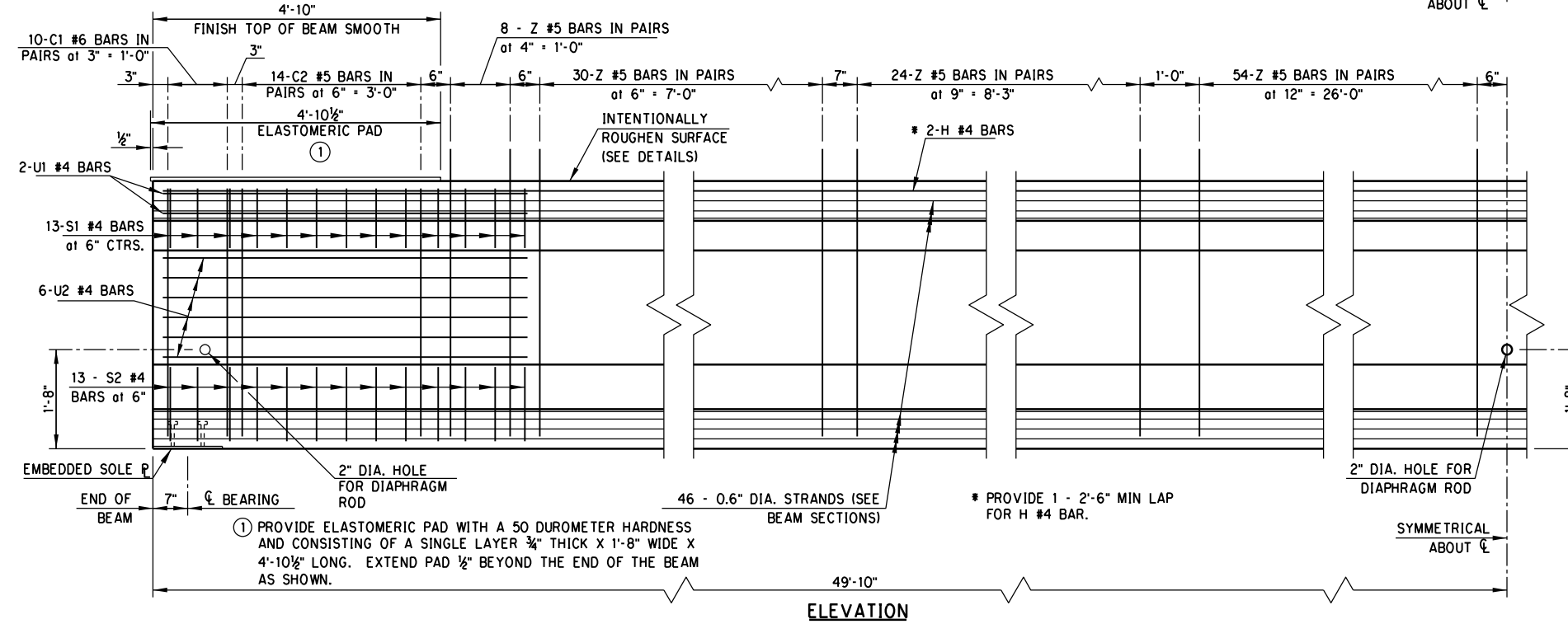

ELEVATION

SYMMETRICAL ABOUT CL

① PROVIDE ELASTOMERIC PAD WITH A 50 DUROMETER HARDNESS AND CONSISTING OF A SINGLE LAYER 3/4" THICK X 1'-8" WIDE X 4'-10 1/2" LONG. EXTEND PAD 1/2" BEYOND THE END OF THE BEAM AS SHOWN.

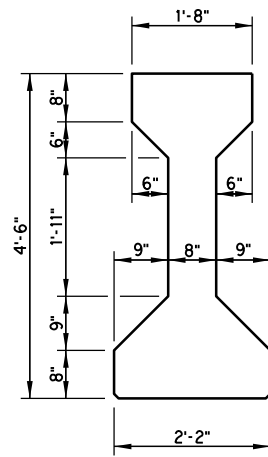

**END VIEW
(TYPE IV P.C.B.)**

PRESTRESSED CONCRETE BEAM NOTES

COMPRESSIVE STRENGTH:
PROVIDE CONCRETE WITH A COMPRESSIVE STRENGTH OF 7,000 PSI AT TRANSFER OF PRESTRESS AND 10,000 PSI AT 28 DAYS.
STRAND TYPE:
PROVIDE LOW-RELAXATION STRANDS HAVING A NOMINAL DIAMETER OF 0.6" WITH ULTIMATE TENSILE STRENGTH OF 270 KSI.

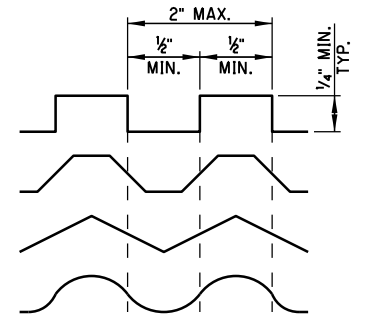

INTENTIONALLY ROUGHENED SURFACE DETAILS

(EXCLUDING END OF BEAM AS NOTED ON ELEVATION) INTENTIONALLY ROUGHEN THE ENTIRE TOP SURFACE OF P.C. BEAM TO A MINIMUM HEIGHT OF 1/4" OVER A MAXIMUM PITCH OF 2" MEASURED LONGITUDINALLY ALONG THE LENGTH OF THE BEAM. PROVIDE A CREST AND TROUGH ASSOCIATED WITH THE HEIGHT OF NOT LESS THAN 1/2". PRODUCE THE ROUGHENED SURFACE BY USING A SPECIAL TROWEL TO FORM ONE OF THE SURFACES SHOWN IN THE DETAILS. BY CLEANING THE CONCRETE SURFACE WITH A STIFF WIRE BRUSH (OR BLASTING) TO EXPOSE THE AGGREGATE TO A HEIGHT OF 1/4". OR BY USING ANOTHER APPROVED METHOD. SUBMIT THE METHOD TO BE USED FOR APPROVAL BY THE ENGINEER. REPAIR ANY DAMAGE TO REINFORCEMENT'S EPOXY COATING BEFORE PLACEMENT OF DECK CONCRETE.

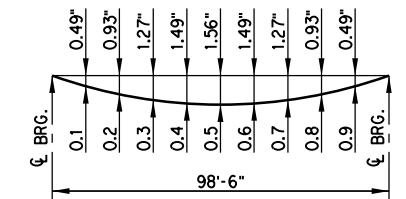

DEAD LOAD DEFLECTION DIAGRAM

NOTE: THE DEAD LOAD DEFLECTION SHOWN ABOVE AT THE TENTH POINTS ARE THE INITIAL DEFLECTIONS DUE TO DECK SLAB + DIAPHRAGMS + HAUNCH + S.I.P. STEEL DECK FORM ALLOWANCE + CONCRETE PARAPET + MEDIAN BARRIER. IT DOES NOT INCLUDE THE BEAM WEIGHT OR FUTURE WEARING SURFACE.

NOTE: FOR EMBEDDED SOLE PLATE DETAILS. SEE SHEET 2 OF 2.

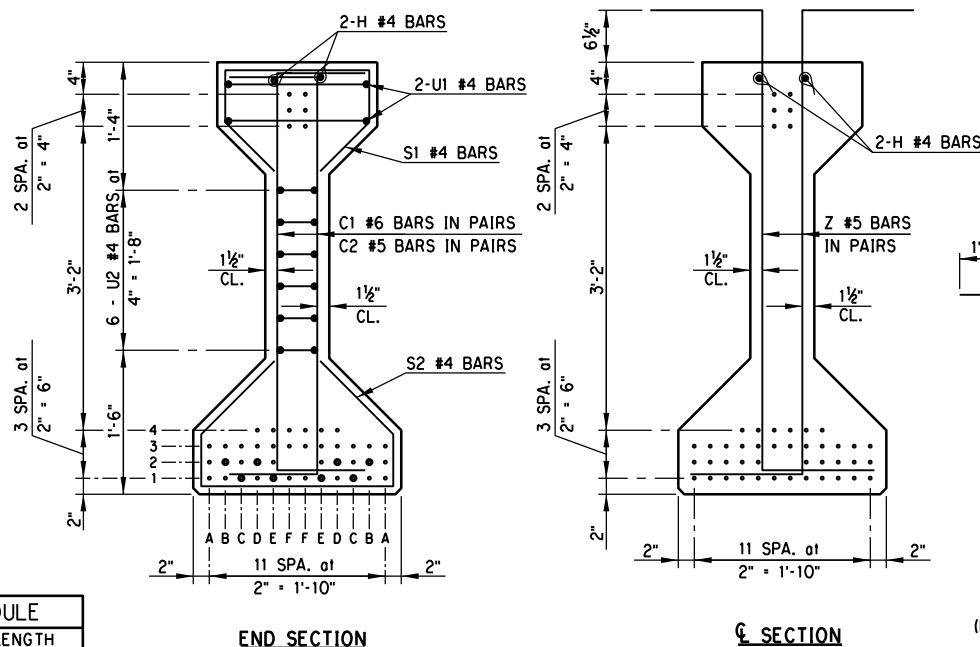

END SECTION

CL SECTION

**BEAM SECTIONS
(46 - 0.6" DIA. STRANDS)**

Z #5 X 7'-2" (EPOXY COATED)

BAR BEND DETAILS

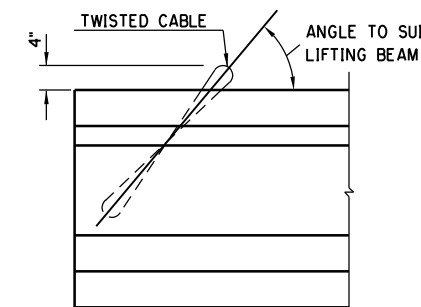
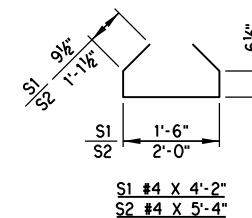

DETAIL OF LIFTING EYE

NOTE: THE USE OF DIAPHRAGM HOLE FOR LIFTING PURPOSES WILL NOT BE PERMITTED.

DEBOND SCHEDULE	
DEBOND PAIR	DEBOND LENGTH FROM END OF BEAM
C1	16'-0"
E1	8'-0"
B2 & D2	4'-0"

DESIGN	
DRAWN	
CHECKED	
APPROVED	
SQUAD	POE

PHASE 4 OKLAHOMA COUNTY
BRIDGE "D" I-240 OVER I-35

TYPE IV P.C.B. DETAILS
SPANS 2 & 3
(SHEET 1 OF 2)

STATE JOB NO. 09032108 SHEET NO. B124

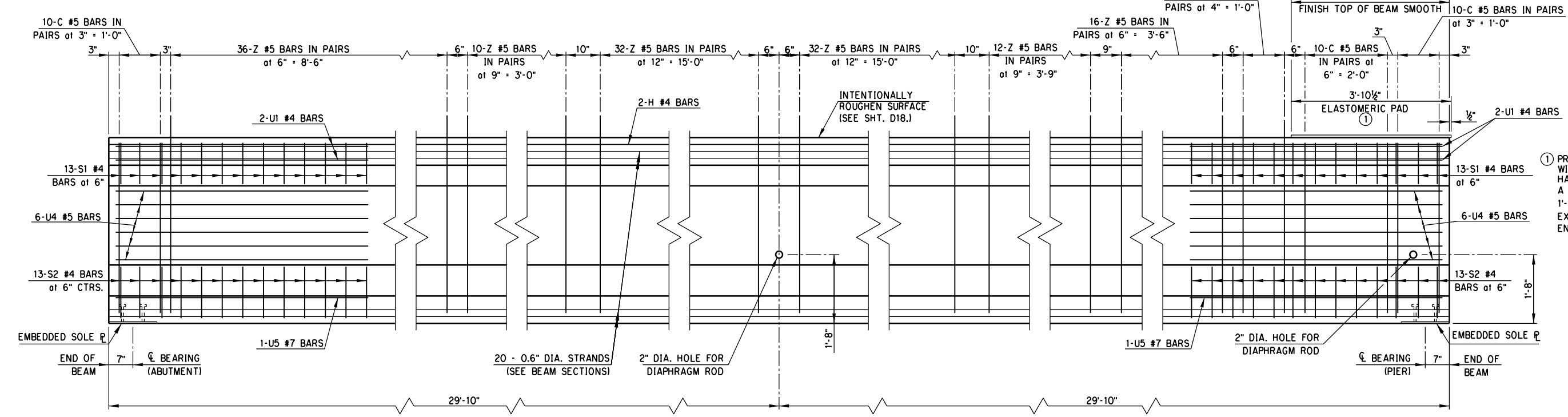
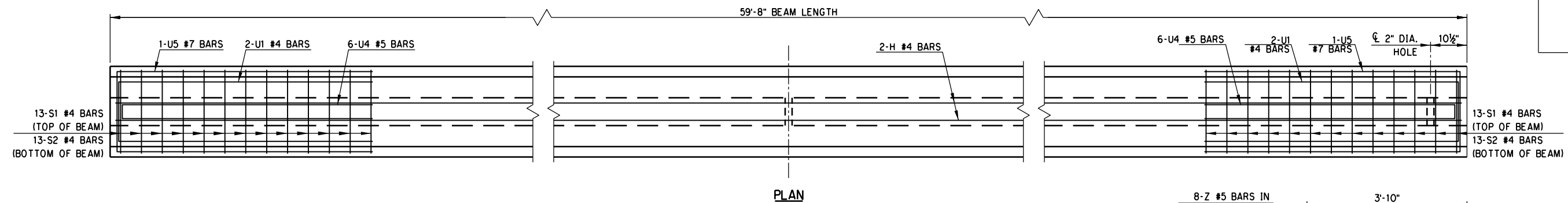

① PROVIDE ELASTOMERIC PAD WITH A 50 DUROMETER HARDNESS AND CONSISTING OF A SINGLE LAYER 3/8" THICK X 1'-8" WIDE X 3'-10 1/2" LONG. EXTEND PAD 1/2" BEYOND THE END OF THE BEAM AS SHOWN.

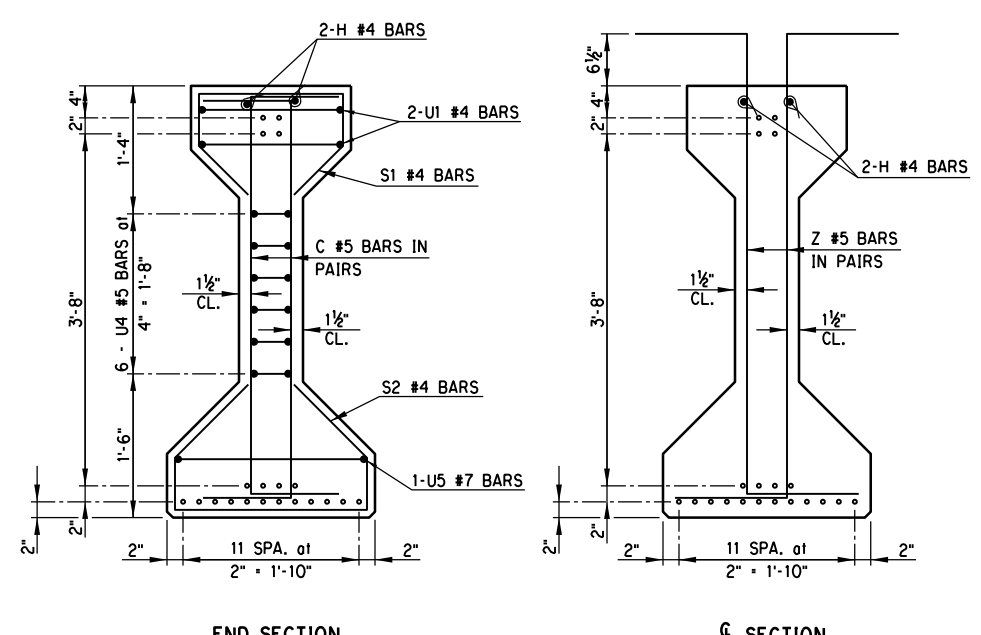

BEAM SECTIONS
(20 - 0.6" DIA. STRANDS)

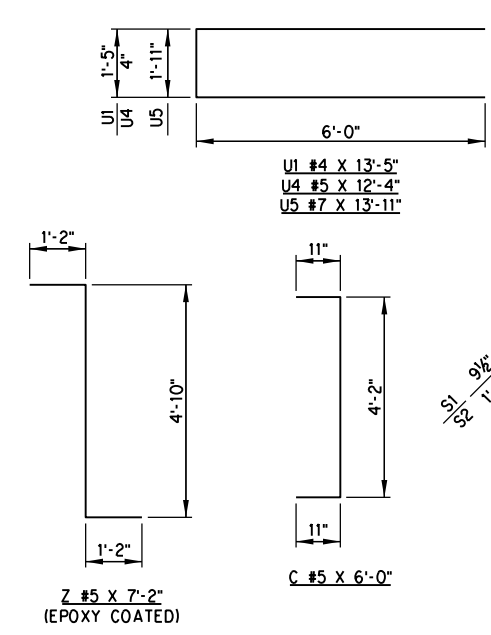

BAR BEND DETAILS

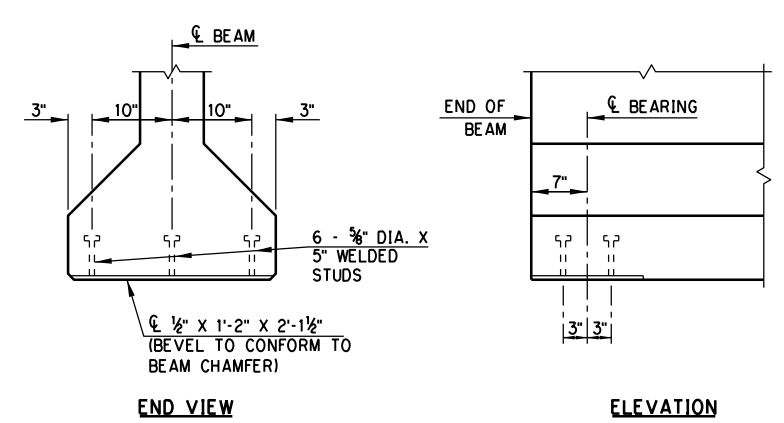

EMBEDDED SOLE PLATE DETAILS
NOTE: PROVIDE AN EMBEDDED SOLE PLATE AT EACH END OF THE BEAM

PRESTRESSED CONCRETE BEAM NOTES
COMPRESSION STRENGTH:
PROVIDE CONCRETE WITH A COMPRESSION STRENGTH OF 7,000 PSI at TRANSFER OF PRESTRESS AND 10,000 PSI at 28 DAYS.
STRAND TYPE:
PROVIDE LOW-RELAXATION STRANDS HAVING A NOMINAL DIAMETER OF 0.6" WITH ULTIMATE TENSILE STRENGTH OF 270 KSI.

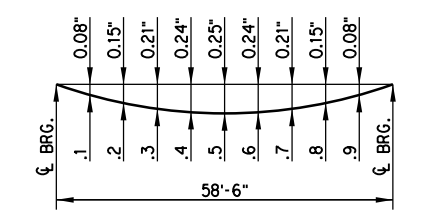

DEAD LOAD DEFLECTION DIAGRAM
NOTE: THE DEAD LOAD DEFLECTION SHOWN ABOVE OF THE TENTH POINTS ARE THE INITIAL DEFLECTIONS DUE TO DECK SLAB + DIAPHRAGMS + HAUNCH + S.I.P. STEEL DECK FORM ALLOWANCE + CONCRETE PARAPET + MEDIAN BARRIER. IT DOES NOT INCLUDE THE BEAM WEIGHT OR FUTURE WEARING SURFACE.

3/1/2024 2:26:43 PM H:\PROJECTS\2789_CrossRoads_Phase 4\Bridges\Drawings\Ph4 Bridges\Bridges\0903208 P4 Bridge D Beam.dgn

DESIGN		PHASE 4	OKLAHOMA COUNTY
DRAWN		BRIDGE "D"	1-240 OVER 1-35
CHECKED		TYPE IV P.C.B. DETAILS	
APPROVED		SPANS 1 & 4 (SHEET 2 OF 2)	
SQUAD	POE	STATE JOB NO. 09032108	SHEET NO. B125

NOTE: FOR DETAIL OF LIFTING EYE AND INTENTIONALLY ROUGHENED SURFACE DETAILS, SEE SHEET 1 OF 2.

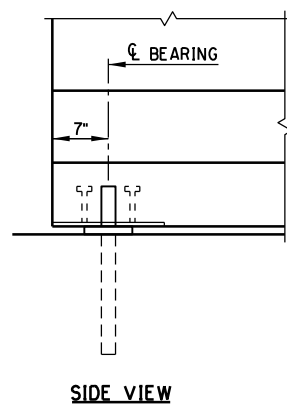
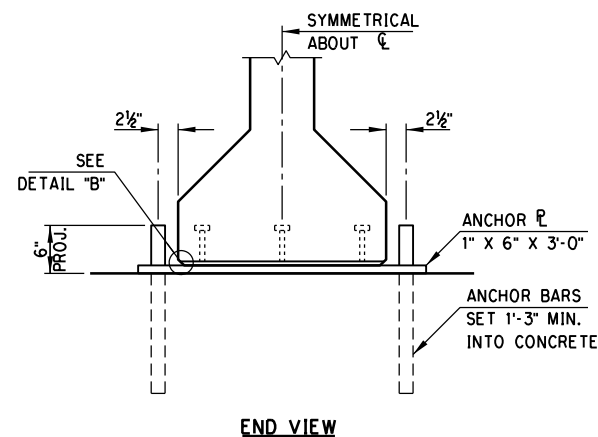
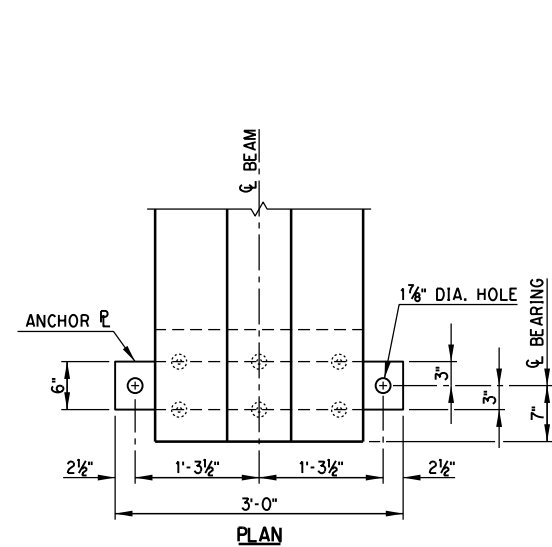
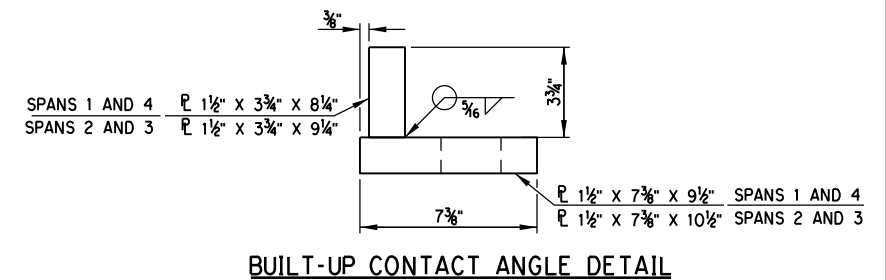
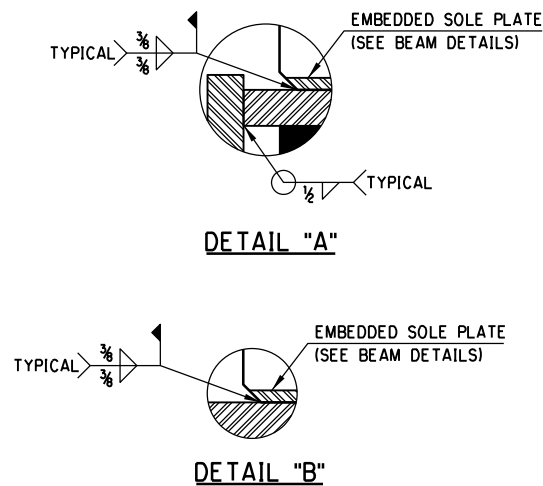
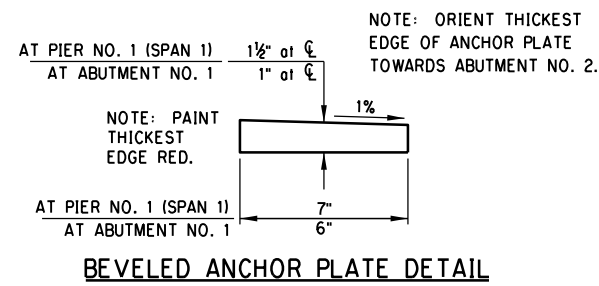
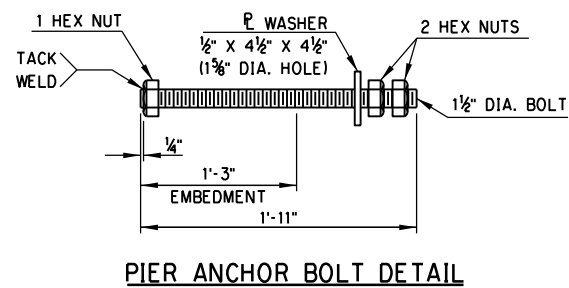
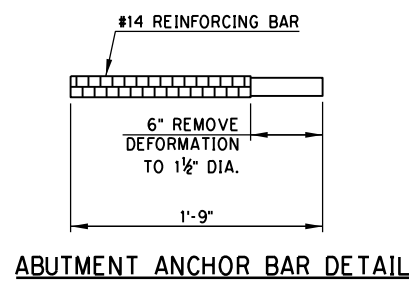

ABUTMENT FIXED BEARING DETAILS

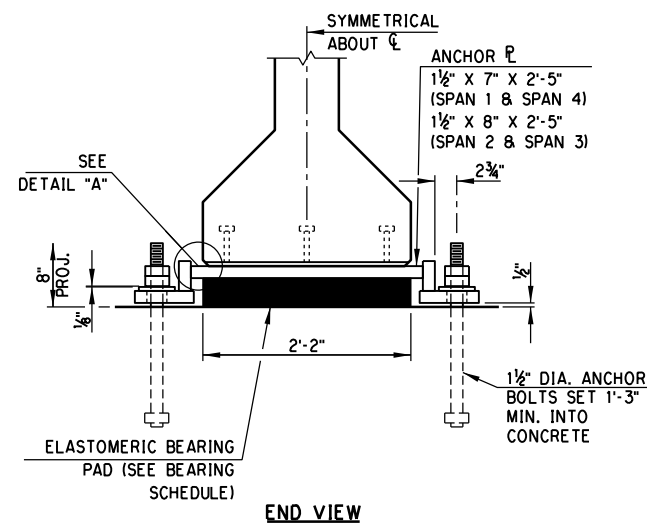
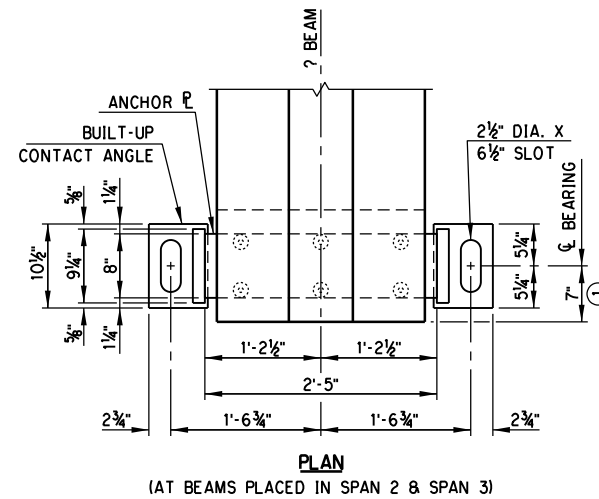

PIER EXPANSION BEARING DETAILS

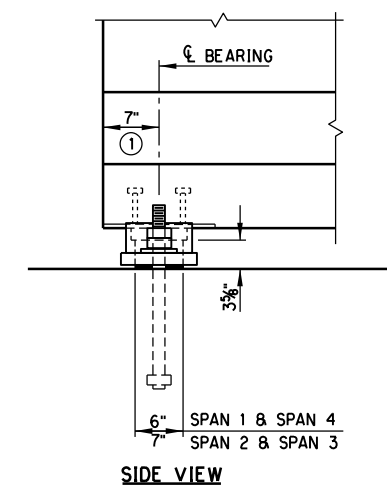
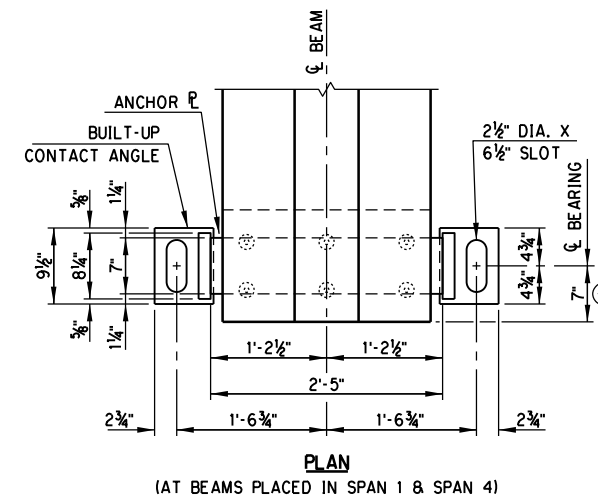

LOCATION	SIZE (T _x LxW)	COVER LAYERS	INTERNAL LAYERS	LAMINATE LAYERS
SPANS 1 & 4	3 5/8" x 6" x 2'-2"	2 at 1/4"	6 at 3/8"	7 at 1/8"
SPANS 2 & 3	3 5/8" x 7" x 2'-2"	2 at 1/4"	6 at 3/8"	7 at 1/8"

EXPANSION BEARING ASSEMBLY NOTES
 PROVIDE STRUCTURAL STEEL FOR ANCHOR PLATES, WASHER PLATES, AND BUILT-UP CONTACT ANGLES IN ACCORDANCE WITH ASTM A240 (AUSTENITIC STAINLESS STEEL, TYPE 316, CHARPY V-NOTCH TESTING NOT REQUIRED). FOR ANCHOR BOLTS, PROVIDE CONTINUOUSLY THREADED BARS IN ACCORDANCE WITH ASTM A320, CLASS 2, GRADE B8M (AUSTENITIC STAINLESS STEEL, TYPE 316, CHARPY V-NOTCH TESTING NOT REQUIRED). USE AUSTENITIC STAINLESS STEEL NUTS CONFORMING TO ASTM A194, GRADE 8M. PERFORM ALL WELDING CONSISTENT WITH PROCEDURES FOR STAINLESS STEEL.

FIXED BEARING ASSEMBLY NOTES
 PROVIDE STRUCTURAL STEEL FOR ANCHOR PLATES IN ACCORDANCE WITH AASHTO M270 (ASTM A709), GRADE 50W (WEATHERING STEEL, CHARPY V-NOTCH TESTING NOT REQUIRED). FOR ANCHOR BARS, PROVIDE A REINFORCING BAR IN ACCORDANCE WITH AASHTO M31, GRADE 60.

① CENTER ANCHOR BOLTS IN SLOTS DURING SETTING OF BEAMS. DIMENSION MAY VARY DEPENDING ON TEMPERATURE AT THE TIME OF BEAM SETTING.

DESIGN	POE
DRAWN	
CHECKED	
APPROVED	
SQUAD	POE

PHASE 4
 BRIDGE "D"
 OKLAHOMA COUNTY
 I-240 OVER I-35

BEARING ASSEMBLY DETAILS

STATE JOB NO. O9032108 SHEET NO. B126

3/1/2024 2:26:45 PM H:\PROJECTS\2789_CrossRoads_Phase 4 Bridge Drawings\Ph4 Bridges\Bridges\Bridg D Bear.Ing.dgn

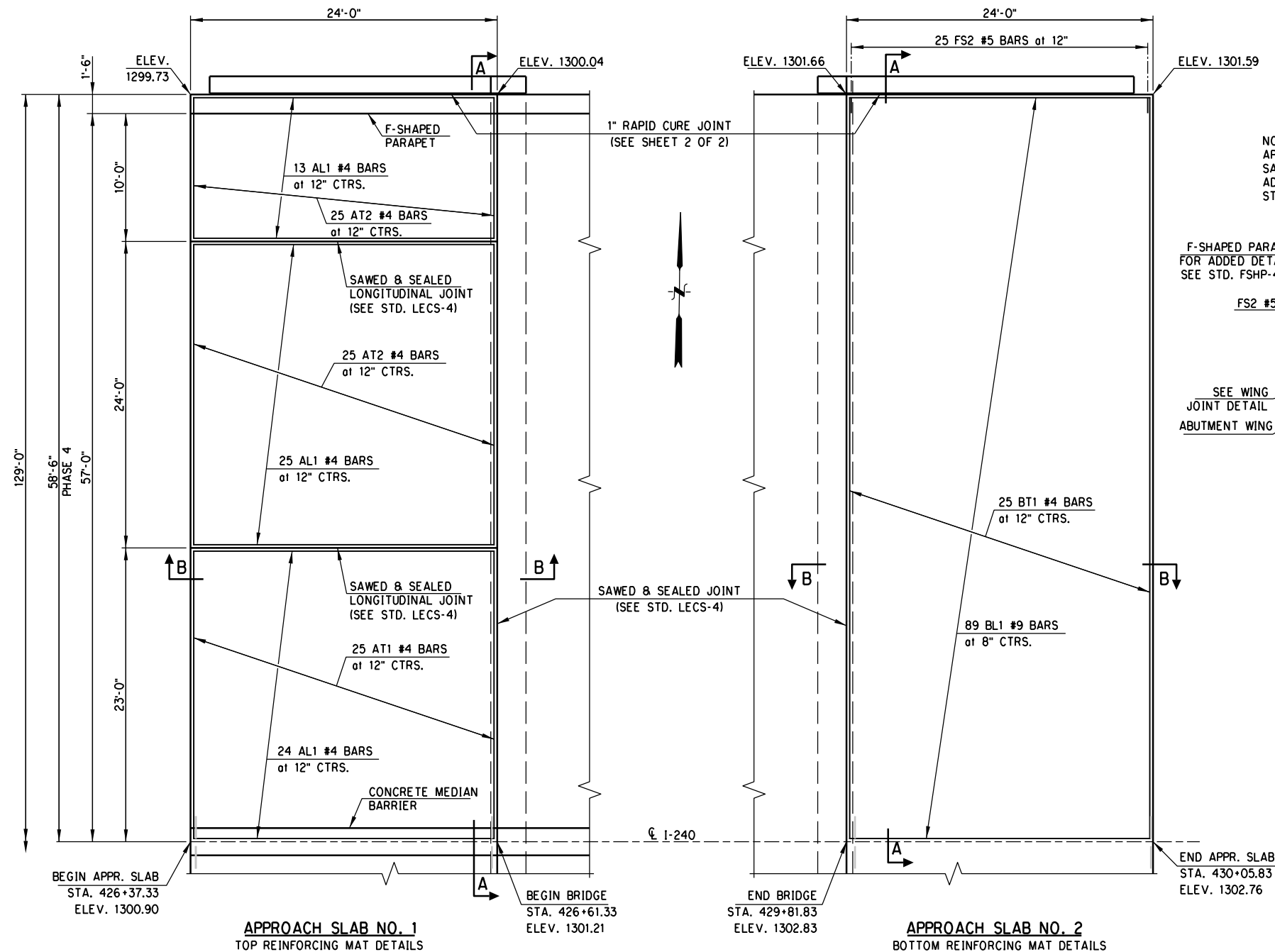

NOTE: PLACE REINFORCING IN THE TOP OF THE APPROACH SLAB 2" FROM EITHER SIDE OF THE SAWED AND SEALED LONGITUDINAL JOINT. FOR ADDITIONAL DETAILS OF LONGITUDINAL JOINT, SEE STANDARD LECS-4.

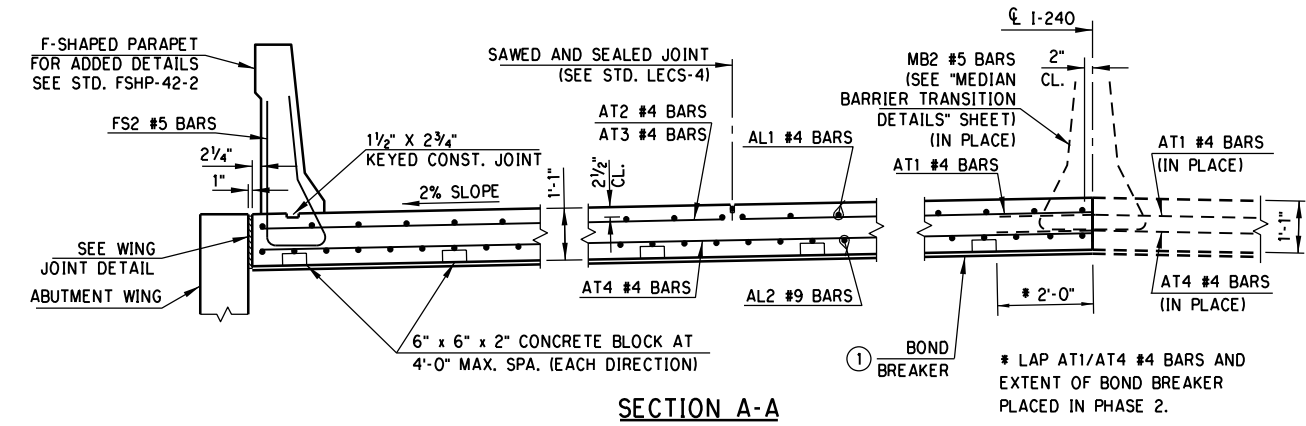

QUANTITIES				
ITEM	UNIT	ABUT. 1	ABUT. 2	TOTAL
APPROACH SLAB	S.Y.	156.00	156.00	312.00
SAW-CUT GROOVING	S.Y.	150.00	150.00	300.00
42" F-SHAPED PARAPET	L.F.	24.00	24.00	48.00
WATER REPELLENT (VISUALLY INSPECTED)	S.F.	34.00	34.00	68.00

NOTES:

CONCRETE FOR APPROACH SLABS SHALL BE CLASS AA. REINFORCING STEEL SHALL BE GRADE 60.

ALL COST OF MATERIALS, LABOR, AND INCIDENTALS NECESSARY TO COMPLETE THE WORK AS SHOWN SHALL BE INCLUDED IN THE UNIT PRICE BID PER SQUARE YARD OF APPROACH SLAB. THIS PRICE BID SHALL INCLUDE THE COST OF LOAD TRANSFER UNIT, POLYSTYRENE, RAPID CURE JOINT SEALANT, BACKER RODS, SAWING, DOWEL BLOCKS, POLYETHYLENE SHEETING, CLASS AA CONCRETE AND EPOXY COATED REINFORCING STEEL (INCLUDING FS2 PARAPET BARS).

ALL COST OF PARAPET SHALL BE INCLUDED IN PRICE BID PER L.F. OF "42" F-SHAPED PARAPET". THIS PRICE SHALL INCLUDE COST OF ALL FS1, FH1 AND FH2 EPOXY COATED REINFORCING STEEL. PARAPET SHALL BE FULL HEIGHT FOR THE LENGTH OF THE APPROACH SLAB.

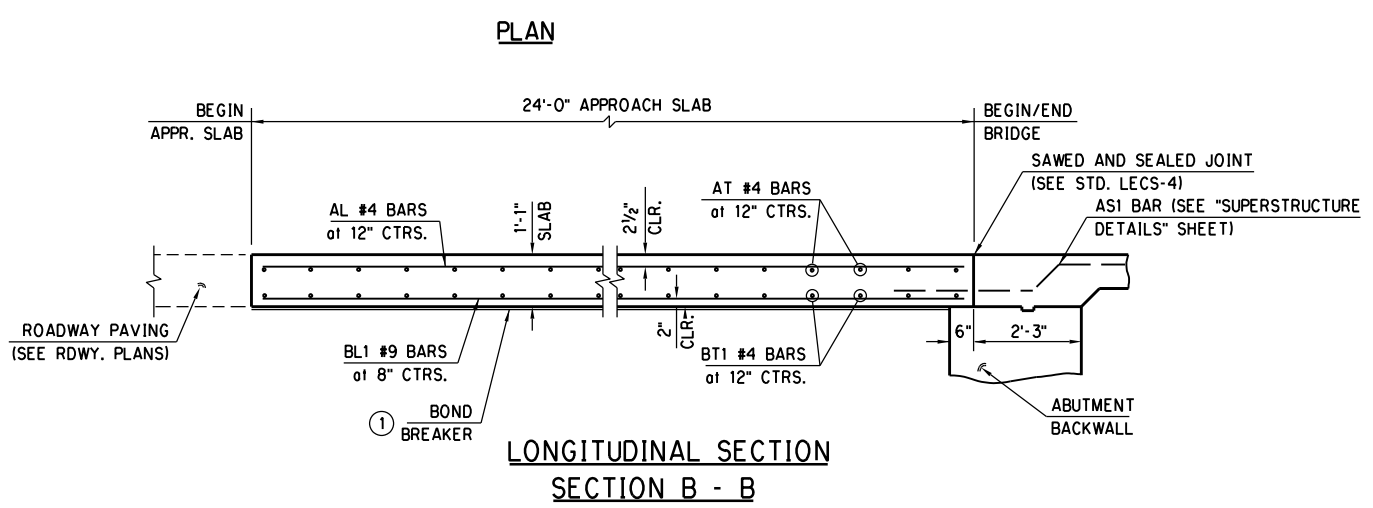

NOTE: PHASE 2 APPR. SLAB REINFORCING NOT SHOWN FOR CLARITY.

NOTE: FOR ADDITIONAL DETAILS AT ABUTMENT DIAPHRAGM SEE "SUPERSTRUCTURE DETAILS" SHEET 3 OF 4.

DESIGN		PHASE 4	OKLAHOMA COUNTY
DRAWN		BRIDGE "D"	I-240 OVER 1-35
CHECKED		APPROACH SLAB DETAILS (SHEET 1 OF 2)	
APPROVED		STATE JOB NO. 09032(08) SHEET NO. B127	
SQUAD	POE		

3/1/2024 2:26:46 PM H:\PROJECTS\2789_CrossRoads\Phase 4\Bridges\Drawings\Phase 4\Bridges\Bridges\Bridges\Phase 4\Approach.dgn

**90% PLAN
SUBMITTAL**
2/29/2024

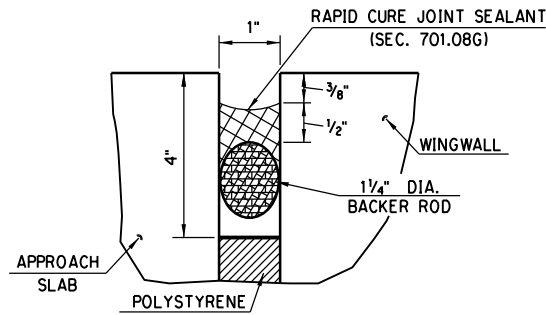

**DETAIL OF RAPID
CURE JOINT
AT WINGWALLS**

NOTE: FOR BACKER ROD AND JOINT SEALER
GENERAL NOTES REFER TO STD. LECS-4.

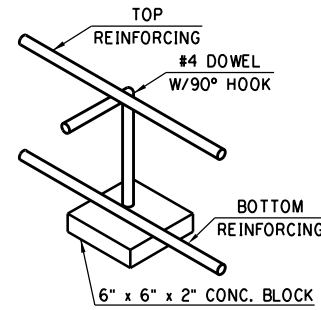

DOWEL BLOCK

NOTE: CONTRACTOR MAY USE APPROVED HIGH
CHAIRS WITH SAND PLATES (HCP) AND 6" x 6" x 2"
PLAIN CONCRETE BLOCKS IN LIEU OF DOWEL
BLOCKS SHOWN. SPACING SHALL BE 4'-0" MAX.
ON CTRS.

BAR LIST - EPOXY COATED					
ONE SHOWN TWO REQUIRED (FOR INFORMATION ONLY)					
MARK	NO.	SIZE	FORM	SPACING	LENGTH
AL1	62	#4	STR.	12" C/C	23'-10"
AT1	25	#4	STR.	12" C/C	22'-10"
AT4	25	#4	STR.	12" C/C	23'-8"
AT5	25	#4	STR.	12" C/C	11'-2"
BL1	89	#9	STR.	8" C/C	23'-8"
BT1	25	#4	STR.	12" C/C	58'-10"
FS2	25	#5	BNT.	12 C/C	7'-4"

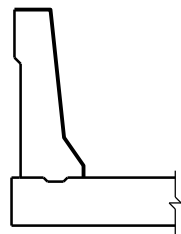

**WATER REPELLENT
SURFACE TREATMENT**

SURFACES INDICATED WITH HEAVY LINES
SHALL BE TREATED WITH A PENETRATING
WATER REPELLENT SURFACE TREATMENT.

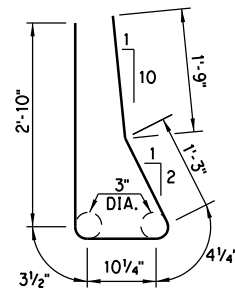

FS2 #5 x 7'-4"

NOTE: FOR FS2 BAR BENDS, SEE
STANDARD FSHP-42-2.

NOTE: FS2 BARS SHALL BE TIED IN PLACE BEFORE
POURING THE CONCRETE FOR THE APPROACH SLAB.

NOTE: ALL BENT BAR DIMENSIONS
ARE OUT TO OUT.

3/1/2024 2:26:48 PM H:\PROJECTS\2789_CrossRoads_Phase 4\Bridges\Drawings\Ph4 Bridges\Bridges\0903208 P4 Bridge D Approach.dgn

DESIGN		PHASE 4	OKLAHOMA COUNTY
DRAWN		BRIDGE "D"	1-240 OVER 1-35
CHECKED		APPROACH SLAB DETAILS (SHEET 2 OF 2)	
APPROVED			
SQUAD	POE	STATE JOB NO. 09032(08)	SHEET NO. B128

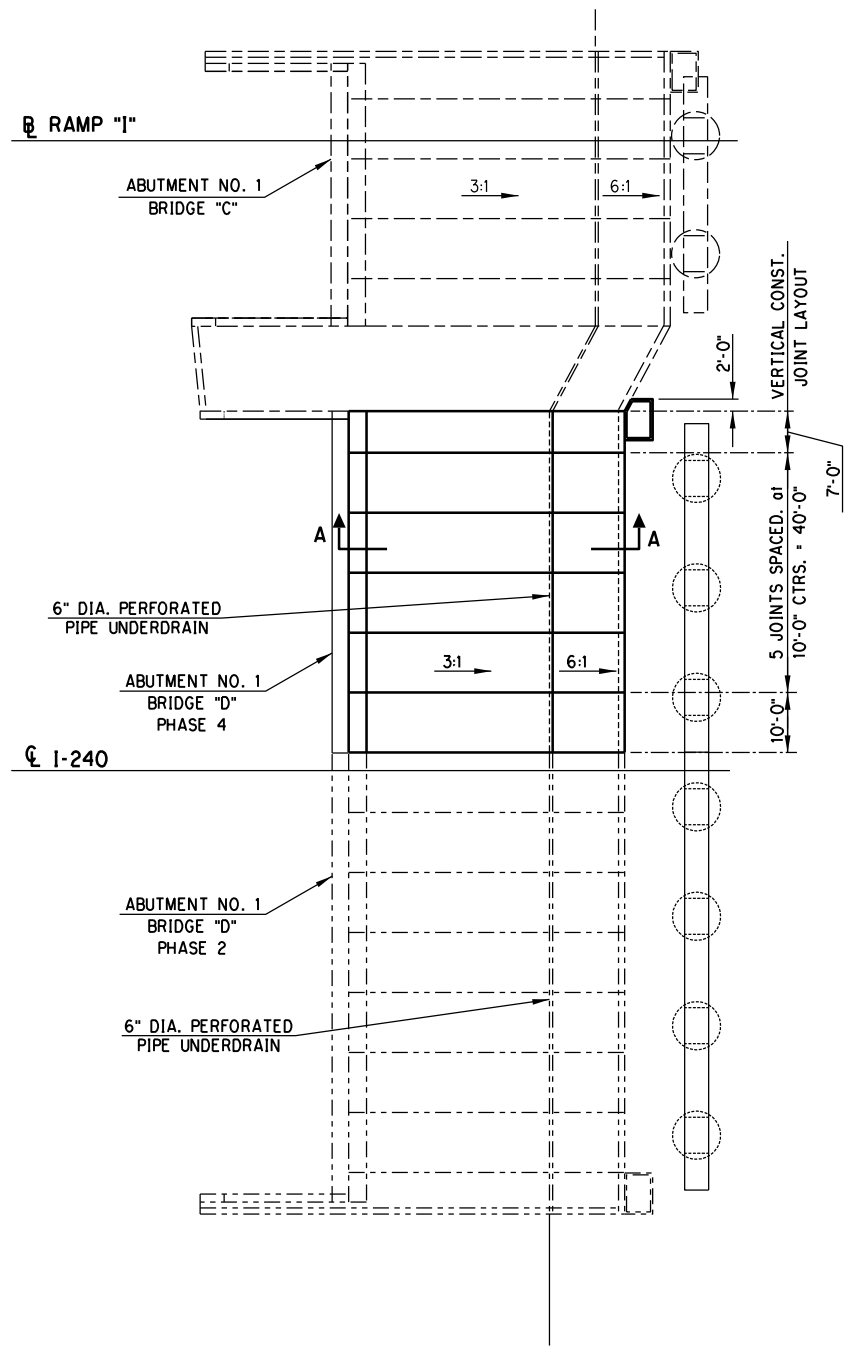

**SLOPE WALL PLAN
AT ABUTMENT NO. 1**

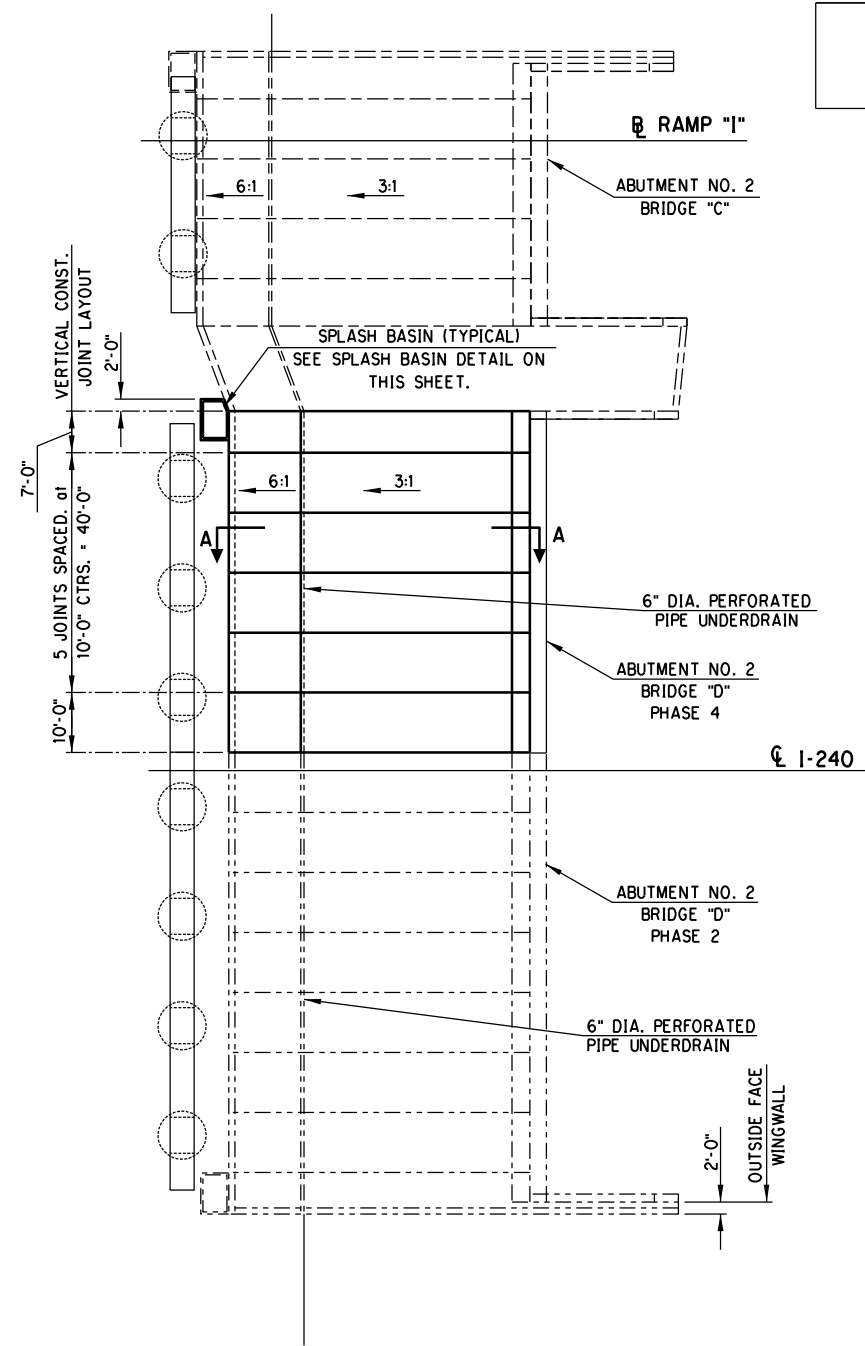

**SLOPE WALL PLAN
AT ABUTMENT NO. 2**

FOR SECTION A-A. SEE SHEET 2 OF 2.

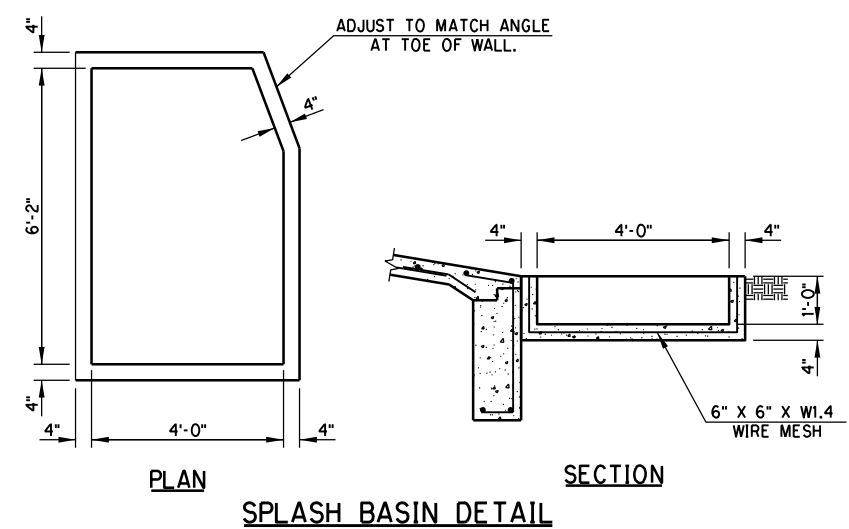

SPLASH BASIN DETAIL

QUANTITIES				
ITEM	UNIT	ABUT. 1	ABUT. 2	TOTAL
CLASS C CONCRETE	C.Y.	1.00	1.00	2.00
SLOPE WALL (5")	S.Y.	309.00	343.00	652.00
6" PERFORATED PIPE UNDERDRAIN ROUND	L.F.	57.00	57.00	114.00

DESIGN		PHASE 4	OKLAHOMA COUNTY
DRAWN		BRIDGE "D"	I-240 OVER I-35
CHECKED		SLOPEWALL DETAILS (SHEET 1 OF 2)	
APPROVED			
SQUAD	POE		
		STATE JOB NO. 09032(08)	SHEET NO. B129

3/1/2024 2:26:49 PM H:\PROJECTS\2789_CrossRoads_Phase 4\Bridges\Drawings\Ph4 Bridges\Bridges\I-240 Bridge D SlopeWall.dgn

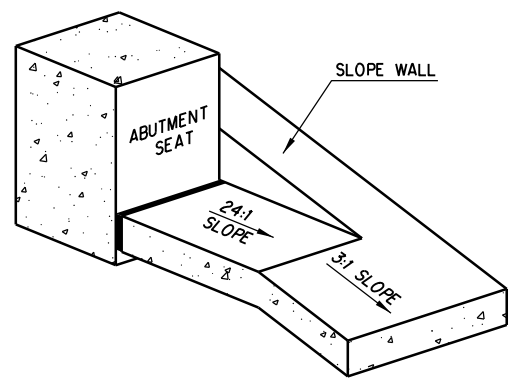
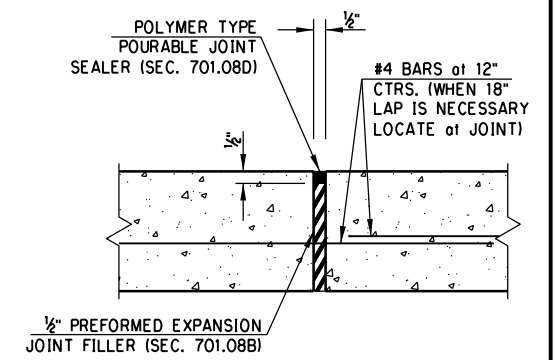
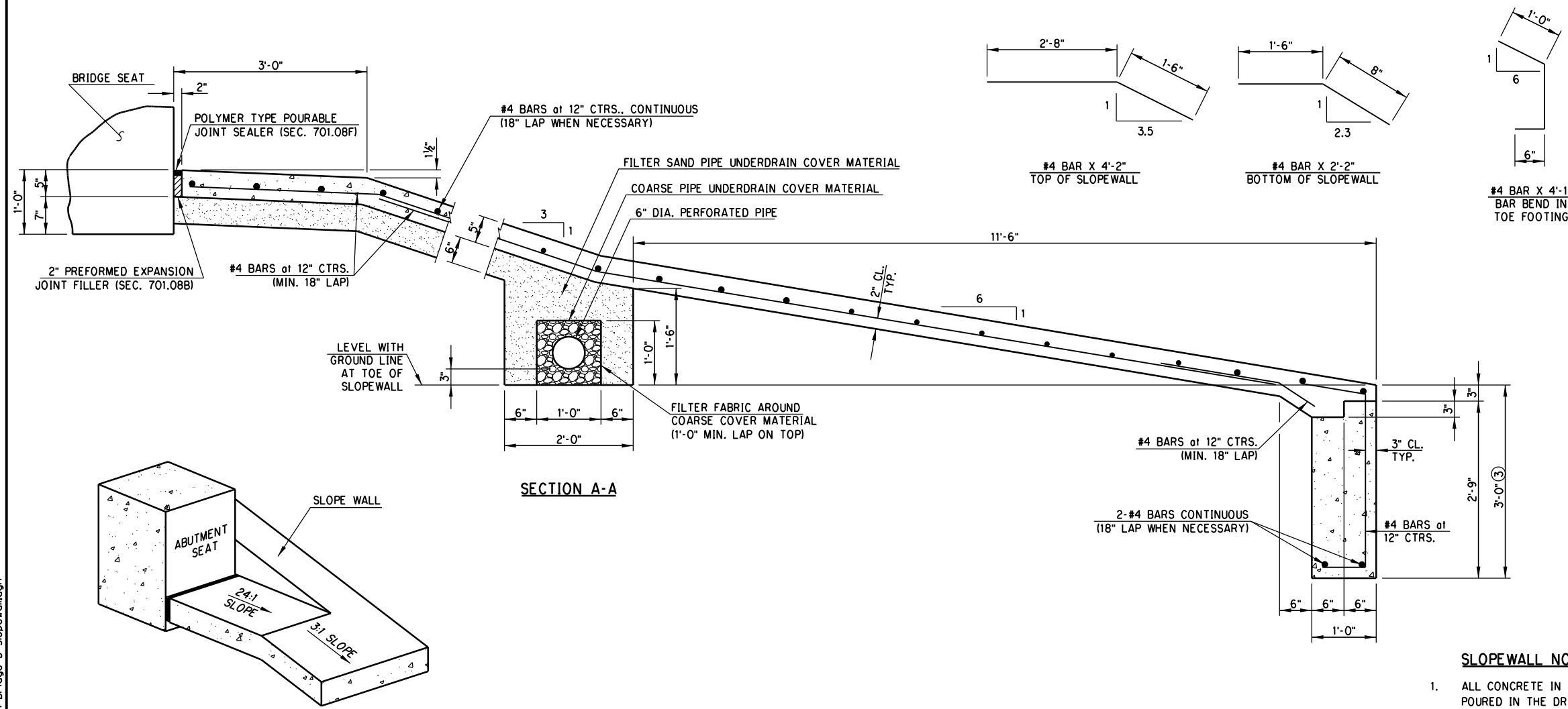

SLOPEWALL NOTES

1. ALL CONCRETE IN THE SLOPE WALL SHALL BE CLASS A CONCRETE AND SHALL BE Poured IN THE DRY. ALL CONSTRUCTION SHALL BE IN ACCORDANCE WITH SECTIONS 509 AND 610 OF THE STANDARD SPECIFICATIONS.
2. NO HORIZONTAL CONSTRUCTION JOINTS WILL BE PERMITTED IN THE SLOPE WALL. FINAL NUMBER AND LOCATION OF VERTICAL CONSTRUCTION JOINTS WILL BE DETERMINED IN THE FIELD BY THE ENGINEER.
3. SURFACE AREA OF TOE AND EDGES OF SLOPE WALL INCLUDED IN PAY QUANTITY SHOWN.
4. ALL COSTS OF THE JOINT SEALER AND FILLER, REINFORCING STEEL, CONCRETE, EXCAVATION, FILTER SAND UNDERDRAIN COVER MATERIAL, LABOR, FORMS AND INCIDENTALS NECESSARY TO COMPLETE THE WORK AS SHOWN, SHALL BE INCLUDED IN THE CONTRACT PRICE BID OFR SLOPE WALL (5').
5. SPLASH BASINS WILL BE MEASURED BY THE CUBIC YARDS OF CLASS "C" CONCRETE REQUIRED TO CONSTRUCT BASINS AS SHOWN IN THE PLANS.

3/1/2024 2:26:21 PM H:\PROJECTS\2789_CrossRoads_Phase 4\Bridges\Drawings\Ph4 Bridges\Bridg D SlopeWall.dgn

PHASE 4		OKLAHOMA COUNTY	
BRIDGE "D"		I-240 OVER I-35	
DESIGN		SLOPEWALL DETAILS (SHEET 2 OF 2) STATE JOB NO. 09032(08) SHEET NO. B130	
DRAWN			
CHECKED			
APPROVED			
SQUAD	POE		

DESIGN DATA

DESIGN SPECIFICATIONS:
AASHTO LRFD BRIDGE DESIGN SPECIFICATIONS, 7TH EDITION
ANSI/AASHTO/AWS D1.5 BRIDGE WELDING CODE
ANSI/AWS D1.6 STRUCTURAL WELDING CODE STAINLESS STEEL

UNIT STRESSES:
CLASS AA CONCRETE F_c = 4,000 PSI
CLASS A CONCRETE F_c = 3,000 PSI
CLASS P CONCRETE F_c = 4,000 PSI
REINFORCING STEEL (GRADE 60) F_y = 60,000 PSI
STRUCTURAL STEEL M270 (GRADE 50W) F_c = 50,000 PSI
STAINLESS STEEL A240 (TYPE 316) F_y = 30,000 PSI

LOADING:
HL-93
75 PSF FUTURE 6" STRUCTURAL OVERLAY
5 PSF SIP STEEL DECK FORM ALLOWANCE

LRFR OF HL-93 LOADING:
INVENTORY RATING FACTOR = 1.25
OPERATING RATING FACTOR = 1.83

FOUNDATION CAPACITIES

ABUTMENTS:	ABUT. 1	ABUT. 2
DRILLED SHAFT DIAMETER *	42"	42"
DRILLED SHAFT DIAMETER *	30"	30"
DRILLED SHAFT MINIMUM DEPTH INTO ROCK *	5'-0"	5'-0"
FACTORED REACTION *	252 TONS	264 TONS
NOMINAL UNIT BEARING RESISTANCE *	60.00 TSF	60.00 TSF
BEARING RESISTANCE FACTOR *	0.70	0.70
FACTORED BEARING RESISTANCE *	404 TONS	404 TONS
NOMINAL UNIT FRICTION RESISTANCE *	9 TSF	9 TSF
FRICTION RESISTANCE FACTOR *	0.45	0.45
FACTORED FRICTION RESISTANCE *	89 TONS	89 TONS
DEPTH OF SHALE NEGLECTED FOR FRICTION *	3 FT.	3 FT.
TOTAL FACTORED RESISTANCE *	493 TONS	493 TONS

PIERS:	PIER 1	PIER 2
DRILLED SHAFT DIAMETER *	84"	84"
DRILLED SHAFT MINIMUM DEPTH INTO ROCK *	14'-0"	16'-0"
FACTORED REACTION *	1900 TONS	1914 TONS
NOMINAL UNIT BEARING RESISTANCE *	60.00 TSF	60.00 TSF
BEARING RESISTANCE FACTOR *	0.56	0.56
FACTORED BEARING RESISTANCE *	1293 TONS	1293 TONS
NOMINAL UNIT FRICTION RESISTANCE *	8.4 TSF	6.25 TSF
FRICTION RESISTANCE FACTOR *	0.44	0.44
FACTORED FRICTION RESISTANCE *	731 TONS	725 TONS
DEPTH OF SHALE NEGLECTED FOR FRICTION *	5 FT.	5 FT.
TOTAL FACTORED RESISTANCE *	2024 TONS	2018 TONS

BRIDGE "L" PHASE 4 INDEX OF SHEETS

SHEET NO.	DESCRIPTION
AB07	SUMMARY OF PAY QUANTITIES (BRIDGE)
AB08	GENERAL NOTES (BRIDGE)
B131	GENERAL PLAN & ELEVATION
B132	DESIGN DATA AND SUMMARY OF BRIDGE QUANTITIES
B133-B134	FOUNDATION REPORT
B135	SUBSTRUCTURE LAYOUT
B136	EXCAVATION DIAGRAMS AND UNDERDRAIN DETAILS
B137	ABUTMENT FOOTING DETAILS
B138	ABUTMENT WING SUPPORT DETAILS
B139-B144	ABUTMENT DETAILS
B145-B146	PIER DETAILS
B147-B152	SUPERSTRUCTURE DETAILS
B153-B154	PARAPET LAYOUT
B155	MISCELLANEOUS PRESTRESSING DETAILS
B156-B157	APPROACH SLAB DETAILS
B158	SLOPE WALL DETAILS
B159	DRAIN AT END OF BRIDGE DETAILS
B160	ARCHITECTURAL TREATMENT DETAILS AND SUPERSTR. PLACING SEQUENCE

SUMMARY OF BRIDGE QUANTITIES

ITEM	UNIT	ABUTS	PIERS	SUPER STR.	APPR. SLABS	SLOPE WALLS	TOTAL
SUBSTRUCTURE EXCAVATION COMMON	C.Y.	232.00	374.00	--	--	--	606.00
SUBSTRUCTURE EXCAVATION ROCK	C.Y.	--	244.00	--	--	--	244.00
CLSM BACKFILL	C.Y.	620.00	--	--	--	--	620.00
APPROACH SLAB	S.Y.	--	--	--	212.70	--	212.70
SAW-CUT GROOVING	S.Y.	--	--	1,331.00	--	--	1,331.00
42" F-SHAPED PARAPET	L.F.	--	--	827.00	120.30	--	947.30
STRUCTURAL STEEL (A36)	LB.	--	--	792.00	--	--	792.00
ELASTOMERIC BEARING PAD	EA.	8.00	--	--	--	--	8.00
CLASS AA CONCRETE	C.Y.	88.80	84.10	--	--	--	172.90
CLASS A CONCRETE	C.Y.	47.60	--	--	--	--	47.60
CLASS P CONCRETE	C.Y.	--	--	1,029.00	--	--	1,029.00
SLOPE WALL (5")	S.Y.	--	--	--	--	262.00	262.00
REINFORCING STEEL	LB.	5,956.00	--	--	--	--	5,956.00
EPOXY COATED REINFORCING STEEL	LB.	12,165.00	23,700.00	197,950.00	--	--	233,815.00
WATER REPELLENT (VISUALLY INSPECTED)	S.Y.	--	--	2,704.00	58.00	--	2,762.00
DRILLED SHAFTS 30" DIAMETER	L.F.	80.00	--	--	--	--	80.00
DRILLED SHAFTS 42" DIAMETER	L.F.	160.00	--	--	--	--	160.00
DRILLED SHAFTS 84" DIAMETER	L.F.	--	22.00	--	--	--	22.00
CROSSHOLE SONIC LOGGING	EA.	2.00	1.00	--	--	--	3.00
6" PERFORATED PIPE UNDERDRAIN ROUND	L.F.	68.00	--	--	--	34.70	102.70
6" NON-PERF. PIPE UNDERDRAIN RND.	L.F.	40.00	--	--	--	20.00	60.00

2009 BRIDGE STANDARDS

STD. FSHP-42-2

2019 ROADWAY STANDARDS

STD. PUD-4
STD. SPI-5

3/4/2024 2:50:42 PM H:\PROJECTS\2789_CrossRoads_Phase 4\Bridges\Drawings\Phase 4\Bridges\Bridges L\0903208 P4 Br L GPE.dgn

PHASE 4		OKLAHOMA COUNTY	
DESIGN		BRIDGE "L"	RAMP "L" OVER RAMP "A"
DRAWN		DESIGN DATA AND SUMMARY OF QUANTITIES STATE JOB NO. 09032(08) SHEET NO. B132	
CHECKED			
APPROVED			
SQUAD	POE		

Boring Number L-1
Northing: 143127.77
Easting: 2149242.89
Date Drilled: 01/30/19

Boring Number L-2
Northing: 143136
Easting: 2149370
Date Drilled: 05/10/19

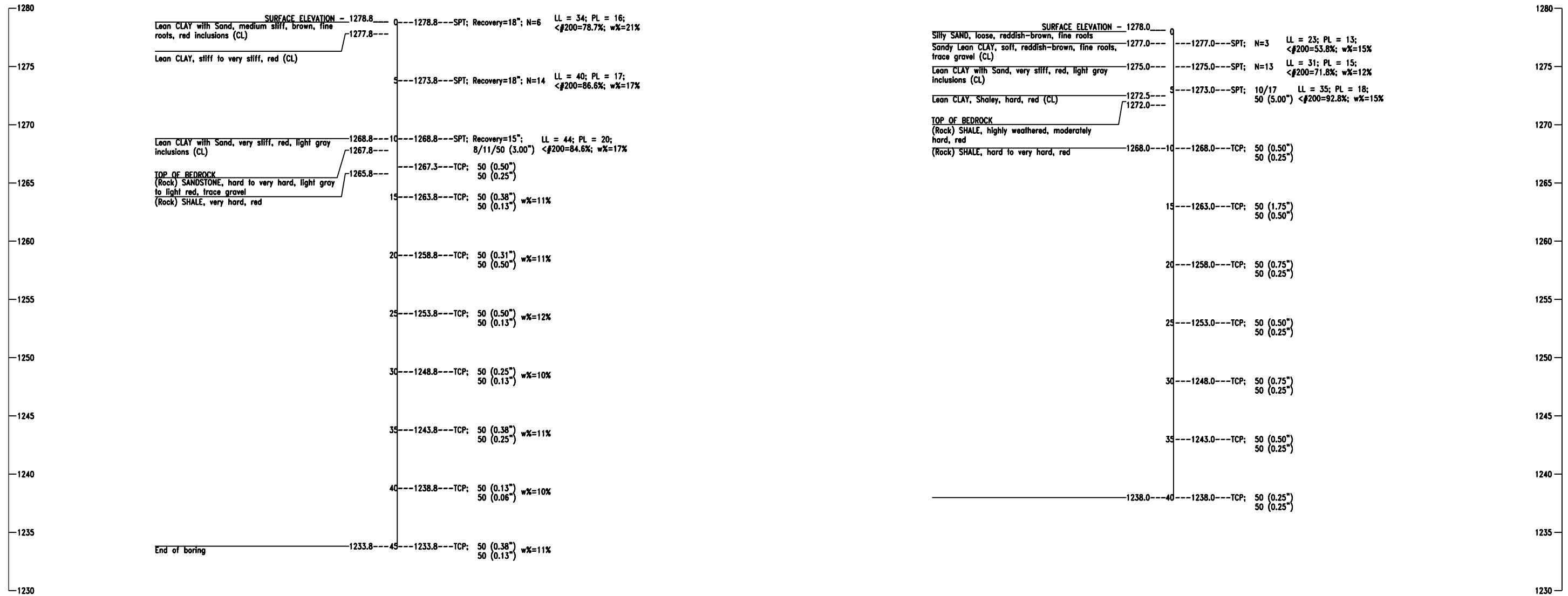

GEOLOGIC STATEMENT

"Division Four" of the "Engineering Classification of Geological Materials", published by the Oklahoma Department of Transportation (ODOT) indicates that the site is underlain by the Hennessey Unit (Phy). The geologic unit is described below. This unit consists of red platy to blocky clay shales and mudstone. The mudstones are hard and appear blocky. The red clay shale of the Hennessey Unit is characterized by numerous bands of streaks of white or light green color ranging from a few inches to four feet in thickness. The total thickness of the unit is about 400 feet. The Hennessey Unit outcrops in a 5- to 15-mile north-south band across Grant, Garfield, Kingfisher, Logan, Canadian, and Oklahoma Counties in Division Four. Topographically, the unit is near level to gently rolling and is generally grass covered or cultivated.

GEOTECHNICAL REPORT

All geotechnical information contained on this sheet is covered by the engineering seal affixed to an original geotechnical engineering report that has been stamped and sealed by a professional engineer licensed in Oklahoma. To obtain a copy of the complete report, contact the ODOT office engineer at (405) 521-2625. The contractor should be fully aware of the site conditions prior to beginning work. Any additional geotechnical information which may be desired is the responsibility of the contractor.

Note: Water level elevations shown were obtained at the time the borings were drilled and may fluctuate throughout the year.

NOTE: SPT - Split Spoon Sampling <#200 - Percent passing #200 sieve
TCP - Texas Cone Penetator Test w% - Moisture content
AUG - Augur Cutting Sample N - Number of blows per 12 inches
LL - Liquid Limit PL - Plastic Limit
Denotes depth to observed groundwater

DESIGN		BRIDGE "L"	RAMP "L" OVER RAMP "A"
DRAWN		FOUNDATION REPORT (SHEET 1 OF 2)	
CHECKED			
APPROVED			
SQUAD	PSI		
STATE JOB NO. 09032(08)		SHEET NO. B133	

Boring Number L-3
 Northing: 143084
 Easting: 2149528
 Date Drilled: 04/14/19

Boring Number L-4
 Northing: 143034.33
 Easting: 2149646.28
 Date Drilled: 01/30/19

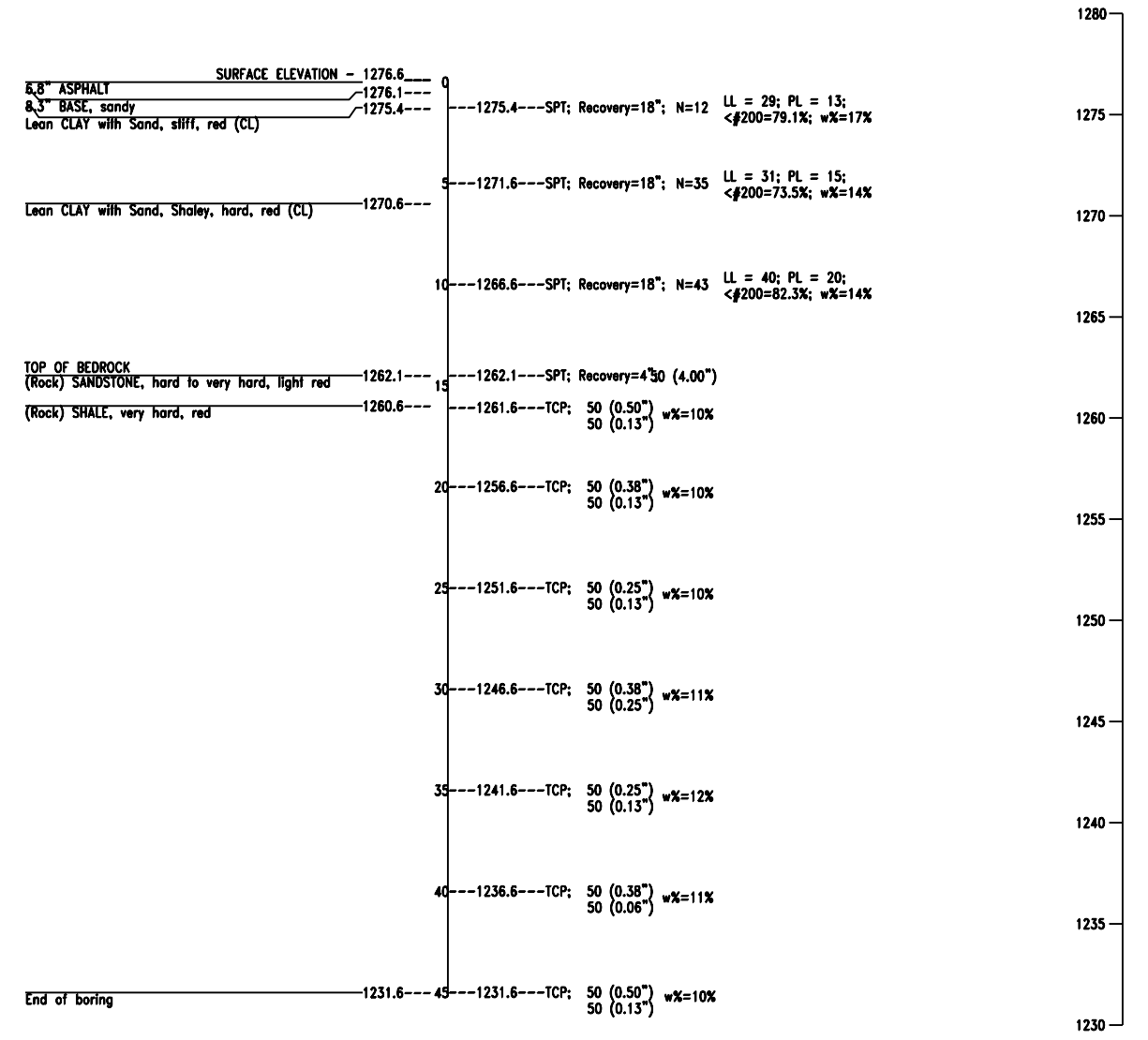
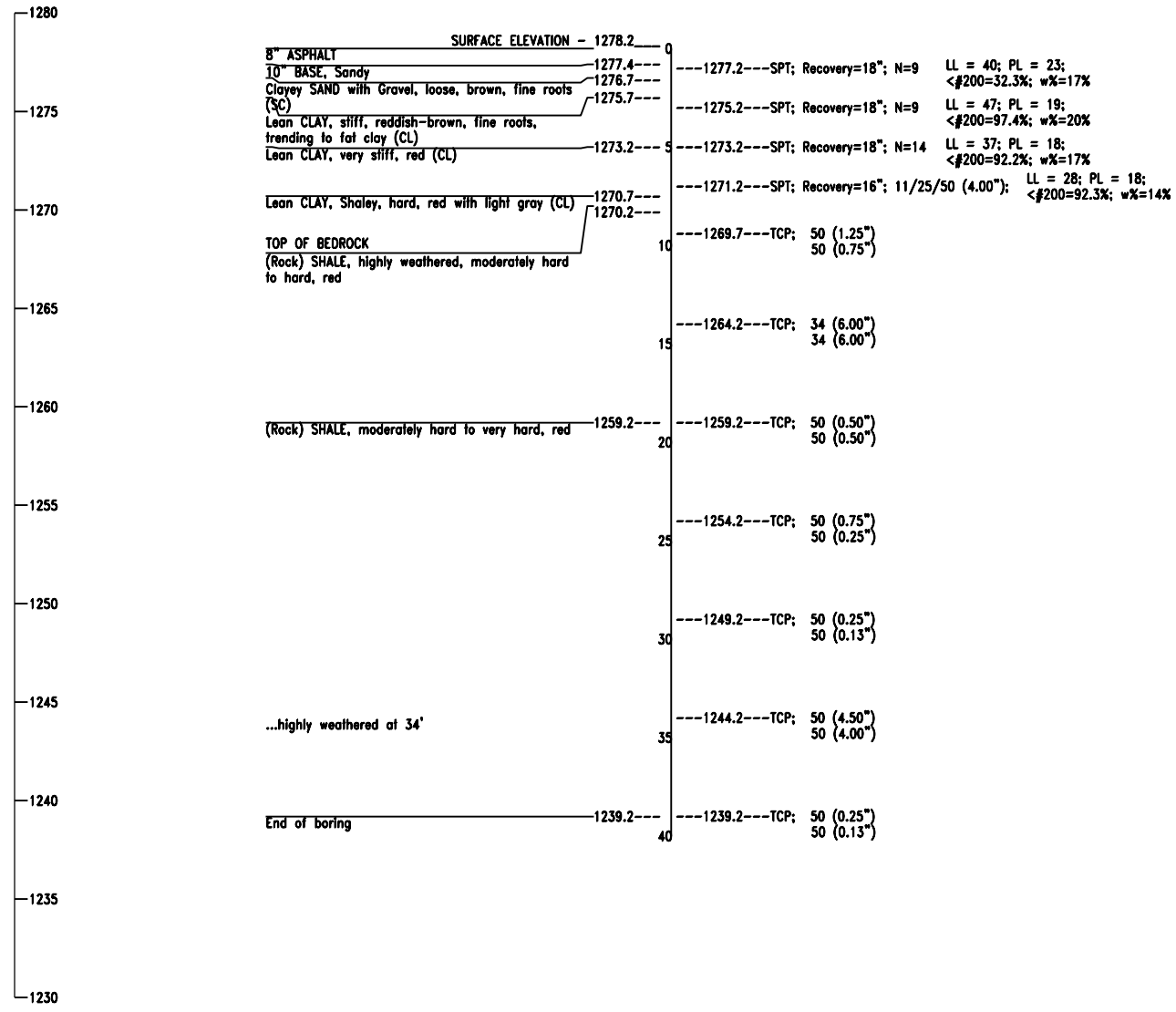

GEOLOGIC STATEMENT

"Division Four" of the "Engineering Classification of Geological Materials", published by the Oklahoma Department of Transportation (ODOT) indicates that the site is underlain by the Hennessey Unit (Phy). The geologic unit is described below.
 This unit consists of red platy to blocky clay shales and mudstone. The mudstones are hard and appear blocky. The red clay shale of the Hennessey Unit is characterized by numerous bands of streaks of white or light green color ranging from a few inches to four feet in thickness.
 The total thickness of the unit is about 400 feet.
 The Hennessey Unit outcrops in a 5- to 15-mile north-south band across Grant, Garfield, Kingfisher, Logan, Canadian, and Oklahoma Counties in Division Four. Topographically, the unit is near level to gently rolling and is generally grass covered or cultivated.

GEO TECHNICAL REPORT

All geotechnical information contained on this sheet is covered by the engineering seal affixed to an original geotechnical engineering report that has been stamped and sealed by a professional engineer licensed in Oklahoma. To obtain a copy of the complete report, contact the ODOT office engineer at (405) 521-2625. The contractor should be fully aware of the site conditions prior to beginning work. Any additional geotechnical information which may be desired is the responsibility of the contractor.

Note: Water level elevations shown were obtained at the time the borings were drilled and may fluctuate throughout the year.

NOTE: SPT - Split Spoon Sampling <#200 - Percent passing #200 sieve
 TCP - Texas Cone Penetrator Test w% - Moisture content
 AUG - Augur Cutting Sample N - Number of blows per 12 inches
 LL - Liquid Limit * Denotes depth to observed groundwater
 PL - Plastic Limit

DESIGN		PHASE 4	OKLAHOMA COUNTY
DRAWN		BRIDGE "L"	RAMP "L" OVER RAMP "A"
CHECKED		FOUNDATION REPORT (SHEET 2 OF 2)	
APPROVED			
SQUAD			
PSI		STATE JOB NO. 09032(08)	SHEET NO. B134

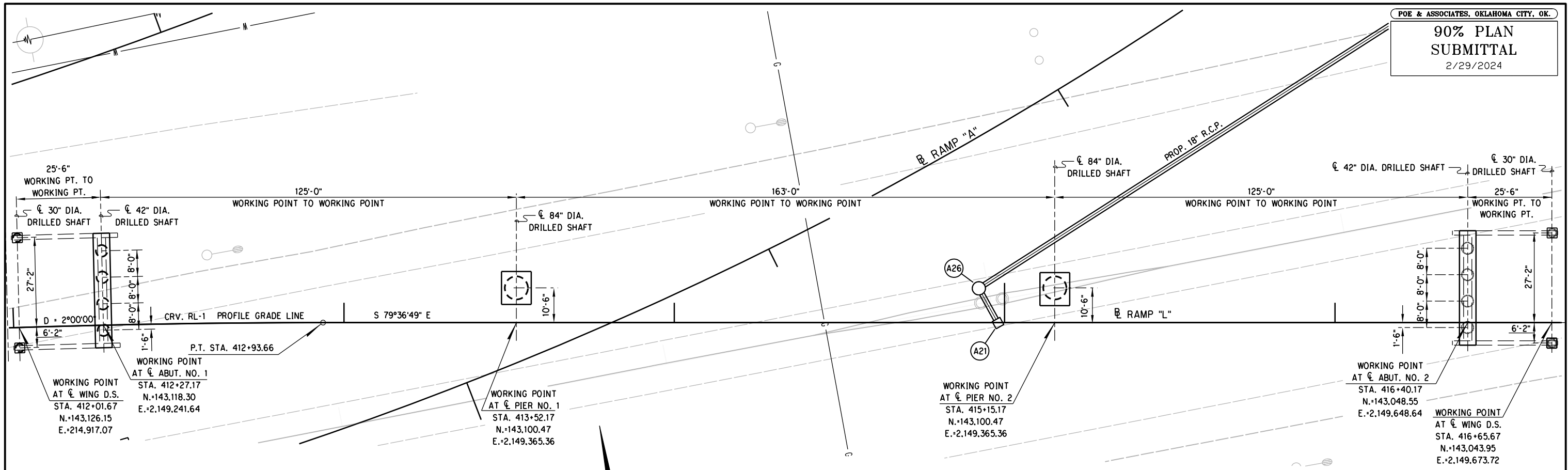

SUBSTRUCTURE STAKING DIAGRAM
SCALE: 1" = 15'-0"

3/1/2024 10:35:32 AM H:\PROJECTS\2789_CrossRoads_Phase 4\Bridges\Drawings\Ph4 Bridges\Bridges L\0903208 P4 Br L SUB.dgn

DESIGN		PHASE 4	OKLAHOMA COUNTY
DRAWN		BRIDGE "L"	RAMP "L" OVER RAMP "A"
CHECKED		SUBSTRUCTURE LAYOUT	
APPROVED			
SQUAD	POE		
		STATE JOB NO. 09032(08)	SHEET NO. B135

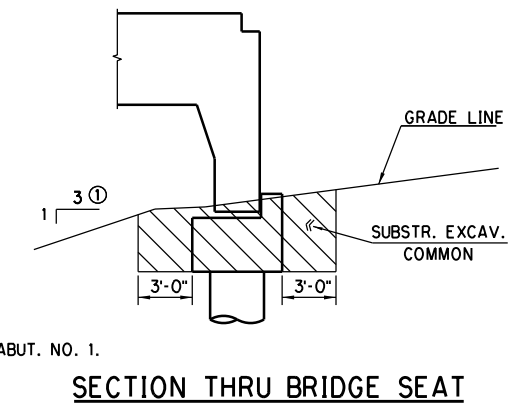
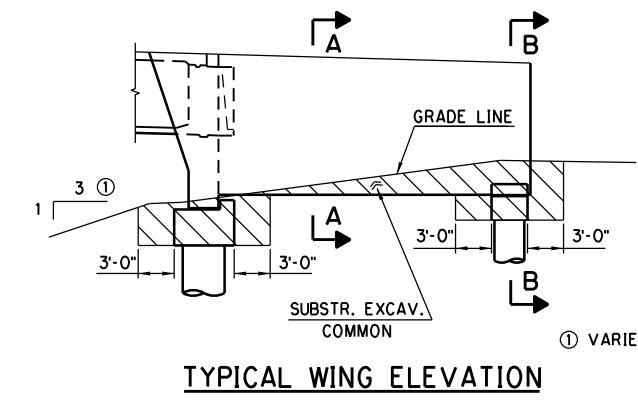
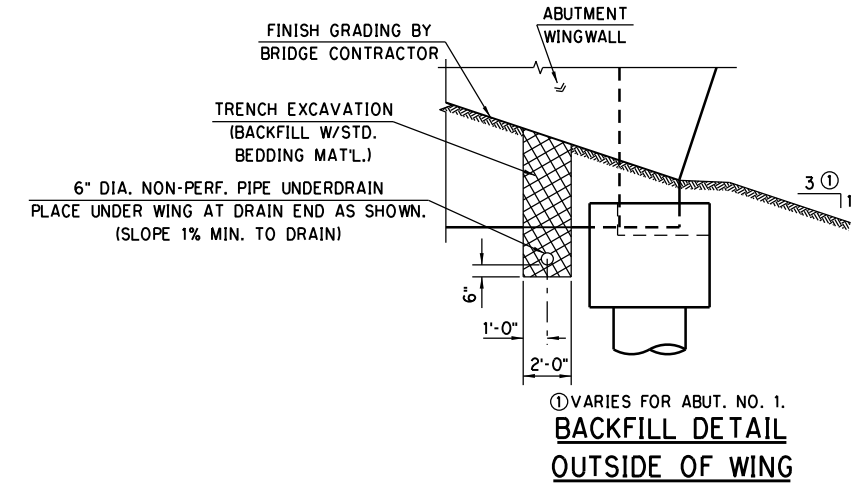
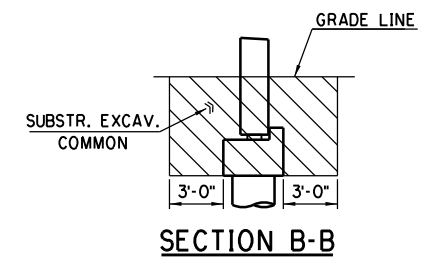
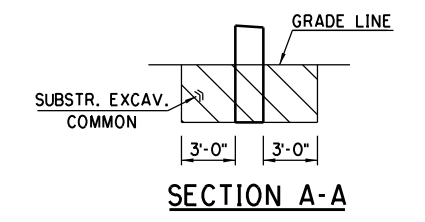
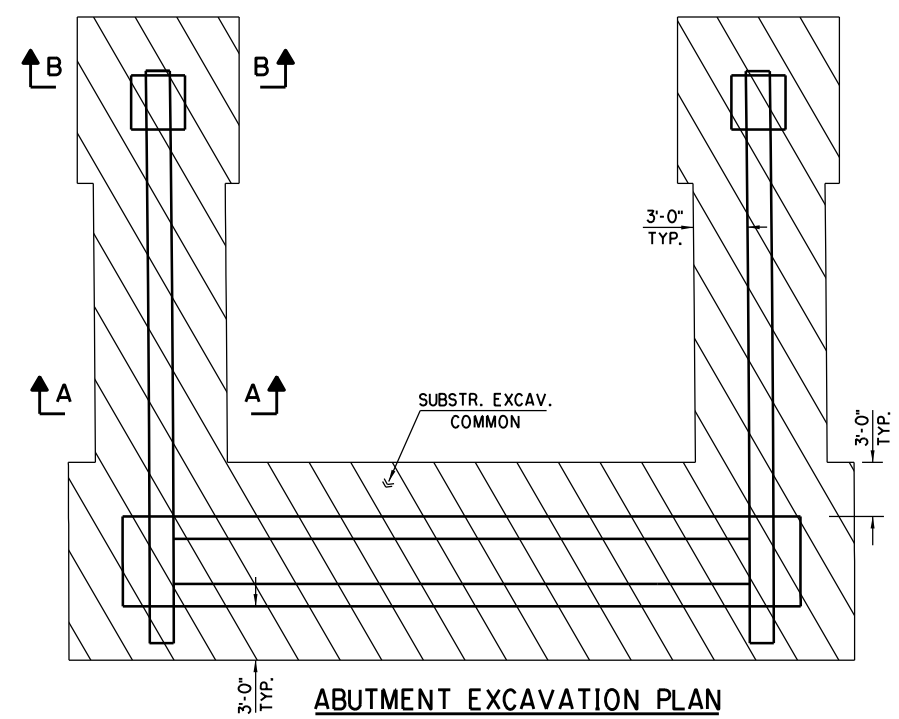
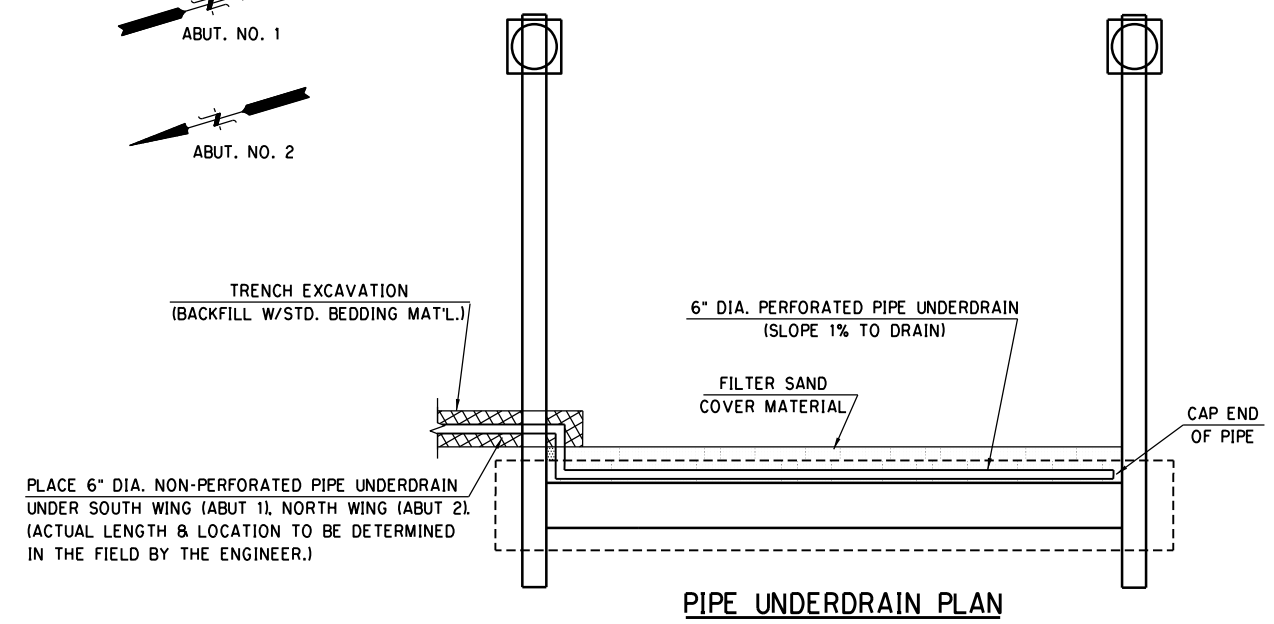
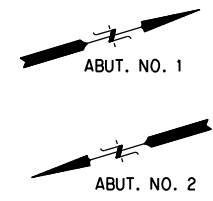

① VARIES FOR ABUT. NO. 1.

ABUTMENT EXCAVATION DETAILS

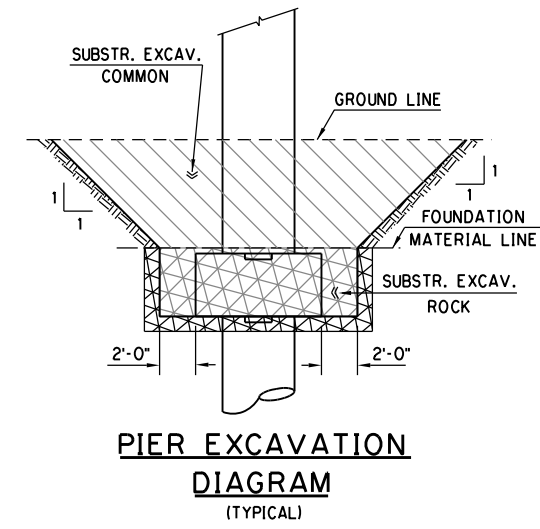
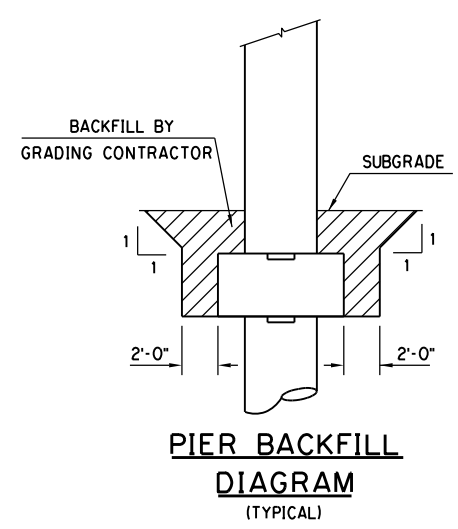
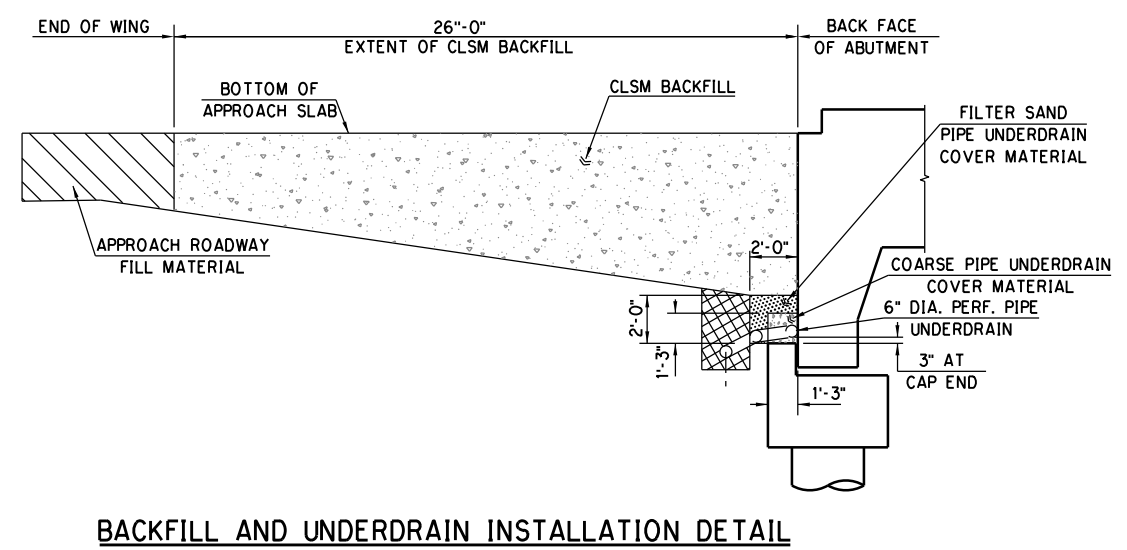

ABUTMENT UNDERDRAIN DETAILS

CONSTRUCTION NOTES:

1. CLSM BACKFILL SHALL NOT BE PLACED UNTIL THE SUPERSTRUCTURE IS IN PLACE AND THE ABUTMENT WING CONCRETE HAS ATTAINED A STRENGTH OF 3000 P.S.I.
2. INSTALLATION OF THE PIPE UNDERDRAIN SHALL BE AS SHOWN IN THE PLANS AND ON ODOT STD. PUD-4 AND SPI-5. THE EXTENT, LOCATION AND DEPTH OF THE 6" NON-PERFORATED PIPE UNDERDRAIN WILL BE DETERMINED BY THE ENGINEER TO SUIT CONDITIONS FOUND DURING CONSTRUCTION.
3. COST OF ALL MATERIALS, EQUIPMENT, LABOR, AND INCIDENTALS NEEDED FOR THE INSTALLATION OF UNDERDRAIN PIPE SHALL BE INCLUDED IN THE UNIT PRICE BID FOR "6" PERFORATED PIPE UNDERDRAIN ROUND" AND "6" NON-PERF. PIPE UNDERDRAIN RND."
4. FOR ADDITIONAL DETAILS FOR PIPE UNDERDRAIN INSTALLATION SEE ODOT STDS. PUD-4 AND SPI-5.

PHASE 4		OKLAHOMA COUNTY	
BRIDGE "L"		RAMP "L" OVER RAMP "A"	
DESIGN		<p>EXCAVATION DIAGRAMS AND UNDERDRAIN DETAILS</p> <p>STATE JOB NO. 09032(08) SHEET NO. B136</p>	
DRAWN			
CHECKED			
APPROVED			
SQUAD	POE		

3/1/2024 10:35:33 AM
 H:\PROJECTS\2789_CrossRoads\Phase_4\Bridges\Drawings\Ph4 Bridges\Bridges L\0903208 P4 Br L Excav.dgn

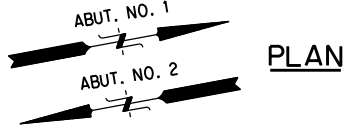
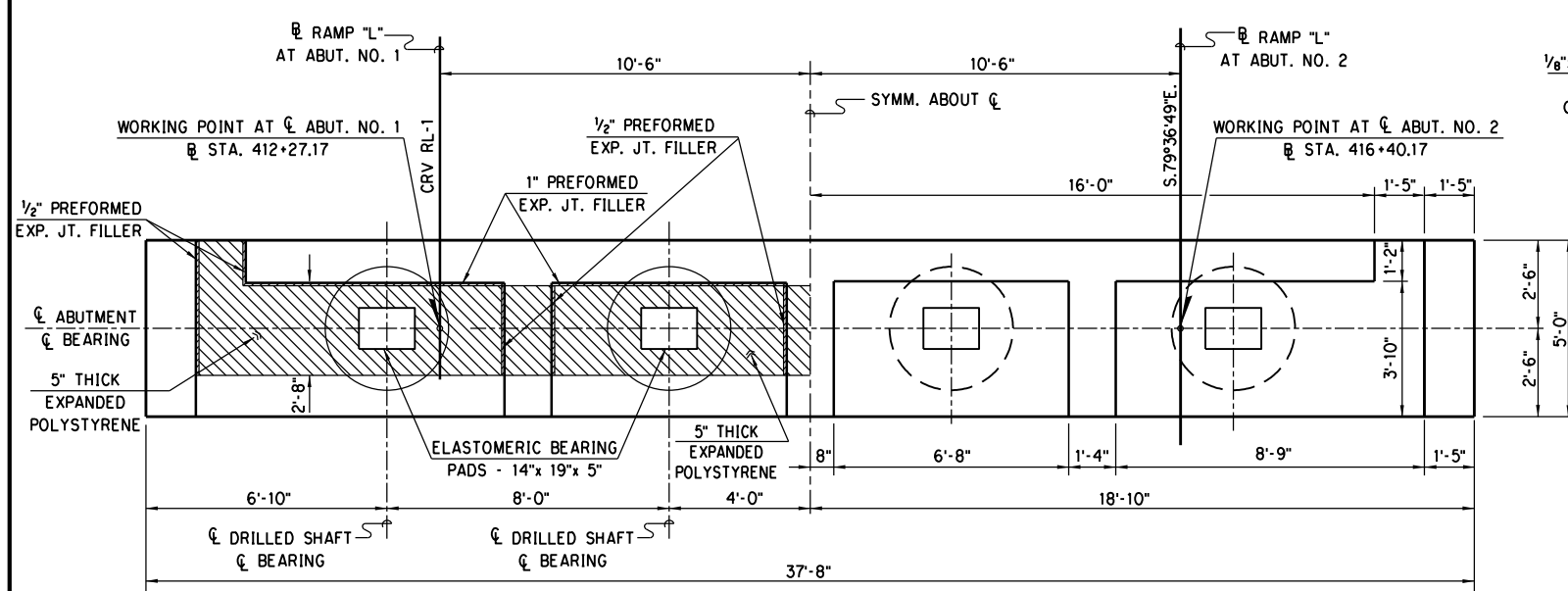

PLAN

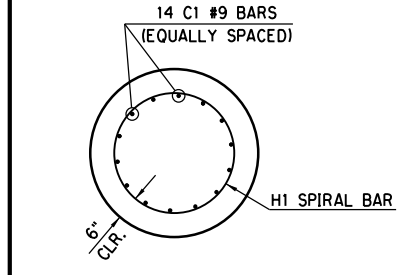

SECTION B-B

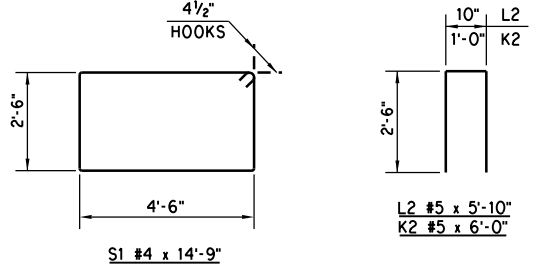

ELEVATION

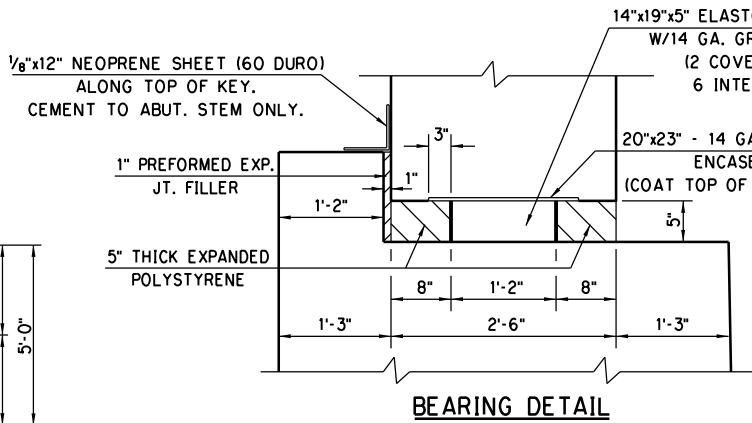
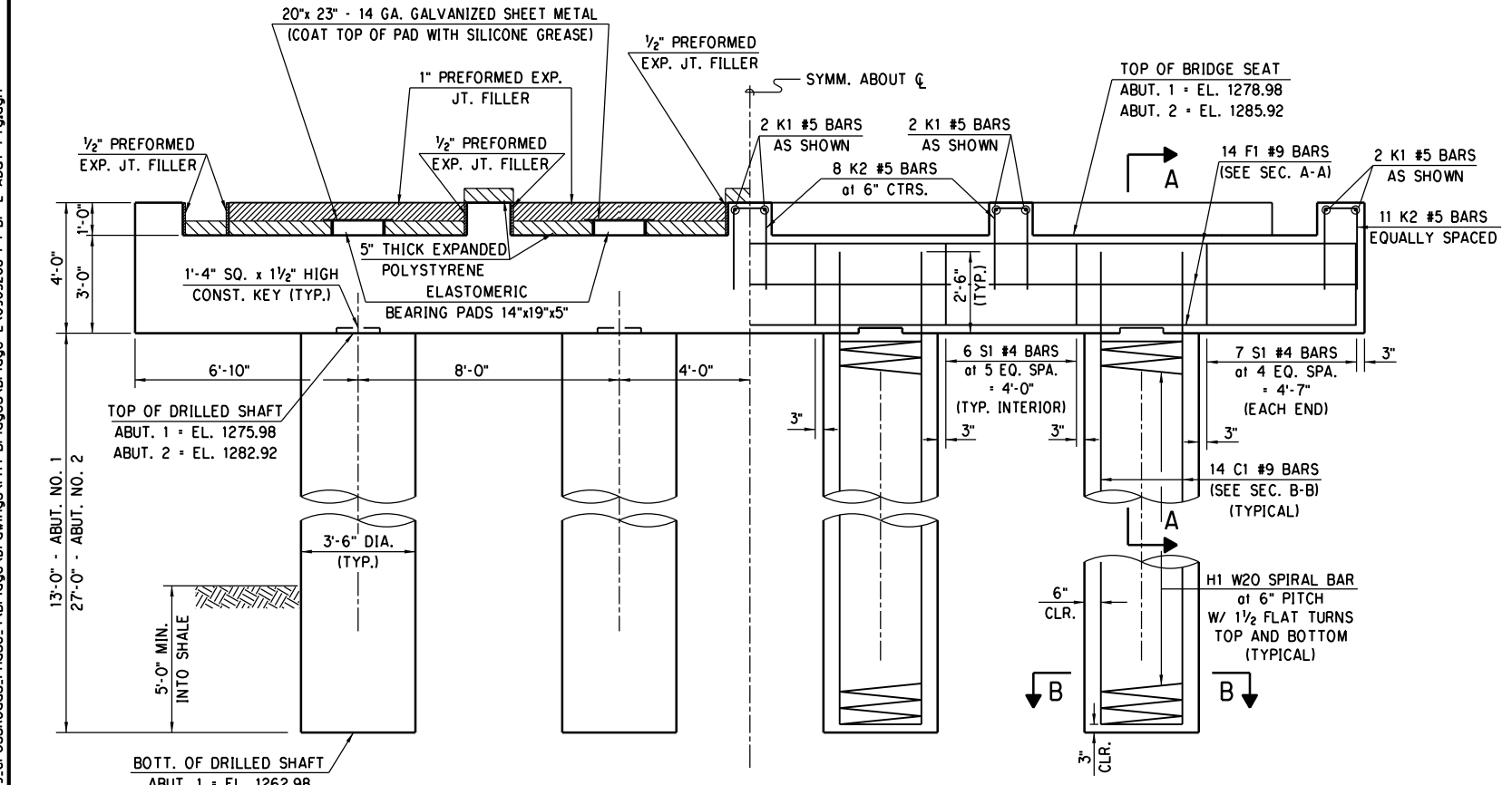

BEARING DETAIL

NOTE: ALL COST OF POLYSTYRENE, NEOPRENE SHEET, EXPANSION JOINT FILLER, GALVANIZED SHEET METAL AND SILICONE GREASE TO BE INCLUDED IN THE PRICE BID FOR OTHER ITEMS OF WORK.

ABUTMENT FOOTING QUANTITIES			
ITEM	UNIT	ABUT. NO. 1	ABUT. NO. 2
SUBSTR. EXCAVATION COMMON	C.Y.	66.00	66.00
CLASS A CONCRETE	C.Y.	22.20	22.20
ELASTOMERIC BEARING PAD	EA.	4.00	4.00
REINFORCING STEEL	LB.	2,850.00	2,850.00
DRILLED SHAFTS 42" DIAMETER	L.F.	52.00	108.00

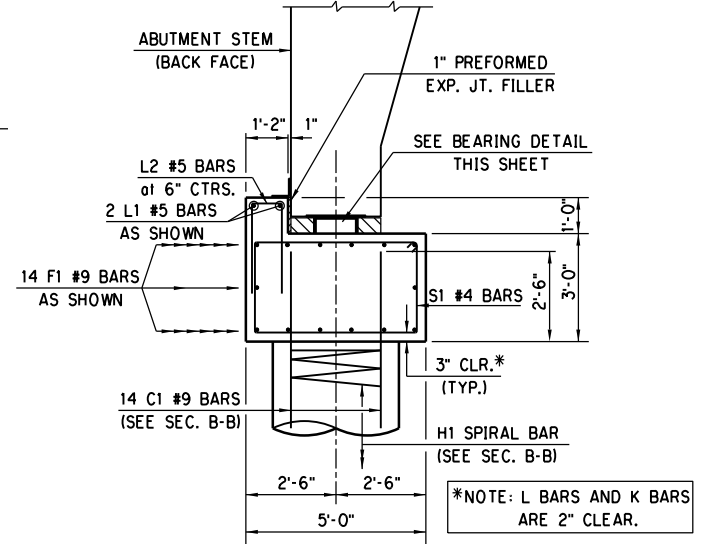

SECTION A-A

NOTE: FOR EXCAVATION DIAGRAM AND UNDERDRAIN DETAILS, SEE "SUBSTRUCTURE EXCAVATION AND PIPE UNDERDRAIN DETAILS" SHEET.

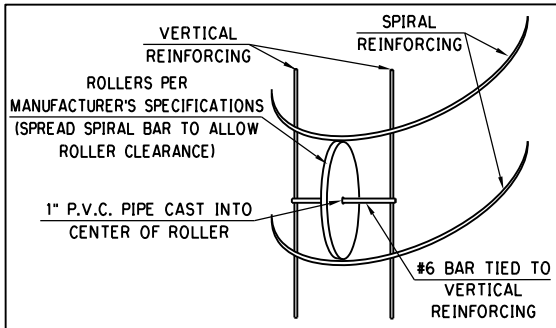

ROLLER INSTALLATION DETAIL

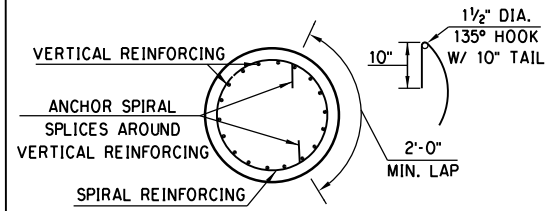

SPIRAL REINFORCING SPLICE DETAILS

NOTE: SPIRAL BARS SHALL CONFORM TO AASHTO M-32. SPIRAL BAR LENGTHS DO NOT INCLUDE LAP. IF LAP IS REQUIRED, THE LENGTH OF THE LAP SHALL BE AS SHOWN.

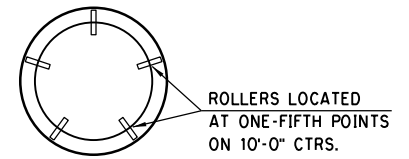

ROLLER PLACEMENT

ROLLER DETAILS

NOTE: REINFORCING CAGE CENTERING DEVICES SHALL CONSIST OF ROLLERS PLACED AT SPACING AS SHOWN AND HAVE THE CHARACTERISTICS AS INDICATED IN THE MANUFACTURER'S SPECIFICATIONS. SLAB BOLSTERS AND HIGH CHAIRS WILL BE ALLOWED BY THE DEPARTMENT.

BAR LIST - ONE FOOTING					
MARK	NO.	SIZE	FORM	SPACING	LENGTH
F1	14	#9	STR.	AS SHOWN	37'-2"
K1	10	#5	STR.	AS SHOWN	4'-8"
K2	46	#5	BNT.	AS SHOWN	6'-0"
L1	2	#5	STR.	AS SHOWN	31'-8"
L2	59	#5	BNT.	6" C/C	5'-10"
S1	32	#4	BNT.	AS SHOWN	14'-9"

BAR LIST - 40" DRILLED SHAFT					
MARK	NO.	SIZE	FORM	SPACING	LENGTH
C1	56	9	STR.	AS SHOWN	①
H1	4	W-20	SPIRAL	6" PITCH	①

① LENGTH:
C1 - ABUT. NO. 1 = 15'-3"
ABUT. NO. 2 = 29'-3"

**H1 - ABUT. NO. 1 = 223'-4"
ABUT. NO. 2 = 443'-8"

** LENGTH SHOWN DOES NOT INCLUDE ANY LAPS FOR SPLICES. CONTRACTOR MAY ADD SPLICES AS NECESSARY, BUT PAYMENT WILL NOT BE MADE FOR EXTRA LENGTH REQUIRED. ADD 3'-8" FOR EACH SPLICE.

DESIGN		PHASE 4	OKLAHOMA COUNTY
DRAWN		BRIDGE "L"	RAMP "L" OVER RAMP "A"
CHECKED		ABUTMENT FOOTING DETAILS	
APPROVED			
SQUAD	POE		
		STATE JOB NO. 09032(08)	SHEET NO. B137

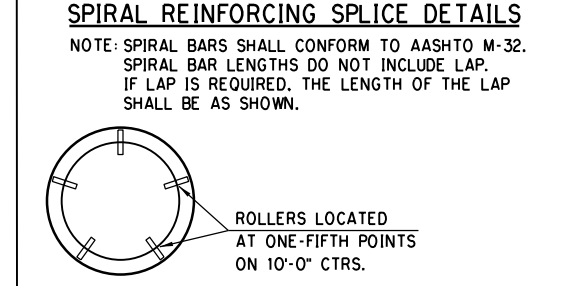
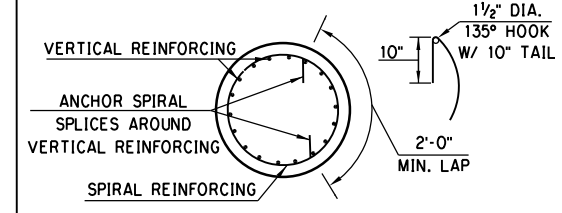
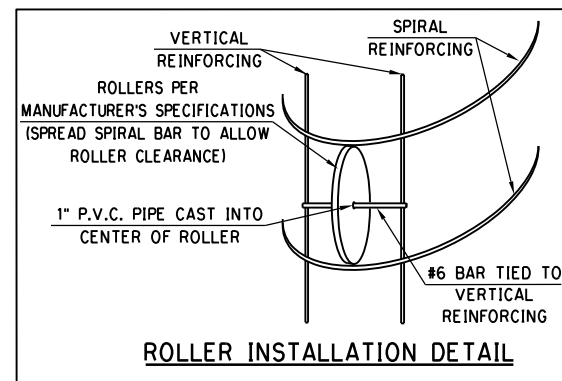
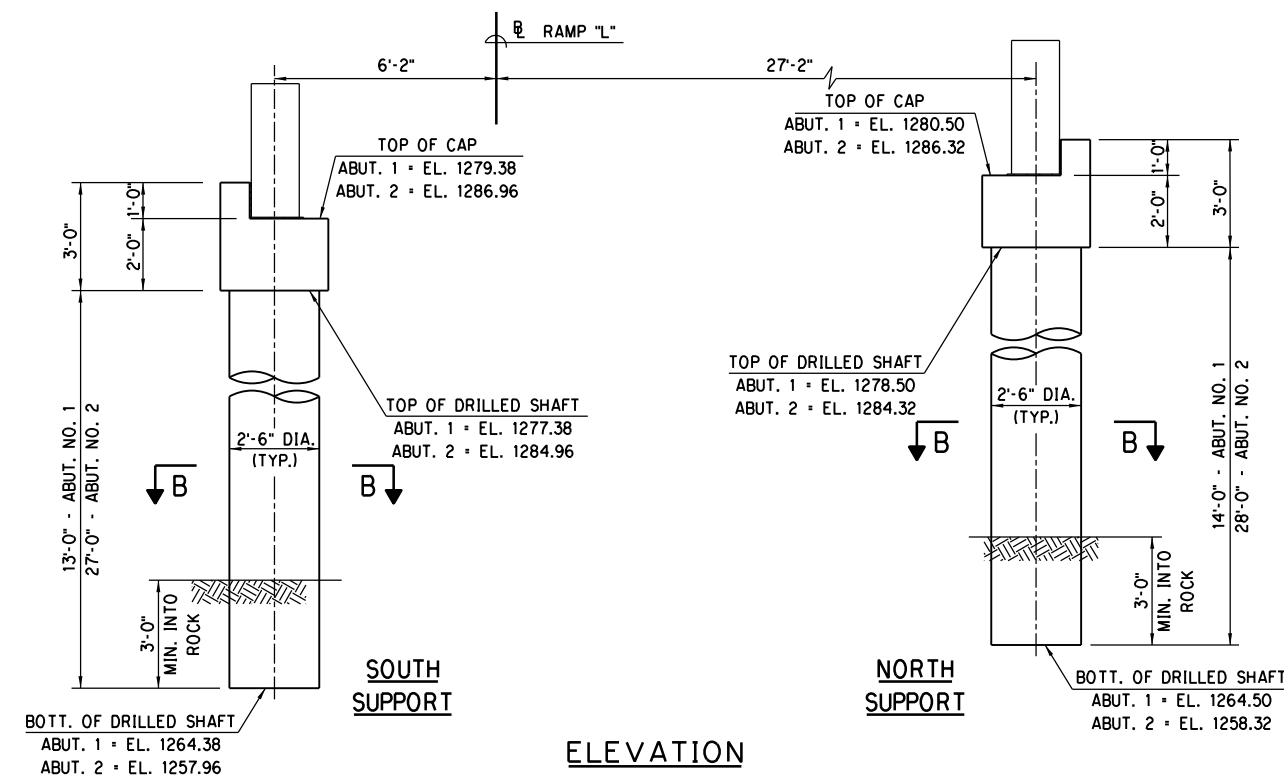
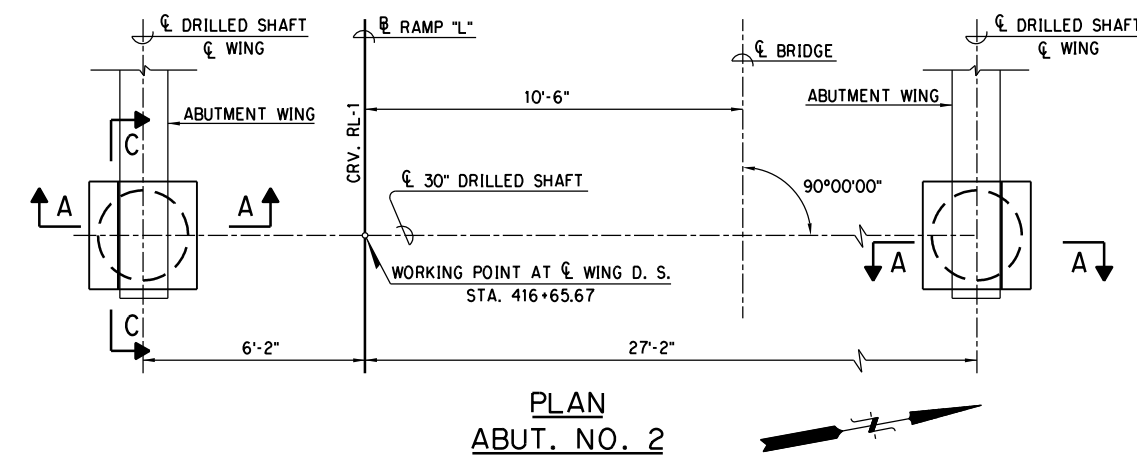
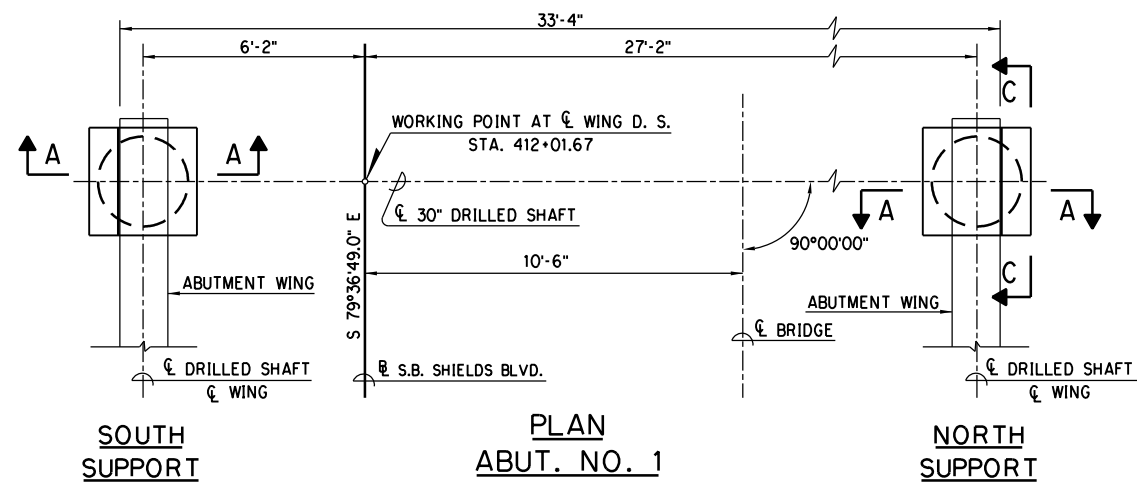

ROLLER DETAILS
NOTE: REINFORCING CAGE CENTERING DEVICES SHALL CONSIST OF ROLLERS PLACED AT SPACING AS SHOWN AND HAVE THE CHARACTERISTICS AS INDICATED IN THE MANUFACTURER'S SPECIFICATIONS. SLAB BOLSTERS AND HIGH CHAIRS WILL BE ALLOWED BY THE DEPARTMENT.

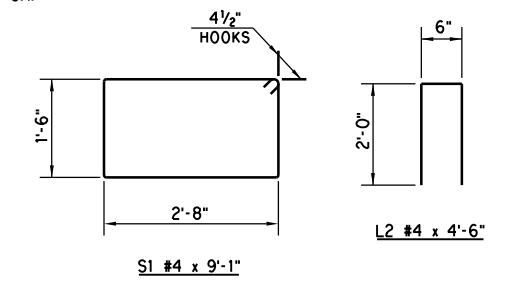
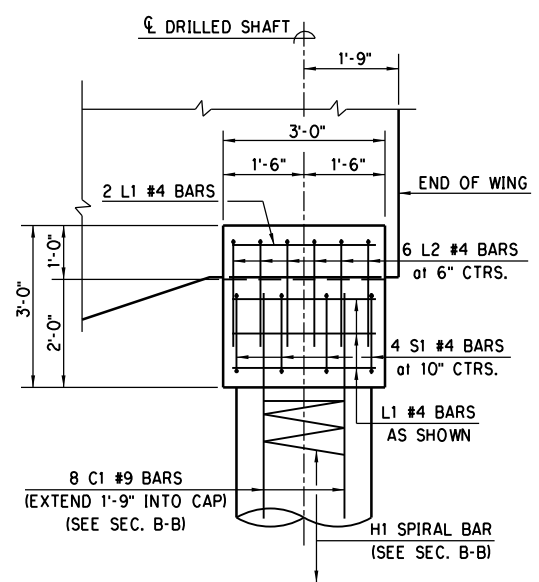
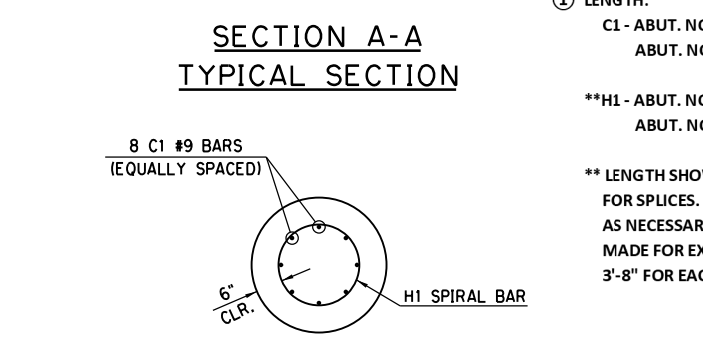
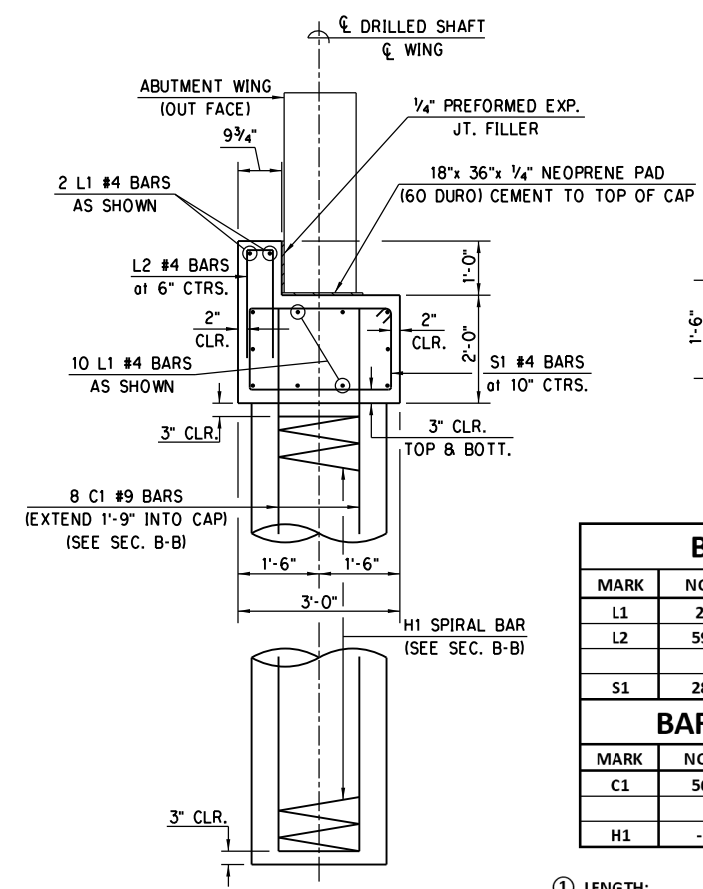

BAR LIST - ONE FOOTING

MARK	NO.	SIZE	FORM	SPACING	LENGTH
L1	2	#5	STR.	AS SHOWN	2'-8"
L2	59	#5	BNT.	6" C/C	4'-6"
S1	28	#4	BNT.	AS SHOWN	9'-1"

BAR LIST - 30" DRILLED SHAFT

MARK	NO.	SIZE	FORM	SPACING	LENGTH
C1	56	#9	STR.	AS SHOWN	①
H1	-	W-20	SPIRAL	6" PITCH	①

① LENGTH:

	SOUTH	NORTH
C1 - ABUT. NO. 1 =	14'-6"	15'-6"
ABUT. NO. 2 =	28'-6"	27'-6"
**H1 - ABUT. NO. 1 =	134'-4"	143'-9"
ABUT. NO. 2 =	267'-0"	257'-6"

** LENGTH SHOWN DOES NOT INCLUDE ANY LAPS FOR SPLICES. CONTRACTOR MAY ADD SPLICES AS NECESSARY, BUT PAYMENT WILL NOT BE MADE FOR EXTRA LENGTH REQUIRED. ADD 3'-8" FOR EACH SPLICE.

WING SUPPORT QUANTITIES

ITEM	UNIT	ABUT. NO. 1	ABUT. NO. 2
SUBSTR. EXCAVATION COMMON	C.Y.	19.00	19.00
CLASS A CONCRETE	C.Y.	1.60	1.60
REINFORCING STEEL	LB.	128.00	128.00
DRILLED SHAFTS 30" DIAMETER	L.F.	27.00	53.00

NOTE: ALL COST OF NEOPRENE PADS AND EXPANSION JOINT FILLER TO BE INCLUDED IN THE PRICE BID FOR OTHER ITEMS OF WORK.

NOTE: FOR EXCAVATION DIAGRAM, SEE "SUBSTRUCTURE EXCAVATION AND PIPE UNDERDRAIN DETAILS" SHEET

PHASE 4 OKLAHOMA COUNTY
BRIDGE "L" RAMP "L" OVER RAMP "A"

ABUTMENT WING SUPPORT DETAILS

STATE JOB NO. 09032(08) SHEET NO. B138

DESIGN	
DRAWN	
CHECKED	
APPROVED	
SQUAD	POE

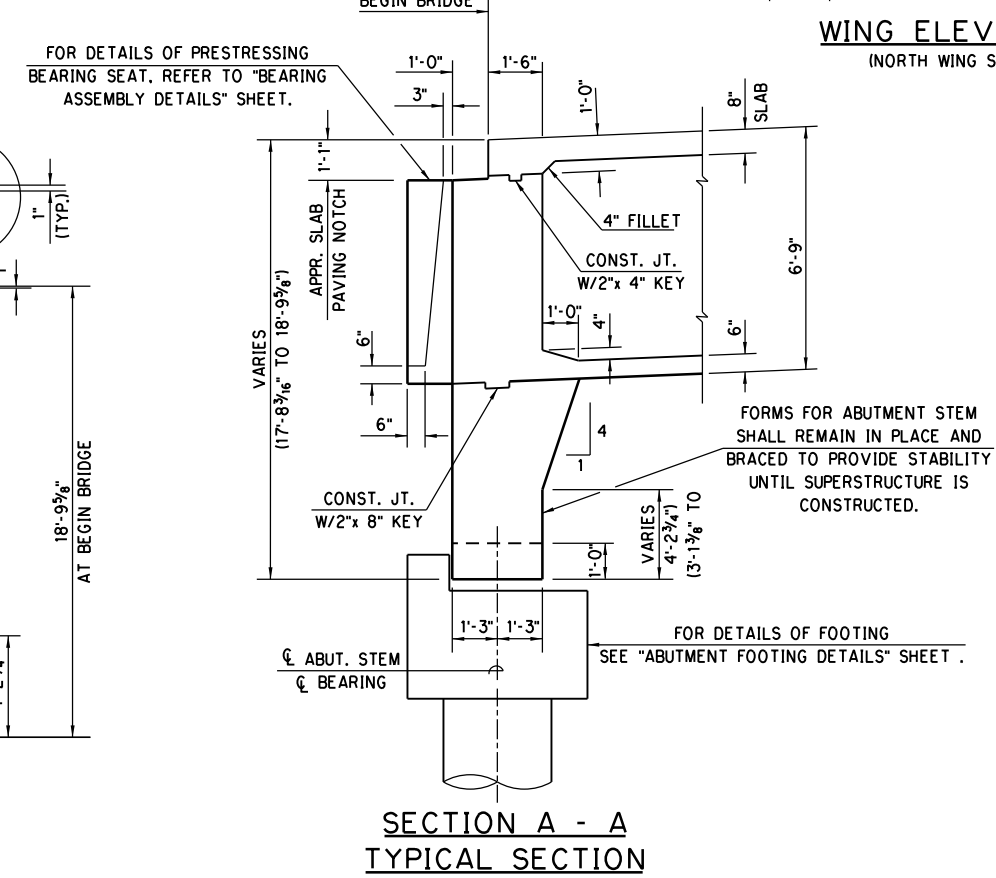
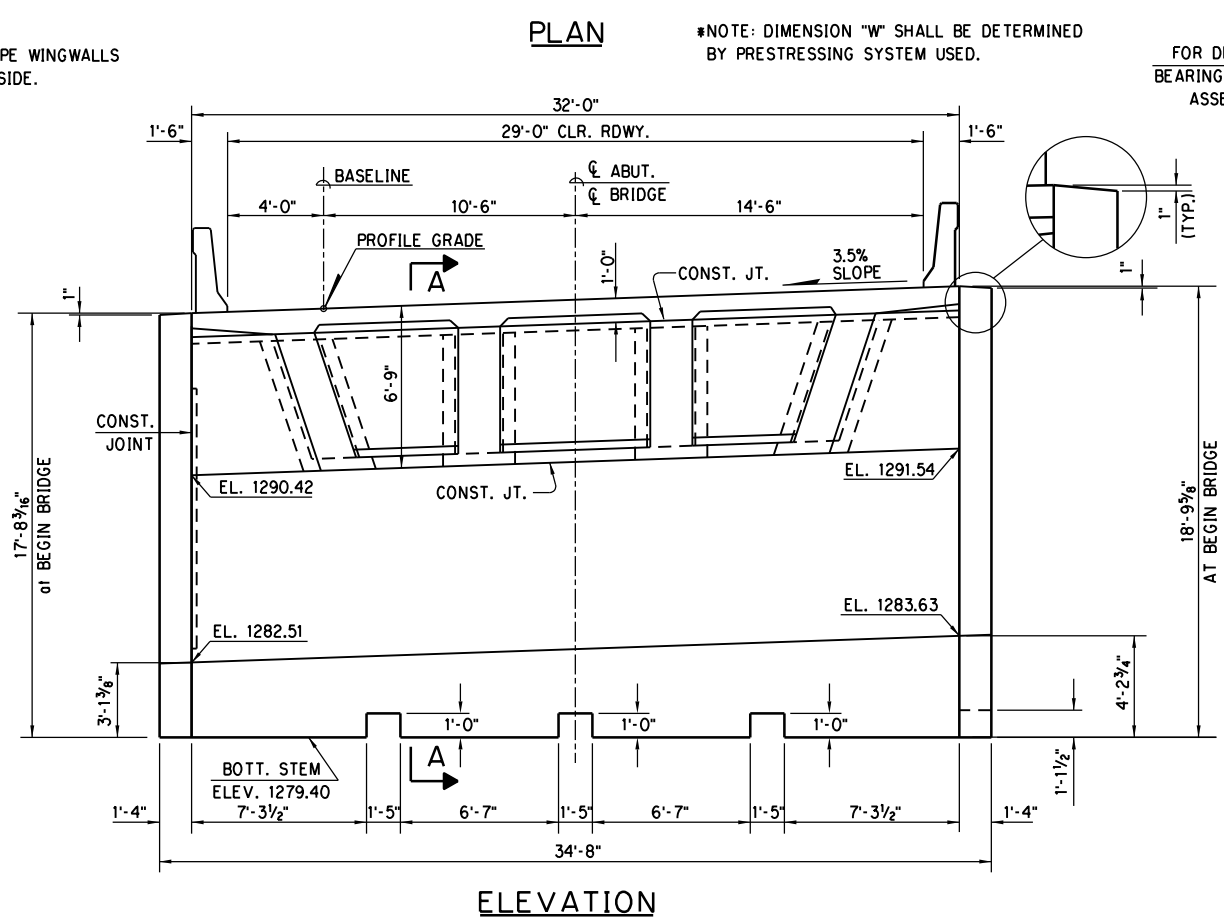
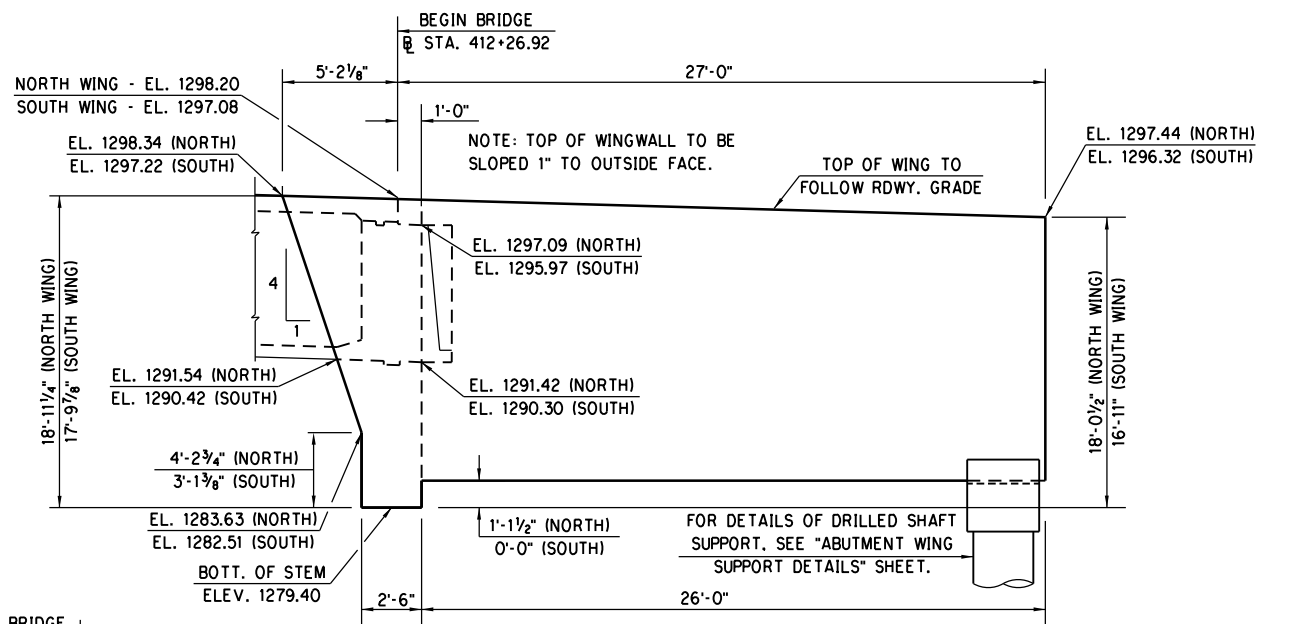
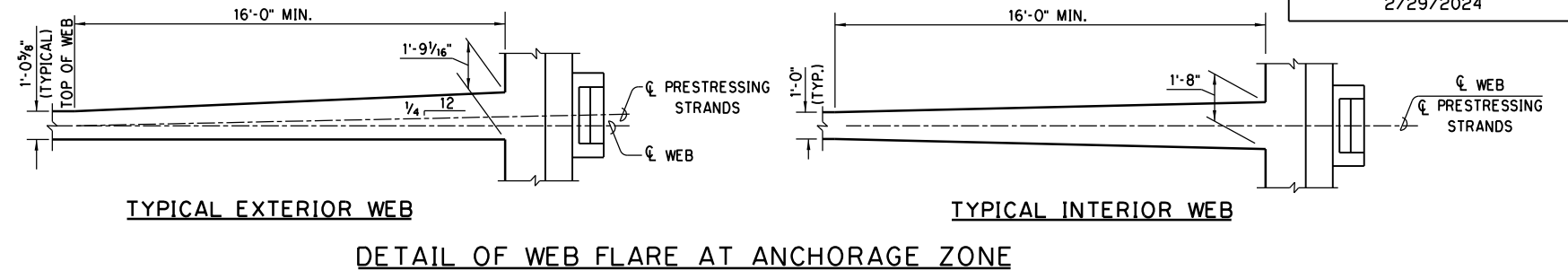
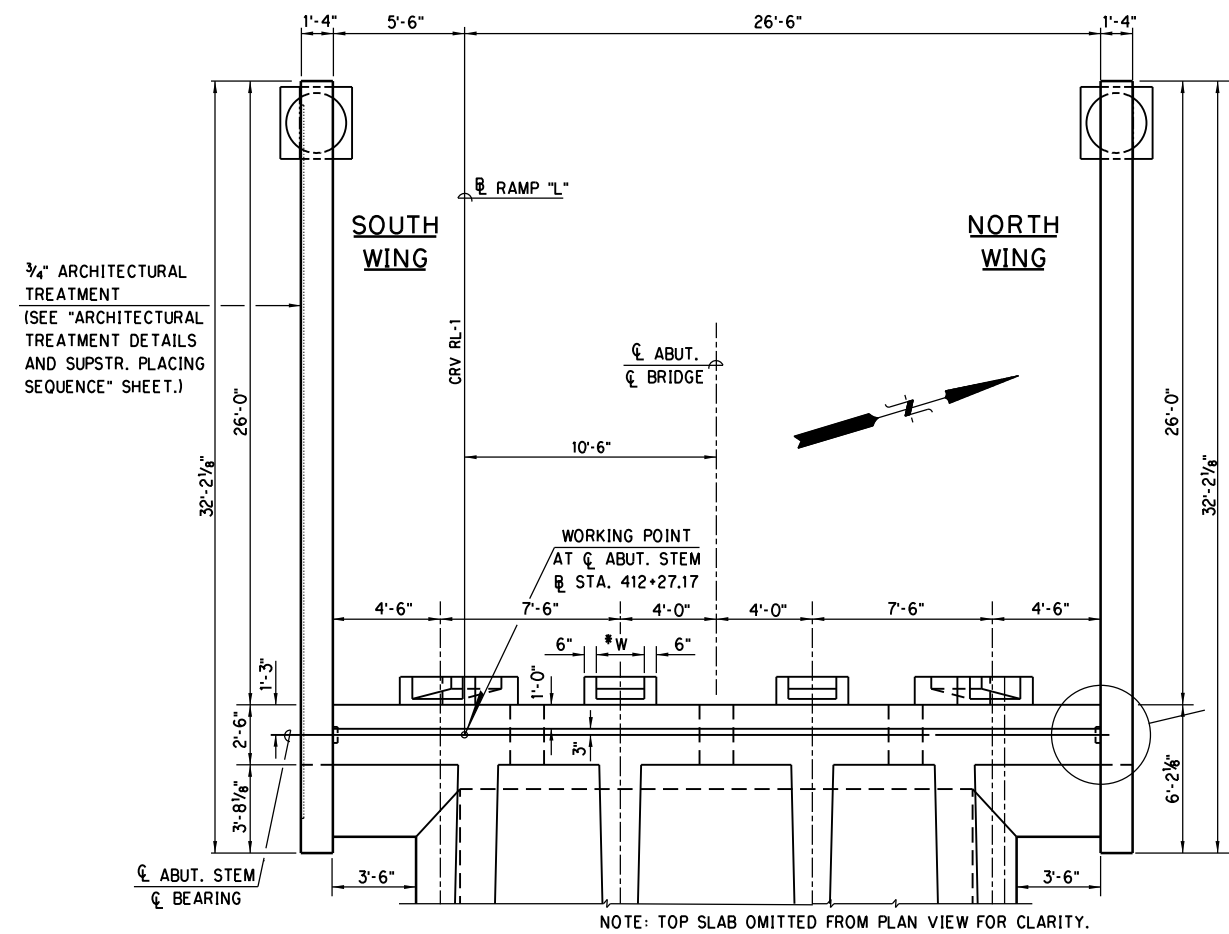

ABUT. QUANTITIES - TWO WINGS

ITEM	UNIT	TOTAL
SUBSTRUCTURE EXCAVATION COMMON	C.Y.	31.00
CLASS AA CONCRETE	C.Y.	51.50
EPOXY COATED REINFORCING STEEL	LB.	7,025.00
CLSM BACKFILL	C.Y.	310.00
6" PERF. PIPE UNDERDRAIN ROUND	L.F.	34.00
6" NON-PERF. PIPE UNDERDRAIN ROUND	LB.	20.00

PHASE 4 OKLAHOMA COUNTY

BRIDGE "L" RAMP "L" OVER RAMP "A"

ABUTMENT DETAILS
ABUTMENT NO. 1
(SHEET 1 OF 3)

STATE JOB NO. 090321081 SHEET NO. B139

DESIGN	
DRAWN	
CHECKED	
APPROVED	
SQUAD	POE

3/1/2024 10:35:39 AM H:\PROJECTS\2789_CrossRoads_Phase 4\Bridges\Drawings\Ph4 Bridges\Bridges\Bridges\10903208 P4 Br L Abut.dgn

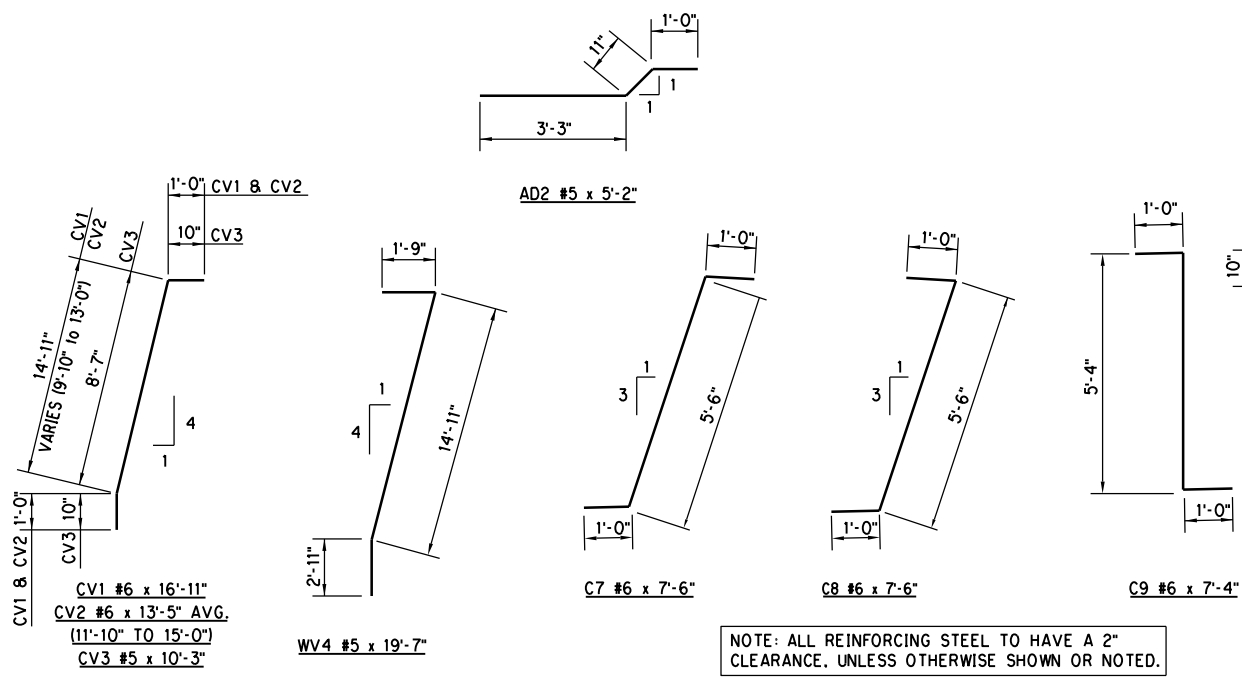
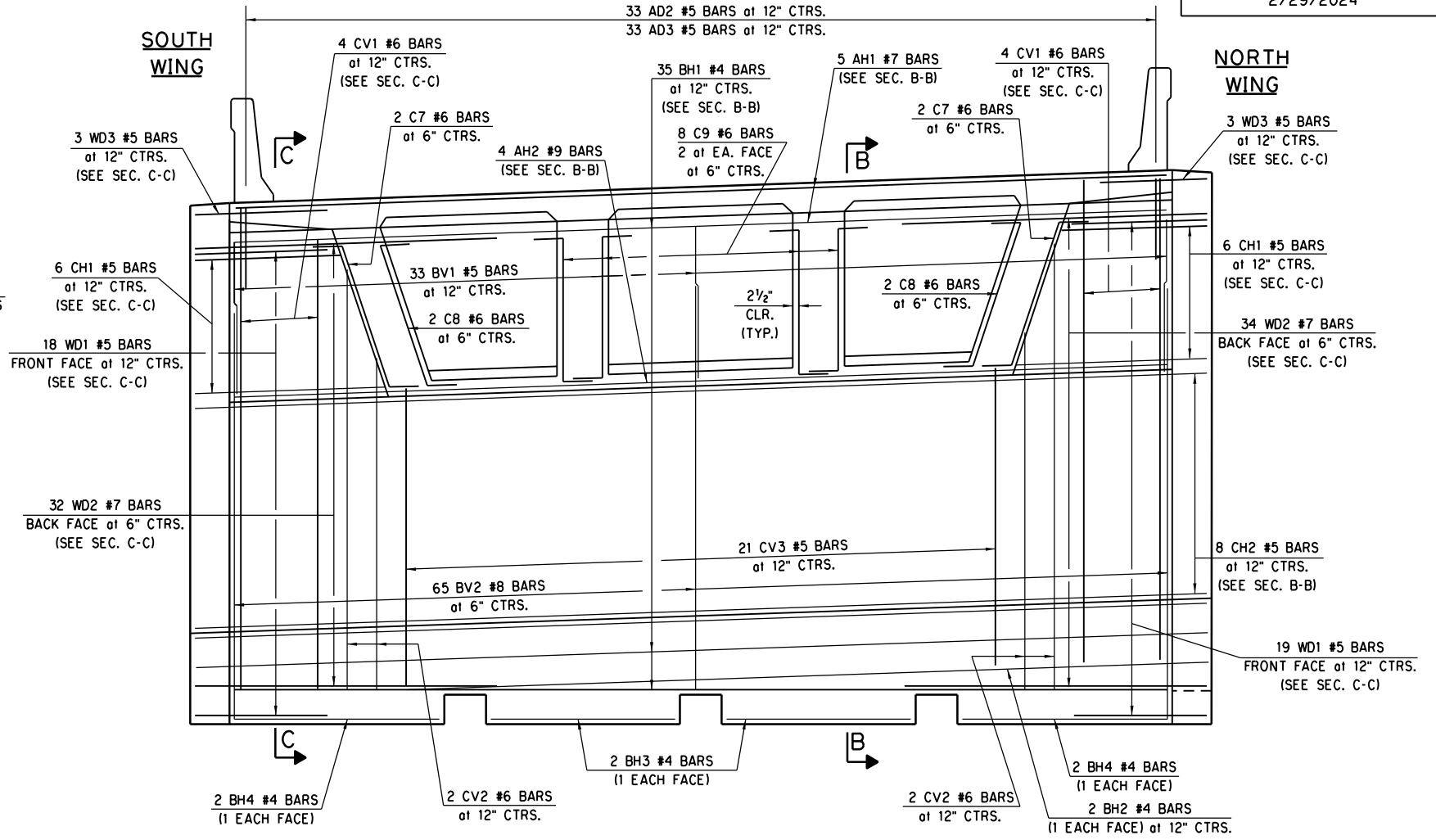
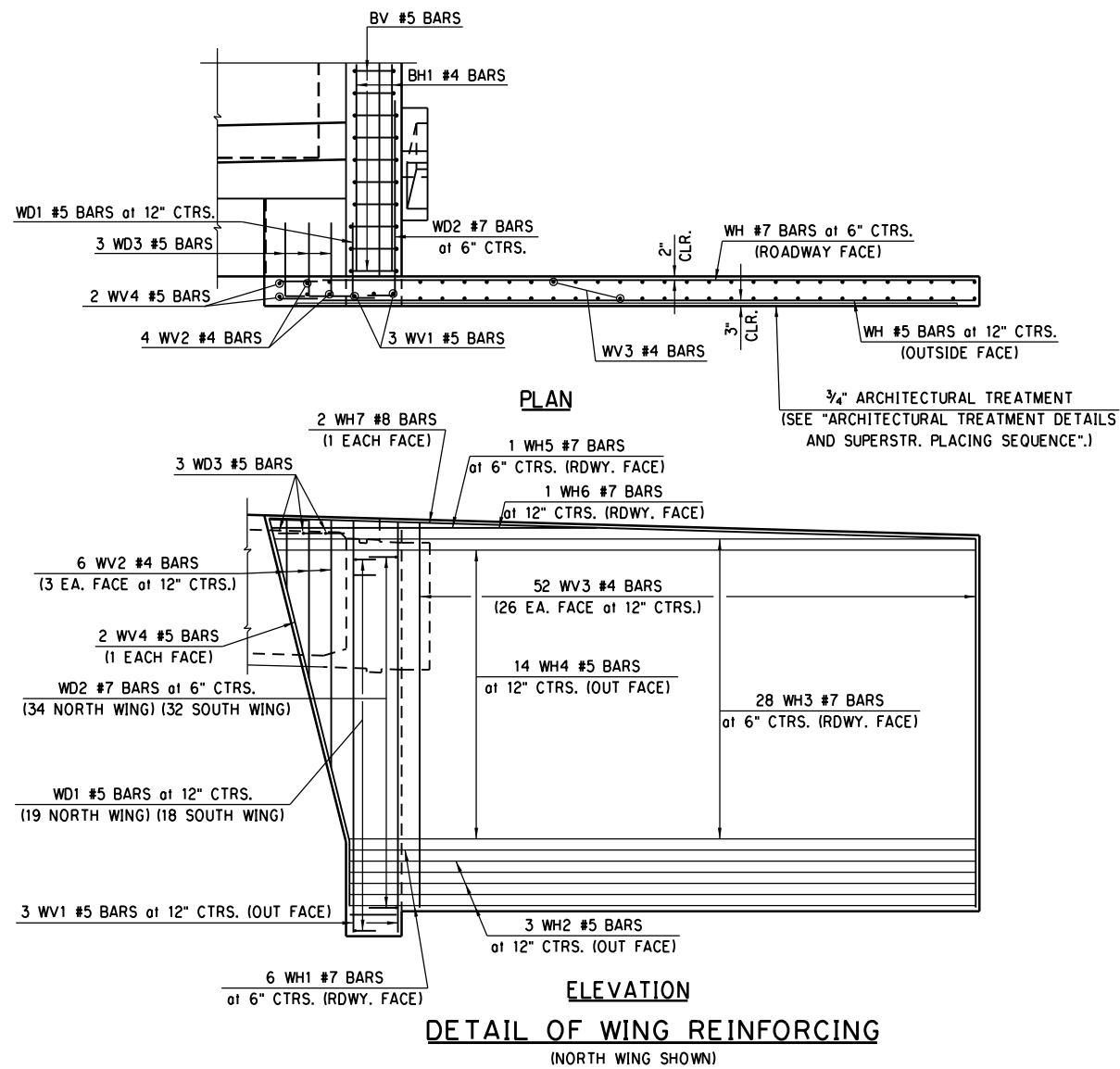

DETAIL OF DIAPHRAGM AND STEM REINFORCING
NOTE: FOR SECTIONS B-B AND C-C, SEE SHEET 3 OF 3.

**ABUTMENT NO. 1 BAR LIST - TWO WINGS
(EPOXY COATED)**

MARK	NO.	SIZE	FORM	SPACING	LENGTH	LENGTH VARIATION
WH1	12	#7	STR.	6" C/C	28'-2"	--
WH2	6	#5	STR.	AS SHOWN	28'-2"	--
WH3	56	#7	STR.	6" C/C	29'-11" AVG.	28'-3" TO 31'-7"
WH4	28	#5	STR.	12" C/C	29'-10" AVG.	28'-3" TO 31'-5"
WH5	2	#7	STR.	6" C/C	13'-10"	--
WH6	2	#5	STR.	12" C/C	13'-10"	--
WH7	4	#8	STR.	AS SHOWN	31'-10"	--
WV1	6	#5	STR.	12" C/C	①	--
WV2	12	#4	STR.	12" C/C	7'-10" AVG.	3'-2" TO 11'-2"
WV3	104	#4	STR.	12" C/C	16'-11 1/2" AVG.	16'-7" TO 17'-4"
WV4	4	#5	BNT.	AS SHOWN	19'-7"	--

① LENGTH:
18'-5" - NORTH
17'-4" - SOUTH

NOTE: FOR STEM AND DIAPHRAGM BARLIST, SEE "SUPERSTRUCTURE DETAILS", SHEET 2 OF 5.

DESIGN		PHASE 4	OKLAHOMA COUNTY
DRAWN		BRIDGE "L"	RAMP "L" OVER RAMP "A"
CHECKED		ABUTMENT DETAILS ABUTMENT NO. 1 (SHEET 2 OF 3)	
APPROVED			
SQUAD	POE	STATE JOB NO. 09032108 SHEET NO. B140	

NOTE: TOP SLAB SUPERSTRUCTURE REINFORCING OMITTED FROM SECTION B-B FOR CLARITY.

NOTE: FOR DETAILS OF REINF. IN PRESTRESSING BEARING SEAT, REFER TO "BEARING ASSEMBLY DETAILS" SHEET.

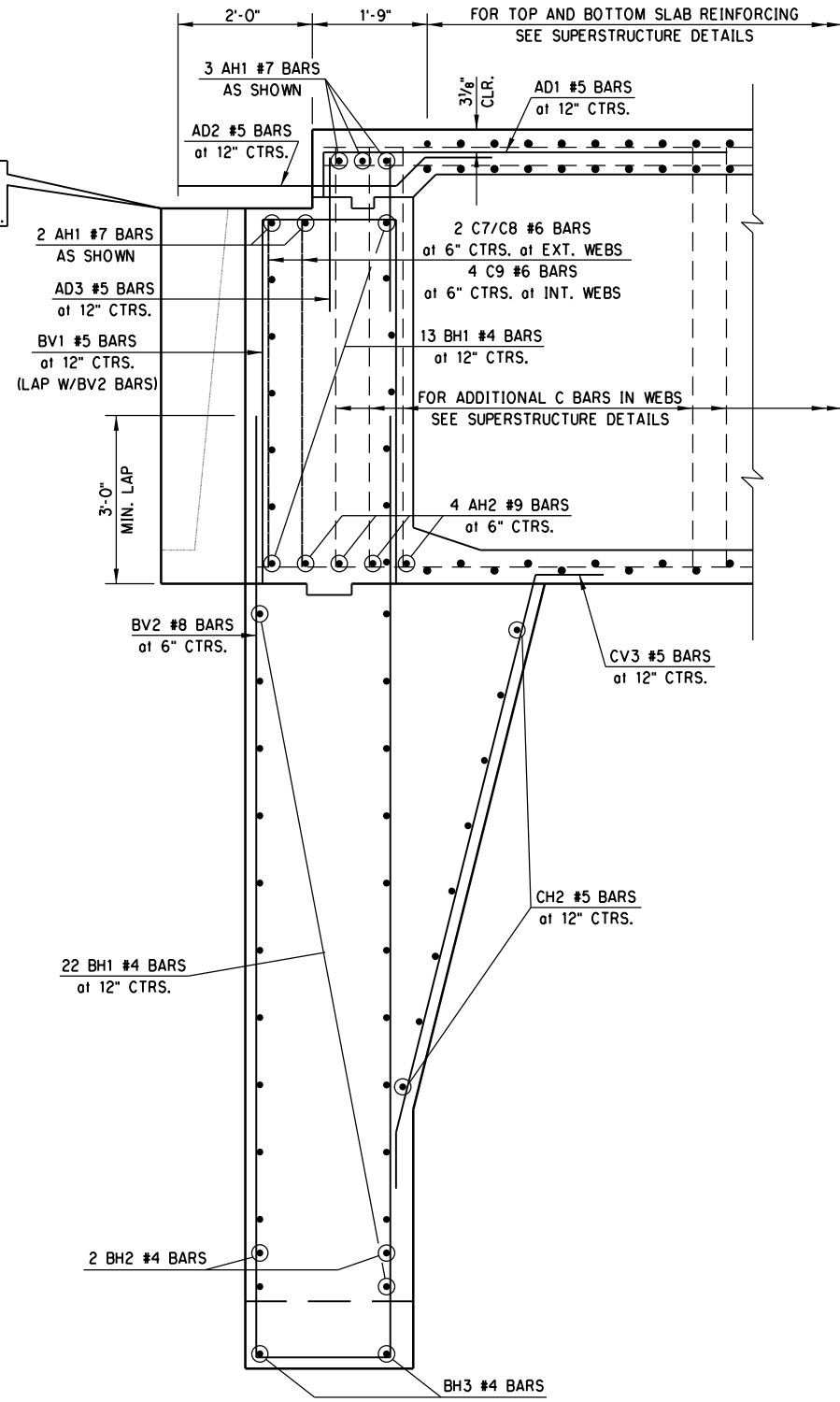

SECTION B-B

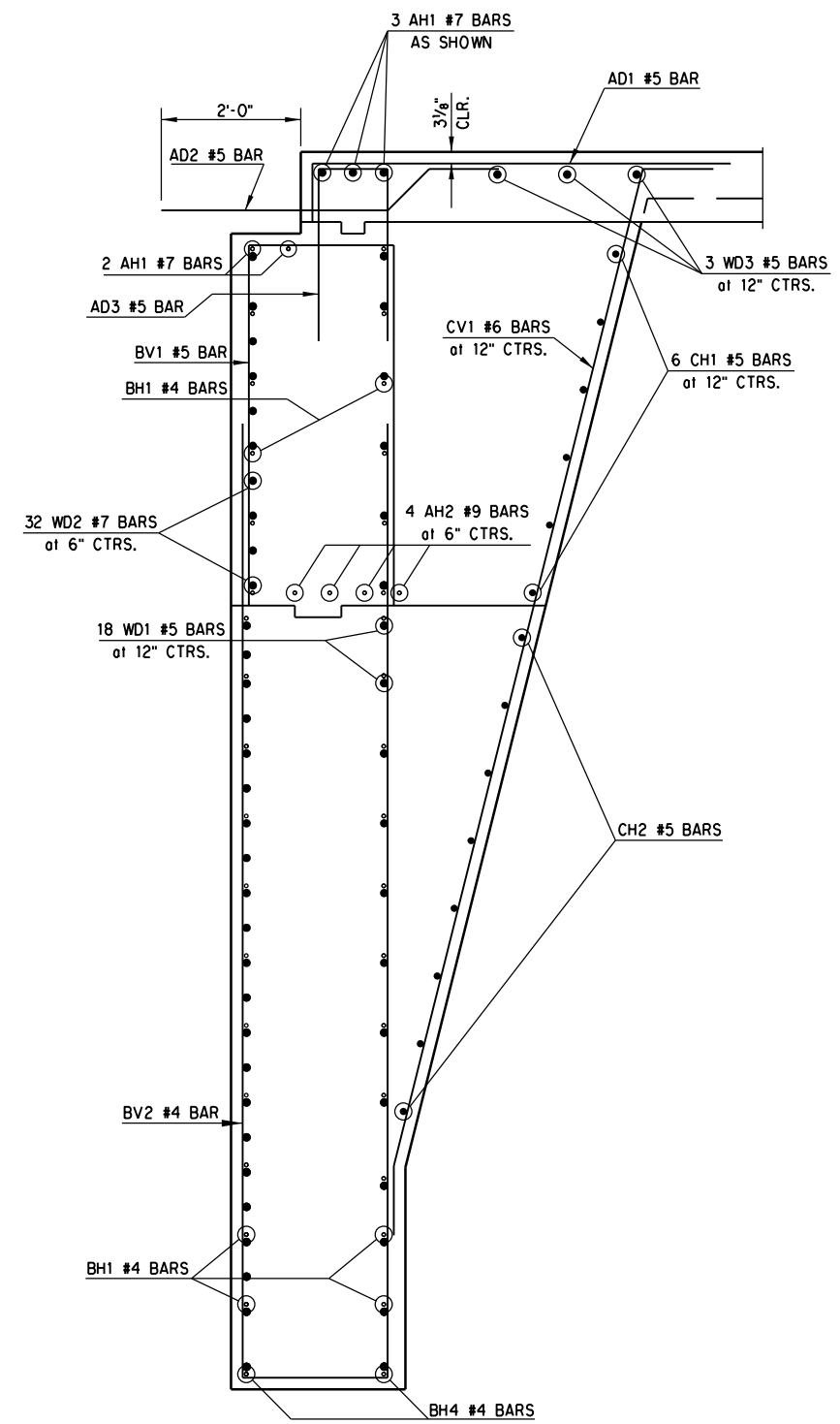

SECTION C-C

3/1/2024 10:35:42 AM H:\PROJECTS\2789_CrossRoads_Phase 4\Bridges\Drawings\Ph4 Bridges\Bridges L\0903208 P4 Br L Abut.dgn

DESIGN		PHASE 4	OKLAHOMA COUNTY
DRAWN		BRIDGE "L"	RAMP "L" OVER RAMP "A"
CHECKED		ABUTMENT DETAILS ABUTMENT NO. 1 (SHEET 3 OF 3)	
APPROVED			
SQUAD	POE	STATE JOB NO. 09032(08)	SHEET NO. B141

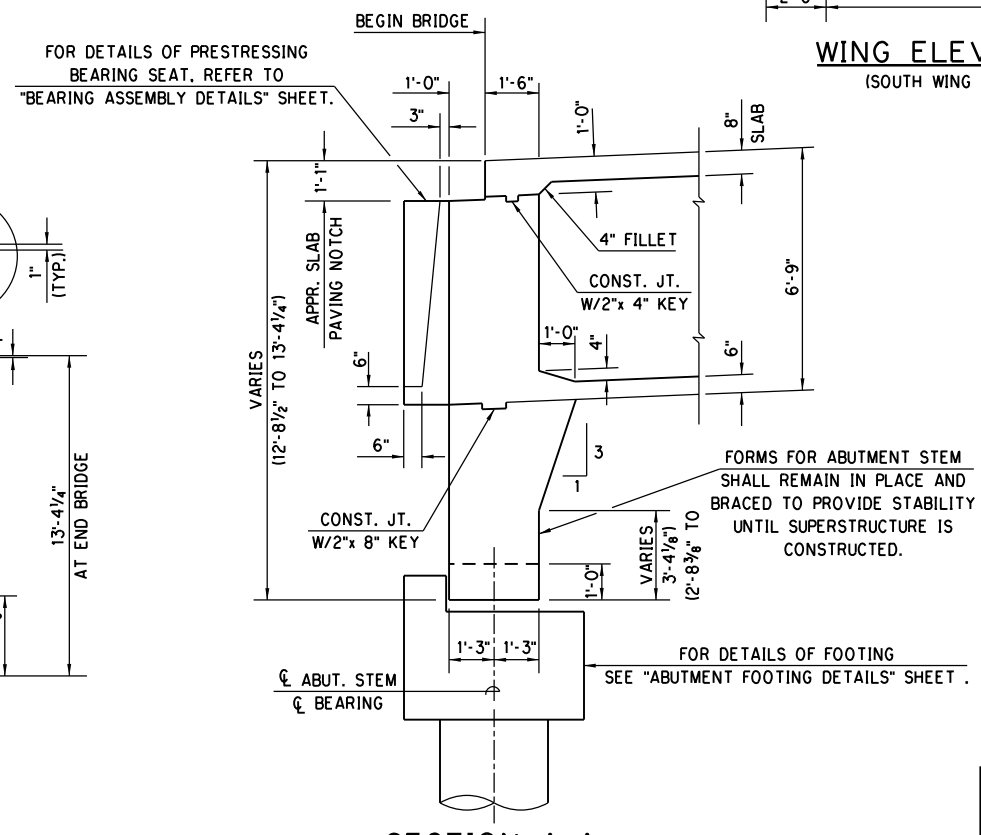
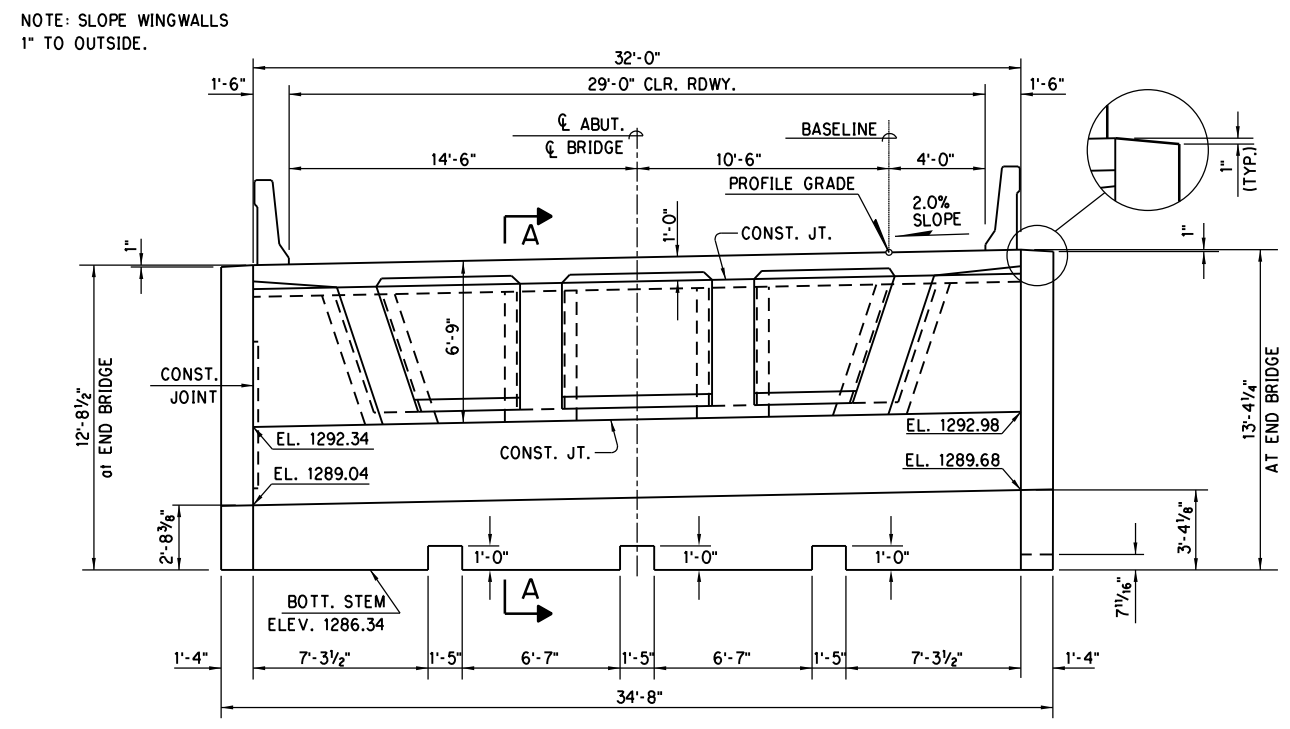
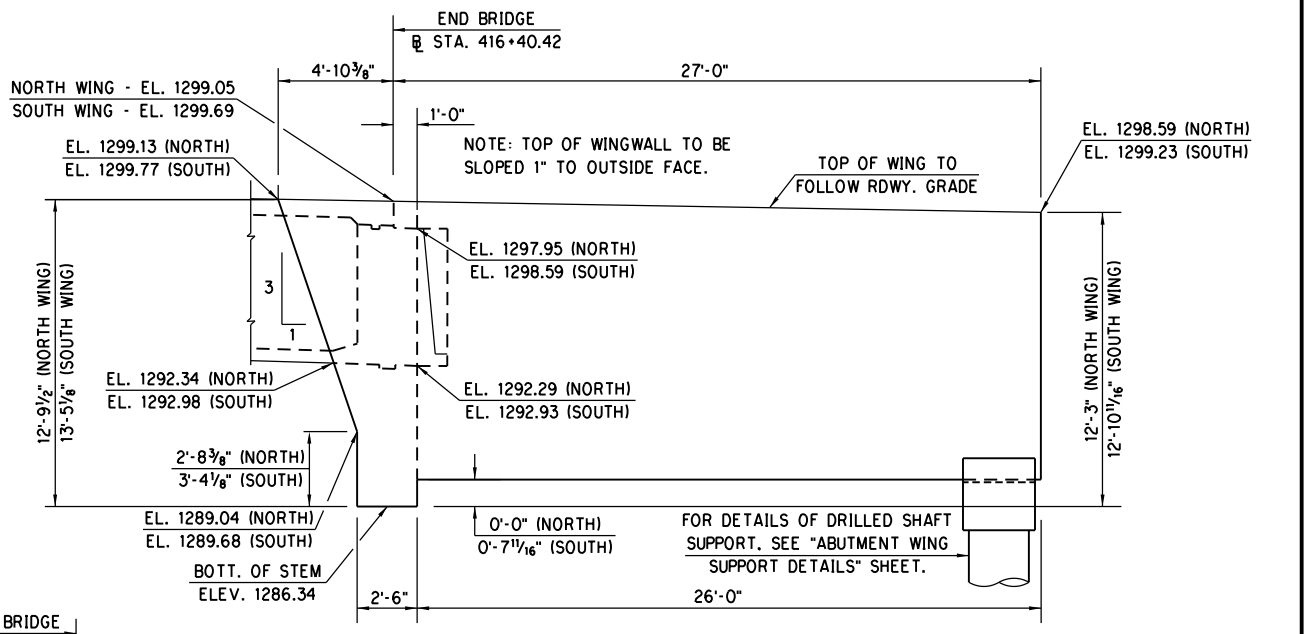
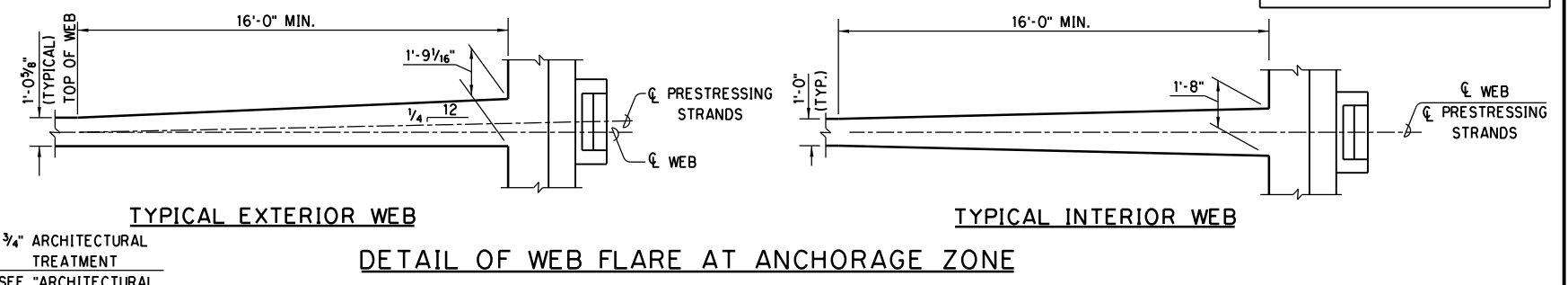
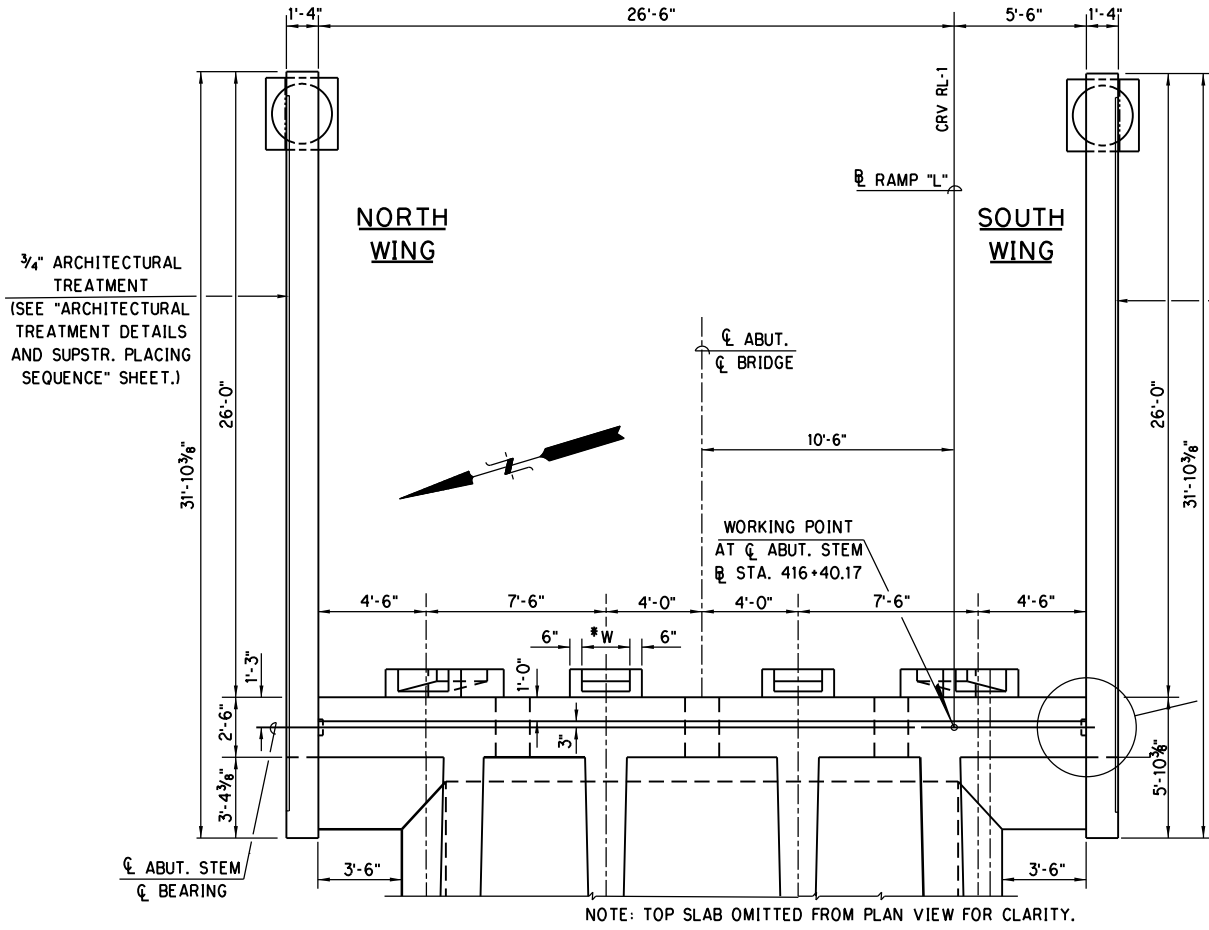

NOTE: ALL DIMENSIONS AND ELEVATIONS SHOWN ARE AT INSIDE (RDWY.) FACE OF WINGS.

NOTE: ADDITIONAL ABUTMENT QUANTITIES ON SHEETS "ABUTMENT FOOTING DETAILS" AND "ABUTMENT WING SUPPORT DETAILS"

NOTE: QUANTITIES FOR ABUTMENT STEM AND DIAPHRAGM ARE INCLUDED IN SUPERSTRUCTURE QUANTITIES.

ABUT. QUANTITIES - TWO WINGS

ITEM	UNIT	TOTAL
SUBSTRUCTURE EXCAVATION COMMON	C.Y.	31.00
CLASS AA CONCRETE	C.Y.	37.30
EPOXY COATED REINFORCING STEEL	LB.	5,140.00
CLSM BACKFILL	C.Y.	310.00
6" PERF. PIPE UNDERDRAIN ROUND	L.F.	34.00
6" NON-PERF. PIPE UNDERDRAIN ROUND	LB.	20.00

PHASE 4 OKLAHOMA COUNTY

BRIDGE "L" RAMP "L" OVER RAMP "A"

ABUTMENT DETAILS
ABUTMENT NO. 2
(SHEET 1 OF 3)

STATE JOB NO. 090321081 SHEET NO. B142

DESIGN	
DRAWN	
CHECKED	
APPROVED	
SQUAD	POE

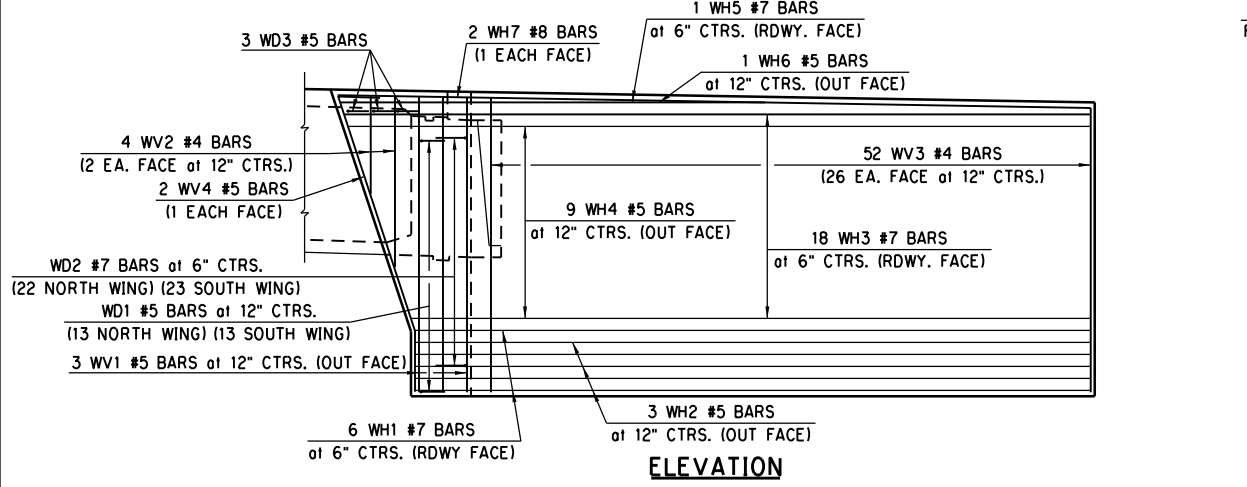
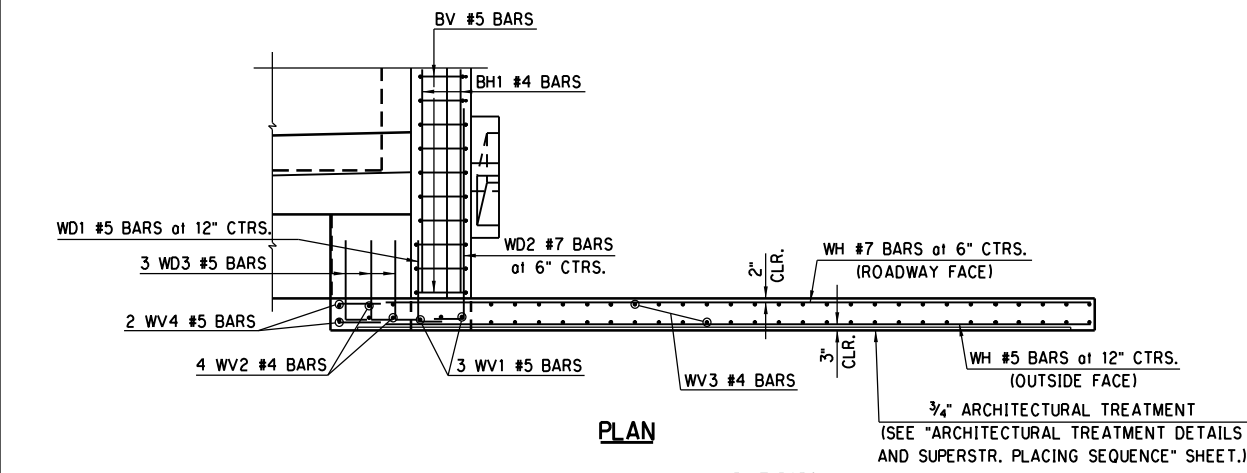

DETAIL OF WING REINFORCING
(NORTH WING SHOWN)

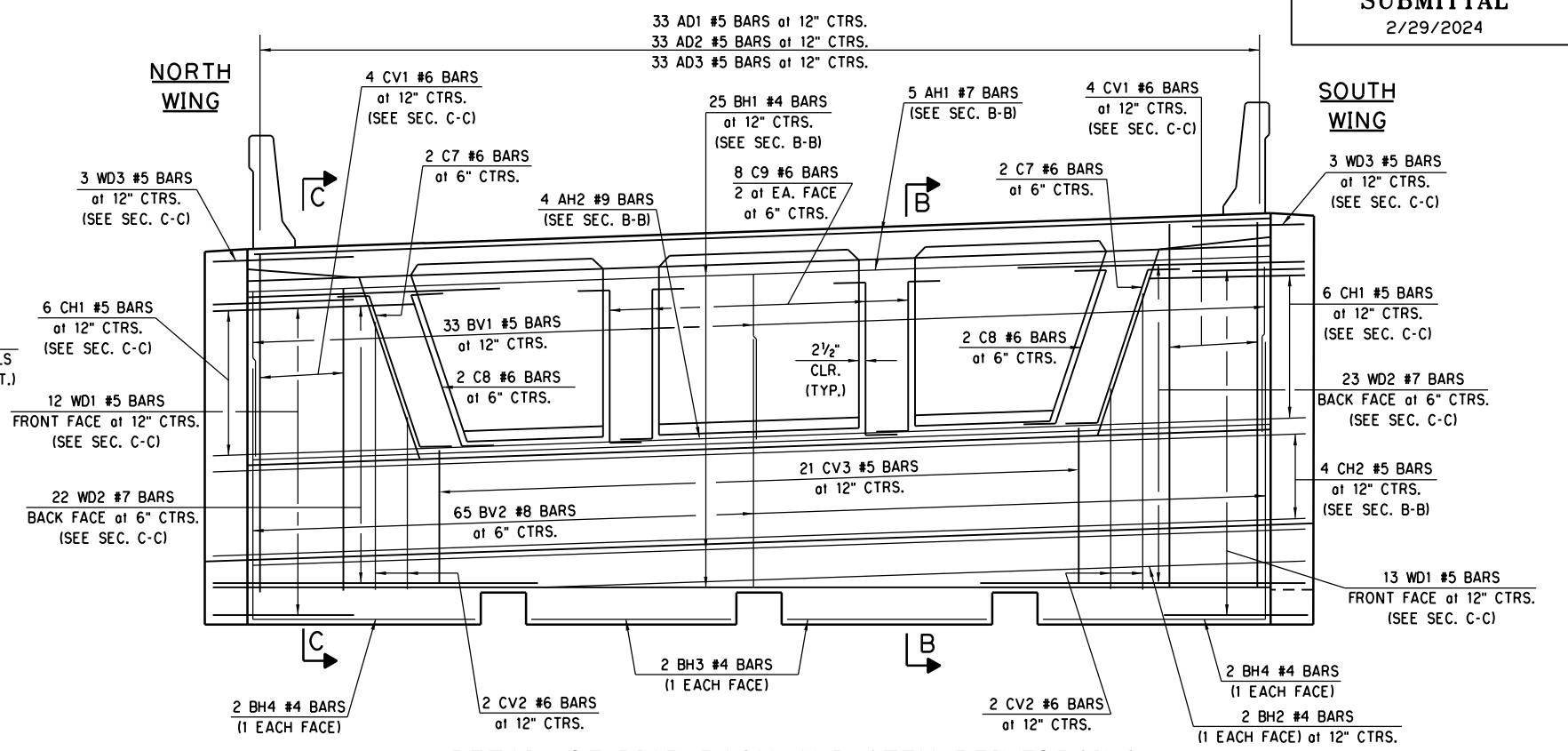

DETAIL OF DIAPHRAGM AND STEM REINFORCING

NOTE: FOR SEC. B-B AND SEC. C-C, SEE SHEET 3 OF 3.

ABUTMENT NO. 2 BAR LIST - TWO WINGS
(EPOXY COATED)

MARK	NO.	SIZE	FORM	SPACING	LENGTH	LENGTH VARIATION
WH1	12	#7	STR.	6" C/C	28'-2"	--
WH2	6	#5	STR.	12" C/C	28'-2"	--
WH3	36	#7	BNT.	6" C/C	29'-9" AVG.	28'-4" TO 31'-2"
WH4	18	#5	STR.	12" C/C	29'-8" AVG.	28'-4" TO 31'-0"
WH5	2	#7	STR.	AS SHOWN	26'-6"	--
WH6	2	#5	STR.	AS SHOWN	26'-6"	--
WH7	4	#8	STR.	AS SHOWN	31'-5"	--
WV1	6	#5	STR.	12" C/C	①	--
WV2	8	#4	STR.	12" C/C	5'-4" AVG.	3'-10" TO 6'-10"
WV3	104	#4	STR.	12" C/C	12'-1 1/2" AVG.	11'-11" TO 12'-4"
WV4	4	#5	BNT.	AS SHOWN	14'-7"	--

① LENGTH:
12'-4" - NORTH
12'-11" - SOUTH

NOTE: FOR STEM AND DIAPHRAGM BARLIST, SEE "SUPERSTRUCTURE DETAILS", SHEET 2 OF 5.

NOTE: ALL REINFORCING STEEL TO HAVE A 2" CLEARANCE, UNLESS OTHERWISE SHOWN OR NOTED.

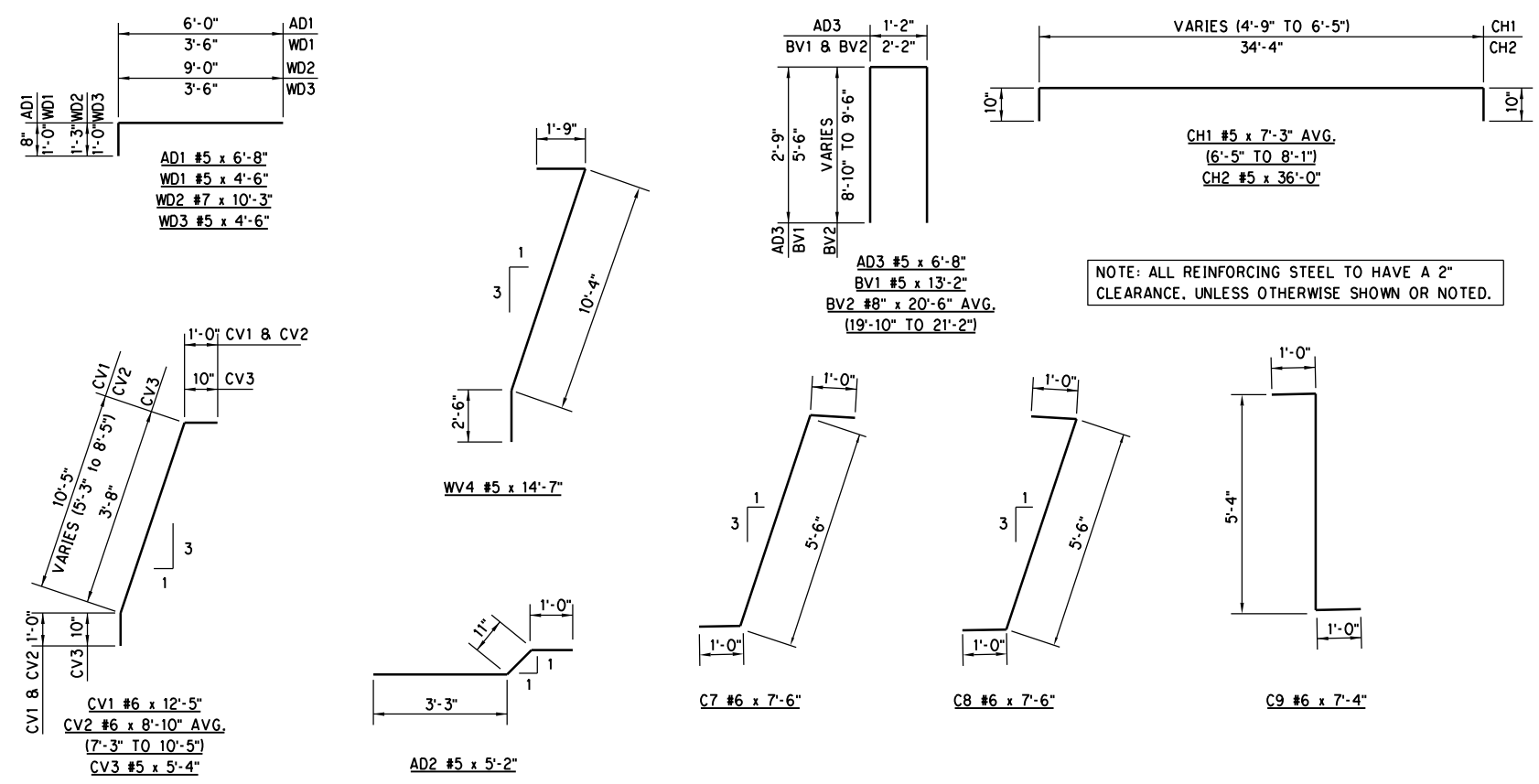

3/1/2024 10:35:43 AM H:\PROJECTS\2789_CrossRoads_Phase 4\Bridges\Drawings\Ph4 Bridges\Bridges L\0903208 P4 Br L Abut.dgn

DESIGN		PHASE 4	OKLAHOMA COUNTY
DRAWN		BRIDGE "L"	RAMP "L" OVER RAMP "A"
CHECKED		ABUTMENT DETAILS ABUTMENT NO. 2 (SHEET 2 OF 3)	
APPROVED			
SQUAD	POE	STATE JOB NO. 09032108	SHEET NO. B143

NOTE: TOP SLAB SUPERSTRUCTURE REINFORCING OMITTED FROM SECTION B-B FOR CLARITY.

NOTE: FOR DETAILS OF REINF. IN PRESTRESSING BEARING SEAT, REFER TO "BEARING ASSEMBLY DETAILS" SHEET.

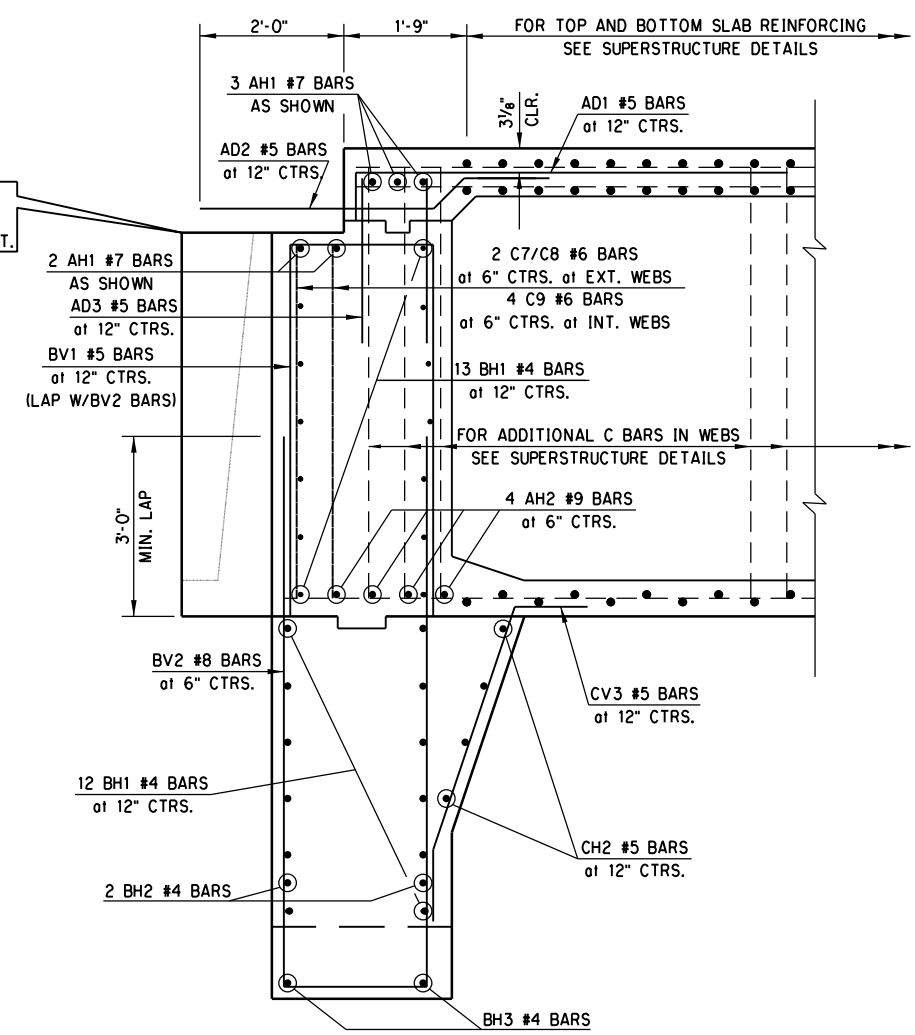

SECTION B-B

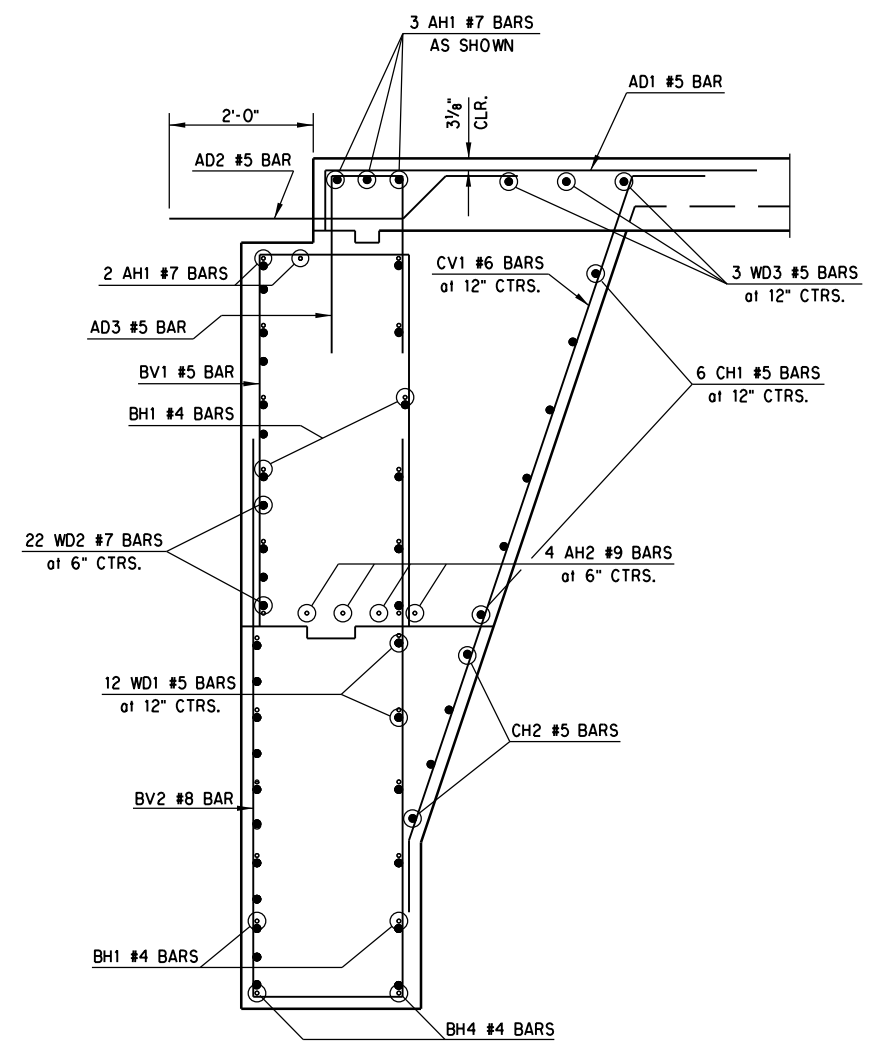

SECTION C-C

3/1/2024 10:35:45 AM H:\PROJECTS\2789_CrossRoads_Phase 4\Bridges\Drawings\Ph4 Bridges\Bridges L\0903208 P4 Br L Abut.dgn

PHASE 4		OKLAHOMA COUNTY	
BRIDGE "L"		RAMP "L" OVER RAMP "A"	
DESIGN		ABUTMENT DETAILS ABUTMENT NO. 2 (SHEET 3 OF 3) STATE JOB NO. 09032(08) SHEET NO. B144	
DRAWN			
CHECKED			
APPROVED			
SQUAD	POE		

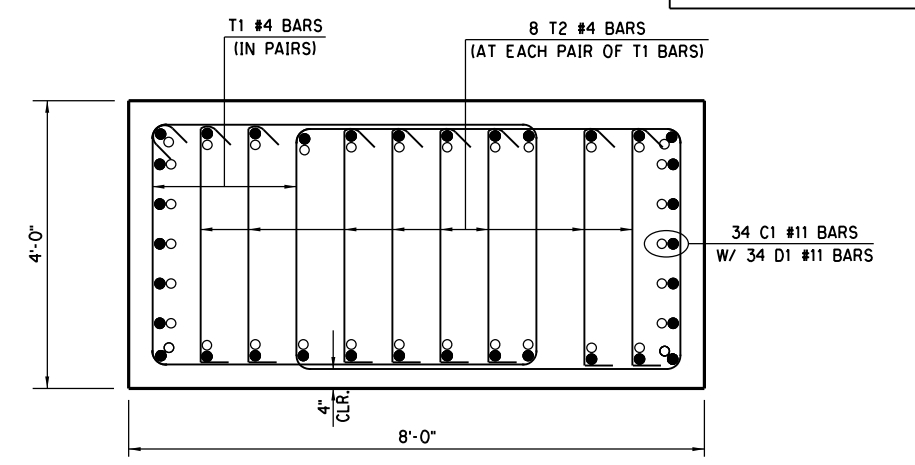
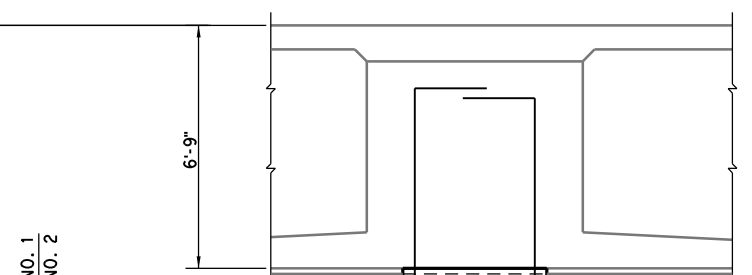
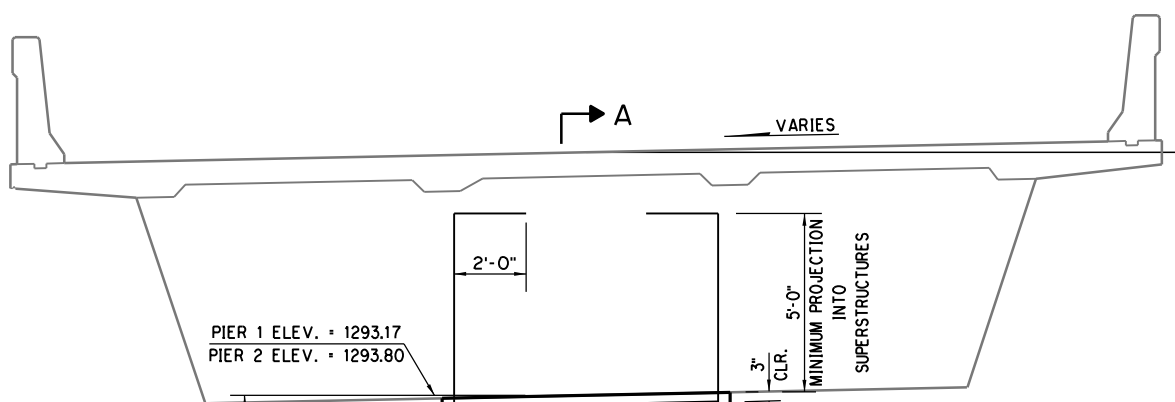

SECTION B-B

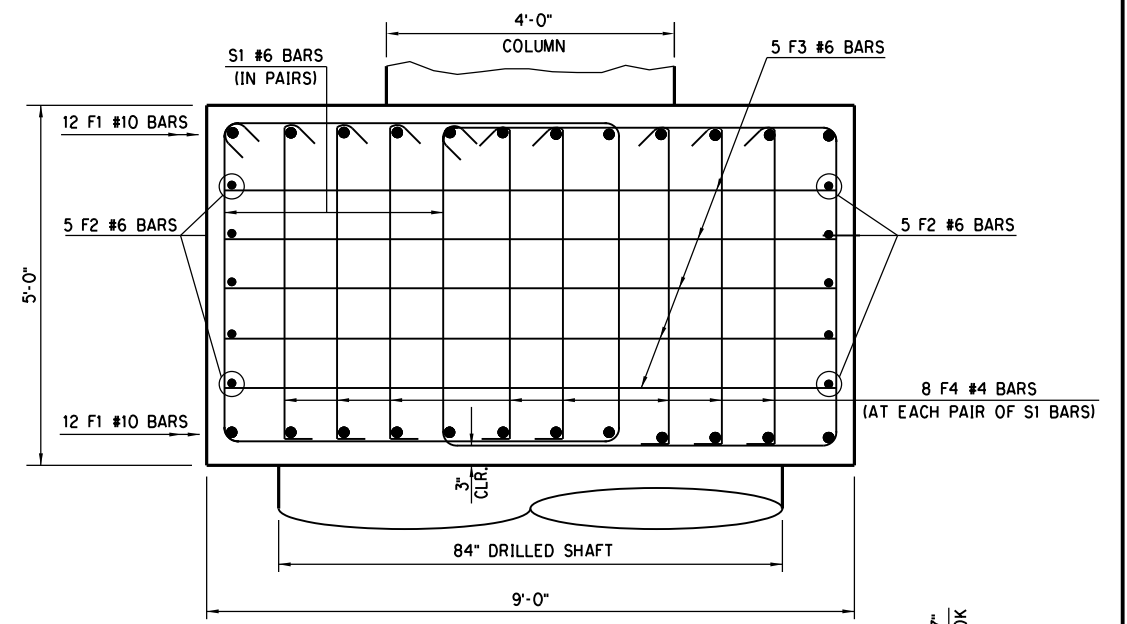

SECTION D-D

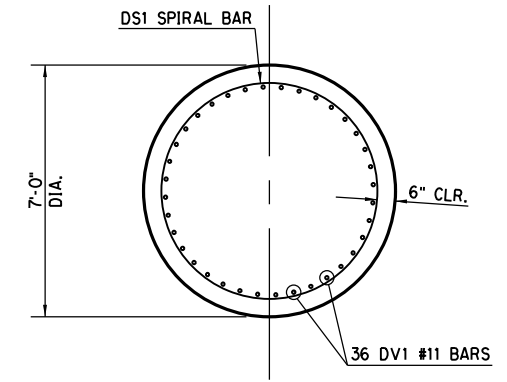
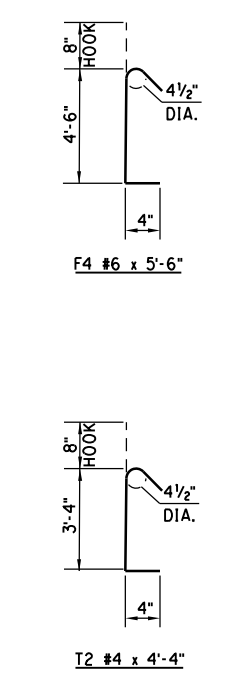

SECTION C-C

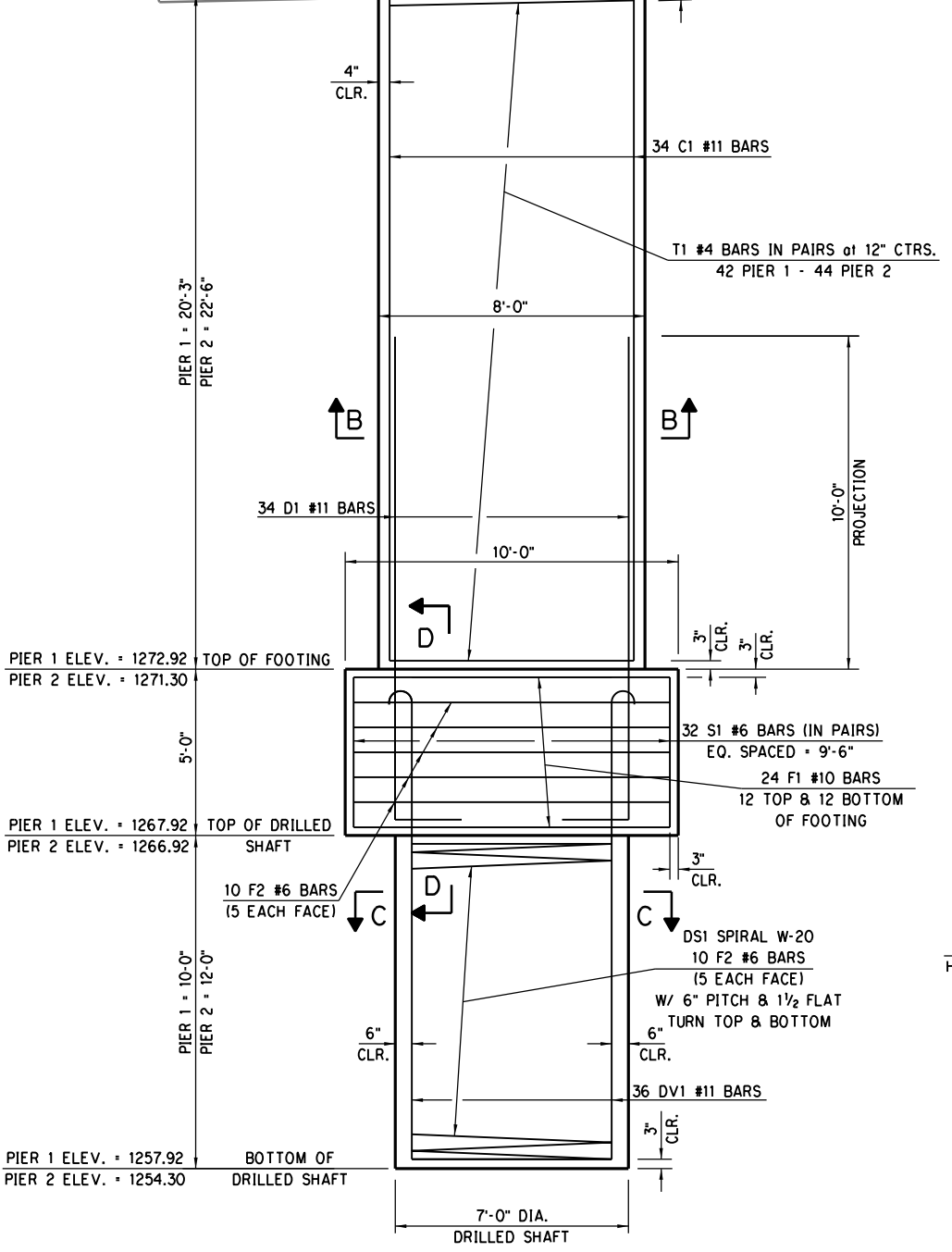
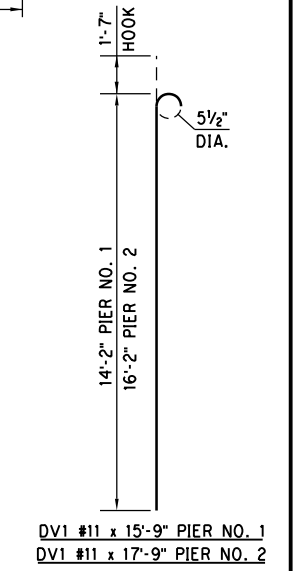

DETAIL OF REINFORCING AT PIER

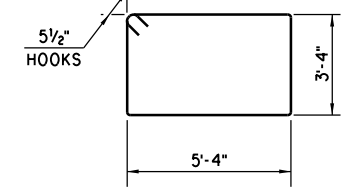
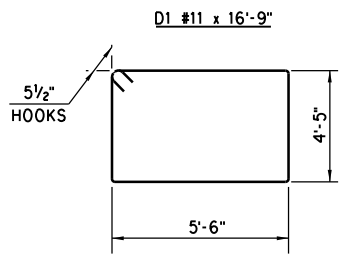
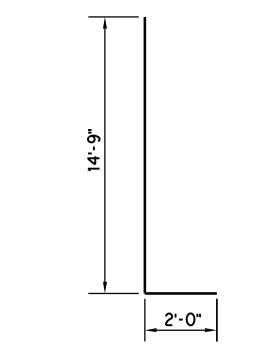
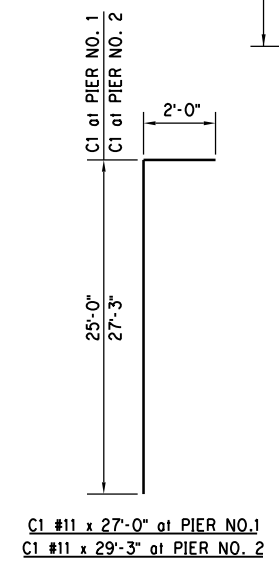

ALL BENT BAR DIMENSIONS ARE OUT TO OUT.

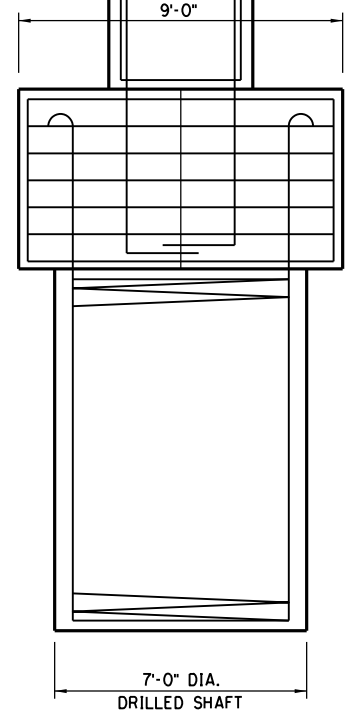

SECTION A-A

DESIGN		PHASE 4	OKLAHOMA COUNTY
DRAWN		BRIDGE "L"	RAMP "L" OVER RAMP "A"
CHECKED		PIER DETAILS (SHEET 1 OF 2)	
APPROVED			
SQUAD	POE		
		STATE JOB NO. 09032(08)	SHEET NO. B145

3/1/2024 10:35:46 AM H:\PROJECTS\2789_CrossRoads_Phase_4\Bridges\Drawings\Ph4 Bridges\Bridge L\0903208 P4 Br L Pier.dgn

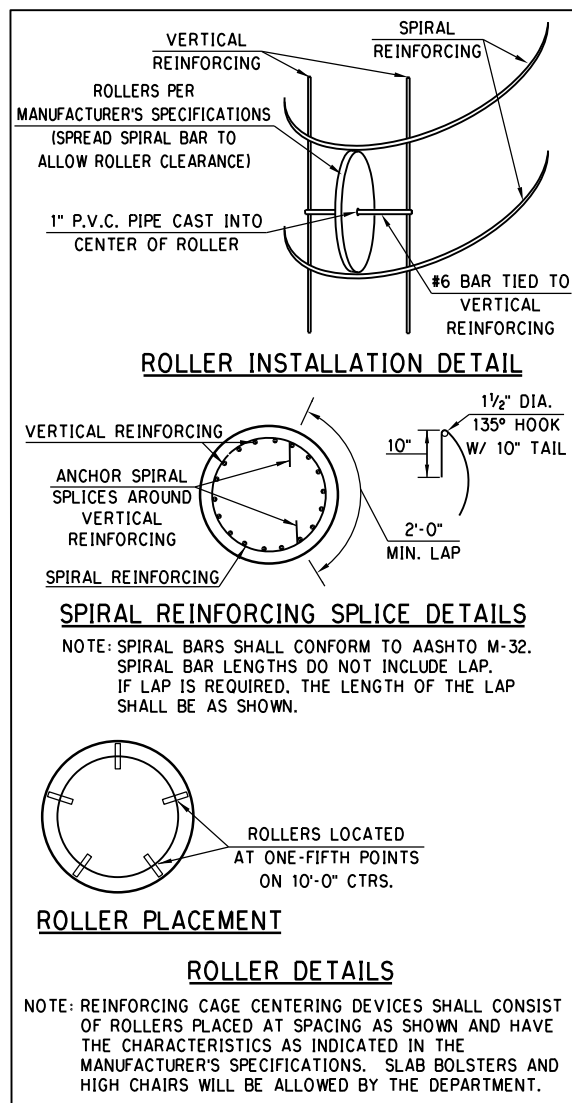

**BAR LIST - ONE PIER
(EPOXY COATED)**

MARK	NO.	SIZE	FORM	SPACING	LENGTH
C1	34	#11	BNT.	EQUAL	①
D1	34	#11	BNT.	EQUAL	16'-9"
F1	24	#10	STR.	EQUAL	9'-6"
F2	10	#6	STR.	EQUAL	9'-6"
F3	10	#6	STR.	EQUAL	8'-6"
F4	128	#4	BNT.	EQUAL	5'-6"
S1	32	#6	BNT.	EQUAL	20'-9"
T1	②	#4	BENT	12" C/C	18'-3"
T2	②	#4	BENT	12" C/C	4'-4"

BAR LIST - 84" DRILLED SHAFT

▲ DS1	1	W-20	BNT.	EQUAL	①
▲ DV1	36	#11	BNT.	EQUAL	①

▲ NON EPOXY COATED

① LENGTH:
C1 - PIER #1 = 27'-0"
PIER #2 = 29'-3"

* DS1 - PIER #1 = 416'-6"
PIER #2 = 492'-0"

DV1 - PIER #1 = 15'-9"
PIER #2 = 17'-9"

② NUMBER:
T1 - PIER #1 = 43
PIER #2 = 44

T2 - PIER #1 = 168
PIER #2 = 176

* LENGTH SHOWN DOES NOT INCLUDE ANY LAPS FOR SPLICES. CONTRACTOR MAY ADD SPLICES AS NECESSARY, BUT PAYMENT WILL NOT BE MADE FOR EXTRA LENGTH REQUIRED. ADD 3'-8" FOR EACH SPLICE.

QUANTITIES - ONE PIER

ITEM	UNIT	PIER NO. 1	PIER NO. 2
SUBSTRUCTURE EXCAVATION COMMON	C.Y.	187.00	187.00
SUBSTRUCTURE EXCAVATION ROCK	C.Y.	122.00	122.00
CLASS AA CONCRETE	C.Y.	40.70	43.40
EPOXY COATED REINFORCING STEEL	LB.	11,625.00	12,075.00
DRILLED SHAFT 84" DIAMETER	L.F.	10.00	12.00

3/1/2024 10:35:47 AM H:\PROJECTS\2789_CrossRoads_Phase_4\Bridges\Drawings\Ph4 Bridges\Drawings\0903208 P4 Br L Pier.dgn

DESIGN		PHASE 4	OKLAHOMA COUNTY
DRAWN		BRIDGE "L"	RAMP "L" OVER RAMP "A"
CHECKED		PIER DETAILS (SHEET 2 OF 2)	
APPROVED			
SQUAD	POE		
		STATE JOB NO. 09032(08)	SHEET NO. B146

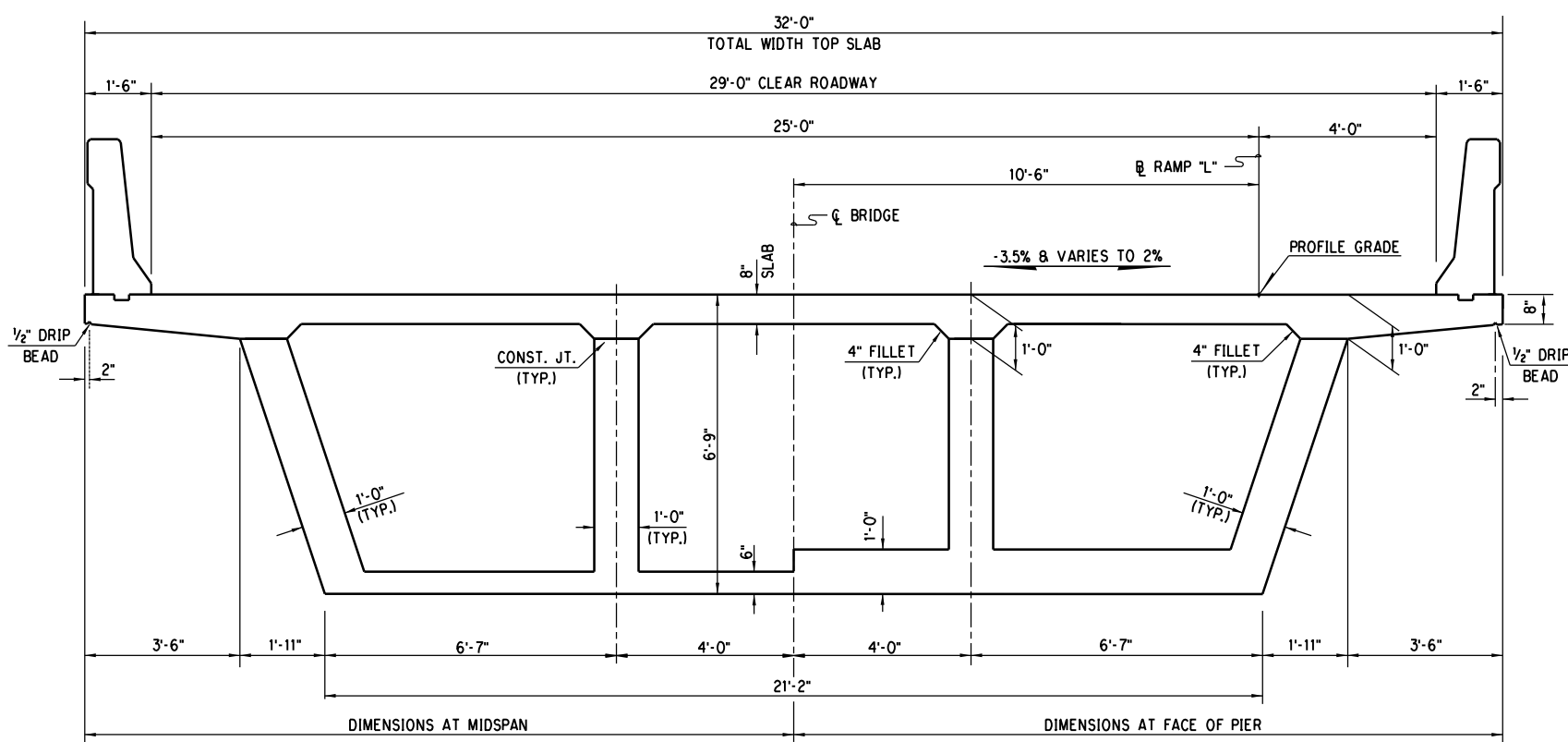

TYPICAL SECTION

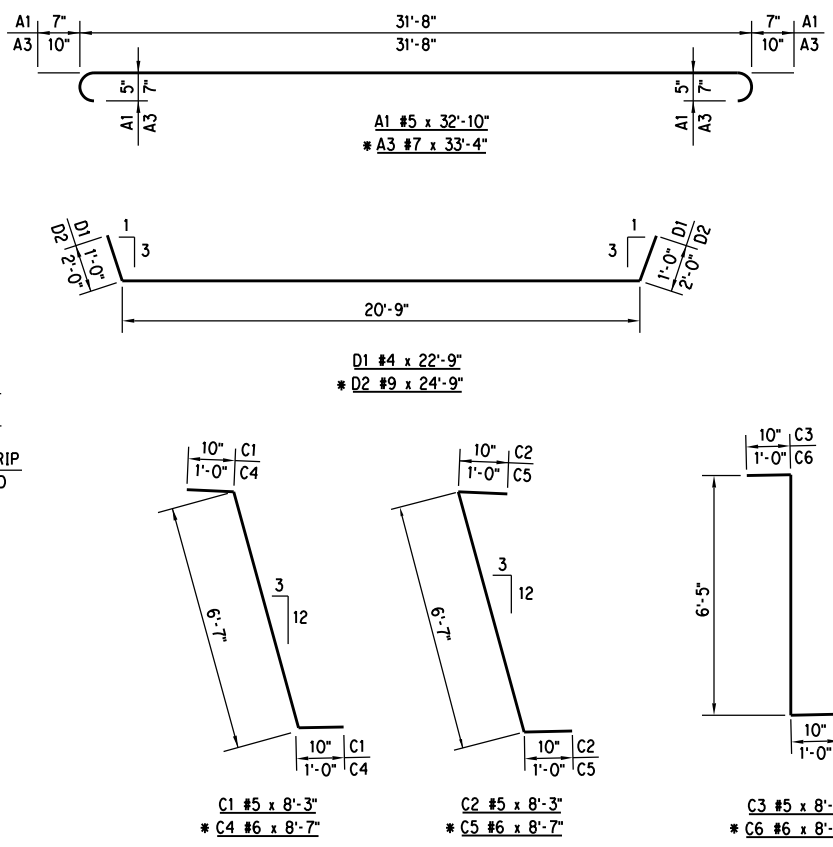

* THESE BARS TO BE USED IN ANCHORAGE ZONES AT ABUTMENT STEMS. SEE DETAILS SHEET 2 OF 6.

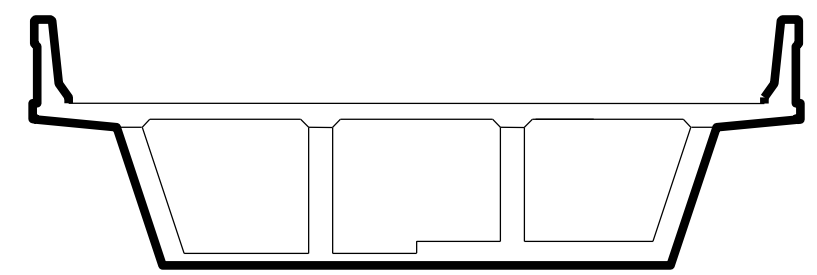

WATER REPELLENT SURFACE TREATMENT

SURFACES INDICATED WITH HEAVY LINES SHALL BE TREATED WITH A PENETRATING WATER REPELLENT SEALER.

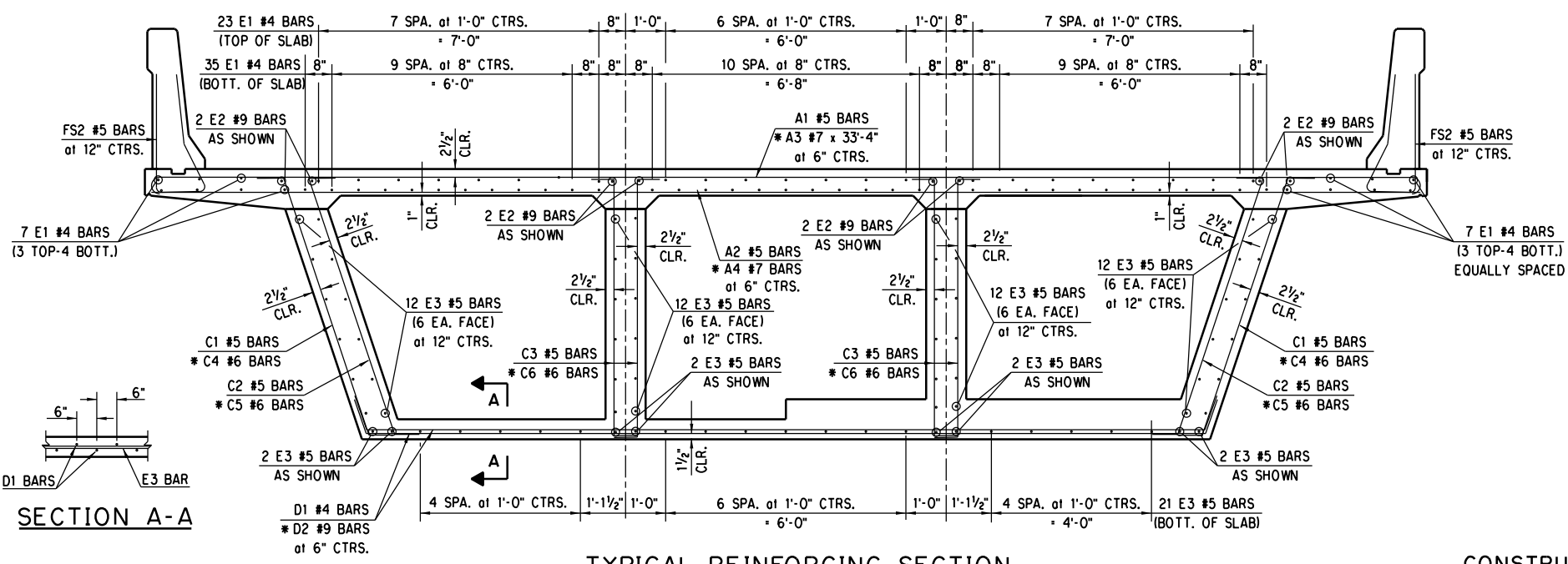

TYPICAL REINFORCING SECTION

SUPERSTRUCTURE QUANTITIES

ITEM	UNIT	TOTAL
42" F-SHAPED PARAPET	L.F.	827.00
① CLASS P CONCRETE	C.Y.	1,029.80
① EPOXY COATED REINFORCING STEEL	LB.	197,950.00
STRUCTURAL STEEL A36	LB.	792.00
WATER REPELLENT (VISUALLY INSPECTED)	S.Y.	2,704.00
PRESTRESSING	L.SUM	1.00

① QUANTITIES SHOWN INCLUDE QUANTITIES FOR ABUTMENT STEMS AND DIAPHRAGMS.

CONSTRUCTION JOINT NOTE

CONTACT SURFACES ARE TO BE CLEAN, FREE OF LAITANCE, AND INTENTIONALLY ROUGHENED TO FULL AMPLITUDE, APPROXIMATELY 1/4".

DESIGN		PHASE 4	OKLAHOMA COUNTY
DRAWN		BRIDGE "L"	RAMP "L" OVER RAMP "A"
CHECKED		SUPERSTRUCTURE DETAILS (SHEET 1 OF 6)	
APPROVED			
SQUAD	POE	STATE JOB NO. 09032(08)	SHEET NO. B147

3/1/2024 10:35:50 AM H:\PROJECTS\2789_Crossroads_Phase 4\Bridges\Drawings\Ph4 Bridges\Bridges L\0903208 P4 Br L SUPER.dgn

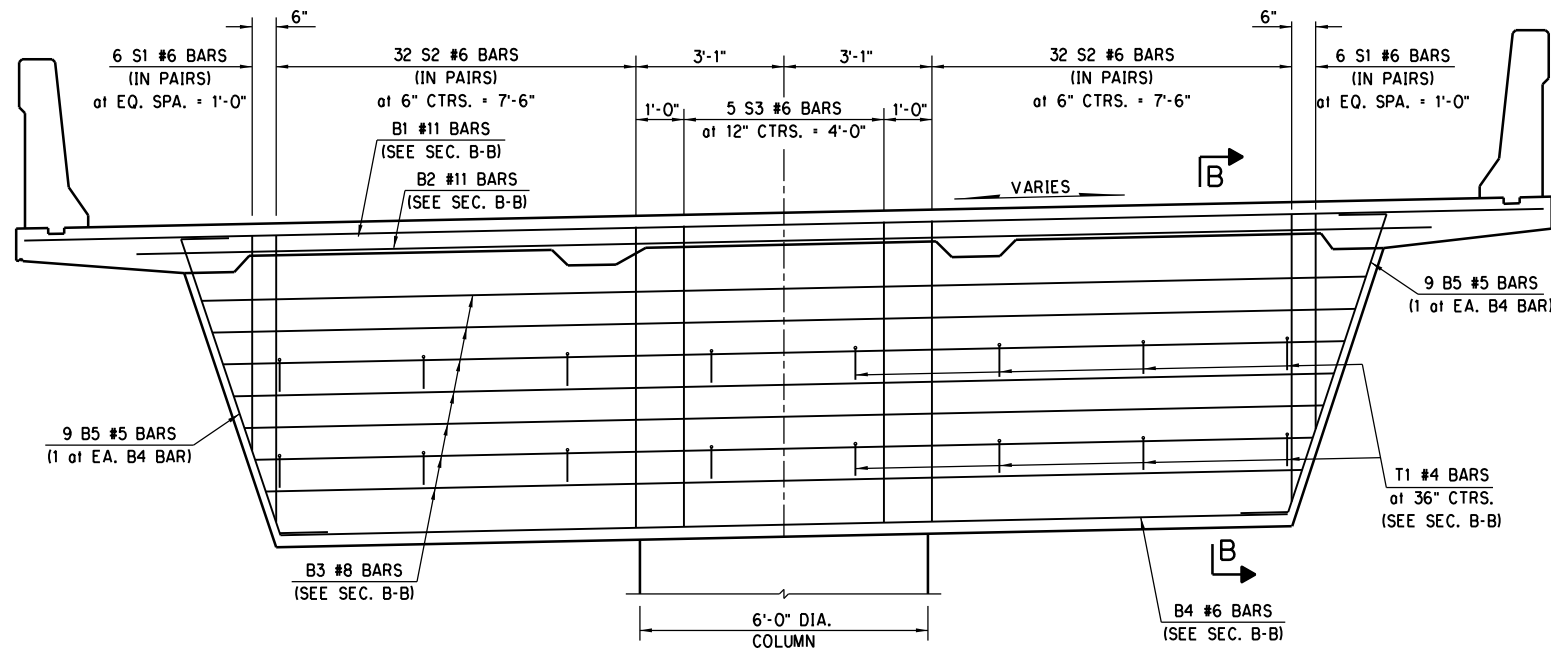

DETAIL OF REINFORCING AT PIER

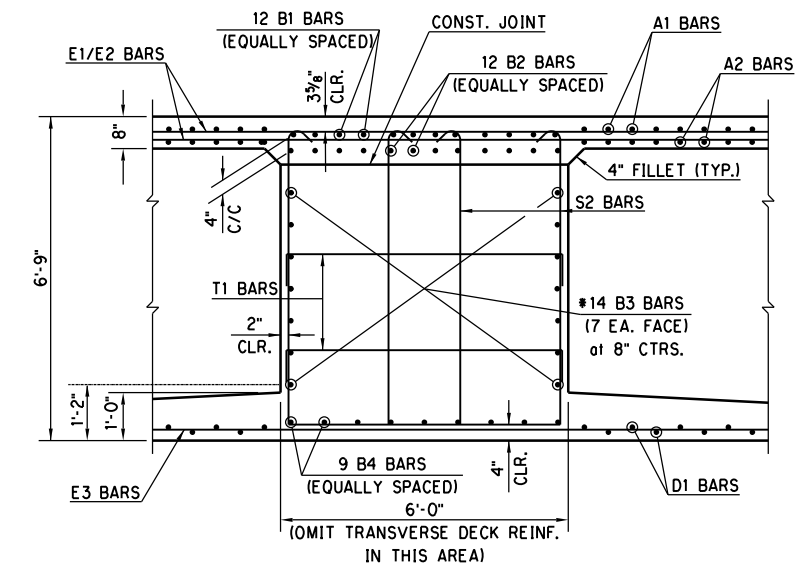

SECTION B - B

* ADJUST SPACING TO MISS PRESTRESSING DUCTS.

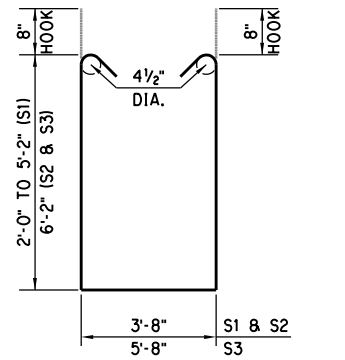
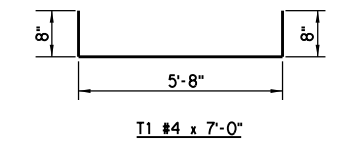

BAR LIST (EPOXY COATED)						
MARK	NO.	SIZE	FORM	SPACING	LENGTH	LENGTH VARIATION
A1	779	#5	BNT.	6" C/C	32'-10"	--
A2	779	#5	STR.	6" C/C	31'-8"	--
A3	20	#7	BNT.	6" C/C	33'-4"	--
A4	20	#7	STR.	6" C/C	31'-8"	--
AD1	66	#5	BNT.	12" C/C	6'-8"	--
AD2	66	#5	BNT.	12" C/C	5'-2"	--
AD3	66	#5	BNT.	12" C/C	6'-8"	--
AH1	10	#7	STR.	AS SHOWN	31'-8"	--
AH2	8	#9	STR.	6" C/C	31'-8"	--
B1	24	#11	STR.	AS SHOWN	31'-8"	--
B2	24	#11	STR.	AS SHOWN	27'-0"	--
B3	28	#8	STR.	8" C/C	22'-11" AVG.	21'-9" TO 24'-1"
B4	18	#6	STR.	AS SHOWN	20'-9"	--
B5	36	#5	STR.	AS SHOWN	8'-3"	--
BH1	60	#4	STR.	12" C/C	31'-8"	--
BH2	4	#4	STR.	AS SHOWN	23'-6"	--
BH3	8	#4	STR.	AS SHOWN	6'-3"	--
BH4	8	#4	STR.	AS SHOWN	7'-0"	--
BV1	66	#5	BNT.	12" C/C	13'-2"	--
BV2	①	#8	BNT.	6" C/C	①	--
C1	610	#5	BNT.	AS SHOWN	8'-3"	--
C2	610	#5	BNT.	AS SHOWN	8'-3"	--
C3	1220	#5	BNT.	AS SHOWN	8'-1"	--
C4	52	#6	BNT.	AS SHOWN	8'-7"	--
C5	52	#6	BNT.	AS SHOWN	8'-7"	--

BAR LIST - CONT'D. (EPOXY COATED)						
MARK	NO.	SIZE	FORM	SPACING	LENGTH	LENGTH VARIATION
C6	104	#6	BNT.	AS SHOWN	8'-5"	--
C7	8	#6	BNT.	6" C/C	7'-6"	--
C8	8	#6	BNT.	6" C/C	7'-6"	--
C9	16	#6	BNT.	6" C/C	7'-4"	--
CH1	①	#5	BNT.	12" C/C	①	--
CH2	12	#5	BNT.	12" C/C	36'-0"	--
CV1	①	#6	BNT.	12" C/C	①	--
CV2	①	#6	BNT.	12" C/C	①	--
CV3	①	#5	BNT.	12" C/C	①	--
D1	779	#4	BNT.	6" C/C	22'-9"	--
D2	20	#9	BNT.	6" C/C	24'-9"	--
E1	72	#4	STR.	AS SHOWN	429'-2"	--
E2	8	#9	STR.	AS SHOWN	463'-10"	--
E3	73	#5	STR.	AS SHOWN	435'-2"	--
FS2	828	#5	BNT.	SEE STD.	7'-4"	--
H1	12	#6	BNT.	AS SHOWN	9'-10"	--
H2	6	#9	BNT.	AS SHOWN	11'-4"	--
L	84	#5	BNT.	SEE STD.	1'-3"	--
S1	24	#6	BNT.	6" C/C	12'-2" AVG.	9'-0" TO 15'-4"
S2	128	#6	BNT.	6" C/C	17'-4"	--
S3	10	#6	BNT.	12" C/C	19'-4"	--
T1	32	#4	BNT.	36" C/C	7'-0"	--
WD1	62	#5	BNT.	12" C/C	4'-6"	--
WD2	111	#7	BNT.	6" C/C	10'-3"	--
WD3	12	#5	BNT.	12" C/C	4'-6"	--

① NUMBER & LENGTH: ABUT. NO. 1
BV2 - 65 at 31'-0" AVG. (29'-10" TO 32'-2")
CH1 - 12 at 7'-3" AVG. (6'-5" TO 8'-1")
CV1 - 8 at 16'-11"
CV2 - 4 at 13'-5" AVG. (11'-10" TO 15'-0")
CV3 - 21 at 10'-3"
ABUT. NO. 2
65 at 20'-6" AVG. (19'-10" TO 32'-2")
12 at 7'-3" AVG. (6'-5" TO 8'-1")
8 at 12'-5"
4 at 8'-10" AVG. (7'-3" TO 10'-5")
21 at 5'-4"

② LENGTH SHOWN INCLUDES LAP: E1 = 8 at 2'-0"
E2 = 8 at 6'-4"
E3 = 8 at 2'-9"
③ LOCATED AT ACCESS HOLES. SEE SHEET 6 OF 6.

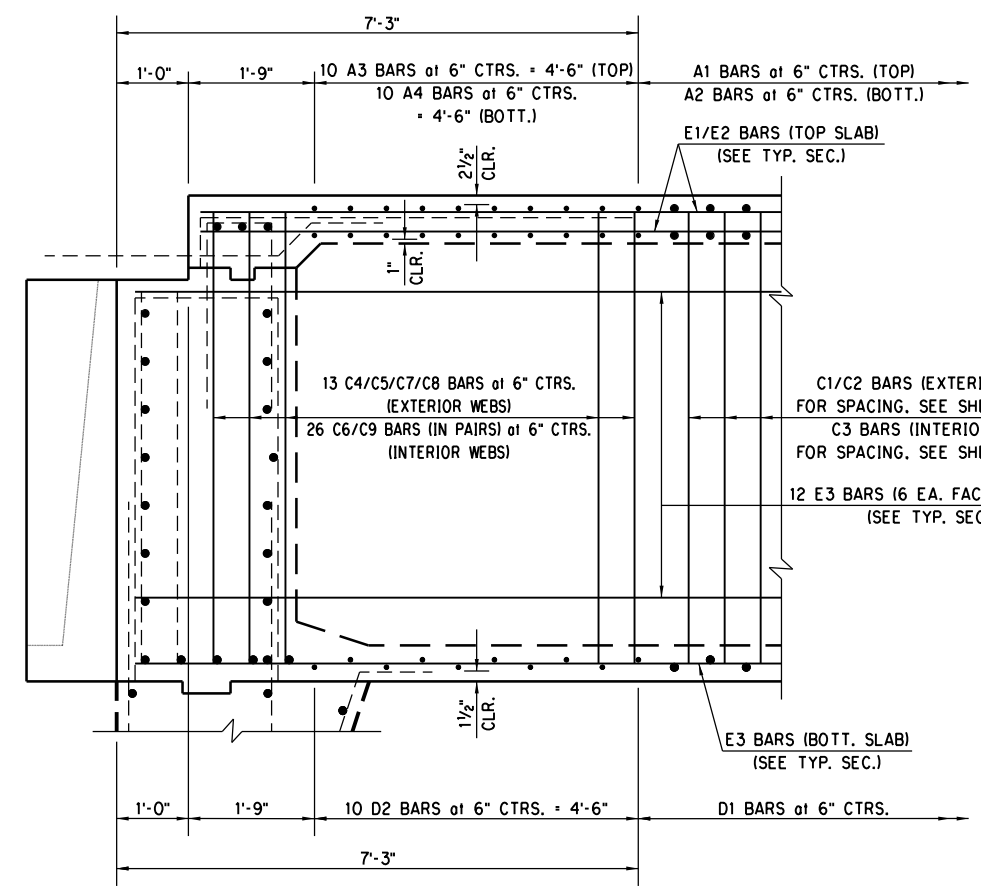

DETAIL OF GENERAL ANCHORAGE ZONE REINFORCEMENT AT ABUTMENT

NOTE: FOR ADDITIONAL REINFORCING IN DIAPHRAGM AND PRESTRESSING BEARING SEAT. SEE ABUTMENT DETAILS AND MISCELLANEOUS PRESTRESSING DETAILS.

DESIGN	
DRAWN	
CHECKED	
APPROVED	
SQUAD	POE

PHASE 4 OKLAHOMA COUNTY
BRIDGE "L" RAMP "L" OVER RAMP "A"

SUPERSTRUCTURE DETAILS
(SHEET 2 OF 6)

3/1/2024 10:35:52 AM H:\PROJECTS\2789_CrossRoads_Phase 4\Bridges\Dr-wings\Ph4 Bridges\Bridges\Bridges\0903208 P4 Br L SUPER.dgn

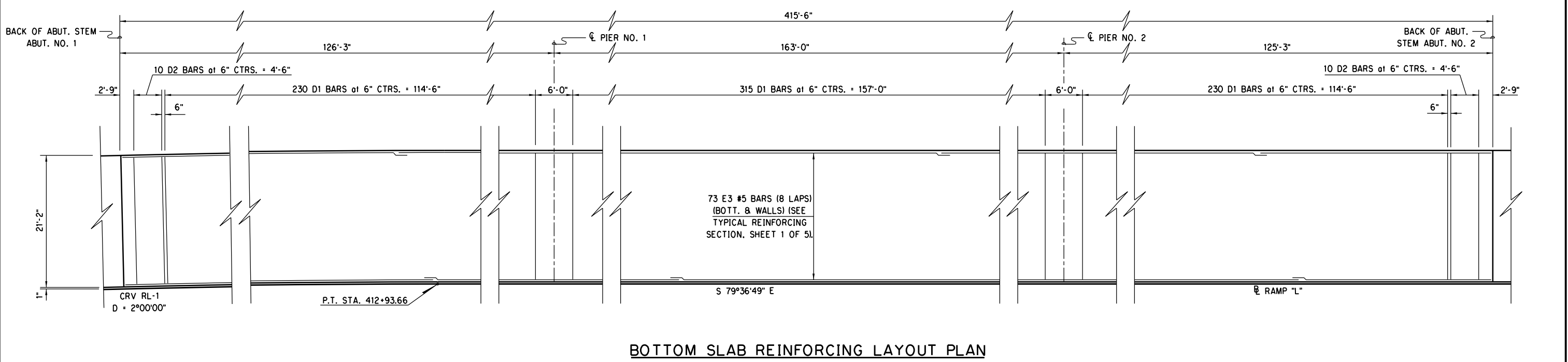
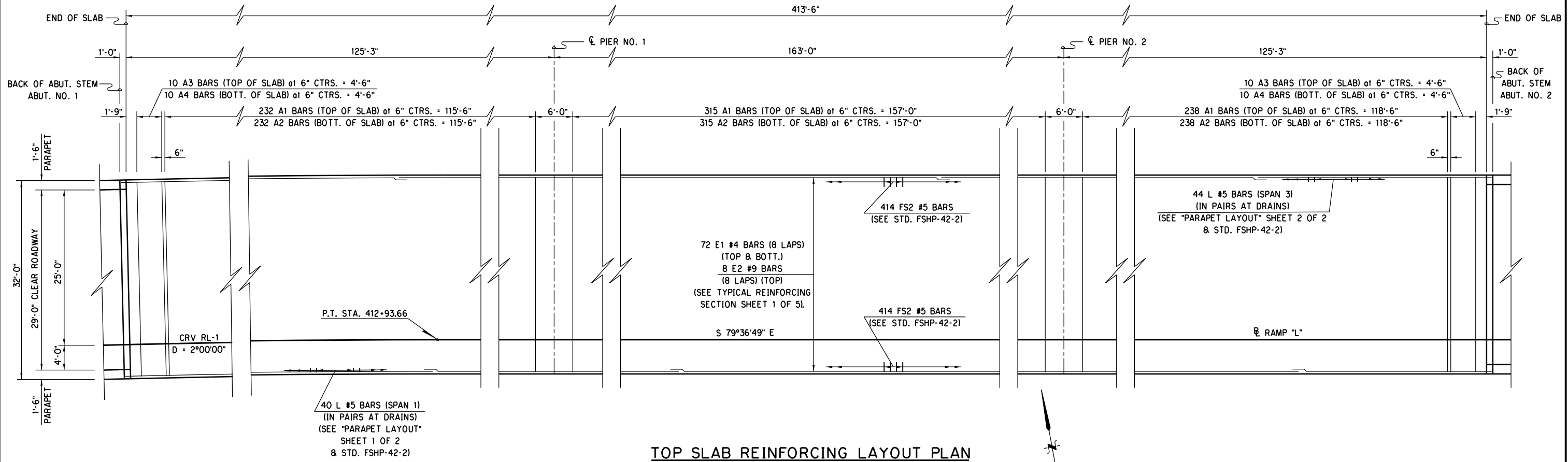

3/1/2024 10:35:55 AM H:\PROJECTS\2789_CrossRoads_Phase 4\Bridges\Drawings\Ph4 Bridges\Bridges L\0903208 P4 Br L SUPER.dgn

PHASE 4		OKLAHOMA COUNTY	
BRIDGE "L"		RAMP "L" OVER RAMP "A"	
DESIGN		SUPERSTRUCTURE DETAILS (SHEET 3 OF 6) STATE JOB NO. 09032(08) SHEET NO. B149	
DRAWN			
CHECKED			
APPROVED			
SQUAD	POE		

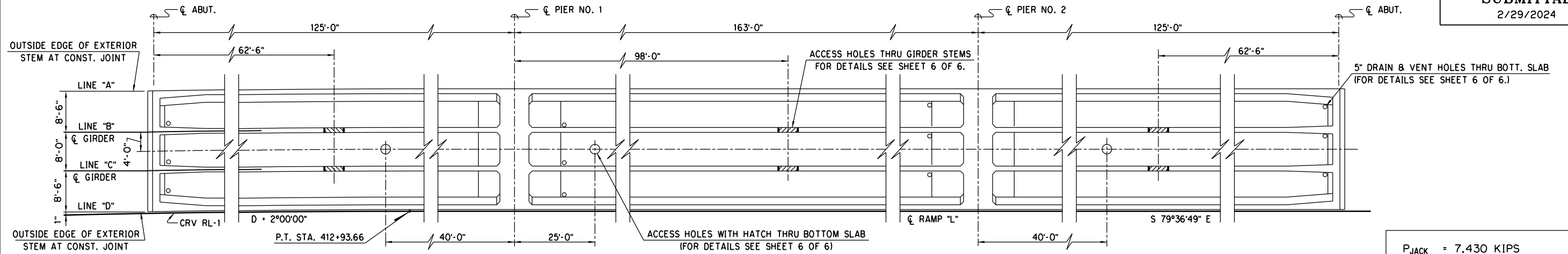

PLAN

$$P_{JACK} = 7,430 \text{ KIPS}$$

$$A_s \bar{A} \frac{P_{JACK}}{f's} = 36.70 \text{ IN}^2$$

$$f's = 270 \text{ KSI}$$

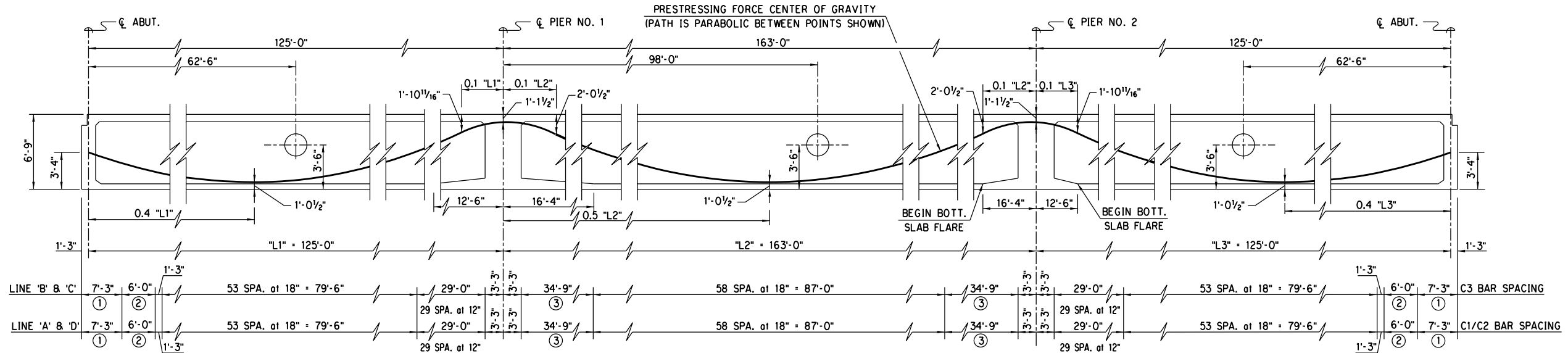

LONGITUDINAL SECTION

- ① FOR ANCHORAGE ZONE REINFORCING. SEE DETAIL ON SHEET 2 OF 6.
- ② 6 SPACES at 12"
- ③ 1 SPACE at 9" AND 34 SPACES at 12"

NOTE: FOR ADDITIONAL PRESTRESSING DETAILS, SEE "MISCELLANEOUS PRESTRESSING DETAILS" SHEET.

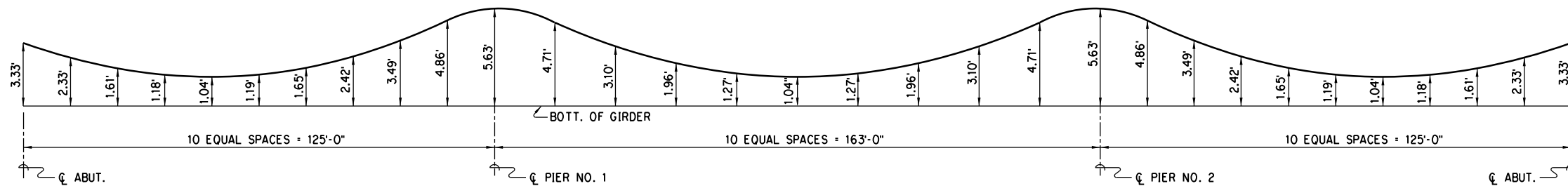

PRESTRESSING FORCE CENTER OF GRAVITY LAYOUT

DESIGN		PHASE 4	OKLAHOMA COUNTY
DRAWN		BRIDGE "L"	RAMP "L" OVER RAMP "A"
CHECKED		SUPERSTRUCTURE DETAILS (SHEET 4 OF 6)	
APPROVED			
SQUAD	POE	STATE JOB NO. 09032(08)	SHEET NO. B150

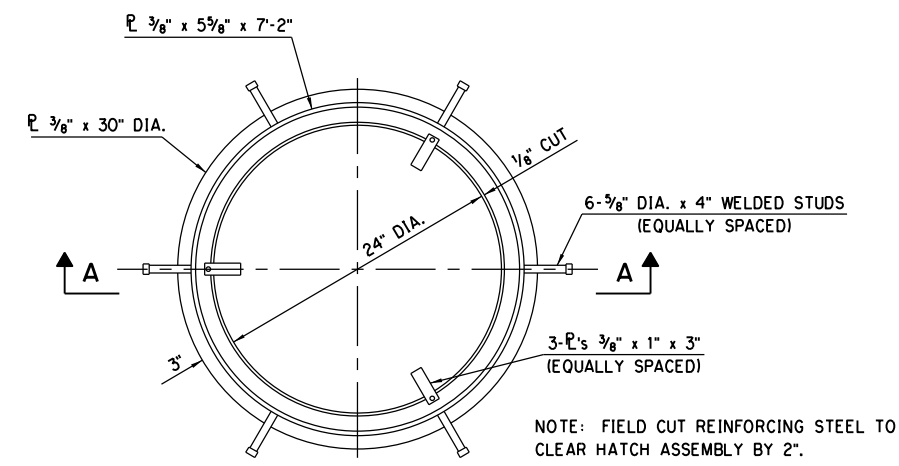

DETAIL OF HATCH ASSEMBLY

NOTE: 24" DIA. HATCHES TO BE GALVANIZED AFTER FABRICATION. WEIGHT OF HATCHES (132 LBS. EA.) IS INCLUDED IN STRUCTURAL STEEL QUANTITY. ALL COST OF MATERIALS, LABOR AND INCIDENTALS REQUIRED TO INSTALL HATCHES, COMPLETE AND IN PLACE, SHALL BE INCLUDED IN THE UNIT PRICE BID FOR "STRUCTURAL STEEL".

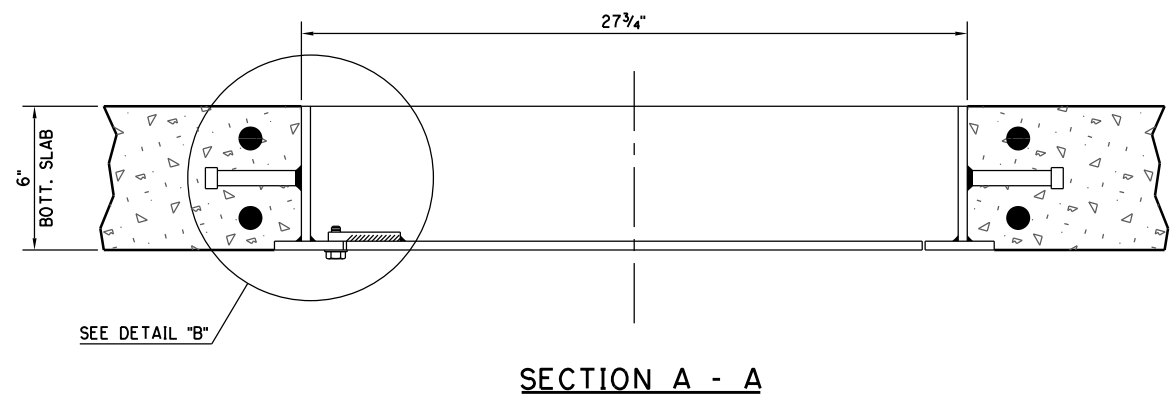

SECTION A - A

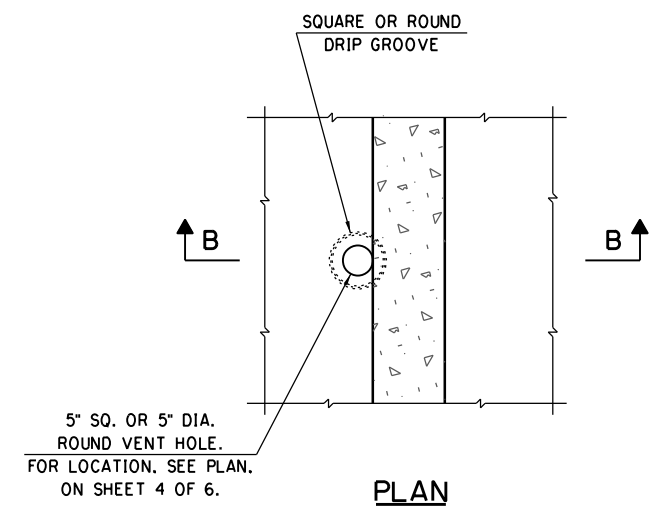

PLAN

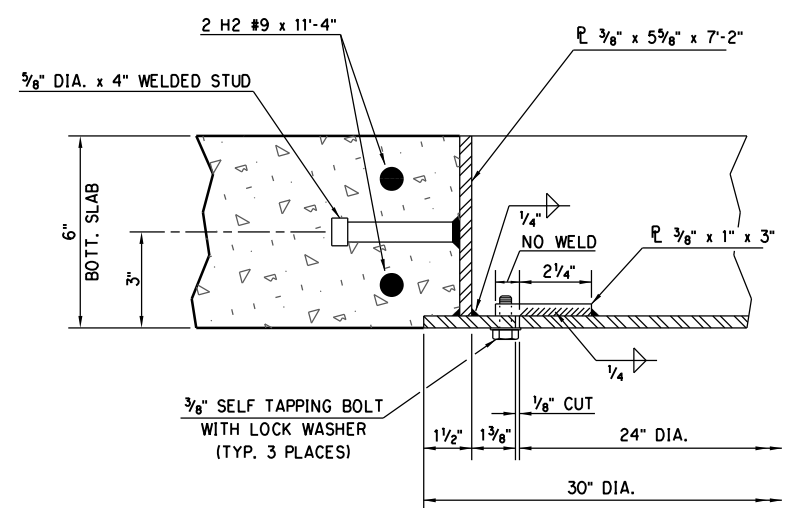

DETAIL "B"

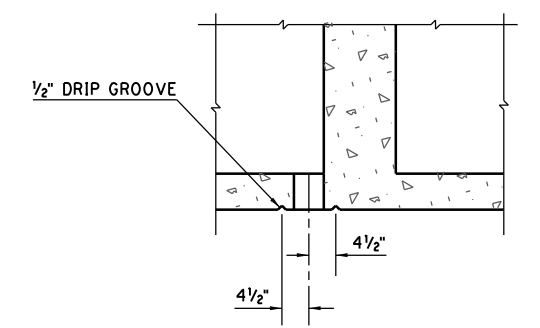

SECTION B - B

DETAIL OF DRAIN AND VENT HOLES

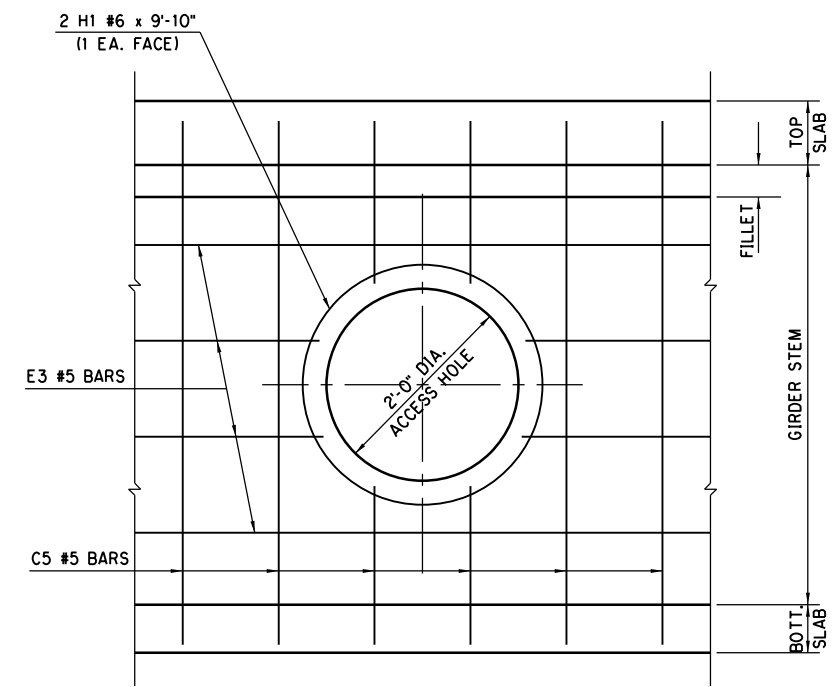

DETAIL OF ACCESS HOLE THRU GIRDER STEM

NOTE: FIELD CUT REINFORCING STEEL TO CLEAR ACCESS HOLE BY 2".

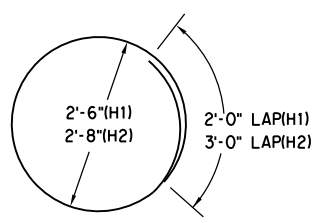

H1 #6 x 9'-10"
H2 #9 x 11'-4"

NOTE: FOR LOCATIONS OF ACCESS HOLES AND HATCHES, SEE SHEET 4 OF 6.

3/1/2024 10:36:00 AM H:\PROJECTS\2789_CrossRoads_Phase 4\Bridges\Drawings\Bridges\Bridges\0903208 P4 Br L Hatch.dgn

DESIGN		PHASE 4	OKLAHOMA COUNTY
DRAWN		BRIDGE "L"	RAMP "L" OVER RAMP "A"
CHECKED		SUPERSTRUCTURE DETAILS (SHEET 6 OF 6)	
APPROVED			
SQUAD	POE		
		STATE JOB NO. 09032(08)	SHEET NO. B152

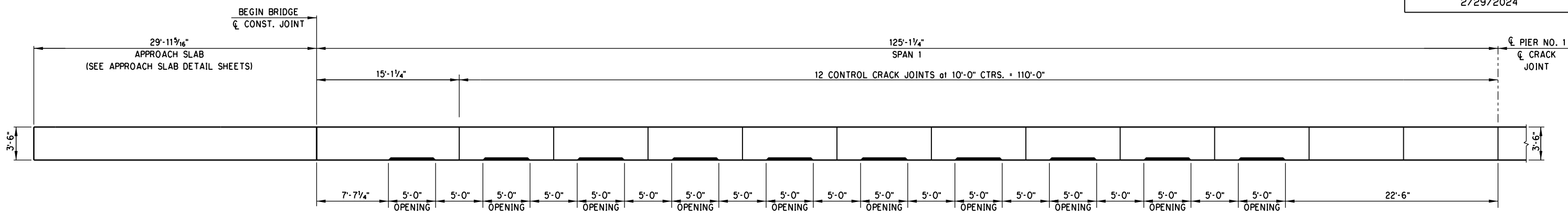

SOUTH PARAPET OPENING AND JOINT SPACING

SPAN NO. 1

(DIMENSIONS SHOWN ARE ALONG OUTSIDE EDGE OF SLAB)

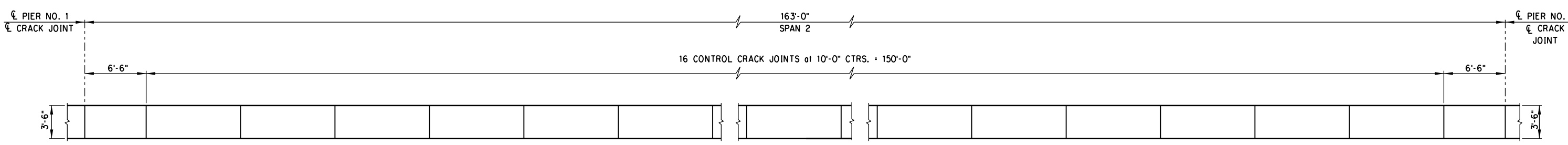

SOUTH PARAPET JOINT SPACING

SPAN NO. 2

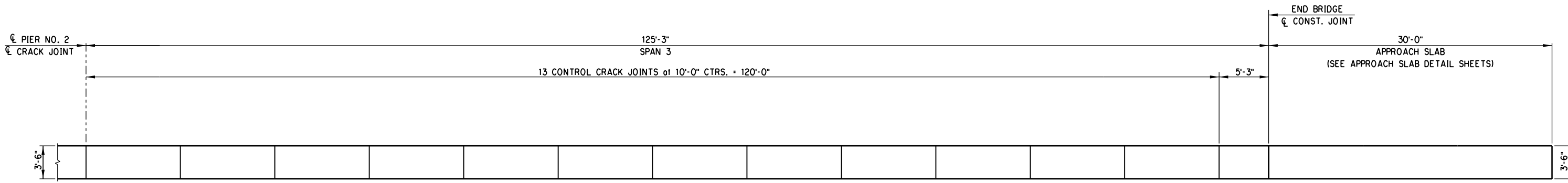

SOUTH PARAPET JOINT SPACING

SPAN NO. 3

NOTE: FOR ADDITIONAL DETAILS,
SEE STD. FSHP-42-2.

3/1/2024 10:36:02 AM H:\PROJECTS\2789_Crossroads_Phase 4\Bridges\Drawings\Ph4 Bridges\Bridges\0903208 P4 Br L Parapet Layout.dgn

PHASE 4		OKLAHOMA COUNTY	
BRIDGE "L"		RAMP "L" OVER RAMP "A"	
DESIGN		<p>PARAPET LAYOUT (SHEET 1 OF 2)</p> <p>STATE JOB NO. 09032(08) SHEET NO. B153</p>	
DRAWN			
CHECKED			
APPROVED			
SQUAD	POE		

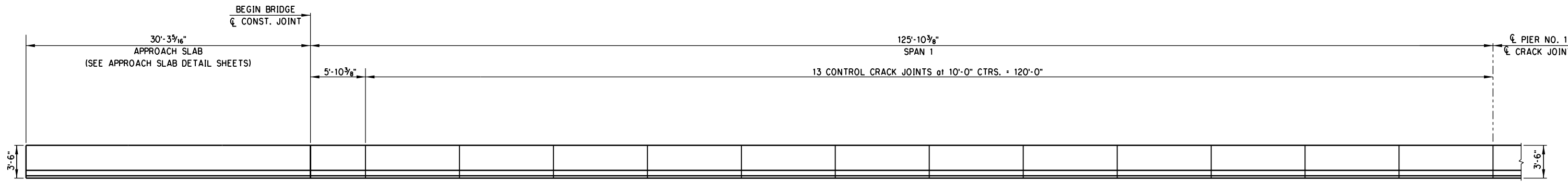

NORTH PARAPET JOINT SPACING
SPAN NO. 1
(DIMENSIONS SHOWN ARE ALONG OUTSIDE EDGE OF SLAB)

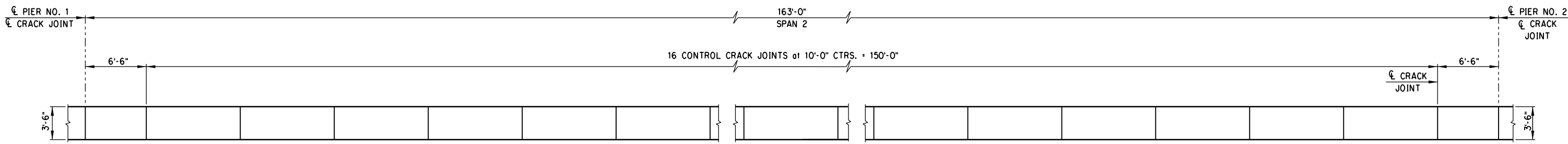

NORTH PARAPET JOINT SPACING
SPAN NO. 2

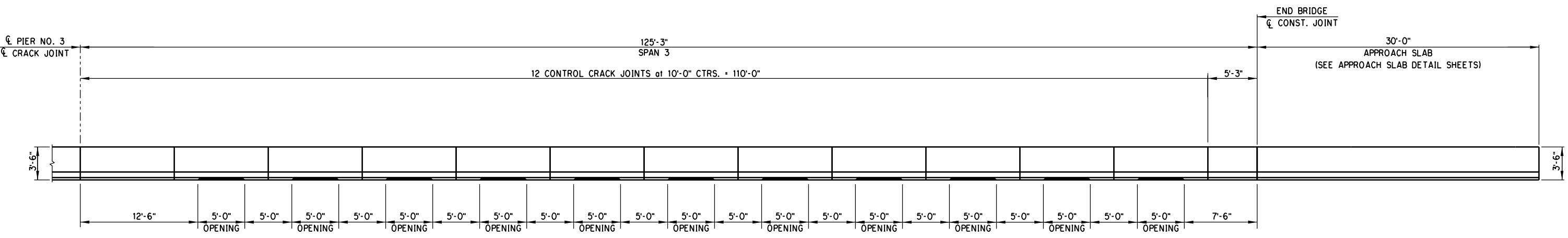

NORTH PARAPET OPENING AND JOINT SPACING
SPAN NO. 3

NOTE: FOR ADDITIONAL DETAILS.
SEE STD. FSHP-42-2.

3/1/2024 10:36:03 AM H:\PROJECTS\2789_CrossRoads_Phase 4\Bridges\Drawings\Ph4 Bridges\Bridges\Layout.dgn

PHASE 4		OKLAHOMA COUNTY	
BRIDGE "L"		RAMP "L" OVER RAMP "A"	
DESIGN		PARAPET LAYOUT (SHEET 2 OF 2)	
DRAWN			
CHECKED			
APPROVED			
SQUAD	POE		
		STATE JOB NO. 09032(08) SHEET NO. B154	

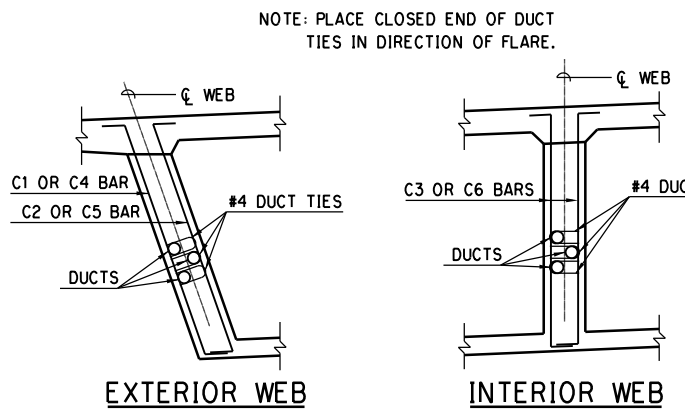

SECTION A - A

NOTE: THESE DETAILS APPLY ONLY IF PRESTRESSING SYSTEM USED REQUIRES DUCTS TO BE FLARED.

NOTE: NUMBER OF DUCTS SHOWN IS REPRESENTATIVE ONLY. ACTUAL NUMBER TO BE DETERMINED BY PRESTRESSING SYSTEM USED.

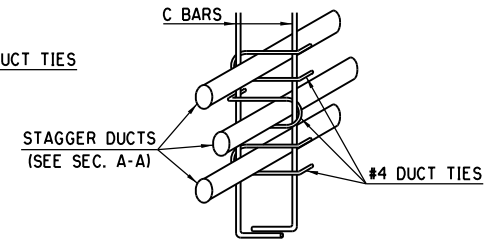

DUCT TIES PICTORIAL VIEW

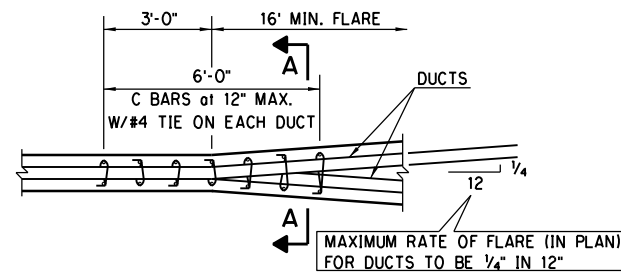

PLAN OF STIRRUP REINFORCEMENT AT FLARE OF GIRDER WEB

NOTES:
GIRDER WEB SHALL BE FLARED NEAR ANCHORAGE TO PROVIDE A MINIMUM OF 1 1/2" CONCRETE COVER TO STIRRUPS. THE MINIMUM LENGTH OF FLARE SHALL BE 16 FEET.
PLACE DUCT TIES AS SHOWN FOR FLARE OF GIRDER WEB. AT EACH LOCATION WHERE DUCTS CHANGE HORIZONTAL DIRECTION.
BAR REINFORCING INTERFERING WITH THE PRESTRESSING TENDON SHALL BE ADJUSTED AS APPROVED BY THE ENGINEER.
THE WORKING DRAWINGS OF THE PROPOSED PRESTRESSING SYSTEM SHALL INCLUDE ANY ADDITIONS OR REARRANGEMENT OF REINFORCING STEEL FROM THAT SHOWN ON THE PLANS. ANY ADDITIONAL REINFORCING STEEL, INCLUDING DUCT TIES SHALL BE EPOXY-COATED.
ALL COST OF ADDITIONAL REINFORCING STEEL IN FLARED GIRDER WEBS SHALL BE INCLUDED IN THE UNIT PRICE BID FOR PRESTRESSING.

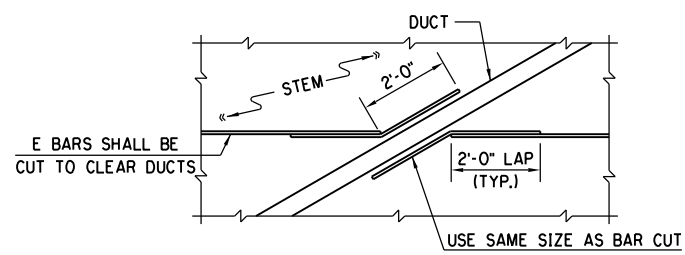

ADJUSTMENT OF WEB REINF. CONFLICTING WITH DUCTS

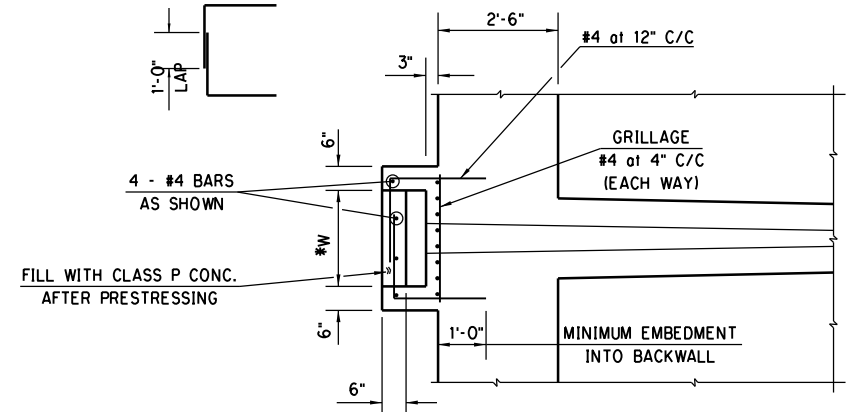

SECTION C - C

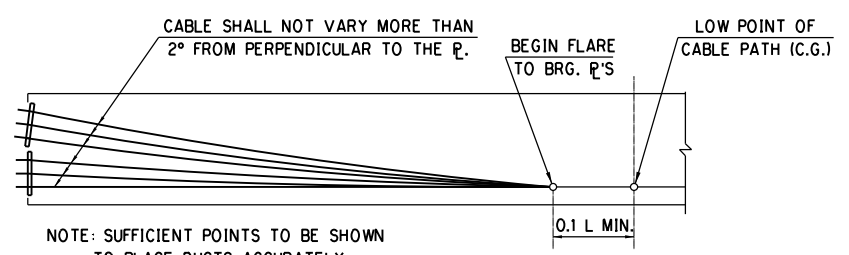

BEARING PLATE PRESTRESSING PATH

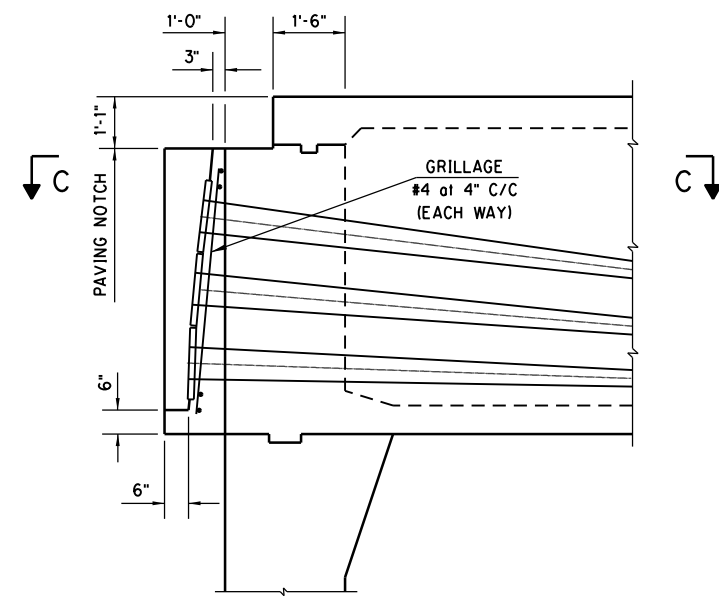

DETAIL OF BEARING SEAT FOR PRESTRESSING ANCHORAGE

* DIMENSION "W" TO BE DETERMINED BY PRESTRESSING SYSTEM USED.
** NOTE: PAVING NOTCH MAY BE REDUCED TO A MINIMUM OF 9" OVER BEARING SEAT TO ACCOMODATE BEARING PLATES. IF REDUCTION IS REQUIRED, PLACE 1" THICK EXPANDED POLYSTYRENE BETWEEN BEARING SEAT, ABUTMENT DIAPHRAGM AND APPROACH SLAB BLOCKOUT. PLACE 1/2" EXP. JOINT FILLER AT TOP OF BEARING SEAT.

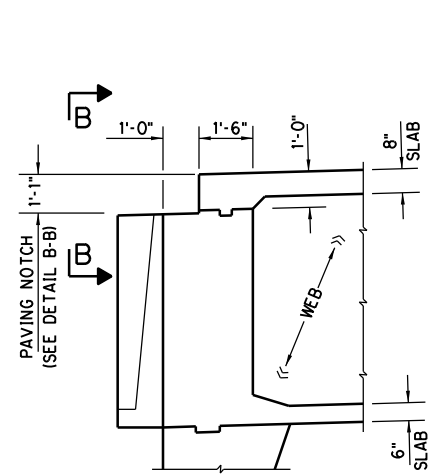

SECTION THRU ABUTMENT DIAPHRAGM

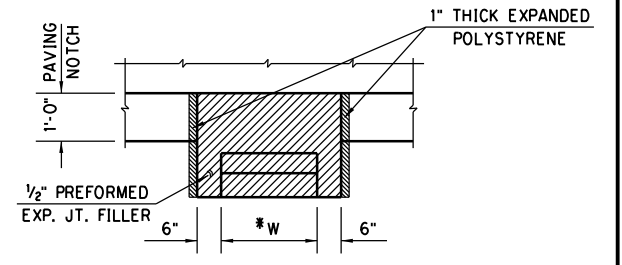

PLAN VIEW

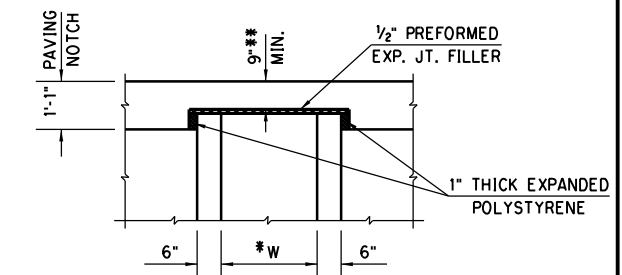

SECTION B - B

APPROACH SLAB PAVING NOTCH REDUCTION AT PRESTRESSING BEARING SEAT

NOTES:
THE BEARING SEAT DETAILS SHOWN FOR PRESTRESSING ANCHORAGE ARE ILLUSTRATIONS. WORKING DRAWINGS OF THE PROPOSED PRESTRESSING SYSTEM SHALL INCLUDE BEARING SEAT DETAILS APPROPRIATE FOR THE SYSTEM, INCLUDING REINFORCING STEEL AND CONCRETE DIMENSIONS.
REINFORCING STEEL IN THE BEARING SEAT SHALL BE EPOXY-COATED.
ALL COST OF REINFORCING STEEL AND CONCRETE IN THE BEARING SEAT SHALL BE INCLUDED IN THE PRICE BID FOR PRESTRESSING (LUMP SUM).

3/1/2024 10:36:05 AM H:\PROJECTS\2789_CrossRoads_Phase 4\Bridges\Drawings\Ph4 Bridges\Bridges\0903208 P4 Br L Prestress.dgn

PHASE 4		OKLAHOMA COUNTY	
DESIGN		BRIDGE "L" RAMP "L" OVER RAMP "A"	
DRAWN			
CHECKED			
APPROVED			
SQUAD	POE	STATE JOB NO. 09032(08) SHEET NO. B155	

MISCELLANEOUS PRESTRESSING DETAILS

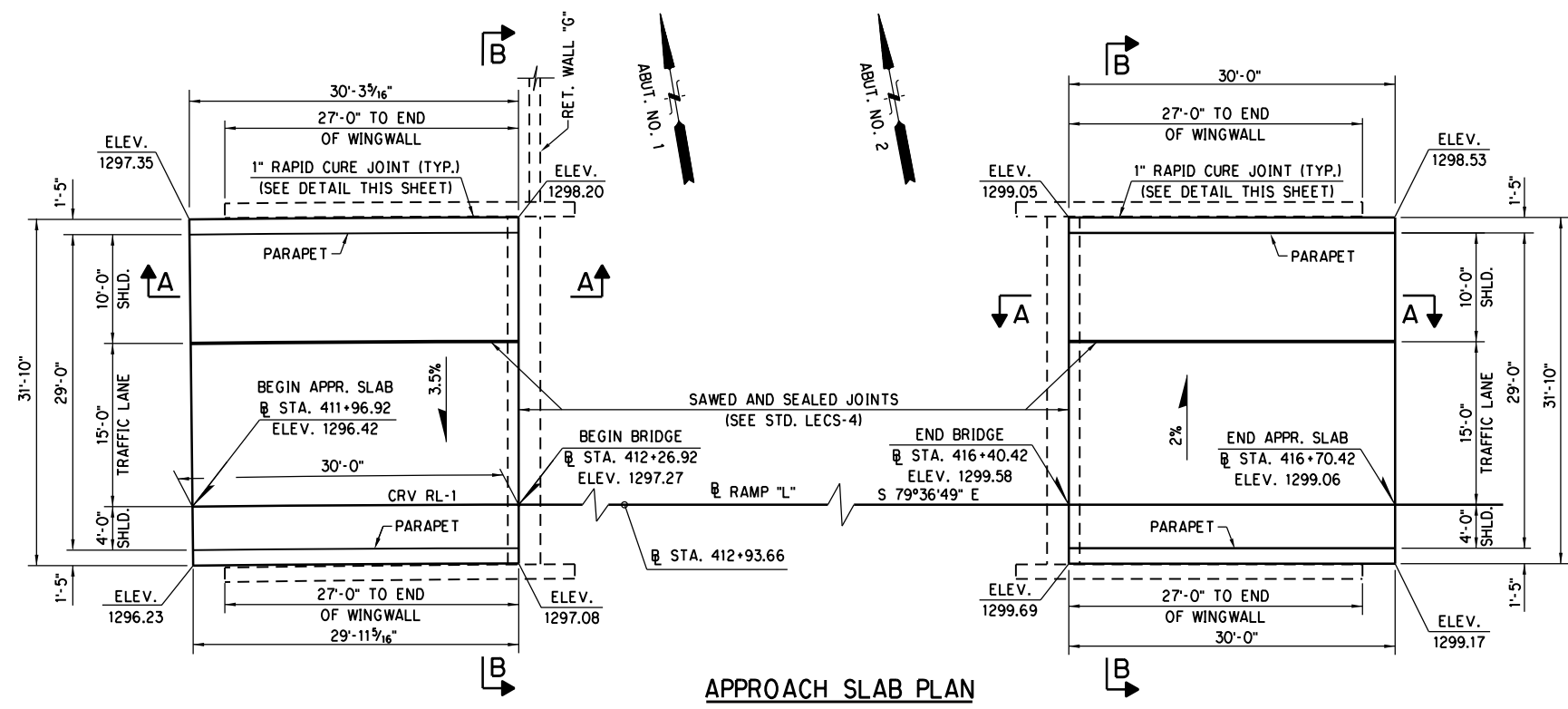

APPROACH SLAB PLAN

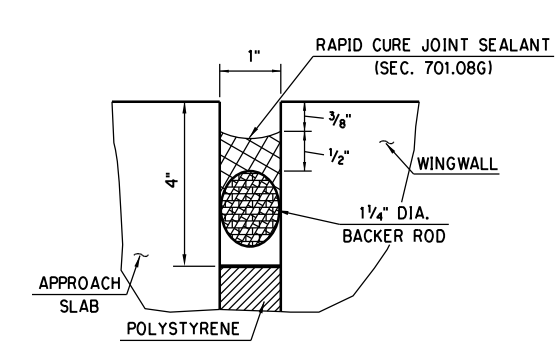

DETAIL OF RAPID CURE JOINT AT ABUT WINGWALL

FOR BACKER ROD AND JOINT SEALER GENERAL NOTES REFER TO STD. LECS-4.

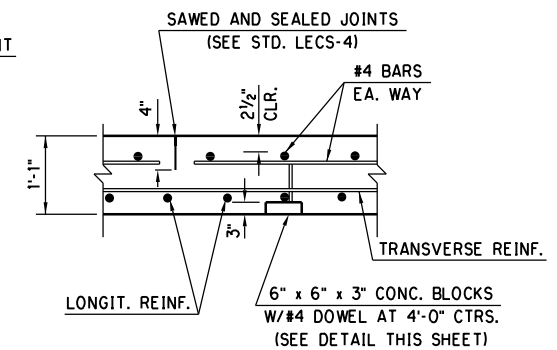

DETAIL OF SAWED JOINT AND DOWEL BLOCK

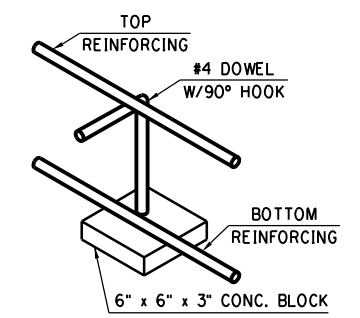

DOWEL BLOCK

NOTE: CONTRACTOR MAY USE APPROVED HIGH CHAIRS WITH SAND PLATES (HCP) AND 6" x 6" x 3" PLAIN CONCRETE BLOCKS IN LIEU OF DOWEL BLOCKS SHOWN. SPACING SHALL BE 4'-0" MAX. ON CTRS.

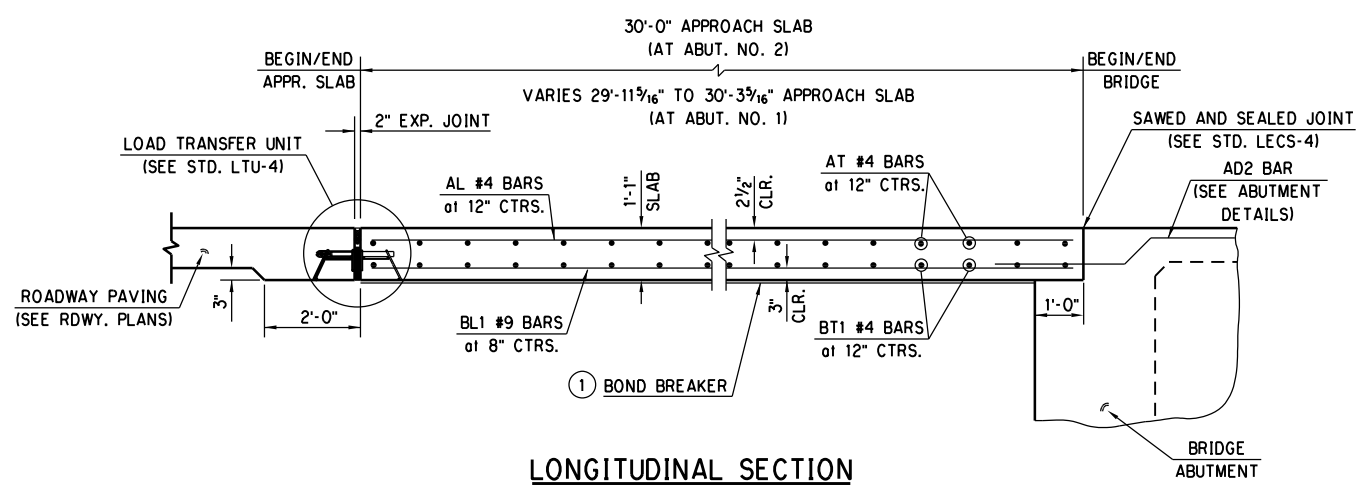

LONGITUDINAL SECTION SECTION A - A

NOTE: DO NOT TIE WITHIN 6" OF THE JOINT BETWEEN THE APPROACH SLAB AND BRIDGE DECK OR WITHIN 6" OF THE SAWED JOINTS OR THE JOINTS BETWEEN THE APPROACH SLAB AND THE WINGWALLS.

① BOND BREAKER SHALL BE ONE 6 ML OR TWO 4 MIL POLYETHYLENE SHEETS.

NOTE: FOR DETAILS OF PARAPET SEE ODOT STD. FSHP-42-2

QUANTITIES				
ITEM	UNIT	ABUT. 1	ABUT. 2	TOTAL
APPROACH SLAB	S.Y.	106.60	106.10	212.70
42" F-SHAPED PARAPET	L.F.	60.30	60.00	120.30
WATER REPELLENT (VISUALLY INSPECTED)	L.F.	29.00	29.00	58.00

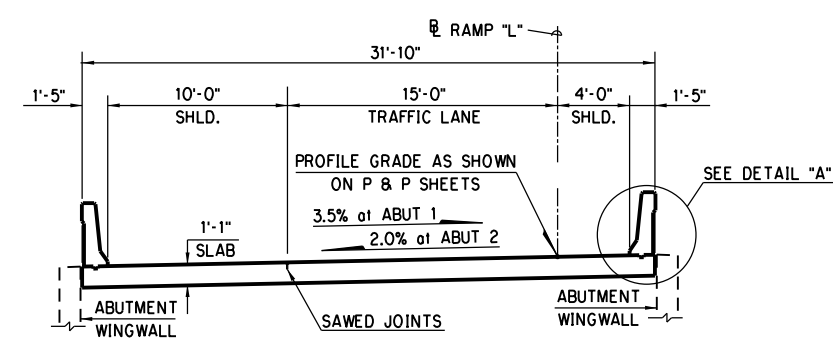

TYPICAL SECTION SECTION B - B

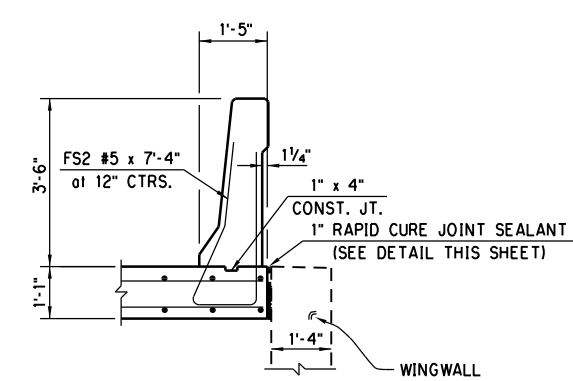

DETAIL "A"

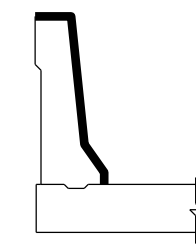

WATER REPELLENT SURFACE TREATMENT

SURFACES INDICATED WITH HEAVY LINES SHALL BE TREATED WITH A PENETRATING WATER REPELLENT SURFACE TREATMENT.

NOTES:

CONCRETE FOR APPROACH SLABS SHALL BE CLASS AA. REINFORCING STEEL SHALL BE GRADE 60.

ALL COST OF MATERIALS, LABOR, AND INCIDENTALS NECESSARY TO COMPLETE THE WORK AS SHOWN SHALL BE INCLUDED IN THE UNIT PRICE BID PER SQUARE YARD OF APPROACH SLAB. THIS PRICE BID SHALL INCLUDE THE COST OF LOAD TRANSFER UNIT, POLYSTYRENE, RAPID CURE JOINT SEALANT, BACKER RODS, SAWING, DOWEL BLOCKS, POLYETHYLENE SHEETING, CLASS AA CONCRETE AND EPOXY COATED REINFORCING STEEL (INCLUDING FS2 PARAPET BARS).

ALL COST OF PARAPET SHALL BE INCLUDED IN PRICE BID PER L.F. OF "42" F-SHAPED PARAPET". THIS PRICE SHALL INCLUDE COST OF ALL FS1, FH1 AND FH2 EPOXY COATED REINFORCING STEEL. PARAPET SHALL BE FULL HEIGHT FOR THE LENGTH OF THE APPROACH SLAB.

DESIGN		PHASE 4	OKLAHOMA COUNTY
DRAWN		BRIDGE "L"	RAMP "L" OVER RAMP "A"
CHECKED		APPROACH SLAB DETAILS (SHEET 1 OF 2)	
APPROVED			
SQUAD	POE	STATE JOB NO. 090321081 SHEET NO. B156	

3/1/2024 10:36:06 AM H:\PROJECTS\2789_Crossroads_Phase 4\Bridges\Drawings\Ph4 Bridges\Bridges L\0903208 P4 Br L Appr.dgn

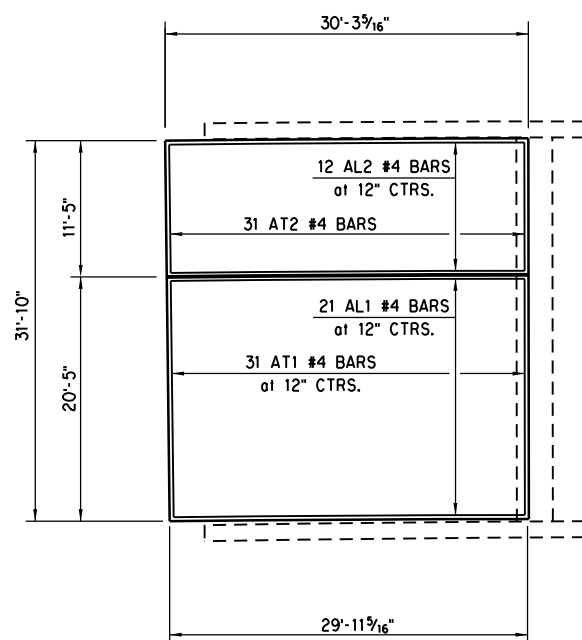

AT ABUT NO. 1

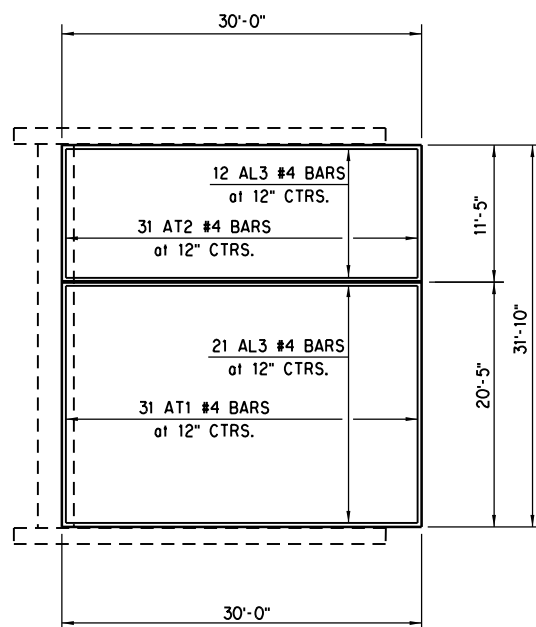

AT ABUT NO. 2

TOP MAT REINFORCING PLAN

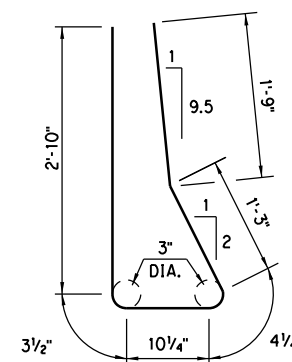

FS2 #5 x 7'-4"

NOTE: FS2 BARS SHALL BE TIED IN PLACE BEFORE POURING THE CONCRETE FOR THE APPROACH SLAB.

NOTE: ALL BENT BAR DIMENSIONS ARE OUT TO OUT.

BAR LIST - ABUT. NO. 1 (EPOXY COATED) (FOR INFORMATION ONLY)						
MARK	NO.	SIZE	FORM	SPACING	LENGTH	VARIABLE LENGTH
AL1	21	#4	STR.	12" C/C	29'-8 1/2" AVG.	29'-7" TO 29'-10"
AL2	12	#4	STR.	12" C/C	29'-10 1/2" AVG.	29'-10" TO 29'-11"
AT1	31	#4	STR.	12" C/C	20'-1"	--
AT2	31	#4	STR.	12" C/C	11'-2"	--
BL1	48	#9	STR.	8" C/C	29'-9" AVG.	29'-7" TO 29'-11"
BT1	31	#4	STR.	12" C/C	31'-6"	--
FS2	62	#5	BNT.	12 C/C	7'-4"	--

BAR LIST - ABUT. NO. 2 (EPOXY COATED) (FOR INFORMATION ONLY)					
MARK	NO.	SIZE	FORM	SPACING	LENGTH
AL3	33	#4	STR.	12" C/C	29'-8"
AT1	31	#4	STR.	12" C/C	20'-1"
AT2	31	#4	STR.	12" C/C	11'-1"
BL2	49	#9	STR.	8" C/C	29'-8"
BT1	31	#4	STR.	12" C/C	31'-6"
FS2	62	#5	BNT.	12 C/C	7'-4"

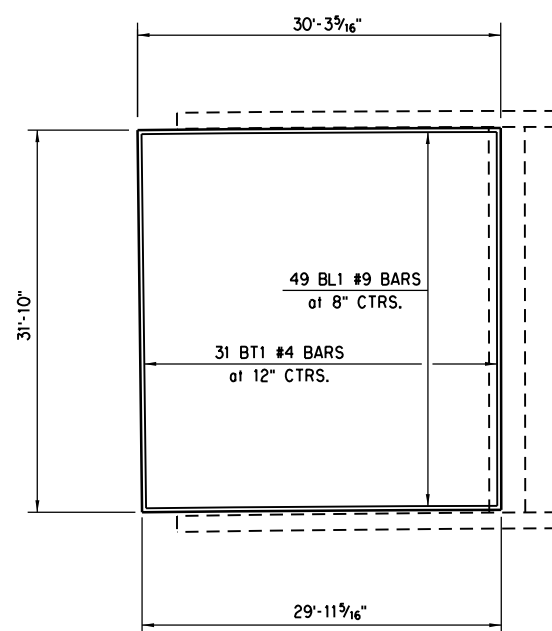

AT ABUT NO. 1

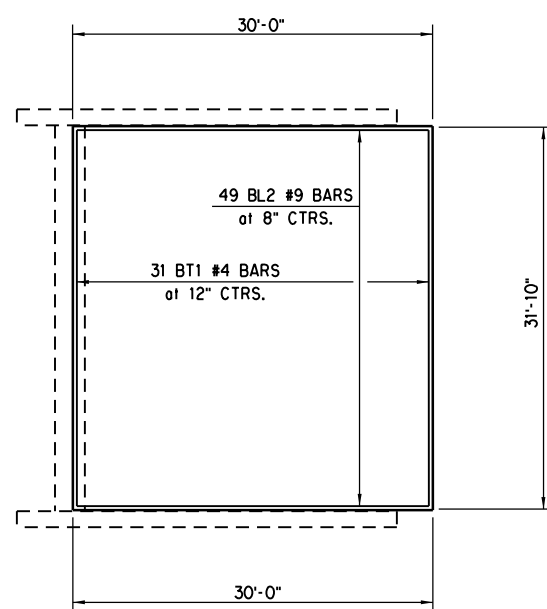

AT ABUT NO. 2

BOTTOM MAT REINFORCING PLAN

DESIGN		PHASE 4	OKLAHOMA COUNTY
DRAWN		BRIDGE "L"	RAMP "L" OVER RAMP "A"
CHECKED		<p>APPROACH SLAB DETAILS (SHEET 2 OF 2)</p>	
APPROVED			
SQUAD	POE	STATE JOB NO. 09032108	SHEET NO. B157

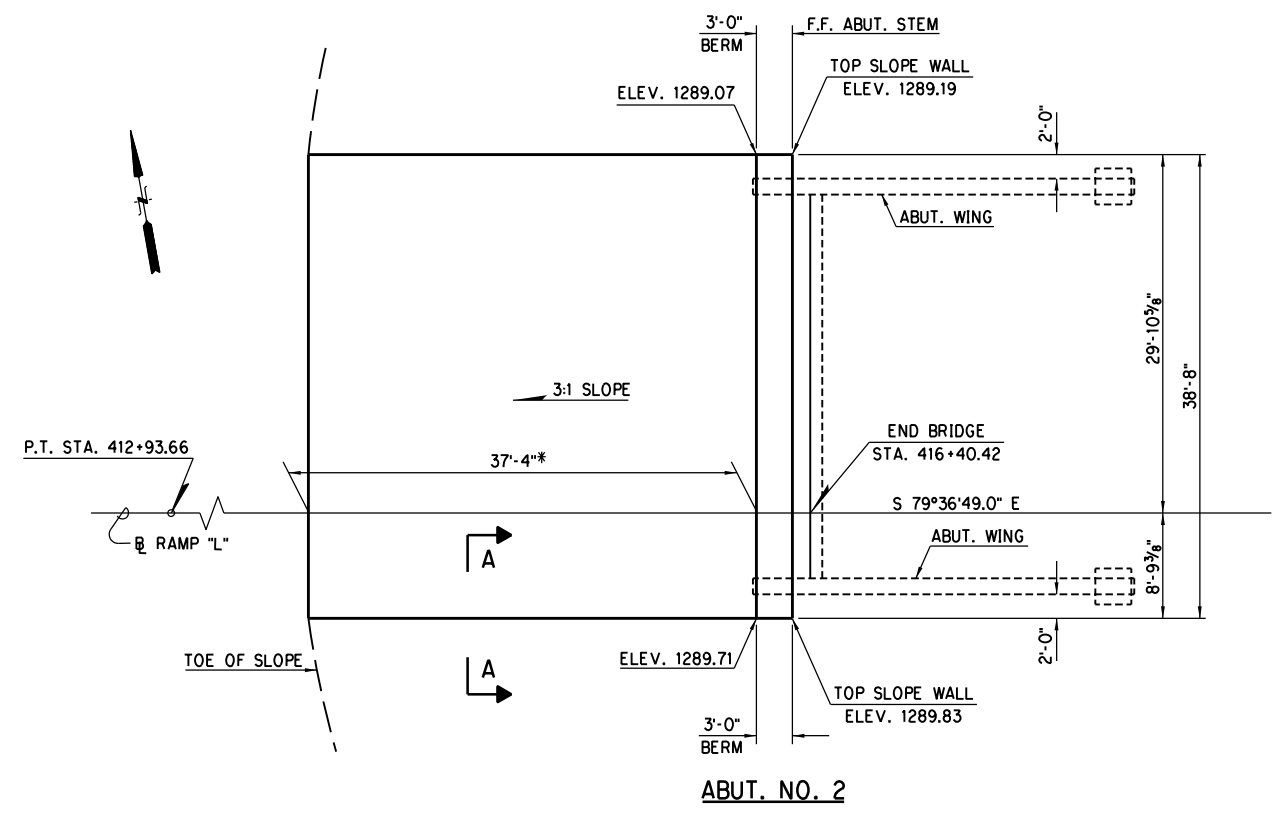

CLASS A CONCRETE:
ALL CONCRETE IN THE SLOPEWALL SHALL BE CLASS A CONCRETE AND SHALL BE POURED IN THE DRY. ALL CONSTRUCTION SHALL BE IN ACCORDANCE WITH SECTION 510 AND 610 OF THE STANDARD SPECIFICATIONS. COARSE AGGREGATE FOR THIN SECTION CONCRETE (701.06) MAY BE USED.

SLOPEWALL NOTES:

1. ALL CONCRETE IN THE SLOPEWALL SHALL BE CLASS A CONCRETE AND SHALL BE POURED IN THE DRY. ALL CONSTRUCTION SHALL BE IN ACCORDANCE WITH SECTIONS 509 AND 610 OF THE STANDARD SPECIFICATIONS.
2. NO HORIZONTAL CONSTRUCTION JOINTS WILL BE PERMITTED IN THE SLOPE WALL. FINAL NUMBER AND LOCATION OF VERTICAL CONSTRUCTION JOINTS WILL BE DETERMINED IN THE FIELD BY THE ENGINEER.
3. SURFACE AREA OF TOE AND EDGES OF SLOPE WALL INCLUDED IN PAY QUANTITY SHOWN.
4. ALL COSTS OF THE JOINT SEALER AND FILLER, REINFORCING STEEL, CONCRETE, EXCAVATION, LABOR, FORMS AND INCIDENTALS NECESSARY TO COMPLETE THE WORK AS SHOWN, SHALL BE INCLUDED IN THE CONTRACT PRICE BID FOR SLOPEWALL (5').
5. ALL COST OF FILTER SAND, COARSE PIPE UNDERDRAIN COVER MATERIAL, EXCAVATION, LABOR AND INCIDENTALS NECESSARY TO COMPLETE THE WORK AS SHOWN, SHALL BE INCLUDED IN THE CONTRACT PRICE BID FOR 6" PERFORATED PIPE UNDERDRAIN ROUND.
6. NON-PERFORATED PIPE SHALL BE CONNECTED TO PERFORATED SLOPE WALL PIPE, EXTENDED, AS DIRECTED IN THE FIELD BY THE ENGINEER.

SLOPE WALL PLAN

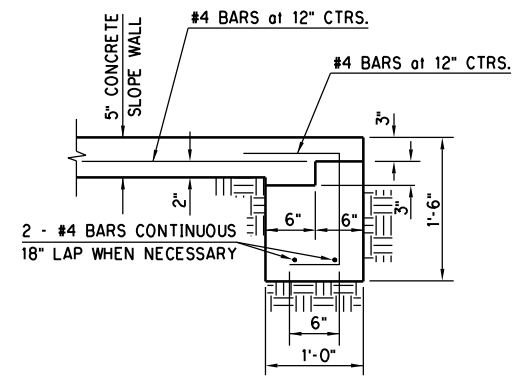

* NOTE: DIMENSIONS INDICATED ARE APPROXIMATE. ACTUAL EXTENT OF SLOPE WALLS SHALL BE SET IN THE FIELD.

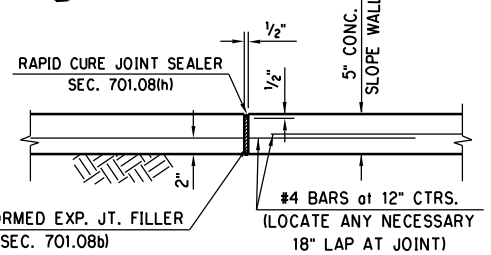
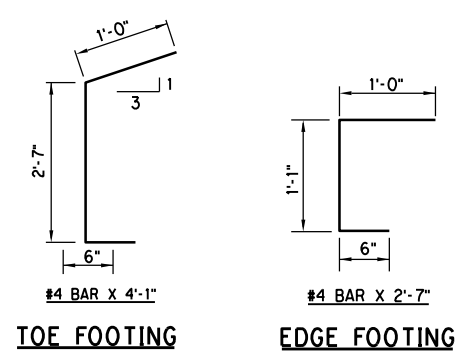
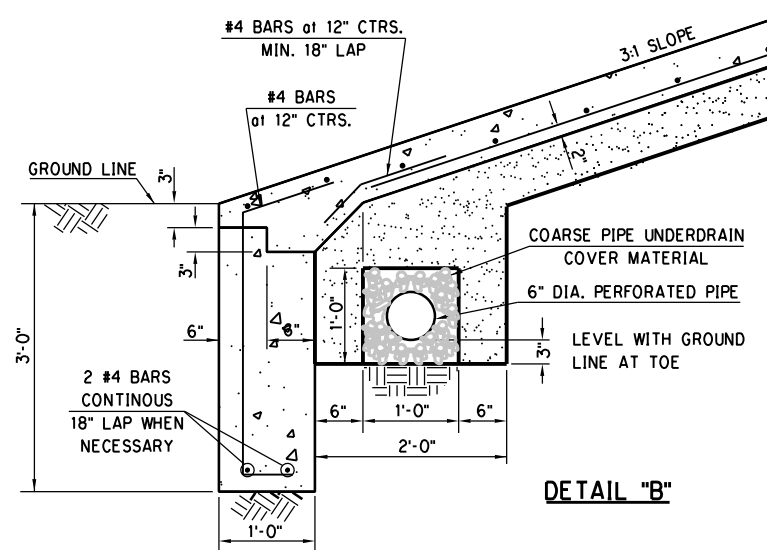
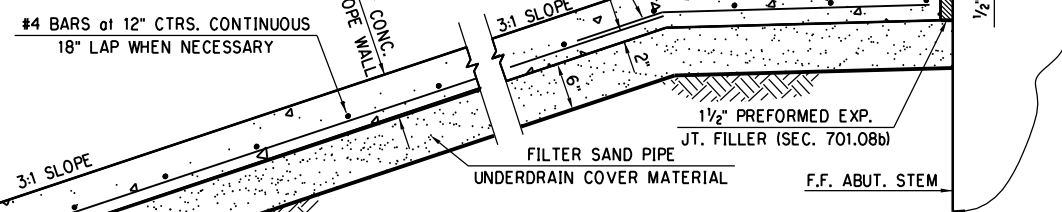
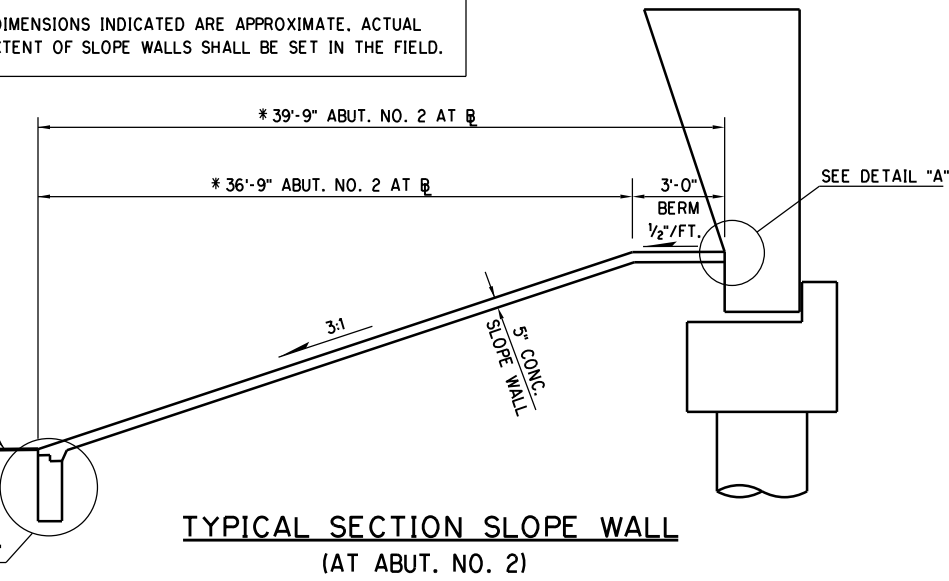
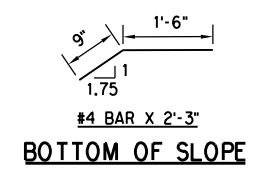
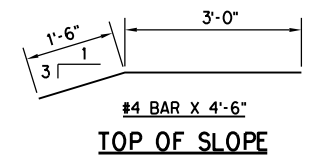

QUANTITIES		
ITEM	UNIT	ABUT. 2
SLOPE WALL (5")	S.Y.	262.00
6" PERFORATED PIPE UNDERDRAIN ROUND	L.F.	38.70
6" NON-PERF. PIPE UNDERDRAIN RND.	L.F.	20.00

① NON-PERFORATED PIPE SHALL BE CONNECTED TO PERFORATED PIPE AND

CONSTRUCTION JOINTS:
NO HORIZONTAL CONSTRUCTION JOINTS WILL BE PERMITTED IN THE SLOPEWALL. FINAL NUMBER AND LOCATION OF THE VERTICAL CONSTRUCTION JOINTS WILL BE DETERMINED IN THE FIELD BY THE RESIDENT ENGINEER. JOINTS WILL HAVE A MAXIMUM SPACING OF 10'-0" MEASURED ALONG THE TOP OF THE SLOPEWALL.

PHASE 4
BRIDGE "L" RAMP "L" OVER RAMP "A"

OKLAHOMA COUNTY

SLOPE WALL DETAILS

STATE JOB NO. 09032(08) SHEET NO. B158

DESIGN	
DRAWN	
CHECKED	
APPROVED	
SQUAD	POE

3/1/2024 10:36:09 AM H:\PROJECTS\2789_CrossRoads_Phase_4\Bridges\Drawings\Ph4 Bridges\Drawings\0903208 P4 Br L Slope.dgn

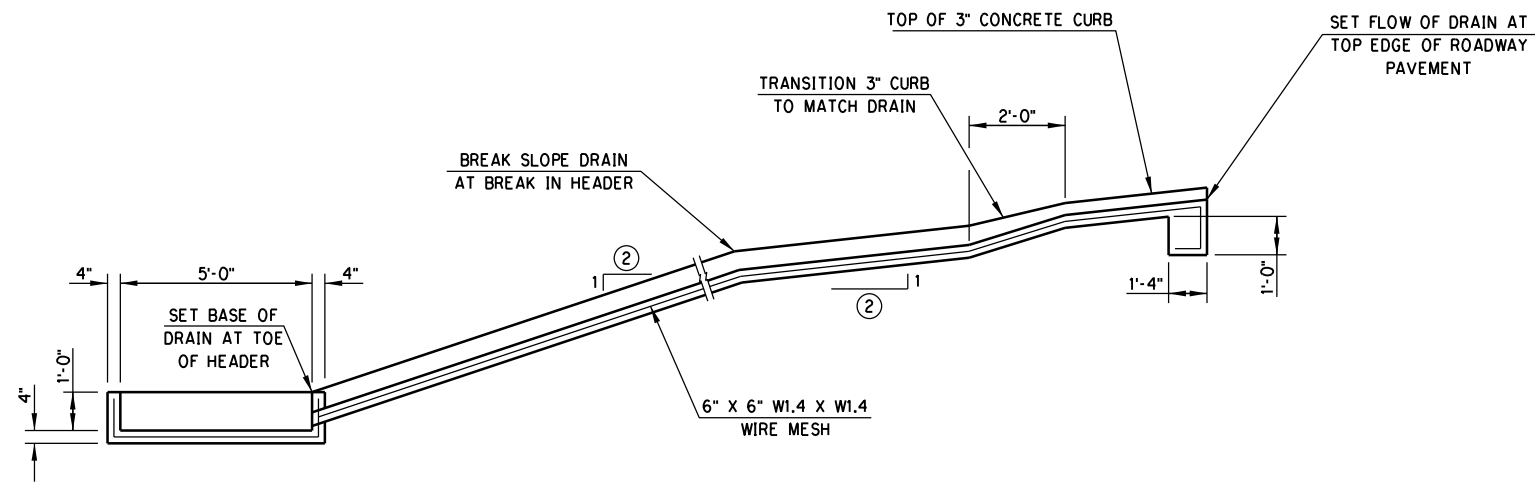

SECTION B-B
② SLOPE TO MATCH SLOPE OF HEADER

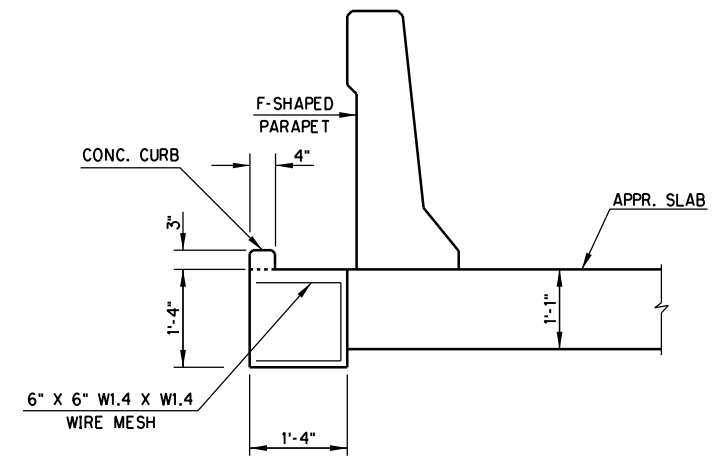

SECTION A-A

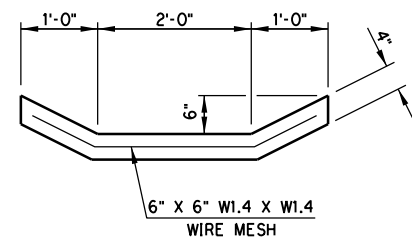

SECTION C-C

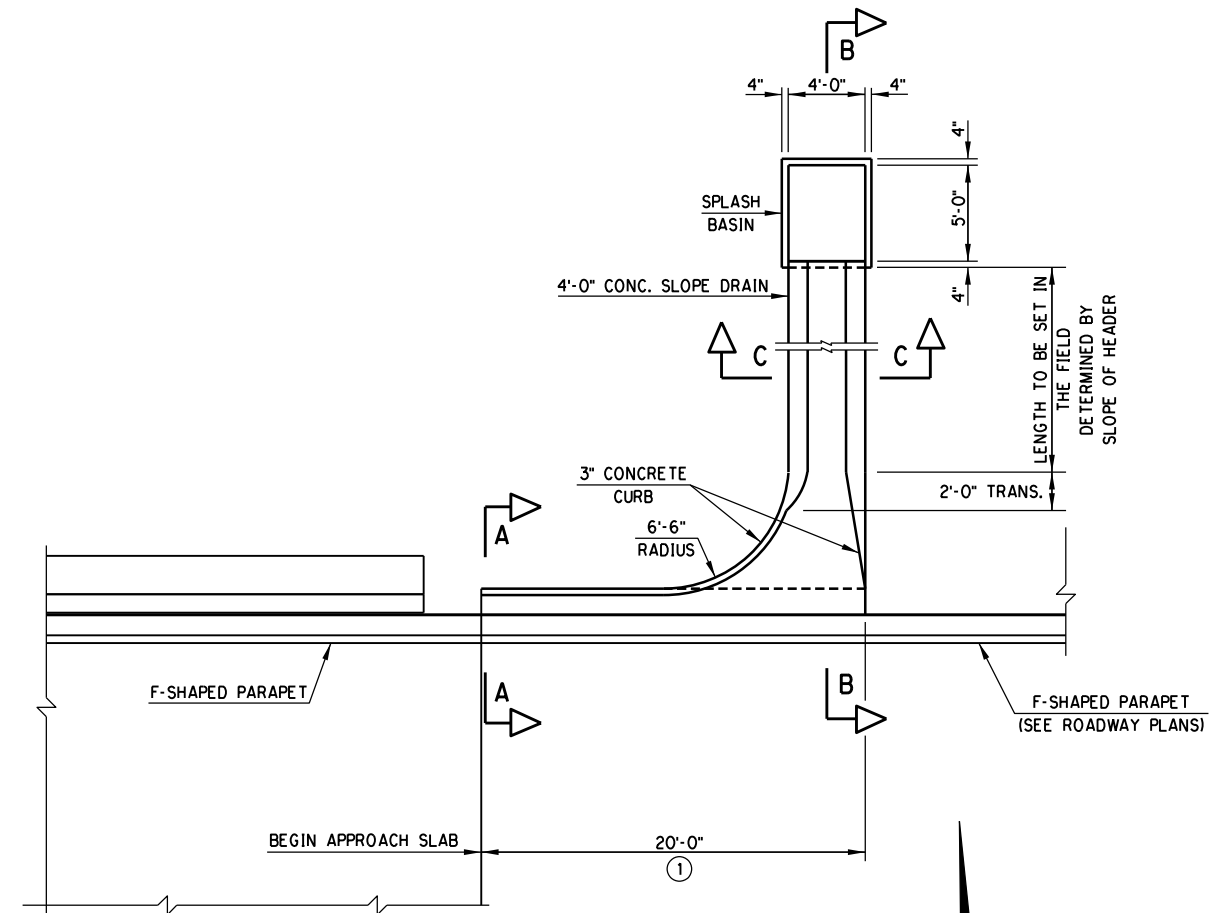

SLOPE DRAIN PLAN
ABUT. NO. 2

① ACTUAL LOCATION OF DRAIN TO BE SET IN THE FIELD.

NOTE:
SLOPE DRAIN AND CURBS SHALL BE CONSTRUCTED USING CLASS "C" CONCRETE AS SHOWN ON THIS SHEET. ALL COSTS OF EXCAVATION, SLOPE DRAINS, CURBS, AND REINFORCING STEEL SHALL BE INCLUDED IN THE PAY ITEM FOR "CLASS "C" CONCRETE".

DESIGN	
DRAWN	
CHECKED	
APPROVED	
SQUAD	POE

PHASE 4
OKLAHOMA COUNTY
BRIDGE "L"
RAMP "L" OVER 1-35

**DRAIN AT END OF
BRIDGE DETAILS**

STATE JOB NO. 09032(08) SHEET NO. B159

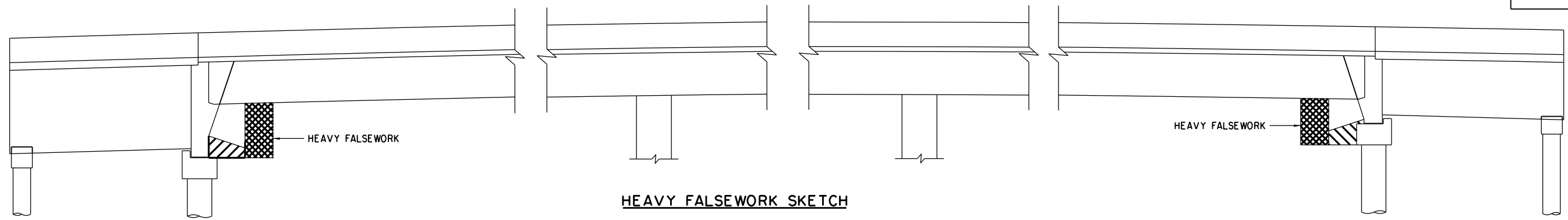

HEAVY FALSEWORK SKETCH

HEAVY FALSEWORK AT ABUTMENTS SHALL NOT BE SUPPORTED BY THE ABUTMENT FOOTING. THE AREA IN FRONT OF THE ABUTMENT WALL DOWN TO THE TOP OF THE FOOTING ELEVATION MUST REMAIN EXCAVATED UNTIL AFTER ALL PRESTRESSING IS COMPLETED.

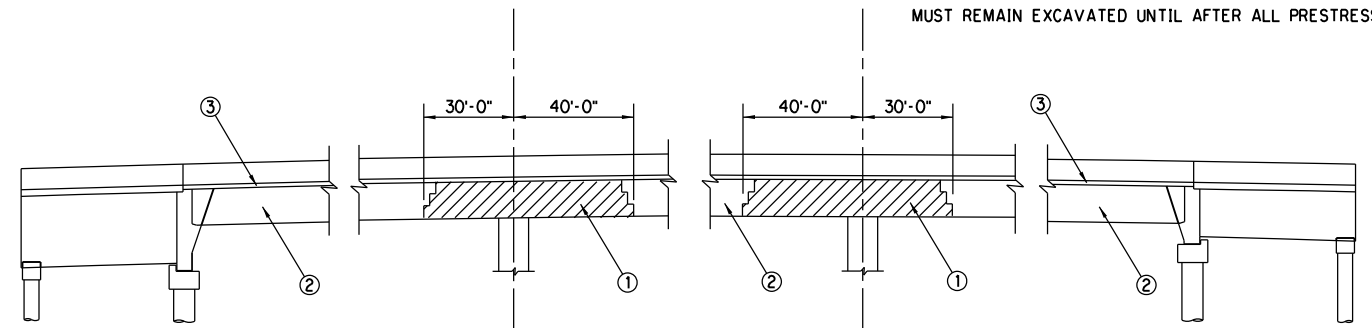

SUPERSTRUCTURE PLACING SEQUENCE

- ① BOTTOM SLAB, WEBS, AND PIER CAP FOR SECTIONS OVER PIERS.
 - ② BOTTOM SLAB, WEBS, ABUTMENT DIAPHRAGMS FOR END SECTIONS AND CENTER SPAN.
 - ③ TOP SLAB. NO CONSTRUCTION JOINTS WILL BE PERMITTED WITHIN SECTION ① AREAS.
- NOTE: BACKFILL AT ABUTMENTS AND CONSTRUCTION OF ABUTMENT WINGS AND PARAPETS SHALL BE DONE AFTER STRUCTURE HAS BEEN PRESTRESSED AND FALSEWORK REMOVED.

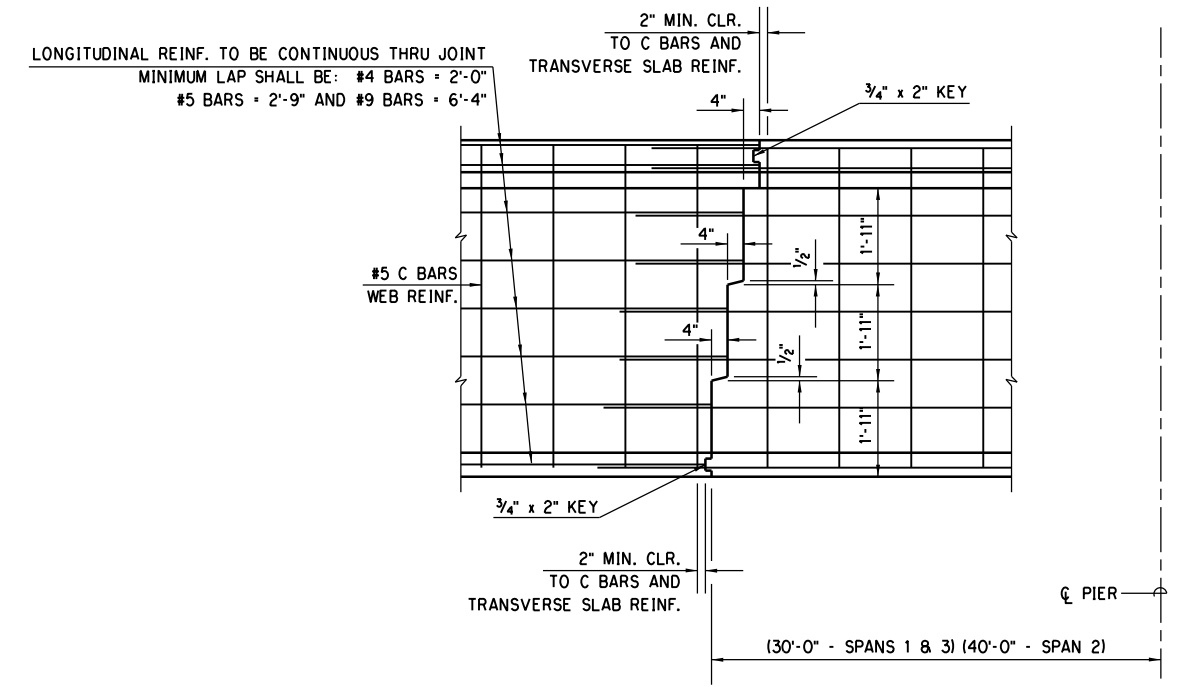

TRANSVERSE GIRDER CONSTRUCTION JOINT

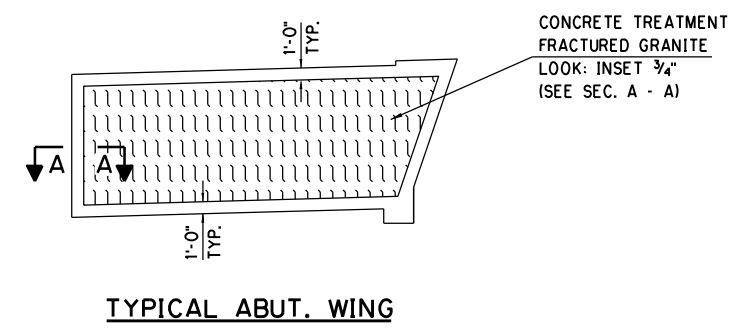

TYPICAL ABUT. WING

ARCHITECTURAL TREATMENT DETAILS

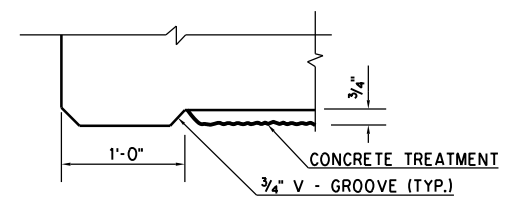

SECTION A - A

AREA OF CONCRETE TREATMENT:

- ABUTS. 1 AND 2 --- S.Y.
- PIERS 1 AND 2 --- S.Y.
- TOTAL --- S.Y.

THESE AREAS ARE APPROXIMATE AND FOR INFORMATION PURPOSES ONLY.

CONCRETE SURFACES OF ABUTMENTS AND SHALL HAVE A TEXTURED APPEARANCE AS INDICATED ON THE PLANS.

THE TEXTURED SURFACES WILL HAVE A 3/4" VERTICAL RELIEF, "FRACTURED GRANITE" OR "RANDOM SPLIT FACE ROCK" APPEARANCE AS PRODUCED BY USING FORM LINERS MANUFACTURED BY SYMONS CORPORATION (FRACTURED GRANITE), OR L.M. SCOFIELD COMPANY (RANDOM SPLIT FACE ROCK).

THE FORM LINING MATERIAL SHALL BE FULL SIZED COMMERCIAL PANELS, AND JOINTS SHALL BE LINED UP, IN SO FAR AS IS PRACTICAL, NO SCRAP OR ODD SIZED PIECES WILL BE USED. PROVISIONS WILL BE MADE IN ADJUSTMENT OF FORMS TO CORRECT ANY DEFORMATIONS. FORM LINERS MUST BE SEALED AT ALL ENDS, EDGES, JOINTS, AND TIE HOLES TO PREVENT DISCOLORATION, SANDSTREAKING AND FINS ON CONCRETE SURFACES. ALL CHAMFER STRIPS MUST BE WELL OILED TO FACILITATE STRIPPING. AS SOON AS FORMS ARE REMOVED, ALL DISCONTINUITY OF RELIEF PATTERN SHALL BE DRESSED IN A MANNER APPROVED BY THE ENGINEER.

THE CONTRACTOR WILL FURNISH THE BRIDGE ENGINEER WITH A 12" x 18" SAMPLE PANEL FINISHED IN THE MANNER THE CONCRETE WALL TREATMENT IS TO BE FINISHED FOR APPROVAL.

ALL COST OF CONCRETE WALL TREATMENT INCLUDING FINISHING, FORM LINERS, LABOR, MATERIALS, TOOLS, AND INCIDENTALS NECESSARY TO COMPLETE THE WORK AS SPECIFIED SHALL BE INCLUDED IN OTHER ITEMS OF WORK.

PHASE 4		OKLAHOMA COUNTY	
BRIDGE "L"		RAMP "L" OVER RAMP "A"	
DESIGN		ARCHITECTURAL TREATMENT DETAILS AND SUPERSTR. PLACING SEQUENCE STATE JOB NO. 09032(08) SHEET NO. B160	
DRAWN			
CHECKED			
APPROVED			
SQUAD	POE		

3/1/2024 10:36:42 AM H:\PROJECTS\2789_CrossRoads_Phase 4\Bridges\Drawings\Ph4 Bridges\Bridges L\0903208 P4 Br L Pour Arch.dgn

STORM WATER MANAGEMENT PLAN

SITE DESCRIPTION

PROJECT LIMITS: I-240/I-35 INTERCHANGE RECONSTRUCTION - PHASE 4

PROJECT DESCRIPTION: GRADING, DRAINAGE, SURFACING AND BRIDGE PLANS

SUGGESTED SEQUENCE OF EROSION CONTROL ACTIVITIES: _____

PRIOR TO INITIATING SOIL DISTURBING ACTIVITIES, THE CONTRACTOR WILL INSTALL ALL PERIMETER TEMPORARY SEDIMENT CONTROLS SPECIFIED. STRIP, STOCKPILE AND STABILIZE TOPSOIL. CLEAR AND GRUB ONLY IN NECESSARY AREAS. PRESERVING AS MUCH NATIVE VEGETATION AS POSSIBLE. INSTALL, MAINTAIN AND/OR MOVE TEMPORARY SEDIMENT ITEMS WITH CONSTRUCTION OPERATIONS AS PRACTICAL. IF DIRECTED BY THE ENGINEER, PLANT TEMPORARY SEEDING. REPLACE SALVAGED TOPSOIL AND DEVICES WHEN AN ACCEPTABLE VEGETATIVE COVER (AT LEAST 70%) HAS BEEN ATTAINED. AS SITE CONDITIONS WARRANT, THE CONTRACTOR MAY CHOOSE TO MODIFY THE TYPE OR ARRANGEMENT OF SPECIFIED PRACTICES TO IMPROVE THEIR EFFECTIVENESS AS APPROVED BY THE ENGINEER. THE CONTRACTOR WILL MAINTAIN A LOG OF THE DATES OF MAJOR SOIL DISTURBANCE ACTIVITIES, AND ALSO THE DATES OF INSTALLATION OF EROSION CONTROL MEASURES.

SOIL TYPE: SANDY LOAM

TOTAL AREA OF THE CONSTRUCTION SITE: 96 ACRES

ESTIMATED AREA TO BE DISTURBED: 37 ACRES

OFFSITE AREA TO BE DISTURBED: (FOR CONTRACTOR USE) _____

TOTAL IMPERVIOUS AREA PRE-CONSTRUCTION: 38 ACRES

TOTAL IMPERVIOUS AREA POST-CONSTRUCTION: 38 ACRES

POST-CONSTRUCTION RUNOFF COEFFICIENT OF THE SITE: 0.78

LATITUDE & LONGITUDE OF CENTER OF PROJECT: 35°23'30.40" N 97°29'42.27" W

PROJECT WILL DISCHARGE TO:

NAME OF RECEIVING WATERS: UNNAMED TRIBUTARY OF LIGHTNING CREEK

SENSITIVE WATERS OR WATERSHEDS: YES NO

303(d) IMPAIRED WATERS: YES NO

IF YES, LIST IMPAIRMENT: N/A

LOCATED IN A TMDL: YES NO

LAKE THUNDERBIRD TMDL: YES NO

MS4 ENTITY: YES NO

IF YES, LOCATION: CITY OF OKLAHOMA CITY

NOTE:
THIS SHEET SHOULD BE USED IN CONJUNCTION WITH A DRAINAGE MAP THAT ILLUSTRATES THE DRAINAGE PATTERNS/PATHWAYS AND RECEIVING WATERS FOR THIS PROJECT. THIS SHEET SHOULD ALSO BE USED WITH THE EROSION CONTROL SUMMARIES, PAY ITEMS, & NOTES.

EROSION AND SEDIMENT CONTROLS

SOIL STABILIZATION PRACTICES:

- TEMPORARY SEEDING
- PERMANENT SODDING, SPRIGGING OR SEEDING
- VEGETATIVE MULCHING
- SOIL RETENTION BLANKET
- PRESERVATION OF EXISTING VEGETATION

NOTE: TEMPORARY EROSION CONTROL METHODS MUST BE USED ON ALL DISTURBED AREAS WHERE CONSTRUCTION ACTIVITIES HAVE CEASED FOR OVER 14 DAYS. METHODS USED WILL BE AS SHOWN ON PLANS, OR AS DIRECTED BY THE ENGINEER.

STRUCTURAL PRACTICES:

- STABILIZED CONSTRUCTION EXIT
- TEMPORARY SILT FENCE
- TEMPORARY SILT DIKES
- TEMPORARY FIBER LOG
- DIVERSION, INTERCEPTOR OR PERIMETER DIKES
- DIVERSION, INTERCEPTOR OR PERIMETER SWALES
- ROCK FILTER DAMS
- TEMPORARY SLOPE DRAIN
- PAVED DITCH W/ DITCH LINER PROTECTION
- TEMPORARY DIVERSION CHANNELS
- TEMPORARY SEDIMENT BASINS
- TEMPORARY SEDIMENT TRAPS
- TEMPORARY SEDIMENT FILTERS
- TEMPORARY SEDIMENT REMOVAL
- RIP RAP
- INLET SEDIMENT FILTER
- TEMPORARY BRUSH SEDIMENT BARRIERS
- SANDBAG BERMS
- TEMPORARY STREAM CROSSINGS

OFFSITE VEHICLE TRACKING:

- HAUL ROADS DAMPENED FOR DUST CONTROL
- LOADED HAUL TRUCKS TO BE COVERED WITH TARPULIN
- EXCESS DIRT ON ROAD REMOVED DAILY

NOTES:

THE CONTRACTOR SHALL ALSO BE RESPONSIBLE FOR THE FOLLOWING:

MAINTENANCE AND INSPECTION:

ALL EROSION AND SEDIMENT CONTROLS WILL BE MAINTAINED IN GOOD WORKING ORDER FROM THE BEGINNING OF CONSTRUCTION UNTIL AN ACCEPTABLE VEGETATIVE COVER IS ESTABLISHED. INSPECTION BY THE CONTRACTOR AND ANY NECESSARY REPAIRS SHALL BE PERFORMED ONCE EVERY 7 CALENDAR DAYS AND WITHIN 24 HOURS AFTER ANY STORM EVENT GREATER THAN 0.5 INCH AS RECORDED BY A NON-FREEZING RAIN GAUGE TO BE LOCATED ON SITE. POTENTIALLY ERODIBLE AREAS, DRAINAGEWAYS, MATERIAL STORAGE, STRUCTURAL DEVICES, CONSTRUCTION ENTRANCES AND EXITS ALONG WITH EROSION AND SEDIMENT CONTROL LOCATIONS ARE EXAMPLES OF SITES THAT NEED TO BE INSPECTED.

WASTE MATERIALS:

PROPER MANAGEMENT AND DISPOSAL OF CONSTRUCTION WASTE MATERIAL IS REQUIRED BY THE CONTRACTOR. MATERIALS INCLUDE STOCKPILES, SURPLUS, DEBRIS AND ALL OTHER BY-PRODUCTS FROM THE CONSTRUCTION PROCESS. PRACTICES INCLUDE DISPOSAL, PROPER MATERIALS HANDLING, SPILL PREVENTION AND CLEANUP MEASURES. CONTROLS AND PRACTICES SHALL MEET THE REQUIREMENTS OF ALL FEDERAL, STATE AND LOCAL AGENCIES.

HAZARDOUS MATERIALS:

PROPER MANAGEMENT AND DISPOSAL OF HAZARDOUS WASTE MATERIALS IS REQUIRED. THE CONTRACTOR IS RESPONSIBLE FOR FOLLOWING MANUFACTURER'S RECOMMENDATIONS, STATE AND FEDERAL REGULATIONS TO ENSURE CORRECT HANDLING, DISPOSAL, SPILL PREVENTION AND CLEANUP MEASURES. EXAMPLES INCLUDE BUT ARE NOT LIMITED TO: PAINTS, ACIDS, CLEANING SOLVENTS, CHEMICAL ADDITIVES, CONCRETE CURING COMPOUNDS AND CONTAMINATED SOILS.

GENERAL NOTES:

A STORM WATER POLLUTION PREVENTION PLAN (SWPPP) IS REQUIRED TO COMPLY WITH THE OKLAHOMA POLLUTION DISCHARGE ELIMINATION SYSTEM (OPDES) REGULATIONS. THIS PLAN IS INITIATED DURING THE DESIGN PHASE, CONFIRMED IN THE PRE-WORK MEETINGS AND AVAILABLE ON THE JOB SITE ALONG WITH COPIES OF THE NOTICE OF INTENT (NOI) FORM AND PERMIT CERTIFICATE THAT HAVE BEEN FILED WITH THE OKLAHOMA DEPARTMENT OF ENVIRONMENTAL QUALITY (ODEQ). THE PLAN MUST BE KEPT CURRENT WITH UP-TO-DATE AMENDMENTS DURING THE PROGRESSION OF THE PROJECT. ALL CONTRACTOR OFF-SITE OPERATIONS ASSOCIATED WITH THE PROJECT MUST BE DOCUMENTED IN THE SWPPP, I.E., BORROW PITS, WORK ROADS, DISPOSAL SITES, ASPHALT/CONCRETE PLANTS, ETC. THE BASIC GOAL OF STORM WATER MANAGEMENT IS TO IMPROVE WATER QUALITY BY REDUCING POLLUTANTS IN STORM WATER DISCHARGES. RUNOFF FROM CONSTRUCTION SITES HAS A POTENTIAL FOR POLLUTION DUE TO EXPOSED SOILS AND THE PRESENCE OF HAZARDOUS MATERIALS USED IN THE CONSTRUCTION PROCESS. THE PREVENTION OF SOIL EROSION, CONTAINMENT OF HAZARDOUS MATERIALS AND/OR THE INTERCEPTION OF THESE POLLUTANTS BEFORE LEAVING THE CONSTRUCTION SITE ARE THE BEST PRACTICES FOR CONTROLLING STORM WATER POLLUTION.

THE FOLLOWING SECTIONS OF THE 2019 ODOT STANDARD SPECIFICATIONS SHOULD BE NOTED:

- 103.05 BONDING REQUIREMENTS
- 104.10 FINAL CLEANING UP
- 104.12 CONTRACTOR'S RESPONSIBILITY FOR WORK
- 104.13 ENVIRONMENTAL PROTECTION
- 106.08 STORAGE AND HANDLING OF MATERIAL
- 107.01 LAWS, RULES AND REGULATIONS TO BE OBSERVED
- 107.20 STORM WATER MANAGEMENT
 - 220 MANAGEMENT OF EROSION, SEDIMENTATION, AND STORM WATER POLLUTION PREVENTION
 - 221 TEMPORARY SEDIMENT CONTROL

IN ADDITION:

"ODEQ GENERAL PERMIT (OKR10) FOR STORM WATER DISCHARGES FROM CONSTRUCTION ACTIVITIES WITHIN THE STATE OF OKLAHOMA." ODEQ, WATER QUALITY DIVISION, SEPTEMBER 13, 2017.

DESIGN			PHASE 4	OKLAHOMA COUNTY
DRAWN			STORM WATER MANAGEMENT PLAN	
CHECKED				
APPROVED				
SQUAD	POE			
			STATE JOB NO. <u>090321081</u>	SHEET NO. <u>R001</u>

90% PLAN SUBMITTAL

3/4/2024

DRAINAGE STRUCTURE DESIGN RECORD

Table with columns: STRUCTURE NO., STATION & LOCATION, DESCRIPTION, DESIGN, DESIGN YEAR, DRAINAGE AREA, ANTICIPATED LAND USE, AVG. SLOPE OF WATERSHED, RUNOFF COEFFICIENT (WEIGHTED), LENGTH OF OVERLAND FLOW, SLOPE OF OVERLAND, LENGTH OF CHANNEL FLOW, SLOPE OF CHANNEL, TIME OF CONCENTRATION, INTENSITY OF DESIGN YEAR "I" (RAINFALL), DESIGN YEAR DISCHARGE Qn, DESIGN DISCHARGE BYPASS Qbypass, TOTAL DISCHARGE IN CONDUIT Qtotal, SPREAD, DESIGN TAILWATER, TOP OF COVER OR GRATE, STRUCTURE FLOW LINE, OUTLET FLOW LINE, STRUCTURE SLOPE, MAXIMUM ALLOWABLE HEADWATER VELOCITY Vn, CONTROLLING HEADWATER, TYPE OF HYDRAULIC CONTROL.

3/4/2024 2:34:59 PM H:\PROJECTS\2789_Cr-osaRoads_Phase 4\Roadway\Drawings\0903208-Phase 4_DDR_Ldgn

PHASE 4 DRAINAGE STRUCTURE DESIGN RECORD (SHEET 1 OF 3) STATE JOB NO. 09032108 SHEET NO. R002

DRAINAGE STRUCTURE DESIGN RECORD

STRUCTURE NO.	STATION & LOCATION	DESCRIPTION	DESIGN	DESIGN YEAR	DRAINAGE AREA	ANTICIPATED LAND USE	Avg. Slope of Watershed	Runoff Coefficient (Weighted)	Length of Overland Flow	Slope of Overland	Length of Channel Flow	Slope of Channel	Time of Concentration	Intensity of Design Year "I" (Rainfall)	Design Year Discharge Q _N	Design Discharge Bypass Q _{BYPASS}	Total Discharge in Conduit Q _{TOTAL}	Spread	Design Tailwater	Top of Cover or Grate	Structure Flow Line	Outlet Flow Line	Structure Slope	Maximum Allowable Headwater	Flow Velocity V _N	Controlling Headwater	Type of Hydraulic Control
				N	ACRES		%	C	FT	%	FT	%	MIN.	INHR	CFS	CFS	CFS	FT	ELEV					%	ELEV	FT/SEC	ELEV
H15	BL RAMP H STA. 443+74.00 8.00' LT.	CONST. CI DES. 2(STD) W/ 18" X 3.69' LG. RCP TO STR. H14	CI-2, SPI-5, SPB-2, FHTCP-4	10	0.22	PV/PS	1.85	0.73	20	19.80	326	0.75	6.06	9.43	1.02	0.12	5.18	4.69		1290.99	1284.93	1284.83	2.71		8.55		
H16	BL RAMP H STA. 443+74.00 22.53' RT.	CONST. CI DES. 3(STD) W/ 27.69' LG. RCP TO STR. H15	CI-2, SPI-5, SPB-2, FHTCP-4	10	0.24	PV	0.84	0.85	21	0.43	300	0.87	7.62	8.91	1.24	0.16	4.16	11.62		1290.97	1285.07	1284.93	0.51		4.35		
H17	BL RAMP H STA. 445+62.00 14.35' LT.	CONST. 4.0' DIA. MH W/ 24" X 196.00' LG. RCP TO STR. H19	MJB-4, MFC-5, SPI-5, SPB-2, FHTCP-4	10													18.16			1288.75	1282.25	1278.04	2.15		10.80		
H18	BL RAMP H STA. 445+62.00 8.00' LT.	CONST. CI DES. 3(STD) W/ 18" X 3.69' LG. RCP TO STR. H17	CI-2, SPI-5, SPB-2, FHTCP-4	10	0.60	PV	1.69	0.75	113	1.80	108	1.59	9.28	8.42	3.06	0.52	3.06	5.20		1287.68	1282.85	1282.75	2.71		7.37		
H19	BL RAMP H STA. 447+62.00 14.40' LT.	CONST. 4.0' DIA. MH W/ 24" X 157.00' LG. RCP TO STR. H21	MJB-4, MFC-5, SPI-5, SPB-2, FHTCP-4	10													21.53			1284.55	1278.04	1273.18	3.10		12.93		
H20	BL RAMP H STA. 447+62.00 8.00' LT.	CONST. CI DES. 3(STD) W/ 18" X 3.74' LG. RCP TO STR. H19	CI-2, SPI-5, SPB-2, FHTCP-4	10	0.79	PV	2.41	0.70	113	2.89	189	2.13	9.12	8.46	3.37	0.69	3.37	5.20		1283.47	1278.64	1278.54	2.67		8.18		
H21	BL RAMP H STA. 449+23.00 15.50' LT.	CONST. 4.0' DIA. MH W/ 24" X 58.09' LG. RCP TO STR. WB32	MJB-4, MFC-5, SPI-5, SPB-2, FHTCP-4	10													24.64			1280.27	1273.18	1271.53	2.84		12.90		
H22	BL RAMP H STA. 449+23.00 9.49' LT.	CONST. CI DES. 3(STD) W/ 18" X 3.35' LG. RCP TO STR. H21	CI-2, SPI-5, SPB-2, FHTCP-4	10	0.73	PS/PV	2.87	0.65	103	2.92	152	2.83	9.23	8.43	3.11	0.63	3.11	5.04		1279.28	1273.78	1273.68	2.99		7.68		
H23	BL RAMP H STA. 435+00.00 15.00' LT.	CONST. 4.0' DIA. MH W/ 18" X 6.99' LG. RCP TO STR. H24	MJB-3, MFC-4, SPI-4, SPB-1, FHTCP-3	10													2.42			1289.93	1285.22	1285.16	0.86		4.57		
H24	BL RAMP H STA. 435+00.00 4.00' LT.	CONST. 4.0' DIA. MH W/ 18" X 55.54' LG. RCP TO STR. H11	MJB-3, MFC-4, SPI-4, SPB-1, FHTCP-3	10													5.28			1289.87	1285.16	1284.46	0.73		5.28		
H25	BL RAMP H STA. 436+50.00 4.00' LT.	CONST. 4.0' DIA. MH W/ 18" X 145.22' LG. RCP TO STR. H24	MJB-3, MFC-4, SPI-4, SPB-1, FHTCP-3	10													2.86			1290.84	1286.13	1285.16	0.67		4.37		
H26	BL RAMP H STA. 435+50.00 14.50' LT.	CONST. SMD TYPE 2 W/ 18" X 45.98' LG. RCP TO STR. H23	SMD-3, SPI-4, SPB-1, FHTCP-3	10	0.56	CM	1.70	0.70	86	0.62	327	1.99	9.64	6.32	2.47	0.05	2.42			1292.69	1290.13	1286.72	7.42		9.86		
H27	BL RAMP H STA. 439+40.00 25.77' LT.	CONST. SMD TYPE 2 W/ 18" X 32.63' LG. RCP TO STR. ENE29 (PHASE 1B)	SMD-3, SPI-4, SPB-1, FHTCP-3	50	0.03	CM	1.38	0.07	2	20.89	56	0.59	5.00	9.83	0.24		0.24	7.10		1299.03	1295.40	1295.36	0.12		2.73		
NNE4	CL NESR STA. 97+33.00	CONST. CI DES. 3(STD) W/ 18" X 9.37' LG. RCP TO	CI-2, SPI-5, SPB-2, FHTCP-4	10	0.46	PV	2.84	0.95	106	0.82	589	3.21	8.48	8.65	2.52	0.36	2.52	10.72		1289.89	1284.71	1284.60	1.17		5.47		

3/4/2024 2:35:09 PM H:\PROJECTS\2789_CrossRoads_Phase 4\Roadway\Drawings\0903208-Phase 4_DDR_3.dgn

DESIGN	-	-	PHASE 4 DRAINAGE STRUCTURE DESIGN RECORD (SHEET 3 OF 3) STATE JOB NO. 09032108 SHEET NO. R004	OKLAHOMA COUNTY
DRAWN	-			
CHECKED	-			
APPROVED	-			
SQUAD	POE			

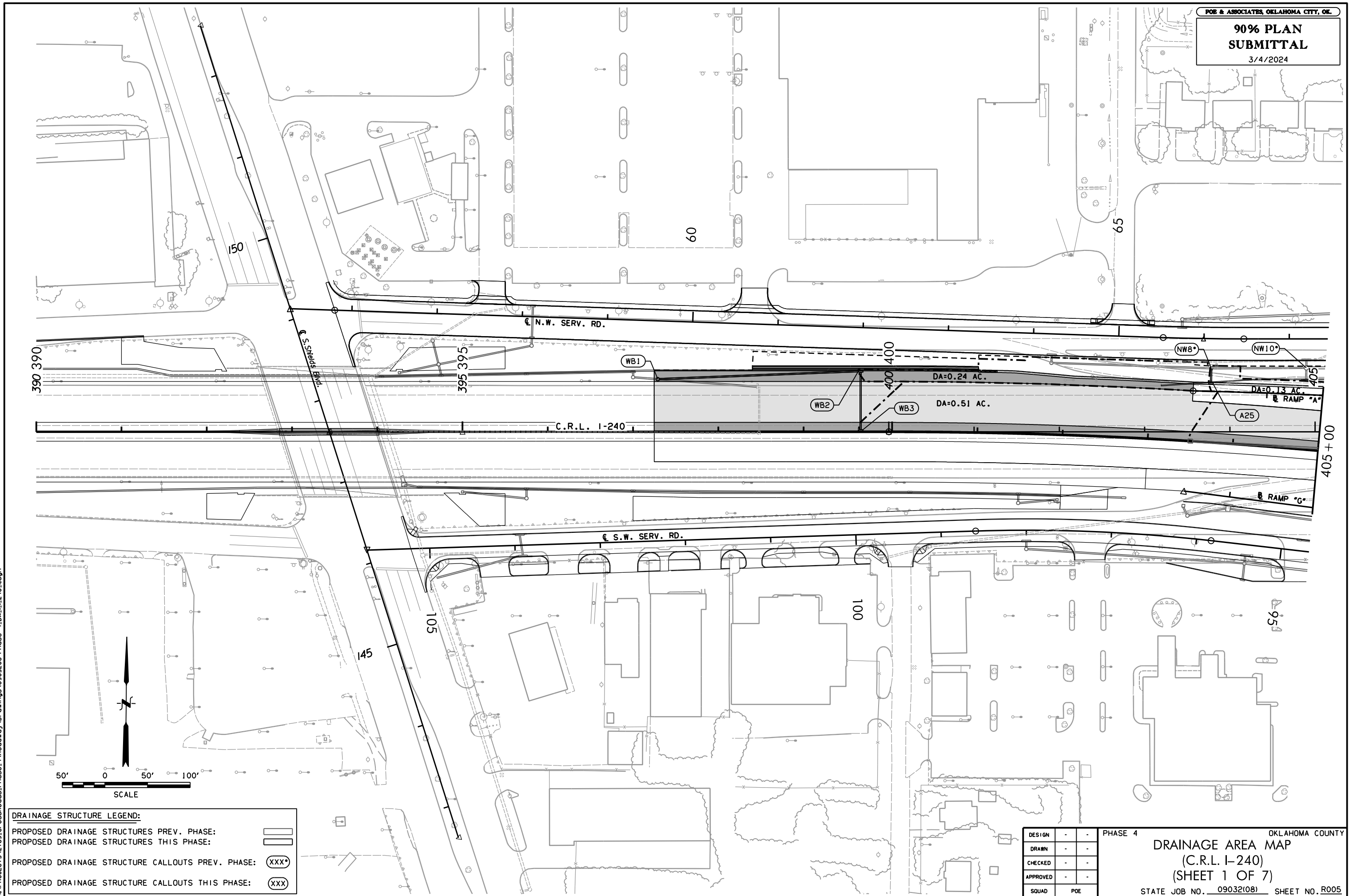

3/4/2024 2:35:18 PM
 H:\PROJECTS\2789_CrossRoads_Phase 4\Roadway\Drawings\0903208-Phase 4_DA_I-240.dgn

DRAINAGE STRUCTURE LEGEND:

PROPOSED DRAINAGE STRUCTURES PREV. PHASE:	
PROPOSED DRAINAGE STRUCTURES THIS PHASE:	
PROPOSED DRAINAGE STRUCTURE CALLOUTS PREV. PHASE:	(XXX)
PROPOSED DRAINAGE STRUCTURE CALLOUTS THIS PHASE:	(XXX)

DESIGN	-	-
DRAWN	-	-
CHECKED	-	-
APPROVED	-	-
SQUAD	POE	

PHASE 4
 OKLAHOMA COUNTY
DRAINAGE AREA MAP
 (C.R.L. I-240)
 (SHEET 1 OF 7)
 STATE JOB NO. 09032108 SHEET NO. R005

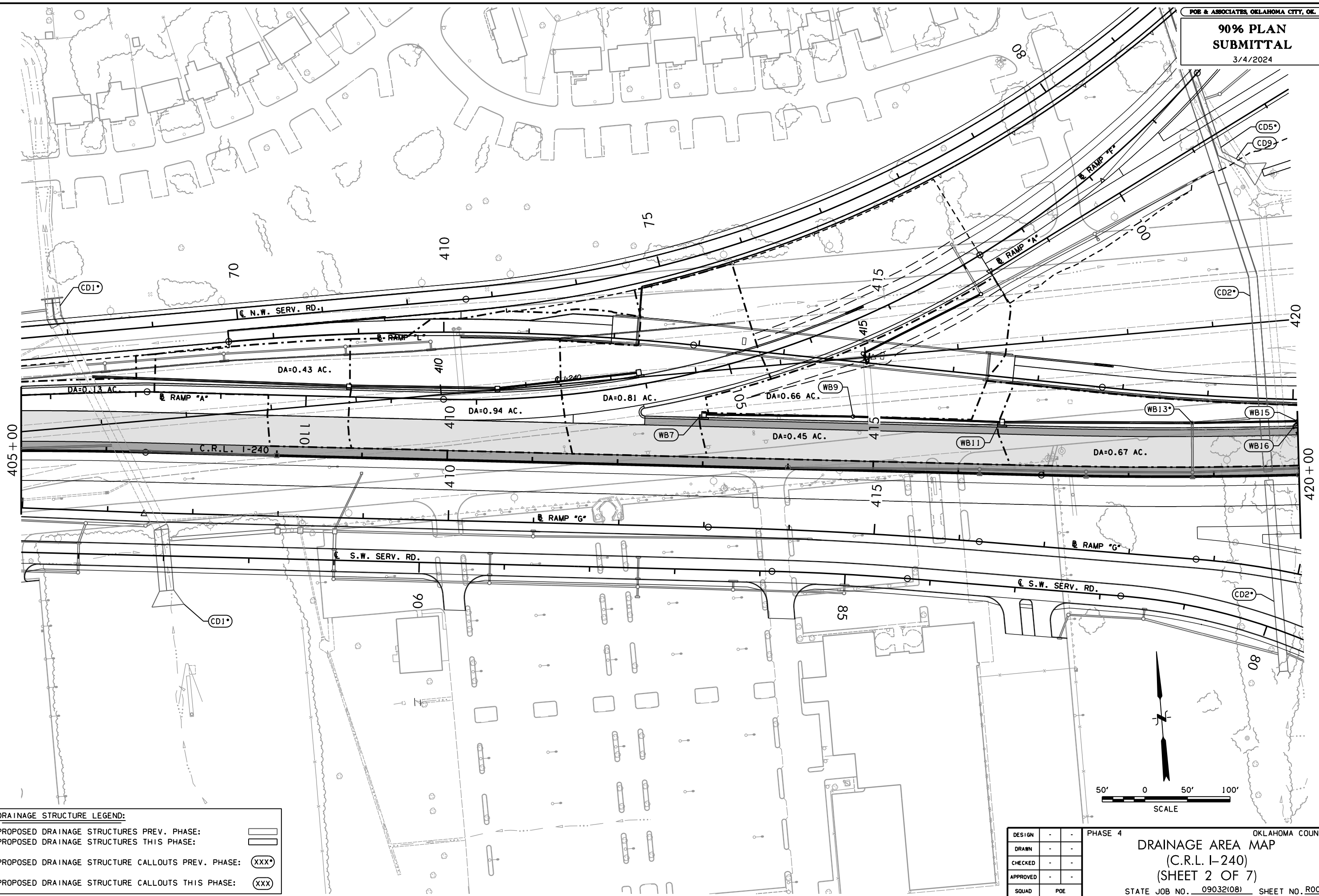

3/4/2024 2:35:22 PM H:\PROJECTS\2789_Crossroads_Phase 4\Roadway\Drawings\0903208-Phase 4.DA.2.1-240.2.dgn

DRAINAGE STRUCTURE LEGEND:

PROPOSED DRAINAGE STRUCTURES PREV. PHASE:	
PROPOSED DRAINAGE STRUCTURES THIS PHASE:	
PROPOSED DRAINAGE STRUCTURE CALLOUTS PREV. PHASE:	(XXX)
PROPOSED DRAINAGE STRUCTURE CALLOUTS THIS PHASE:	(XXX)

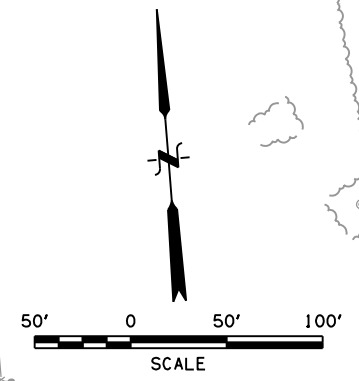

DESIGN	-	-	PHASE 4	OKLAHOMA COUNTY
DRAWN	-	-	DRAINAGE AREA MAP (C.R.L. I-240) (SHEET 2 OF 7) STATE JOB NO. 09032108 SHEET NO. R006	
CHECKED	-	-		
APPROVED	-	-		
SQUAD	POE			

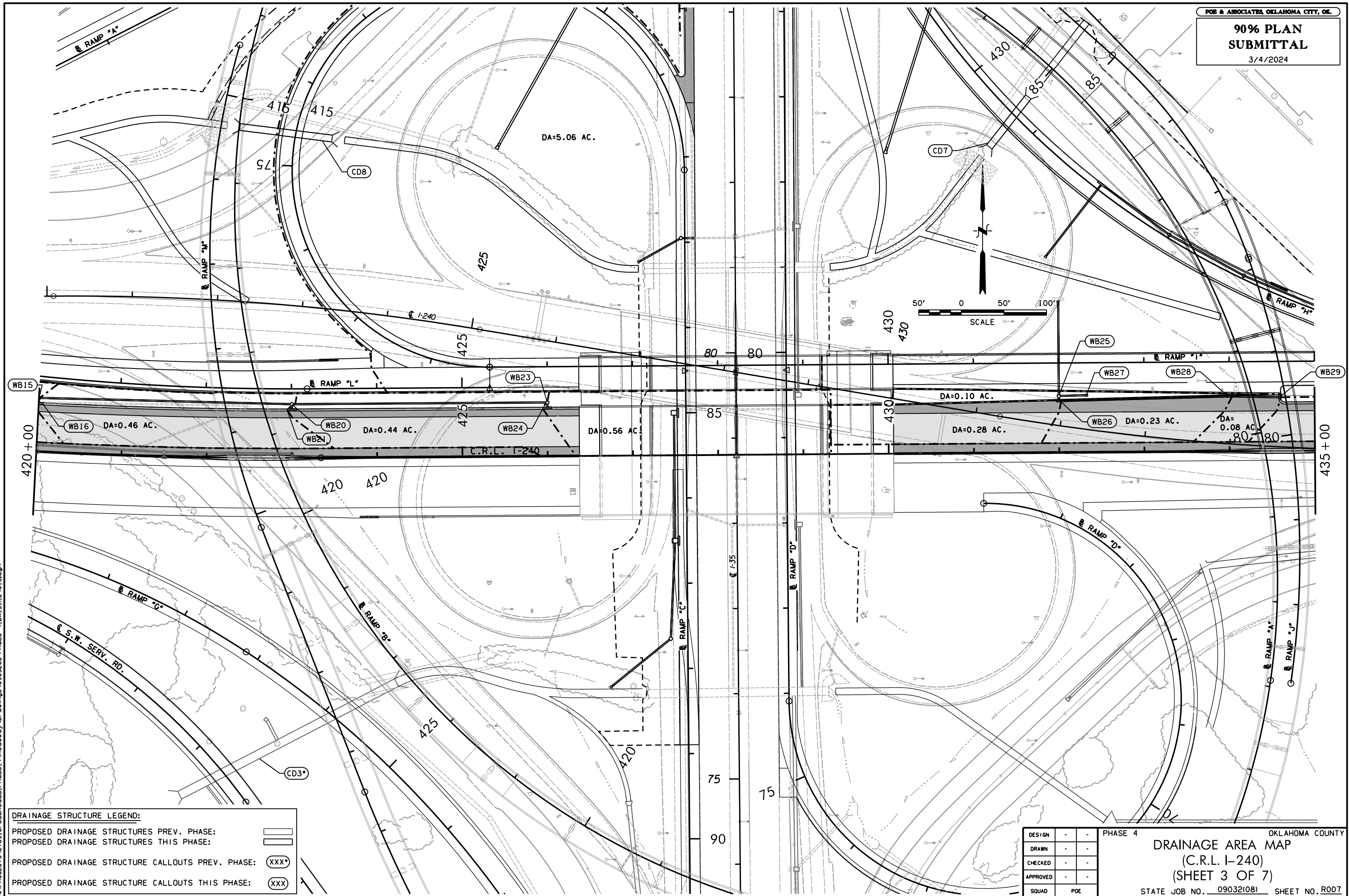

3/4/2024 2:35:24 PM H:\PROJECTS\2789_CrossRoads_Phase 4\Roadway\Drawings\0903208-Phase 4.DA.3.1.1.240.3.dgn

DRAINAGE STRUCTURE LEGEND:

PROPOSED DRAINAGE STRUCTURES PREV. PHASE:	
PROPOSED DRAINAGE STRUCTURES THIS PHASE:	
PROPOSED DRAINAGE STRUCTURE CALLOUTS PREV. PHASE:	(XXX)
PROPOSED DRAINAGE STRUCTURE CALLOUTS THIS PHASE:	(XXX)

DESIGN	-	-	PHASE 4
DRAWN	-	-	
CHECKED	-	-	
APPROVED	-	-	
SQUAD	POE		

OKLAHOMA COUNTY
DRAINAGE AREA MAP
 (C.R.L. I-240)
 (SHEET 3 OF 7)
 STATE JOB NO. 090321081 SHEET NO. R007

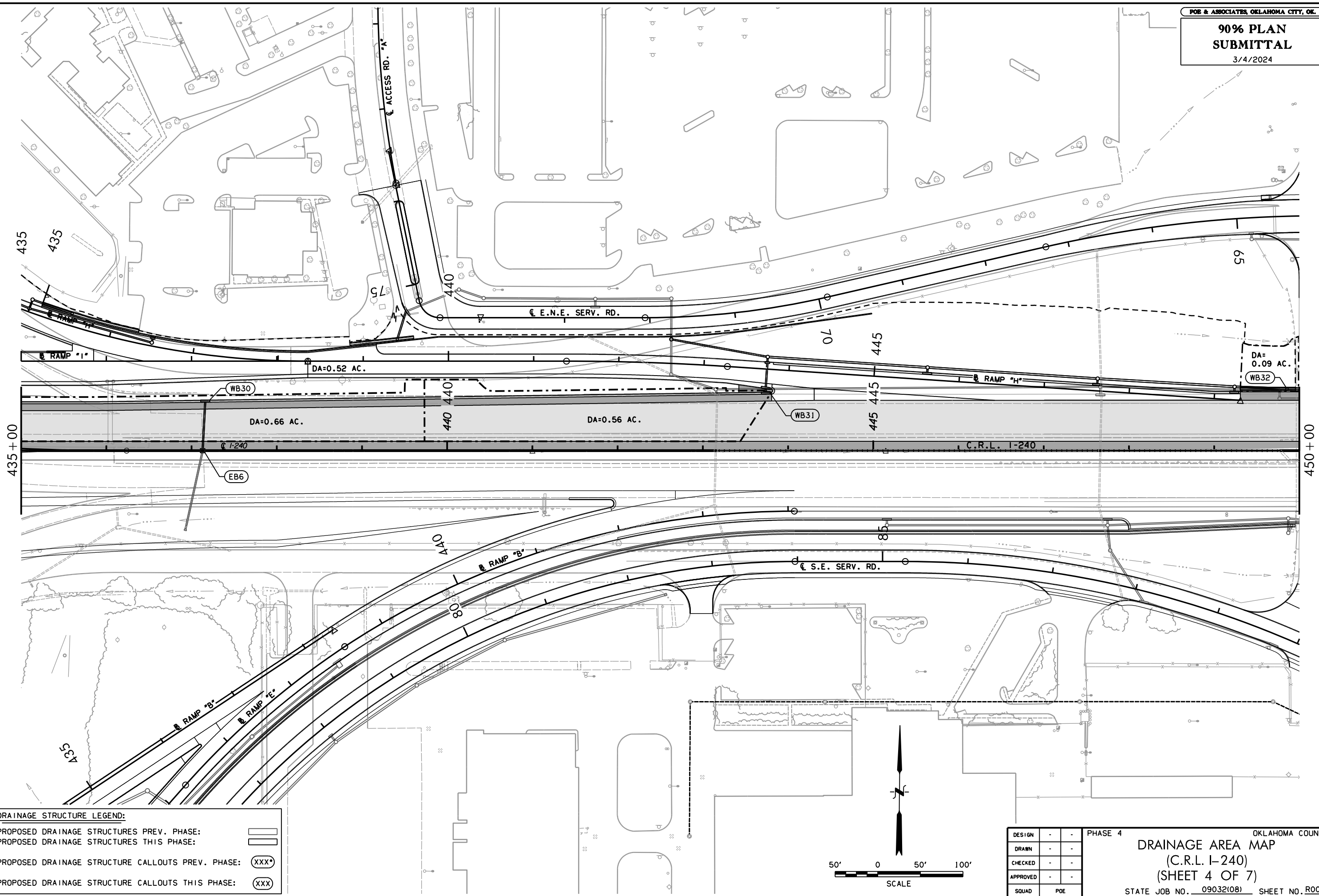

3/4/2024 2:35:27 PM
 H:\PROJECTS\2789_CrossRoads_Phase 4\Roadway\Drawings\0903208-Phase 4_DA_4_1_240_4.dgn

DRAINAGE STRUCTURE LEGEND:

PROPOSED DRAINAGE STRUCTURES PREV. PHASE:	
PROPOSED DRAINAGE STRUCTURES THIS PHASE:	
PROPOSED DRAINAGE STRUCTURE CALLOUTS PREV. PHASE:	(XXX)
PROPOSED DRAINAGE STRUCTURE CALLOUTS THIS PHASE:	(XXX)

DESIGN	-	-
DRAWN	-	-
CHECKED	-	-
APPROVED	-	-
SQUAD	POE	

PHASE 4
 OKLAHOMA COUNTY
DRAINAGE AREA MAP
 (C.R.L. I-240)
 (SHEET 4 OF 7)
 STATE JOB NO. 090321081 SHEET NO. R008

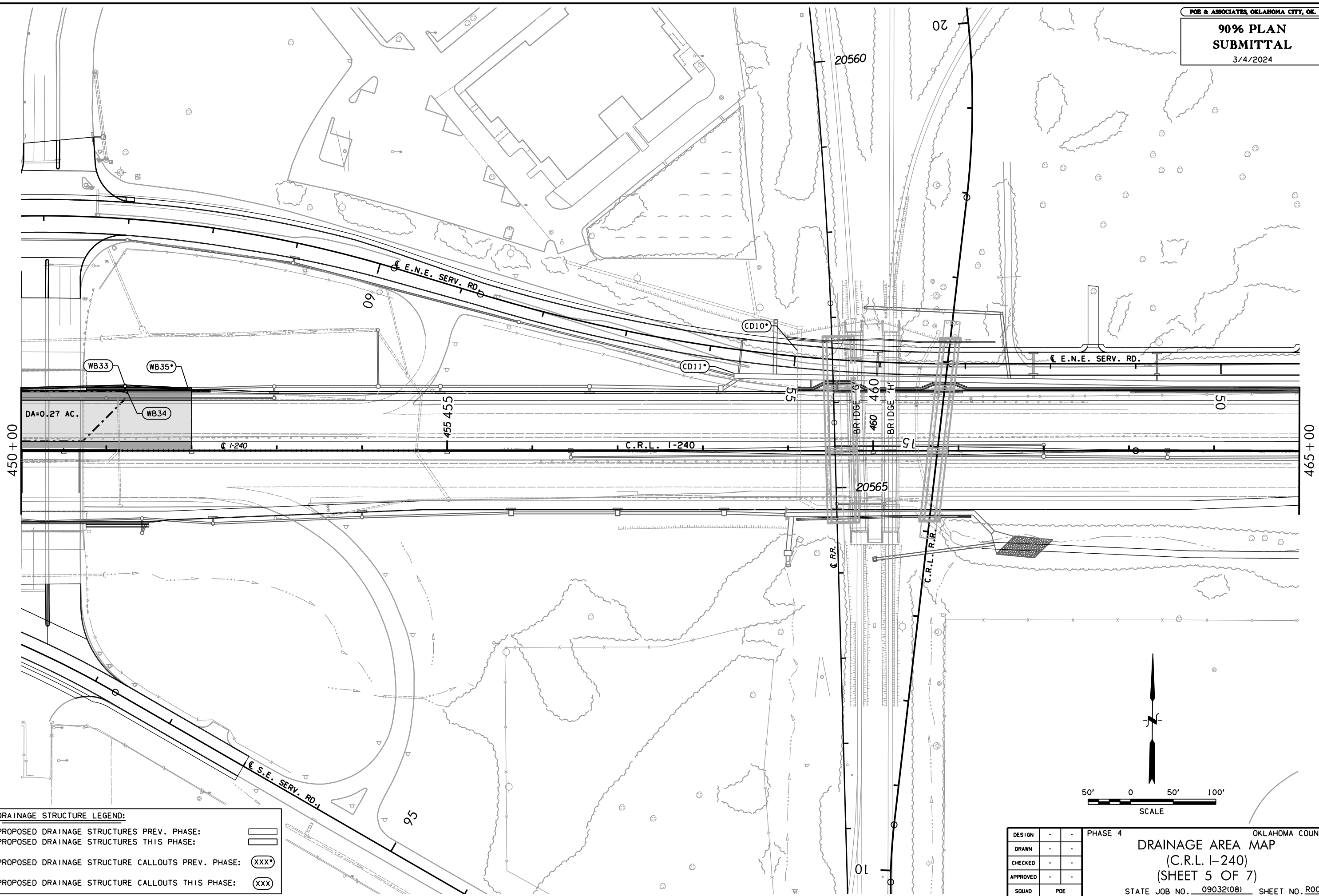

3/4/2024 2:35:30 PM
 H:\PROJECTS\2789_Crossroads_Phase 4\Roadway\Drawings\0903208-Phase 4_DA_5_1_240_5.dgn

DRAINAGE STRUCTURE LEGEND:

PROPOSED DRAINAGE STRUCTURES PREV. PHASE:	
PROPOSED DRAINAGE STRUCTURES THIS PHASE:	
PROPOSED DRAINAGE STRUCTURE CALLOUTS PREV. PHASE:	(XXX*)
PROPOSED DRAINAGE STRUCTURE CALLOUTS THIS PHASE:	(XXX)

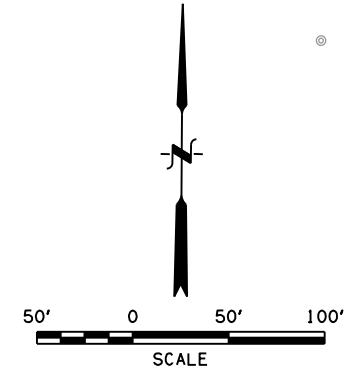

DESIGN	-	-
DRAWN	-	-
CHECKED	-	-
APPROVED	-	-
SQUAD	POE	

PHASE 4
 OKLAHOMA COUNTY
DRAINAGE AREA MAP
 (C.R.L. I-240)
 (SHEET 5 OF 7)
 STATE JOB NO. 090321081 SHEET NO. R009

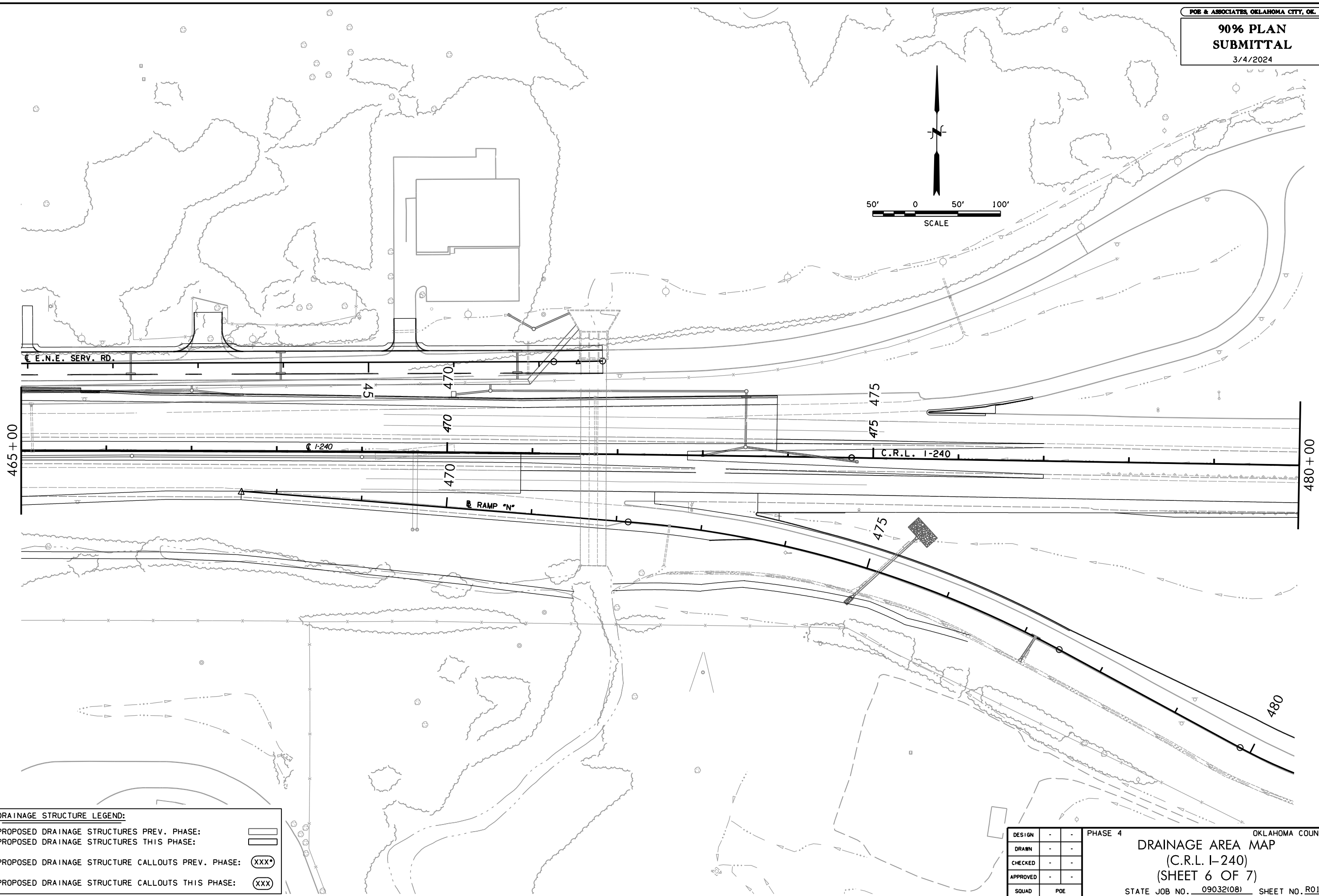
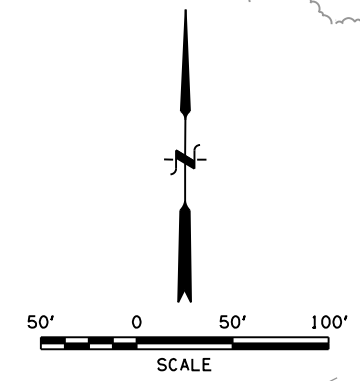

3/4/2024 2:35:33 PM
H:\PROJECTS\2789_CrossRoads_Phase 4\Roadway\Drawings\0903208-Phase 4.DA.6.1.240.6.dgn

DRAINAGE STRUCTURE LEGEND:

PROPOSED DRAINAGE STRUCTURES PREV. PHASE:	
PROPOSED DRAINAGE STRUCTURES THIS PHASE:	
PROPOSED DRAINAGE STRUCTURE CALLOUTS PREV. PHASE:	(XXX)
PROPOSED DRAINAGE STRUCTURE CALLOUTS THIS PHASE:	(XXX)

DESIGN	-	-
DRAWN	-	-
CHECKED	-	-
APPROVED	-	-
SQUAD	POE	

PHASE 4
OKLAHOMA COUNTY

DRAINAGE AREA MAP
(C.R.L. I-240)
(SHEET 6 OF 7)

STATE JOB NO. 09032(08) SHEET NO. R010

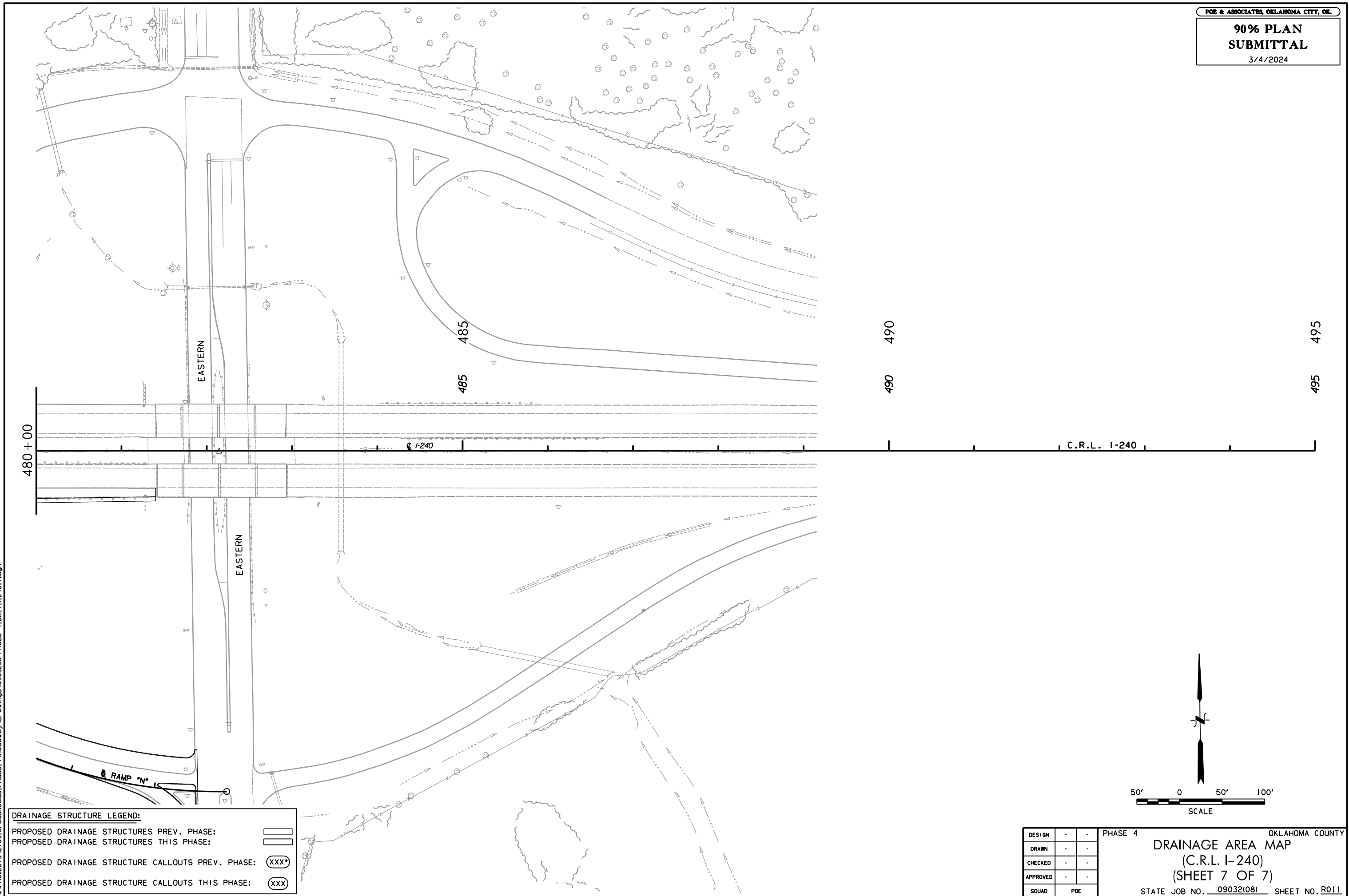

3/4/2024 2:35:34 PM
H:\PROJECTS\2789_CrossRoads_Phase 4\Roadway\Drawings\0903208-Phase 4_DA_T.I.240.7.dgn

DRAINAGE STRUCTURE LEGEND:

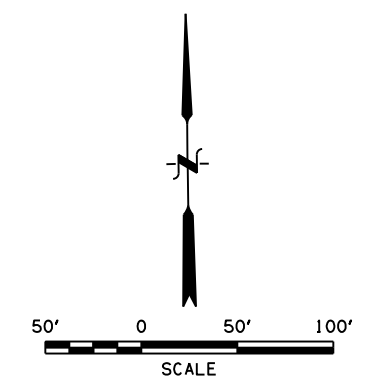

PROPOSED DRAINAGE STRUCTURES PREV. PHASE:	
PROPOSED DRAINAGE STRUCTURES THIS PHASE:	
PROPOSED DRAINAGE STRUCTURE CALLOUTS PREV. PHASE:	(XXX*)
PROPOSED DRAINAGE STRUCTURE CALLOUTS THIS PHASE:	(XXX)



DESIGN	-	-	PHASE 4	OKLAHOMA COUNTY
DRAWN	-	-	DRAINAGE AREA MAP (C.R.L. I-240) (SHEET 7 OF 7) STATE JOB NO. 09032(08) SHEET NO. R011	
CHECKED	-	-		
APPROVED	-	-		
SQUAD	POE			

3/4/2024 2:35:36 PM H:\PROJECTS\2789_CrossRoads_Phase 4\Roadway\Drawings\0903208-Phase 4.DA.L1.35.lidgn

DRAINAGE STRUCTURE LEGEND:

PROPOSED DRAINAGE STRUCTURES PREV. PHASE:	
PROPOSED DRAINAGE STRUCTURES THIS PHASE:	
PROPOSED DRAINAGE STRUCTURE CALLOUTS PREV. PHASE:	(XXX)
PROPOSED DRAINAGE STRUCTURE CALLOUTS THIS PHASE:	(XXX)

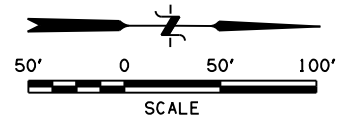
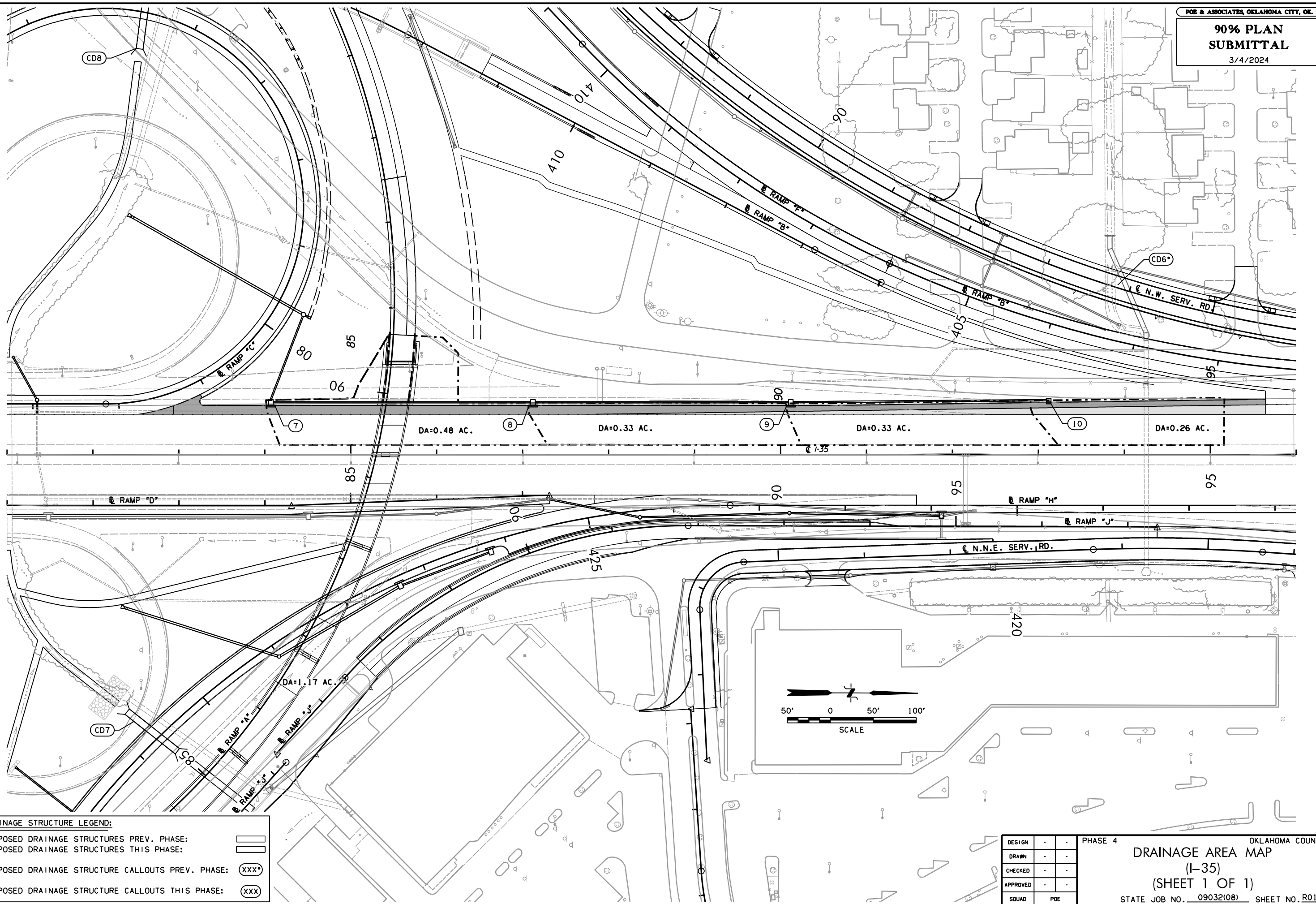

DESIGN	-	-	PHASE 4
DRAWN	-	-	
CHECKED	-	-	
APPROVED	-	-	
SQUAD	POE		

OKLAHOMA COUNTY
DRAINAGE AREA MAP
 (I-35)
 (SHEET 1 OF 1)
 STATE JOB NO. 09032108) SHEET NO. R012

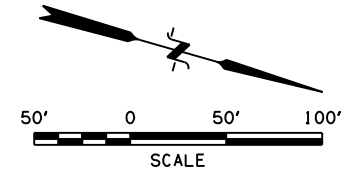

3/4/2024 2:35:40 PM H:\PROJECTS\2789_Crossroads_Phase 4\Roadway\Drawings\0903208-Phase 4_DA_9_Ramp_A_1.dgn

DRAINAGE STRUCTURE LEGEND:

PROPOSED DRAINAGE STRUCTURES PREV. PHASE:	
PROPOSED DRAINAGE STRUCTURES THIS PHASE:	
PROPOSED DRAINAGE STRUCTURE CALLOUTS PREV. PHASE:	(XXX)
PROPOSED DRAINAGE STRUCTURE CALLOUTS THIS PHASE:	(XXX)



DESIGN	-	-
DRAWN	-	-
CHECKED	-	-
APPROVED	-	-
SQUAD	POE	

PHASE 4
 DRAINAGE AREA MAP
 (RAMP "A")
 (SHEET 1 OF 2)
 STATE JOB NO. 090321081 SHEET NO. R013
 OKLAHOMA COUNTY

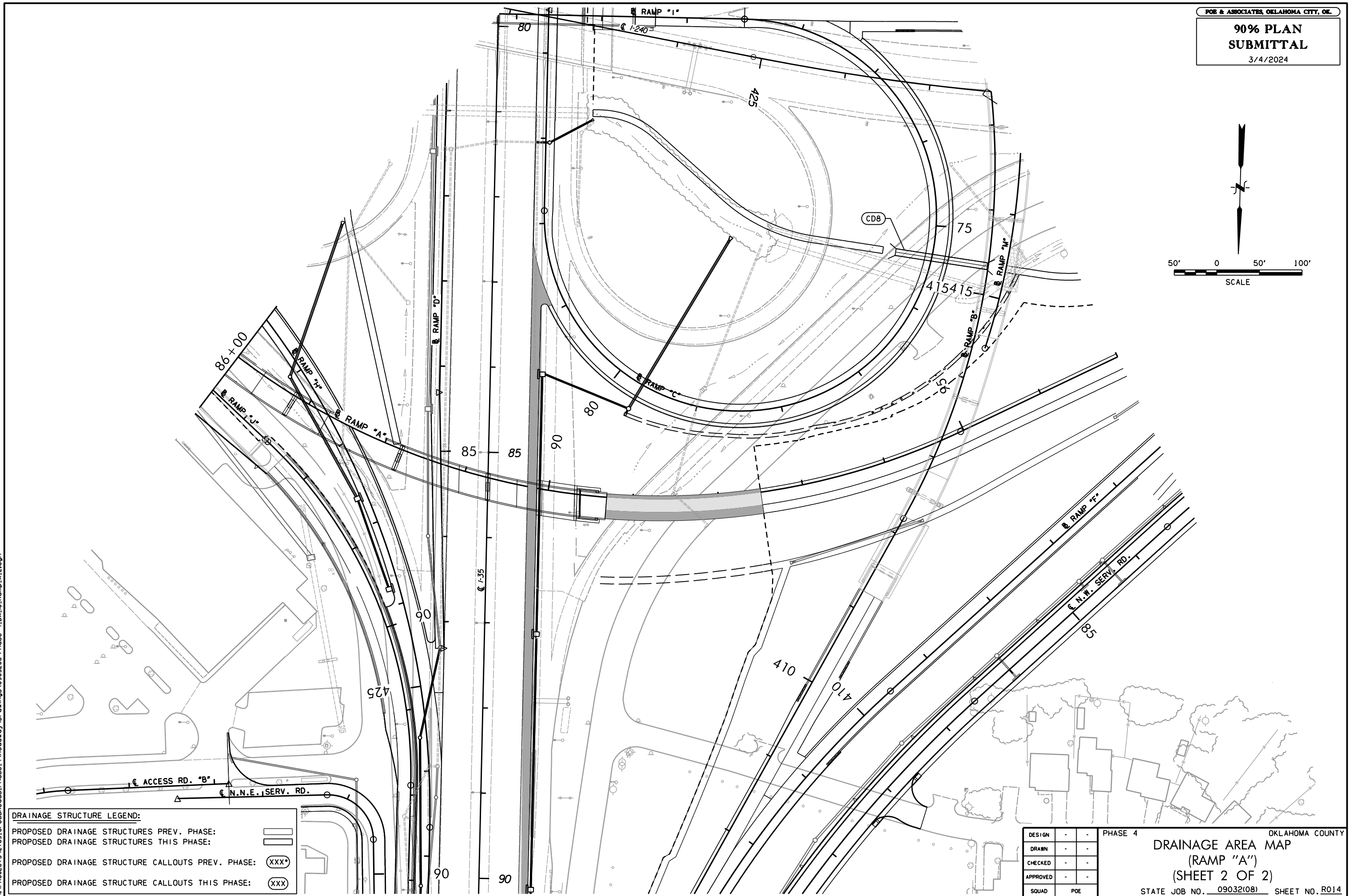
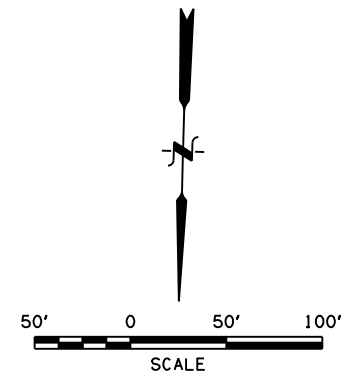

3/4/2024 2:35:44 PM
H:\PROJECTS\2789_CrossRoads_Phase 4\Roadway\Drawings\0903208-Phase 4_DA_10_Ramp_A.2.dgn

DRAINAGE STRUCTURE LEGEND:

PROPOSED DRAINAGE STRUCTURES PREV. PHASE:	
PROPOSED DRAINAGE STRUCTURES THIS PHASE:	
PROPOSED DRAINAGE STRUCTURE CALLOUTS PREV. PHASE:	(XXX)
PROPOSED DRAINAGE STRUCTURE CALLOUTS THIS PHASE:	(XXX)

DESIGN	-	-	PHASE 4
DRAWN	-	-	
CHECKED	-	-	
APPROVED	-	-	
SQUAD	POE		

OKLAHOMA COUNTY
DRAINAGE AREA MAP
 (RAMP "A")
 (SHEET 2 OF 2)
 STATE JOB NO. 09032(08) SHEET NO. R014

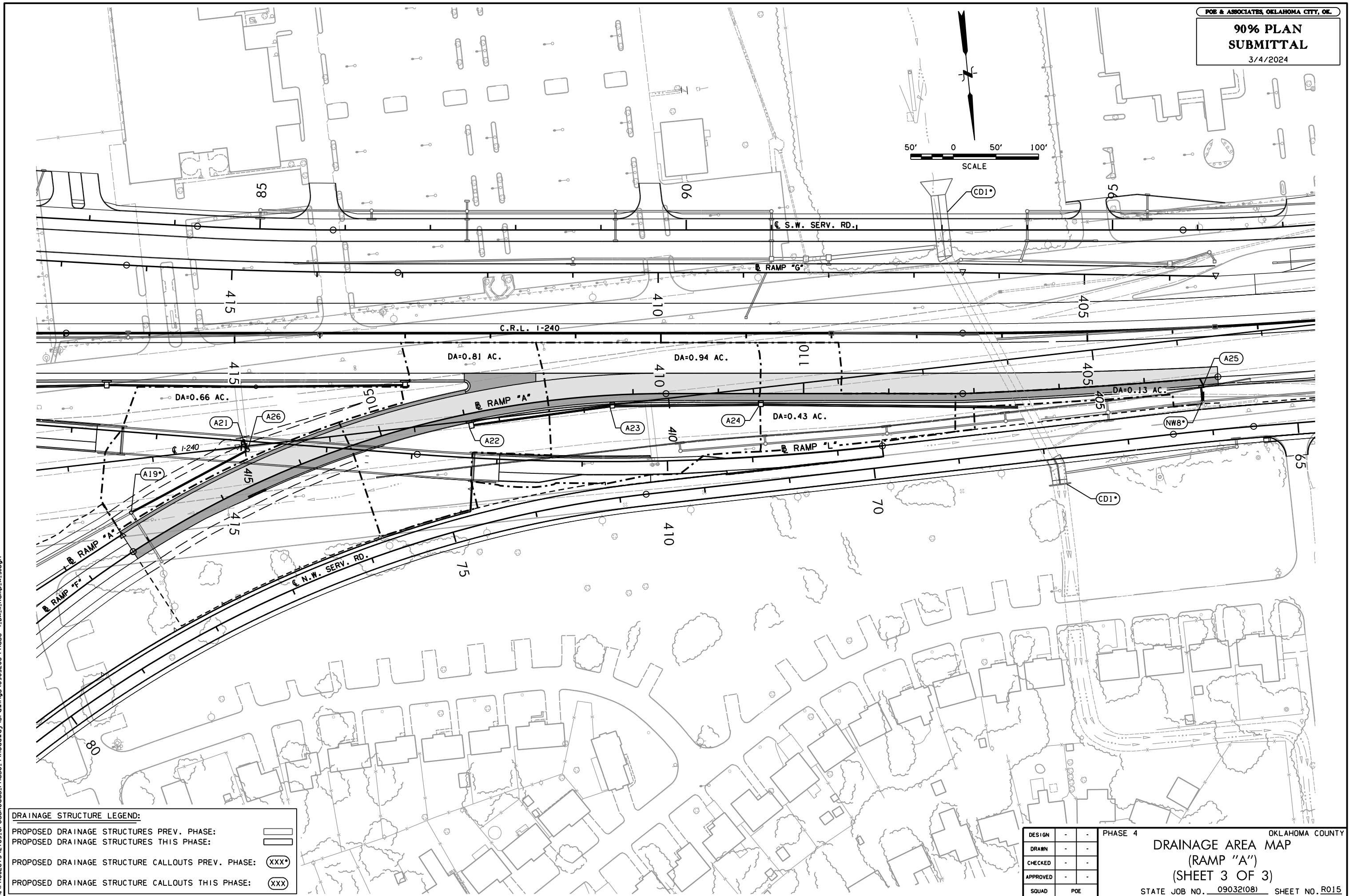
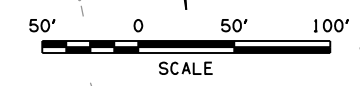

3/4/2024 2:35:48 PM
 H:\PROJECTS\2789_Crossroads_Phase 4\Roadway\Drawings\0903208-Phase 4_DA_IL_Ramp_A_3.dgn

DRAINAGE STRUCTURE LEGEND:

PROPOSED DRAINAGE STRUCTURES PREV. PHASE:	
PROPOSED DRAINAGE STRUCTURES THIS PHASE:	
PROPOSED DRAINAGE STRUCTURE CALLOUTS PREV. PHASE:	(XXX)
PROPOSED DRAINAGE STRUCTURE CALLOUTS THIS PHASE:	(XXX)

DESIGN	-	-	PHASE 4	OKLAHOMA COUNTY
DRAWN	-	-	DRAINAGE AREA MAP (RAMP "A") (SHEET 3 OF 3)	
CHECKED	-	-		
APPROVED	-	-		
SQUAD	POE		STATE JOB NO. 090321081	SHEET NO. R015

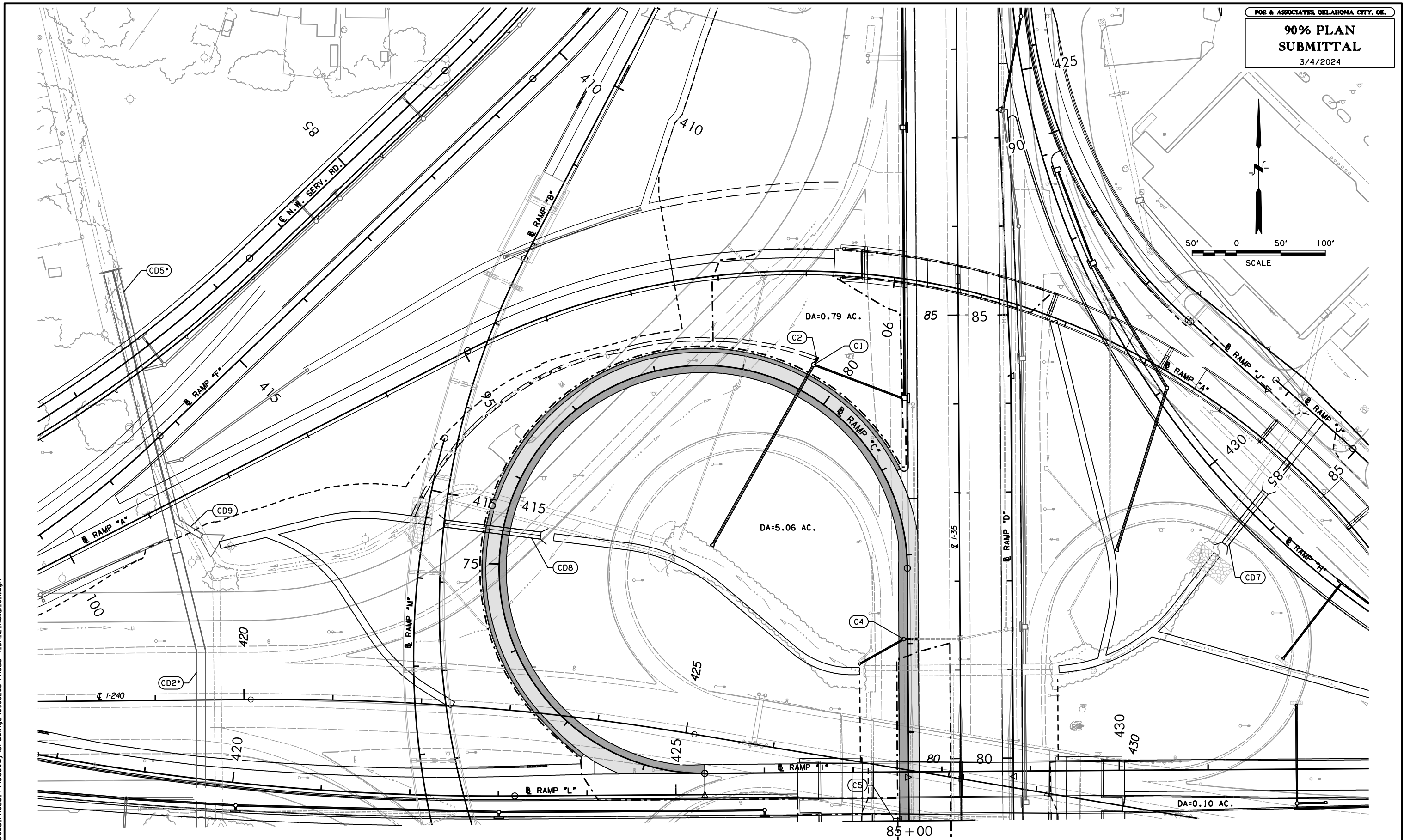
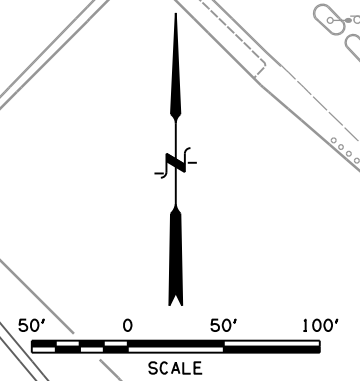

3/4/2024 2:35:51 PM H:\PROJECTS\2789_CrossRoads_Phase 4\Roadway\Drawings\0903208-Phase 4_DA12_Ramp_C.lidgn

DRAINAGE STRUCTURE LEGEND:

PROPOSED DRAINAGE STRUCTURES PREV. PHASE:	
PROPOSED DRAINAGE STRUCTURES THIS PHASE:	
PROPOSED DRAINAGE STRUCTURE CALLOUTS PREV. PHASE:	(XXX)
PROPOSED DRAINAGE STRUCTURE CALLOUTS THIS PHASE:	(XXX)

DESIGN	-	-	PHASE 4	OKLAHOMA COUNTY
DRAWN	-	-	DRAINAGE AREA MAP (RAMP "C") (SHEET 1 OF 2)	
CHECKED	-	-		
APPROVED	-	-		
SQUAD	POE		STATE JOB NO. 090321081	SHEET NO. R016

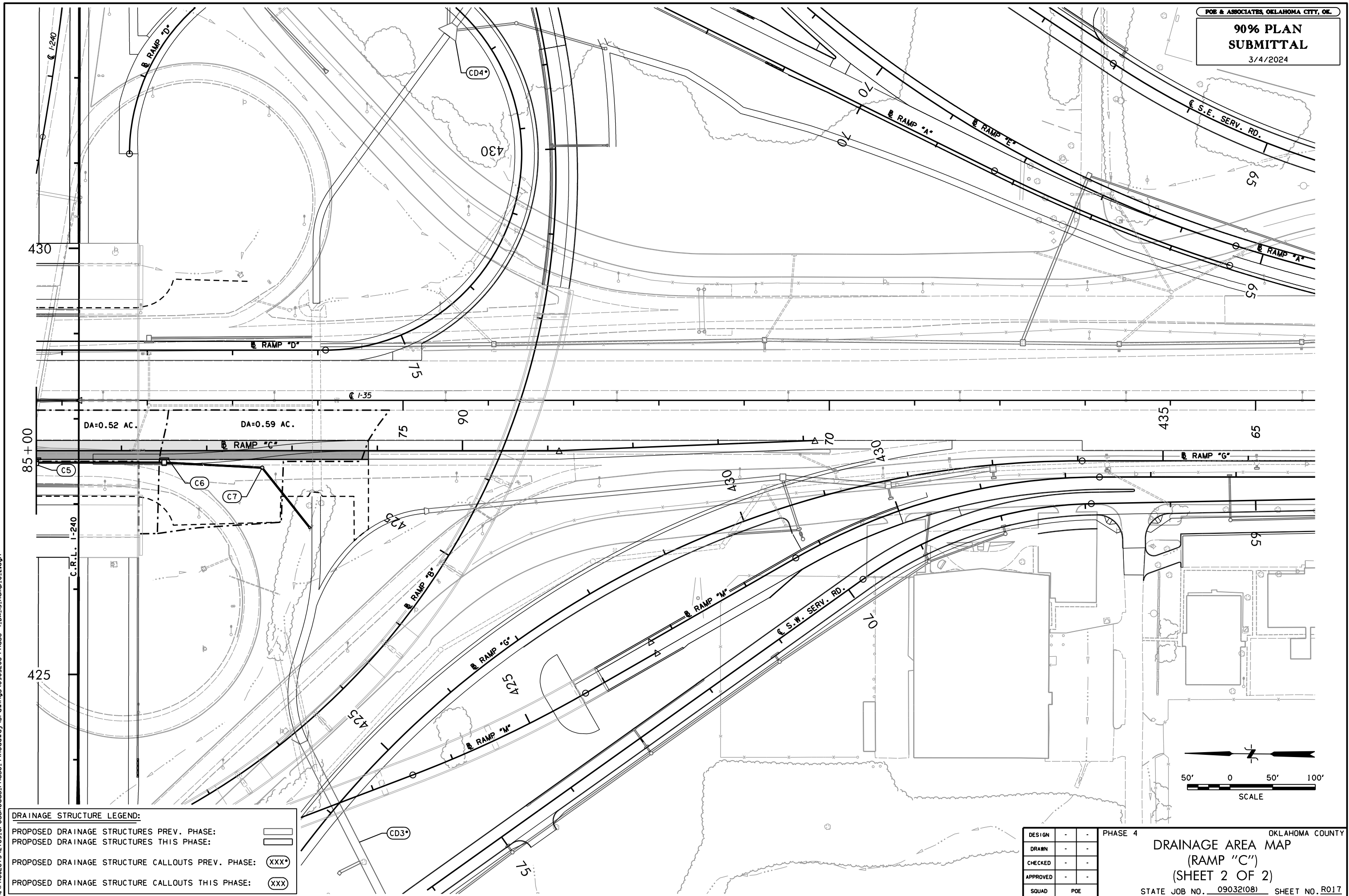

3/4/2024 2:35:54 PM
H:\PROJECTS\2789_CrossRoads_Phase 4\Roadway\Drawings\0903208-Phase 4_DA_13_Ramp_C.2.dgn

DRAINAGE STRUCTURE LEGEND:

PROPOSED DRAINAGE STRUCTURES PREV. PHASE:	
PROPOSED DRAINAGE STRUCTURES THIS PHASE:	
PROPOSED DRAINAGE STRUCTURE CALLOUTS PREV. PHASE:	(XXX)
PROPOSED DRAINAGE STRUCTURE CALLOUTS THIS PHASE:	(XXX)

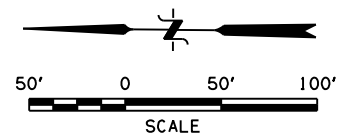

DESIGN	-	-
DRAWN	-	-
CHECKED	-	-
APPROVED	-	-
SQUAD	POE	

PHASE 4
OKLAHOMA COUNTY
**DRAINAGE AREA MAP
(RAMP "C")
(SHEET 2 OF 2)**
STATE JOB NO. 090321081 SHEET NO. R017

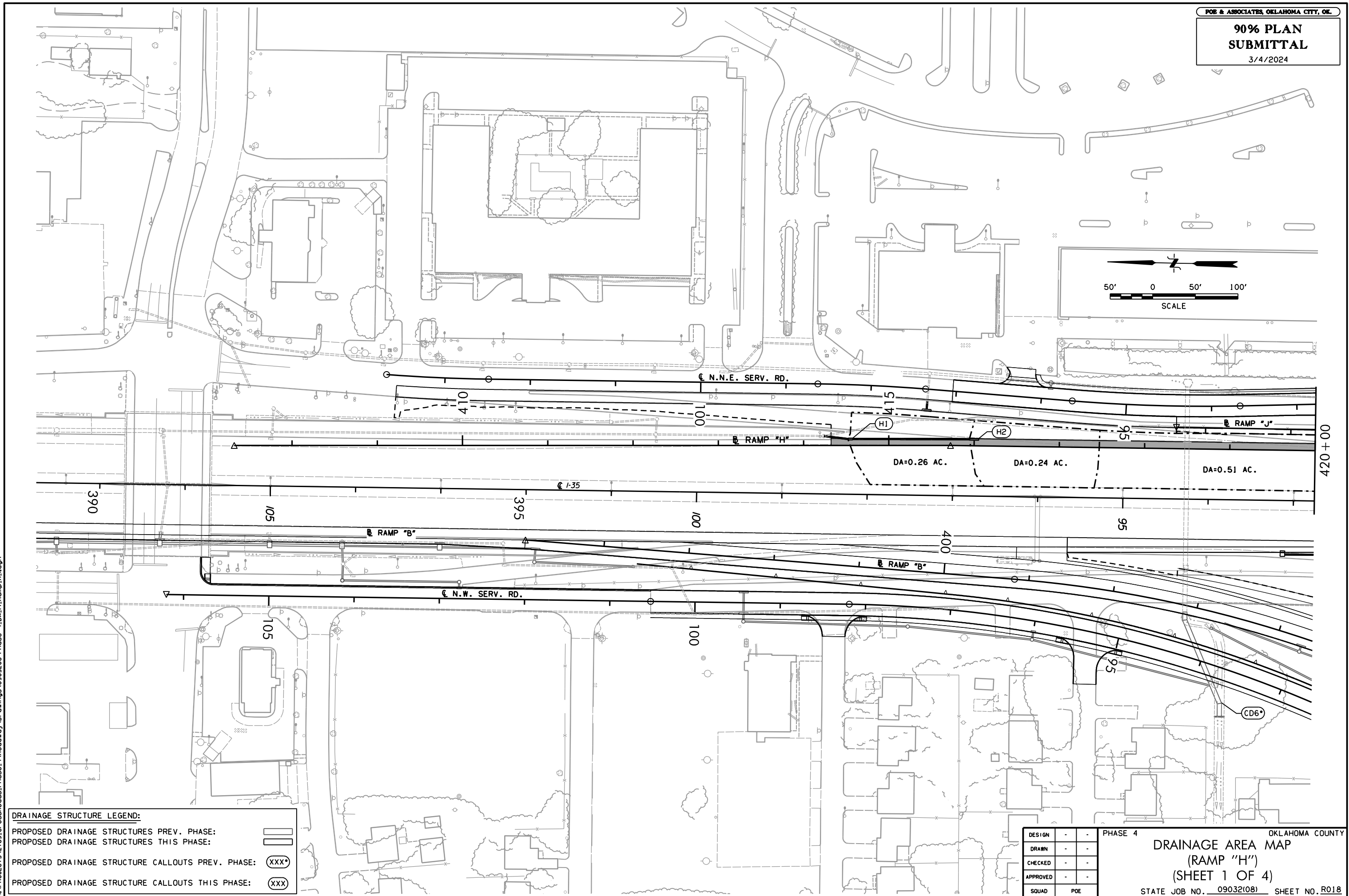
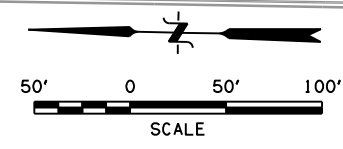

3/4/2024 2:35:56 PM H:\PROJECTS\2789_CrossRoads_Phase 4\Roadway\Drawings\0903208-Phase 4_DA_H_Ramp_H.I.dgn

DRAINAGE STRUCTURE LEGEND:

PROPOSED DRAINAGE STRUCTURES PREV. PHASE:	
PROPOSED DRAINAGE STRUCTURES THIS PHASE:	
PROPOSED DRAINAGE STRUCTURE CALLOUTS PREV. PHASE:	(XXX)
PROPOSED DRAINAGE STRUCTURE CALLOUTS THIS PHASE:	(XXX)

DESIGN	-	-
DRAWN	-	-
CHECKED	-	-
APPROVED	-	-
SQUAD	POE	

PHASE 4
OKLAHOMA COUNTY

**DRAINAGE AREA MAP
(RAMP "H")
(SHEET 1 OF 4)**

STATE JOB NO. 09032108 SHEET NO. R018

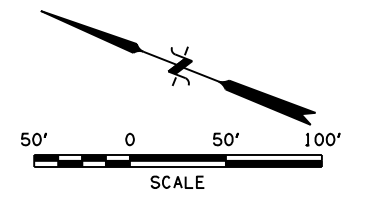

3/4/2024 2:35:59 PM H:\PROJECTS\2789_CrossRoads_Phase 4\Roadway\Drawings\0903208-Phase 4_DA_15_Ramp_H.2.dgn

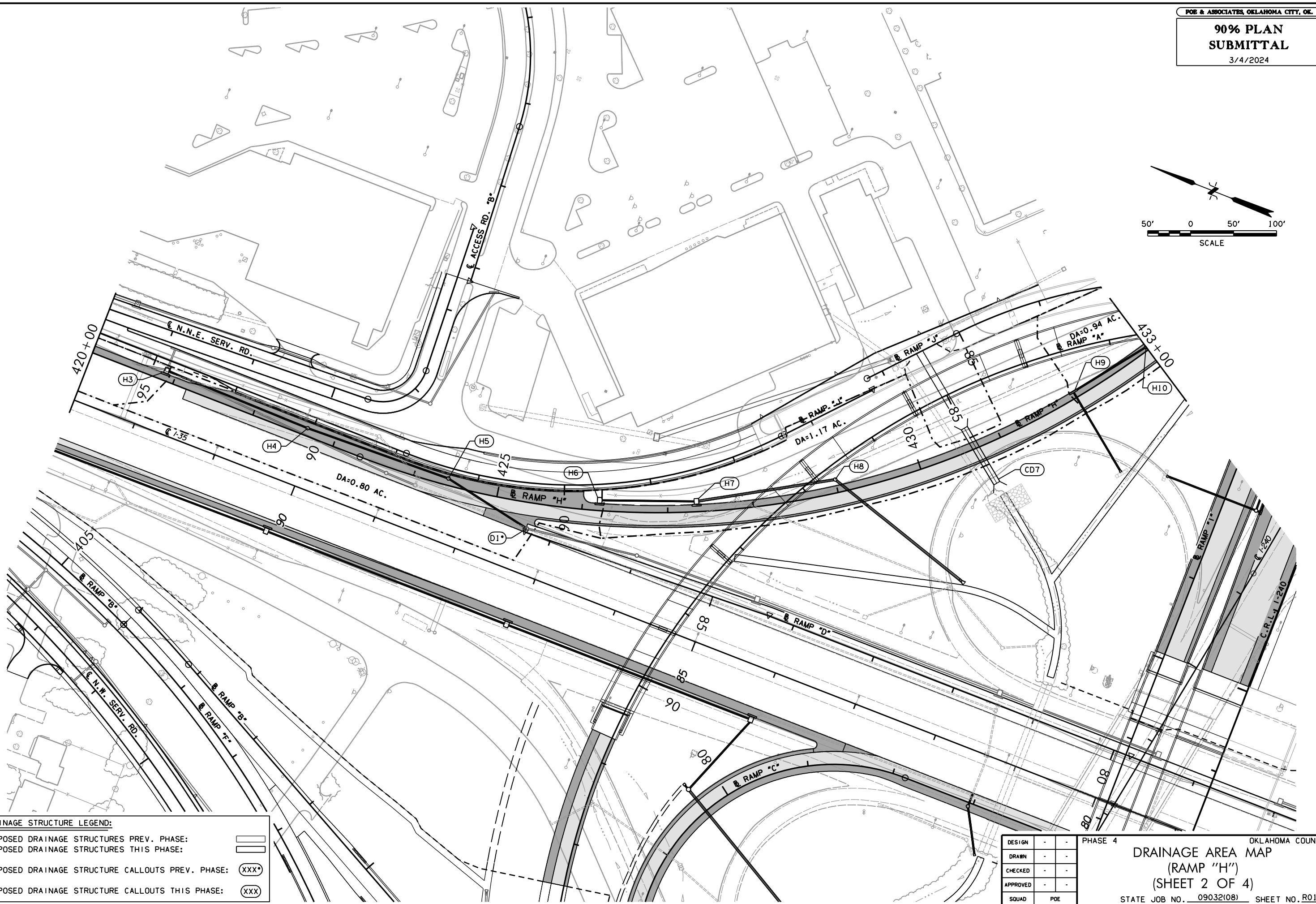

DRAINAGE STRUCTURE LEGEND:

PROPOSED DRAINAGE STRUCTURES PREV. PHASE:	
PROPOSED DRAINAGE STRUCTURES THIS PHASE:	
PROPOSED DRAINAGE STRUCTURE CALLOUTS PREV. PHASE:	(XXX)
PROPOSED DRAINAGE STRUCTURE CALLOUTS THIS PHASE:	(XXX)

DESIGN	-	-	PHASE 4
DRAWN	-	-	
CHECKED	-	-	
APPROVED	-	-	
SQUAD	POE		

OKLAHOMA COUNTY
DRAINAGE AREA MAP
 (RAMP "H")
 (SHEET 2 OF 4)
 STATE JOB NO. 090321081 SHEET NO. R019

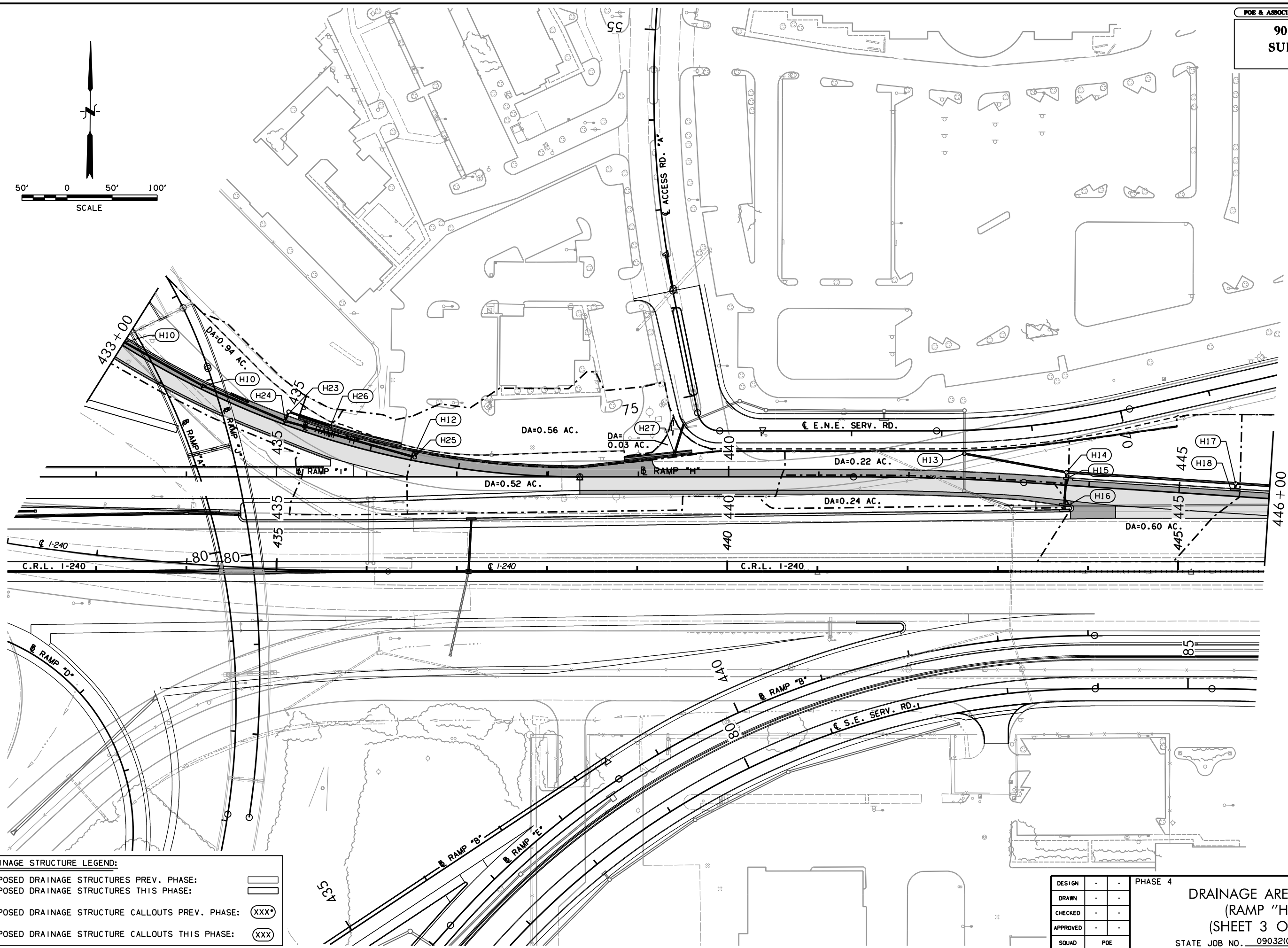
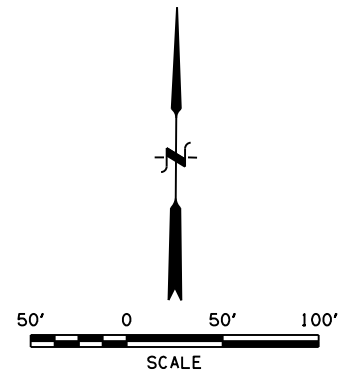

3/4/2024 2:36:02 PM
H:\PROJECTS\2789_CrossRoads_Phase 4\Roadway\Drawings\0903208-Phase 4_DA_16_Ramp_H_3.dgn

DRAINAGE STRUCTURE LEGEND:

PROPOSED DRAINAGE STRUCTURES PREV. PHASE:	
PROPOSED DRAINAGE STRUCTURES THIS PHASE:	
PROPOSED DRAINAGE STRUCTURE CALLOUTS PREV. PHASE:	(XXX)
PROPOSED DRAINAGE STRUCTURE CALLOUTS THIS PHASE:	(XXX)

DESIGN	-	-	PHASE 4
DRAWN	-	-	
CHECKED	-	-	
APPROVED	-	-	
SQUAD	POE		

OKLAHOMA COUNTY
DRAINAGE AREA MAP
 (RAMP "H")
 (SHEET 3 OF 4)
 STATE JOB NO. 090321081 SHEET NO. R020

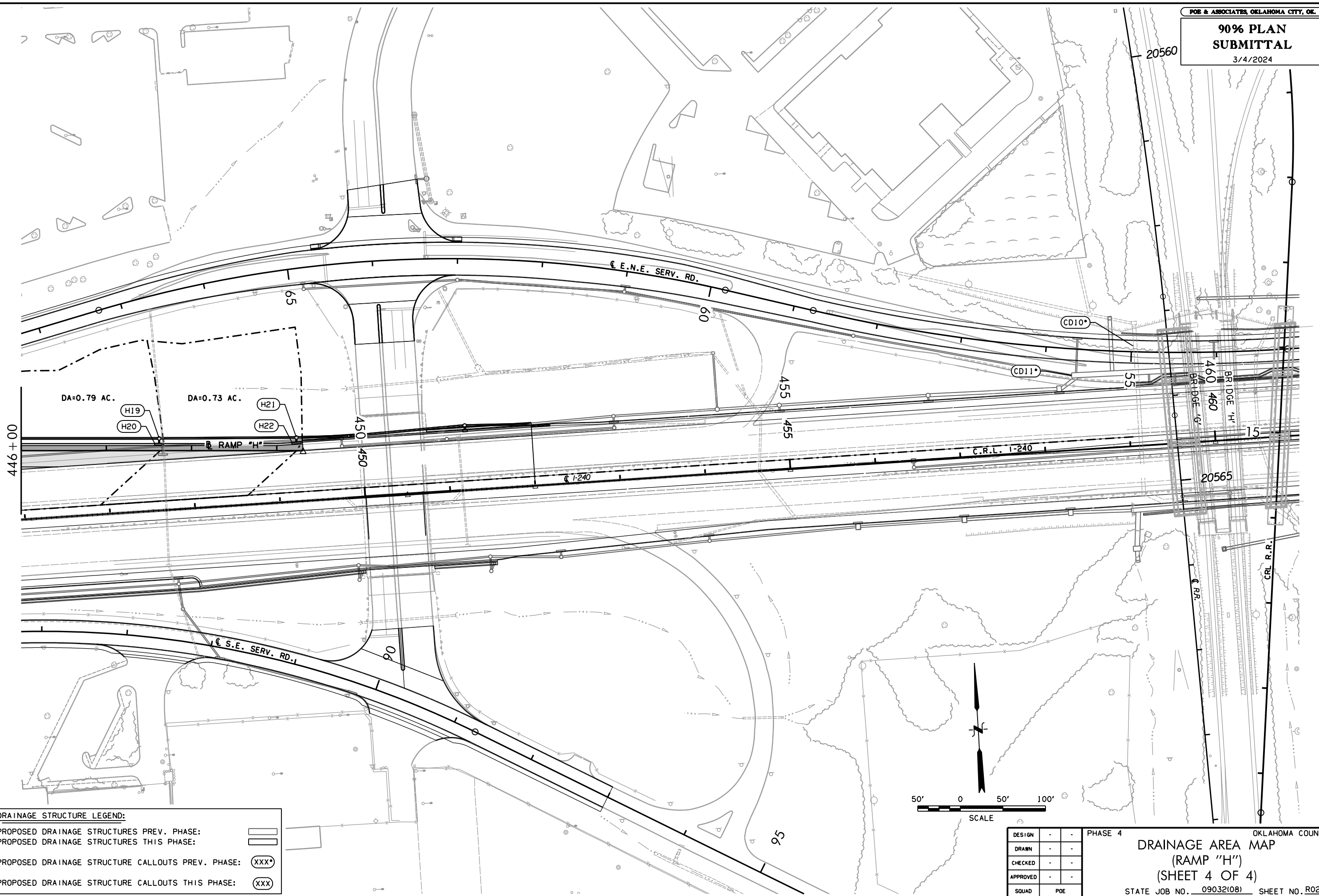

3/4/2024 2:36:06 PM
 H:\PROJECTS\2789_Crossroads_Phase 4\Roadway\Drawings\0903208-Phase 4_DA.IT_Ramp_H_4.dgn

DRAINAGE STRUCTURE LEGEND:

PROPOSED DRAINAGE STRUCTURES PREV. PHASE:	
PROPOSED DRAINAGE STRUCTURES THIS PHASE:	
PROPOSED DRAINAGE STRUCTURE CALLOUTS PREV. PHASE:	(XXX)
PROPOSED DRAINAGE STRUCTURE CALLOUTS THIS PHASE:	(XXX)

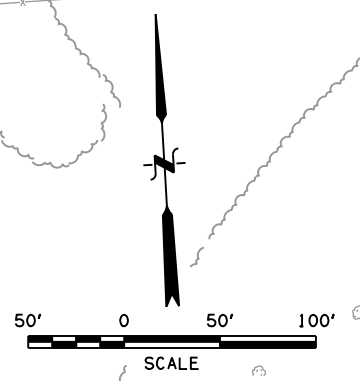

DESIGN	-	-	PHASE 4
DRAWN	-	-	
CHECKED	-	-	
APPROVED	-	-	
SQUAD		POE	

OKLAHOMA COUNTY
DRAINAGE AREA MAP
 (RAMP "H")
 (SHEET 4 OF 4)
 STATE JOB NO. 090321081 SHEET NO. R021

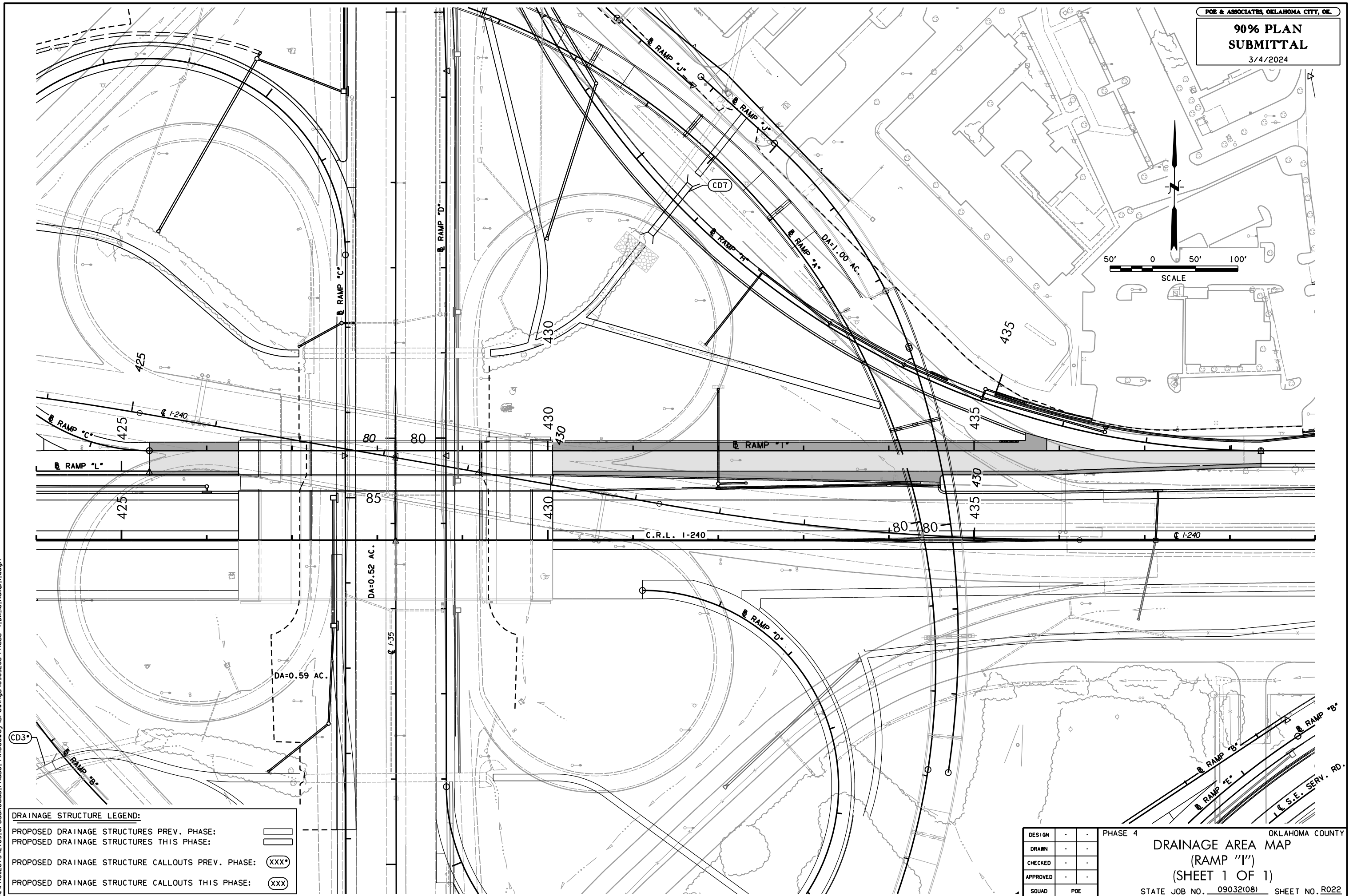
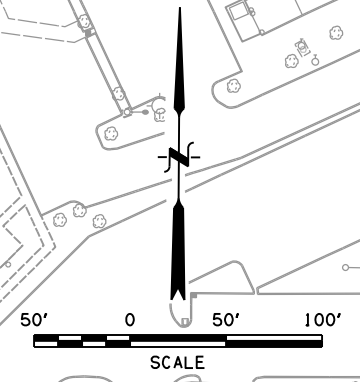

3/4/2024 2:36:14 PM H:\PROJECTS\2789_CrossRoads_Phase 4\Roadway\Drawings\0903208-Phase 4_DA_IB_Ramp_I.dgn

DRAINAGE STRUCTURE LEGEND:

PROPOSED DRAINAGE STRUCTURES PREV. PHASE:	
PROPOSED DRAINAGE STRUCTURES THIS PHASE:	
PROPOSED DRAINAGE STRUCTURE CALLOUTS PREV. PHASE:	(XXX)
PROPOSED DRAINAGE STRUCTURE CALLOUTS THIS PHASE:	(XXX)

DESIGN	-	-
DRAWN	-	-
CHECKED	-	-
APPROVED	-	-
SQUAD	POE	

PHASE 4
OKLAHOMA COUNTY

**DRAINAGE AREA MAP
(RAMP "I")
(SHEET 1 OF 1)**

STATE JOB NO. 090321081 SHEET NO. R022

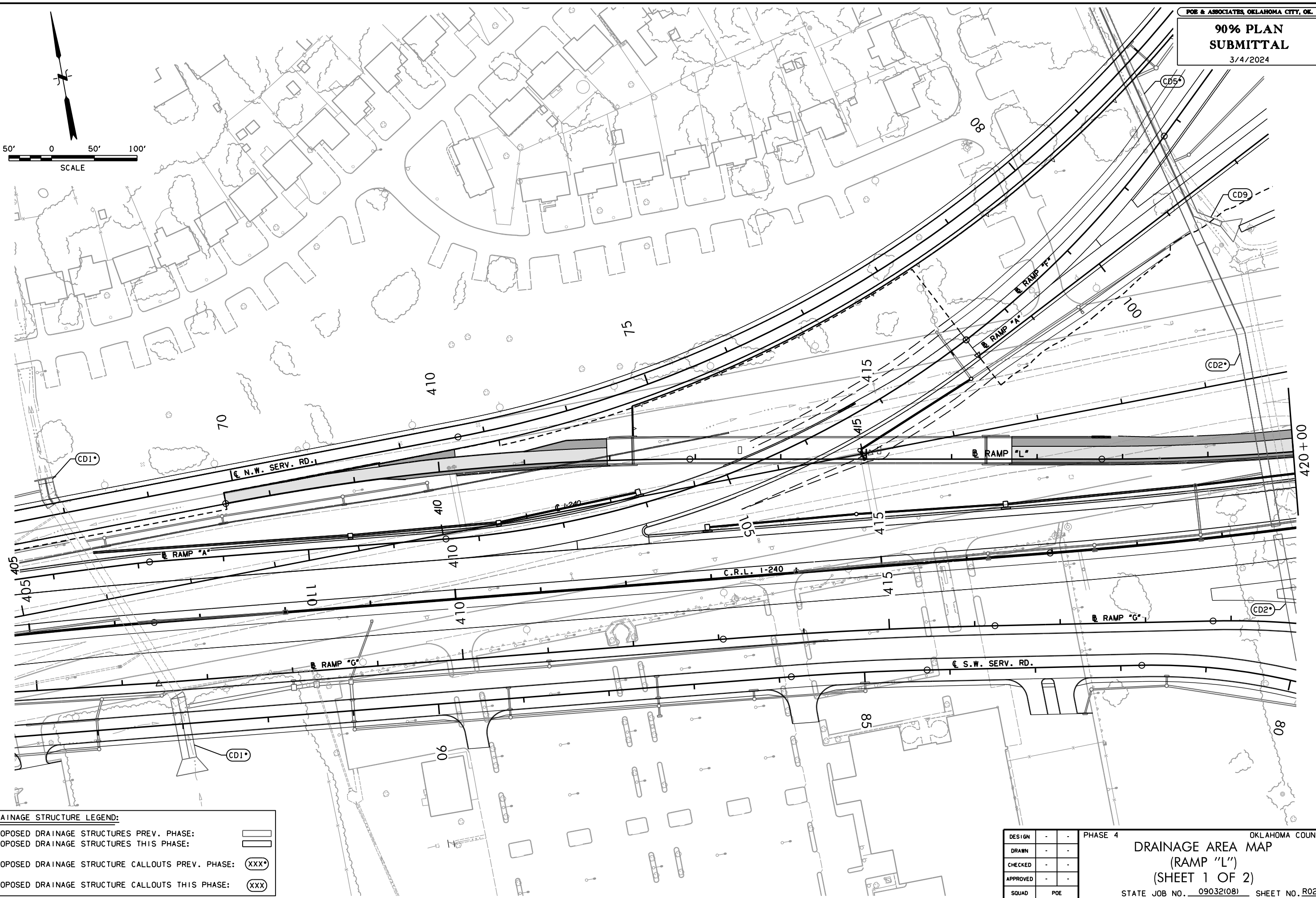
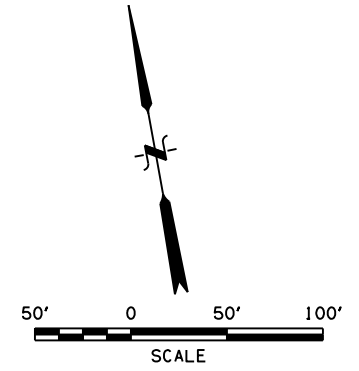

3/4/2024 2:36:17 PM
 H:\PROJECTS\2789_CrossRoads_Phase 4\Roadway\Drawings\0903208-Phase 4_DA_I9_Ramp_L.dgn

DRAINAGE STRUCTURE LEGEND:

PROPOSED DRAINAGE STRUCTURES PREV. PHASE:	
PROPOSED DRAINAGE STRUCTURES THIS PHASE:	
PROPOSED DRAINAGE STRUCTURE CALLOUTS PREV. PHASE:	(XXX)
PROPOSED DRAINAGE STRUCTURE CALLOUTS THIS PHASE:	(XXX)

DESIGN	-	-
DRAWN	-	-
CHECKED	-	-
APPROVED	-	-
SQUAD	POE	

PHASE 4
 OKLAHOMA COUNTY
DRAINAGE AREA MAP
(RAMP "L")
(SHEET 1 OF 2)
 STATE JOB NO. 090321081 SHEET NO. R023

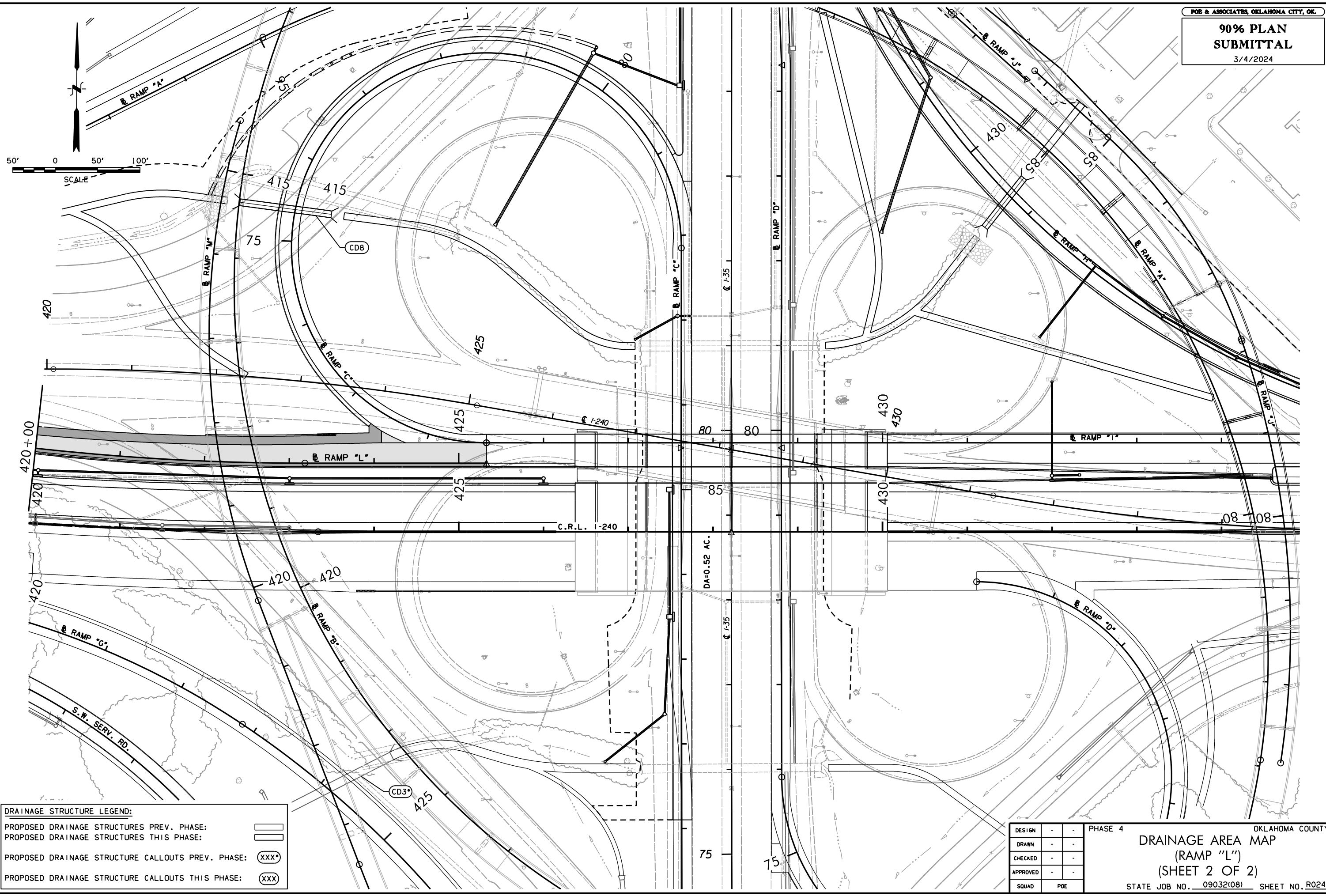
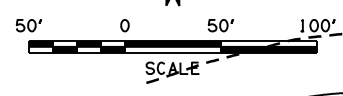

3/4/2024 2:36:24 PM
H:\PROJECTS\2789_Crossroads_Phase 4\Roadway\Drawings\0903208-Phase 4_DA.20.Ramp.L.2.dgn

DRAINAGE STRUCTURE LEGEND:

PROPOSED DRAINAGE STRUCTURES PREV. PHASE:	
PROPOSED DRAINAGE STRUCTURES THIS PHASE:	
PROPOSED DRAINAGE STRUCTURE CALLOUTS PREV. PHASE:	(XXX)
PROPOSED DRAINAGE STRUCTURE CALLOUTS THIS PHASE:	(XXX)

DESIGN	-	-	PHASE 4
DRAWN	-	-	
CHECKED	-	-	
APPROVED	-	-	
SQUAD	POE		

OKLAHOMA COUNTY

**DRAINAGE AREA MAP
(RAMP "L")
(SHEET 2 OF 2)**

STATE JOB NO. 090321081 SHEET NO. R024

3/4/2024 2:36:26 PM H:\PROJECTS\2789_CrossRoads_Phase 4\Roadway\Drawings\0903208-Phase 4_DA_21_NNE_SERV_RD_1.dgn

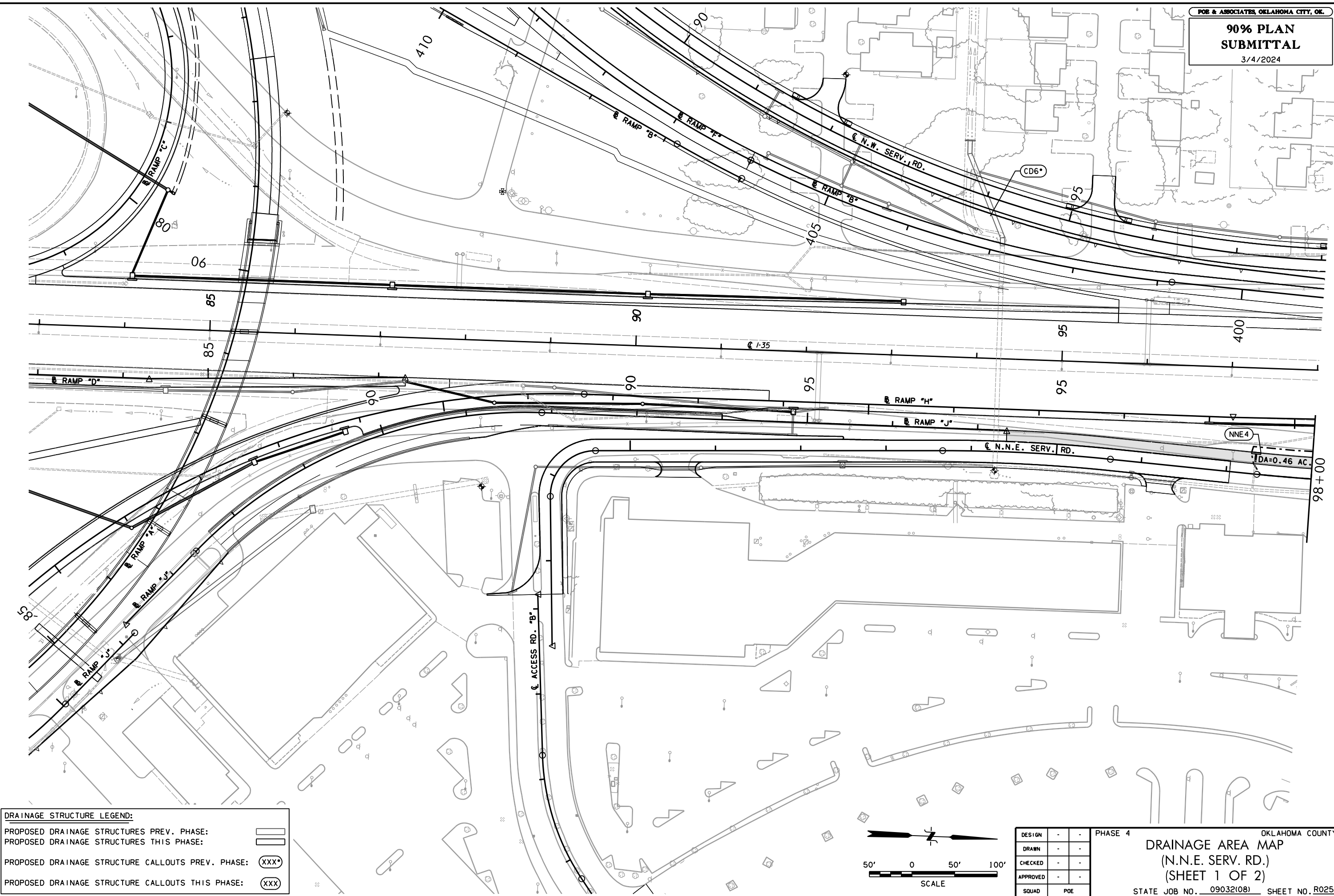

DRAINAGE STRUCTURE LEGEND:

PROPOSED DRAINAGE STRUCTURES PREV. PHASE:	
PROPOSED DRAINAGE STRUCTURES THIS PHASE:	
PROPOSED DRAINAGE STRUCTURE CALLOUTS PREV. PHASE:	(XXX)
PROPOSED DRAINAGE STRUCTURE CALLOUTS THIS PHASE:	(XXX)

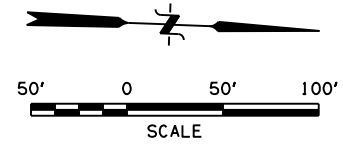

DESIGN	-	-
DRAWN	-	-
CHECKED	-	-
APPROVED	-	-
SQUAD	POE	

PHASE 4
 OKLAHOMA COUNTY
DRAINAGE AREA MAP
 (N.N.E. SERV. RD.)
 (SHEET 1 OF 2)
 STATE JOB NO. 090321081 SHEET NO. R025

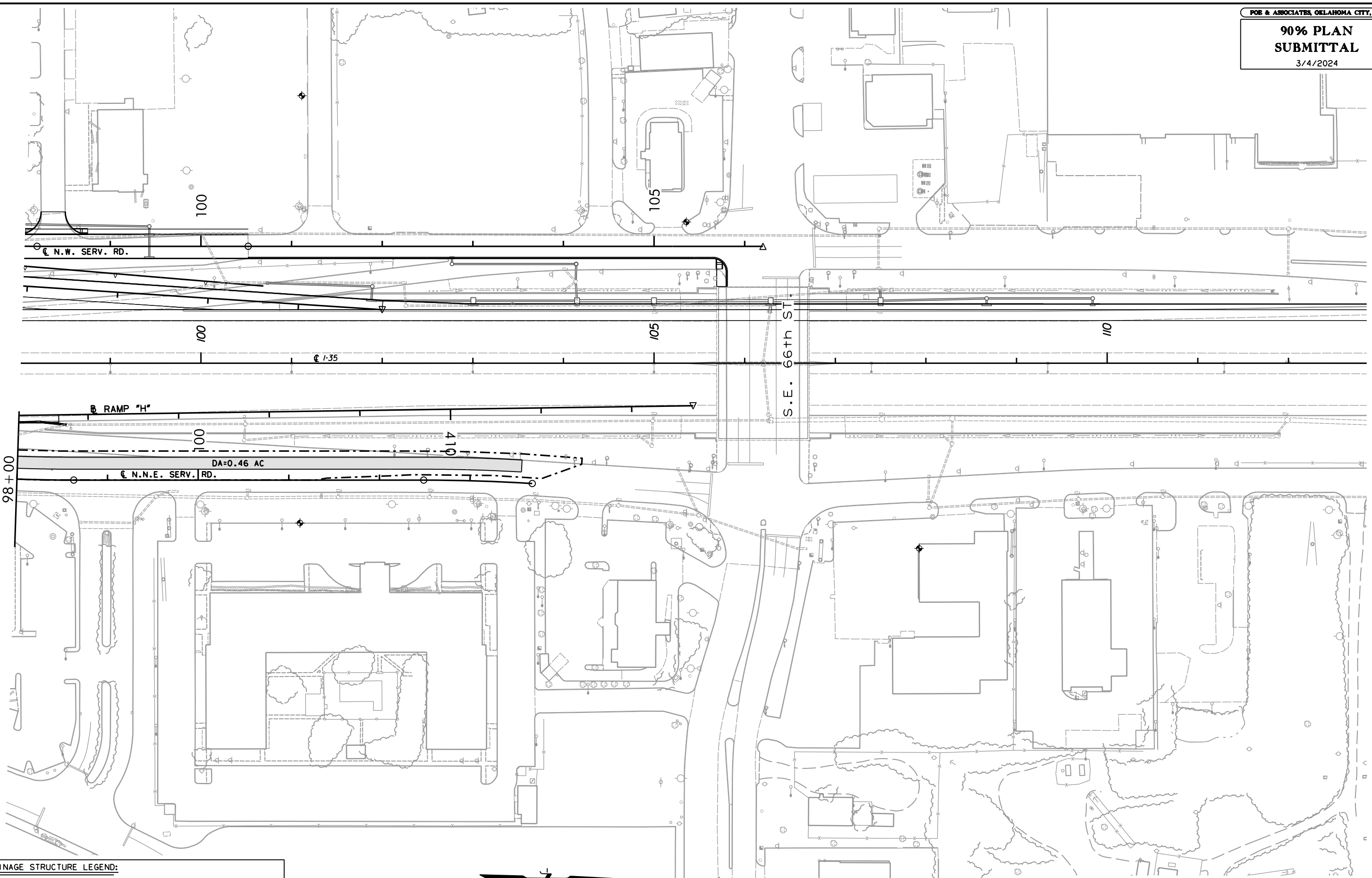

3/4/2024 2:36:28 PM H:\PROJECTS\2789_Crossroads_Phase 4\Roadway\Drawings\0903208-Phase 4_DA.22.NNE.SERV.RD_2.dgn

DRAINAGE STRUCTURE LEGEND:

PROPOSED DRAINAGE STRUCTURES PREV. PHASE:	
PROPOSED DRAINAGE STRUCTURES THIS PHASE:	
PROPOSED DRAINAGE STRUCTURE CALLOUTS PREV. PHASE:	(XXX)
PROPOSED DRAINAGE STRUCTURE CALLOUTS THIS PHASE:	(XXX)

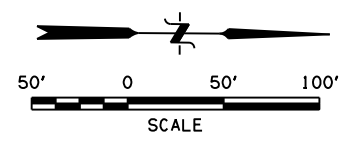

DESIGN	-	-
DRAWN	-	-
CHECKED	-	-
APPROVED	-	-
SQUAD	POE	

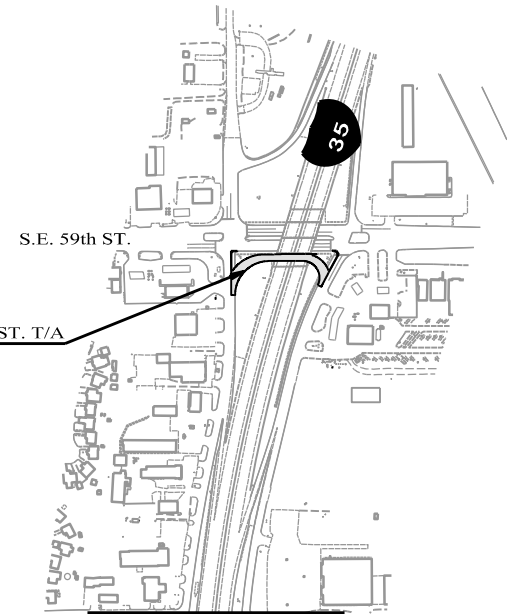
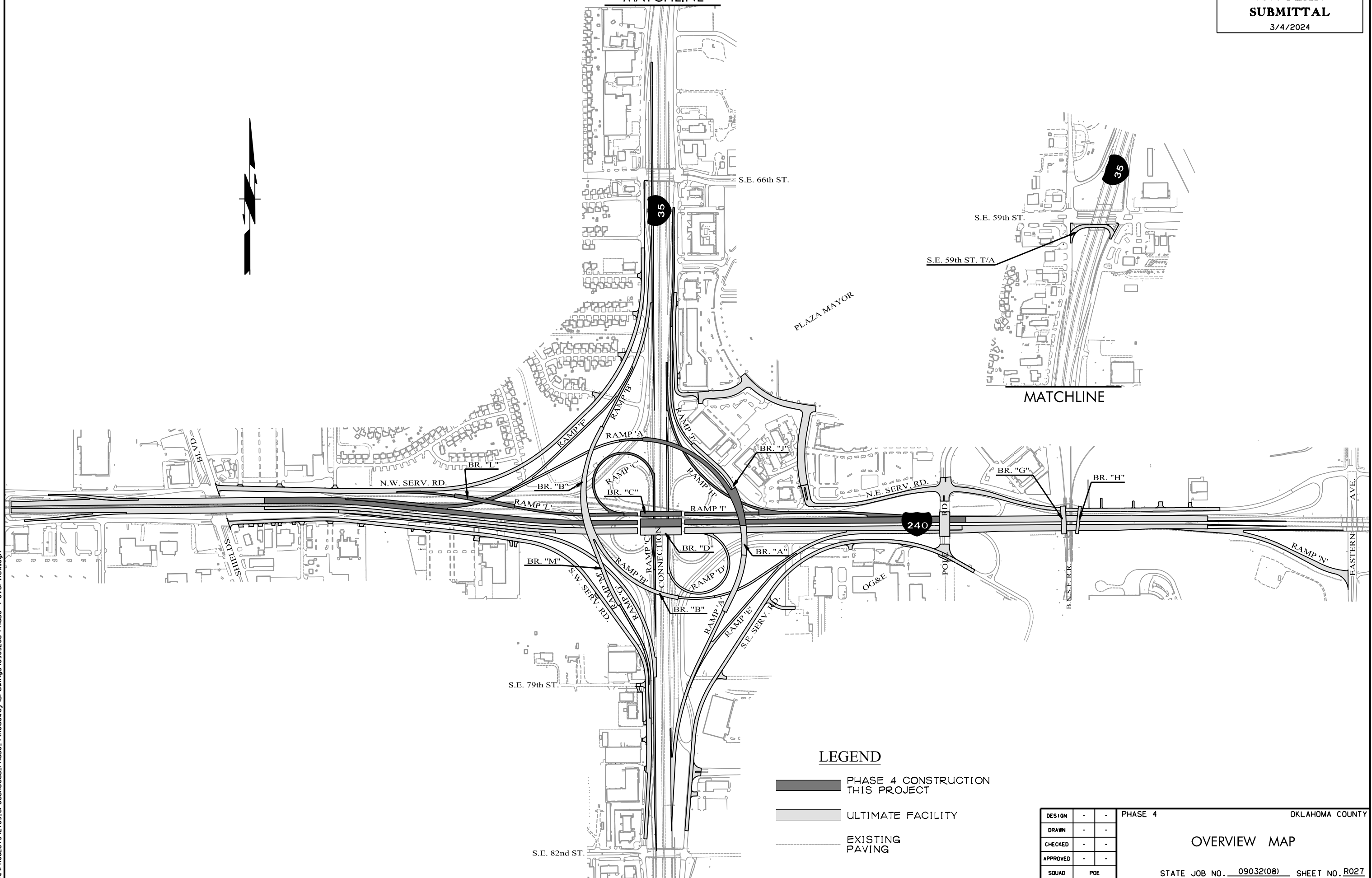

PHASE 4
OKLAHOMA COUNTY
DRAINAGE AREA MAP
(N.N.E. SERV. RD.)
(SHEET 2 OF 2)
STATE JOB NO. 09032108 SHEET NO. R026

MATCHLINE



MATCHLINE

LEGEND

-  PHASE 4 CONSTRUCTION THIS PROJECT
-  ULTIMATE FACILITY
-  EXISTING PAVING

DESIGN	-	-	PHASE 4	OKLAHOMA COUNTY
DRAWN	-	-	OVERVIEW MAP	
CHECKED	-	-		
APPROVED	-	-		
SQUAD	POE			
			STATE JOB NO. 090321081	SHEET NO. R027

3/4/2024 2:36:30 PM H:\PROJECTS\2789_CrossRoads_Phase 4\Roadway\Drawings\0903208-Phase 4-OverView.dgn

GENERAL SEQUENCE OF CONSTRUCTION

PART 1

SHIFT NORTHBOUND AND SOUTHBOUND I35 TRAFFIC TOWARDS RESPECTIVE EXTERIOR SHOULDERS FROM STA 74+00.00 TO STA 85+00.00. CONSTRUCT PIERS FOR BRIDGE "D". RESTRICT WESTBOUND I240 TRAFFIC TO TWO EXTERIOR LANES ALONG EXISTING ALIGNMENT FROM STA 391+85.00 TO STA 458+41.00. CONSTRUCT INTERIOR LANES AND SHOULDER OF WESTBOUND I240 FROM STA 397+20.00 TO STA 408+56.00 AND FROM STA 430+05.00 TO STA 452+00.00 ON NEW ALIGNMENT, FULL WIDTH OF NEW ALIGNMENT FROM STA 408+56.00 TO STA 430+05.00 INCLUDING BRIDGE "D" DECK. COMPLETE.

PART 2

SHIFT NORTHBOUND I35 TRAFFIC TOWARDS EXTERIOR SHOULDER FROM STA 74+00.00 TO STA 81+80.00 THEN SHIFT TO INTERIOR SHOULDER FROM STA 84+00.00 TO STA 100+00.00. CONSTRUCT PIERS AND DECK FOR BRIDGE "C". SHIFT SOUTHBOUND I35 TRAFFIC TO INTERIOR SHOULDER FROM STA 73+50.00 TO STA 98+79.00. CLOSE EXISTING WESTBOUND I240 TO NORTHBOUND I35 RAMP. CLOSE EXISTING WESTBOUND I240 TO SOUTHBOUND I35 RAMP. CLOSE EXISTING NORTHBOUND I35 TO WESTBOUND I240 RAMP. SHIFT AND RESTRICT WESTBOUND I240 TRAFFIC TO TWO INTERIOR LANES ALONG NEW ALIGNMENT FROM STA 392+41.00 TO STA 459+81.00. CONSTRUCT WESTBOUND I240 EXTERIOR LANES AND SHOULDER FROM STA 397+25.00 TO STA 408+56.00 AND STA 430+05.00 TO STA 452+00.00. CONSTRUCT RAMP "H" FROM STA 414+32.00 TO STA 449+30.83. CONSTRUCT RAMP "I" FROM STA 425+32.69 TO STA 438+36.46. CONSTRUCT RAMP "L" FROM STA 407+47.18 TO STA 425+32.69 INCLUDING PIERS AND DECK FOR BRIDGE "L". CONSTRUCT RAMP "C" FROM STA 71+30.93 TO STA 94+13.47. CONSTRUCT PIERS AND DECK FOR BRIDGE "A" FROM STA 79+78.00 TO STA 92+50.00. CONSTRUCT NE SERVICE ROAD FROM STA 94+41.00 TO STA 103+56.13.

PART 3

OPEN FULL WIDTH OF NEW ALIGNMENT FOR WESTBOUND I240 TO TRAFFIC

NOTE: FALSE WORK SHALL BE USED WHEN CONSTRUCTING ANY BRIDGE OVER ACTIVE TRAFFIC.

MATCHLINE

MATCHLINE

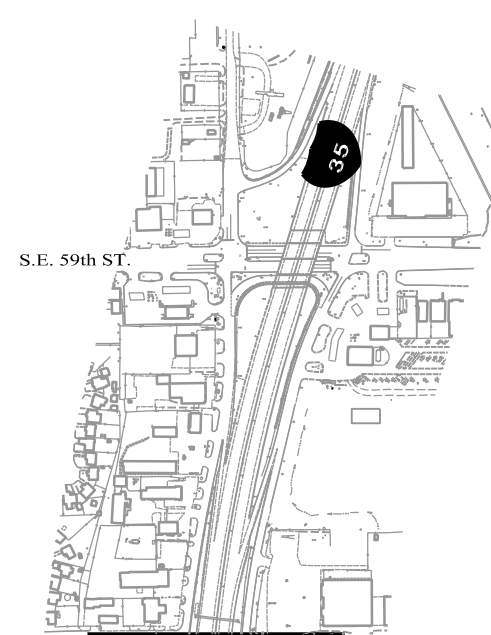
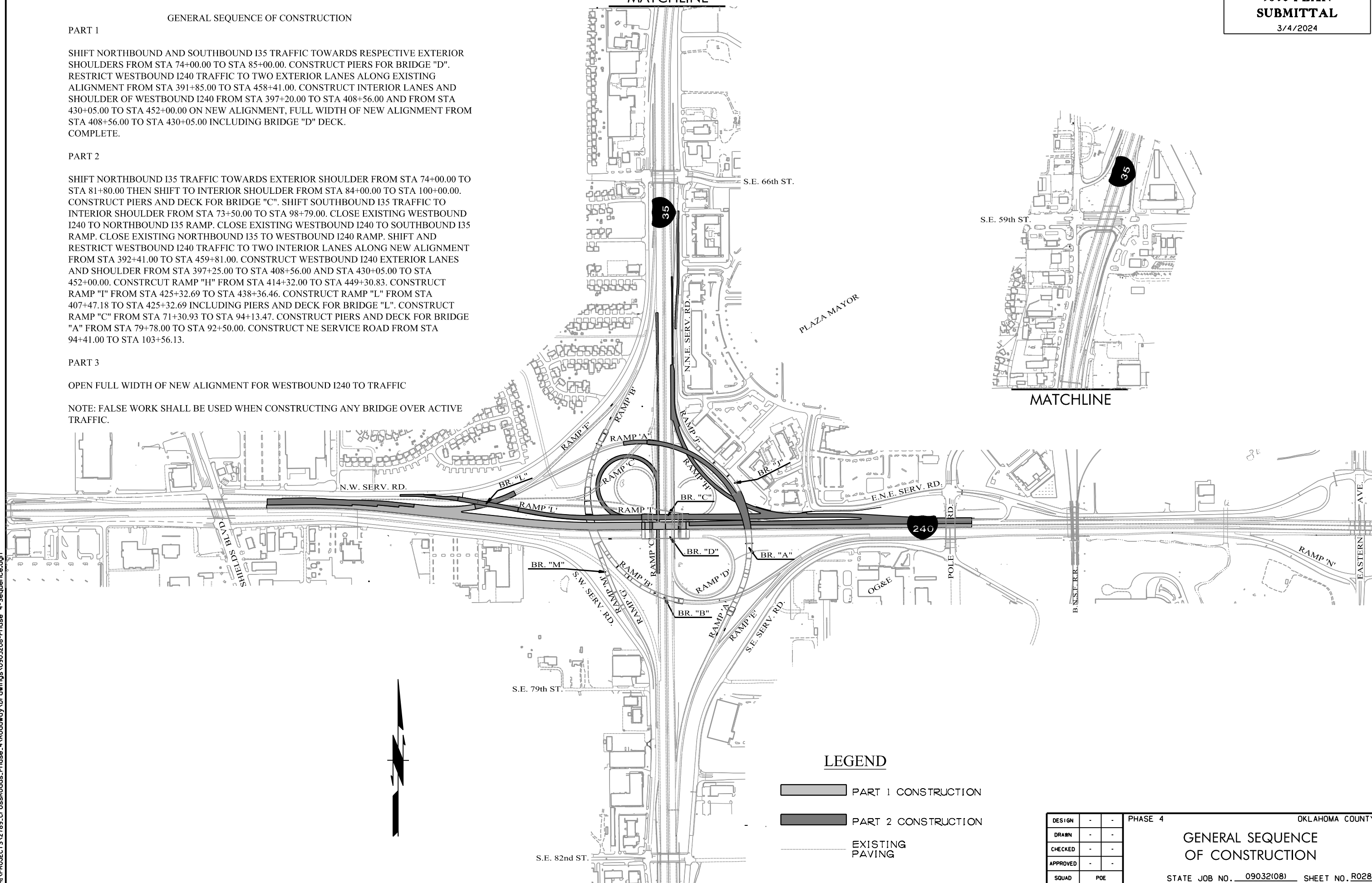

LEGEND

- PART 1 CONSTRUCTION
- PART 2 CONSTRUCTION
- EXISTING PAVING

DESIGN	-	-
DRAWN	-	-
CHECKED	-	-
APPROVED	-	-
SQUAD	POE	

PHASE 4	OKLAHOMA COUNTY
GENERAL SEQUENCE OF CONSTRUCTION	
STATE JOB NO. 090321081	SHEET NO. R028

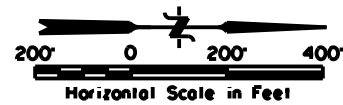

2030 ADT

K=9%
D=55%
T(dhv)6%
T(adt)10%
T(3)7%
AXLES15

SEC. 34. T11N. R3W

SEC. 27. T11N. R3W

SEC. 35. T11N. R3W

SEC. 26. T11N. R3W

MATCH LINE 2 SEE NEXT SHEET

MATCH LINE 3

MATCH LINE 1

MATCH LINE 1

2:36:36 PM H:\PROJECTS\2789_CrossRoads_Phase 4\Roadway\Drawings\0903208-Phase 4-Traffic.dgn

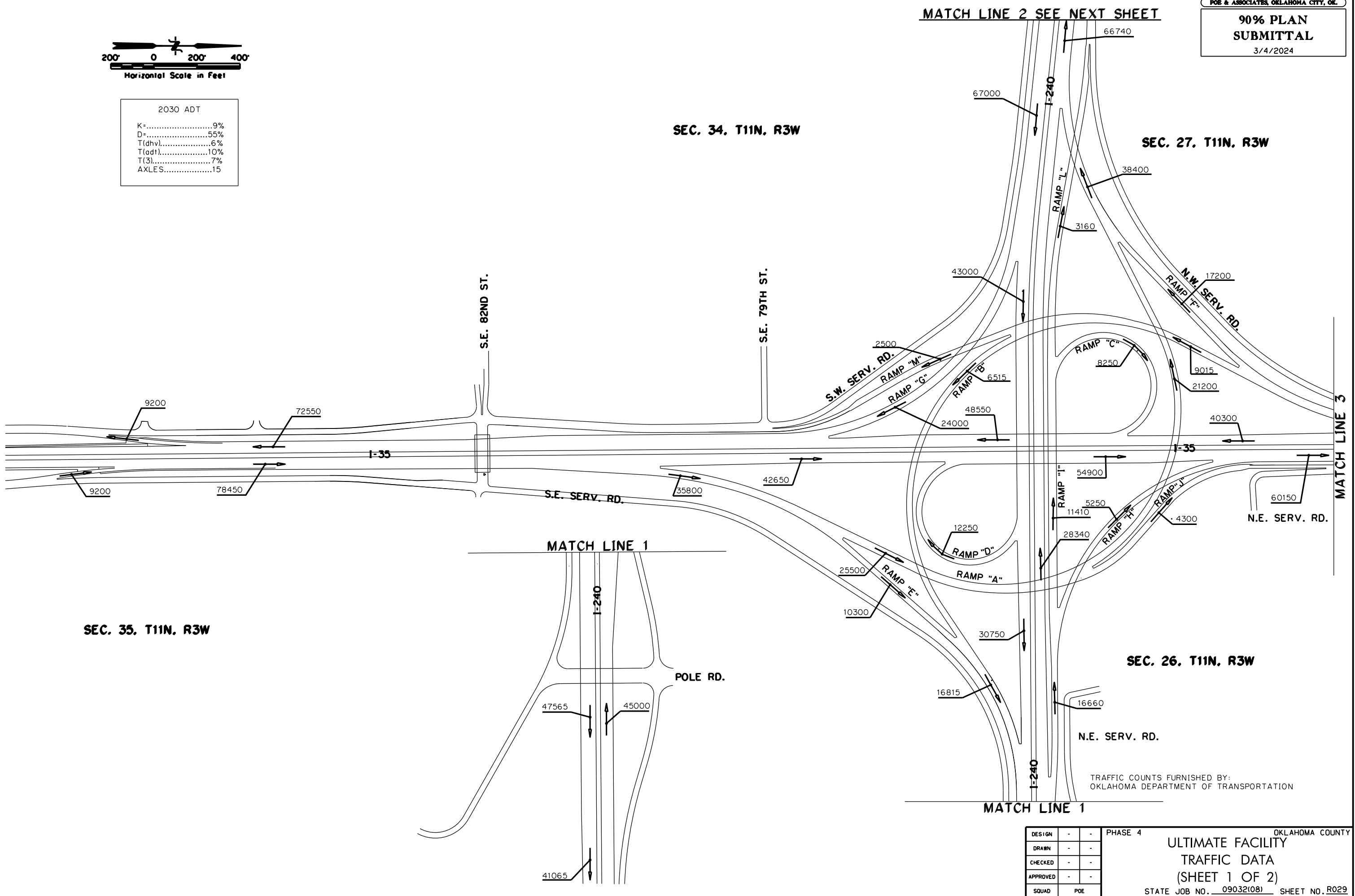

TRAFFIC COUNTS FURNISHED BY:
OKLAHOMA DEPARTMENT OF TRANSPORTATION

DESIGN	-	-
DRAWN	-	-
CHECKED	-	-
APPROVED	-	-
SQUAD	POE	

PHASE 4
OKLAHOMA COUNTY
ULTIMATE FACILITY
TRAFFIC DATA
(SHEET 1 OF 2)
STATE JOB NO. 090321081 SHEET NO. R029

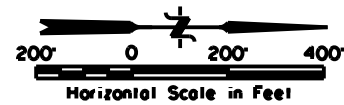

SEC. 27. T11N. R3W

SEC. 22. T11N. R3W

SEC. 26. T11N. R3W

SEC. 23. T11N. R3W

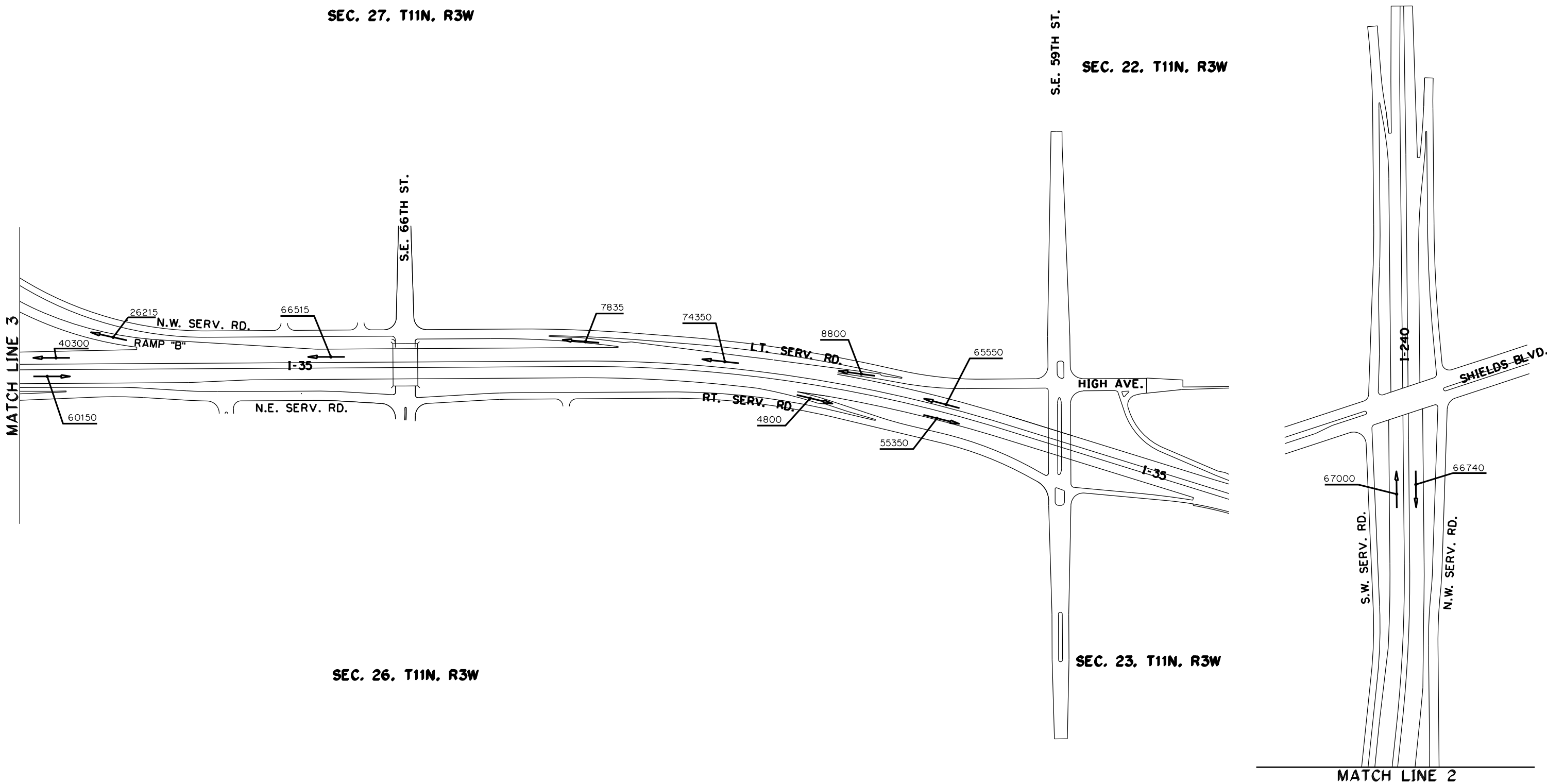

TRAFFIC COUNTS FURNISHED BY:
OKLAHOMA DEPARTMENT OF TRANSPORTATION

DESIGN	-	-
DRAWN	-	-
CHECKED	-	-
APPROVED	-	-
SQUAD	POE	

PHASE 4
OKLAHOMA COUNTY
**ULTIMATE FACILITY
TRAFFIC DATA
(SHEET 2 OF 2)**
STATE JOB NO. 09032108 SHEET NO. R030

2:36:37 PM H:\PROJECTS\2789_CrossRoads_Phase 4\Roadway\Drawings\0903208-Phase 4-Traffic\dat2.dgn

MATCH LINE 3

MATCH LINE 2

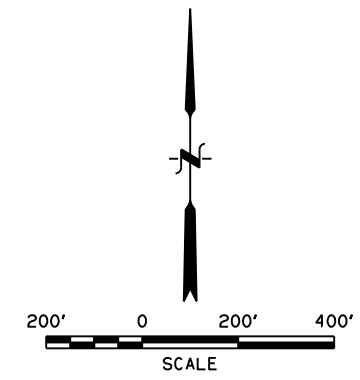
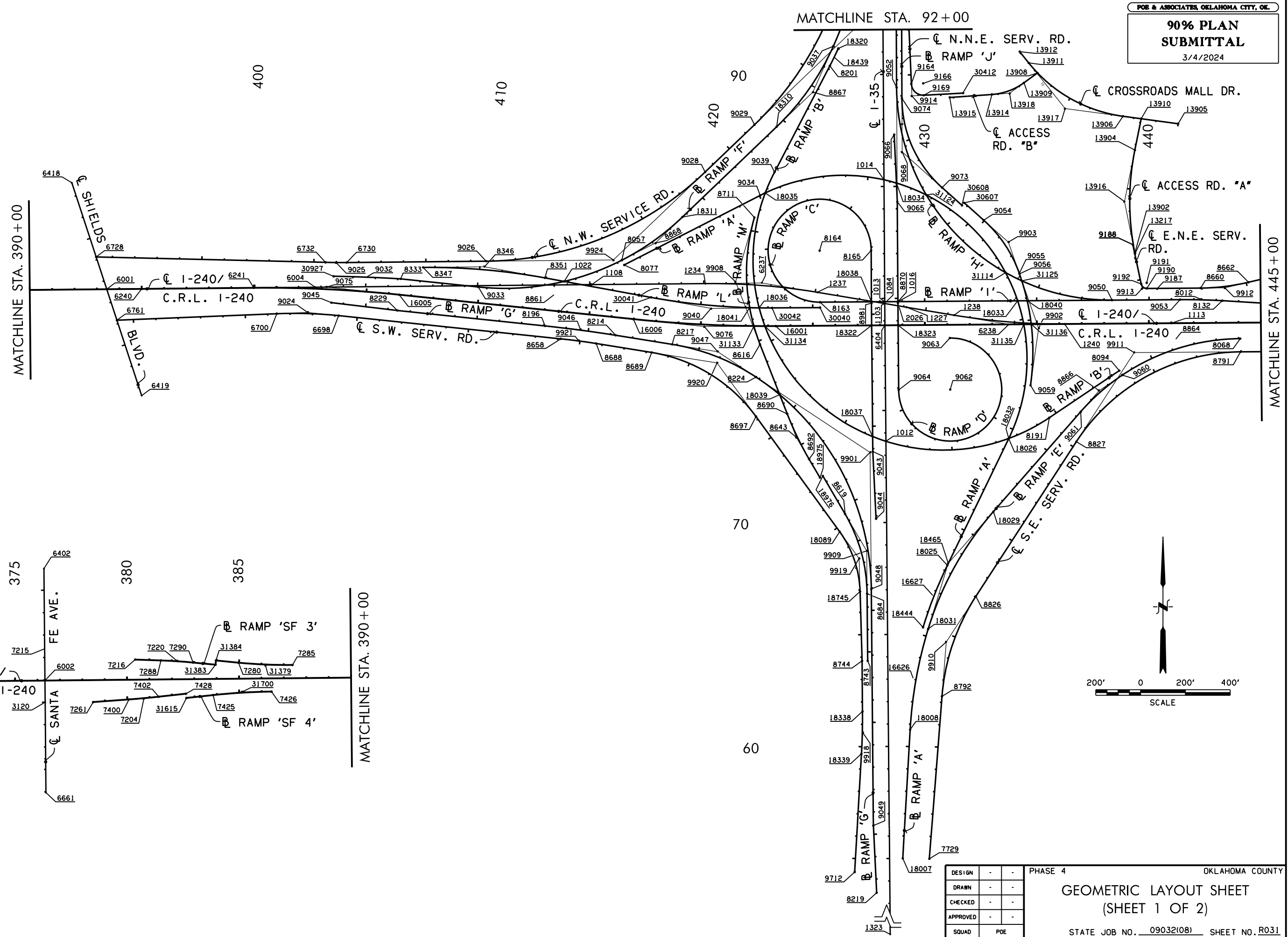

DESIGN	-	-	PHASE 4	OKLAHOMA COUNTY
DRAWN	-	-	GEOMETRIC LAYOUT SHEET (SHEET 1 OF 2)	
CHECKED	-	-		
APPROVED	-	-		
SQUAD	POE		STATE JOB NO. 090321081	SHEET NO. R031

3/4/2024 2:36:38 PM
 H:\PROJECTS\2789_CrossRoads_Phase 4\Roadway\Drawings\0903208-Phase 4 GeolayA.dgn

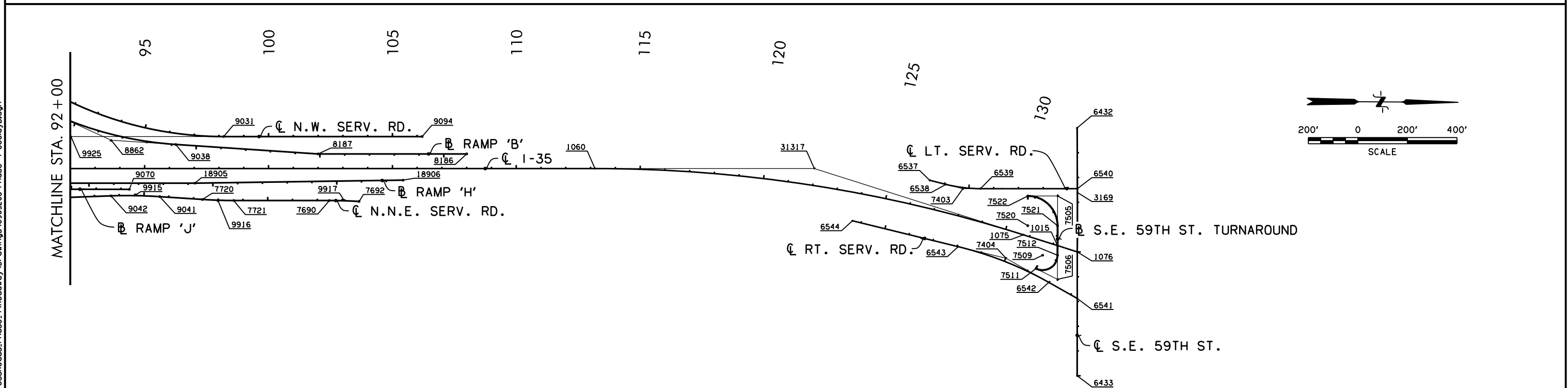
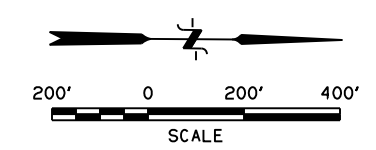
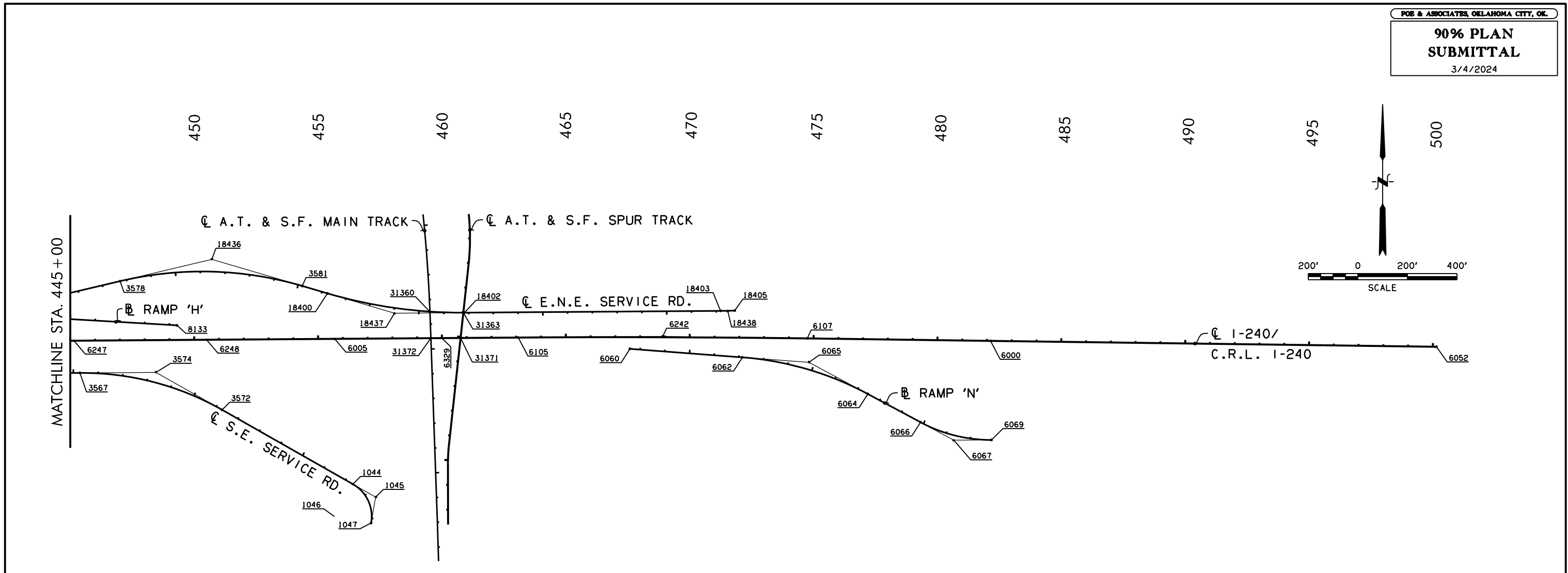
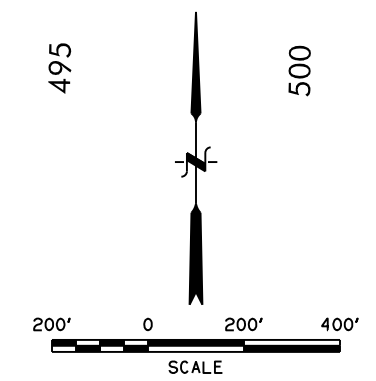

3/4/2024 2:36:38 PM H:\PROJECTS\2789_CrossRoads_Phase 4\Roadway\Drawings\0903208-Phase 4 GeologyB.dgn

DESIGN	-	-
DRAWN	-	-
CHECKED	-	-
APPROVED	-	-
SQUAD	POE	

PHASE 4
OKLAHOMA COUNTY
GEOMETRIC LAYOUT SHEET
(SHEET 2 OF 2)
STATE JOB NO. 090321081 SHEET NO. R032

C.R.L. I-240 (E.B. & W.B.)

V= 60 M.P.H., e Max= 8.00%

Table with columns: POINT, STATION, NORTHING, EASTING. Rows include P.O.B. STA., P.O.T. STA., P.I. STA., P.O.C. STA., C.C. STA., P.T. STA., and CURVE C-1 through C-2.

C.R.L. I-240 (E.B. & W.B., CONT'D.)

V= 60 M.P.H., e Max= 8.00%

Table with columns: POINT, STATION, NORTHING, EASTING. Rows include P.O.T. STA., P.O.C. STA., P.T. STA., and CURVE C-3.

C/L I-35 (N.B. & S.B.)

V= 60 M.P.H., e Max= 8.00%

Table with columns: POINT, STATION, NORTHING, EASTING. Rows include P.O.B. STA., P.O.T. STA., P.O.C. STA., P.I. STA., P.T. STA., and CURVE C-4.

3/4/2024 2:36:44 PM H:\PROJECTS\2789_Cr-osaroads_Phase 4\Roadway\Drawings\0903208-Phase 4_COGO_Points-2.dgn

PHASE 4 OKLAHOMA COUNTY
GEOMETRIC COORDINATE
POINT TABLES
(SHEET 2 OF 12)
STATE JOB NO. 09032108 SHEET NO. R034

B/L RAMP SF-3

V= 45 M.P.H., e Max= 6.00%

Table with 5 columns: POINT, STATION, NORTHING, EASTING. Includes data for P.O.B. STA., P.O.T. STA., P.C. STA., TANGENTIAL DIRECTION, TANGENTIAL LENGTH, CURVE SF3-1, and P.T. STA.

B/L RAMP SF-4

V= 45 M.P.H., e Max= 6.00%

Table with 5 columns: POINT, STATION, NORTHING, EASTING. Includes data for P.O.B. STA., P.O.T. STA., P.C. STA., TANGENTIAL DIRECTION, TANGENTIAL LENGTH, CURVE SF4-1, and P.T. STA.

B/L S.E. 59TH ST. TURNAROUND

V= 25 M.P.H.

Table with 5 columns: POINT, STATION, NORTHING, EASTING. Includes data for CURVE 59T-1, P.C. STA./P.O.B. STA., P.O.C. STA., P.O.T. STA., P.I. STA., C.C. STA., P.T. STA., RADIUS, DELTA, DEGREE OF CURVATURE, LENGTH, TANGENT, CHORD, MIDDLE ORDINATE, EXTERNAL, TANGENT DIRECTION, RADIAL DIRECTION, CHORD DIRECTION, RADIAL DIRECTION, TANGENT DIRECTION, P.T. STA., P.C. STA., TANGENTIAL DIRECTION, TANGENTIAL LENGTH, CURVE 59T-2, P.C. STA., P.I. STA., C.C. STA., P.T. STA./P.O.E. STA., P.O.T. STA., P.O.C. STA., RADIUS, DELTA, DEGREE OF CURVATURE, LENGTH, TANGENT, CHORD, MIDDLE ORDINATE, EXTERNAL, TANGENT DIRECTION, RADIAL DIRECTION, CHORD DIRECTION, RADIAL DIRECTION, TANGENT DIRECTION.

3/4/2024 2:36:49 PM H:\PROJECTS\2789_Crossroads_Phase 4\Roadway\Drawings\0903208-Phase 4_COGO_Points_3.dgn

Table with 2 columns: DESIGN, DRAWN, CHECKED, APPROVED, SQUAD. Includes PHASE 4, GEOMETRIC COORDINATE POINT TABLES (SHEET 3 OF 12), STATE JOB NO. 09032108, SHEET NO. R035.

90% PLAN SUBMITTAL

3/4/2024

B/L RAMP "B" (S.B. I-35 TO E.B. I-240, CONT'D.)

V= 50 M.P.H., e Max= 6.00%

Table with columns: POINT, STATION, NORTHING, EASTING. Includes data for CURVE RB-3, P.C. STA., P.O.C. STA., P.O.T. STA., RADIUS, DELTA, DEGREE OF CURVATURE (ARC), LENGTH, TANGENT, CHORD, MIDDLE ORDINATE, EXTERNAL, TANGENT DIRECTION, RADIAL DIRECTION, CHORD DIRECTION, RADIAL DIRECTION, TANGENT DIRECTION, P.T. STA., P.O.T. STA., TANGENTIAL DIRECTION, TANGENTIAL LENGTH, P.O.T. STA., P.C. STA. B/L SHIFT 24.00' RT., P.T. STA./P.O.E. STA.

B/L RAMP "C" (W.B. I-240 TO S.B. I-35, CONT'D.)

V= 30 M.P.H., e Max= 6.00%

Table with columns: POINT, STATION, NORTHING, EASTING. Includes data for RADIUS, DELTA, DEGREE OF CURVATURE (ARC), LENGTH, TANGENT, CHORD, MIDDLE ORDINATE, EXTERNAL, TANGENT DIRECTION, RADIAL DIRECTION, CHORD DIRECTION, RADIAL DIRECTION, TANGENT DIRECTION, P.T. STA., P.O.T. STA., P.O.T. STA., P.I. STA., TANGENTIAL DIRECTION, TANGENTIAL LENGTH, P.I. STA., P.O.T. STA., P.O.T. STA., P.O.T. STA., P.O.C. STA., P.I. STA., TANGENTIAL DIRECTION, TANGENTIAL LENGTH, P.I. STA., P.O.E. STA., P.O.T. STA., TANGENTIAL DIRECTION, TANGENTIAL LENGTH.

B/L RAMP "D" (E.B. I-240 TO N.B. I-35, CONT'D.)

V= 30 M.P.H., e Max= 6.00%

Table with columns: POINT, STATION, NORTHING, EASTING. Includes data for P.I. STA., P.O.T. STA., P.O.C. STA., P.O.E. STA., P.O.T. STA., TANGENTIAL DIRECTION, TANGENTIAL LENGTH.

B/L RAMP "E" (N.B. I-35 TO E.B. I-240)

V= 45 M.P.H., e Max= 6.00%

Table with columns: POINT, STATION, NORTHING, EASTING. Includes data for CURVE RE-1, P.C. STA./P.O.B. STA., P.T. STA., P.I. STA., C.C. STA., P.T. STA., RADIUS, DELTA, DEGREE OF CURVATURE (ARC), LENGTH, TANGENT, CHORD, MIDDLE ORDINATE, EXTERNAL, TANGENT DIRECTION, RADIAL DIRECTION, CHORD DIRECTION, RADIAL DIRECTION, TANGENT DIRECTION, P.T. STA., P.C. STA., TANGENTIAL DIRECTION, TANGENTIAL LENGTH, CURVE RE-2, P.C. STA., P.I. STA., C.C. STA., P.T. STA./P.O.E. STA., P.C. STA., RADIUS, DELTA, DEGREE OF CURVATURE (ARC), LENGTH, TANGENT, CHORD, MIDDLE ORDINATE, EXTERNAL, TANGENT DIRECTION, RADIAL DIRECTION, CHORD DIRECTION, RADIAL DIRECTION, TANGENT DIRECTION.

B/L RAMP "D" (E.B. I-240 TO N.B. I-35)

V= 30 M.P.H., e Max= 6.00%

Table with columns: POINT, STATION, NORTHING, EASTING. Includes data for CURVE RD-1, P.C. STA./P.O.B. STA., P.O.T. STA., C.C. STA., P.T. STA., RADIUS, DELTA, DEGREE OF CURVATURE (ARC), LENGTH, TANGENT, CHORD, MIDDLE ORDINATE, EXTERNAL, TANGENT DIRECTION, RADIAL DIRECTION, CHORD DIRECTION, RADIAL DIRECTION, TANGENT DIRECTION, P.T. STA., P.O.T. STA., P.O.T. STA., P.O.T. STA., P.I. STA., TANGENTIAL DIRECTION, TANGENTIAL LENGTH, P.I. STA., P.O.T. STA., P.O.T. STA., P.I. STA., TANGENTIAL DIRECTION, TANGENTIAL LENGTH.

B/L RAMP "C" (W.B. I-240 TO S.B. I-35)

V= 30 M.P.H., e Max= 6.00%

Table with columns: POINT, STATION, NORTHING, EASTING. Includes data for CURVE RC-1, P.C. STA./P.O.B. STA., P.O.T. STA., P.O.B. STA., C.C. STA., P.T. STA.

PHASE 4 OKLAHOMA COUNTY GEOMETRIC COORDINATE POINT TABLES (SHEET 5 OF 12) STATE JOB NO. 09032108 SHEET NO. R037

90% PLAN SUBMITTAL

3/4/2024

C/L E.N.E. SERV. RD. (CONT'D.)

V= 40 M.P.H., e Max= 8.00%

Table with columns: POINT, STATION, NORTHING, EASTING. Rows include curve data (CURVE ENE-2, ENE-3, ENE-4), P.C. STA., P.O.C. STA., P.O.T. STA., P.I. STA., C.C. STA., P.T. STA., RADIUS, DELTA, DEGREE OF CURVATURE (ARC), LENGTH, TANGENT, CHORD, MIDDLE ORDINATE, EXTERNAL, TANGENT DIRECTION, RADIAL DIRECTION, CHORD DIRECTION, RADIAL DIRECTION, TANGENT DIRECTION.

C/L E.N.E. SERV. RD. (CONT'D.)

V= 40 M.P.H., e Max= 8.00%

Table with columns: POINT, STATION, NORTHING, EASTING. Rows include P.T. STA., P.C. STA., TANGENTIAL DIRECTION, TANGENTIAL LENGTH, CURVE ENE-5, P.C. STA., P.I. STA., C.C. STA., P.T. STA., RADIUS, DELTA, DEGREE OF CURVATURE (ARC), LENGTH, TANGENT, CHORD, MIDDLE ORDINATE, EXTERNAL, TANGENT DIRECTION, RADIAL DIRECTION, CHORD DIRECTION, RADIAL DIRECTION, TANGENT DIRECTION.

C/L N.N.E. SERV. RD.

V= 40 M.P.H., e Max= 8.00%

Table with columns: POINT, STATION, NORTHING, EASTING. Rows include P.O.B. STA., P.O.T. STA., P.C. STA., TANGENTIAL DIRECTION, TANGENTIAL LENGTH, CURVE NNE-1, P.C. STA., P.I. STA., C.C. STA., P.T. STA., RADIUS, DELTA, DEGREE OF CURVATURE (ARC), LENGTH, TANGENT, CHORD, MIDDLE ORDINATE, EXTERNAL, TANGENT DIRECTION, RADIAL DIRECTION, CHORD DIRECTION, RADIAL DIRECTION, TANGENT DIRECTION.

C/L N.N.E. SERV. RD. (CONT'D.)

V= 40 M.P.H., e Max= 8.00%

Table with columns: POINT, STATION, NORTHING, EASTING. Rows include RADIUS, DELTA, DEGREE OF CURVATURE (ARC), LENGTH, TANGENT, CHORD, MIDDLE ORDINATE, EXTERNAL, TANGENT DIRECTION, RADIAL DIRECTION, CHORD DIRECTION, RADIAL DIRECTION, TANGENT DIRECTION, P.T. STA., P.C. STA., TANGENTIAL DIRECTION, TANGENTIAL LENGTH, CURVE NNE-3, P.C. STA., P.I. STA., C.C. STA., P.T. STA., RADIUS, DELTA, DEGREE OF CURVATURE (ARC), LENGTH, TANGENT, CHORD, MIDDLE ORDINATE, EXTERNAL, TANGENT DIRECTION, RADIAL DIRECTION, CHORD DIRECTION, RADIAL DIRECTION, TANGENT DIRECTION.

Design table with columns: DESIGN, DRAWN, CHECKED, APPROVED, SQUAD. Includes PHASE 4 GEOMETRIC COORDINATE POINT TABLES (SHEET 9 OF 12) and STATE JOB NO. 09032108 SHEET NO. R041.

3/4/2024 2:37:24 PM H:\PROJECTS\21789_Cr-osaRoads_Phase 4\Roadway\Drawings\09032108-Phase 4_COGO_Points.dgn

C/L N.W. SERV. RD.

V= 40 M.P.H., e Max= 8.00%

Table with columns: POINT, STATION, NORTHING, EASTING. Contains data for curve NW-1, NW-2, NW-3 and various station points (P.O.B. STA. to TANGENTIAL DIRECTION).

C/L N.W. SERV. RD. (CONT'D.)

V= 40 M.P.H., e Max= 8.00%

Table with columns: POINT, STATION, NORTHING, EASTING. Contains data for P.T. STA., P.O.E. STA., P.O.T. STA., TANGENTIAL DIRECTION, and TANGENTIAL LENGTH.

C/L S.E. SERV. RD.

V= 40 M.P.H., e Max= 8.00%

Table with columns: POINT, STATION, NORTHING, EASTING. Contains data for curve SE-1, SE-2, SE-3 and various station points (P.O.B. STA. to TANGENTIAL LENGTH).

C/L S.E. SERV. RD. (CONT'D.)

V= 40 M.P.H., e Max= 8.00%

Table with columns: POINT, STATION, NORTHING, EASTING. Contains data for curve SE-4 and various station points (P.T. STA. to TANGENTIAL LENGTH).

C/L POLE RD.

V= N.A. M.P.H., e Max= N.A.

Table with columns: POINT, STATION, NORTHING, EASTING. Contains data for P.O.B. STA., P.O.C. STA., P.O.E. STA., TANGENTIAL DIRECTION, and TANGENTIAL LENGTH.

PHASE 4 GEOMETRIC COORDINATE POINT TABLES (SHEET 10 OF 12) STATE JOB NO. 090321081 SHEET NO. R042. Includes design, draw, checked, approved, and squad checkboxes.

3/4/2024 2:37:30 PM H:\PROJECTS\21789_Cr-osaroads_Phase 4\Roadway\Drawings\09032108-Phase 4_COGO_Points.dgn

C/L ACCESS RD. "A"

V= N.A., e Max= N.A.

Table with columns: POINT, STATION, NORTHING, EASTING. Rows include P.O.B. STA., P.O.T. STA., P.C. STA., TANGENTIAL DIRECTION, TANGENTIAL LENGTH, CURVE ARA-1, and P.T. STA.

C/L LT. SERV. RD. AT S.E. 59TH ST.

V= N.A., e Max= N.A.

Table with columns: POINT, STATION, NORTHING, EASTING. Rows include P.O.B. STA., P.O.C. STA., P.C. STA., TANGENTIAL DIRECTION, TANGENTIAL LENGTH, CURVE LSR-1, and P.T. STA.

C/L SANTA FE AVE. (N.B. & S.B.)

V= N.A., e Max= N.A.

Table with columns: POINT, STATION, NORTHING, EASTING. Rows include P.O.B. STA., P.I. STA., TANGENTIAL DIRECTION, TANGENTIAL LENGTH, P.I. STA., P.I. STA., P.O.T. STA., P.O.T. STA., TANGENTIAL DIRECTION, TANGENTIAL LENGTH, P.I. STA., P.O.E. STA., TANGENTIAL DIRECTION, TANGENTIAL LENGTH.

C/L S. SHIELDS BLVD. (N.B. & S.B.)

V= N.A., e Max= N.A.

Table with columns: POINT, STATION, NORTHING, EASTING. Rows include P.O.B. STA., P.O.T. STA., P.O.E. STA., P.O.T. STA., P.O.T. STA., P.O.T. STA., P.O.T. STA., P.O.B. STA., P.O.E. STA., TANGENTIAL DIRECTION, TANGENTIAL LENGTH.

C/L ACCESS RD. "B"

V= N.A., e Max= N.A.

Table with columns: POINT, STATION, NORTHING, EASTING. Rows include P.O.B. STA., P.O.C. STA., P.C. STA., TANGENTIAL DIRECTION, TANGENTIAL LENGTH, CURVE ARB-1, and P.T. STA.

C/L RT. SERV. RD. AT S.E. 59TH. ST.

V= N.A., e Max= N.A.

Table with columns: POINT, STATION, NORTHING, EASTING. Rows include P.O.B. STA., P.O.C. STA., P.C. STA., TANGENTIAL DIRECTION, TANGENTIAL LENGTH, CURVE RSR-1, and P.T. STA.

C/L S.E. 59TH ST. (E.B. & W.B.)

V= N.A., e Max= N.A.

Table with columns: POINT, STATION, NORTHING, EASTING. Rows include P.O.B. STA., P.O.T. STA., P.O.E. STA., P.I. STA., TANGENTIAL DIRECTION, TANGENTIAL LENGTH, P.I. STA., P.I. STA., P.O.E. STA., TANGENTIAL DIRECTION, TANGENTIAL LENGTH, P.I. STA., P.O.T. STA., P.O.E. STA., P.O.E. STA., TANGENTIAL DIRECTION, TANGENTIAL LENGTH.

Table with columns: DESIGN, DRAWN, CHECKED, APPROVED, SQUAD, POE.

PHASE 4 OKLAHOMA COUNTY GEOMETRIC COORDINATE POINT TABLES (SHEET 12 OF 12) STATE JOB NO. 09032108 SHEET NO. R044

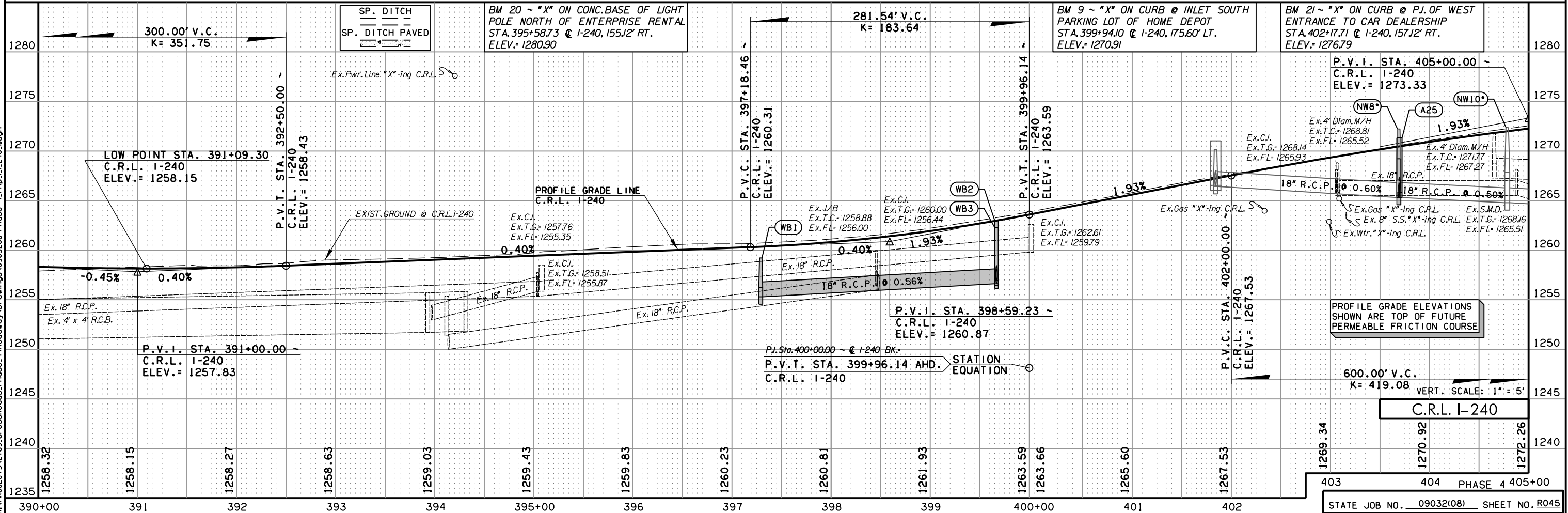
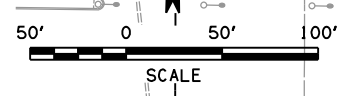
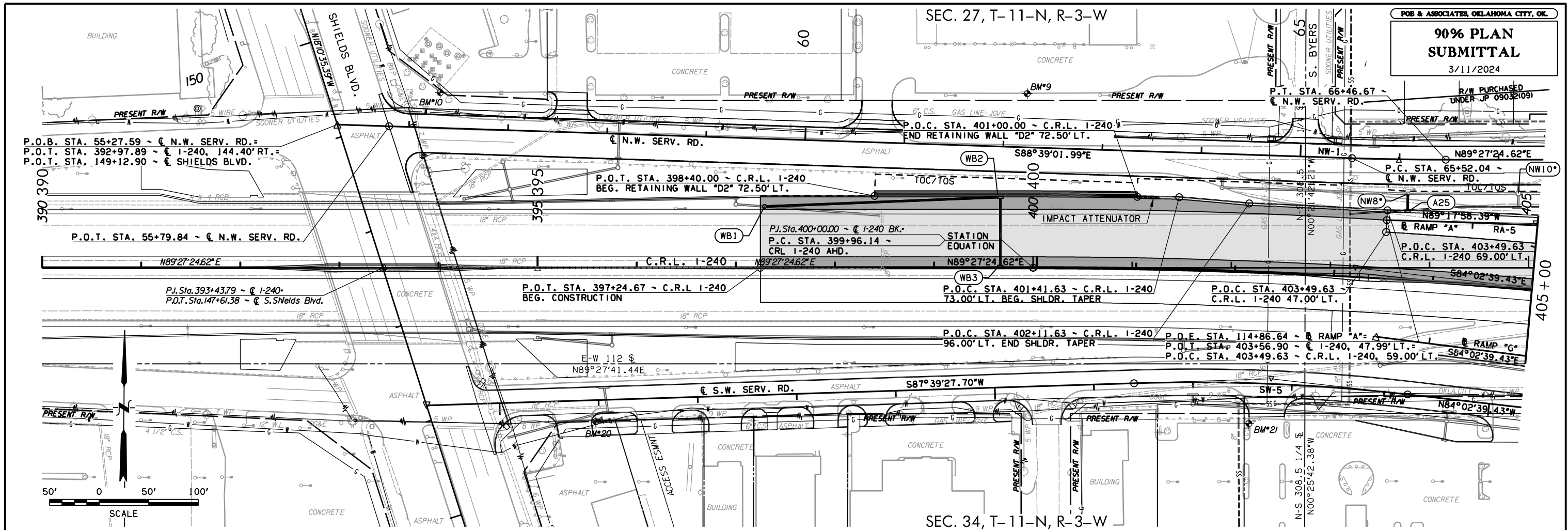

3/11/2024 7:44:58 PM H:\PROJECTS\2789_CrossRoads_Phase 4\Roadway\Drawings\0903208-Phase 4\Prop.L.I-240.L.dgn

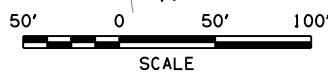
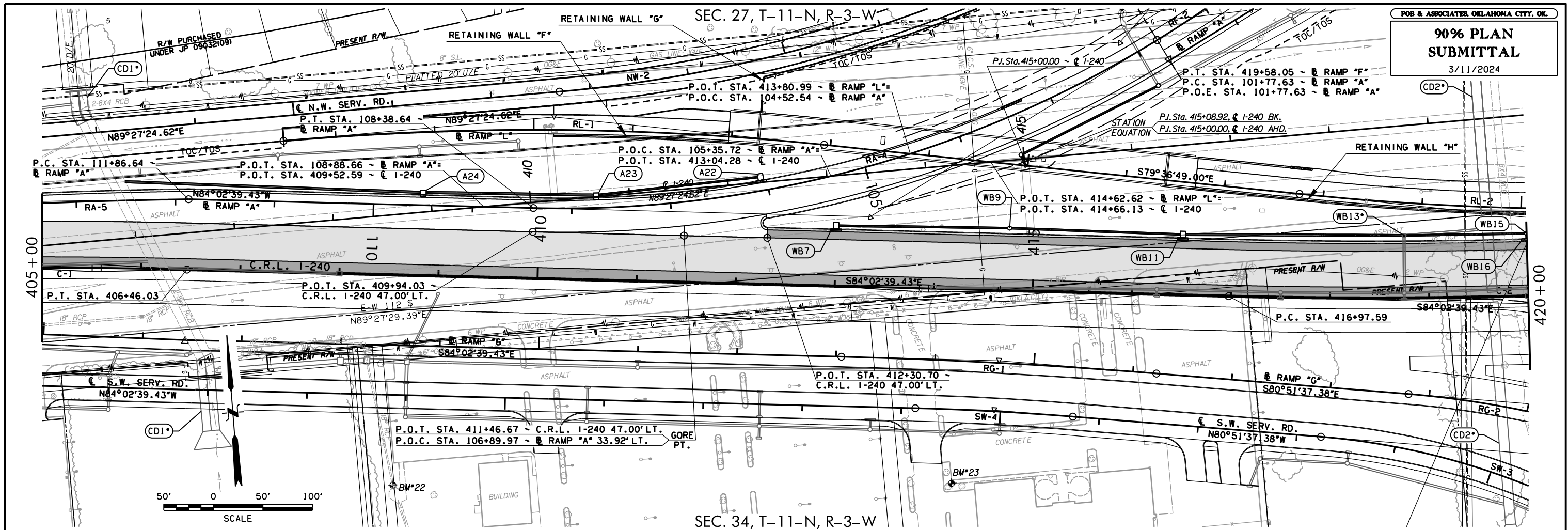

SEC. 34, T-11-N, R-3-W

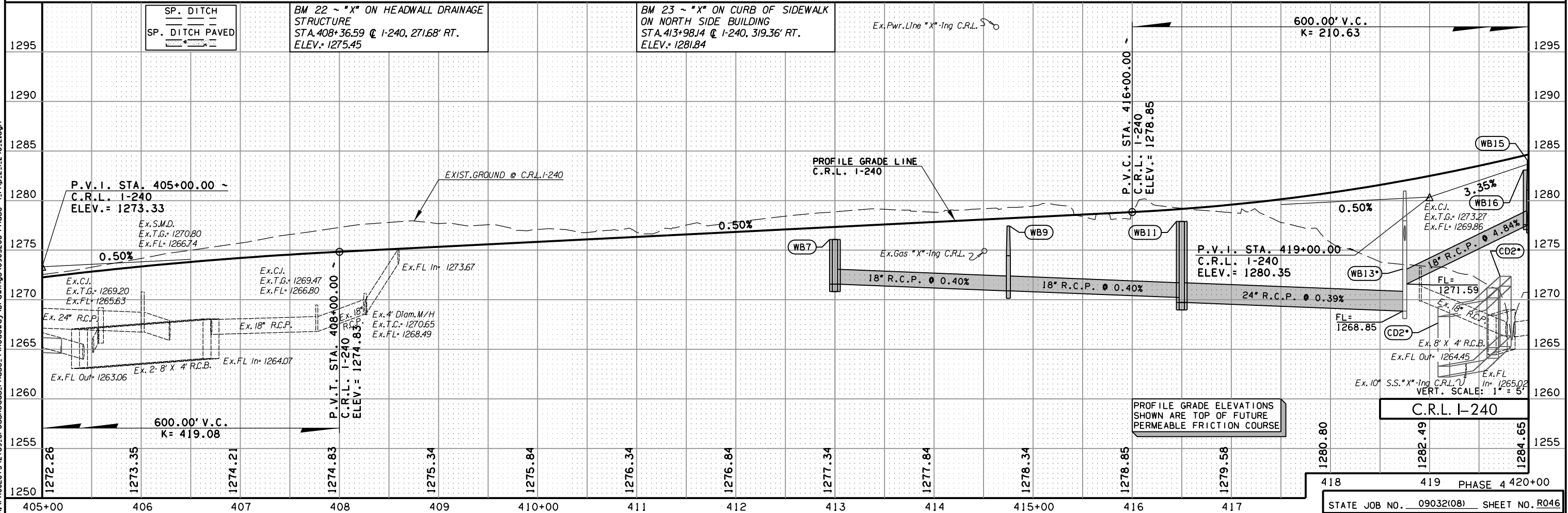

3/11/2024 7:50:02 PM H:\PROJECTS\2789_9_CrossRoads_Phase 4\Roadway\Drawings\0903208-Phase 4\Prop-2.1.240.2.dgn

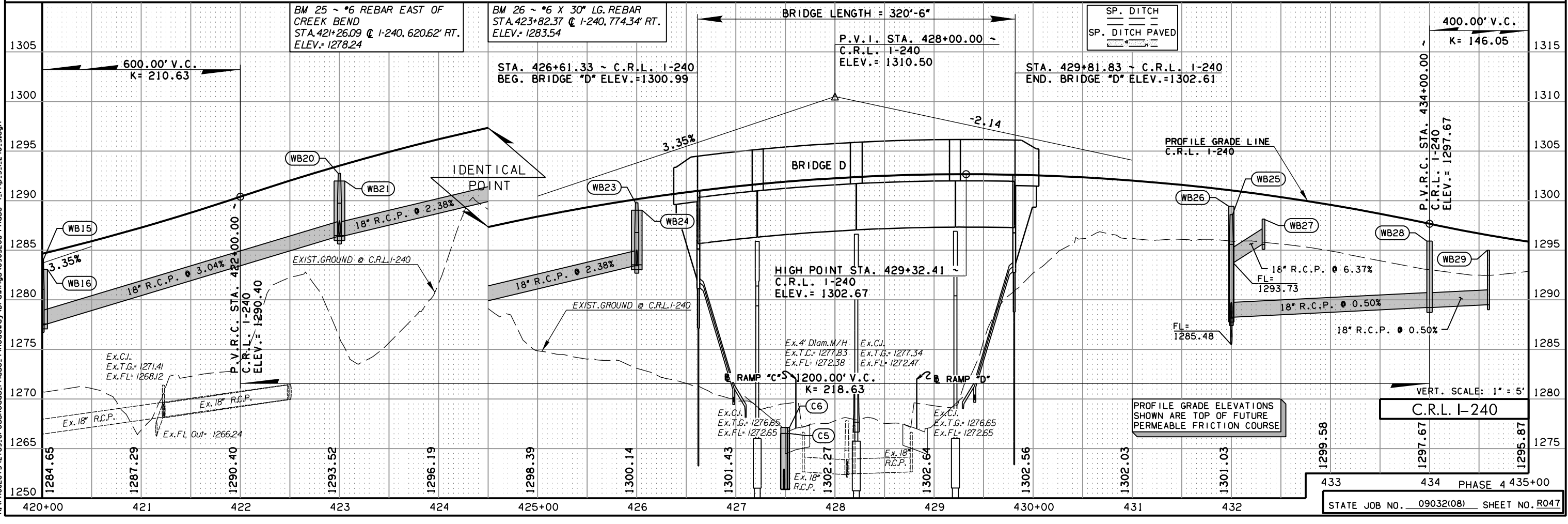
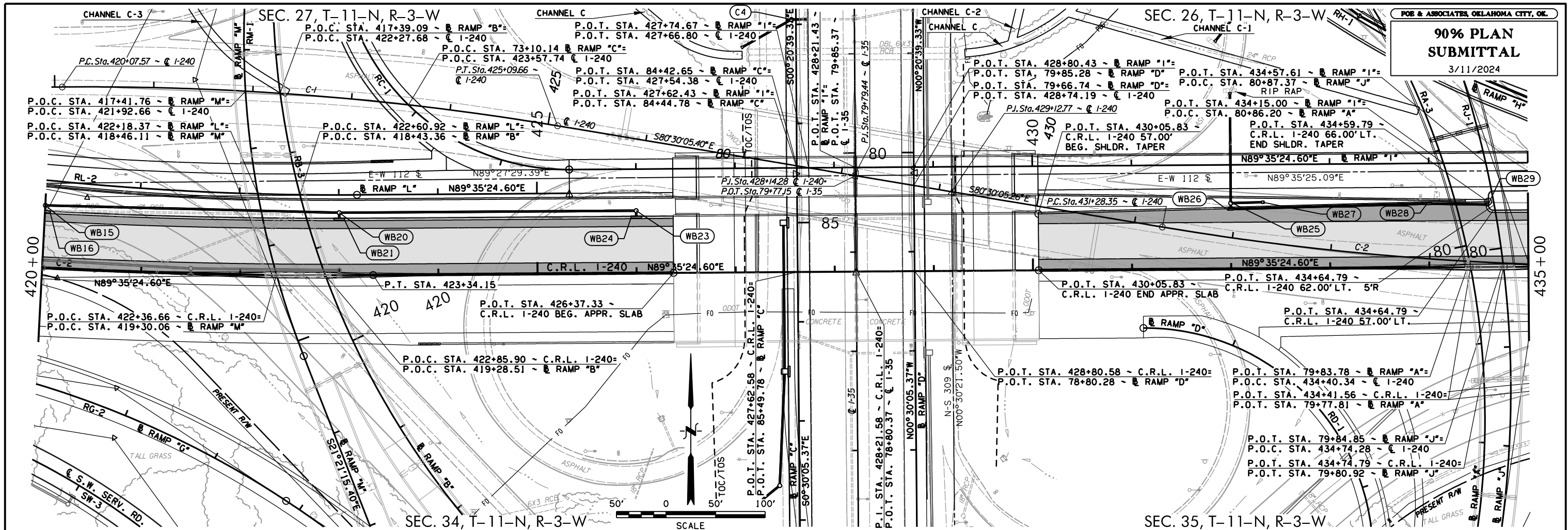

3/11/2024 7:50:06 PM
 H:\PROJECTS\2789_CrossRoads\Phase 4\Roadway\Drawings\0903208-Phase 4\Prop.3.1.240.3.dgn

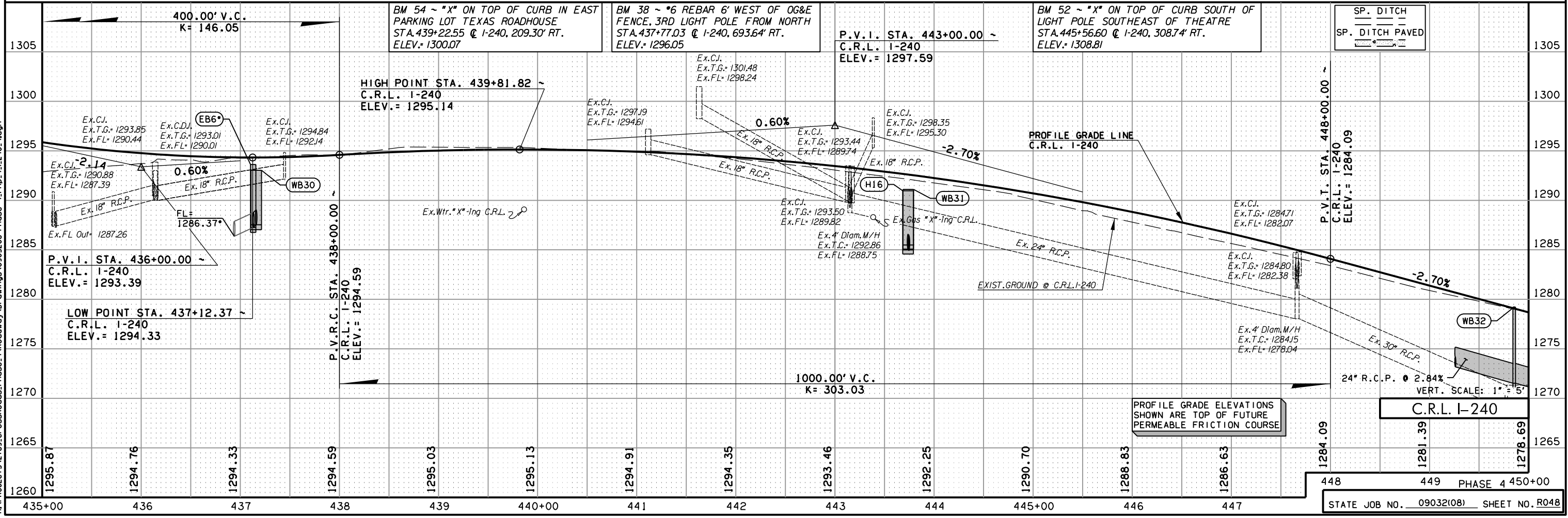
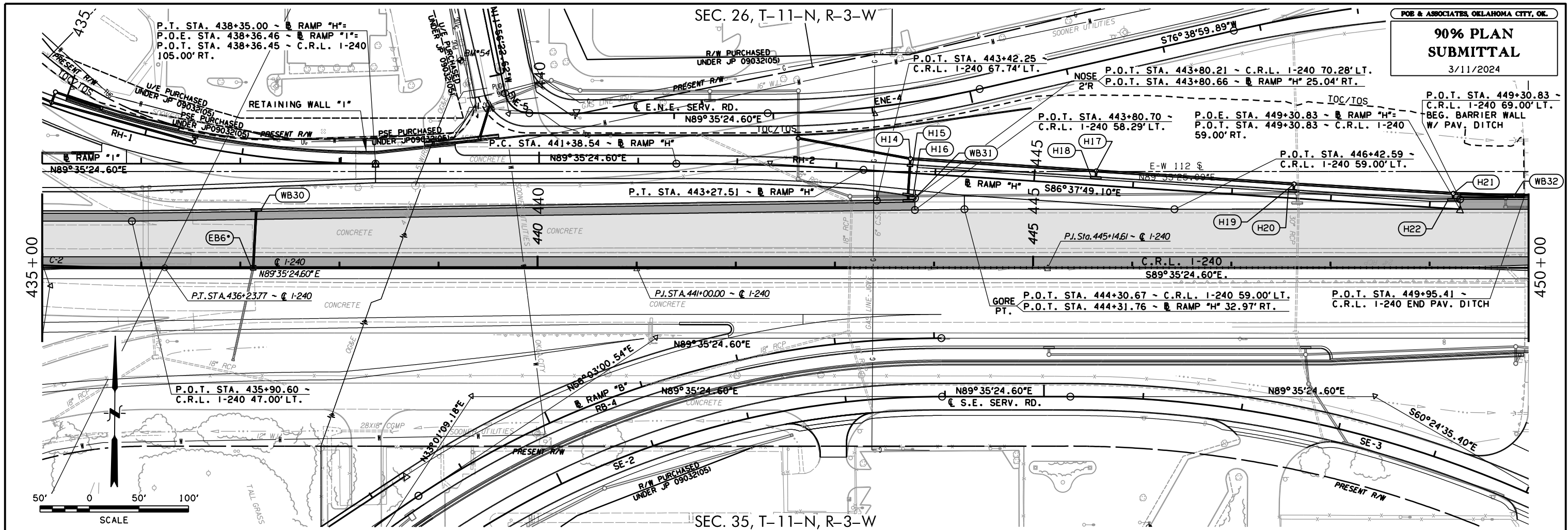

3/11/2024 7:51:00 PM
 H:\PROJECTS\2789_9_CrossRoads_Phase 4\Roadway\Drawings\0903208-Phase 4\Prop 4-1-240-4.dgn

90% PLAN SUBMITTAL

3/11/2024

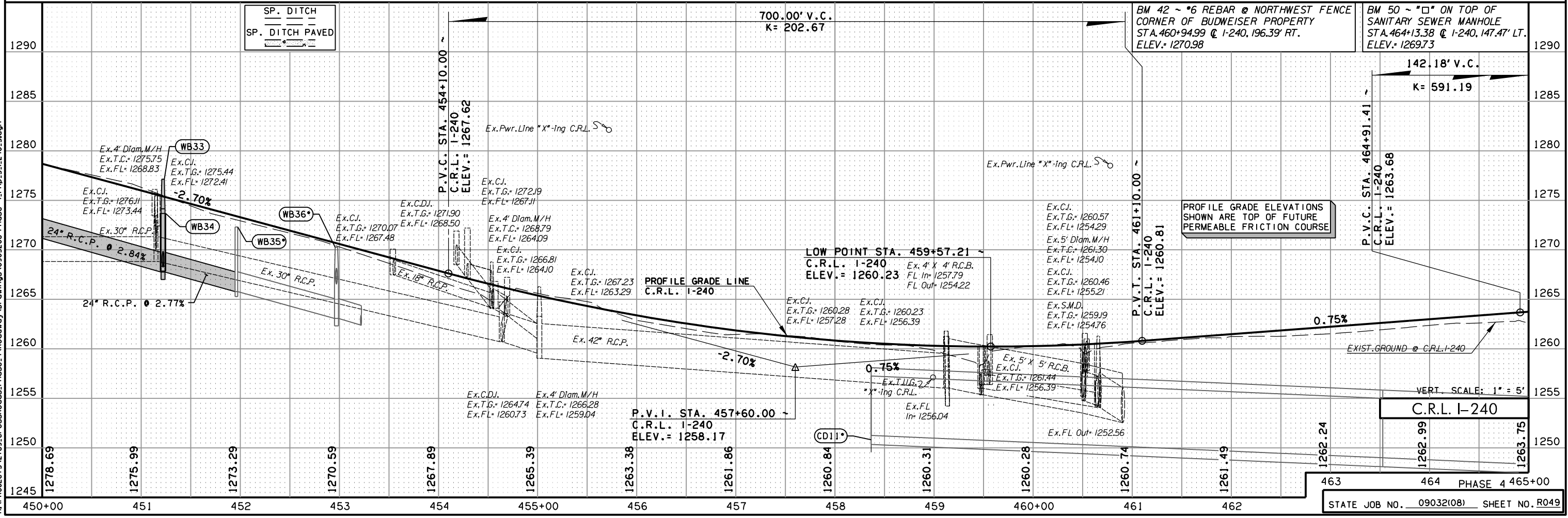
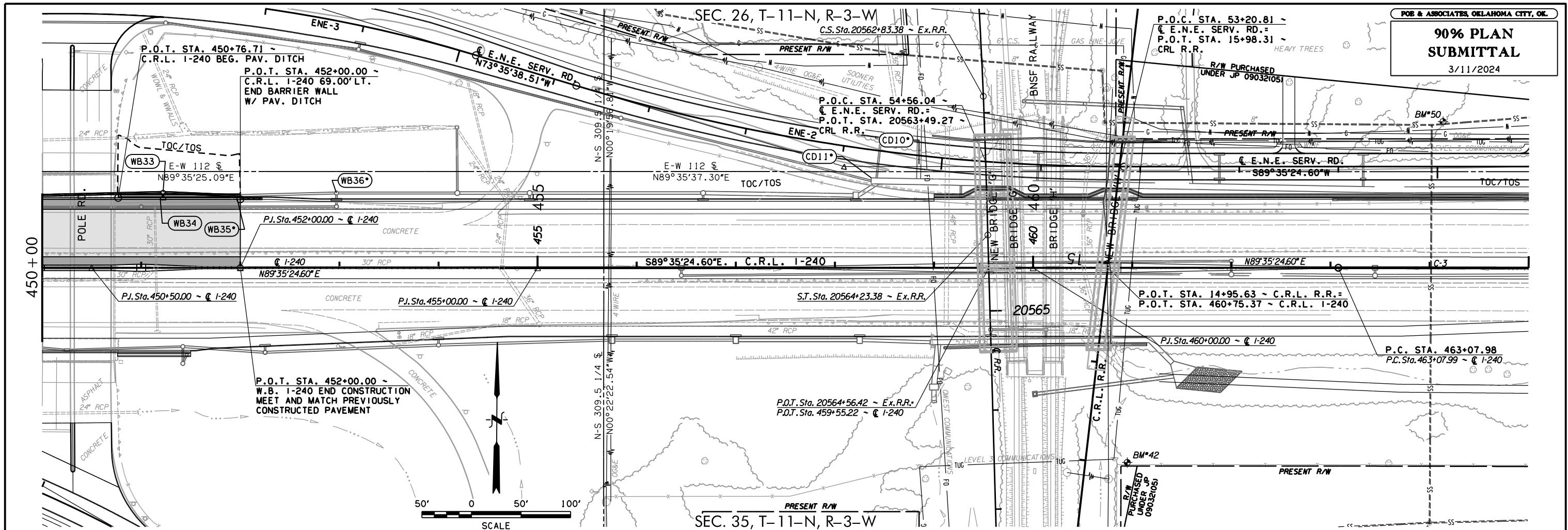

3/11/2024 7:51:33 PM H:\PROJECTS\2789_CrossRoads\Phase 4\Roadway\Drawings\0903208-Phase 4\Prop 5.1.240_5.dgn

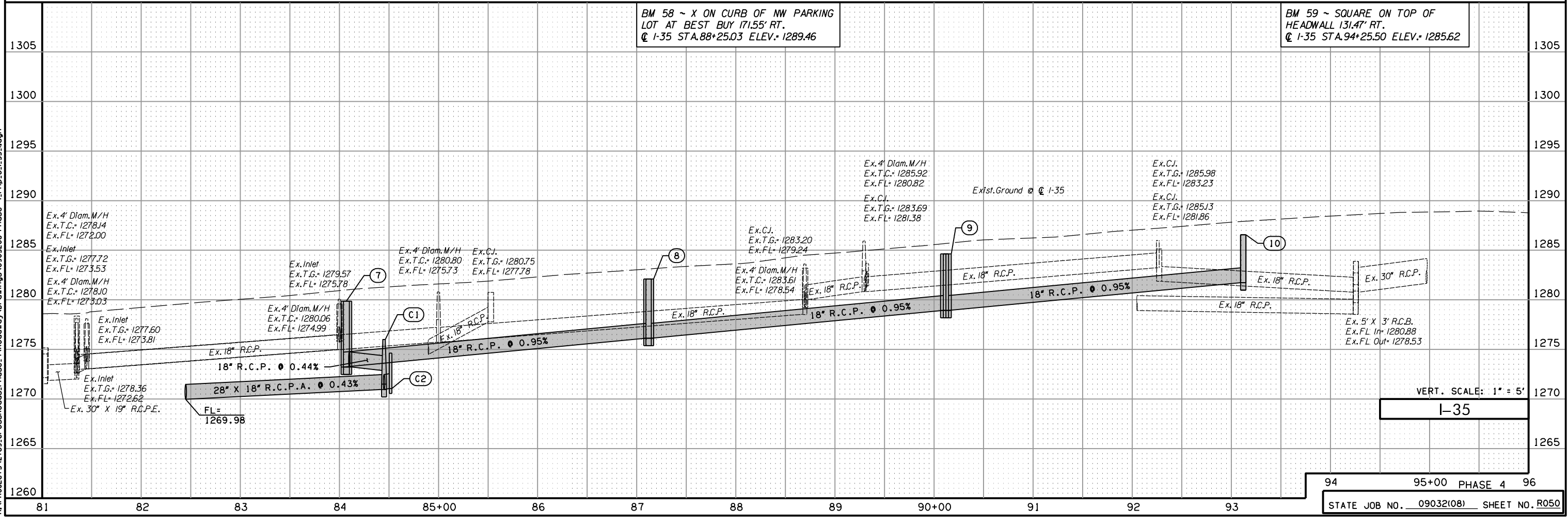
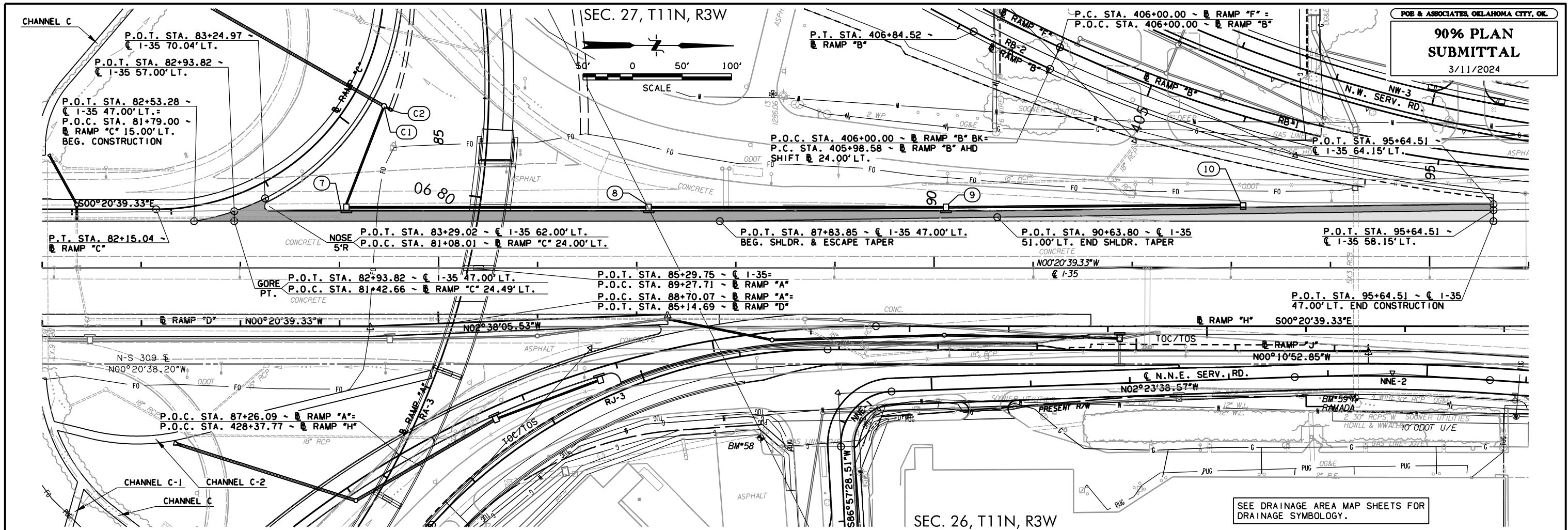

3/11/2024 7:51:17 PM
 H:\PROJECTS\2789_Crossroads\Phase 4\Roadway\Drawings\0903208-Phase 4\Prop. 6.1.35.1.dgn

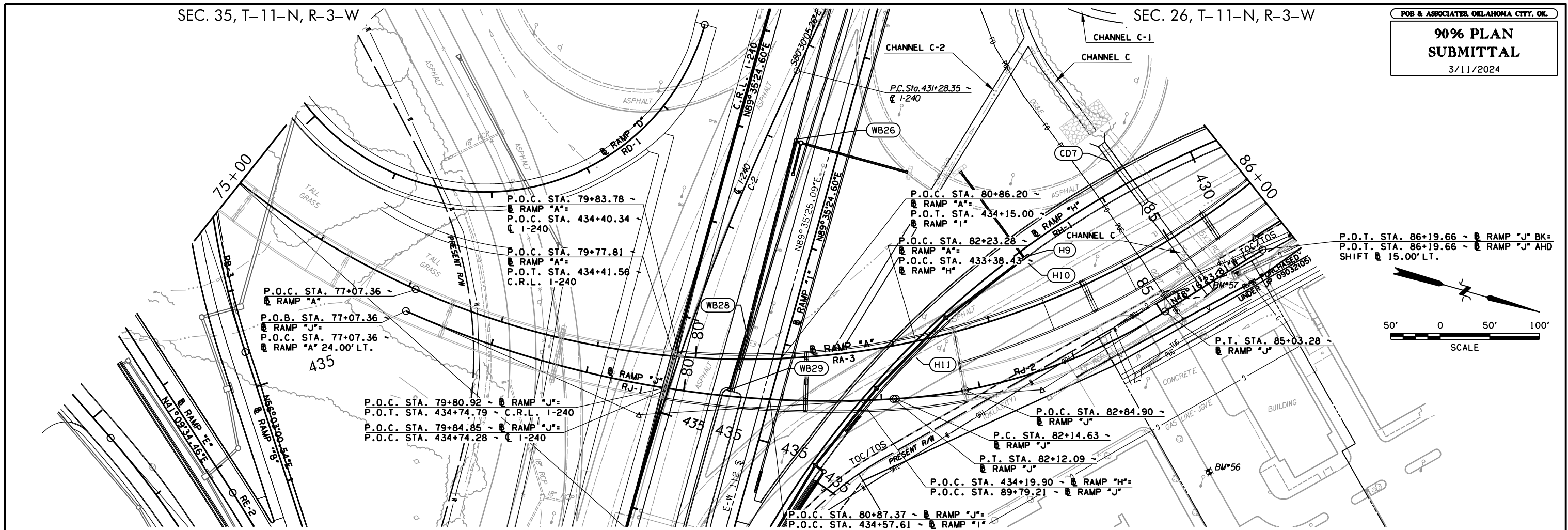

P.O.T. STA. 86+19.66 ~ RAMP "J" BK=
P.O.T. STA. 86+19.66 ~ RAMP "J" AHD
SHIFT @ 15.00' LT.

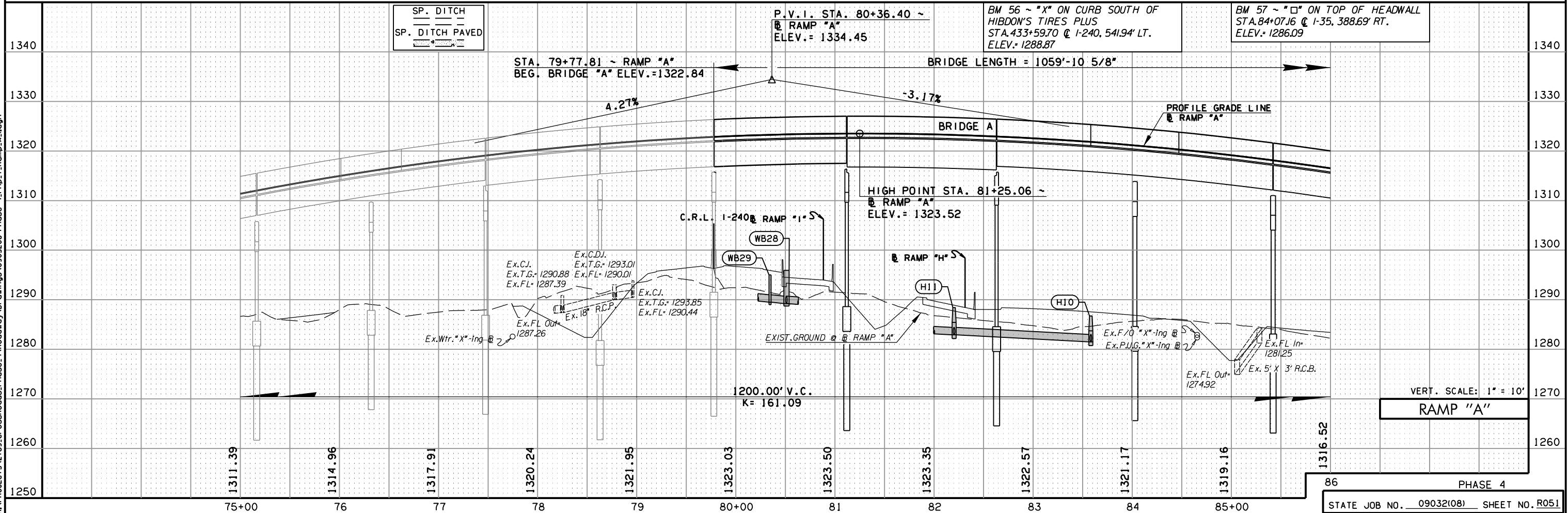
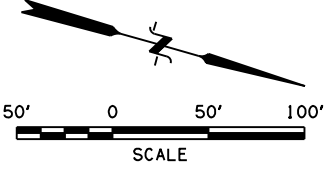

VERT. SCALE: 1" = 10'
RAMP "A"

3/11/2024 7:52:23 PM H:\PROJECTS\2789_CrossRoads_Phase 4\Roadway\Drawings\0903208-Phase 4\Prop. 7.Ramp_A.Ldgn

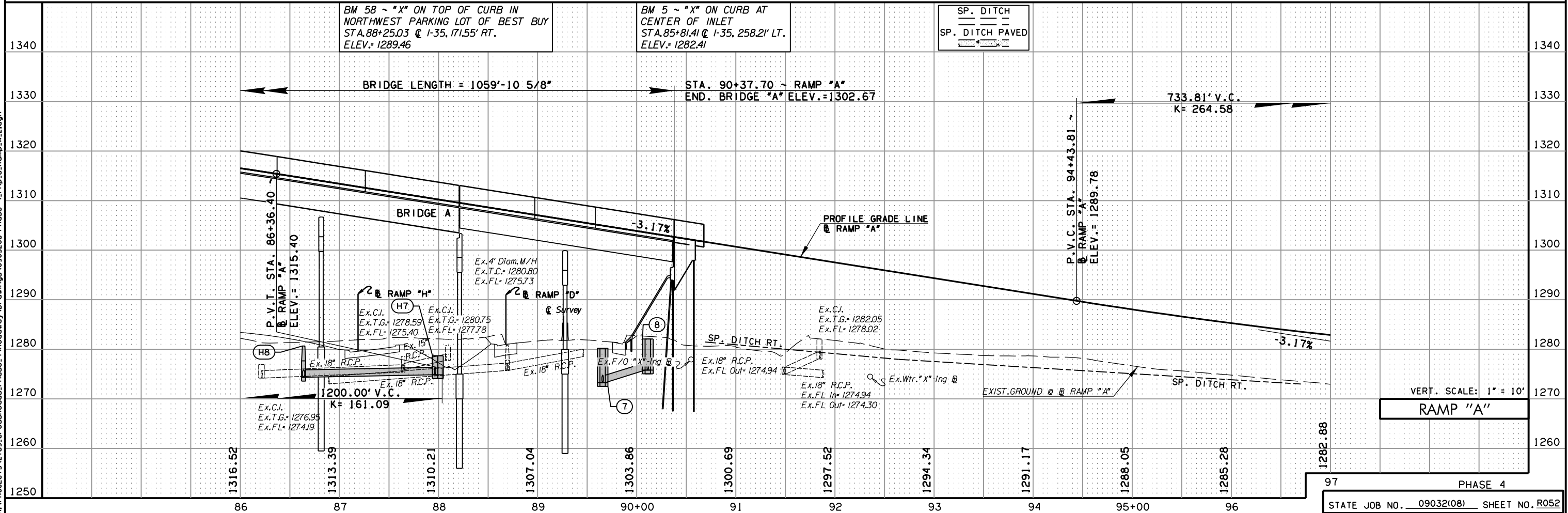
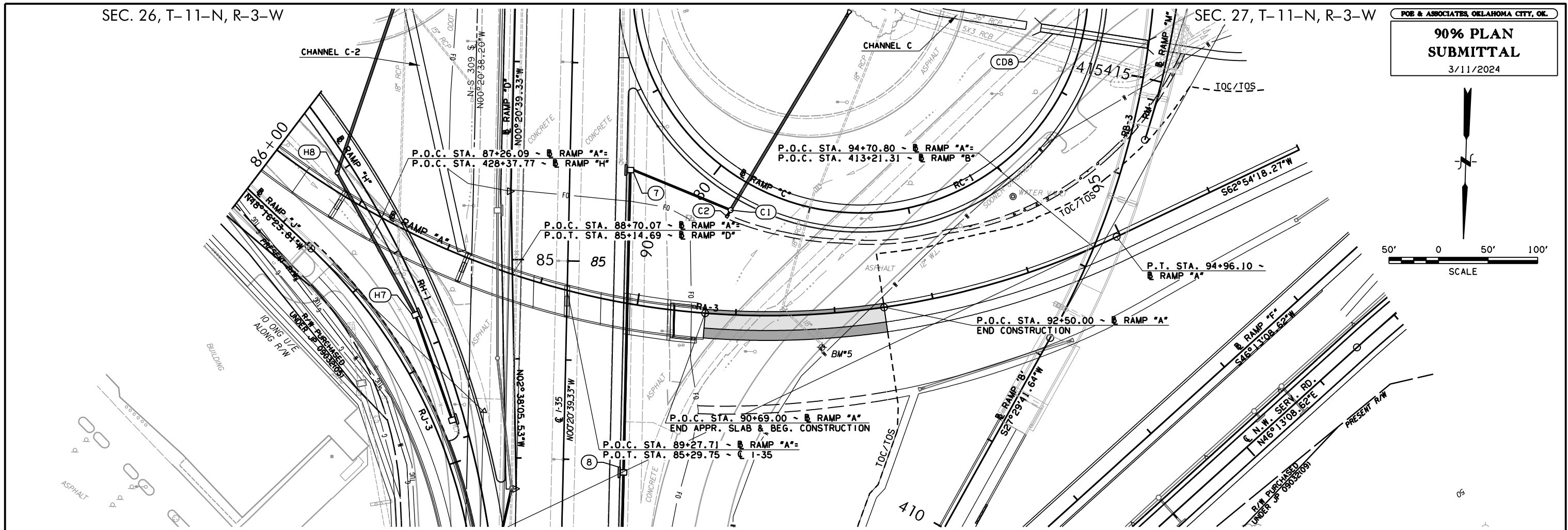
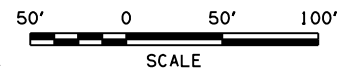

3/11/2024 7:52:27 PM
H:\PROJECTS\2789_CrossRoads_Phase 4\Roadway\Drawings\0903208-Phase 4\Prop. 8.Ramp_A.2.dgn

VERT. SCALE: 1" = 10'

RAMP "A"

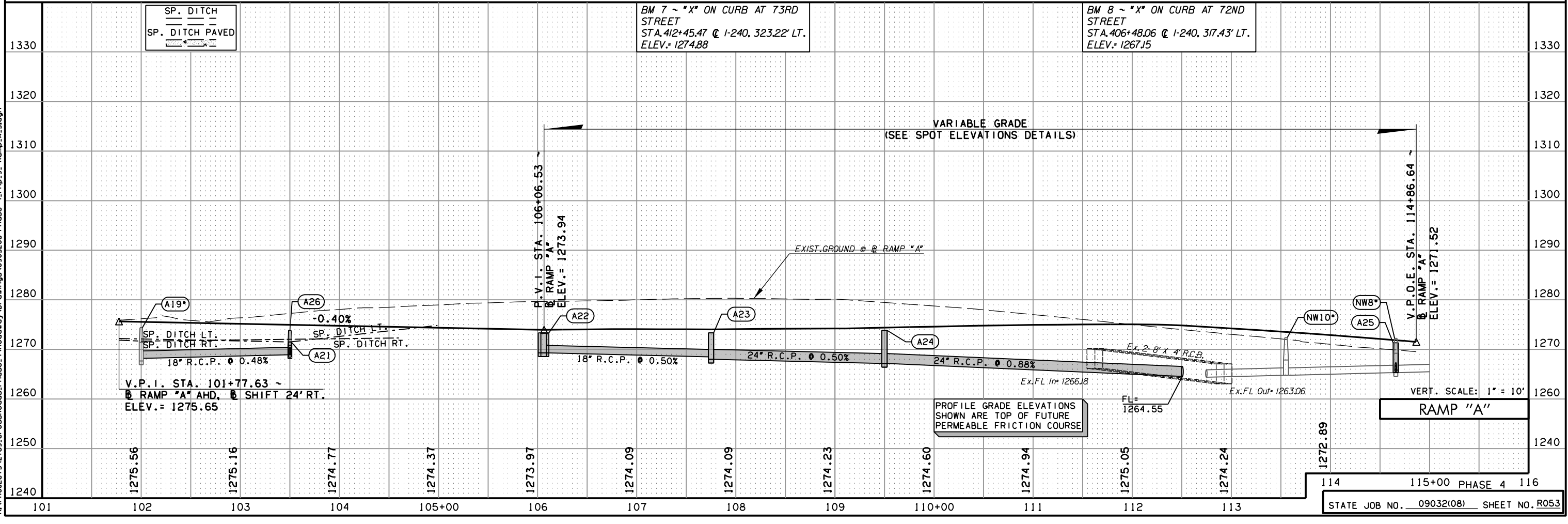
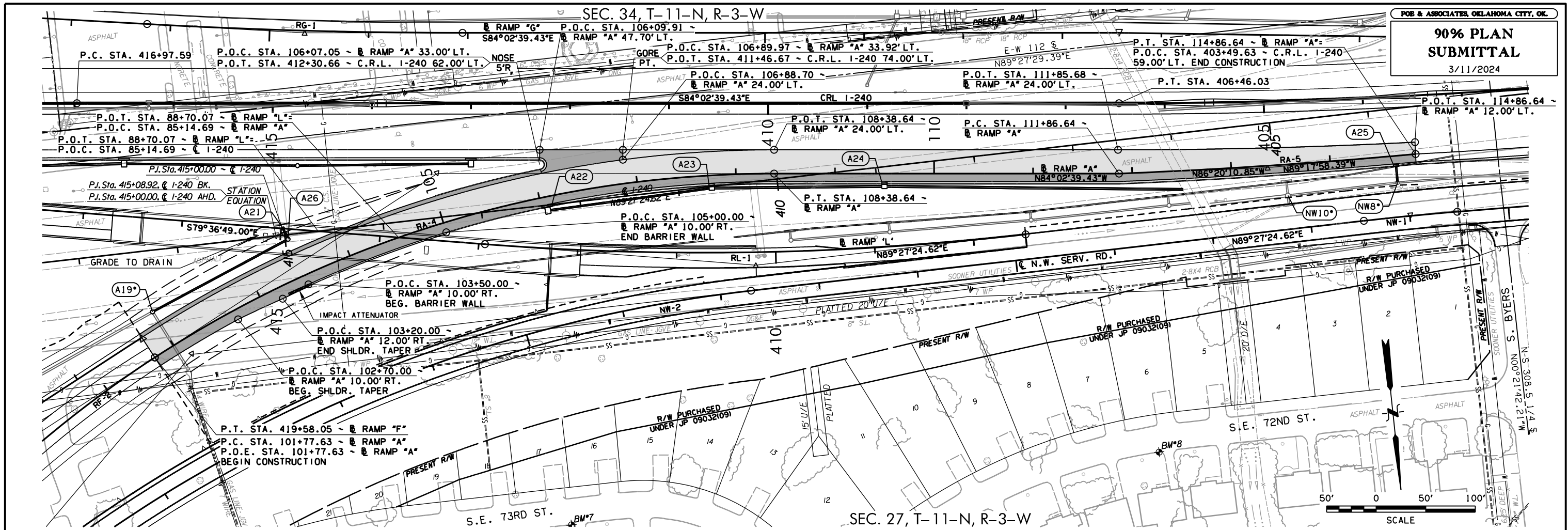

3/11/2024 7:51:33 PM H:\PROJECTS\2789_CrossRoads_Phase 4\Roadway\Drawings\0903208-Phase 4_Prop.9_Ramp.A.3.dgn

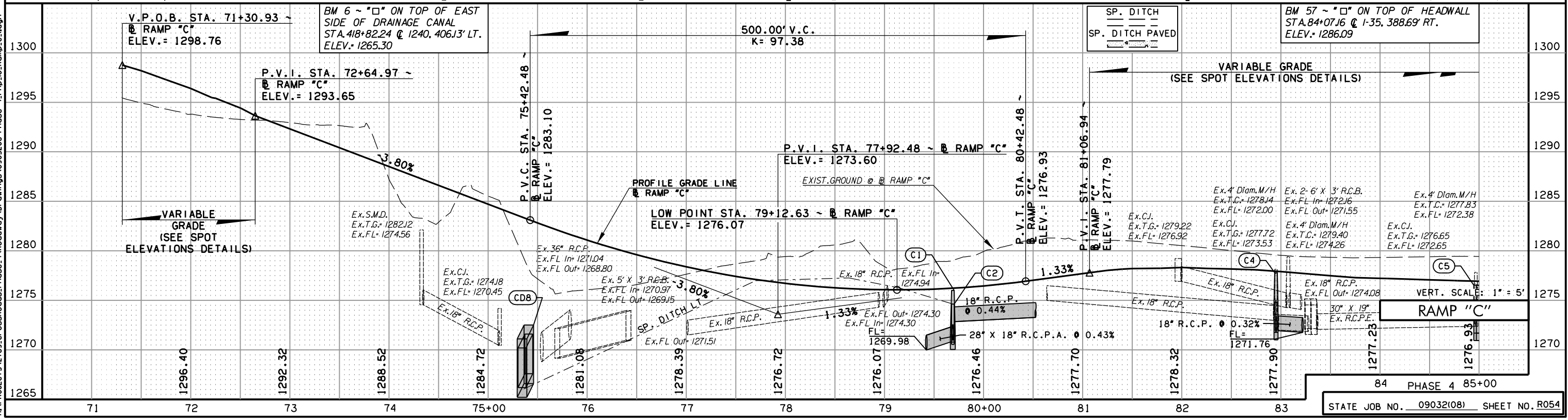
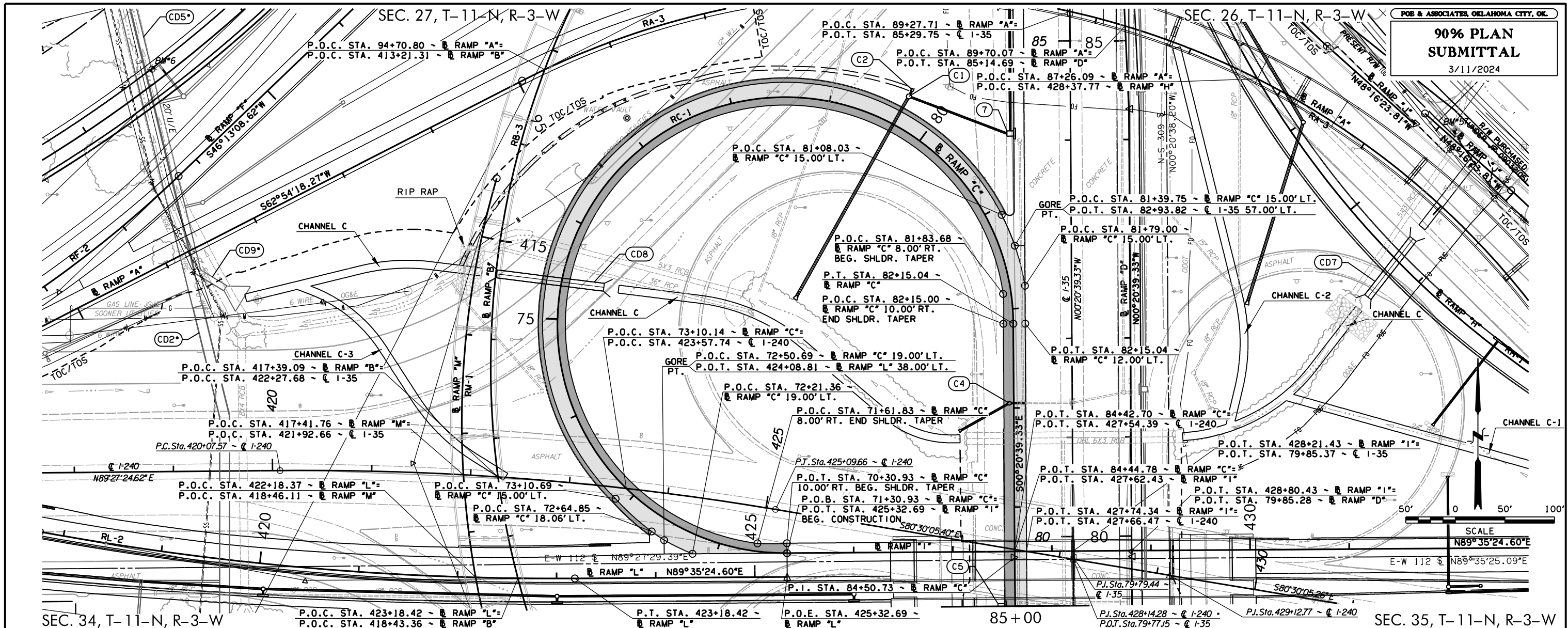

3/11/2024 7:51:36 PM
 H:\PROJECTS\2789_CrossRoads_Phase 4\Roadway\Drawings\0903208-Phase 4_Prop_IO_Ramp_C.dgn

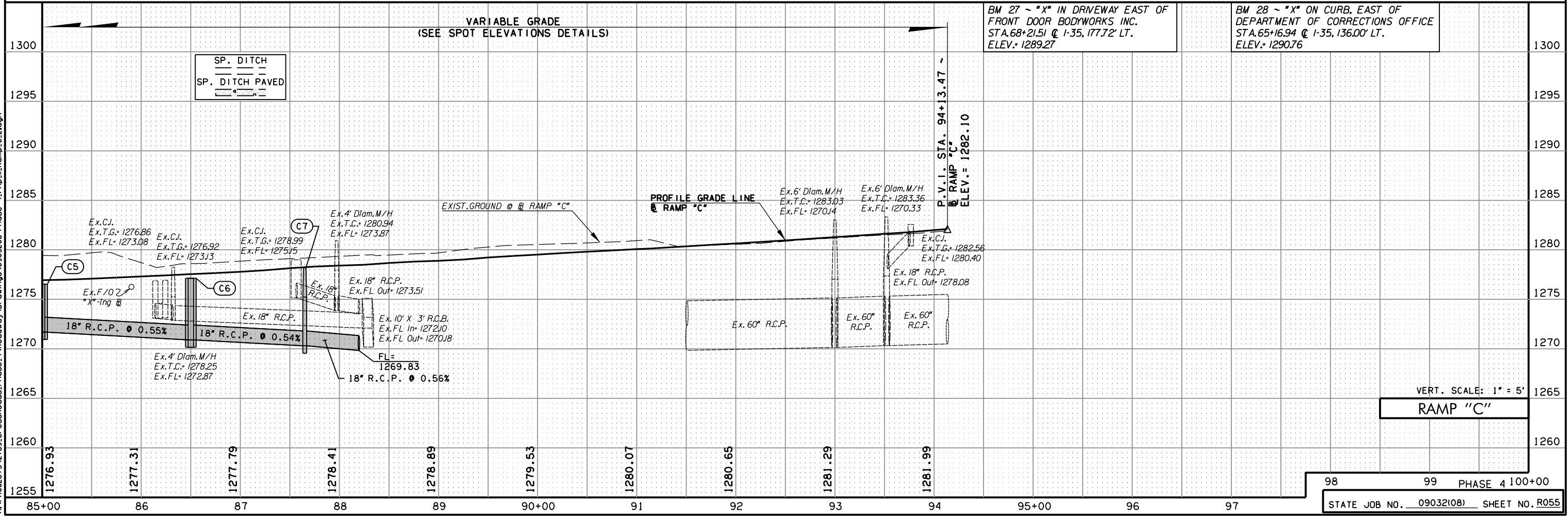
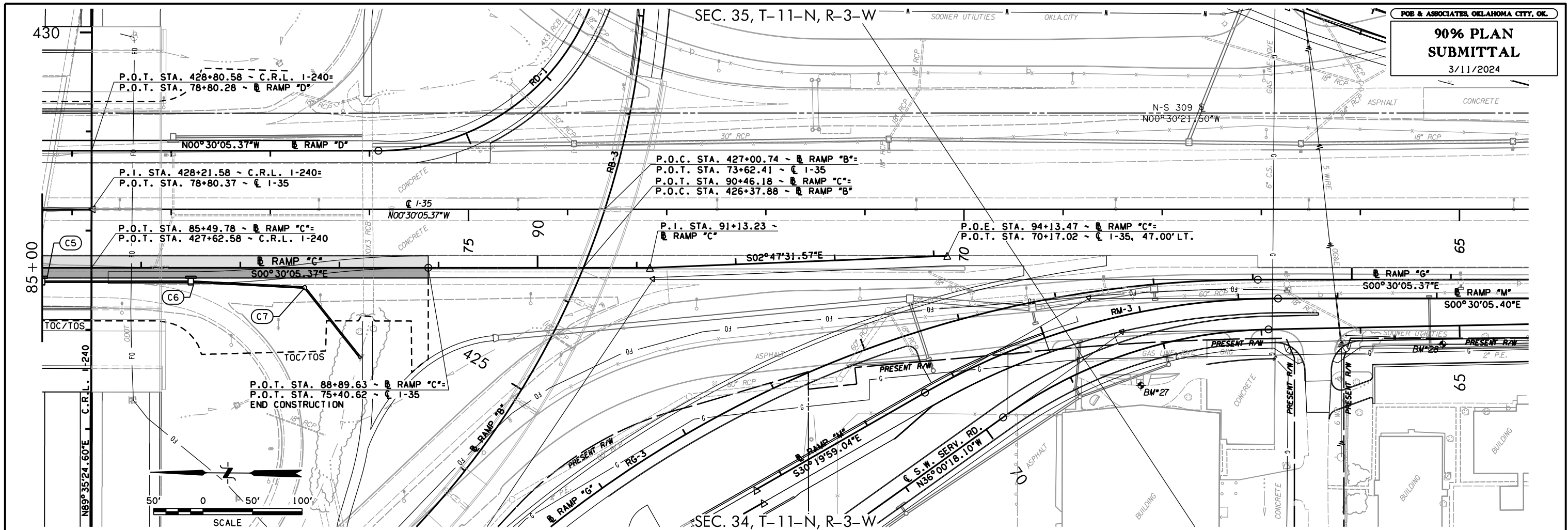

3/11/2024 7:54:41 PM
 H:\PROJECTS\2789_CrossRoads_Phase 4\Roadway\Drawings\0903208-Phase 4_Prop. II_Ramp_C.dgn

SEC. 27, T-11-N, R-3-W

POB & ASSOCIATES, OKLAHOMA CITY, OK.

90% PLAN
SUBMITTAL

3/11/2024

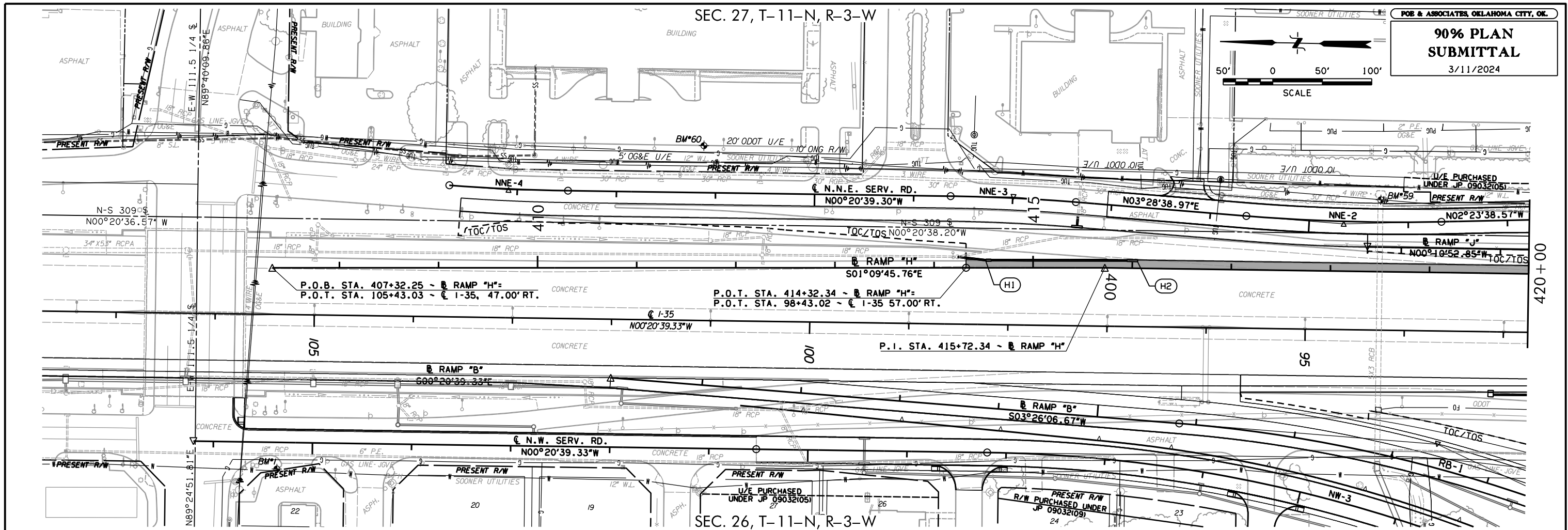
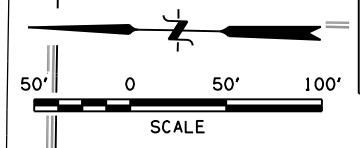

SEC. 26, T-11-N, R-3-W

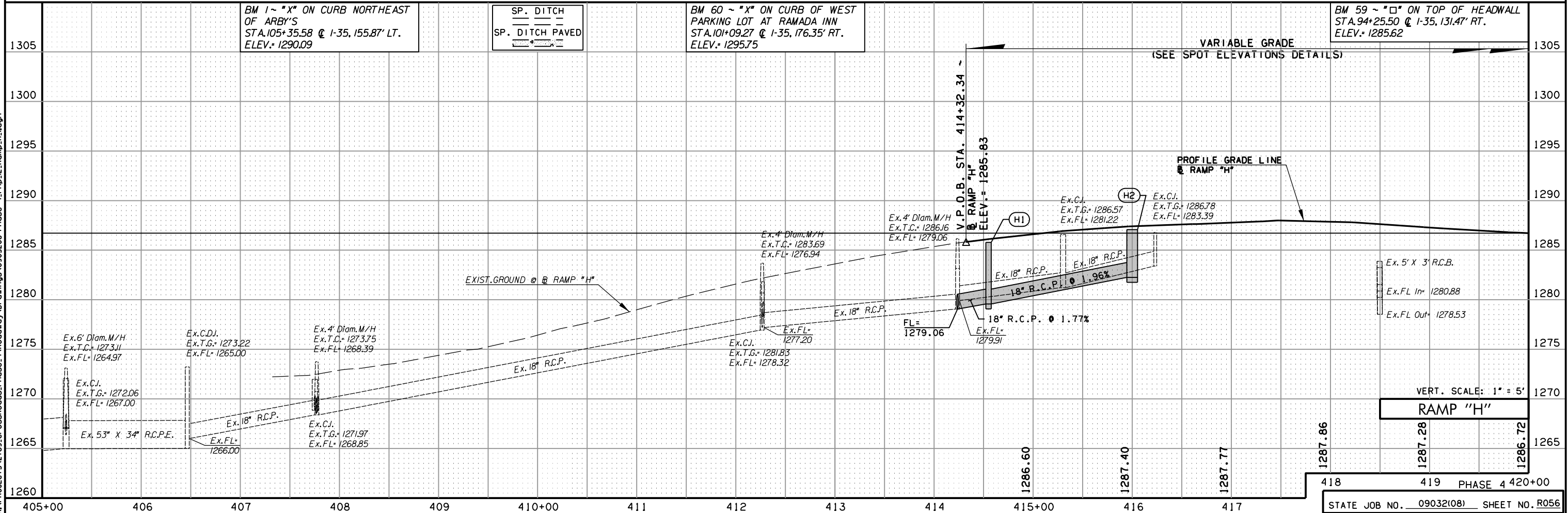

BM 1 ~ "X" ON CURB NORTHEAST OF ARBY'S
STA. 105+35.58 @ I-35, 155.87' LT.
ELEV.: 1290.09

SP. DITCH
SP. DITCH PAVED

BM 60 ~ "X" ON CURB OF WEST PARKING LOT AT RAMADA INN
STA. 101+09.27 @ I-35, 176.35' RT.
ELEV.: 1295.75

BM 59 ~ "□" ON TOP OF HEADWALL
STA. 94+25.50 @ I-35, 131.47' RT.
ELEV.: 1285.62

VARIABLE GRADE
(SEE SPOT ELEVATIONS DETAILS)

PROFILE GRADE LINE
RAMP "H"

VERT. SCALE: 1" = 5'

RAMP "H"

418 419 PHASE 4 420+00

STATE JOB NO. 09032(08) SHEET NO. R056

3/11/2024 7:54:42 PM H:\PROJECTS\2789_CrossRoads_Phase 4\Roadway\Drawings\0903208-Phase 4_Prop.12_Ramp_H.Ldgn

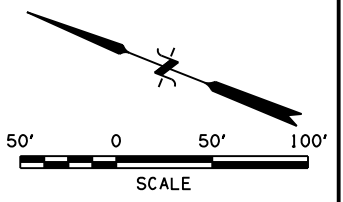

SEC. 27, T-11-N, R-3-W

SEC. 26, T-11-N, R-3-W

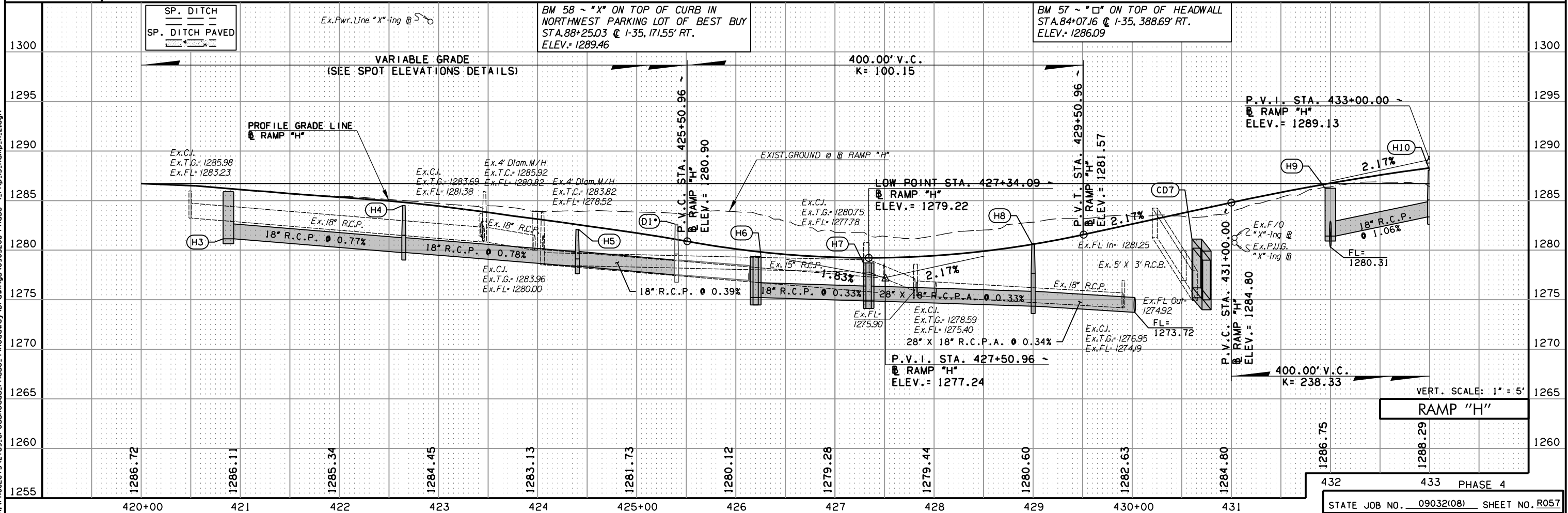
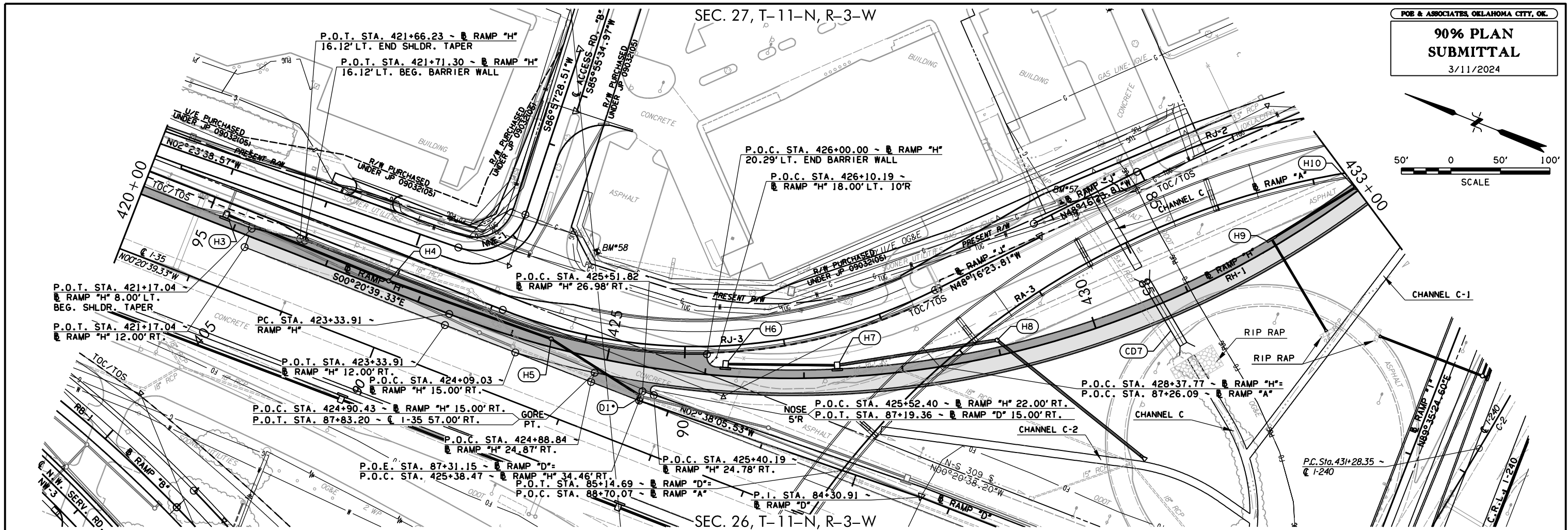

3/11/2024 7:55:52 PM
H:\PROJECTS\2789_CrossRoads_Phase 4\Roadway\Drawings\0903208-Phase 4\Prop.13_Ramp.H.2.dgn

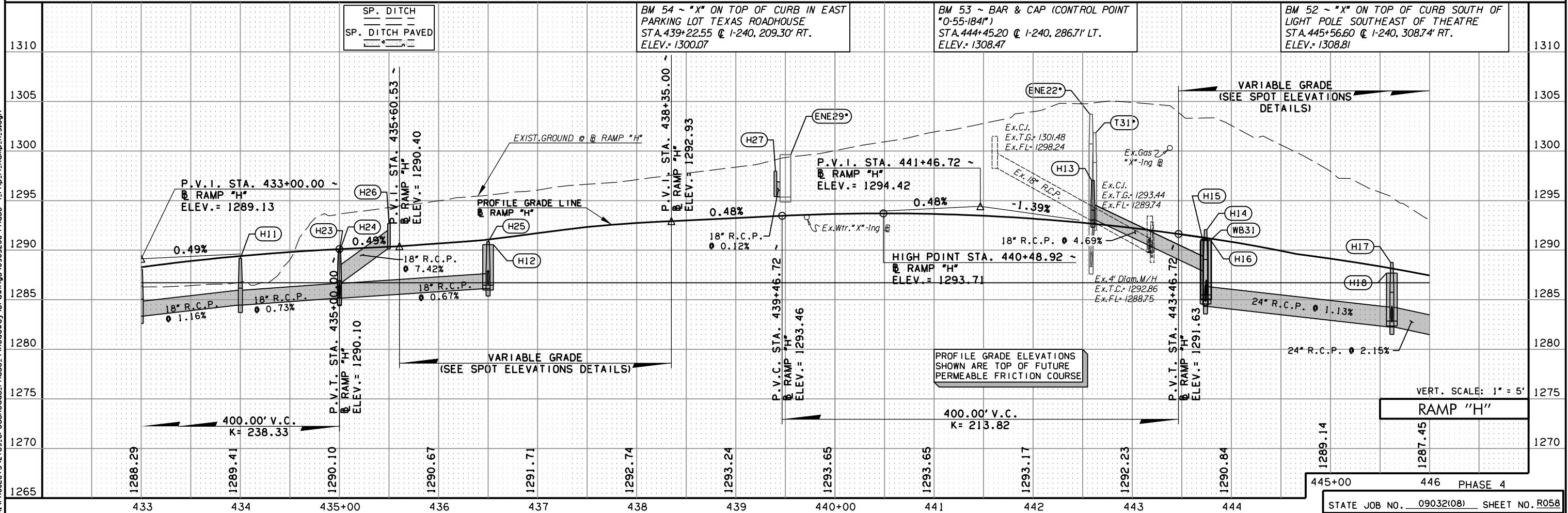
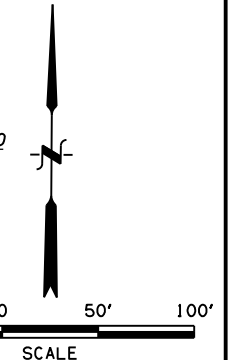
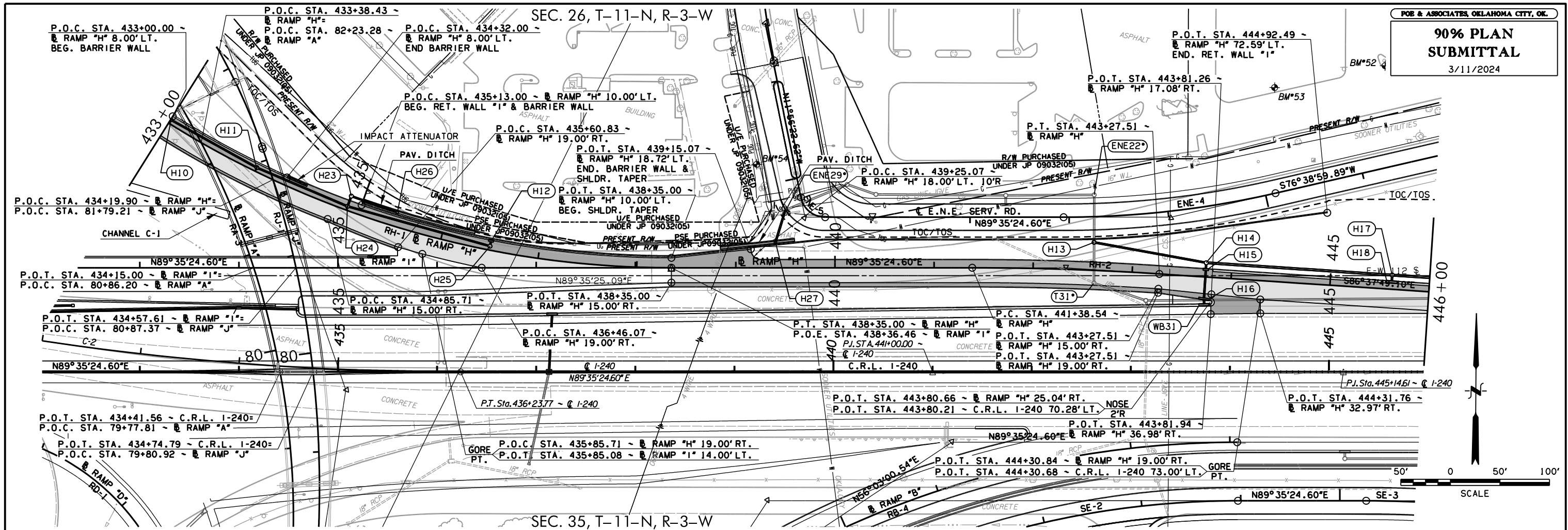

3/11/2024 7:55:57 PM
 H:\PROJECTS\2789_CrossRoads_Phase 4\Roadway\Drawings\0903208-Phase 4\Prop 14_Ramp_H_3.dgn

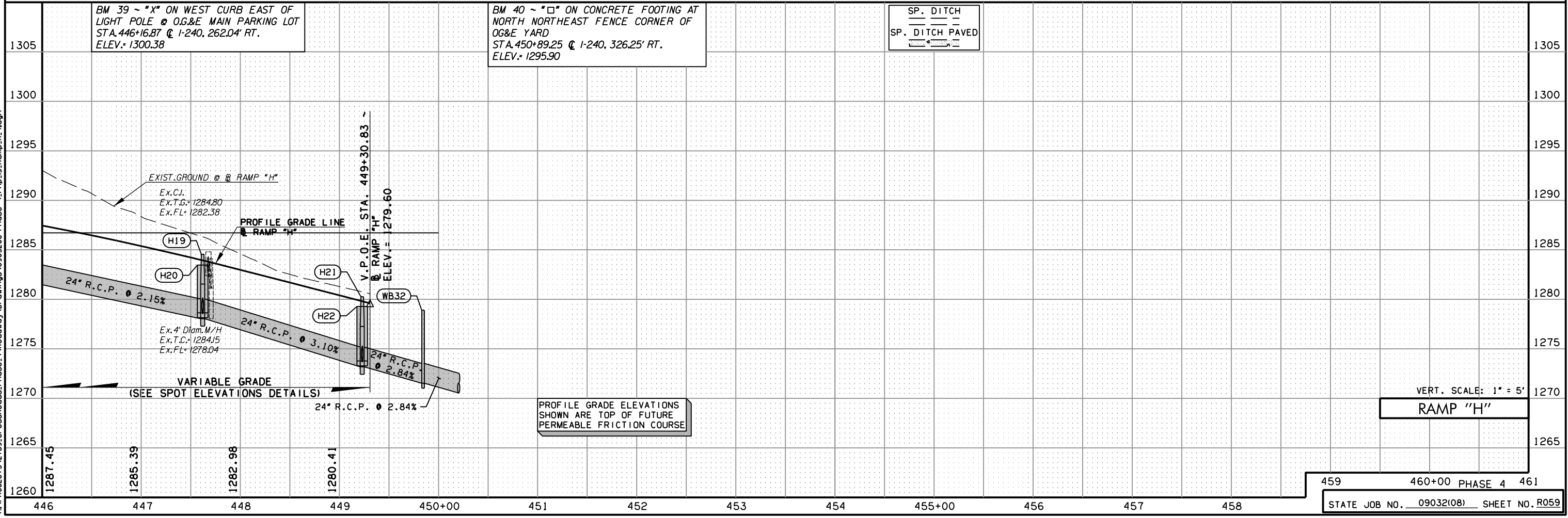
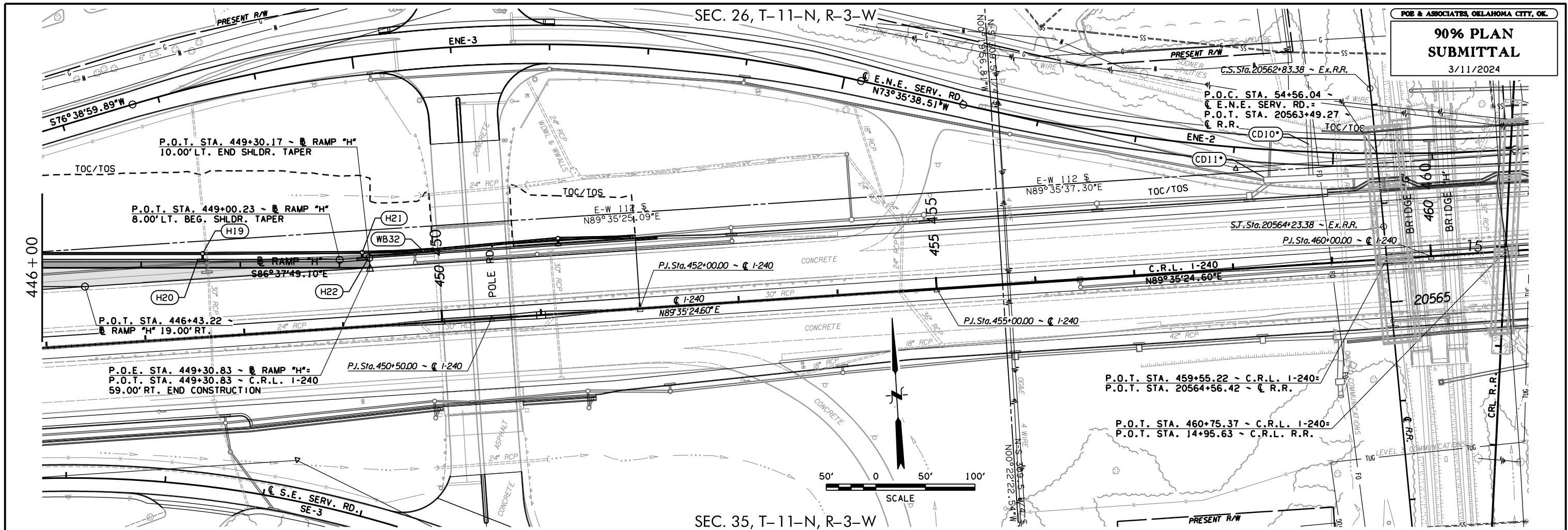

3/11/2024 7:16:02 PM H:\PROJECTS\2789_CrossRoads_Phase 4\Roadway\Drawings\0903208-Phase 4\Prop\IS_Ramp_H_4.dgn

90% PLAN SUBMITTAL

3/11/2024

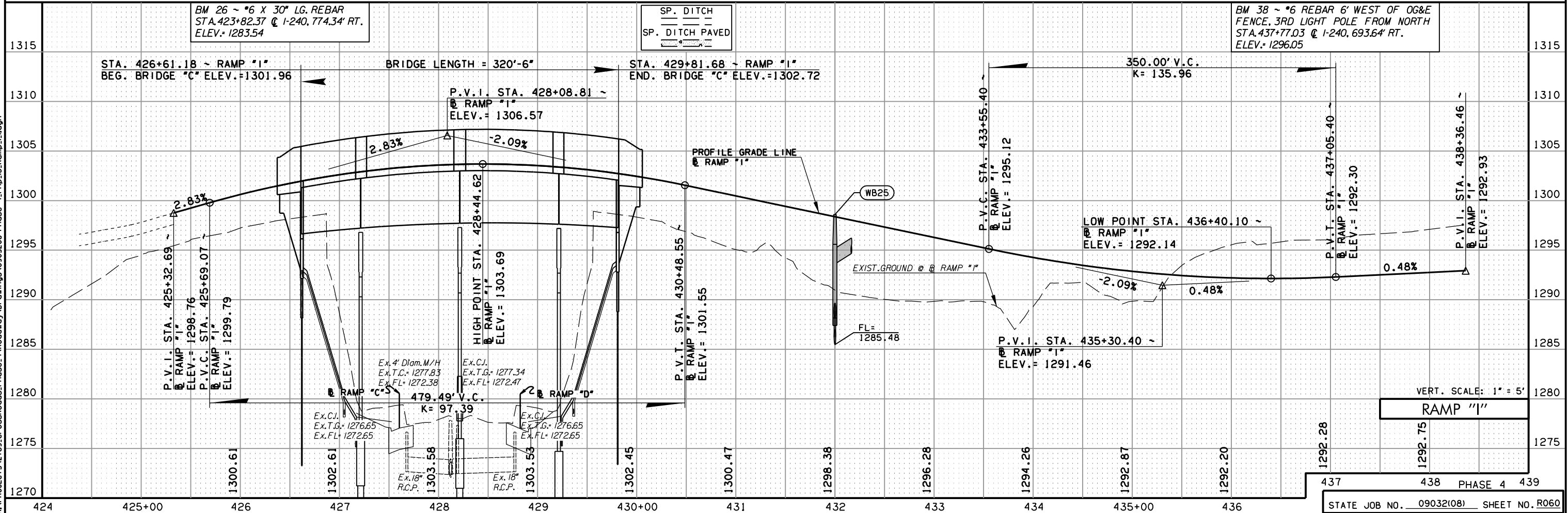
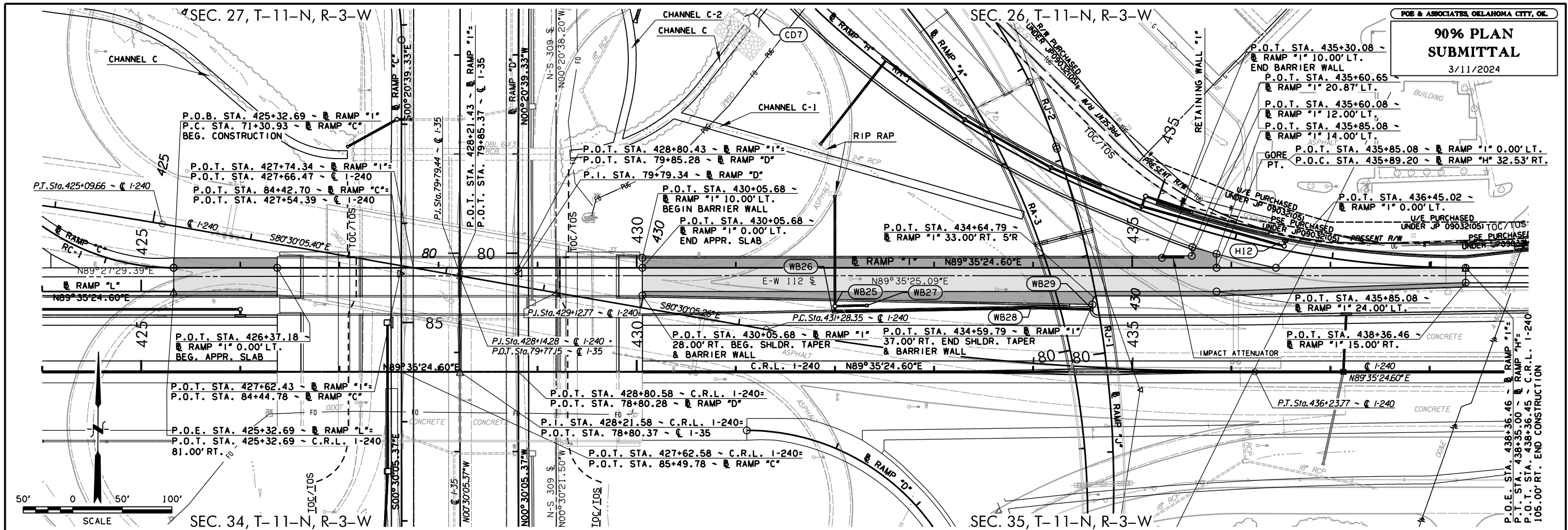

3/11/2024 1:41:11 PM H:\PROJECTS\2789_CrossRoads_Phase 4\Roadway\Drawings\0903208-Phase 4\Prop.16_Ramp_1.Ldgn

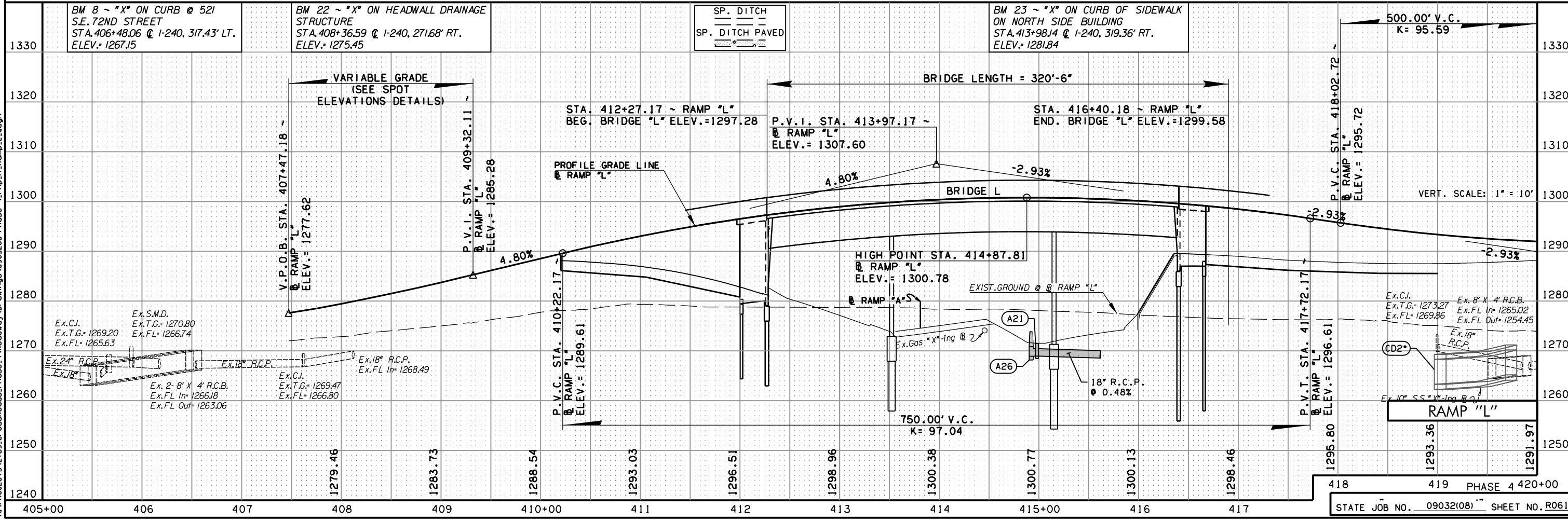
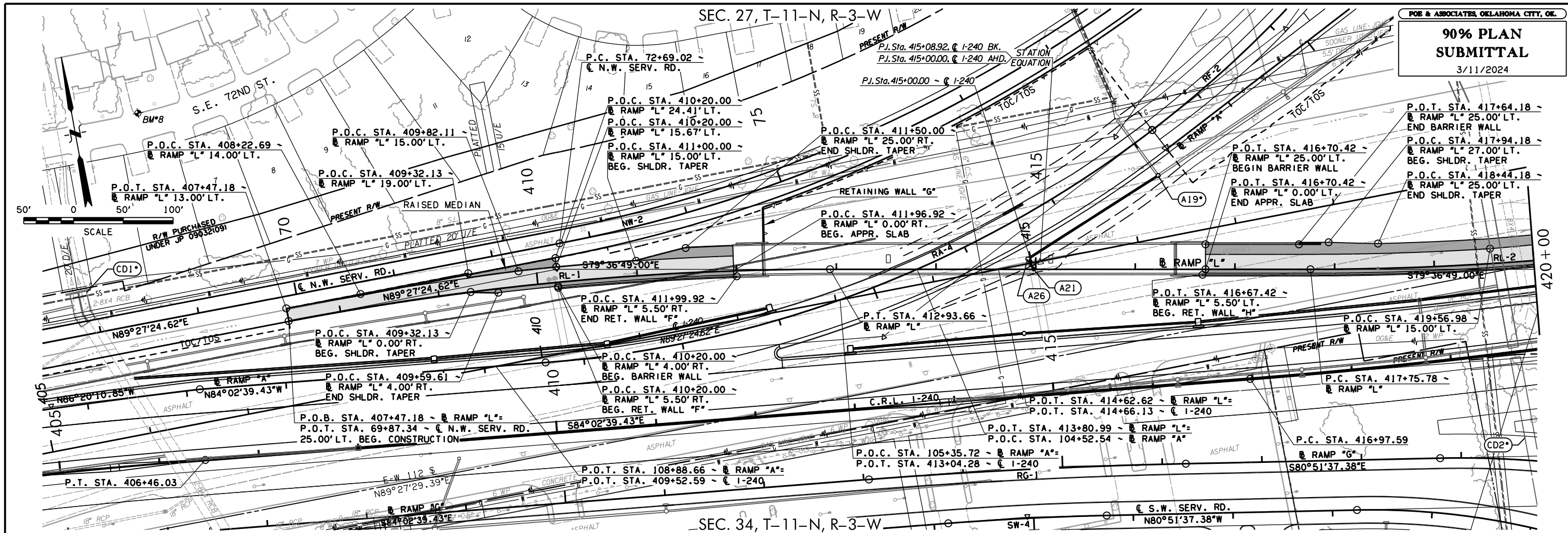

3/11/2024 11:16:19 PM H:\PROJECTS\2789_9_CrossRoads\Phase 4\Roadway\Drawings\0903208-Phase 4 Prop.IT_Ramp.L.dgn

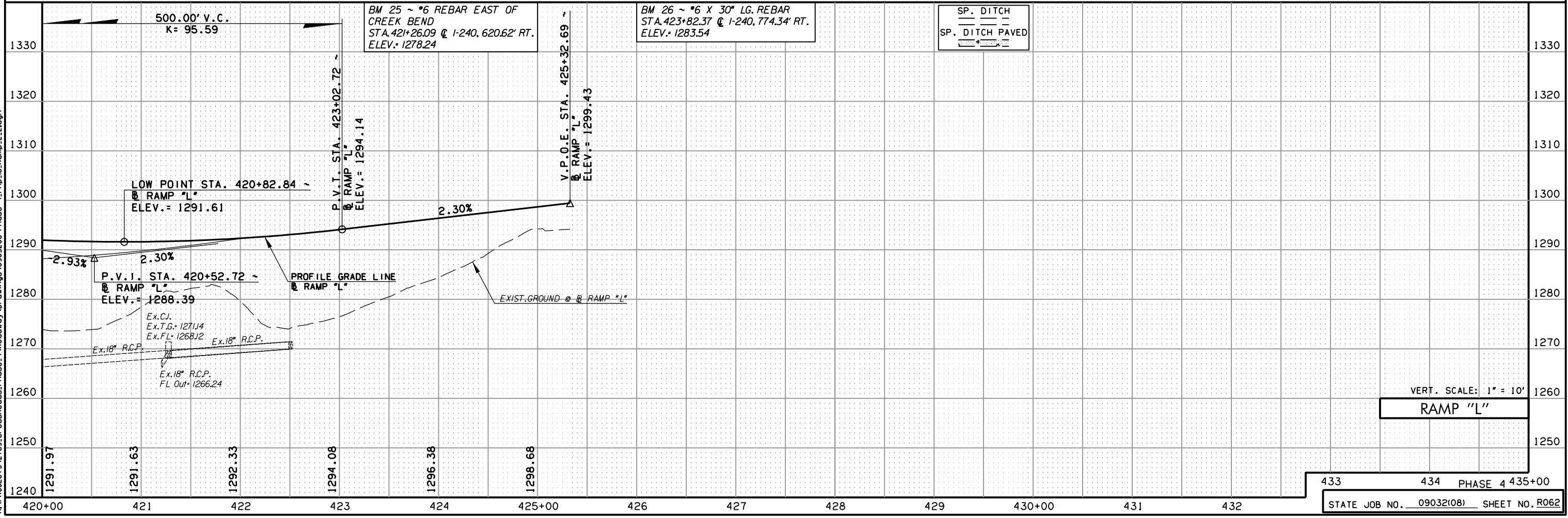
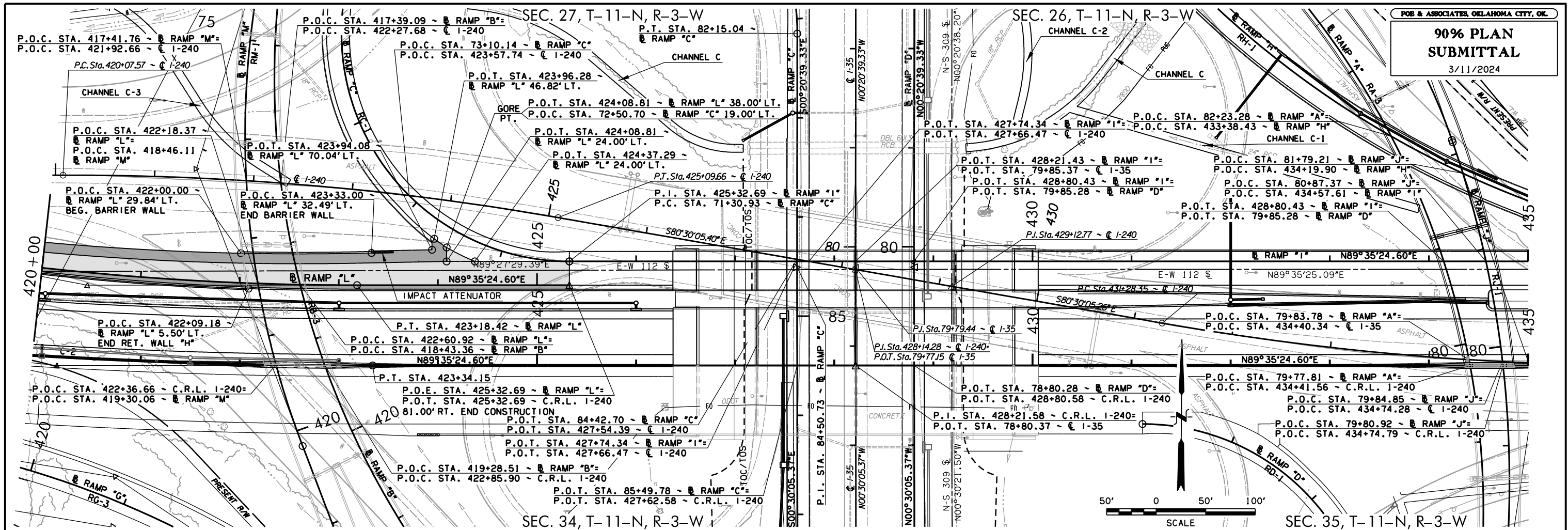

3/11/2024 7:16:24 PM H:\PROJECTS\2789_CrossRoads_Phase 4\Roadway\Drawings\0903208-Phase 4_Prop_IB_Ramp_L-2.dgn

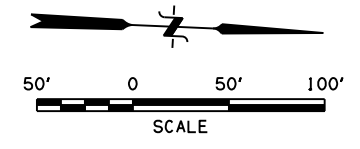
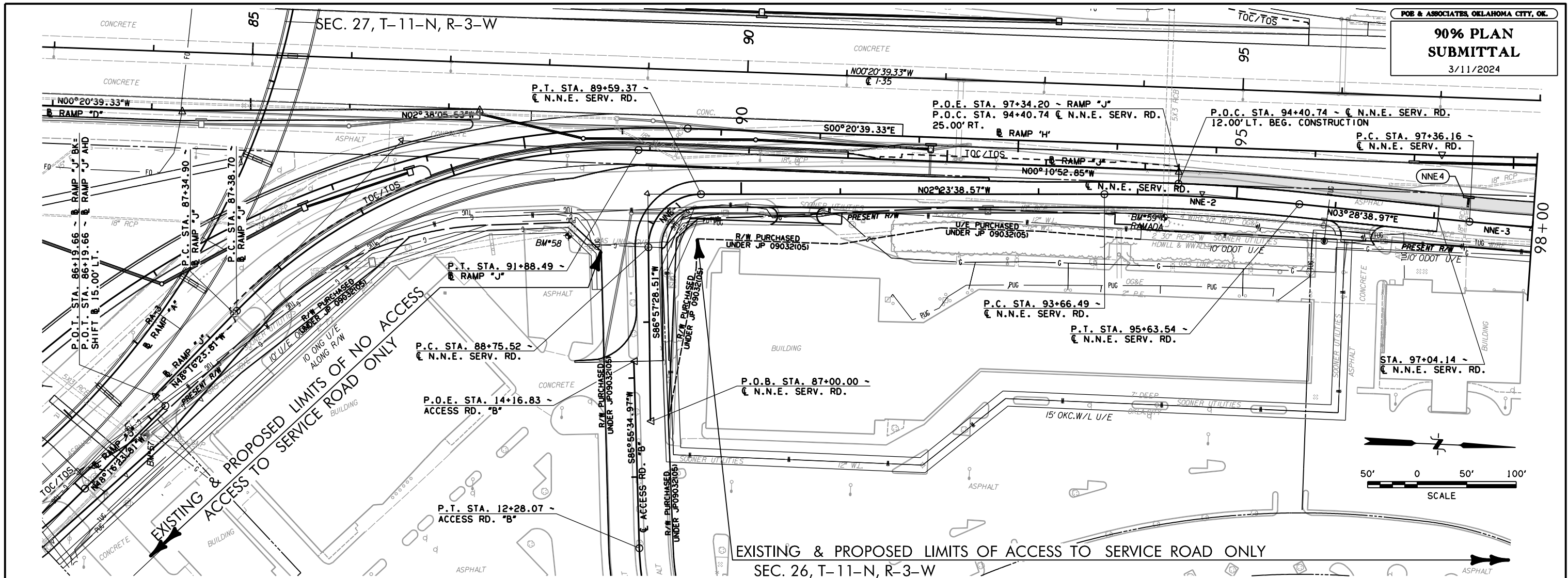

EXISTING & PROPOSED LIMITS OF ACCESS TO SERVICE ROAD ONLY
 SEC. 26, T-11-N, R-3-W

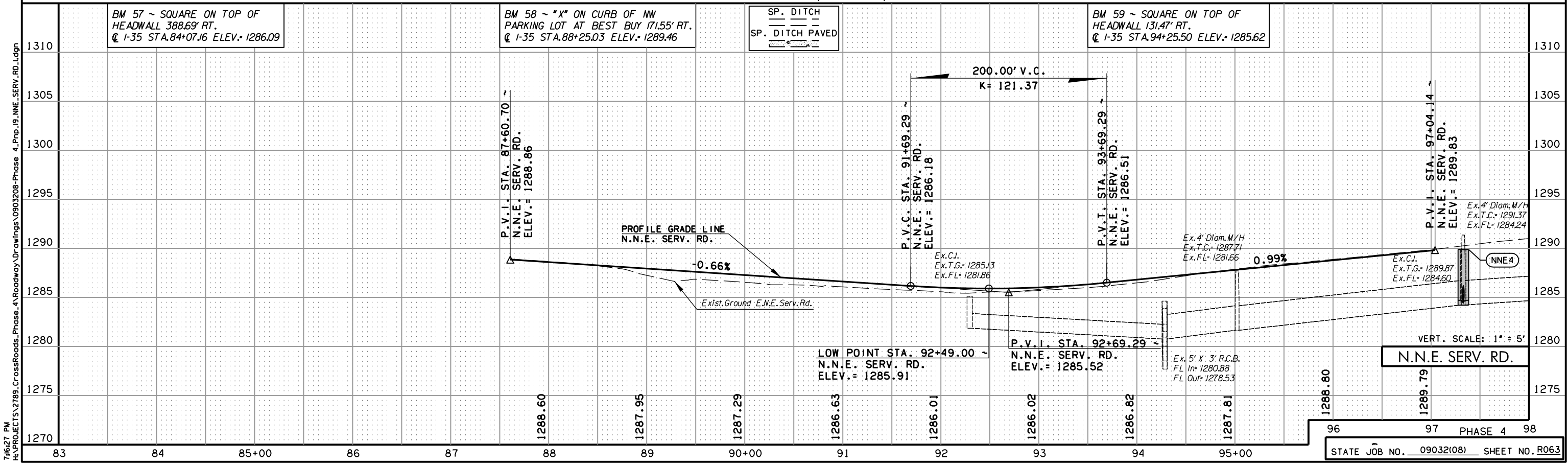

7:16:27 PM H:\PROJECTS\2789_Crossroads_Phase 4\Roadway\Drawings\0903208-Phase 4_Prop.IG_NNE.SERV.RD.dwg

90% PLAN SUBMITTAL

3/11/2024

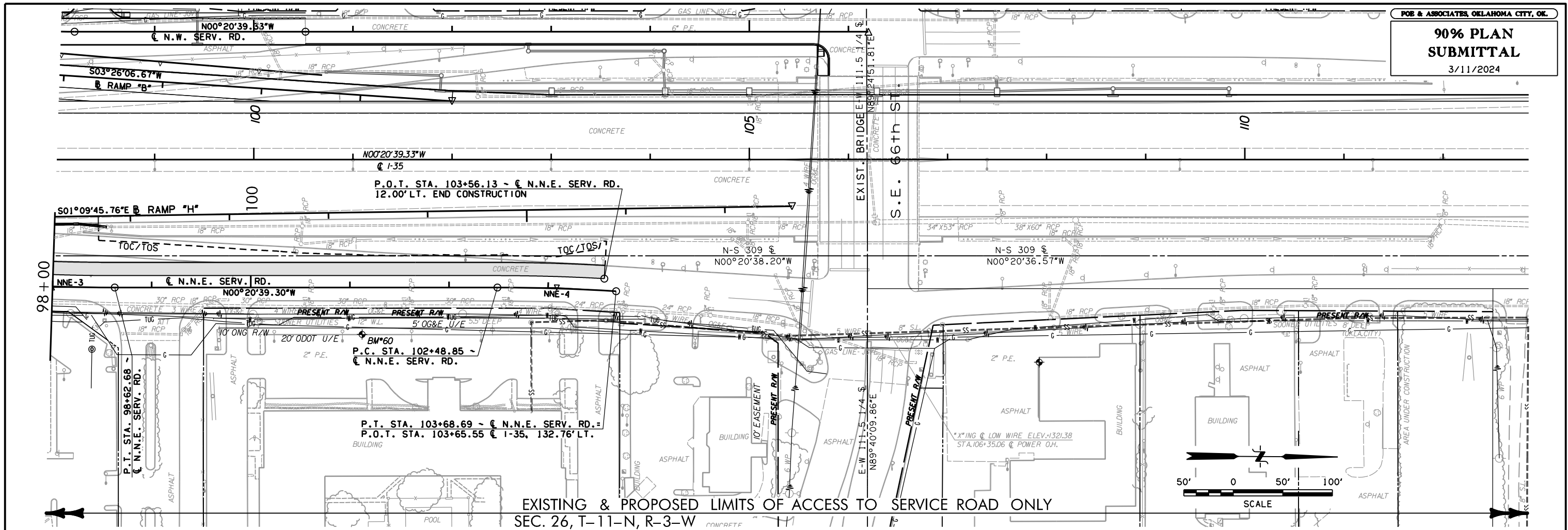

EXISTING & PROPOSED LIMITS OF ACCESS TO SERVICE ROAD ONLY
SEC. 26, T-11-N, R-3-W

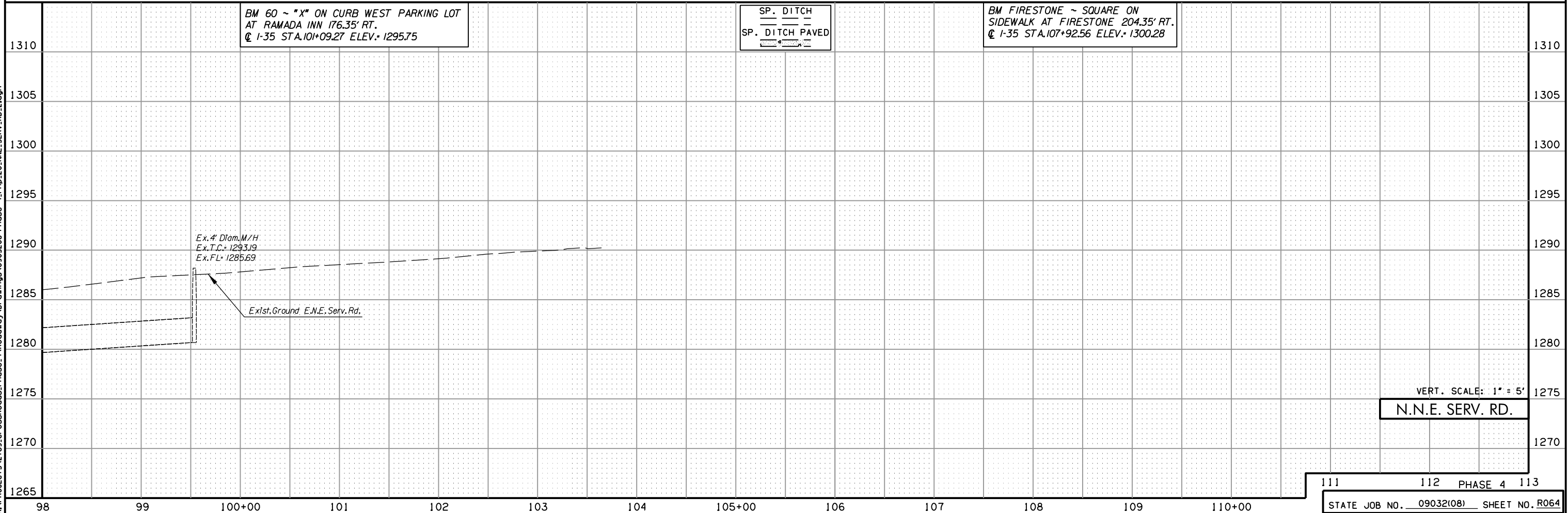
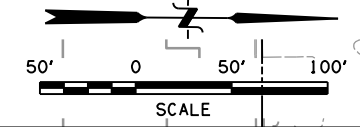

7:16:28 PM H:\PROJECTS\2789_Crossroads_Phase 4\Roadway\Drawings\0903208-Phase 4\Prop_20_NNE_SERV_RD_2.dgn

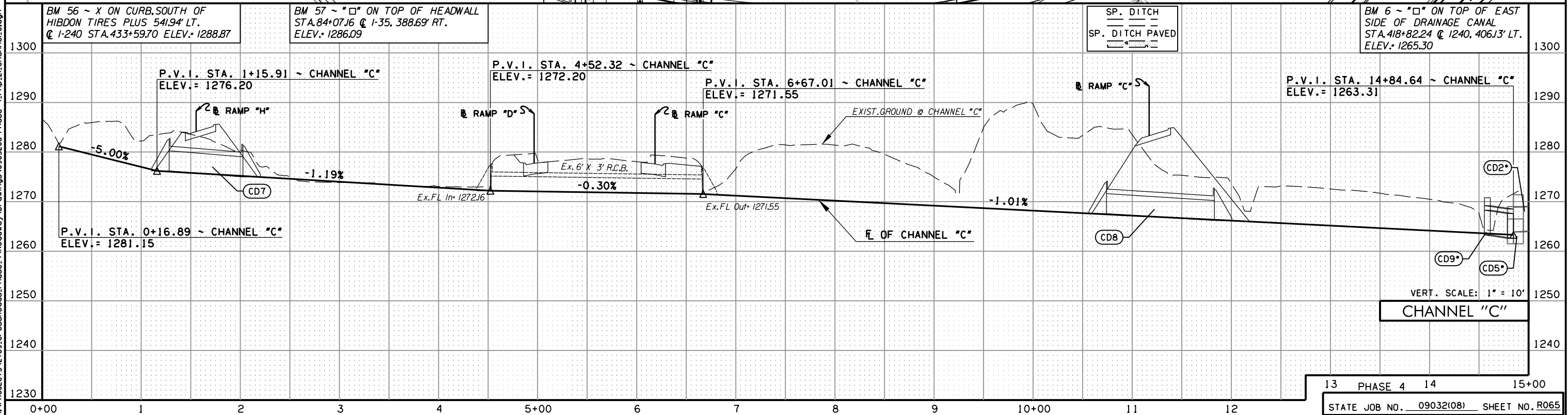
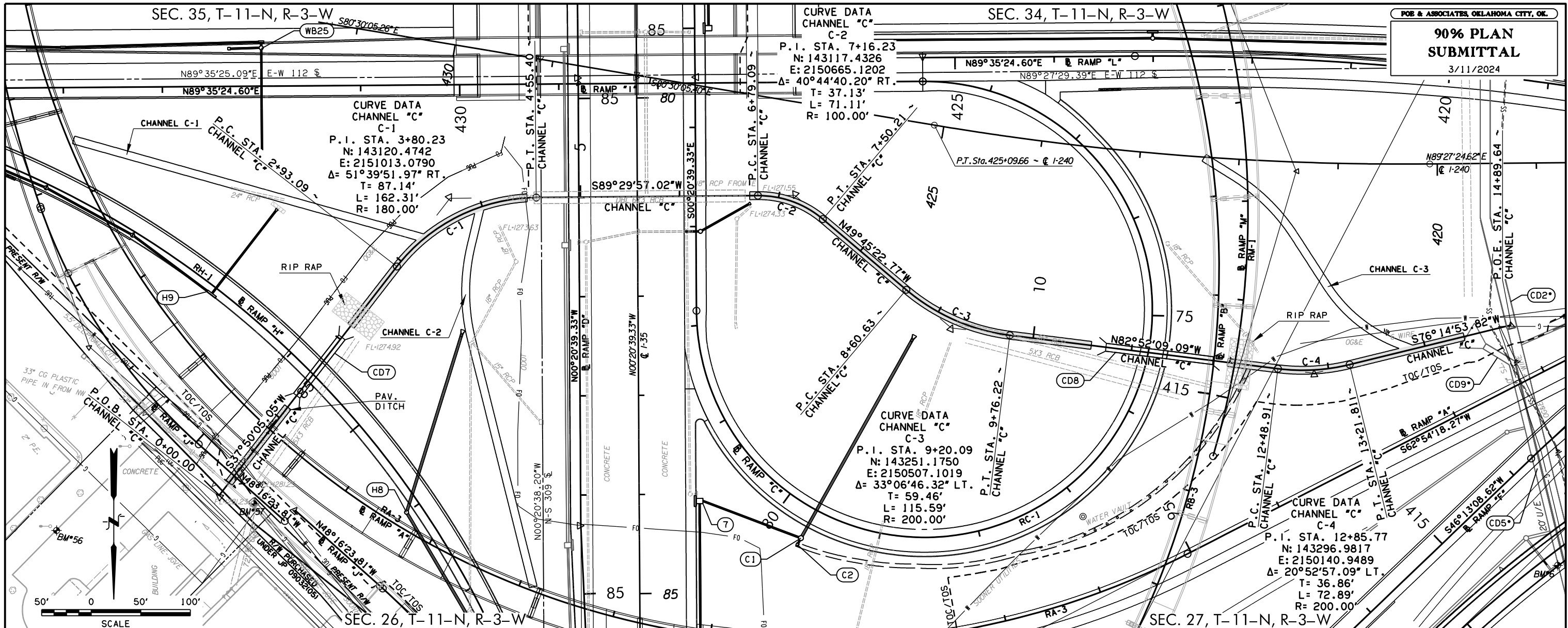

3/11/2024 7:16:32 PM H:\PROJECTS\2789_CrossRoads_Phase 4\Roadway\Drawings\0903208-Phase 4_Prop_21_Channel.C.dgn

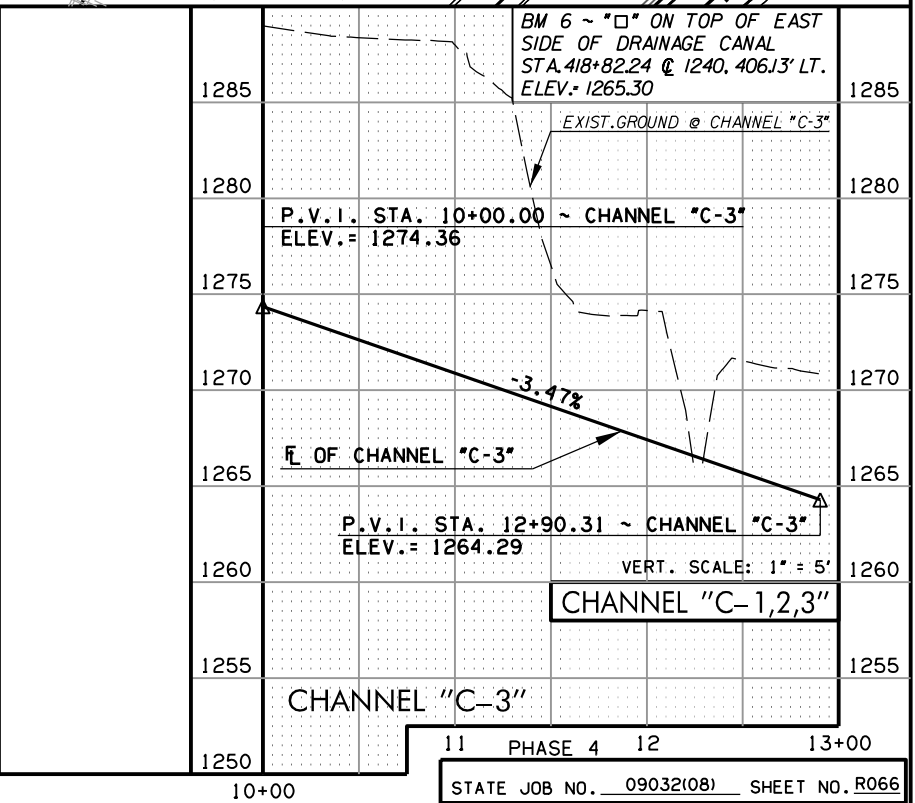
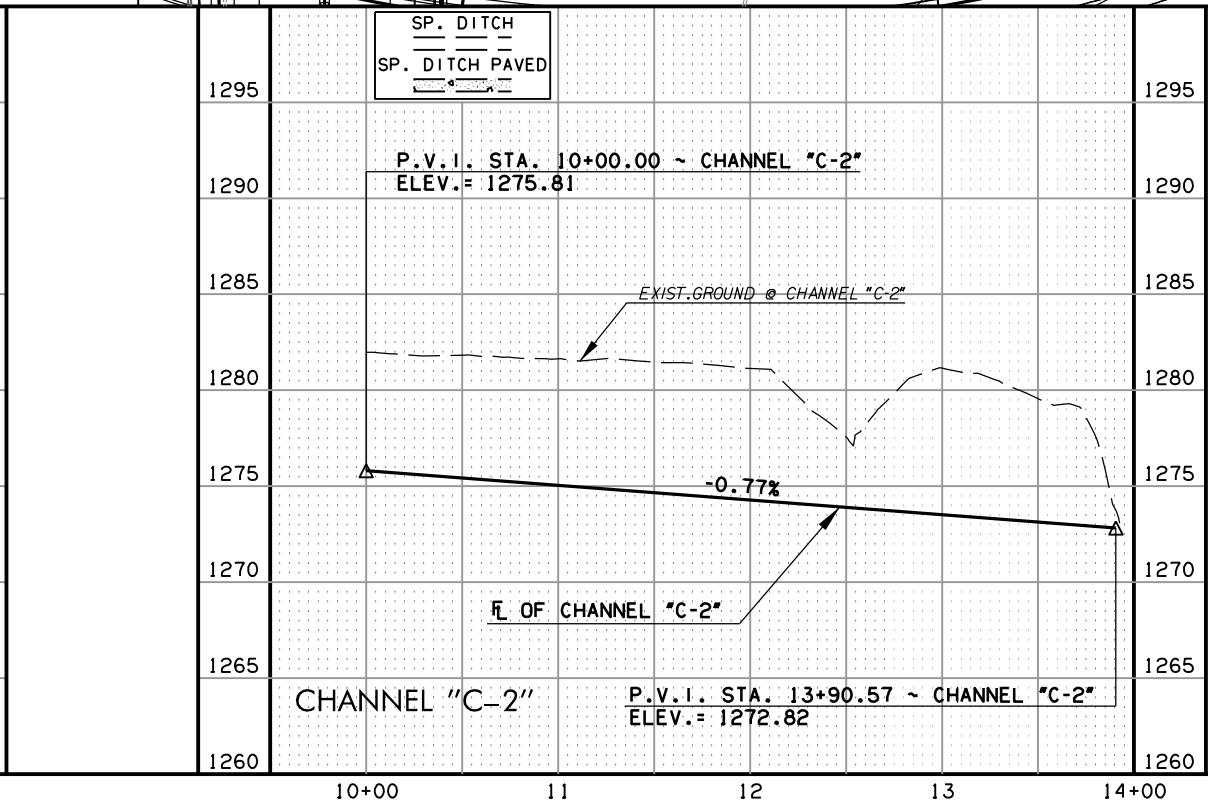
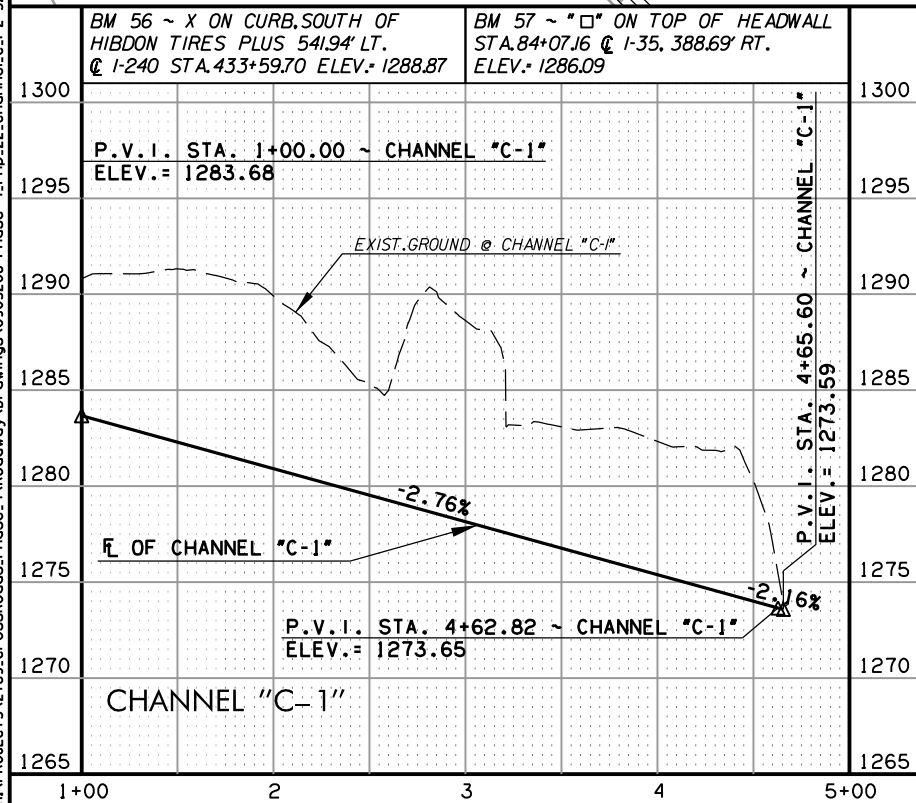
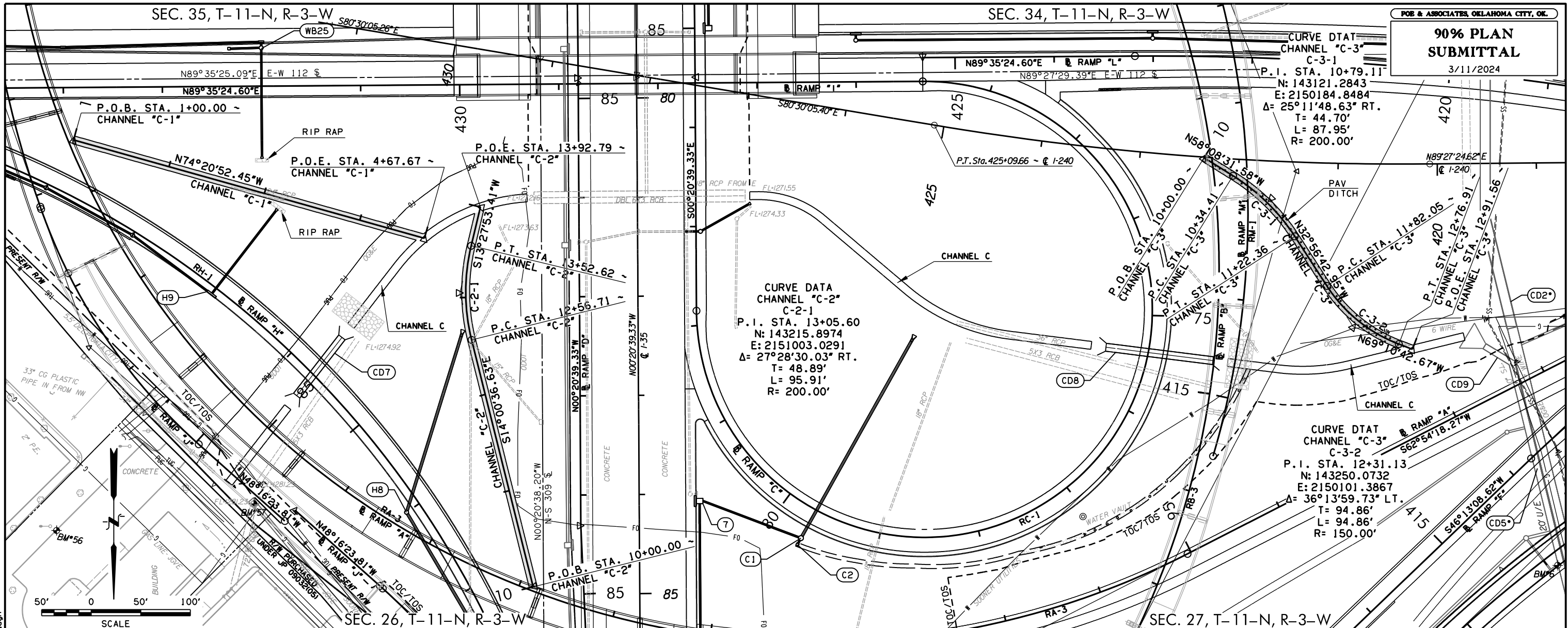

3/11/2024 7:16:36 PM H:\PROJECTS\2789_CrossRoads\Phase 4\Roadway\Drawings\0903208-Phase 4\Prop.22_Channel.C-1-2-3.dgn

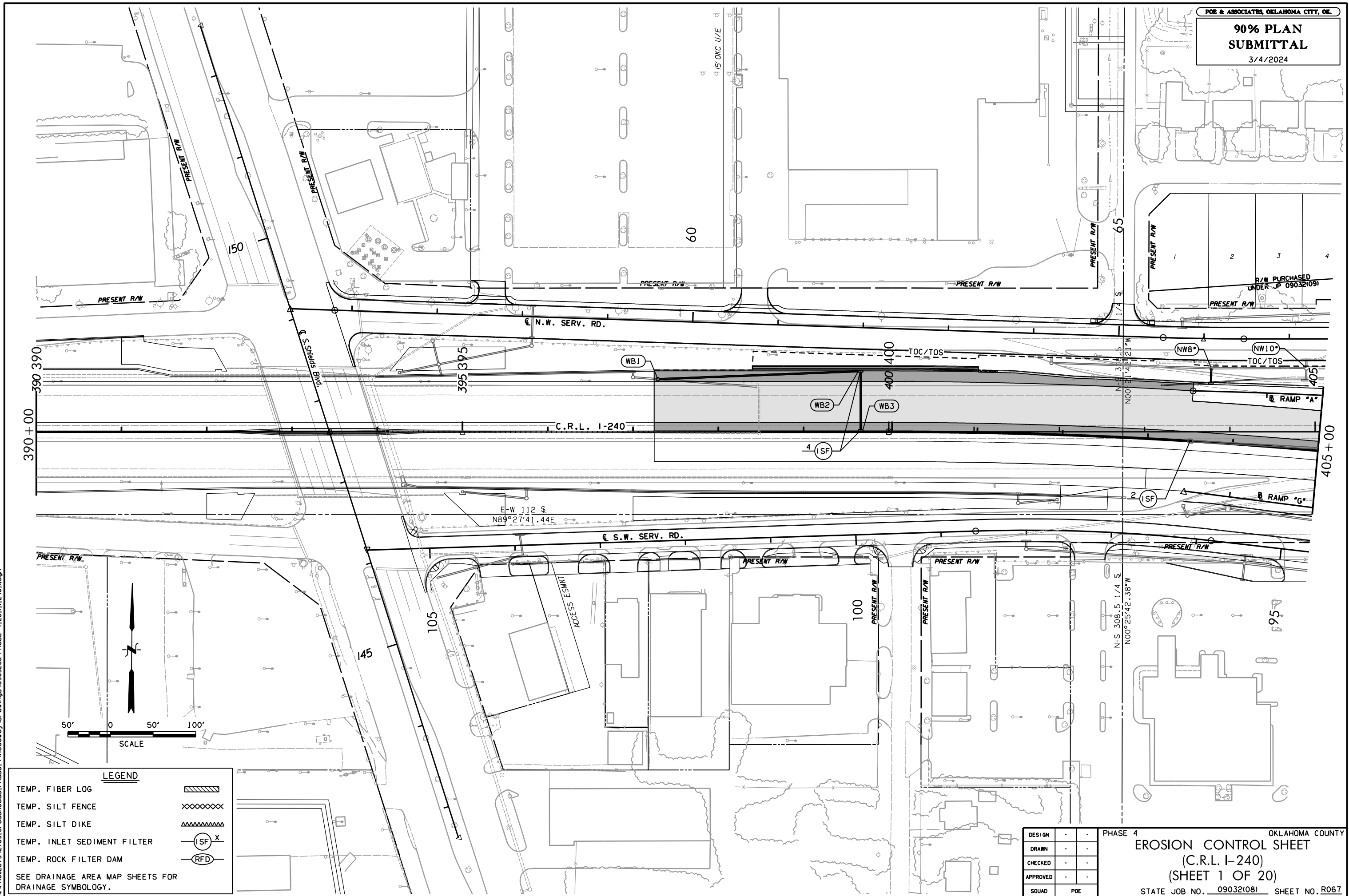

3/4/2024 2:39:43 PM H:\PROJECTS\2789_CrossRoads_Phase 4\Roadway\Drawings\0903208-Phase 4_EC.I.1.240.dgn

LEGEND

TEMP. FIBER LOG	
TEMP. SILT FENCE	
TEMP. SILT DIKE	
TEMP. INLET SEDIMENT FILTER	
TEMP. ROCK FILTER DAM	
SEE DRAINAGE AREA MAP SHEETS FOR DRAINAGE SYMBOLOLOGY.	

DESIGN	-	-
DRAWN	-	-
CHECKED	-	-
APPROVED	-	-
SQUAD	POE	

PHASE 4
EROSION CONTROL SHEET
 (C.R.L. I-240)
 (SHEET 1 OF 20)
 STATE JOB NO. 09032108 SHEET NO. R067

OKLAHOMA COUNTY

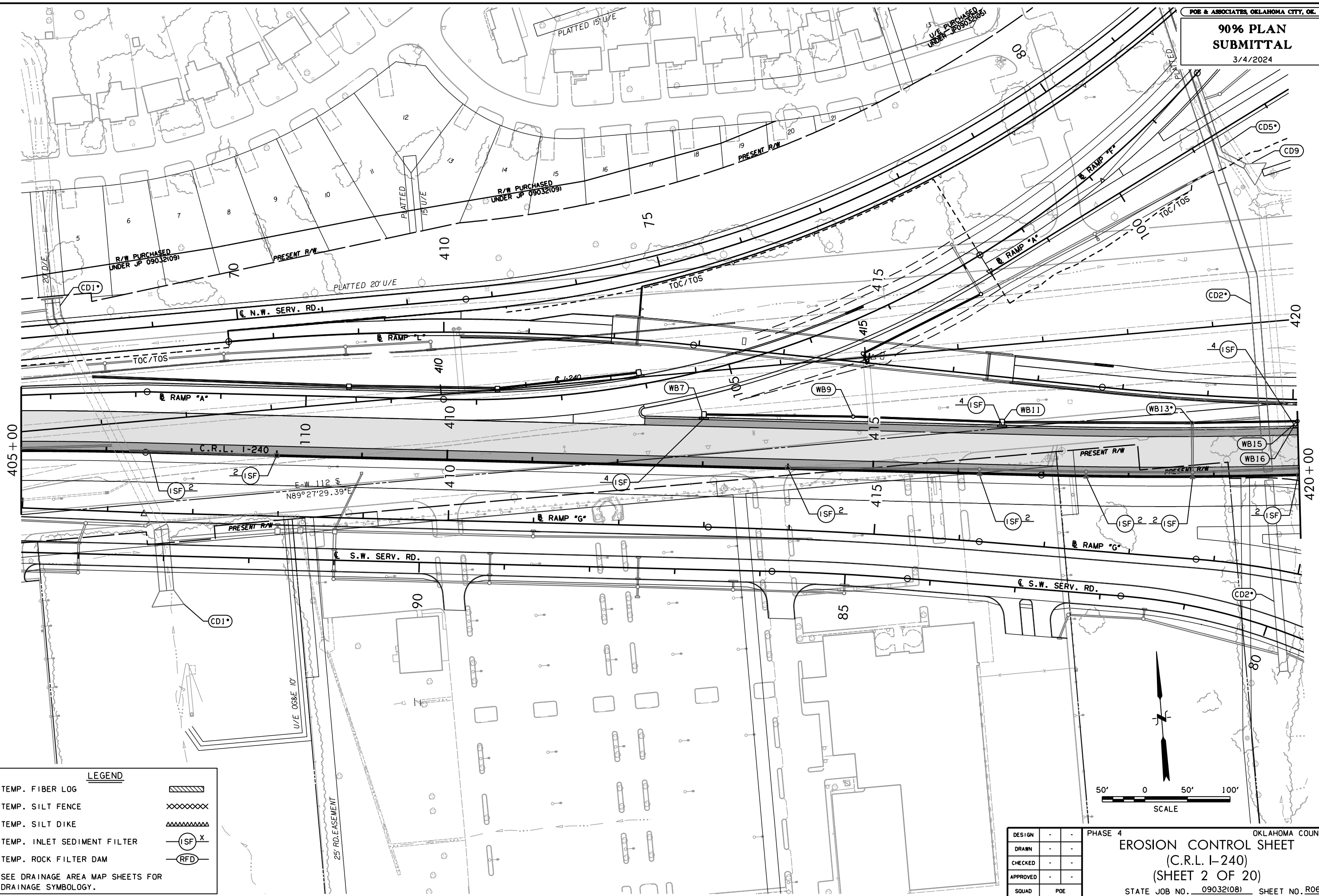

3/4/2024 2:39:47 PM
 H:\PROJECTS\2789_CrossRoads_Phase 4\Roadway\Drawings\0903208-Phase 4.EC.2.1-240.2.dgn

LEGEND	
TEMP. FIBER LOG	
TEMP. SILT FENCE	
TEMP. SILT DIKE	
TEMP. INLET SEDIMENT FILTER	
TEMP. ROCK FILTER DAM	
SEE DRAINAGE AREA MAP SHEETS FOR DRAINAGE SYMBOLLOGY.	

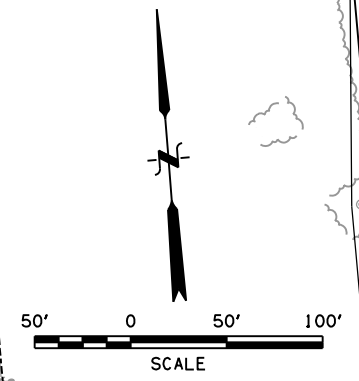

DESIGN	-	-	PHASE 4	OKLAHOMA COUNTY
DRAWN	-	-	EROSION CONTROL SHEET (C.R.L. I-240) (SHEET 2 OF 20)	STATE JOB NO. 090321081 SHEET NO. R068
CHECKED	-	-		
APPROVED	-	-		
SQUAD	POE			

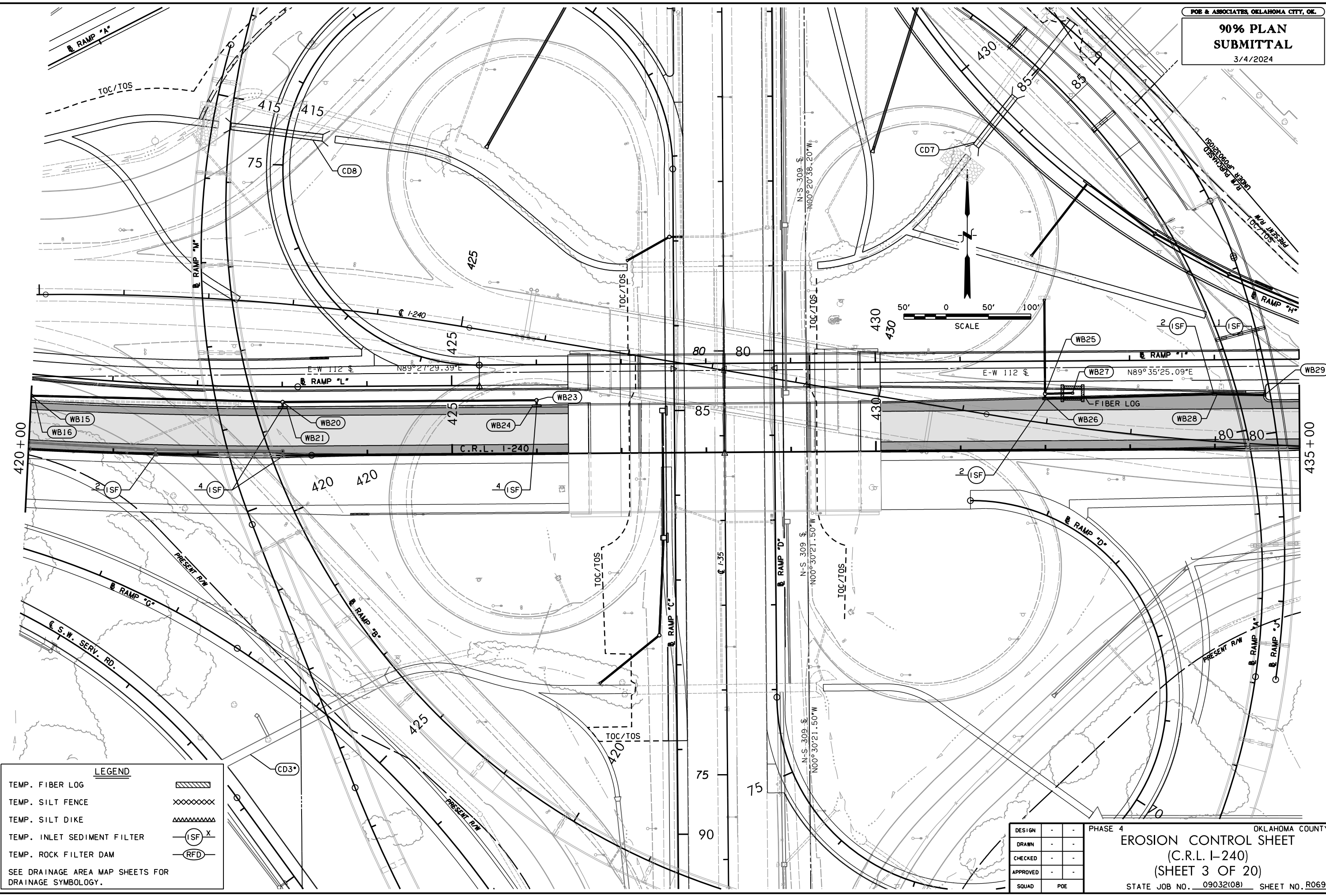

3/4/2024 2:39:50 PM
 H:\PROJECTS\2789_CrossRoads_Phase 4\Roadway\Drawings\0903208-Phase 4_EC_3.1.240_3.dgn

LEGEND

TEMP. FIBER LOG	
TEMP. SILT FENCE	
TEMP. SILT DIKE	
TEMP. INLET SEDIMENT FILTER	
TEMP. ROCK FILTER DAM	

SEE DRAINAGE AREA MAP SHEETS FOR DRAINAGE SYMBOLOLOGY.

DESIGN	-	-
DRAWN	-	-
CHECKED	-	-
APPROVED	-	-
SQUAD	POE	

PHASE 4
EROSION CONTROL SHEET
 (C.R.L. I-240)
 (SHEET 3 OF 20)
 STATE JOB NO. 090321081 SHEET NO. R069

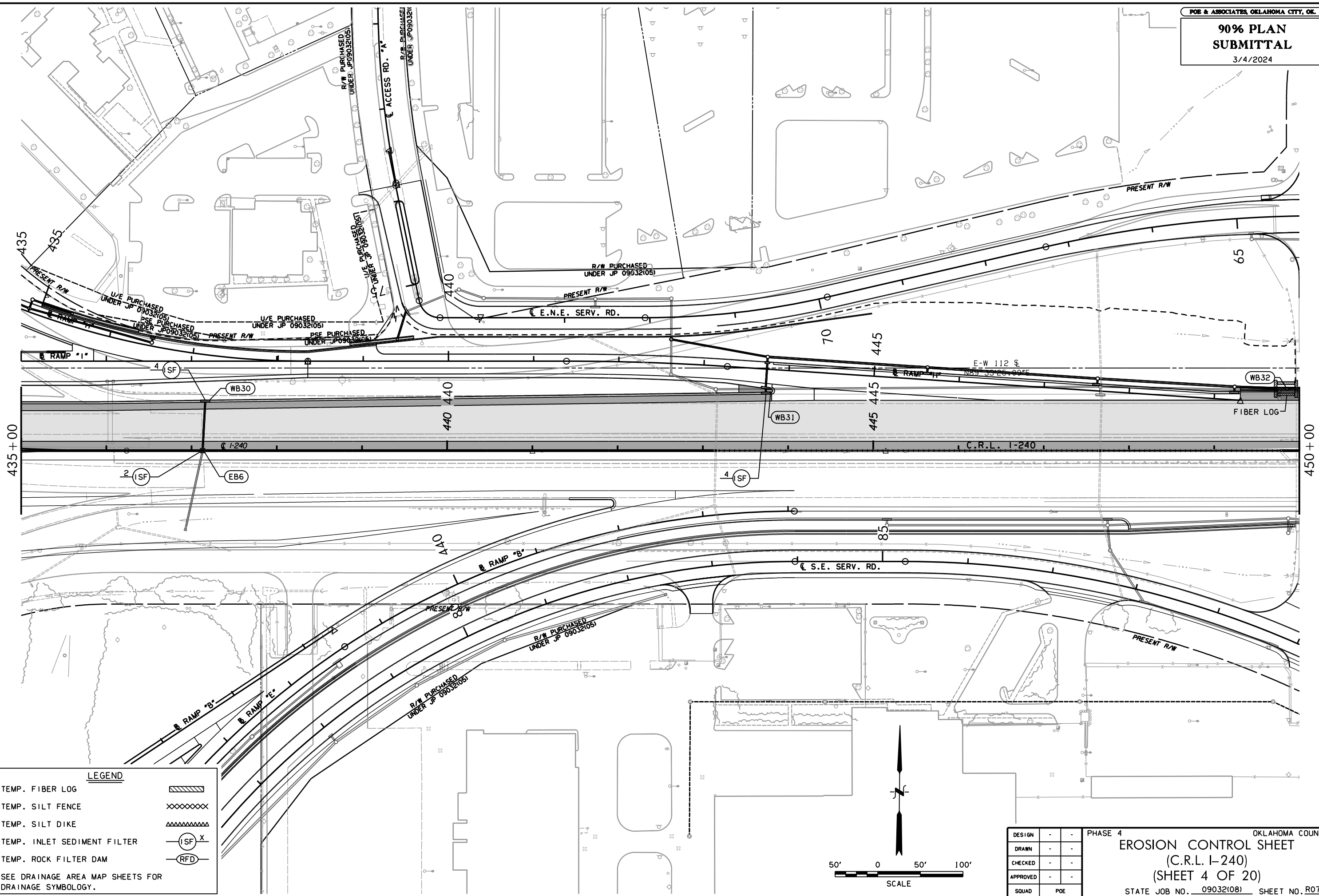

3/4/2024 2:39:53 PM H:\PROJECTS\2789_CrossRoads_Phase 4\Roadway\Drawings\0903208-Phase 4_EC_4.1_240_4.dgn

LEGEND	
TEMP. FIBER LOG	
TEMP. SILT FENCE	
TEMP. SILT DIKE	
TEMP. INLET SEDIMENT FILTER	
TEMP. ROCK FILTER DAM	
SEE DRAINAGE AREA MAP SHEETS FOR DRAINAGE SYMBOLOLOGY.	

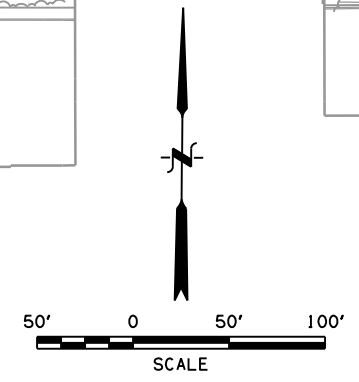

DESIGN	-	-	PHASE 4	OKLAHOMA COUNTY
DRAWN	-	-	EROSION CONTROL SHEET (C.R.L. I-240) (SHEET 4 OF 20) STATE JOB NO. 090321081 SHEET NO. R070	
CHECKED	-	-		
APPROVED	-	-		
SQUAD	POE			

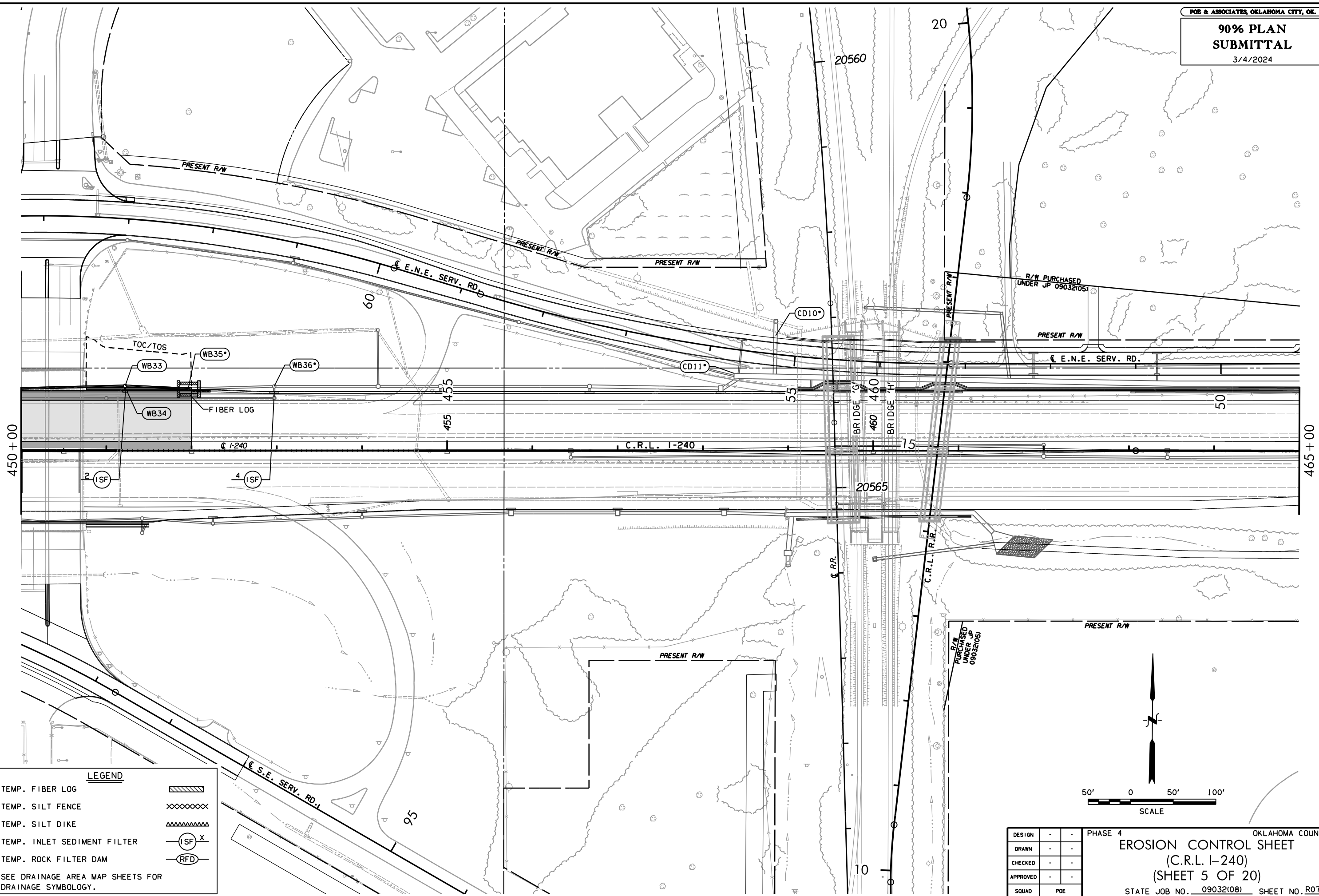

3/4/2024 2:39:55 PM
 H:\PROJECTS\2789_Crossroads_Phase 4\Roadway\Drawings\0903208-Phase 4_EC-I-240_5.dgn

LEGEND

TEMP. FIBER LOG	
TEMP. SILT FENCE	
TEMP. SILT DIKE	
TEMP. INLET SEDIMENT FILTER	
TEMP. ROCK FILTER DAM	

SEE DRAINAGE AREA MAP SHEETS FOR DRAINAGE SYMBOLOLOGY.

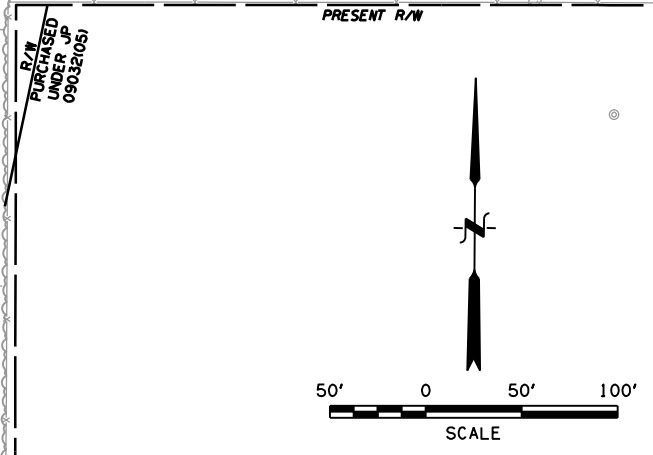

DESIGN	-	-
DRAWN	-	-
CHECKED	-	-
APPROVED	-	-
SQUAD	POE	

PHASE 4
EROSION CONTROL SHEET
 (C.R.L. I-240)
 (SHEET 5 OF 20)
 STATE JOB NO. 09032108 SHEET NO. R071

3/4/2024 2:39:57 PM H:\PROJECTS\2789_CrossRoads_Phase 4\Roadway\Drawings\0903208-Phase 4_EC-6-1-35_1.dgn

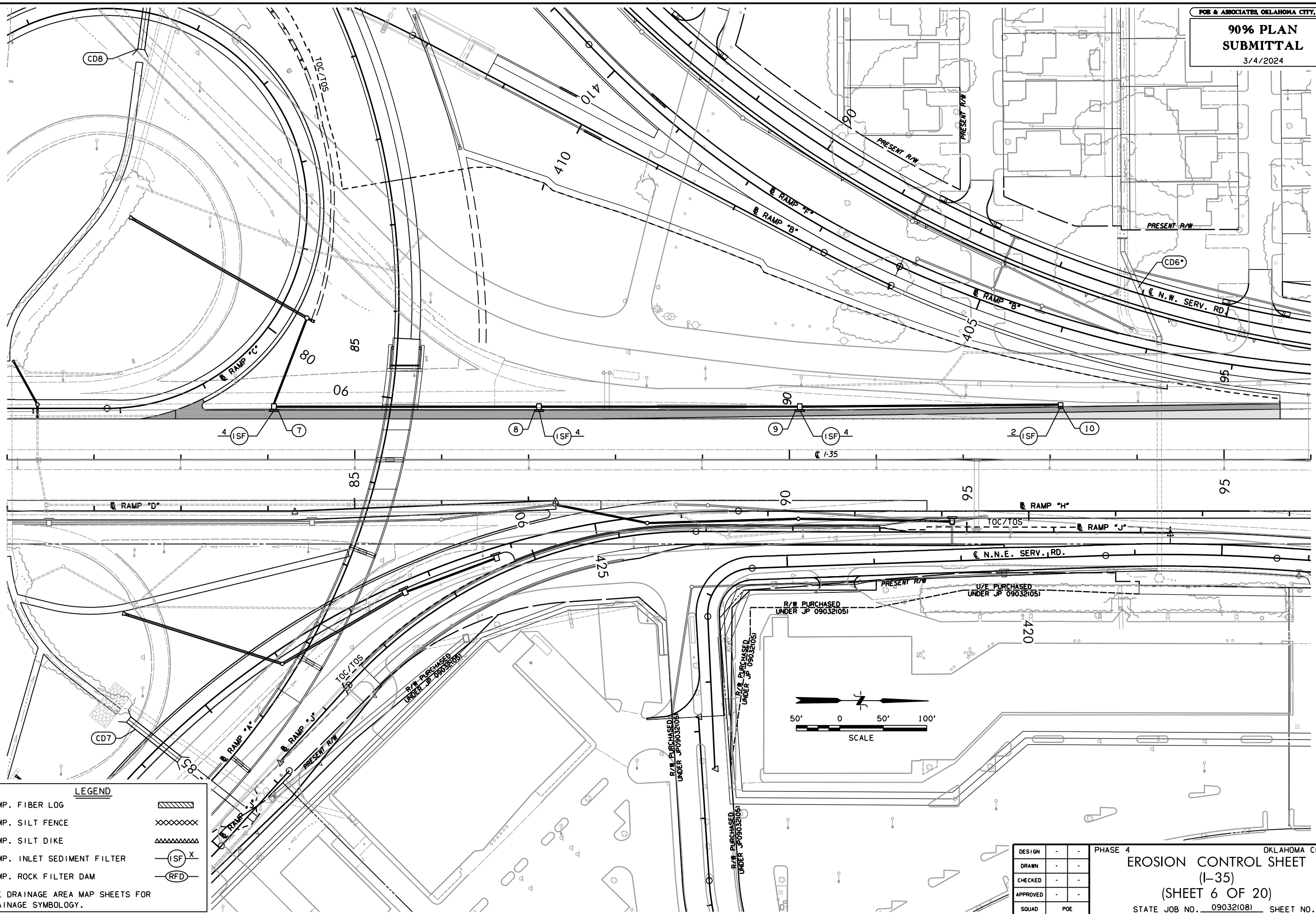

LEGEND

- TEMP. FIBER LOG
 - TEMP. SILT FENCE
 - TEMP. SILT DIKE
 - TEMP. INLET SEDIMENT FILTER
 - TEMP. ROCK FILTER DAM
- SEE DRAINAGE AREA MAP SHEETS FOR DRAINAGE SYMBOLOLOGY.

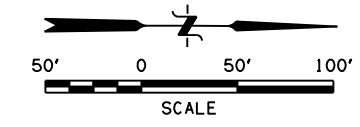

DESIGN	-	-
DRAWN	-	-
CHECKED	-	-
APPROVED	-	-
SQUAD	POE	

PHASE 4
EROSION CONTROL SHEET
 (I-35)
 (SHEET 6 OF 20)
 STATE JOB NO. 090321081 SHEET NO. R072

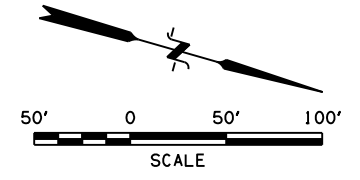

3/4/2024 2:39:59 PM H:\PROJECTS\2789_CrossRoads_Phase 4\Roadway\Drawings\0903208-Phase 4.EC.7.Ramp-A.1.dgn

LEGEND	
TEMP. FIBER LOG	
TEMP. SILT FENCE	
TEMP. SILT DIKE	
TEMP. INLET SEDIMENT FILTER	
TEMP. ROCK FILTER DAM	
SEE DRAINAGE AREA MAP SHEETS FOR DRAINAGE SYMBOLOLOGY.	

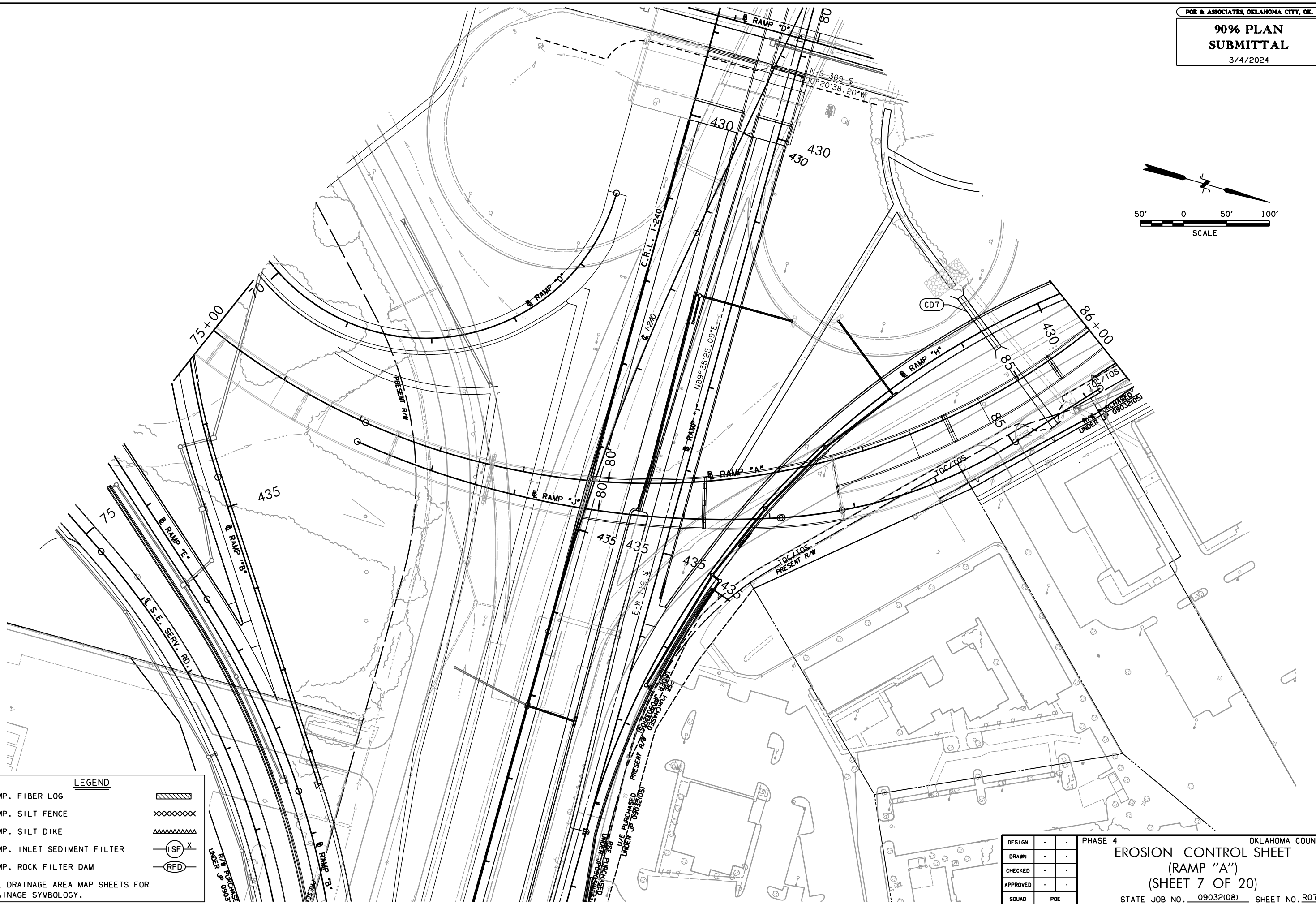

DESIGN	-	-
DRAWN	-	-
CHECKED	-	-
APPROVED	-	-
SQUAD	POE	

PHASE 4
EROSION CONTROL SHEET
 (RAMP "A")
 (SHEET 7 OF 20)
 STATE JOB NO. 090321081 SHEET NO. R073

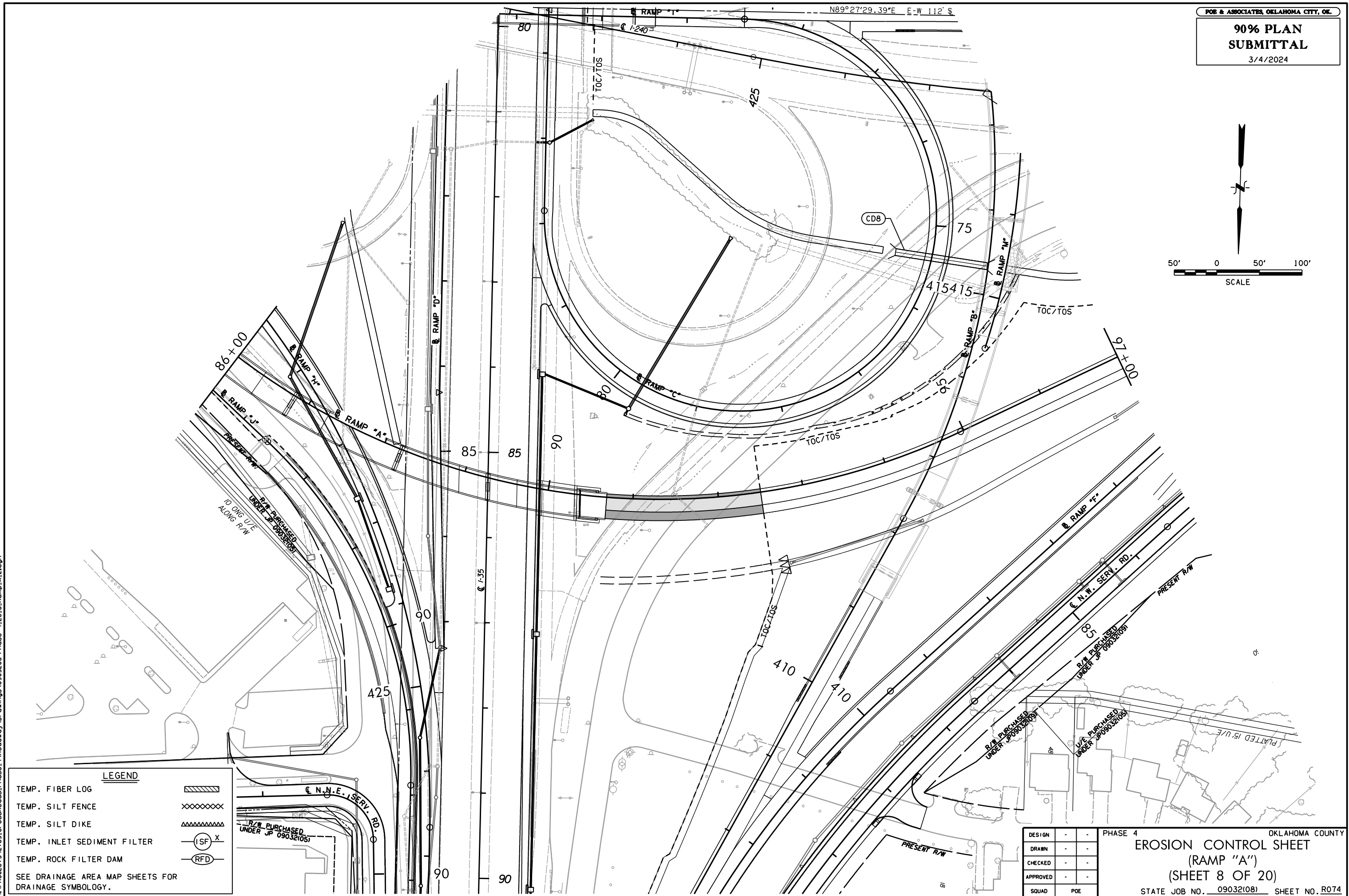
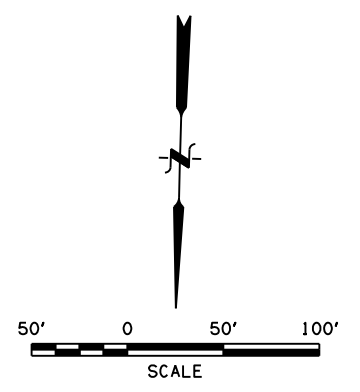

3/4/2024 2:40:01 PM H:\PROJECTS\2789_CrossRoads_Phase 4\Roadway\Drawings\0903208-Phase 4_EC-Ramp-A_2.dgn

LEGEND	
TEMP. FIBER LOG	
TEMP. SILT FENCE	
TEMP. SILT DIKE	
TEMP. INLET SEDIMENT FILTER	
TEMP. ROCK FILTER DAM	
SEE DRAINAGE AREA MAP SHEETS FOR DRAINAGE SYMBOLOLOGY.	

DESIGN	-	-
DRAWN	-	-
CHECKED	-	-
APPROVED	-	-
SQUAD	POE	

PHASE 4
EROSION CONTROL SHEET
 (RAMP "A")
 (SHEET 8 OF 20)
 STATE JOB NO. 09032108 SHEET NO. R074

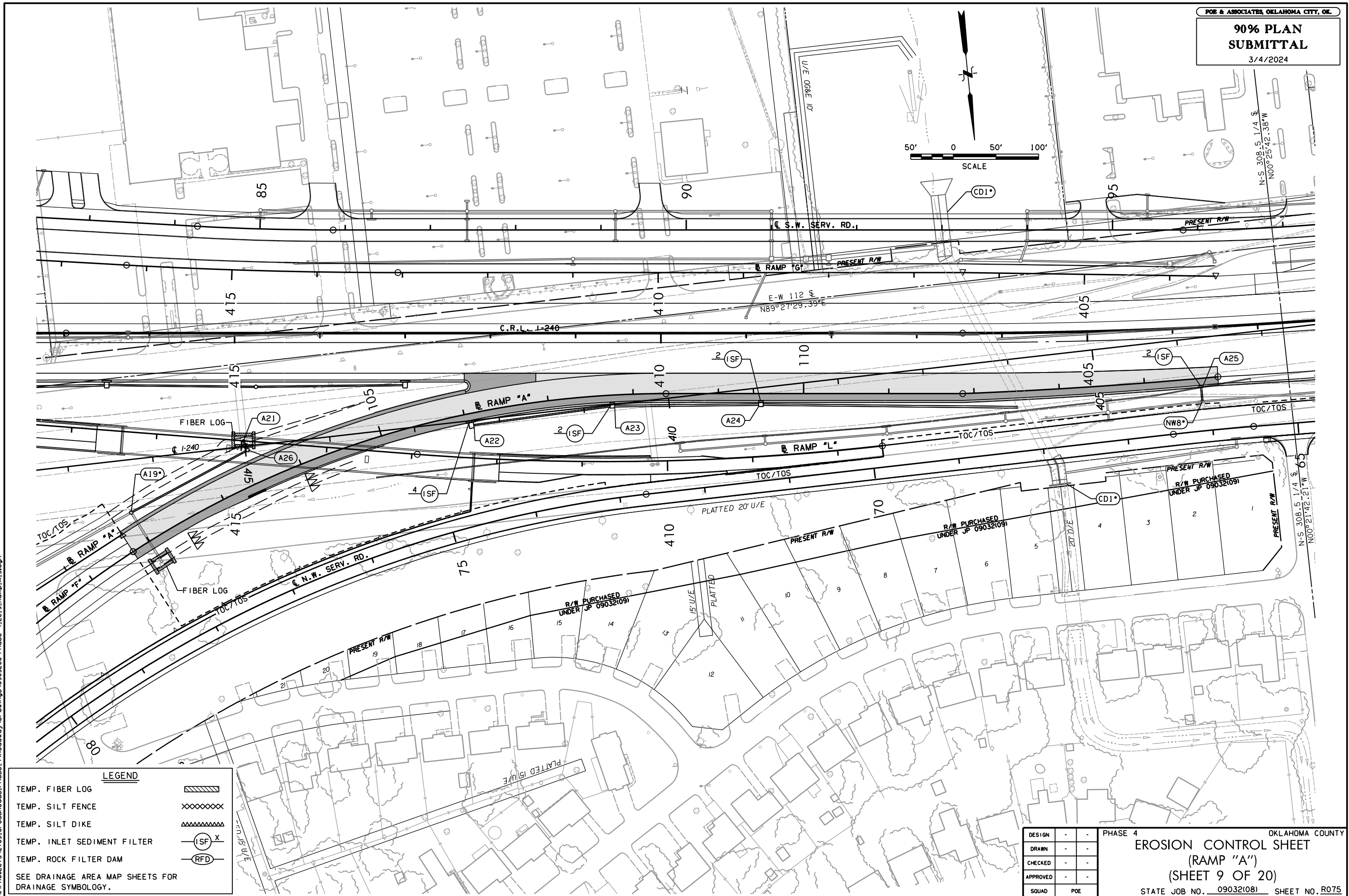
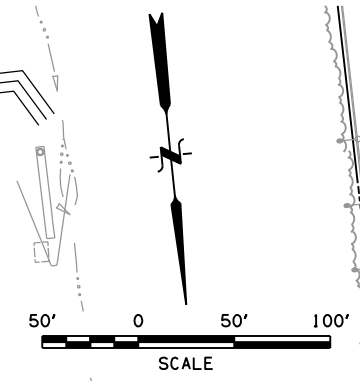

3/4/2024 2:40:04 PM
 H:\PROJECTS\2789_CrossRoads_Phase 4\Roadway\Drawings\0903208-Phase 4_EC-9_Ramp_A_3.dgn

LEGEND	
TEMP. FIBER LOG	
TEMP. SILT FENCE	
TEMP. SILT DIKE	
TEMP. INLET SEDIMENT FILTER	
TEMP. ROCK FILTER DAM	
SEE DRAINAGE AREA MAP SHEETS FOR DRAINAGE SYMBOLOLOGY.	

DESIGN	-	-	PHASE 4	OKLAHOMA COUNTY
DRAWN	-	-	EROSION CONTROL SHEET (RAMP "A") (SHEET 9 OF 20)	
CHECKED	-	-		
APPROVED	-	-		
SQUAD	POE		STATE JOB NO. 090321081	SHEET NO. R075

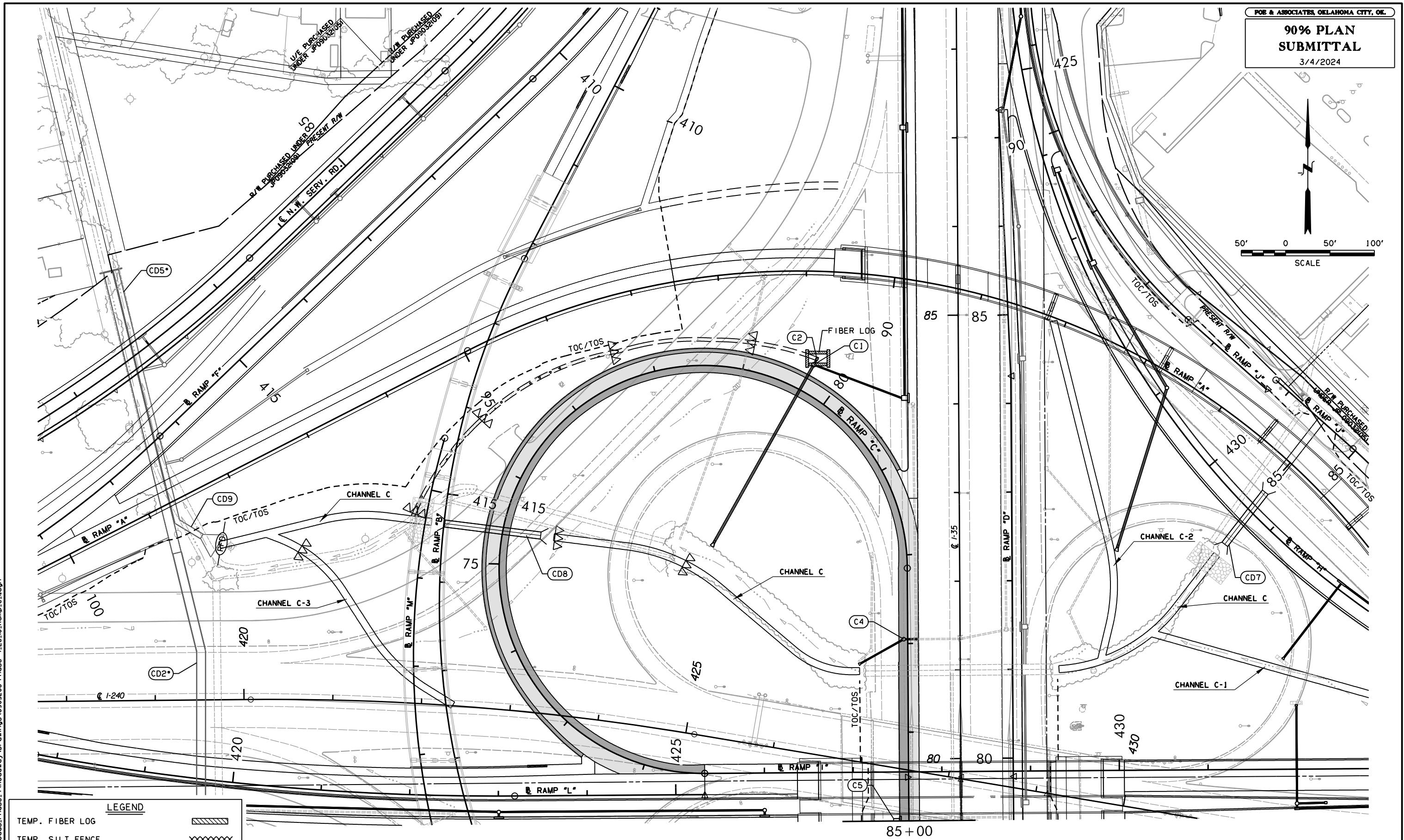
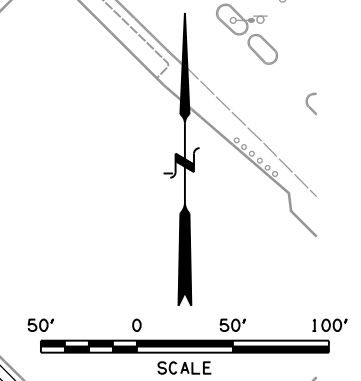

LEGEND

TEMP. FIBER LOG	
TEMP. SILT FENCE	
TEMP. SILT DIKE	
TEMP. INLET SEDIMENT FILTER	
TEMP. ROCK FILTER DAM	

SEE DRAINAGE AREA MAP SHEETS FOR DRAINAGE SYMBOLOLOGY.

DESIGN	-	-	PHASE 4	OKLAHOMA COUNTY
DRAWN	-	-	EROSION CONTROL SHEET (RAMP "C") (SHEET 10 OF 20)	
CHECKED	-	-		
APPROVED	-	-		
SQUAD	POE		STATE JOB NO. 09032108	SHEET NO. R076

3/4/2024 2:40:06 PM
 H:\PROJECTS\2789_CrossRoads_Phase 4\Roadway\Drawings\0903208-Phase 4_EC10_Ramp_C.dgn

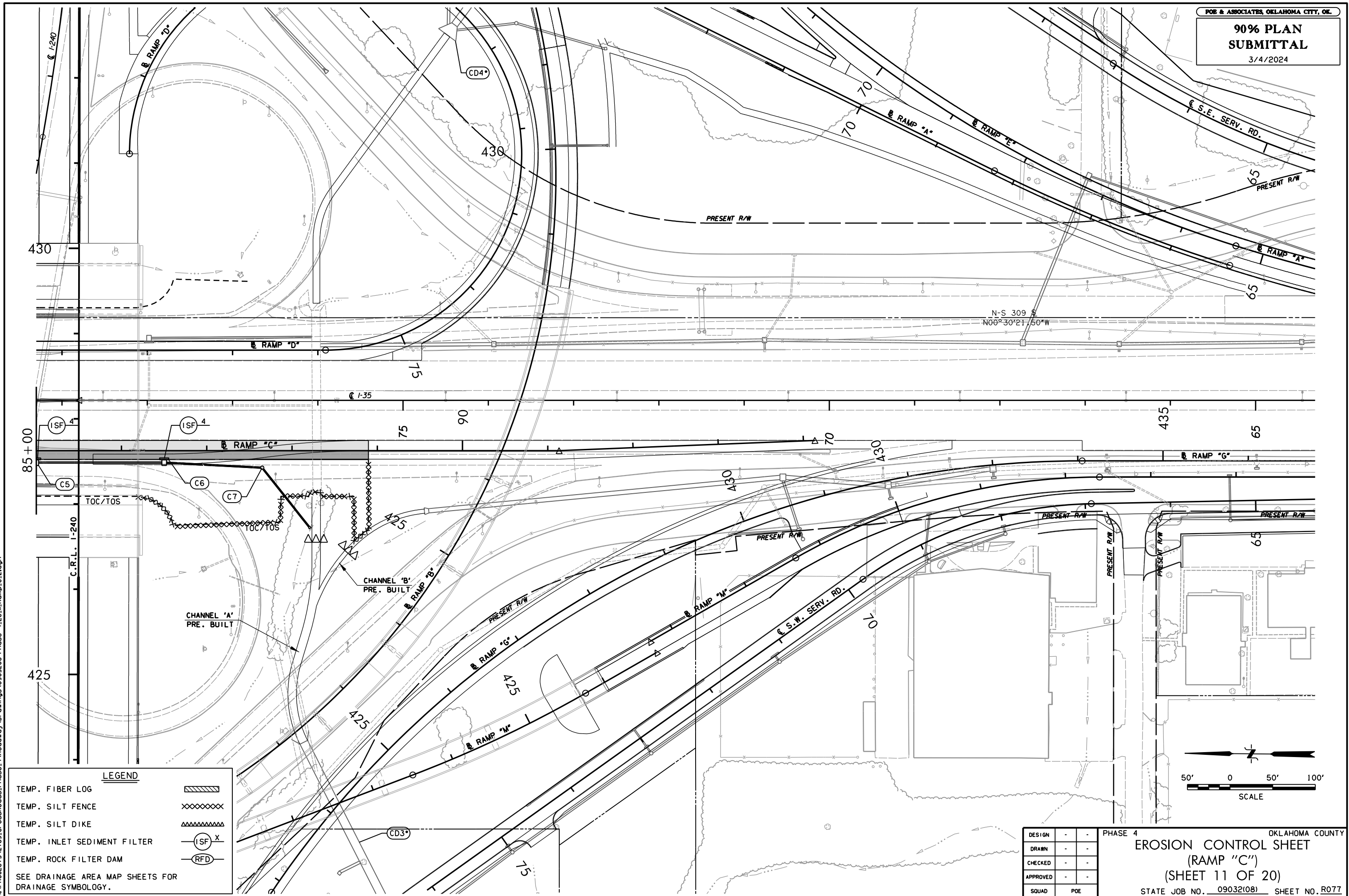

3/4/2024 2:40:09 PM
H:\PROJECTS\2789_CrossRoads_Phase 4\Roadway\Drawings\0903208-Phase 4_EC_IL_Ramp_C-2.dgn

LEGEND

TEMP. FIBER LOG	
TEMP. SILT FENCE	
TEMP. SILT DIKE	
TEMP. INLET SEDIMENT FILTER	
TEMP. ROCK FILTER DAM	

SEE DRAINAGE AREA MAP SHEETS FOR DRAINAGE SYMBOLLOGY.

DESIGN	-	-	PHASE 4
DRAWN	-	-	
CHECKED	-	-	
APPROVED	-	-	
SQUAD	POE		

OKLAHOMA COUNTY
EROSION CONTROL SHEET
 (RAMP "C")
 (SHEET 11 OF 20)
 STATE JOB NO. 090321081 SHEET NO. R077

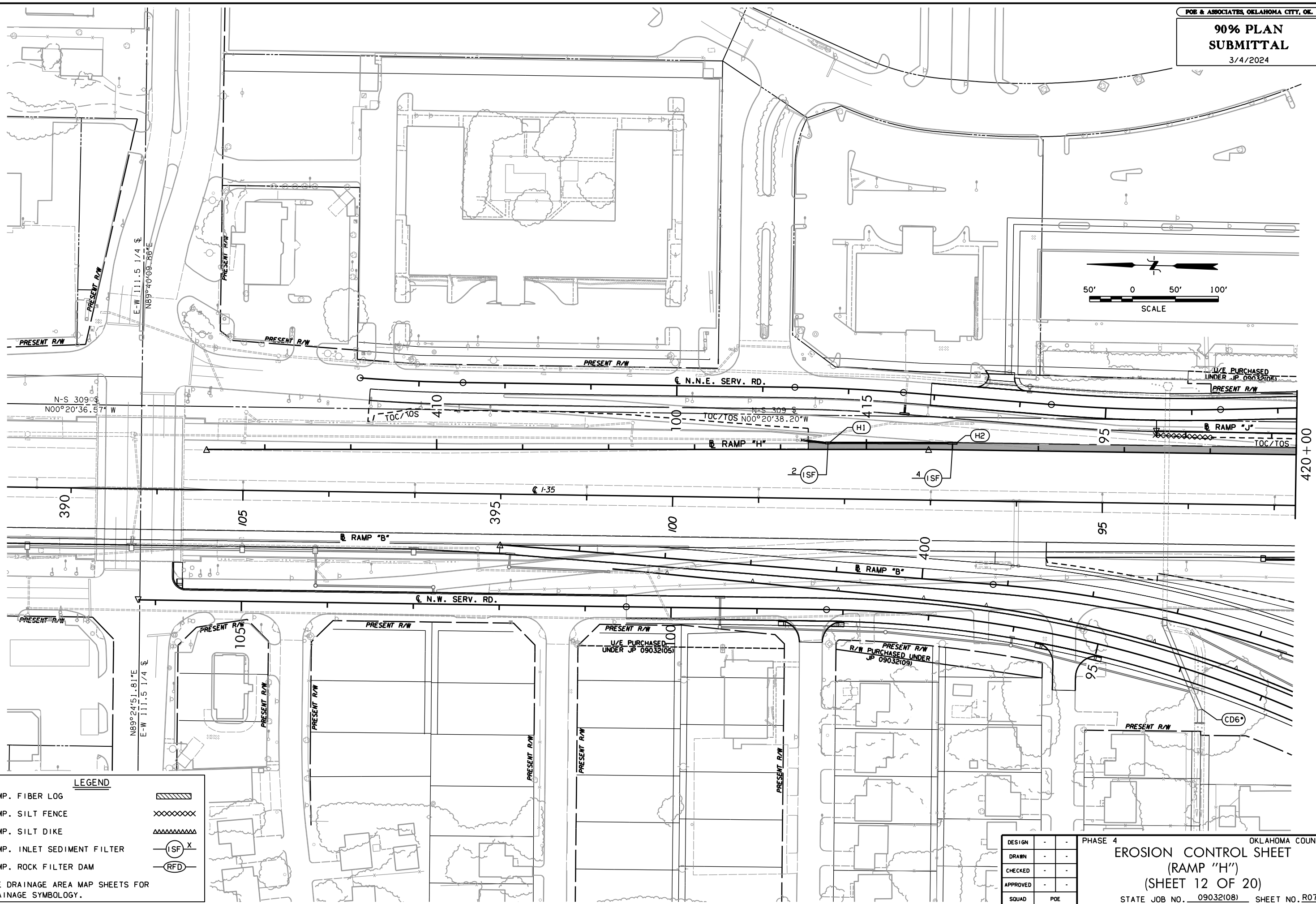
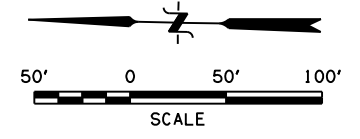

3/4/2024 2:40:11 PM
 H:\PROJECTS\2789_CrossRoads_Phase 4\Roadway\Drawings\0903208-Phase 4_EC12_Ramp_H-1.dgn

LEGEND

TEMP. FIBER LOG	
TEMP. SILT FENCE	
TEMP. SILT DIKE	
TEMP. INLET SEDIMENT FILTER	
TEMP. ROCK FILTER DAM	

SEE DRAINAGE AREA MAP SHEETS FOR DRAINAGE SYMBOLLOGY.

DESIGN	-	-
DRAWN	-	-
CHECKED	-	-
APPROVED	-	-
SQUAD	POE	

PHASE 4
EROSION CONTROL SHEET
 (RAMP "H")
 (SHEET 12 OF 20)
 OKLAHOMA COUNTY
 STATE JOB NO. 090321081 SHEET NO. R078

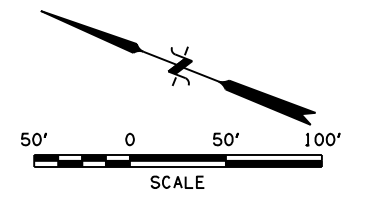

3/4/2024 2:40:16 PM H:\PROJECTS\2789_CrossRoads_Phase 4\Roadway\Drawings\0903208-Phase 4_EC_13_Ramp_H.2.dgn

LEGEND

TEMP. FIBER LOG	
TEMP. SILT FENCE	
TEMP. SILT DIKE	
TEMP. INLET SEDIMENT FILTER	
TEMP. ROCK FILTER DAM	

SEE DRAINAGE AREA MAP SHEETS FOR DRAINAGE SYMBOLOLOGY.

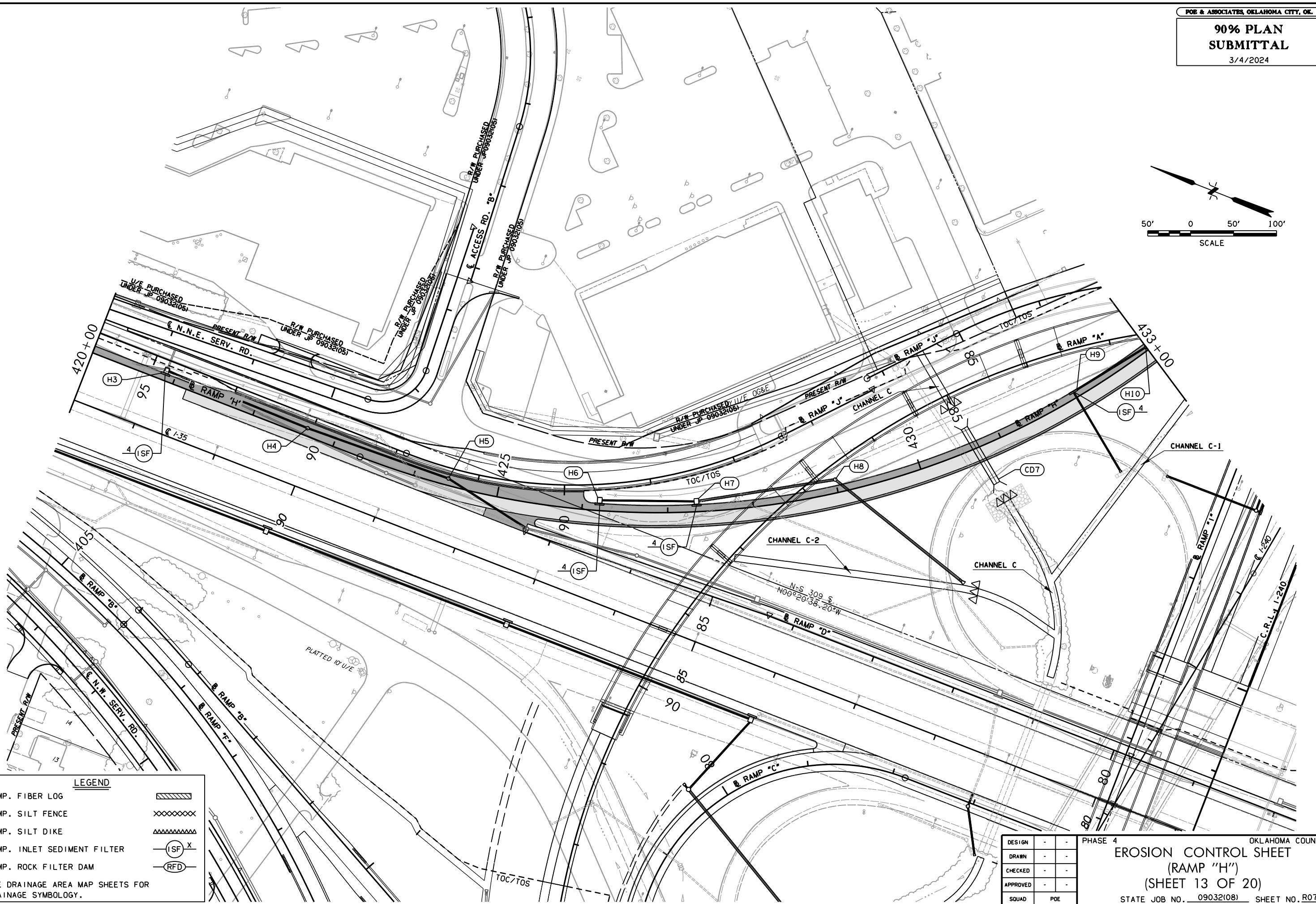

DESIGN	-	-
DRAWN	-	-
CHECKED	-	-
APPROVED	-	-
SQUAD	POE	

PHASE 4
EROSION CONTROL SHEET
 (RAMP "H")
 (SHEET 13 OF 20)
 STATE JOB NO. 090321081 SHEET NO. R079

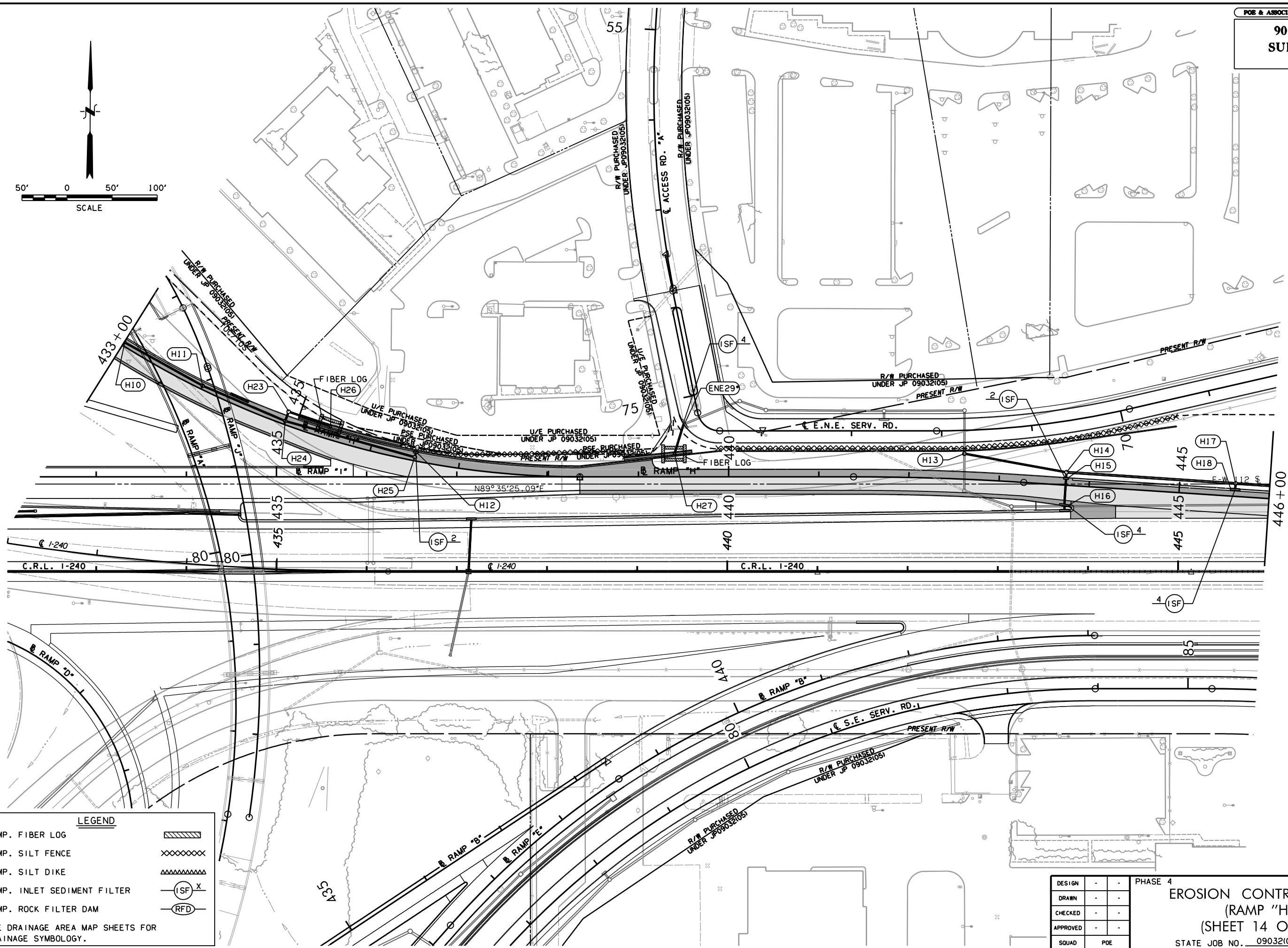
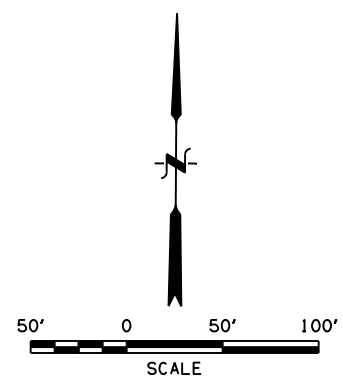

LEGEND

TEMP. FIBER LOG	
TEMP. SILT FENCE	
TEMP. SILT DIKE	
TEMP. INLET SEDIMENT FILTER	
TEMP. ROCK FILTER DAM	
SEE DRAINAGE AREA MAP SHEETS FOR DRAINAGE SYMBOLOLOGY.	

DESIGN	-	-
DRAWN	-	-
CHECKED	-	-
APPROVED	-	-
SQUAD	POE	

PHASE 4
EROSION CONTROL SHEET
 (RAMP "H")
 (SHEET 14 OF 20)
 STATE JOB NO. 090321081 SHEET NO. R080

OKLAHOMA COUNTY

3/4/2024 2:40:19 PM
 H:\PROJECTS\2789_CrossRoads_Phase 4\Roadway\Drawings\0903208-Phase 4_EC_H_Ramp_H_3.dgn

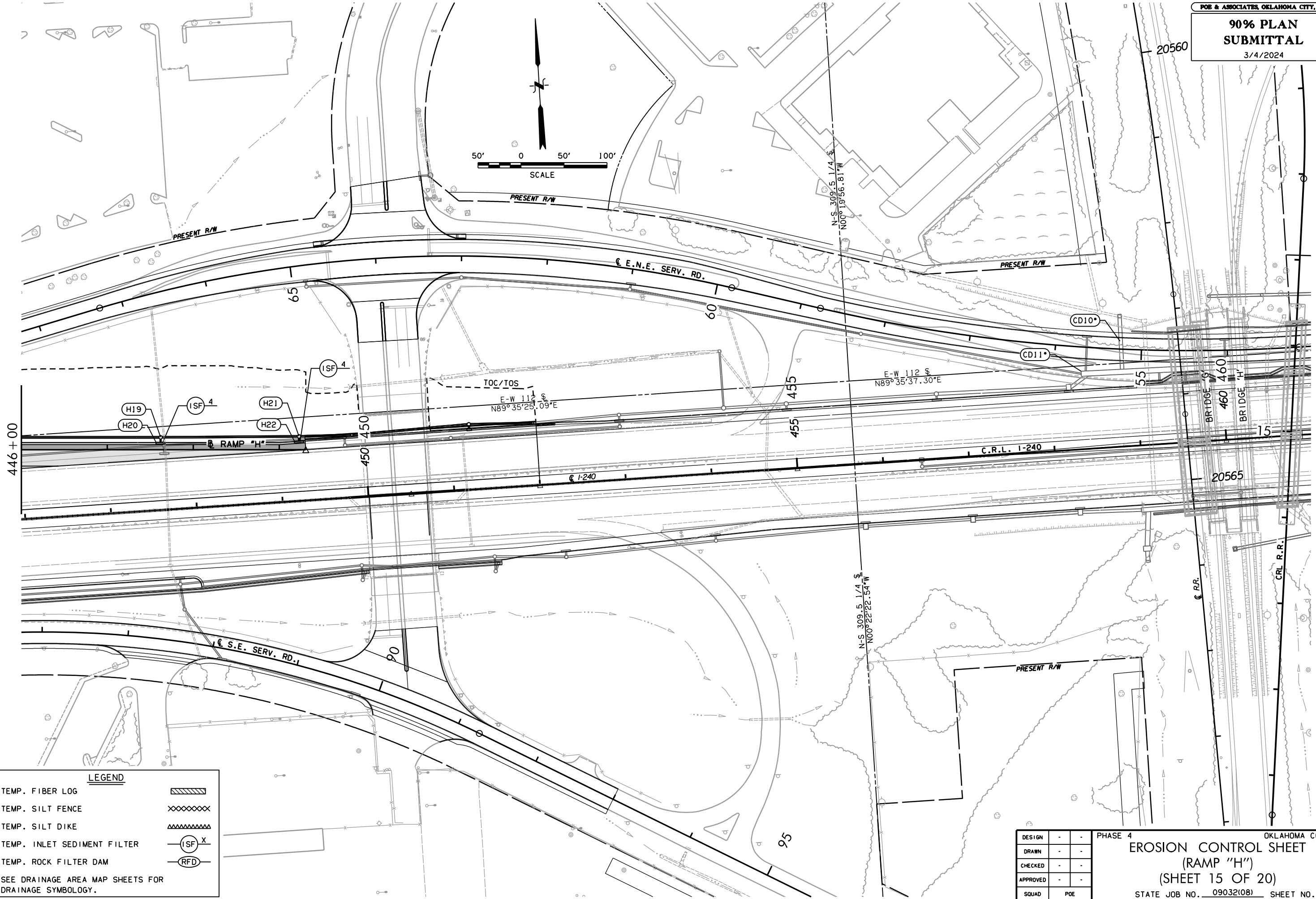
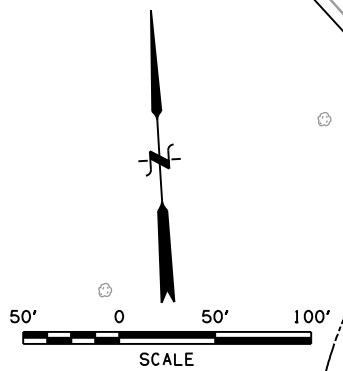

3/4/2024 2:40:22 PM
 H:\PROJECTS\2789_CrossRoads_Phase 4\Roadway\Drawings\0903208-Phase 4_EC_IS_Ramp_H_4.dgn

LEGEND	
TEMP. FIBER LOG	
TEMP. SILT FENCE	
TEMP. SILT DIKE	
TEMP. INLET SEDIMENT FILTER	
TEMP. ROCK FILTER DAM	
SEE DRAINAGE AREA MAP SHEETS FOR DRAINAGE SYMBOLOLOGY.	

DESIGN	-	-
DRAWN	-	-
CHECKED	-	-
APPROVED	-	-
SQUAD	POE	

PHASE 4
EROSION CONTROL SHEET
 (RAMP "H")
 (SHEET 15 OF 20)
 OKLAHOMA COUNTY
 STATE JOB NO. 090321081 SHEET NO. R081

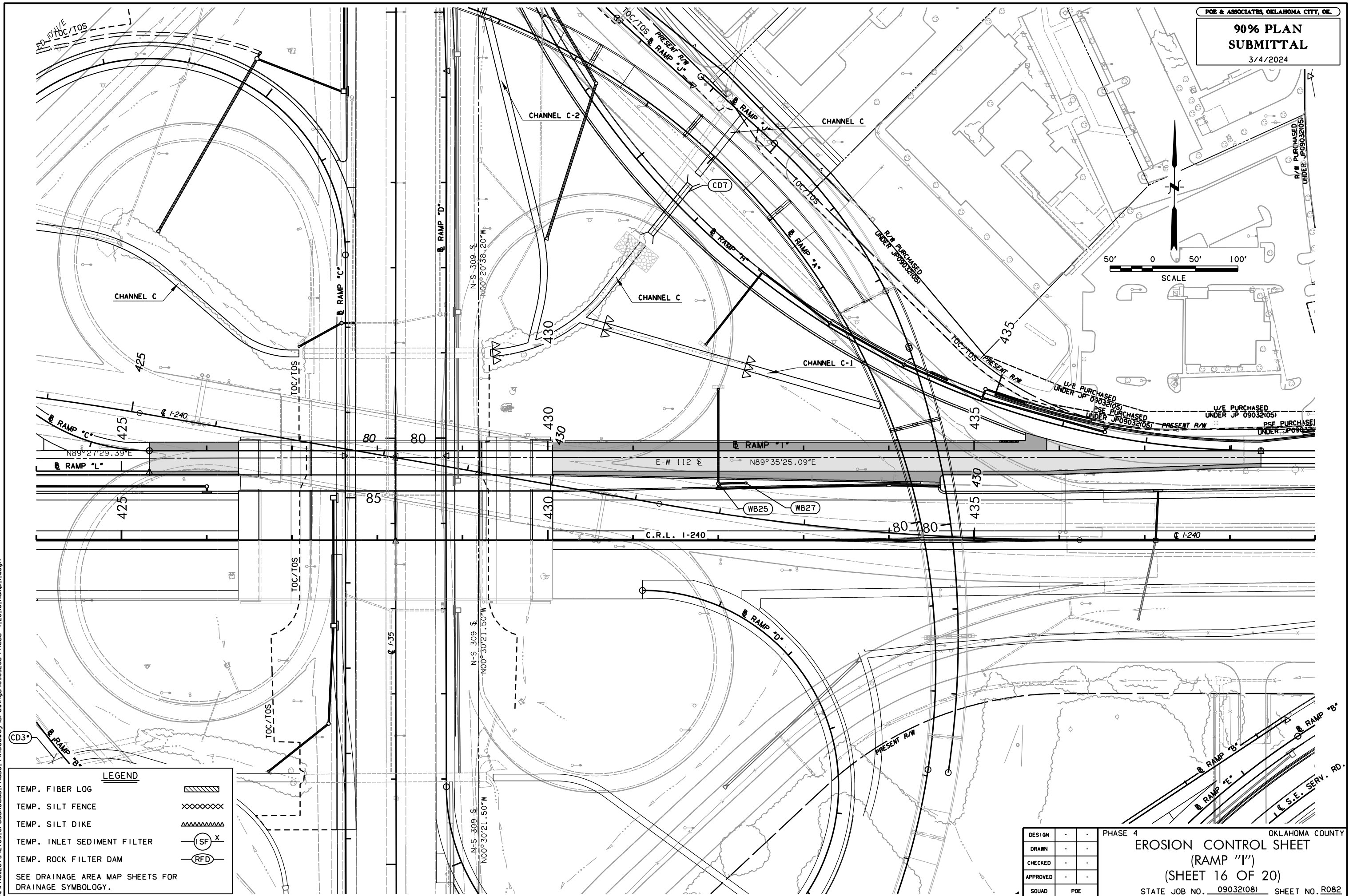
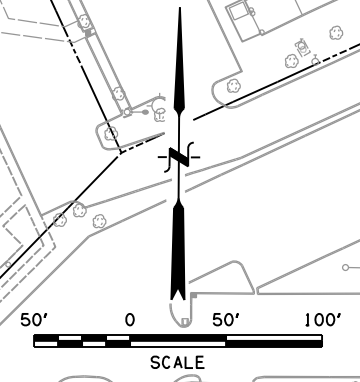

3/4/2024 2:40:26 PM
H:\PROJECTS\2789_CrossRoads_Phase 4\Roadway\Drawings\0903208-Phase 4_EC_16_Ramp_I.dgn

LEGEND

TEMP. FIBER LOG	
TEMP. SILT FENCE	
TEMP. SILT DIKE	
TEMP. INLET SEDIMENT FILTER	
TEMP. ROCK FILTER DAM	
SEE DRAINAGE AREA MAP SHEETS FOR DRAINAGE SYMBOLOLOGY.	

DESIGN	-	-
DRAWN	-	-
CHECKED	-	-
APPROVED	-	-
SQUAD	POE	

PHASE 4
OKLAHOMA COUNTY
EROSION CONTROL SHEET
(RAMP "I")
(SHEET 16 OF 20)
STATE JOB NO. 090321081 SHEET NO. R082

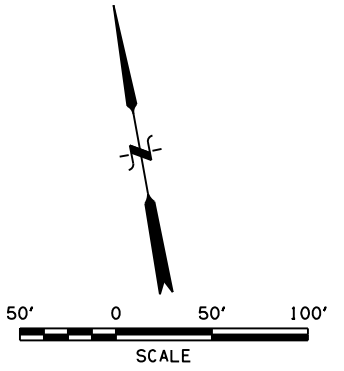

3/4/2024 2:40:29 PM H:\PROJECTS\2789_CrossRoads\Phase 4\Roadway\Drawings\0903208-Phase 4_EC.IT_Ramp.L.dgn

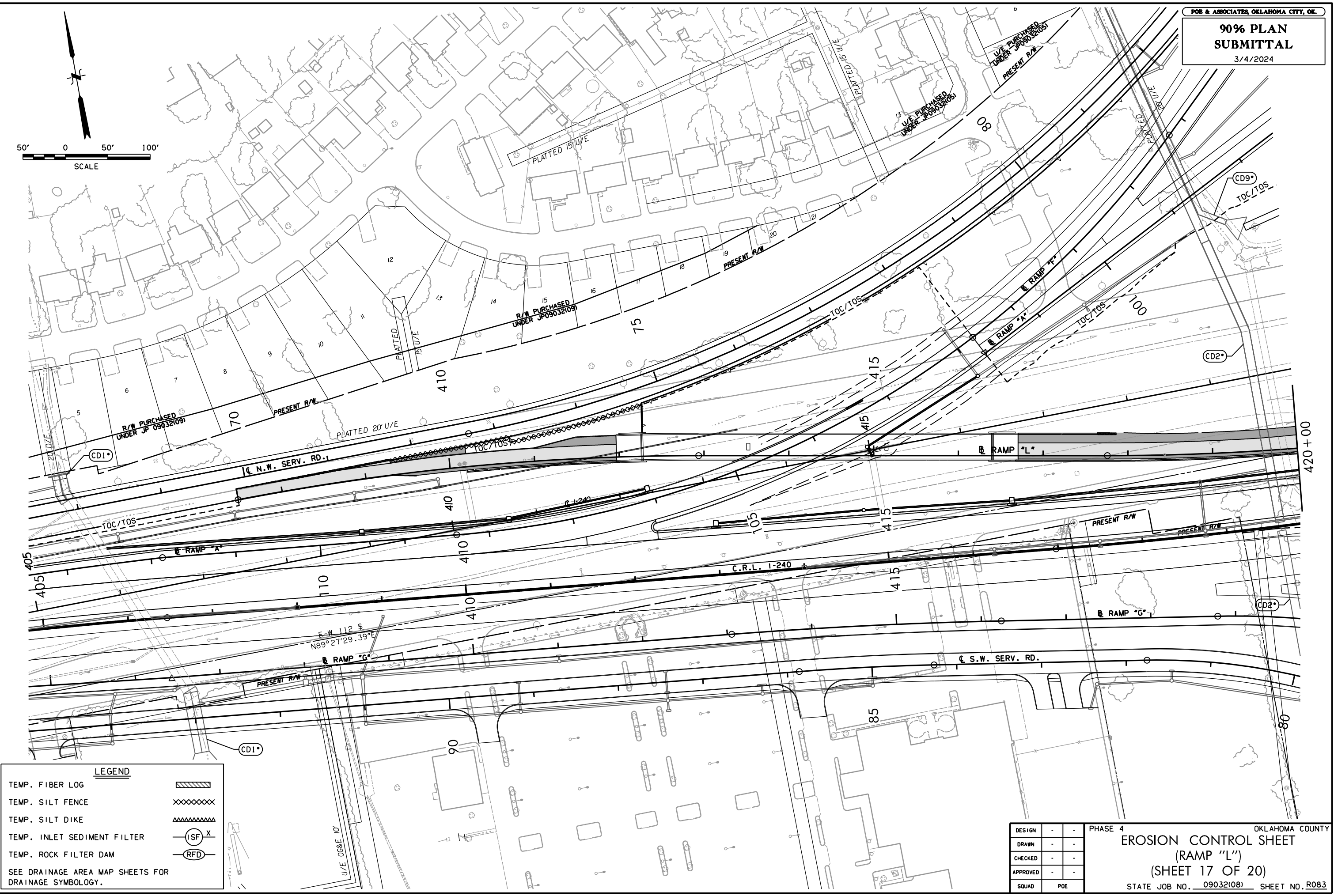

LEGEND

TEMP. FIBER LOG	
TEMP. SILT FENCE	
TEMP. SILT DIKE	
TEMP. INLET SEDIMENT FILTER	
TEMP. ROCK FILTER DAM	

SEE DRAINAGE AREA MAP SHEETS FOR DRAINAGE SYMBOLOLOGY.

DESIGN	-	-	PHASE 4	OKLAHOMA COUNTY
DRAWN	-	-	EROSION CONTROL SHEET (RAMP "L") (SHEET 17 OF 20) STATE JOB NO. 09032108 SHEET NO. R083	
CHECKED	-	-		
APPROVED	-	-		
SQUAD	POE			

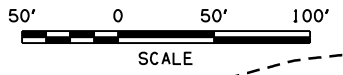
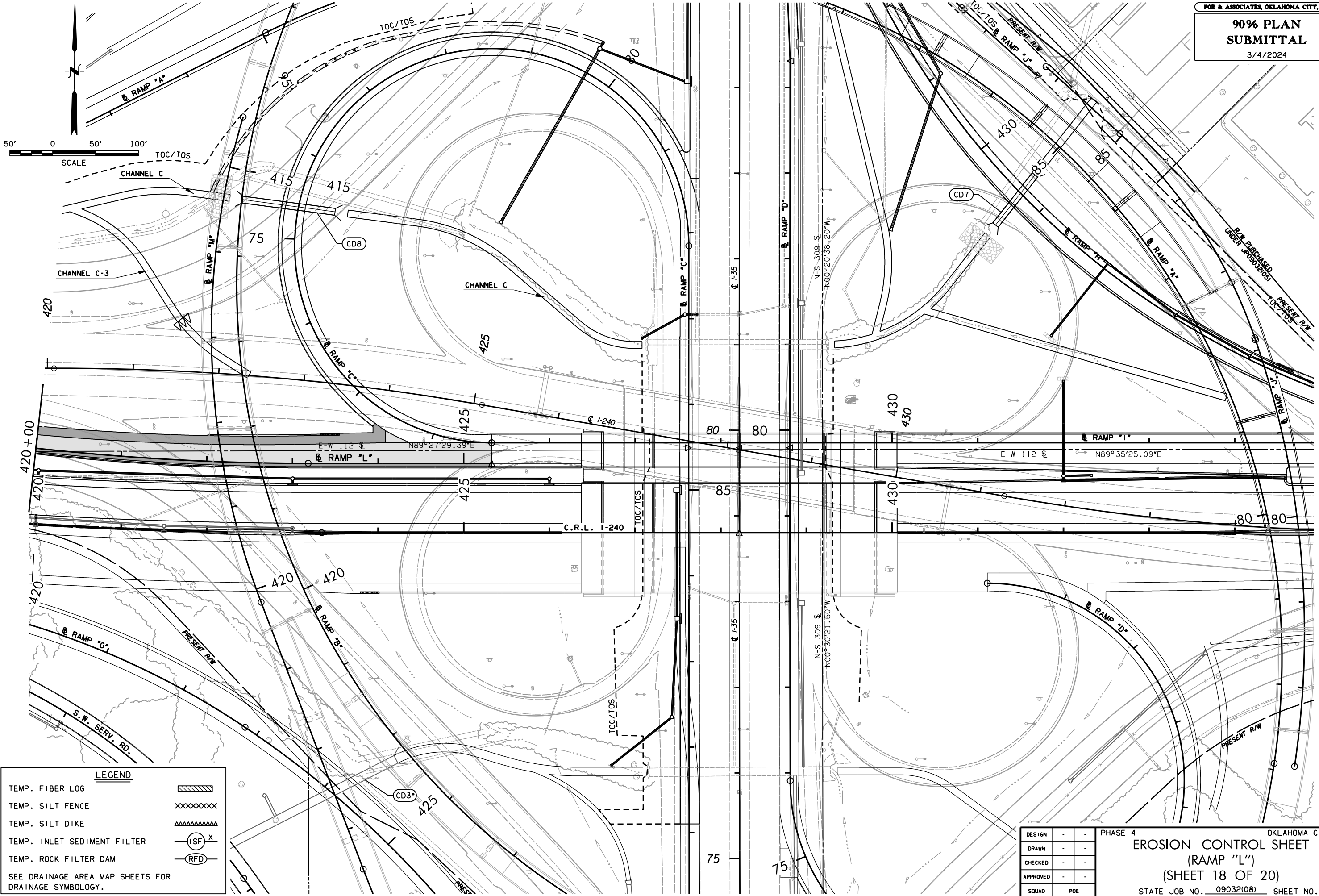

LEGEND

TEMP. FIBER LOG	
TEMP. SILT FENCE	
TEMP. SILT DIKE	
TEMP. INLET SEDIMENT FILTER	
TEMP. ROCK FILTER DAM	
SEE DRAINAGE AREA MAP SHEETS FOR DRAINAGE SYMBOLOLOGY.	

DESIGN	-	-	PHASE 4
DRAWN	-	-	
CHECKED	-	-	
APPROVED	-	-	
SQUAD	POE		

OKLAHOMA COUNTY
EROSION CONTROL SHEET
 (RAMP "L")
 (SHEET 18 OF 20)
 STATE JOB NO. 090321081 SHEET NO. R084

3/4/2024 2:40:32 PM
 H:\PROJECTS\2789_CrossRoads_Phase 4\Roadway\Drawings\0903208-Phase 4_EC_IB_Ramp_L_2.dgn

R/W PURCHASED UNDER
JP090321051
PRESENT R/W

R/W PURCHASED
UNDER JP 090321051

U/E PURCHASED
UNDER JP 090321051

R/W PURCHASED
UNDER JP 090321051

R/W PURCHASED
UNDER JP090321051

R/W PURCHASED
UNDER JP090321051

R/W PURCHASED
UNDER JP 090321051

LEGEND

TEMP. FIBER LOG	
TEMP. SILT FENCE	
TEMP. SILT DIKE	
TEMP. INLET SEDIMENT FILTER	
TEMP. ROCK FILTER DAM	

SEE DRAINAGE AREA MAP SHEETS FOR DRAINAGE SYMBOLOLOGY.

DESIGN	-	-	PHASE 4
DRAWN	-	-	EROSION CONTROL SHEET (N.N.E. SERV. RD.) (SHEET 19 OF 20) STATE JOB NO. 090321081 SHEET NO. R085
CHECKED	-	-	
APPROVED	-	-	
SQUAD	POE		

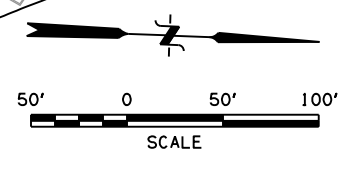

3/4/2024 2:40:34 PM H:\PROJECTS\2789_CrossRoads_Phase 4\Roadway\Drawings\0903208-Phase 4_EC_19_NNE_SERV_RD_1.dgn

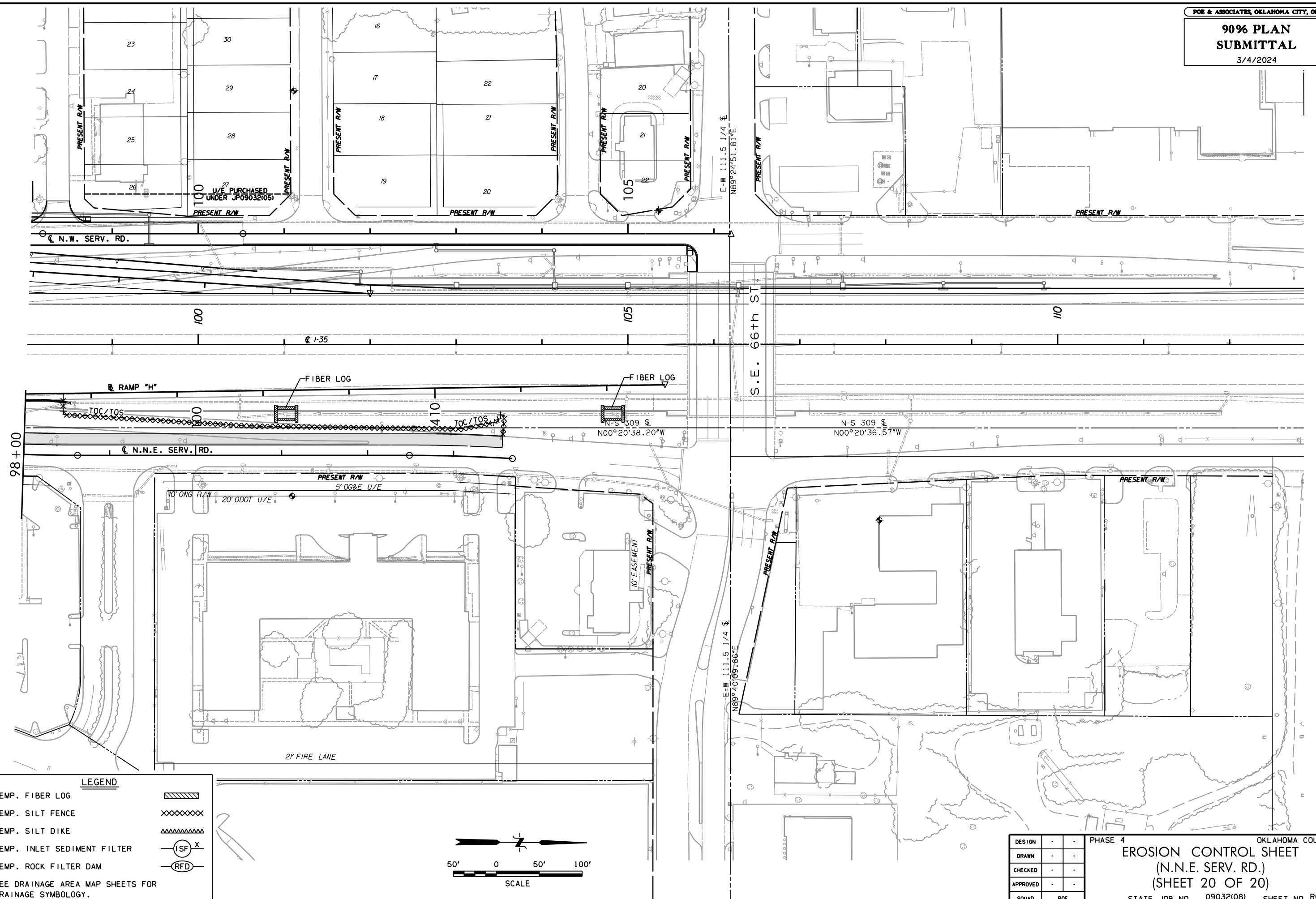

3/4/2024 2:40:36 PM H:\PROJECTS\2789_CrossRoads_Phase 4\Roadway\Drawings\0903208-Phase 4_EC-20_NNE_SERV_RD_2.dgn

LEGEND	
TEMP. FIBER LOG	
TEMP. SILT FENCE	
TEMP. SILT DIKE	
TEMP. INLET SEDIMENT FILTER	
TEMP. ROCK FILTER DAM	
SEE DRAINAGE AREA MAP SHEETS FOR DRAINAGE SYMBOLOLOGY.	

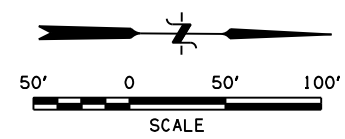

DESIGN	-	-
DRAWN	-	-
CHECKED	-	-
APPROVED	-	-
SQUAD	POE	

PHASE 4
EROSION CONTROL SHEET
 (N.N.E. SERV. RD.)
 (SHEET 20 OF 20)
 STATE JOB NO. 090321081 SHEET NO. R086

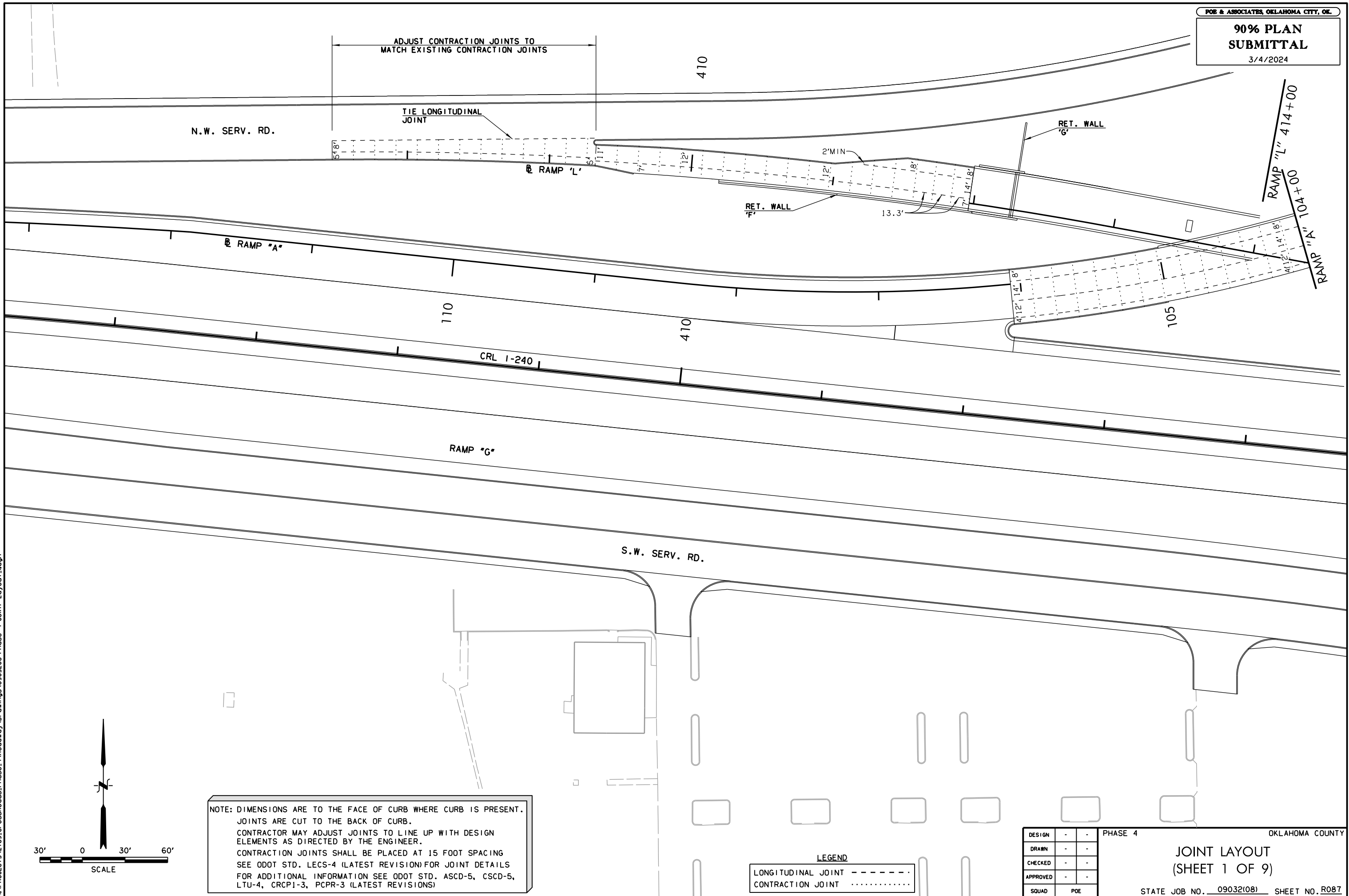

3/4/2024 2:40:38 PM H:\PROJECTS\2789_CrossRoads_Phase 4\Roadway\Drawings\0903208-Phase 4 Joint Layout.dgn

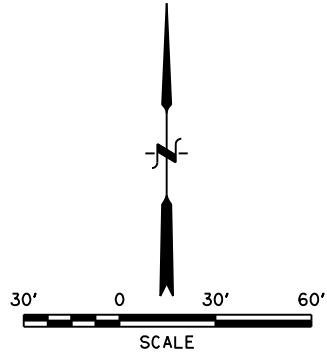

NOTE: DIMENSIONS ARE TO THE FACE OF CURB WHERE CURB IS PRESENT.
 JOINTS ARE CUT TO THE BACK OF CURB.
 CONTRACTOR MAY ADJUST JOINTS TO LINE UP WITH DESIGN ELEMENTS AS DIRECTED BY THE ENGINEER.
 CONTRACTION JOINTS SHALL BE PLACED AT 15 FOOT SPACING
 SEE ODOT STD. LECS-4 (LATEST REVISION) FOR JOINT DETAILS
 FOR ADDITIONAL INFORMATION SEE ODOT STD. ASCD-5, CSCD-5, LTU-4, CRCP1-3, PCPR-3 (LATEST REVISIONS)

LEGEND

LONGITUDINAL JOINT	- - - - -
CONTRACTION JOINT

DESIGN	-	-
DRAWN	-	-
CHECKED	-	-
APPROVED	-	-
SQUAD	POE	

PHASE 4
 OKLAHOMA COUNTY
JOINT LAYOUT
 (SHEET 1 OF 9)
 STATE JOB NO. 09032108 SHEET NO. R087

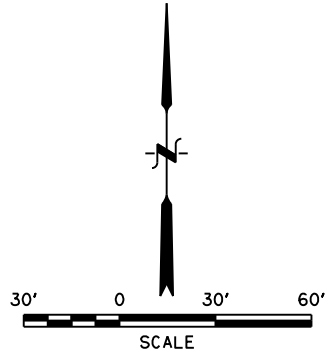
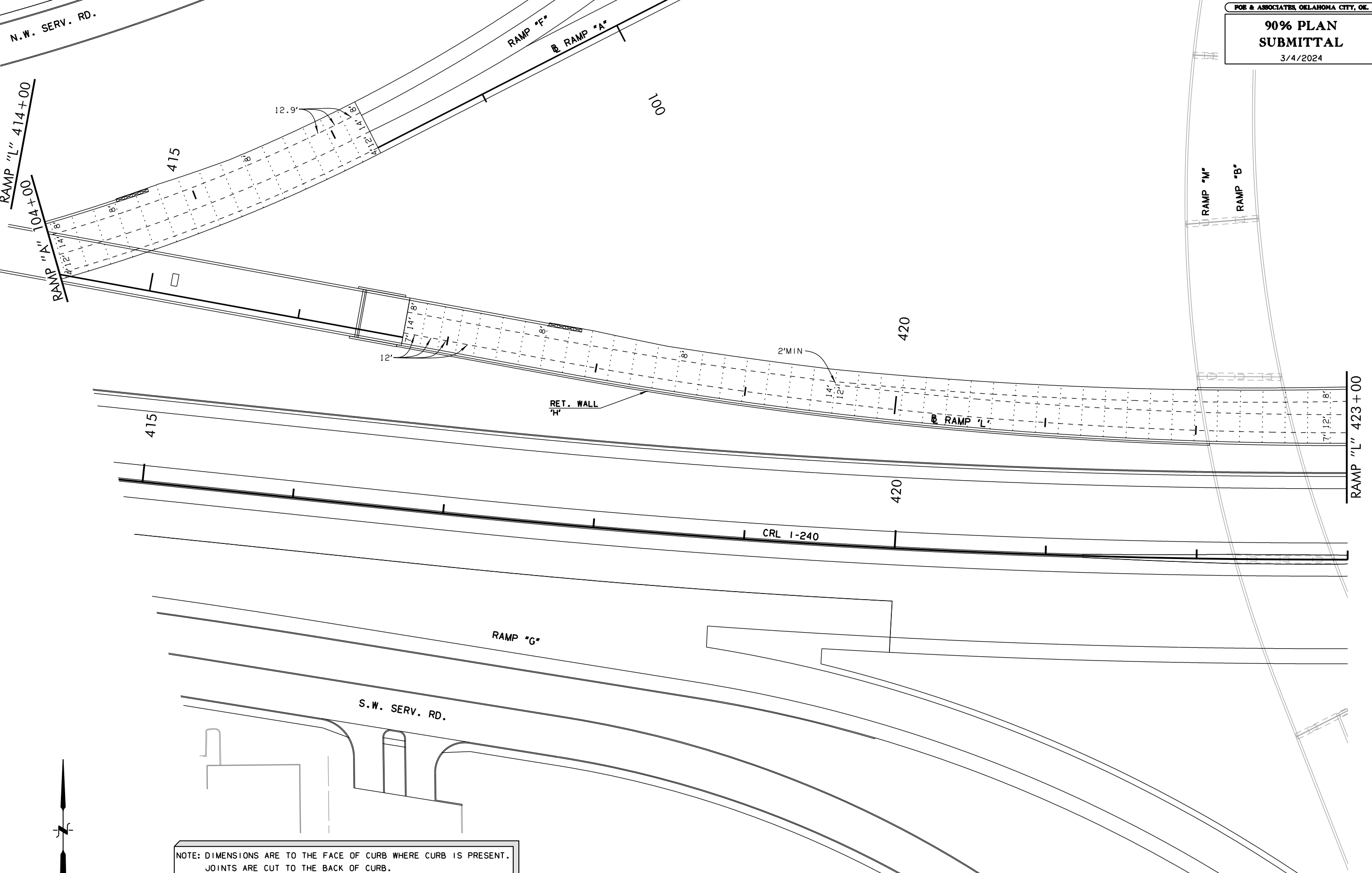

NOTE: DIMENSIONS ARE TO THE FACE OF CURB WHERE CURB IS PRESENT.
 JOINTS ARE CUT TO THE BACK OF CURB.
 CONTRACTOR MAY ADJUST JOINTS TO LINE UP WITH DESIGN ELEMENTS AS DIRECTED BY THE ENGINEER.
 CONTRACTION JOINTS SHALL BE PLACED AT 15 FOOT SPACING
 SEE ODOT STD. LECS-4 (LATEST REVISION) FOR JOINT DETAILS
 FOR ADDITIONAL INFORMATION SEE ODOT STD. ASCD-5, CSCD-5, LTU-4, CRCP1-3, PCPR-3 (LATEST REVISIONS)

LEGEND

LONGITUDINAL JOINT	- - - - -
CONTRACTION JOINT

DESIGN	-	-
DRAWN	-	-
CHECKED	-	-
APPROVED	-	-
SQUAD	POE	

PHASE 4
 OKLAHOMA COUNTY
JOINT LAYOUT
(SHEET 2 OF 9)
 STATE JOB NO. 09032108 SHEET NO. R088

3/4/2024 2:40:38 PM
 H:\PROJECTS\2789_CrossRoads_Phase 4\Roadway\Drawings\0903208-Phase 4 Joint Layout.2.dgn

RAMP "C" 83+00
(SEE SHEET 6 OF 9)

RAMP "C" 74+00
(SEE SHEET 6 OF 9)

RAMP "L" 423+00

RAMP "I" 432+00

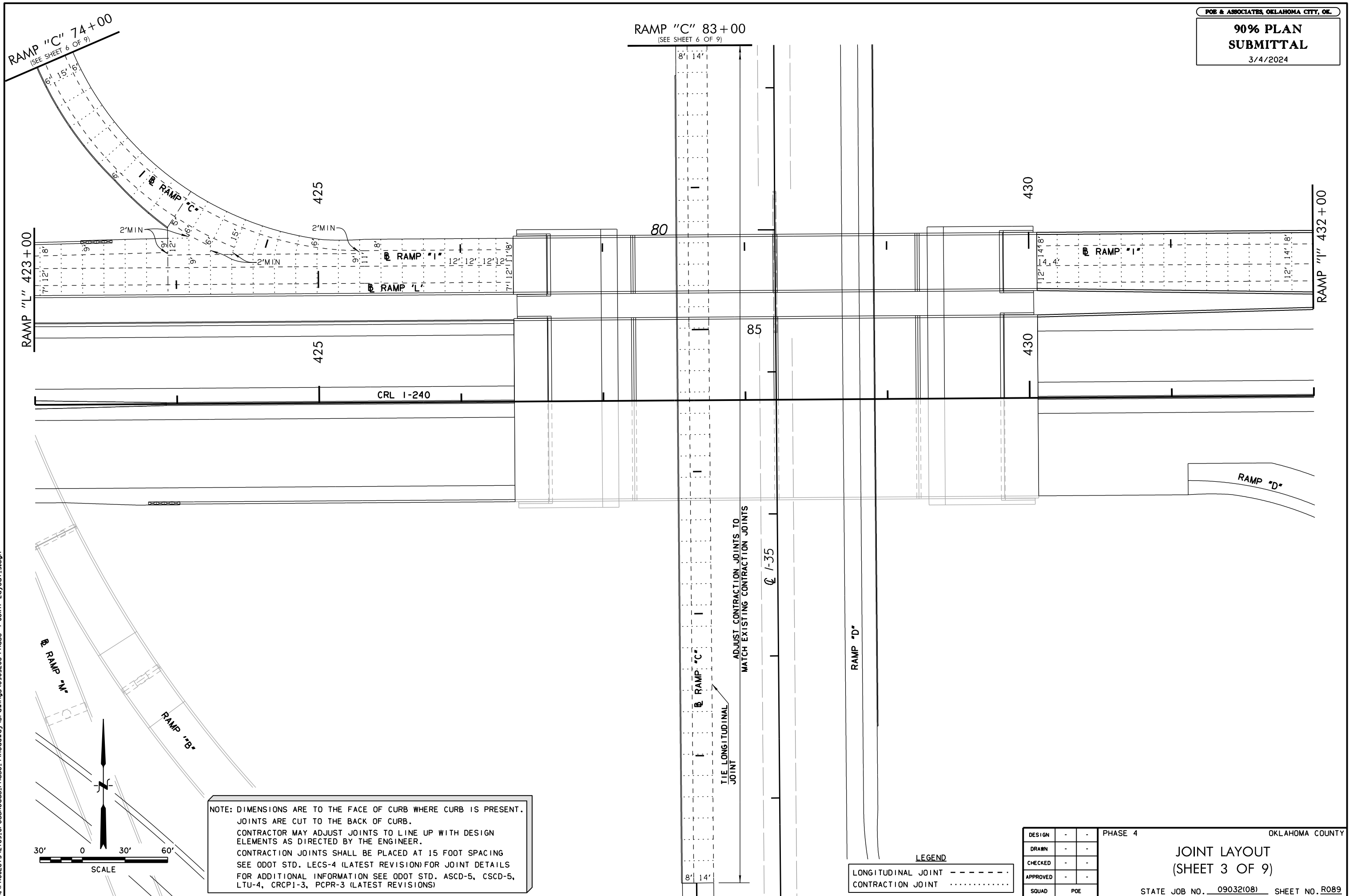

3/4/2024 2:40:39 PM
H:\PROJECTS\2789_CrossRoads_Phase 4\Roadway\Drawings\0903208-Phase 4 Joint Layout_3.dgn

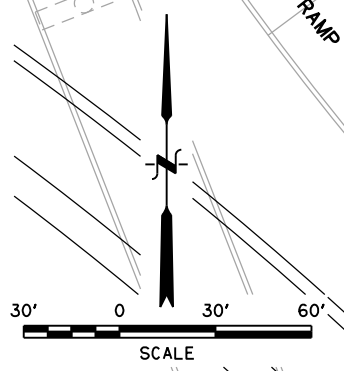

NOTE: DIMENSIONS ARE TO THE FACE OF CURB WHERE CURB IS PRESENT.
 JOINTS ARE CUT TO THE BACK OF CURB.
 CONTRACTOR MAY ADJUST JOINTS TO LINE UP WITH DESIGN ELEMENTS AS DIRECTED BY THE ENGINEER.
 CONTRACTION JOINTS SHALL BE PLACED AT 15 FOOT SPACING
 SEE ODOT STD. LECS-4 (LATEST REVISION) FOR JOINT DETAILS
 FOR ADDITIONAL INFORMATION SEE ODOT STD. ASCD-5, CSCD-5,
 LTU-4, CRCP1-3, PCPR-3 (LATEST REVISIONS)

LEGEND

LONGITUDINAL JOINT	-----
CONTRACTION JOINT

DESIGN	-	-	PHASE 4	OKLAHOMA COUNTY
DRAWN	-	-	JOINT LAYOUT (SHEET 3 OF 9) STATE JOB NO. 09032108 SHEET NO. R089	
CHECKED	-	-		
APPROVED	-	-		
SQUAD	-	-		

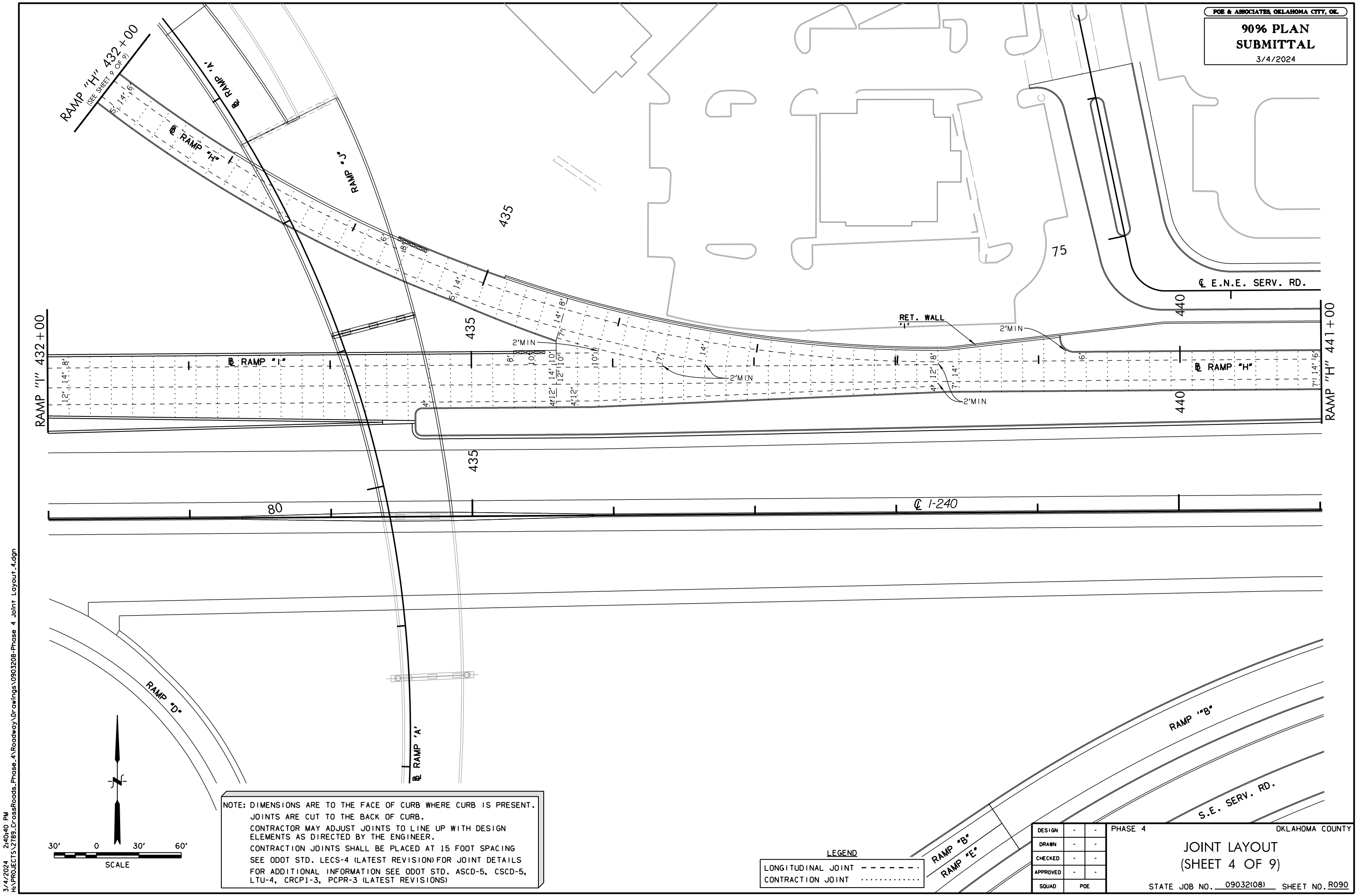

NOTE: DIMENSIONS ARE TO THE FACE OF CURB WHERE CURB IS PRESENT.
 JOINTS ARE CUT TO THE BACK OF CURB.
 CONTRACTOR MAY ADJUST JOINTS TO LINE UP WITH DESIGN ELEMENTS AS DIRECTED BY THE ENGINEER.
 CONTRACTION JOINTS SHALL BE PLACED AT 15 FOOT SPACING
 SEE ODOT STD. LECS-4 (LATEST REVISION) FOR JOINT DETAILS
 FOR ADDITIONAL INFORMATION SEE ODOT STD. ASCD-5, CSCD-5, LTU-4, CRCP1-3, PCPR-3 (LATEST REVISIONS)

LEGEND

LONGITUDINAL JOINT	---
CONTRACTION JOINT

DESIGN	-	-
DRAWN	-	-
CHECKED	-	-
APPROVED	-	-
SQUAD	POE	

PHASE 4
 OKLAHOMA COUNTY
JOINT LAYOUT
 (SHEET 4 OF 9)
 STATE JOB NO. 09032108 SHEET NO. R090

3/4/2024 2:40:40 PM
 H:\PROJECTS\2789_CrossRoads_Phase 4\Roadway\Drawings\0903208-Phase 4 Joint Layout_4.dgn

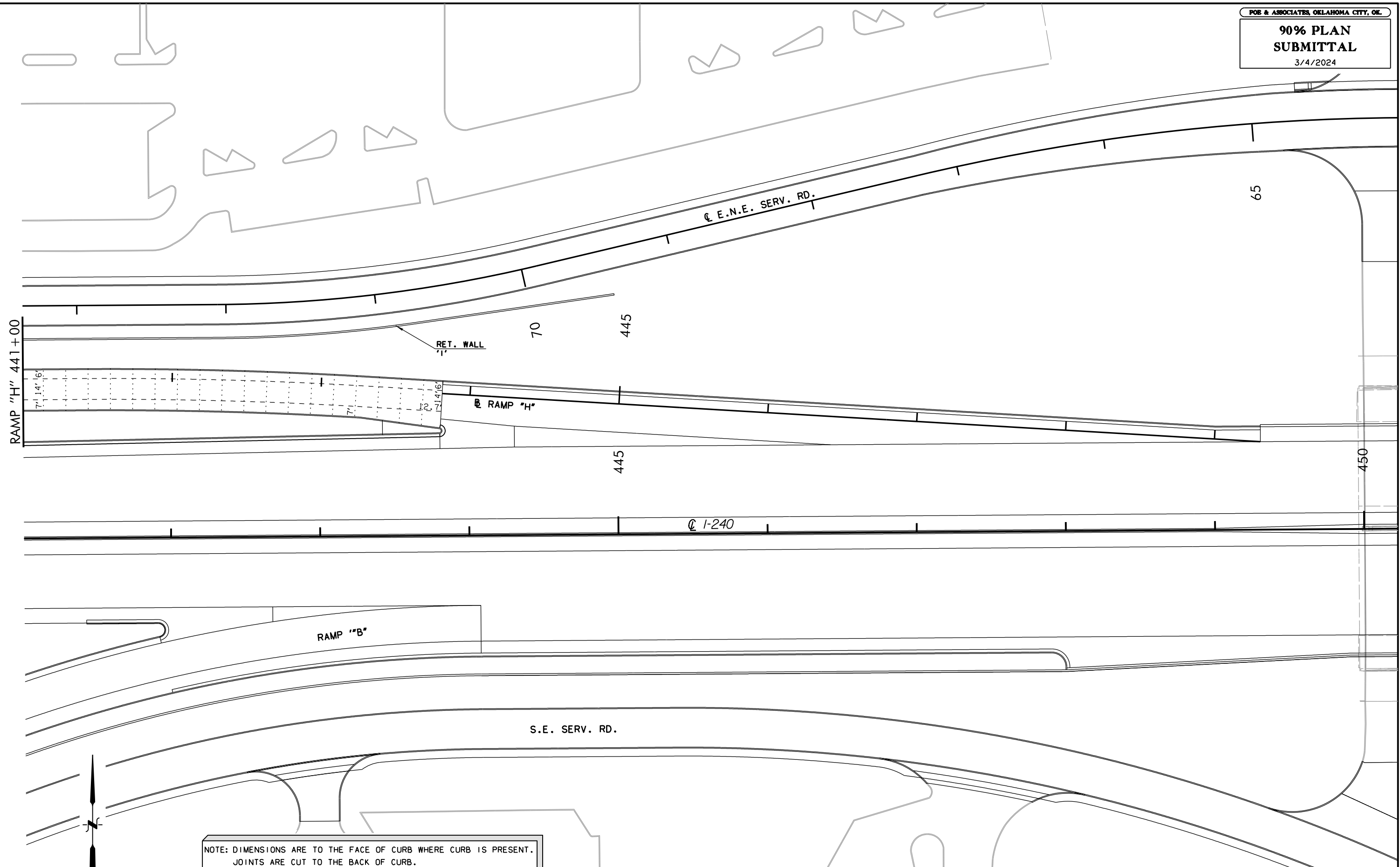

NOTE: DIMENSIONS ARE TO THE FACE OF CURB WHERE CURB IS PRESENT.
 JOINTS ARE CUT TO THE BACK OF CURB.
 CONTRACTOR MAY ADJUST JOINTS TO LINE UP WITH DESIGN ELEMENTS AS DIRECTED BY THE ENGINEER.
 CONTRACTION JOINTS SHALL BE PLACED AT 15 FOOT SPACING
 SEE ODOT STD. LECS-4 (LATEST REVISION) FOR JOINT DETAILS
 FOR ADDITIONAL INFORMATION SEE ODOT STD. ASCD-5, CSCD-5, LTU-4, CRCP1-3, PCPR-3 (LATEST REVISIONS)

LEGEND

LONGITUDINAL JOINT	-----
CONTRACTION JOINT

DESIGN	-	-
DRAWN	-	-
CHECKED	-	-
APPROVED	-	-
SQUAD	POE	

PHASE 4
 OKLAHOMA COUNTY
**JOINT LAYOUT
 (SHEET 5 OF 9)**
 STATE JOB NO. 09032108 SHEET NO. R091

3/4/2024 2:40:41 PM H:\PROJECTS\2789_CrossRoads_Phase 4\Roadway\Drawings\0903208-Phase 4 Joint Layout_5.dgn

CL I-35 86+00
 (SEE SHEET 6 OF 9)

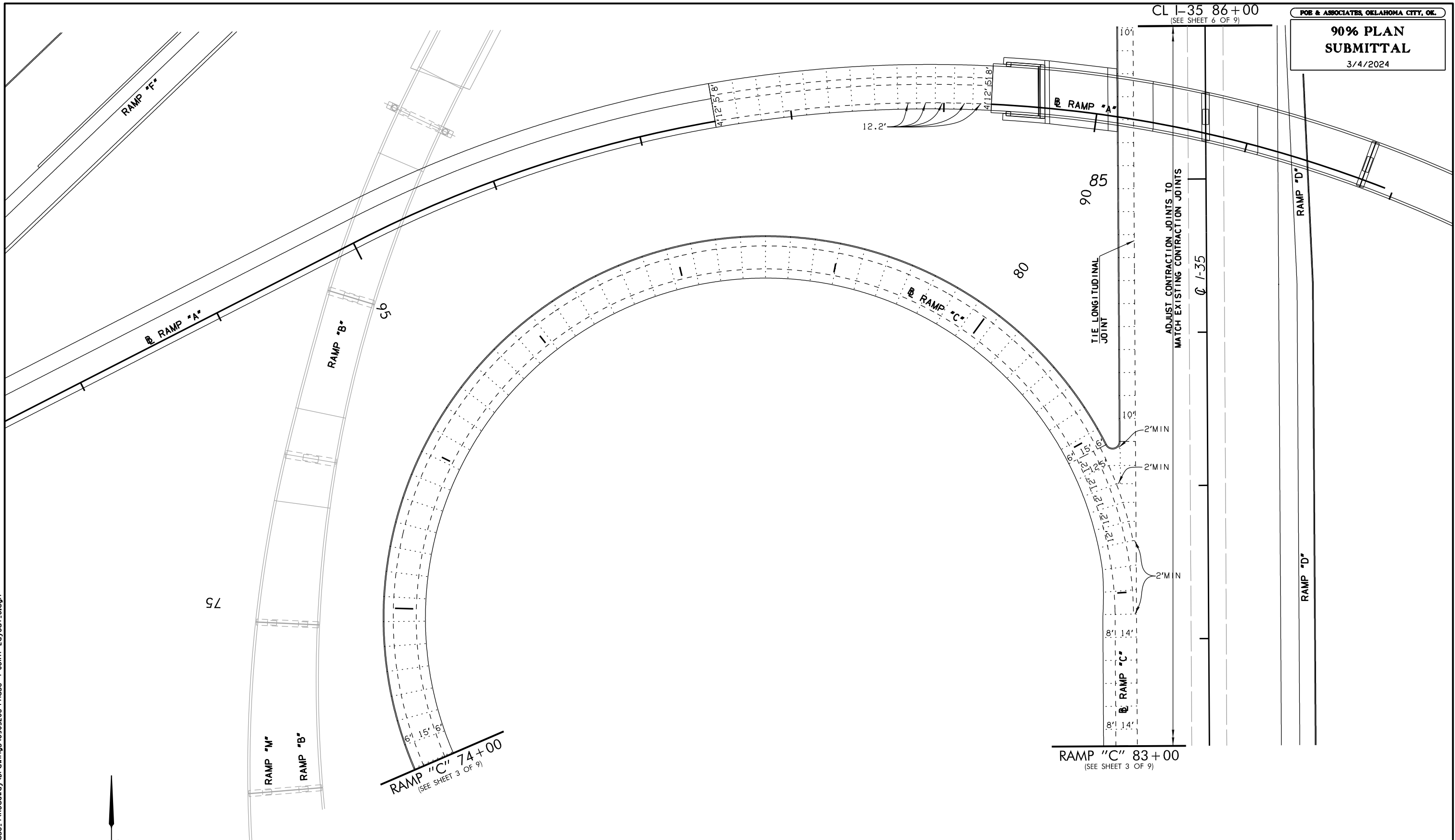

TIE LONGITUDINAL JOINT
 ADJUST CONTRACTION JOINTS TO
 MATCH EXISTING CONTRACTION JOINTS

NOTE: DIMENSIONS ARE TO THE FACE OF CURB WHERE CURB IS PRESENT.
 JOINTS ARE CUT TO THE BACK OF CURB.
 CONTRACTOR MAY ADJUST JOINTS TO LINE UP WITH DESIGN ELEMENTS AS DIRECTED BY THE ENGINEER.
 CONTRACTION JOINTS SHALL BE PLACED AT 15 FOOT SPACING
 SEE ODOT STD. LECS-4 (LATEST REVISION) FOR JOINT DETAILS
 FOR ADDITIONAL INFORMATION SEE ODOT STD. ASCD-5, CSCD-5, LTU-4, CRCP1-3, PCPR-3 (LATEST REVISIONS)

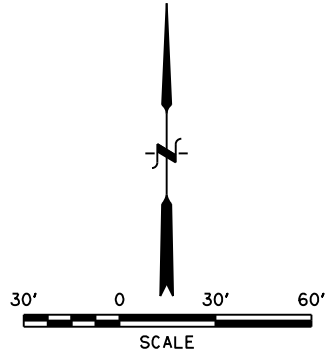

LEGEND

LONGITUDINAL JOINT	----
CONTRACTION JOINT

DESIGN	-	-
DRAWN	-	-
CHECKED	-	-
APPROVED	-	-
SQUAD	POE	

PHASE 4
 OKLAHOMA COUNTY
JOINT LAYOUT
 (SHEET 6 OF 9)
 STATE JOB NO. 090321081 SHEET NO. R092

3/4/2024 2:40:42 PM
 H:\PROJECTS\2789_CrossRoads_Phase 4\Roadway\Drawings\0903208-Phase 4 Joint Layout.6.dgn

ADJUST CONTRACTION JOINTS TO
MATCH EXISTING CONTRACTION JOINTS

TIE LONGITUDINAL
JOINT

CL N.N.E. SERV. RD.

410

90

415

CL RAMP "H"

TIE LONGITUDINAL
JOINT

95

ADJUST CONTRACTION JOINTS TO
MATCH EXISTING CONTRACTION JOINTS

CL I-35

100

ADJUST CONTRACTION JOINTS TO
MATCH EXISTING CONTRACTION JOINTS

12.6'

611.1'

CL I-35 95+00

RAMP "B"

TIE LONGITUDINAL
JOINT

N.W. SERV. RD.

RAMP "H" 418+00

NOTE: DIMENSIONS ARE TO THE FACE OF CURB WHERE CURB IS PRESENT.
JOINTS ARE CUT TO THE BACK OF CURB.
CONTRACTOR MAY ADJUST JOINTS TO LINE UP WITH DESIGN
ELEMENTS AS DIRECTED BY THE ENGINEER.
CONTRACTION JOINTS SHALL BE PLACED AT 15 FOOT SPACING
SEE ODOT STD. LECS-4 (LATEST REVISION) FOR JOINT DETAILS
FOR ADDITIONAL INFORMATION SEE ODOT STD. ASCD-5, CSCD-5,
LTU-4, CRCP1-3, PCPR-3 (LATEST REVISIONS)

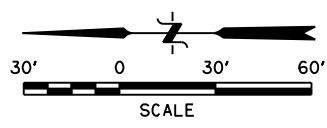

LEGEND

LONGITUDINAL JOINT	---
CONTRACTION JOINT

DESIGN	-	-
DRAWN	-	-
CHECKED	-	-
APPROVED	-	-
SQUAD	POE	

PHASE 4
OKLAHOMA COUNTY
JOINT LAYOUT
(SHEET 7 OF 9)
STATE JOB NO. 090321081 SHEET NO. R093

3/4/2024 2:40:43 PM H:\PROJECTS\2789_CrossRoads_Phase 4\Roadway\Drawings\0903208-Phase 4 Joint Layout_7.dgn

3/4/2024 2:40:43 PM
H:\PROJECTS\2789_CrossRoads_Phase 4\Roadway\Drawings\0903208-Phase 4 Joint Layout.dgn

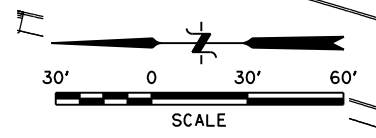
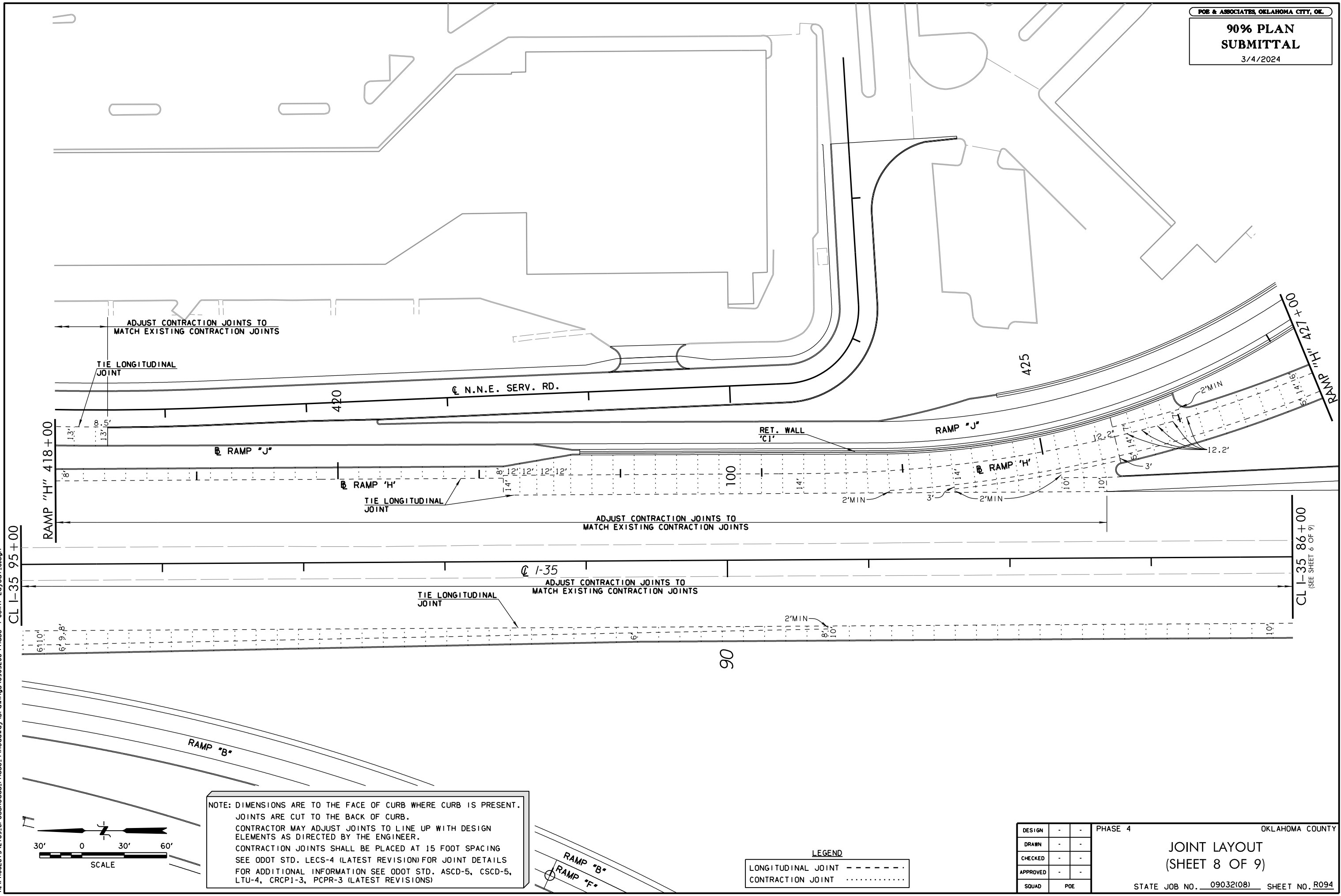

NOTE: DIMENSIONS ARE TO THE FACE OF CURB WHERE CURB IS PRESENT.
 JOINTS ARE CUT TO THE BACK OF CURB.
 CONTRACTOR MAY ADJUST JOINTS TO LINE UP WITH DESIGN ELEMENTS AS DIRECTED BY THE ENGINEER.
 CONTRACTION JOINTS SHALL BE PLACED AT 15 FOOT SPACING
 SEE ODOT STD. LECS-4 (LATEST REVISION) FOR JOINT DETAILS
 FOR ADDITIONAL INFORMATION SEE ODOT STD. ASCD-5, CSCD-5, LTU-4, CRCP1-3, PCPR-3 (LATEST REVISIONS)

LEGEND

LONGITUDINAL JOINT	---
CONTRACTION JOINT

DESIGN	-	-
DRAWN	-	-
CHECKED	-	-
APPROVED	-	-
SQUAD	POE	

PHASE 4
 OKLAHOMA COUNTY
JOINT LAYOUT
 (SHEET 8 OF 9)
 STATE JOB NO. 09032108 SHEET NO. R094

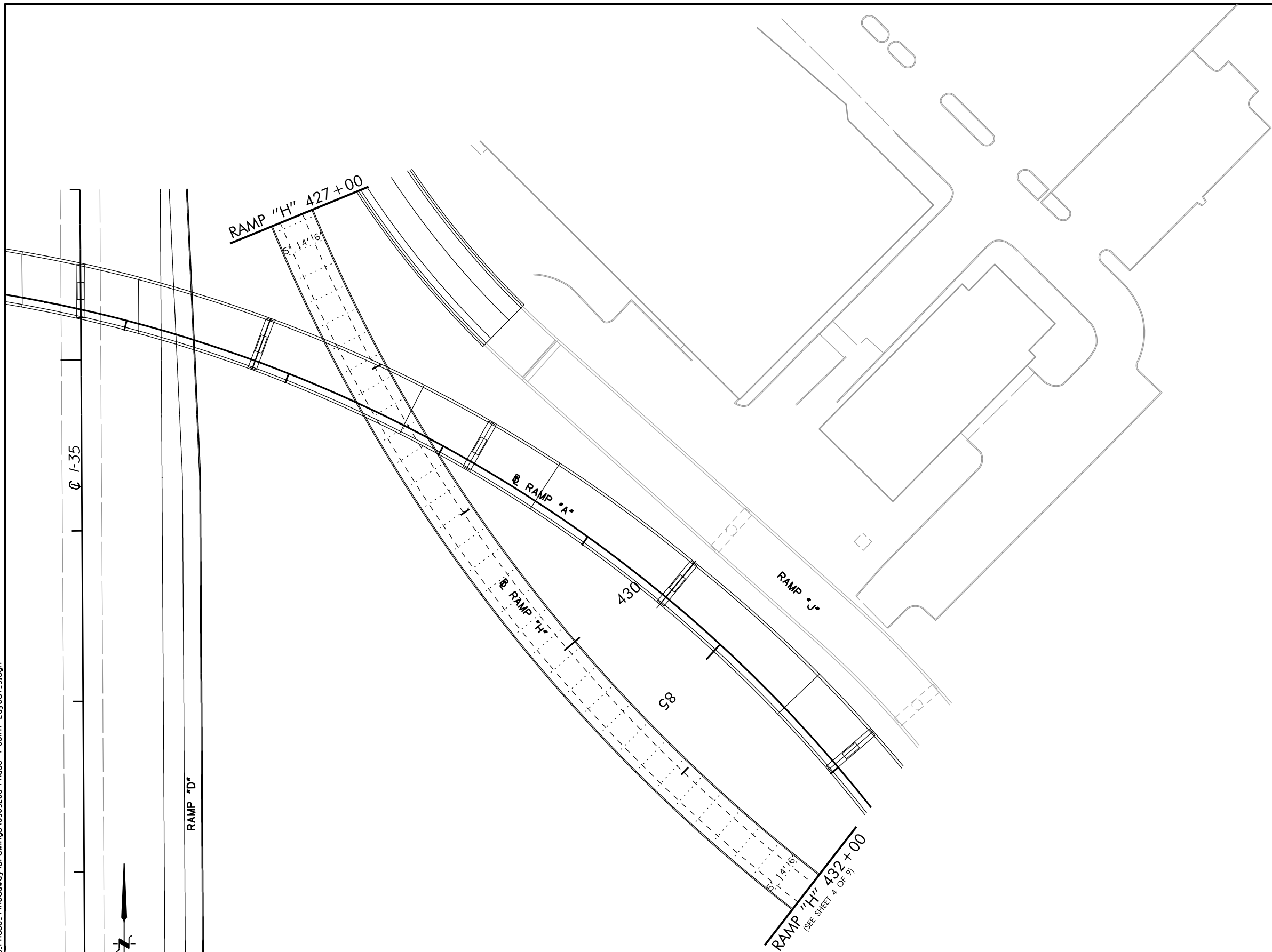

3/4/2024 2:40:44 PM
H:\PROJECTS\2789_CrossRoads_Phase 4\Roadway\Drawings\0903208-Phase 4 Joint Layout.9.dgn

NOTE: DIMENSIONS ARE TO THE FACE OF CURB WHERE CURB IS PRESENT.
 JOINTS ARE CUT TO THE BACK OF CURB.
 CONTRACTOR MAY ADJUST JOINTS TO LINE UP WITH DESIGN ELEMENTS AS DIRECTED BY THE ENGINEER.
 CONTRACTION JOINTS SHALL BE PLACED AT 15 FOOT SPACING
 SEE ODOT STD. LECS-4 (LATEST REVISION) FOR JOINT DETAILS
 FOR ADDITIONAL INFORMATION SEE ODOT STD. ASCD-5, CSCD-5, LTU-4, CRCP1-3, PCPR-3 (LATEST REVISIONS)

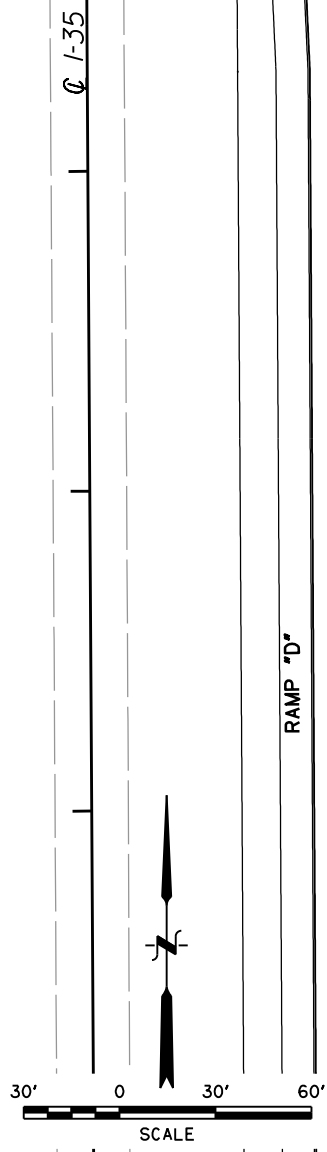

LEGEND

LONGITUDINAL JOINT	-----
CONTRACTION JOINT

DESIGN	-	-	PHASE 4	OKLAHOMA COUNTY
DRAWN	-	-	JOINT LAYOUT (SHEET 9 OF 9)	
CHECKED	-	-		
APPROVED	-	-		
SQUAD	POE		STATE JOB NO. 090321081	SHEET NO. R095

SEC. 27, T11N, R3W

BM*11
 0-55-1838

BM*10

REMOVE 28.63 L.F.
 OF CURB & GUTTER
 CONST. IN PREV. PHASE

REMOVE 479.81 L.F.
 OF CURB & GUTTER

REMOVE 192.18 L.F.
 OF CURB & GUTTER
 CONST. IN PREV. PHASE

SAWCUT 158.77 L.F.
 OF PAVEMENT

REMOVE
 LIGHTPOLE

REMOVE INLET
 & 18" RCP

REMOVE
 LIGHTPOLES

REMOVE
 LIGHTPOLE

P.I. Sta. 400+00.00 @ 1:240 BK.
 P.C. STA. 399+96.14 AHD.

STATION
 EQUATION

REMOVAL OF ASPH.
 PAVEMENT = 3,889.46 S.Y.

BM*20

BM*21

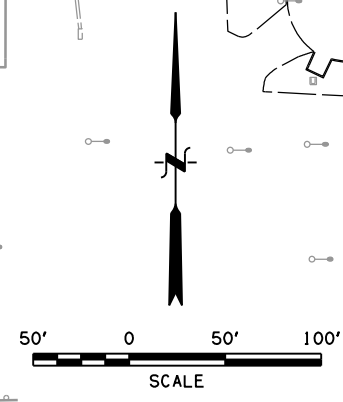

REMOVAL LEGEND

- PREVIOUS PHASE REMOVAL
- ASPHALT REMOVAL

REMOVAL TOTALS THIS SHEET

3889.46 S.Y. ASPHALT PAVEMENT
700.62 L.F. CONC. CURB & GUTTER
158.77 L.F. SAWCUT

NOTE:
 INTEGRAL CONC. CURB INCLUDED IN S.Y.
 QUANTITY OF P.C. CONC. PAVEMENT

DESIGN	-	-
DRAWN	-	-
CHECKED	-	-
APPROVED	-	-
SQUAD	POE	

PHASE 4
REMOVALS
 PHASE 4 CONSTRUCTION
 (SHEET 1 OF 6)
 STATE JOB NO. 090321081 SHEET NO. R096

SEC. 34, T11N, R3W

3/4/2024 2:40:45 PM
 H:\PROJECTS\2789_CrossRoads_Phase 4\Roadway\Drawings\0903208-Phase 4 Removals.dgn

SEC. 27, T11N, R3W

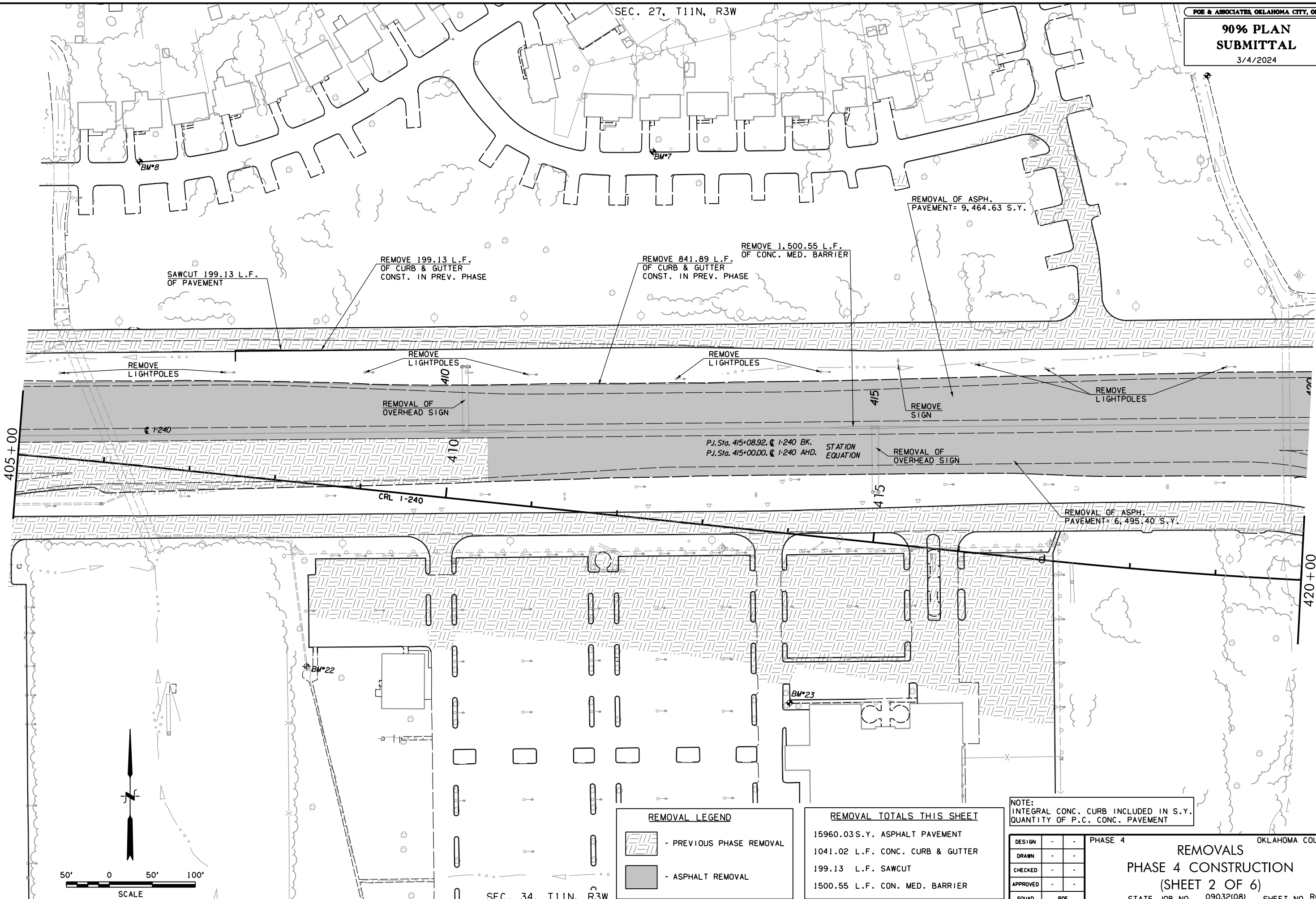

SAWCUT 199.13 L.F. OF PAVEMENT

REMOVE 199.13 L.F. OF CURB & GUTTER CONST. IN PREV. PHASE

REMOVE 841.89 L.F. OF CURB & GUTTER CONST. IN PREV. PHASE

REMOVE 1,500.55 L.F. OF CONC. MED. BARRIER

REMOVE 9,464.63 S.Y. ASPH. PAVEMENT

REMOVE LIGHTPOLES

REMOVE LIGHTPOLES

REMOVE LIGHTPOLES

REMOVE SIGN

REMOVE LIGHTPOLES

P.I. Sta. 415+08.92, C/L 1-240 BK.
 P.I. Sta. 415+00.00, C/L 1-240 AHD.
 STATION EQUATION

REMOVE OF OVERHEAD SIGN

REMOVE 6,495.40 S.Y. ASPH. PAVEMENT

3/4/2024 2:40:47 PM H:\PROJECTS\2789_CrossRoads_Phase 4\Roadway\Drawings\0903208-Phase 4 Removals.dgn

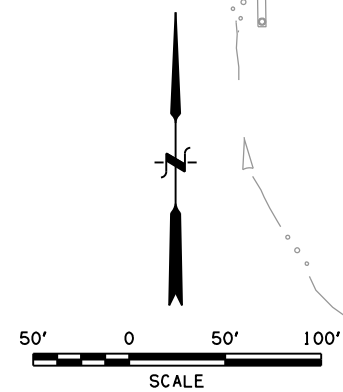

REMOVAL LEGEND	
	- PREVIOUS PHASE REMOVAL
	- ASPHALT REMOVAL

REMOVAL TOTALS THIS SHEET	
15960.03 S.Y.	ASPHALT PAVEMENT
1041.02 L.F.	CONC. CURB & GUTTER
199.13 L.F.	SAWCUT
1500.55 L.F.	CON. MED. BARRIER

NOTE: INTEGRAL CONC. CURB INCLUDED IN S.Y. QUANTITY OF P.C. CONC. PAVEMENT

DESIGN	-	-	PHASE 4
DRAWN	-	-	
CHECKED	-	-	
APPROVED	-	-	
SQUAD	POE		

OKLAHOMA COUNTY
REMOVALS
PHASE 4 CONSTRUCTION
 (SHEET 2 OF 6)
 STATE JOB NO. 090321081 SHEET NO. R097

SEC. 34, T11N, R3W

85+00
(SEE SHEET 6 OF 6)

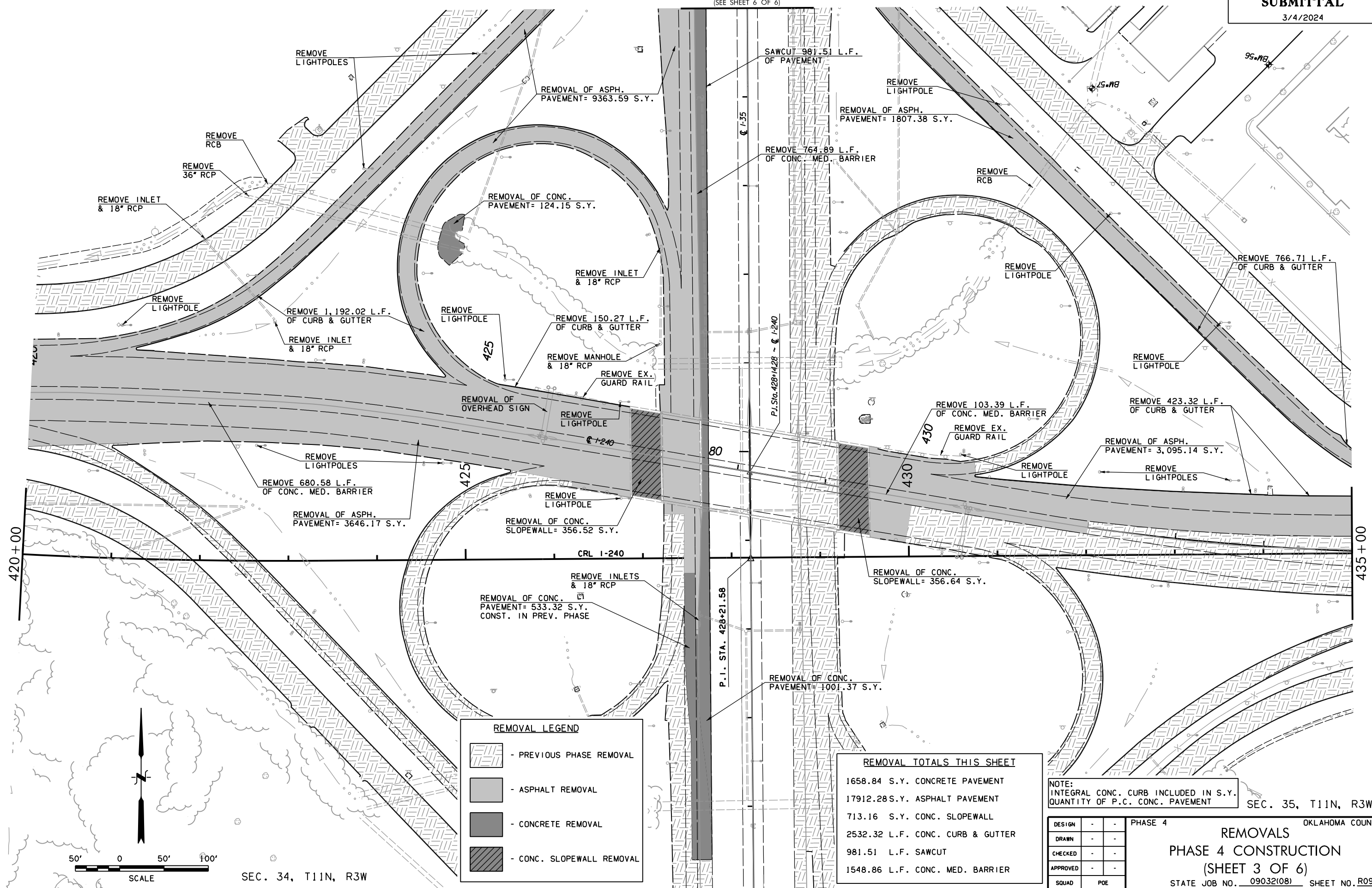

REMOVAL LEGEND

	- PREVIOUS PHASE REMOVAL
	- ASPHALT REMOVAL
	- CONCRETE REMOVAL
	- CONC. SLOPEWALL REMOVAL

REMOVAL TOTALS THIS SHEET

1658.84 S.Y.	CONCRETE PAVEMENT
17912.28 S.Y.	ASPHALT PAVEMENT
713.16 S.Y.	CONC. SLOPEWALL
2532.32 L.F.	CONC. CURB & GUTTER
981.51 L.F.	SAWCUT
1548.86 L.F.	CONC. MED. BARRIER

NOTE:
INTEGRAL CONC. CURB INCLUDED IN S.Y.
QUANTITY OF P.C. CONC. PAVEMENT

DESIGN	-	-
DRAWN	-	-
CHECKED	-	-
APPROVED	-	-
SQUAD	POE	

PHASE 4
REMOVALS
PHASE 4 CONSTRUCTION
(SHEET 3 OF 6)
STATE JOB NO. 090321081 SHEET NO. R098

3/4/2024 2:40:48 PM H:\PROJECTS\2789_CrossRoads_Phase 4\Roadway\Drawings\0903208-Phase 4 Removals_3.dgn

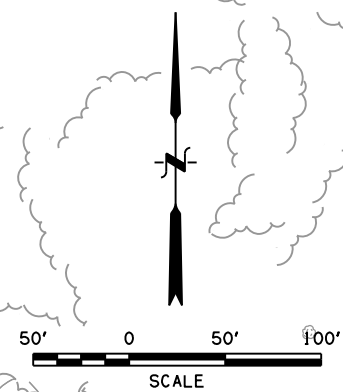

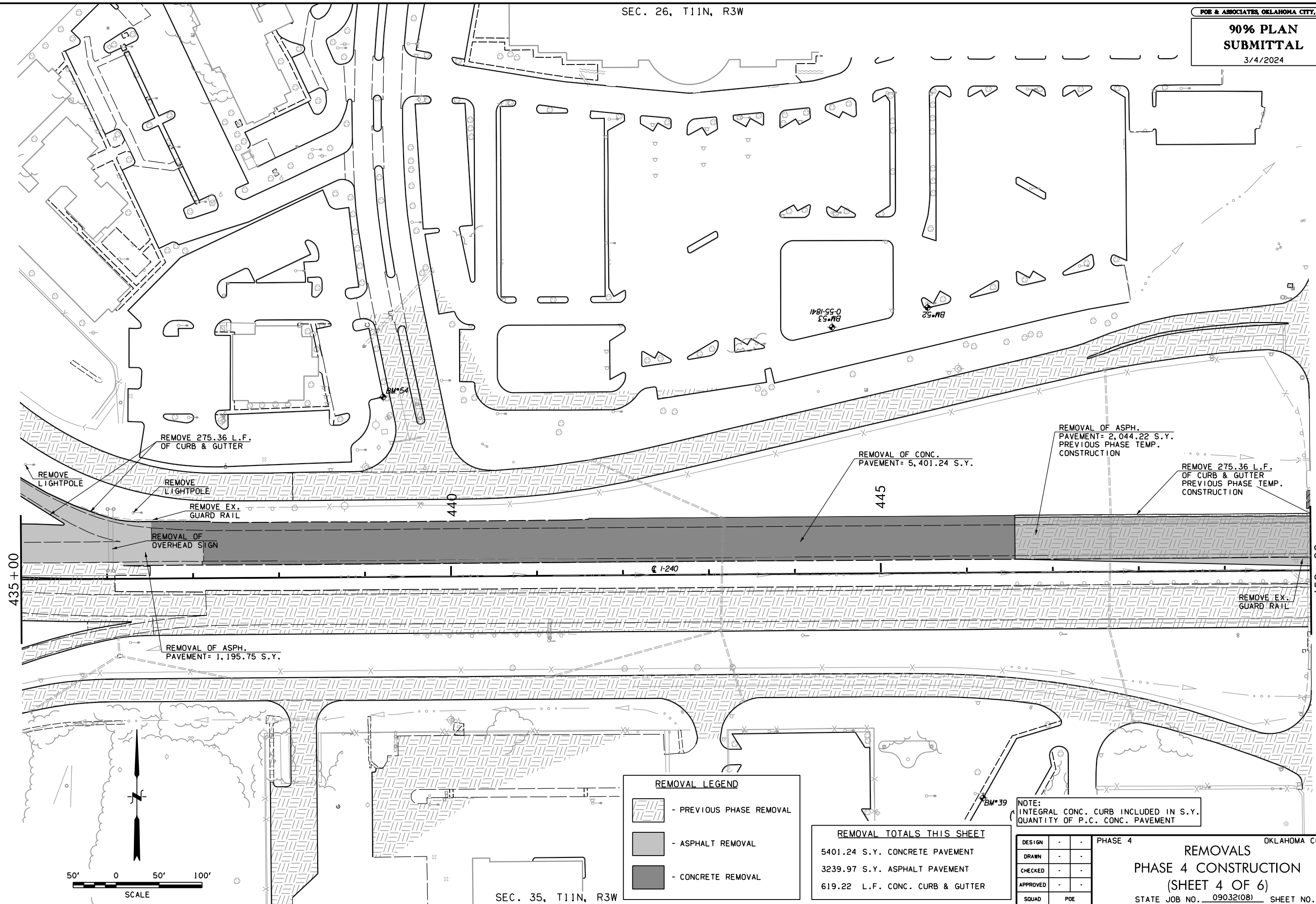

3/4/2024 2:40:49 PM
H:\PROJECTS\2789_CrossRoads_Phase 4\Roadway\Drawings\0903208-Phase 4 Removals.dgn

REMOVAL LEGEND

	- PREVIOUS PHASE REMOVAL
	- ASPHALT REMOVAL
	- CONCRETE REMOVAL

REMOVAL TOTALS THIS SHEET

5401.24 S.Y. CONCRETE PAVEMENT
3239.97 S.Y. ASPHALT PAVEMENT
619.22 L.F. CONC. CURB & GUTTER

NOTE:
INTEGRAL CONC. CURB INCLUDED IN S.Y.
QUANTITY OF P.C. CONC. PAVEMENT

DESIGN	-	-	PHASE 4
DRAWN	-	-	
CHECKED	-	-	
APPROVED	-	-	
SQUAD	POE		

OKLAHOMA COUNTY
REMOVALS
PHASE 4 CONSTRUCTION
(SHEET 4 OF 6)
STATE JOB NO. 090321081 SHEET NO. R099

3/4/2024 2:40:50 PM
H:\PROJECTS\2789_CrossRoads_Phase 4\Roadway\Drawings\0903208-Phase 4 Removals.dgn

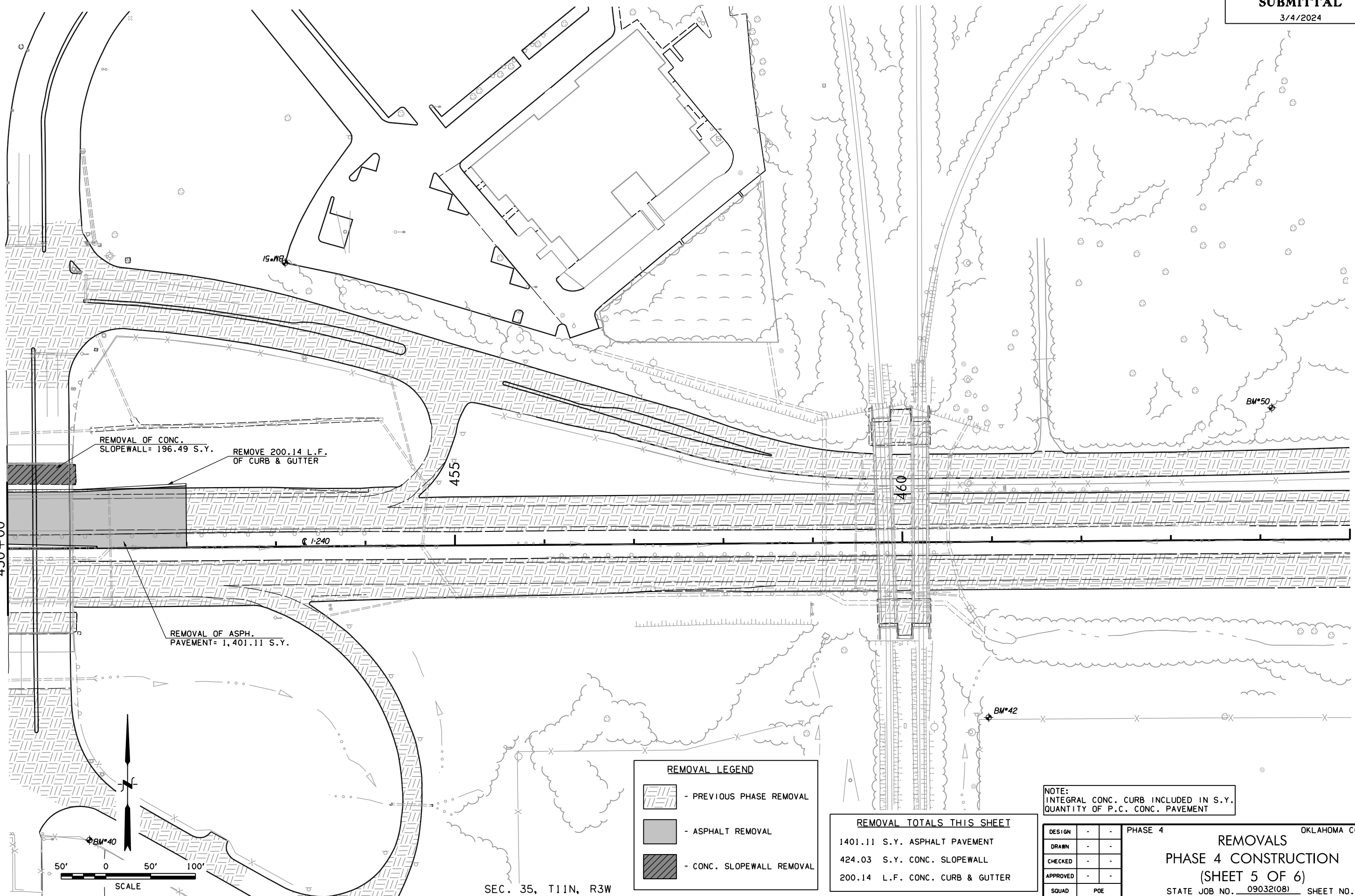

REMOVAL OF CONC.
SLOPEWALL= 196.49 S.Y. REMOVE 200.14 L.F.
OF CURB & GUTTER

REMOVAL OF ASPH.
PAVEMENT= 1,401.11 S.Y.

REMOVAL LEGEND

	- PREVIOUS PHASE REMOVAL
	- ASPHALT REMOVAL
	- CONC. SLOPEWALL REMOVAL

REMOVAL TOTALS THIS SHEET

1401.11 S.Y. ASPHALT PAVEMENT
424.03 S.Y. CONC. SLOPEWALL
200.14 L.F. CONC. CURB & GUTTER

NOTE:
INTEGRAL CONC. CURB INCLUDED IN S.Y.
QUANTITY OF P.C. CONC. PAVEMENT

DESIGN	-	-
DRAWN	-	-
CHECKED	-	-
APPROVED	-	-
SQUAD	POE	

PHASE 4
REMOVALS
PHASE 4 CONSTRUCTION
(SHEET 5 OF 6)
STATE JOB NO. 09032108 SHEET NO. R100

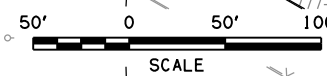

SEC. 27, T11N, R3W

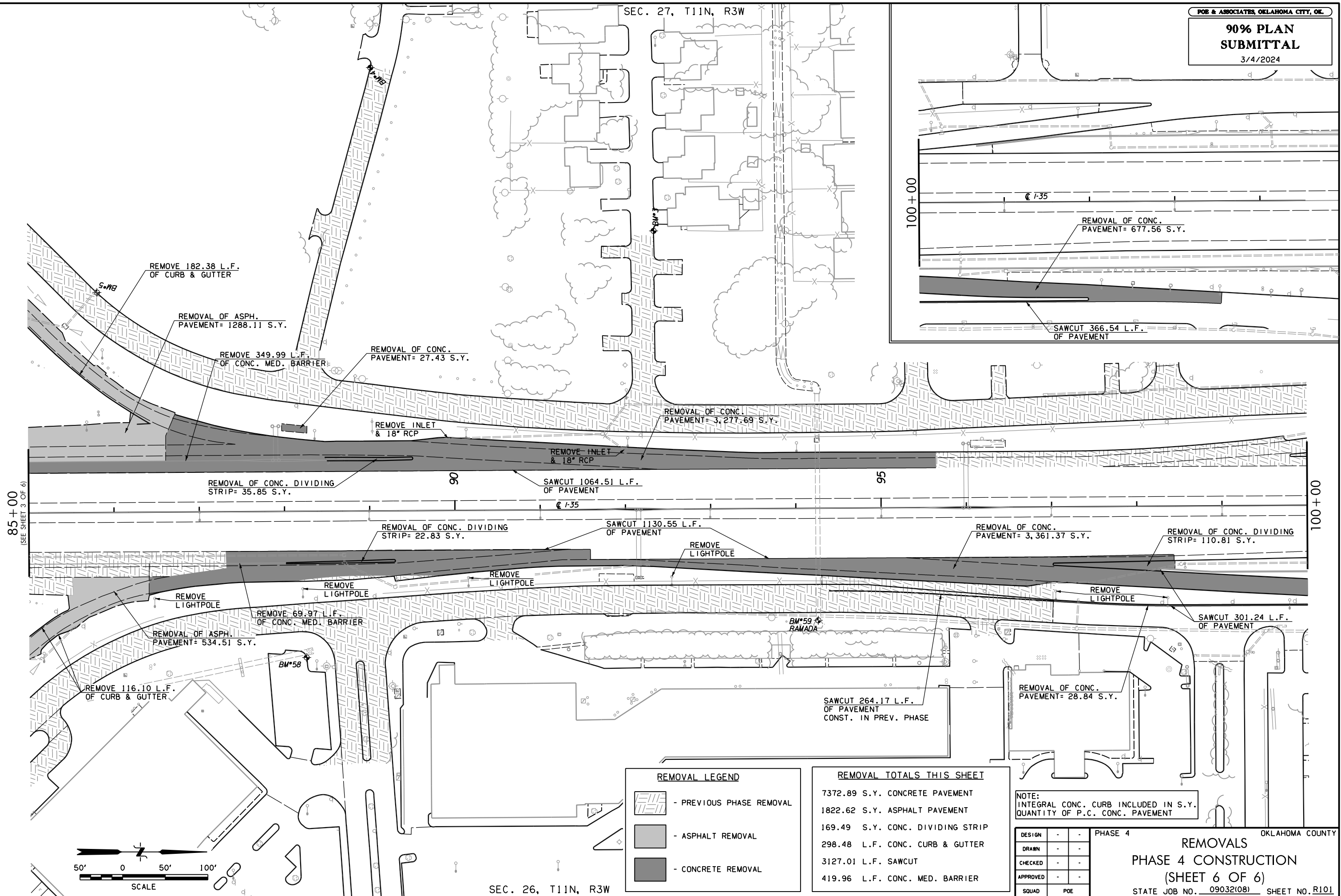
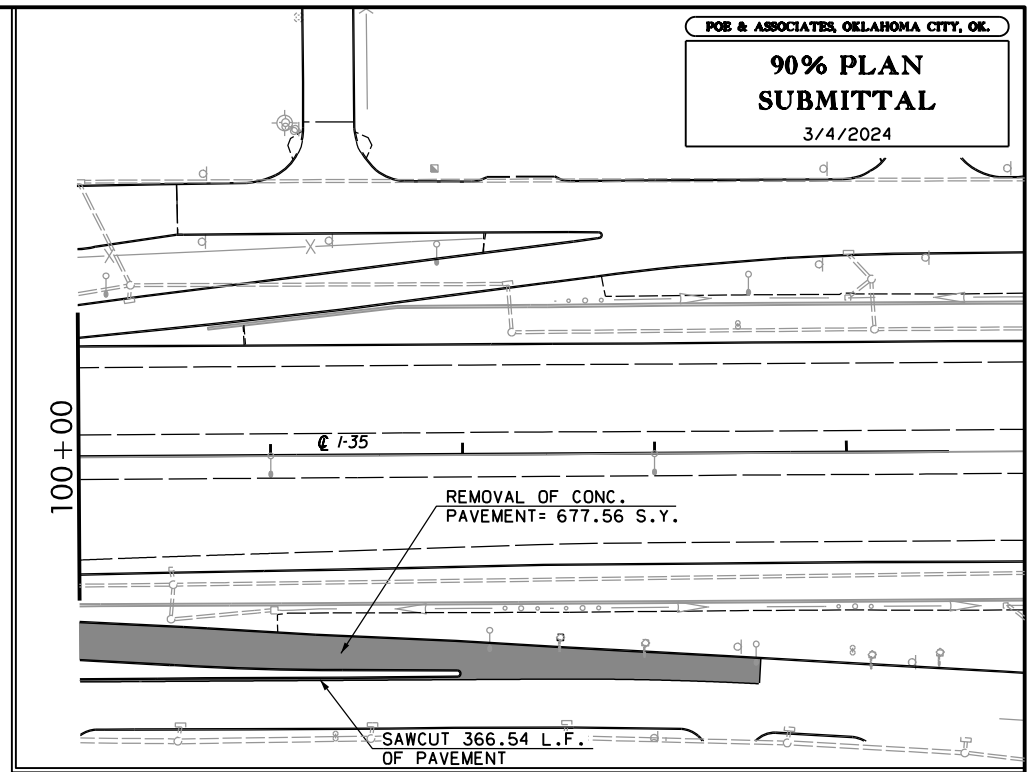

85+00
(SEE SHEET 3 OF 6)

100+00

REMOVAL LEGEND

	- PREVIOUS PHASE REMOVAL
	- ASPHALT REMOVAL
	- CONCRETE REMOVAL

REMOVAL TOTALS THIS SHEET

7372.89 S.Y.	CONCRETE PAVEMENT
1822.62 S.Y.	ASPHALT PAVEMENT
169.49 S.Y.	CONC. DIVIDING STRIP
298.48 L.F.	CONC. CURB & GUTTER
3127.01 L.F.	SAWCUT
419.96 L.F.	CONC. MED. BARRIER

NOTE:
 INTEGRAL CONC. CURB INCLUDED IN S.Y.
 QUANTITY OF P.C. CONC. PAVEMENT

DESIGN	-	-	PHASE 4
DRAWN	-	-	
CHECKED	-	-	
APPROVED	-	-	
SQUAD	POE		

OKLAHOMA COUNTY
REMOVALS
PHASE 4 CONSTRUCTION
 (SHEET 6 OF 6)
 STATE JOB NO. 09032108 SHEET NO. R101

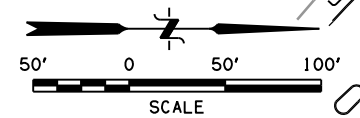

SEC. 26, T11N, R3W

3/4/2024 2:40:51 PM H:\PROJECTS\2789_CrossRoads_Phase 4\Roadway\Drawings\0903208-Phase 4 Removals.dwg

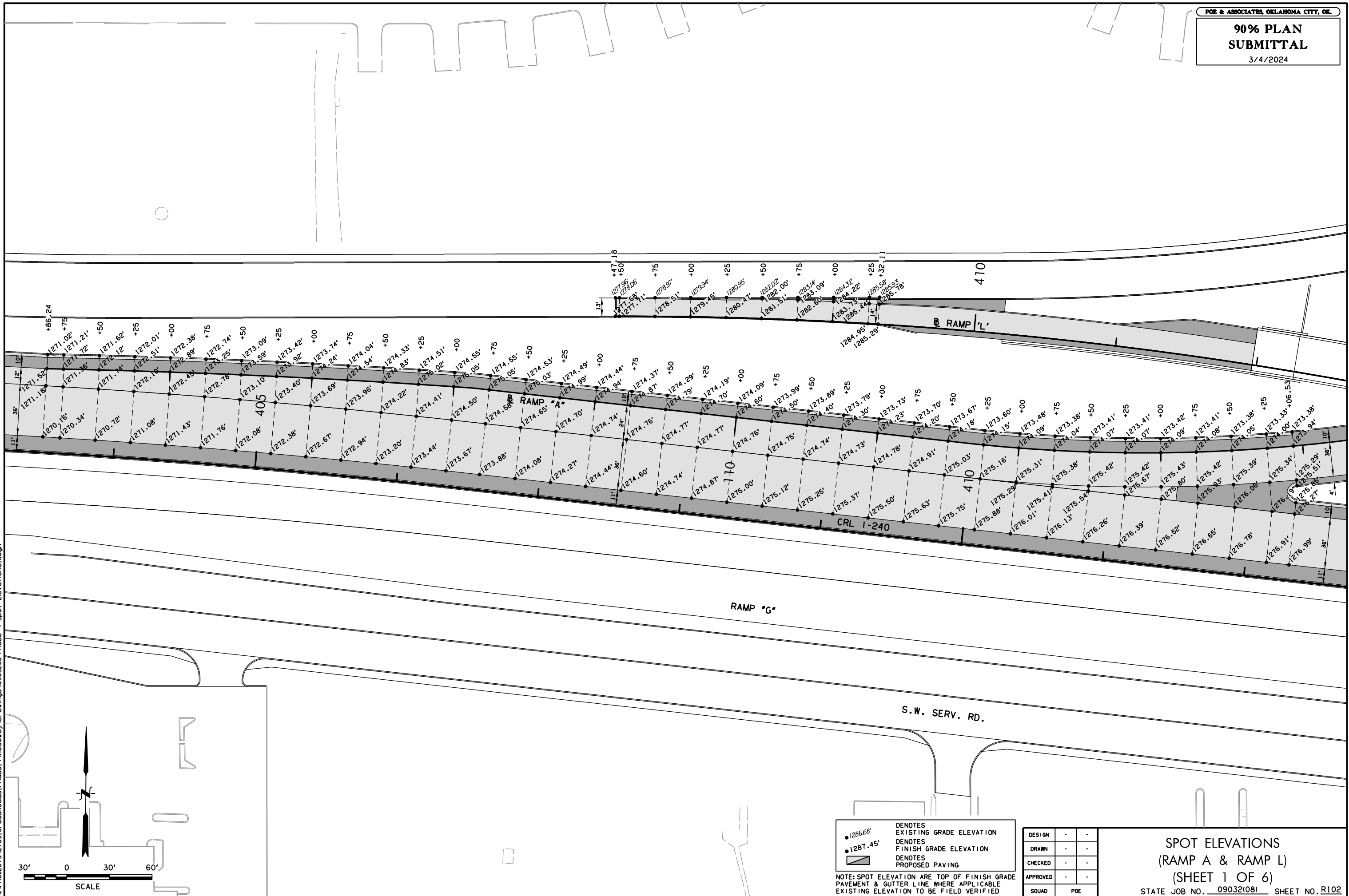

3/4/2024 2:40:54 PM
 H:\PROJECTS\2789_CrossRoads_Phase 4\Roadway\Drawings\0903208-Phase 4 Spot Elevations.dgn

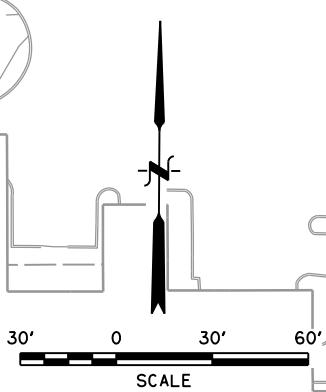

● 1286.68' DENOTES EXISTING GRADE ELEVATION
 ● 1287.45' DENOTES FINISH GRADE ELEVATION
 [Shaded Area] DENOTES PROPOSED PAVING

NOTE: SPOT ELEVATIONS ARE TOP OF FINISH GRADE PAVEMENT & GUTTER LINE WHERE APPLICABLE EXISTING ELEVATION TO BE FIELD VERIFIED

DESIGN	-	-
DRAWN	-	-
CHECKED	-	-
APPROVED	-	-
SQUAD	POE	

**SPOT ELEVATIONS
 (RAMP A & RAMP L)
 (SHEET 1 OF 6)**
 STATE JOB NO. 09032108 SHEET NO. R102

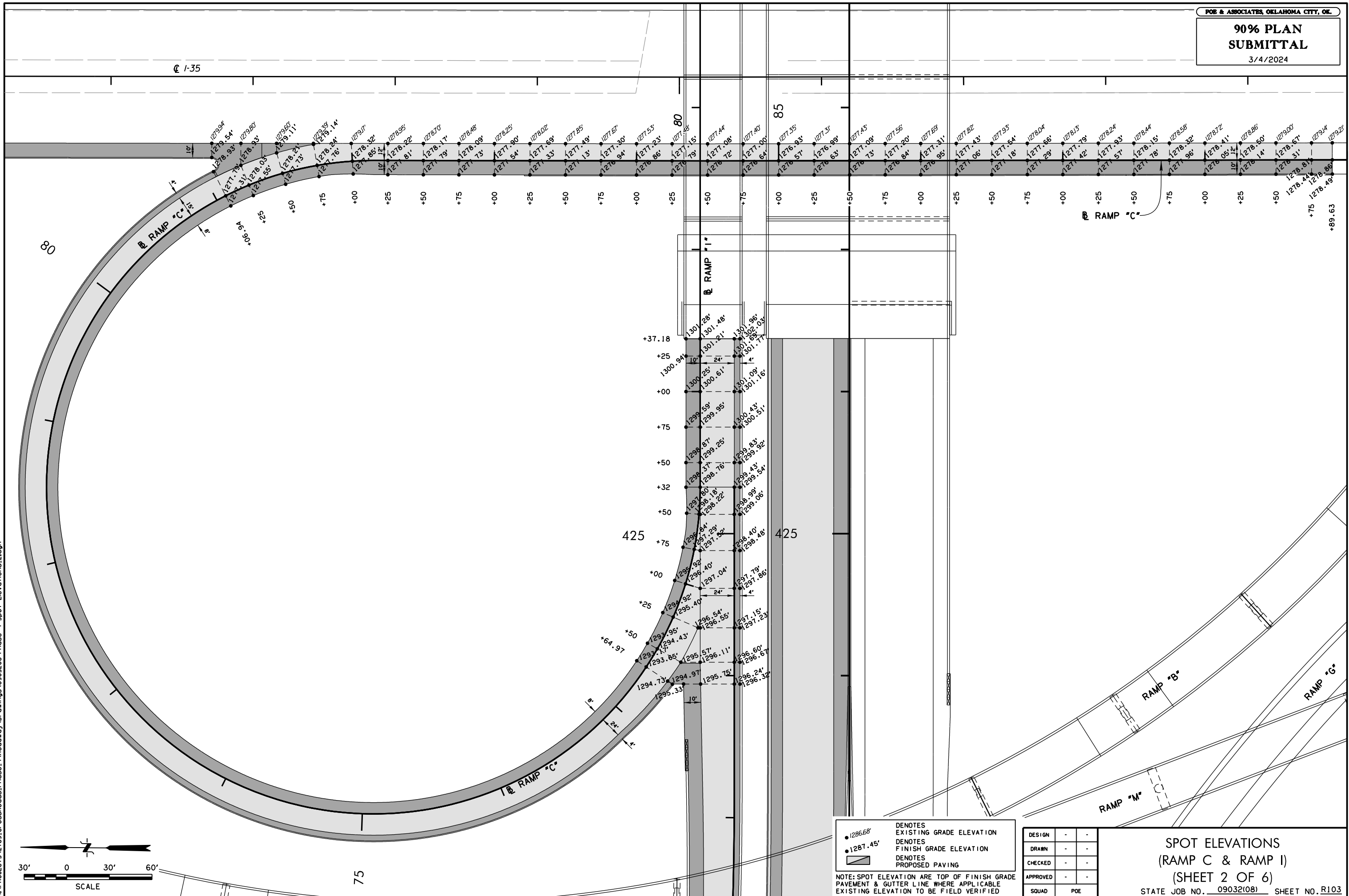

3/4/2024 2:40:56 PM
 H:\PROJECTS\2789_Crossroads_Phase 4\Roadway\Drawings\0903208-Phase 4 Spot Elevations.2.dgn

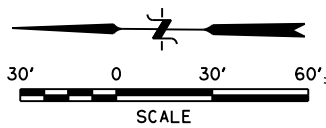

● 1286.68' DENOTES EXISTING GRADE ELEVATION
 ● 1287.45' DENOTES FINISH GRADE ELEVATION
 ▨ DENOTES PROPOSED PAVING

NOTE: SPOT ELEVATION ARE TOP OF FINISH GRADE PAVEMENT & GUTTER LINE WHERE APPLICABLE
 EXISTING ELEVATION TO BE FIELD VERIFIED

DESIGN	-	-
DRAWN	-	-
CHECKED	-	-
APPROVED	-	-
SQUAD	POE	

**SPOT ELEVATIONS
 (RAMP C & RAMP I)**
 (SHEET 2 OF 6)
 STATE JOB NO. 09032108 SHEET NO. R103

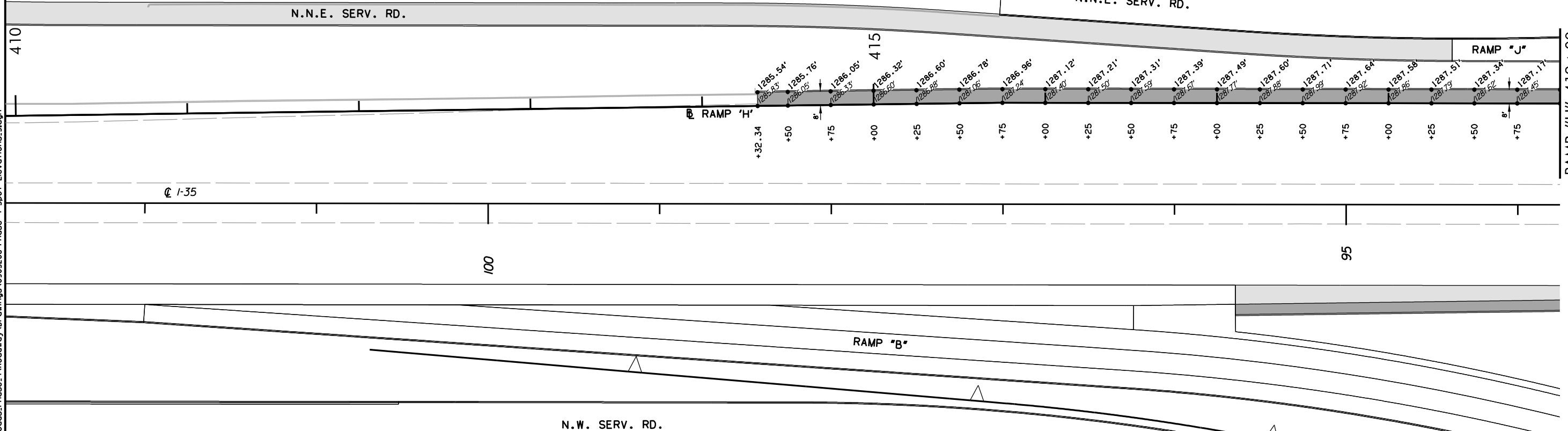
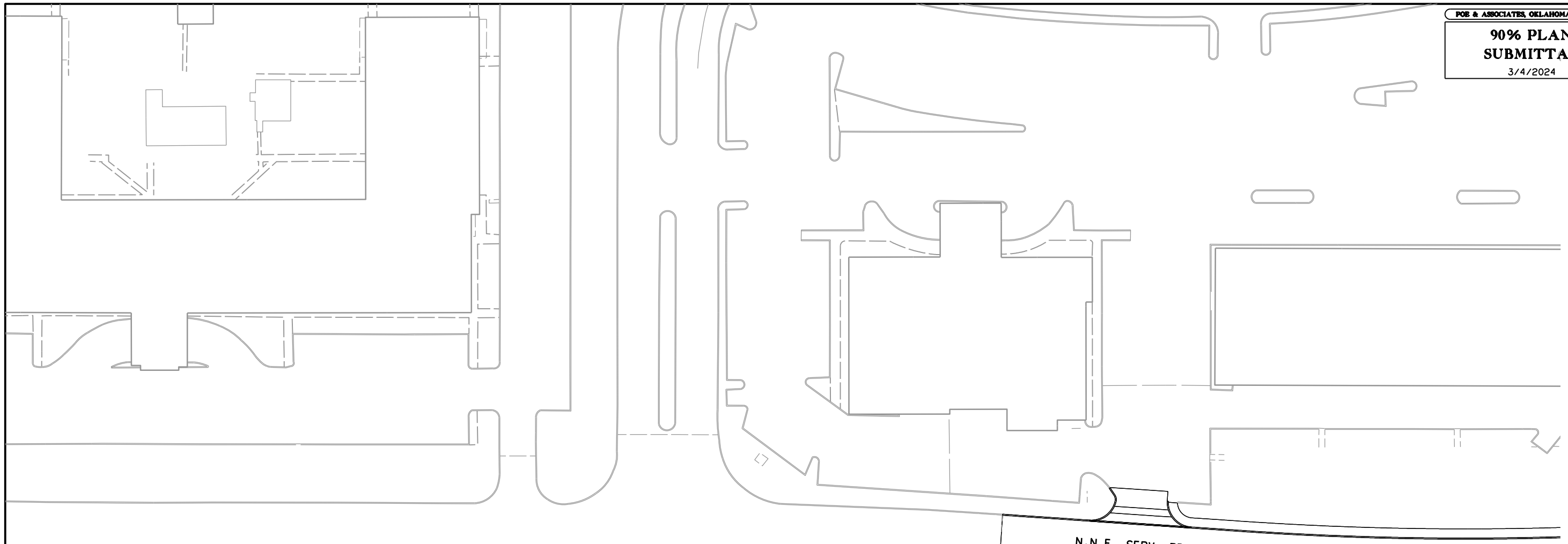

3/4/2024 2:40:57 PM H:\PROJECTS\2789_CrossRoads_Phase 4\Roadway\Drawings\0903208-Phase 4 Spot Elevations.dgn

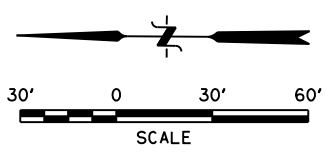

● 1286.68' DENOTES EXISTING GRADE ELEVATION
 ● 1287.45' DENOTES FINISH GRADE ELEVATION
 ▨ DENOTES PROPOSED PAVING
 NOTE: SPOT ELEVATION ARE TOP OF FINISH GRADE PAVEMENT & GUTTER LINE WHERE APPLICABLE EXISTING ELEVATION TO BE FIELD VERIFIED

DESIGN	-	-
DRAWN	-	-
CHECKED	-	-
APPROVED	-	-
SQUAD	POE	

**SPOT ELEVATIONS
 (RAMP H)**
(SHEET 3 OF 6)
 STATE JOB NO. 090321081 SHEET NO. R104

410

415

RAMP "H" 419+00

N.N.E. SERV. RD.

N.N.E. SERV. RD.

RAMP "H"

RAMP "J"

1-35

100

95

RAMP "B"

N.W. SERV. RD.

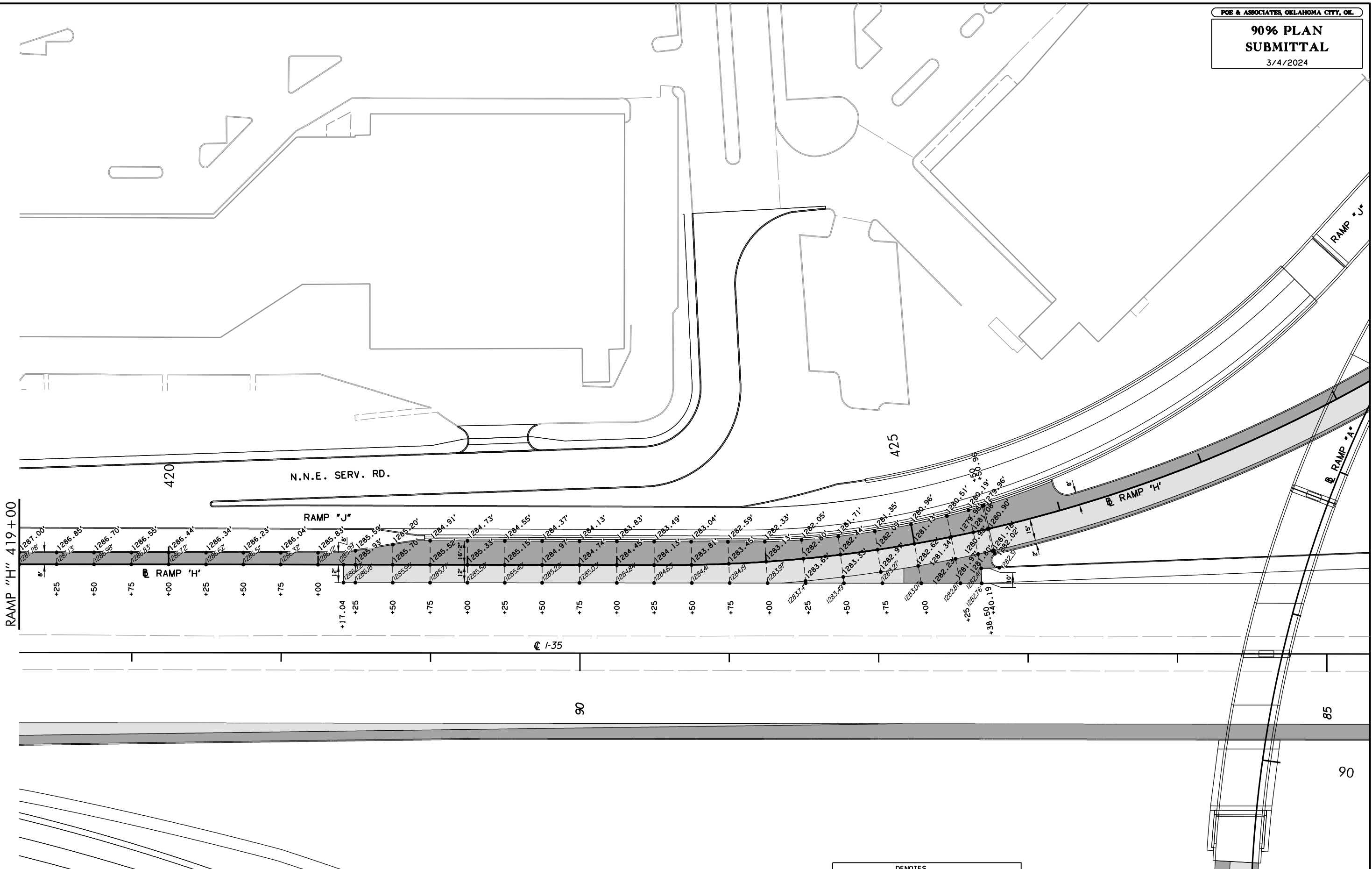

3/4/2024 2:40:58 PM
 H:\PROJECTS\2789_CrossRoads_Phase 4\Roadway\Drawings\0903208-Phase 4 Spot Elevations.dgn

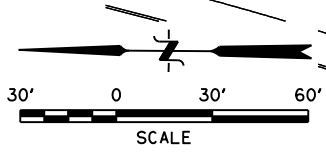

• 1286.68' DENOTES EXISTING GRADE ELEVATION
 • 1287.45' DENOTES FINISH GRADE ELEVATION
 [Shaded Area] DENOTES PROPOSED PAVING

NOTE: SPOT ELEVATIONS ARE TOP OF FINISH GRADE PAVEMENT & GUTTER LINE WHERE APPLICABLE EXISTING ELEVATION TO BE FIELD VERIFIED

DESIGN	-	-
DRAWN	-	-
CHECKED	-	-
APPROVED	-	-
SQUAD	POE	

**SPOT ELEVATIONS
 (RAMP H)**
(SHEET 4 OF 6)
 STATE JOB NO. 090321081 SHEET NO. R105

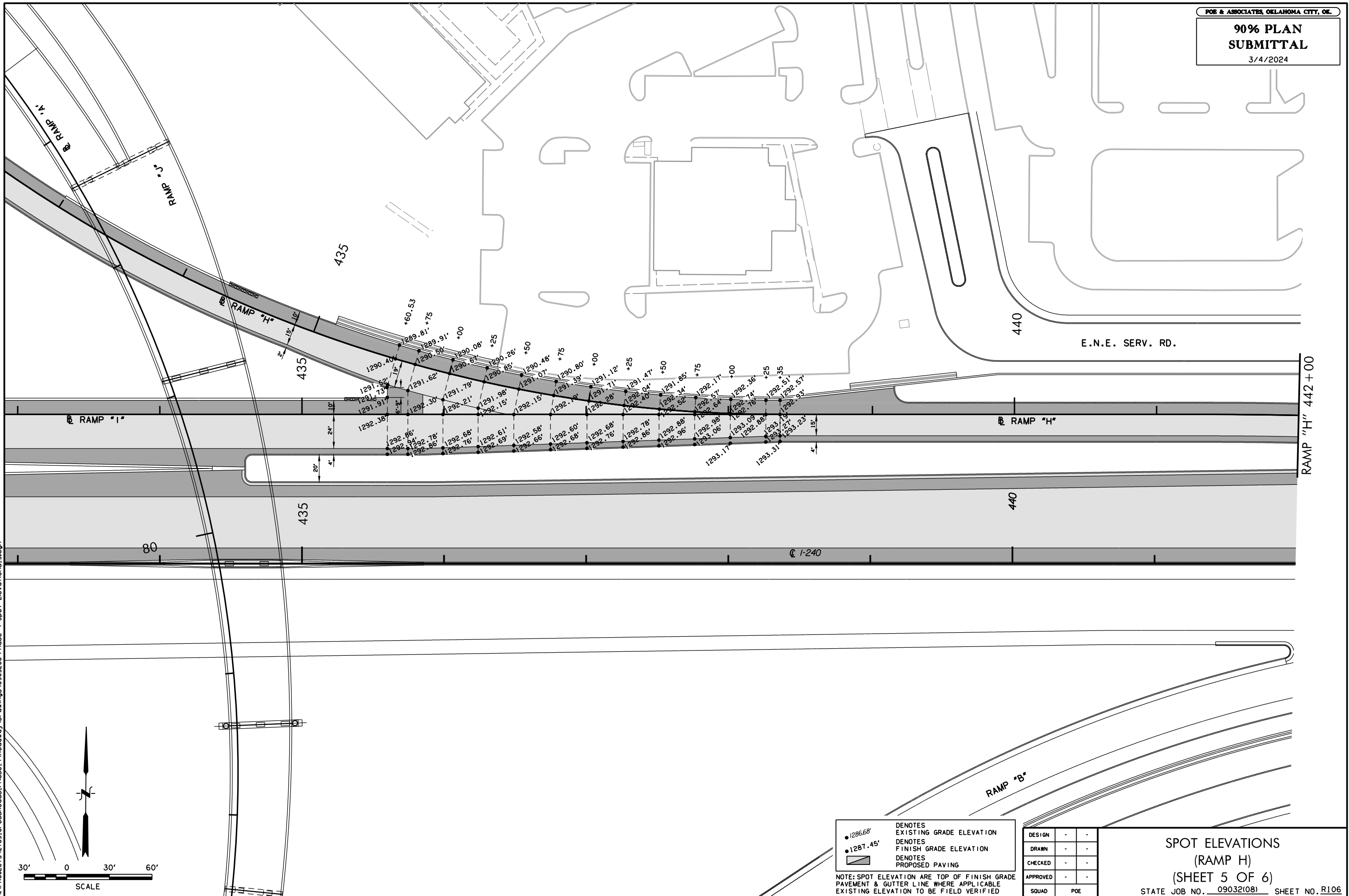

3/4/2024 2:41:00 PM H:\PROJECTS\2789_CrossRoads_Phase 4\Roadway\Drawings\0903208-Phase 4 Spot Elevations.5.dgn

● 1286.68' DENOTES EXISTING GRADE ELEVATION
 ● 1287.45' DENOTES FINISH GRADE ELEVATION
 [Shaded Area] DENOTES PROPOSED PAVING

NOTE: SPOT ELEVATION ARE TOP OF FINISH GRADE PAVEMENT & GUTTER LINE WHERE APPLICABLE EXISTING ELEVATION TO BE FIELD VERIFIED

DESIGN	-	-
DRAWN	-	-
CHECKED	-	-
APPROVED	-	-
SQUAD	POE	

SPOT ELEVATIONS
 (RAMP H)
 (SHEET 5 OF 6)
 STATE JOB NO. 090321081 SHEET NO. R106

E.N.E. SERV. RD.

RAMP "H" 442+00

RAMP "H"

445

445

450

1-240

RAMP "B"

S.E. SERV. RD.

- 1286.68' DENOTES EXISTING GRADE ELEVATION
- 1287.45' DENOTES FINISH GRADE ELEVATION
- ▨ DENOTES PROPOSED PAVING

NOTE: SPOT ELEVATION ARE TOP OF FINISH GRADE PAVEMENT & GUTTER LINE WHERE APPLICABLE EXISTING ELEVATION TO BE FIELD VERIFIED

DESIGN	-	-
DRAWN	-	-
CHECKED	-	-
APPROVED	-	-
SQUAD	POE	

SPOT ELEVATIONS
(RAMP H)
(SHEET 6 OF 6)

STATE JOB NO. 090321081 SHEET NO. R107

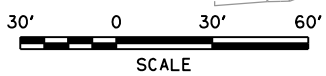

3/4/2024 2:40:01 PM H:\PROJECTS\2789_CrossRoads_Phase 4\Roadway\Drawings\0903208-Phase 4 Spot Elevations.dgn

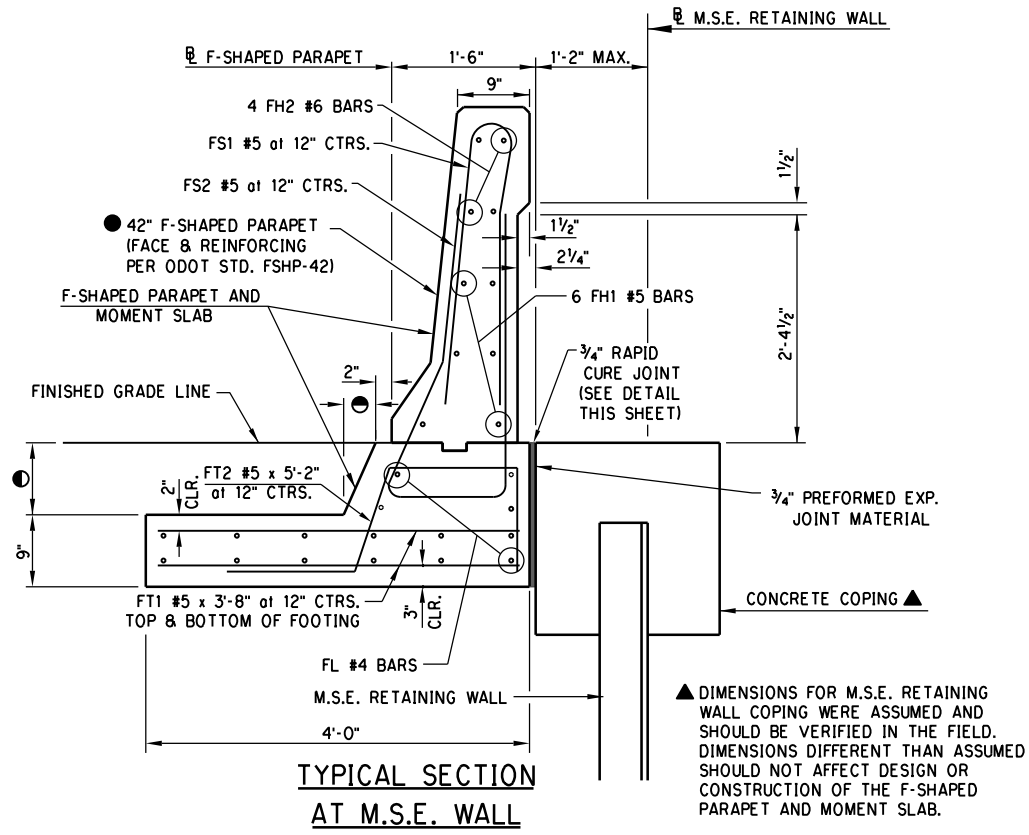

TYPICAL SECTION AT M.S.E. WALL

▲ DIMENSIONS FOR M.S.E. RETAINING WALL COPING WERE ASSUMED AND SHOULD BE VERIFIED IN THE FIELD. DIMENSIONS DIFFERENT THAN ASSUMED SHOULD NOT AFFECT DESIGN OR CONSTRUCTION OF THE F-SHAPED PARAPET AND MOMENT SLAB.

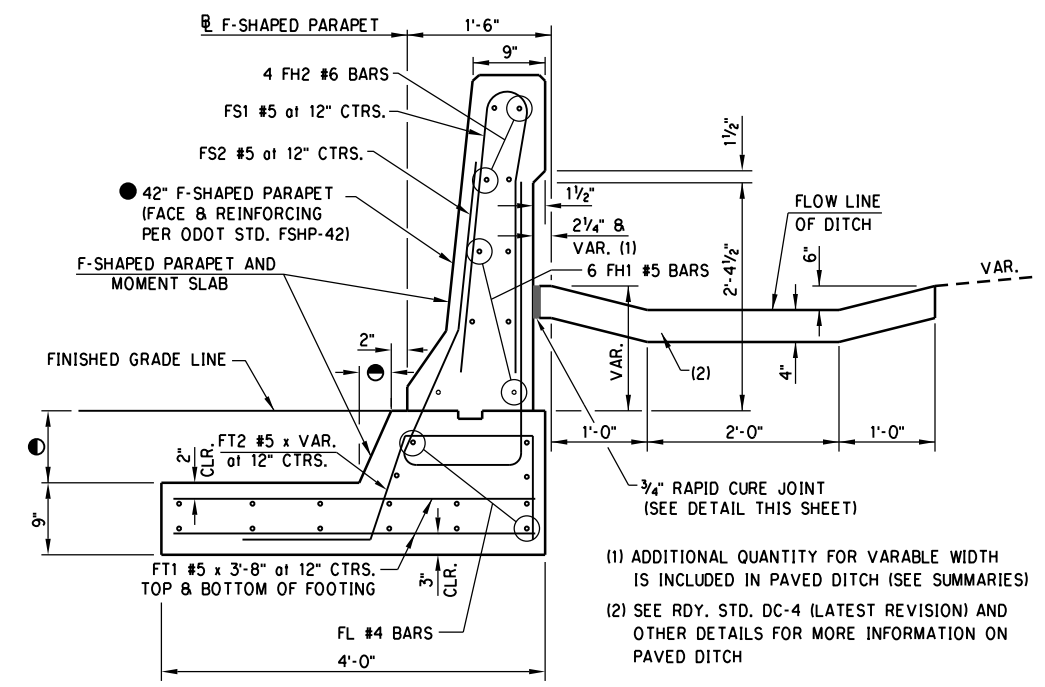

TYPICAL SECTION AT PAVED DITCH

- (1) ADDITIONAL QUANTITY FOR VARIABLE WIDTH IS INCLUDED IN PAVED DITCH (SEE SUMMARIES)
- (2) SEE R.D.Y. STD. DC-4 (LATEST REVISION) AND OTHER DETAILS FOR MORE INFORMATION ON PAVED DITCH

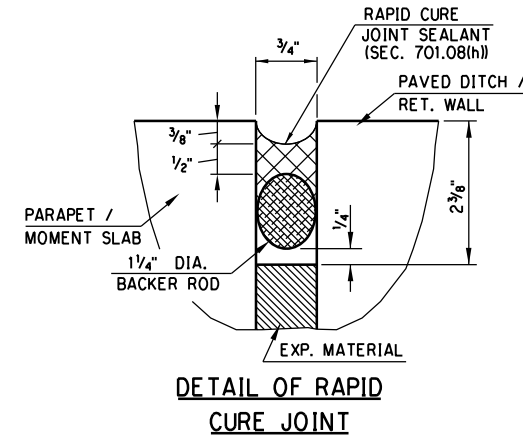

DETAIL OF RAPID CURE JOINT

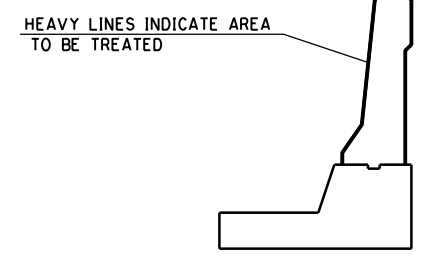

DETAIL OF PENETRATING WATER REPELLANT SURFACE TREATMENT

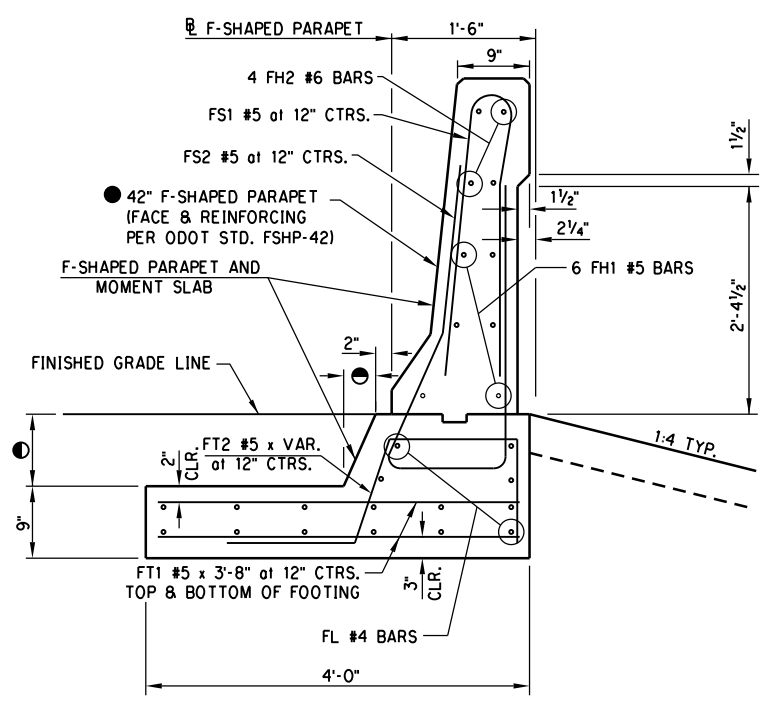

TYPICAL SECTION

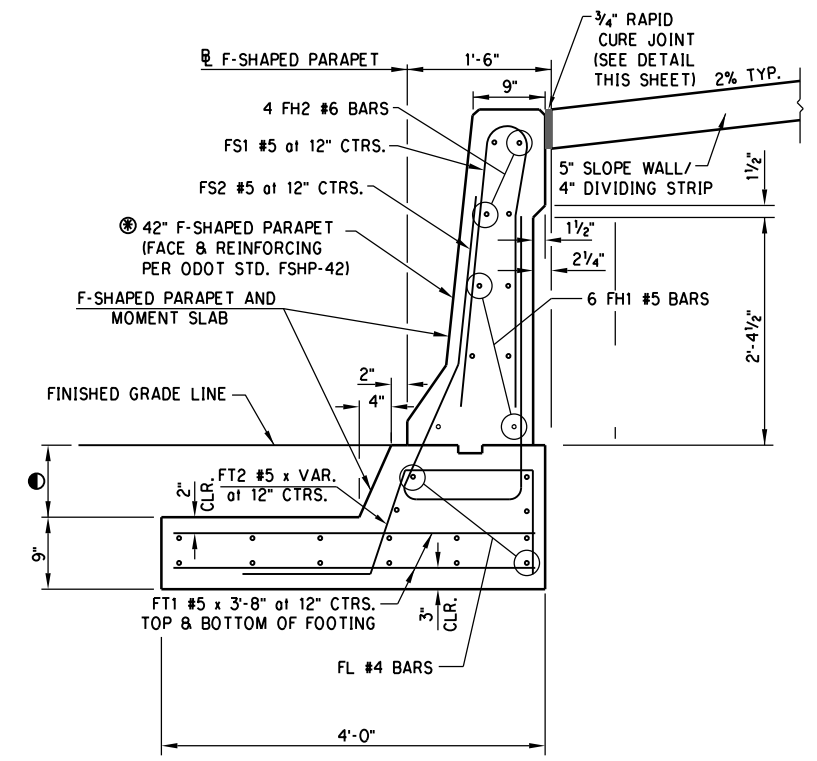

TYPICAL SECTION AT SLOPE WALL/DIVIDING STRIP

MOMENT SLAB EXTENTS:

- WESTBOUND I-240 - STA. 430+05.83 TO STA. 434+59.79 LT.
STA. 449+30.83 TO STA. 452+00.00 LT.
- RAMP 'A' - STA. 103+50.00 TO STA. 105+00.00 RT.
- RAMP 'H' - STA. 433+00.00 TO STA. 434+32.00 LT.
- RAMP 'I' - STA. 425+32.69 TO STA. 426+37.18 RT.
STA. 430+05.68 TO STA. 434+59.79 LT. & RT.
STA. 422+00.00 TO STA. 423+33.00 LT. & RT.
- RAMP 'L' - STA. 410+20.00 TO STA. 411+96.92 RT.
STA. 416+70.42 TO STA. 417+64.18 LT. & RT.
STA. 417+64.18 TO STA. 422+00.00 RT.
STA. 422+00.00 TO STA. 423+33.00 LT. & RT.
STA. 423+33.00 TO STA. 425+32.69 RT.

● SEE ODOT STANDARD FSHP-42-2-00E FOR EXPANSION, CONSTRUCTION, AND CONTROL CRACK JOINT LOCATIONS.

MOMENT SLAB TO BE PAID FOR AS CLASS A CONCRETE AND EPOXY COATED REINFORCING STEEL. FS2 BARS SHALL BE INCLUDED IN EPOXY COATED REINFORCING STEEL QUANTITY.

VARIABLE TABLE

●	5"	9"	10"
●	2 1/4"	4"	4 7/16"

NOTE: FS2 BARS INCLUDED IN EPOXY COATED REINFORCING STEEL

DESIGN		PHASE 4	OKLAHOMA COUNTY
DRAWN			
CHECKED			
APPROVED			
SQUAD	POE		

F-SHAPED PARAPET AND MOMENT SLAB DETAIL

3/4/2024 2:41:02 PM H:\PROJECTS\2789_CrossRoads_Phase 4\Roadway\Drawings\0903208-Phase 4 F-Shape Detail.dgn

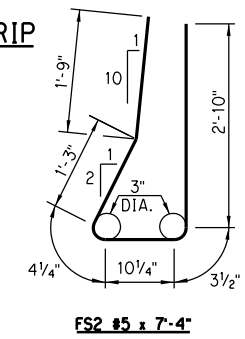
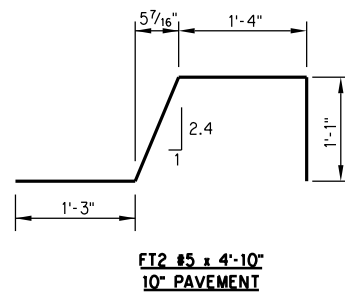
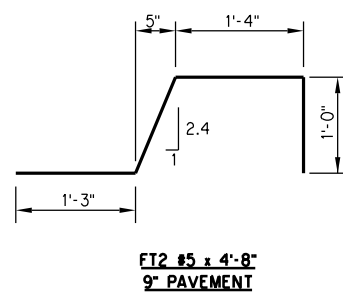
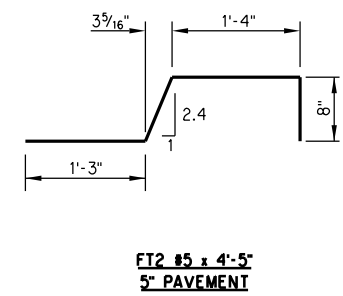

**90% PLAN
SUBMITTAL**

3/4/2024

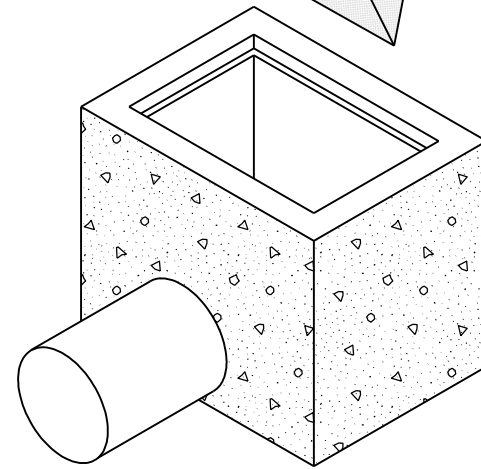
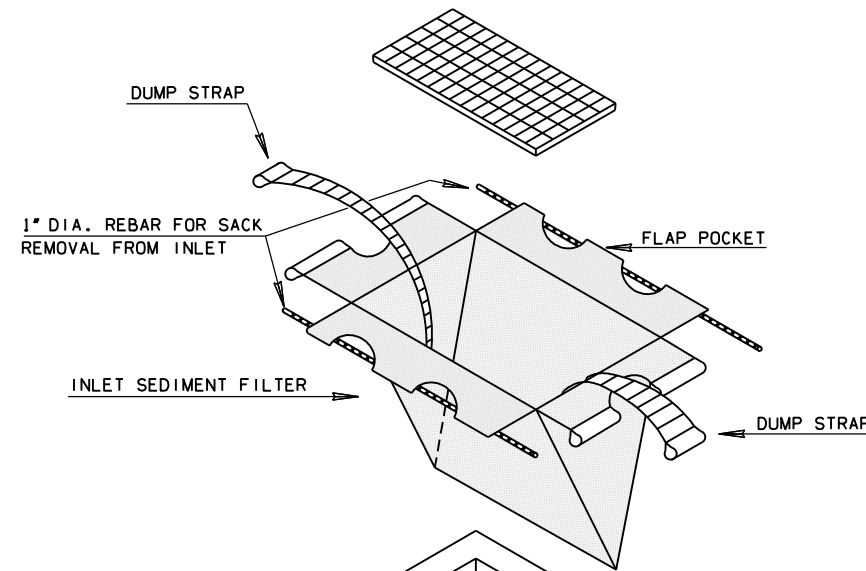

INSTALLATION DETAIL

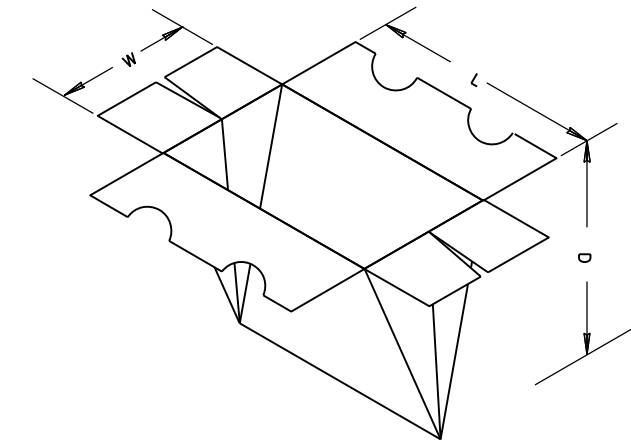
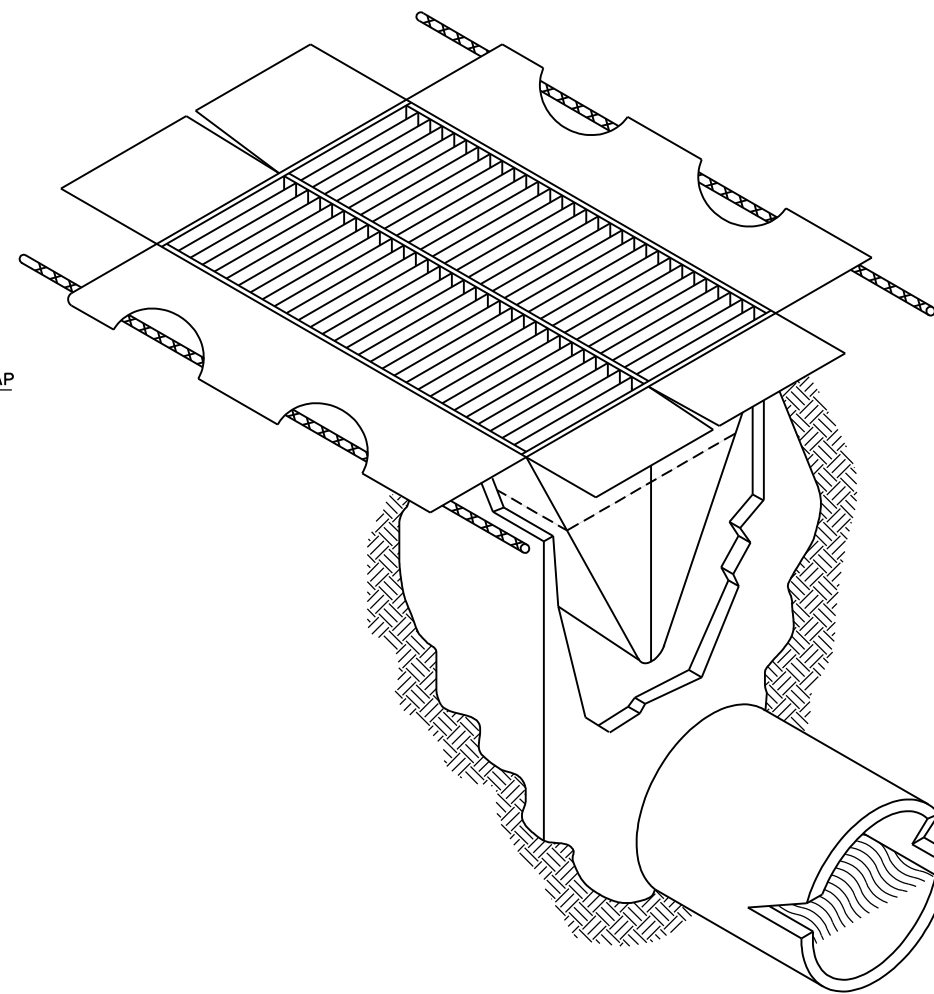

GERNERAL NOTES

AN INLET SEDIMENT FILTER IS A WOVEN, POLYPROPLENE SACK PLACED INTO UNDERGROUND DRAINS DESIGNED TO TRAP SEDIMENT BEFORE IT ENTERS THE DRAINAGE SYSTEM. THE FILTER HAS FLAP POCKETS ALONG THE TOP EDGES AND DUMP STRAPS ATTACHED TO THE BOTTOM THAT REMAIN ABOVE THE GROUND AND ARE HELD IN PLACE BY THE GRATE. THE FILTER MUST NEVER BE ALLOWED TO BE OVER HALF FULL OF SEDIMENT OR THE DRAINAGE SYSTEM COULD BE POLLUTED, NOT FUNCTION AT ALL OR MAKE IT VERY DIFFICULT TO REMOVE. CONSEQUENTLY, REGULAR MAINTENANCE IS MANDATORY.

WHEN IT IS DETERMINED THAT THE FILTER NEEDS TO BE CLEANED, TWO PIECES OF 1" REBAR ARE INSERTED THROUGH THE FLAP POCKETS. THE GRATE IS REMOVED AND THE LIFTING BARS ARE ATTACHED TO AVAILABLE EQUIPMENT AND THE SEDIMENT FILTER IS REMOVED TO A DUMPING AREA. ONCE THE INLET SEDIMENT FILTER IS ON THE GROUND, REMOVE THE LIFTING BARS FROM THE FLAP POCKETS AND INSET THE LIFTING BARS THROUGH THE DUMP STRAPS. LIFT THE FILTER OFF THE GROUND BY THE DUMP STRAPS AND THE FILTER WILL TURN INSIDE OUT AND BE EMPTIED. IT MAY THEN BE RINSED AND REUSED OR DISPOSED OF AND REPLACED WITH A NEW INLET SEDIMENT FILTER.

THE GEOTEXTILE FABRIC SHALL BE WOVEN WITH THE FOLLOWING PROPERTIES:

PROPERTY	TEST METHOD	TEST RESULT
GRAB TENSILE	ASTM D-4632	300 lb (Min.)
GRAB ELONGATION	ASTM D-4632	20% (Max.)
PUNCTURE	ASTM D-4833	120 lb (Min.)
MULLEN BURST	ASTM D-3786	800 psi (Min.)
TRAPEZOID TEAR	ASTM D-4533	120 lb (Min.)
UV RESISTANCE	ASTM D-4355	70% @ 150hrs. (Min.)
APPARENT OPENING SIZE	ASTM D-4751	40 US SIEVE (Max.)
FLOW RATE	ASTM D-4491	40 Gal./min./sq.ft. (Max.)
PERMITTIVITY	ASTM D-4491	0.55 sec. ⁻¹ (Max.)

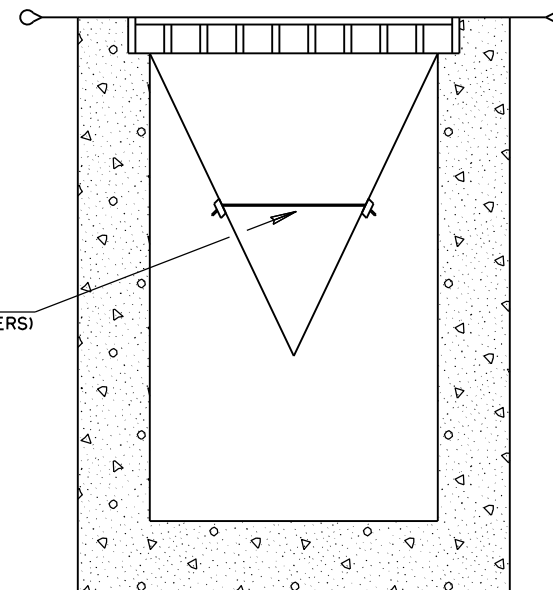

SIDE VIEW

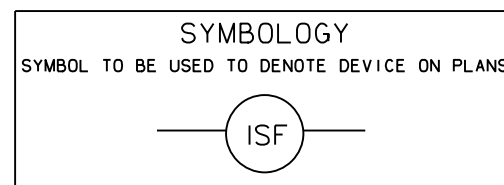

BASIS OF PAYMENT		
ITEM NO.	ITEM	UNIT
221(H)	(PL) TEMPORARY INLET SEDIMENT FILTER	EACH

DESIGN	-	-	PHASE 4	OKLAHOMA COUNTY
DRAWN	-	-	TEMPORARY INLET SEDIMENT FILTER STATE JOB NO. 09032108 SHEET NO. R109	
CHECKED	-	-		
APPROVED	-	-		
SQUAD	POE			

90% PLAN SUBMITTAL

3/4/2024

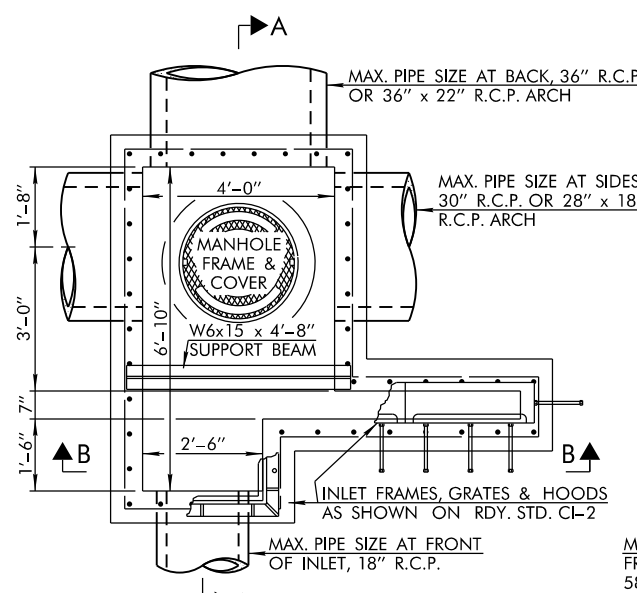

PLAN - DESIGN 1 W/SMALL JCT. BOX
(DESIGN 1B SHOWN)

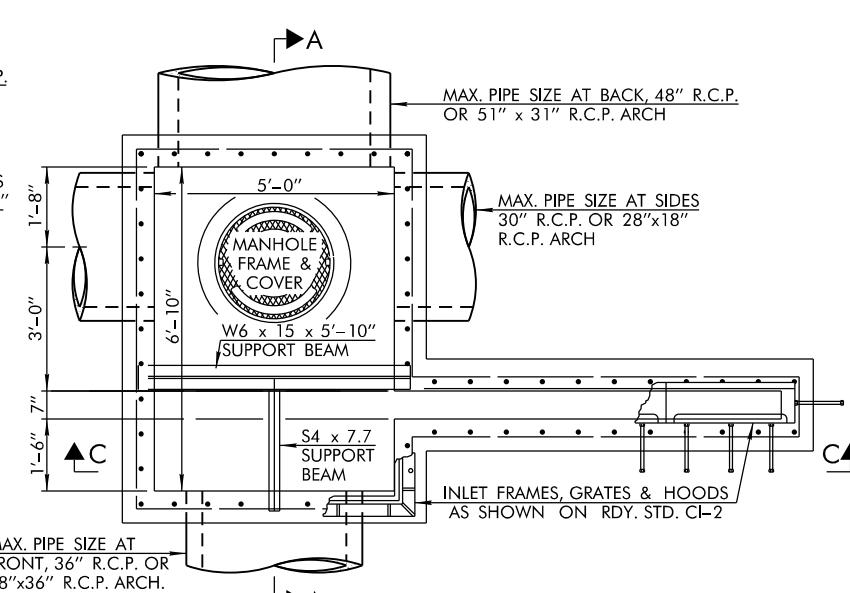

PLAN - DESIGN 2 W/SMALL JCT. BOX
(DESIGN 2C SHOWN)

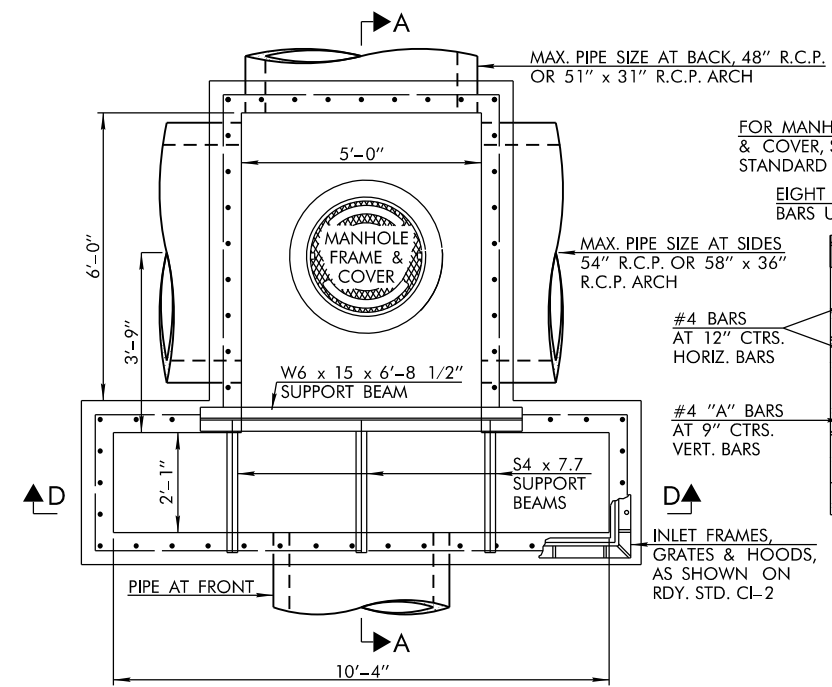

PLAN - DESIGN 3 W/LARGE JCT. BOX
(DESIGN 3 SHOWN)
(MULTIPLE DOUBLE GRATING)

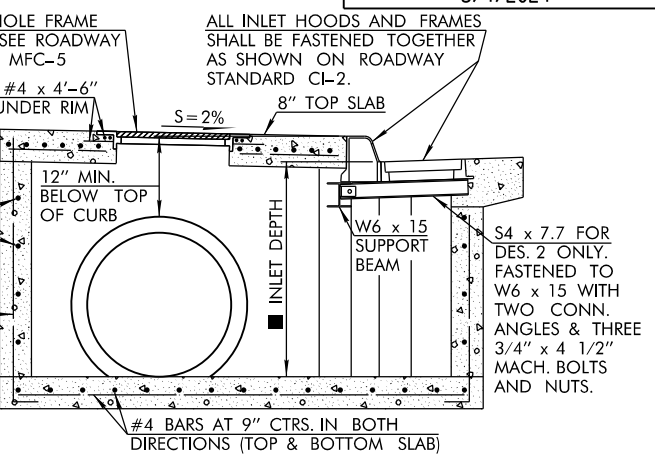

SECTION A-A

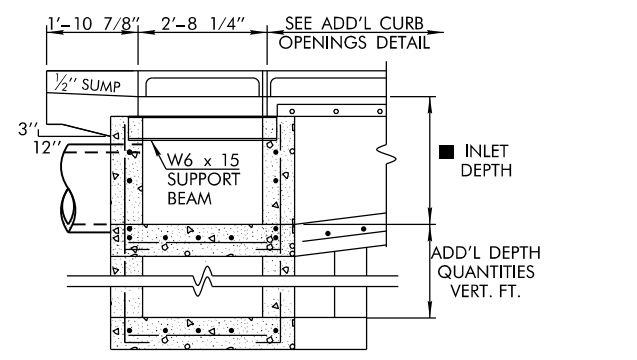

SECTION B-B

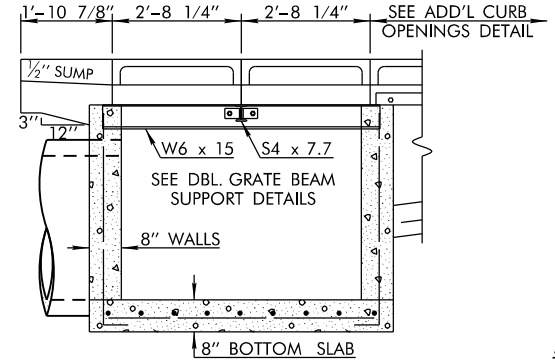

SECTION C-C

#4 "A" BAR
(VERTICAL BARS)

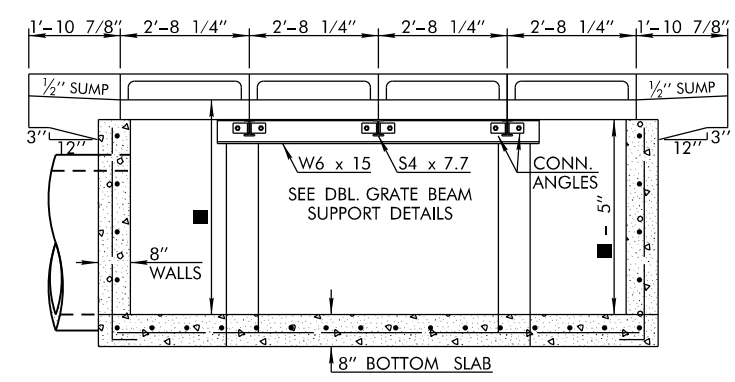

SECTION D-D

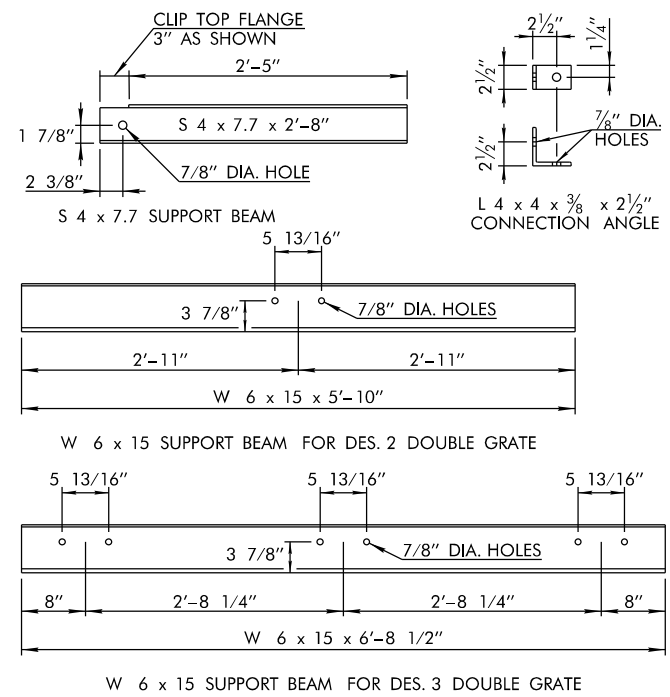

DOUBLE GRATE SUPPORT BEAM DETAILS

NOTE: S 4 x 7.7 SUPPORT BEAM(S) SHALL BE CONNECTED TO DOUBLE GRATE SUPPORT BEAMS USING CONNECTION ANGLES & 3/4" x 2" MACHINE BOLTS & NUTS AS REQUIRED.

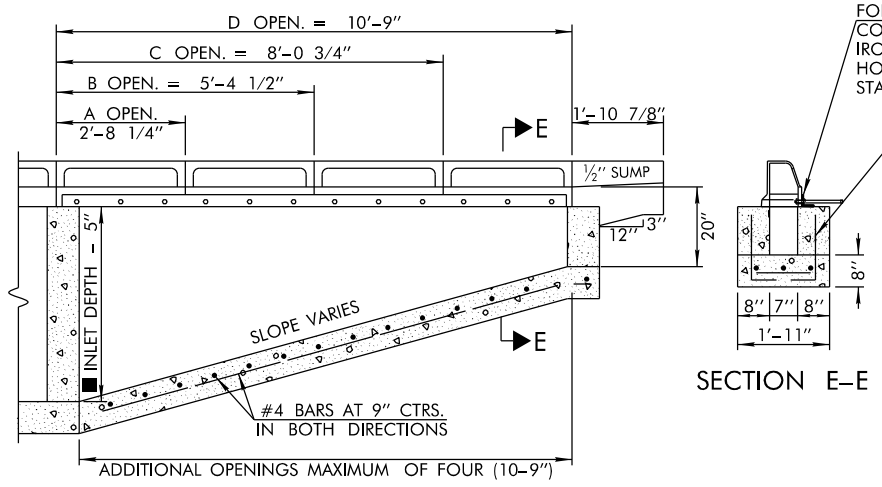

ADDITIONAL CURB OPENINGS

STANDARD INLET DEPTH

INLET W/SMALL JUNCTION BOX	INLET W/LARGE JUNC. BOX
2'-8" FOR 18" R.C.P. & 28 1/2" x 18" REINF. CONC. ARCH PIPE	4'-8" FOR 42" R.C.P.
3'-2" FOR 24" R.C.P. & 36 1/4" x 22 1/2" REINF. CONC. ARCH PIPE	5'-2" FOR 48" R.C.P.
3'-8" FOR 30" R.C.P. & 43 3/4" x 26 5/8" REINF. CONC. ARCH PIPE	
4'-2" FOR 36" R.C.P. & 58 1/2" x 36" REINF. CONC. ARCH PIPE	

FOR DETAIL OF THE CONNECTION ANGLE IRON & CAST IRON HOODS SEE ROADWAY STANDARD C1-2.

STANDARD DEPTH QUANTITIES

INLET DESIGN	CURB OPEN DESIGNATION	CLASS "A" CONCRETE		REINFORCING STEEL		INLET FRAME & GRATE EACH	CAST IRON HOOD EACH	MH FRAME & COVER EACH
		BASE AMOUNT C.Y.	ADD'L CY PER VERT. FT. C.Y.	BASE AMOUNT LBS.	ADD'L CY PER VERT. FT. LBS.			
1		2.84	0.60	244.74	37.41	1	1	1
1	A	3.09	0.54	262.54	35.40	1	2	1
1	B	3.45	0.54	284.79	35.40	1	3	1
1	C	3.81	0.54	302.94	35.40	1	4	1
1	D	4.17	0.54	325.35	35.40	1	5	1
2		3.57	0.65	304.06	42.08	2	2	1
2	A	3.76	0.60	325.86	40.80	2	3	1
2	B	4.15	0.60	348.99	40.80	2	4	1
2	C	4.55	0.60	371.81	40.80	2	5	1
2	D	4.94	0.60	391.72	40.80	2	6	1
3		4.99	1.01	566.27	65.46	4	4	1
3	A	5.47	1.01	591.13	64.01	4	5	1
3	B	5.96	1.01	617.42	64.01	4	6	1
3	C	6.45	1.01	643.30	64.01	4	7	1
3	D	6.95	1.01	665.86	64.01	4	8	1

GENERAL NOTES

1. ALL CONSTRUCTION AND MATERIAL REQUIREMENTS SHALL BE IN ACCORDANCE WITH THE 2019 ODOT STANDARD SPECIFICATIONS.
2. WHEN THE INLET IS BUILT IN NEW CONCRETE PAVEMENT, THE APRON AROUND THE INLET MAY BE BUILT INTEGRAL WITH PAVEMENT, OR MAY BE SEPARATE AND OF THE SIZE AS SHOWN. THE THICKNESS SHALL BE THE SAME AS THE CONCRETE PAVEMENT OR CURB AND GUTTER. IF CONSTRUCTED IN ANY OTHER AREA OR IN EXISTING PAVEMENT, THE APRON AROUND THE INLET SHALL BE BUILT OF P.C. CONCRETE TO A MINIMUM 8 INCH THICKNESS.
3. THERE WILL BE NO DEDUCTION OF PAYMENT FOR CONCRETE CURB AND GUTTER OR P.C. CONCRETE THROUGH THE EXTENTS OF THE CAST IRON CURB HOODS. DEDUCTION WILL BE MADE FOR PAYMENT ON INTEGRAL CURB THROUGH THE EXTENTS OF THE CAST IRON CURB HOODS.
4. STANDARD SSIF-5 FRAMES AND STANDARD CIG-4 GRATES TO BE USED WITH THESE INLETS UNLESS OTHERWISE SPECIFIED. COST OF THESE ITEMS AND HOODS SHALL BE INCLUDED IN THE COST OF INLET.
5. TYPE B & C FRAMES TO BE USED FOR MULTIPLE DOUBLE GRATES. SEE ROADWAY STANDARD SSIF-5 FOR DETAILS.
6. CASTINGS AS SHOWN HERE SHALL BE CAST STEEL, DUCTILE IRON OR GRAY IRON CONFORMING TO SECTION 725 OF THE SPECIFICATIONS.
7. VARIOUS DETAILS NOT SHOWN ON THIS SHEET, SHALL BE CONSTRUCTED AS SHOWN ON ROADWAY STANDARD CI-2, INCLUDING THE SUMP IN THE ROADWAY PAVING APRON, THE CONNECTION OF CAST IRON HOODS TO ANGLE IRON, AND THE CONNECTION OF CAST IRON HOODS TO THE INLET FRAMES.
8. PRICE BID FOR INLET W/JUNCTION BOX, SHALL INCLUDE ALL COST OF MATERIALS AND LABOR ASSOCIATED WITH UNCLASSIFIED EXCAVATION, STRUCTURAL EXCAVATION, CLASS A CONCRETE, REINFORCING STEEL, MANHOLE FRAME & COVER, INLET FRAMES & GRATES, CURB HOODS, CONNECTION ANGLES, CONNECTION BOLTS AND SUPPORT BEAMS.

BASIS OF PAYMENT

ITEM NO.	ITEM	UNIT
611 (G)	INLET W/SMALL JUNCTION BOX (■)	EA.
611 (G)	INLET W/LARGE JUNCTION BOX (■)	EA.
611 (H)	ADD'L DEPTH IN INLET W/SML. JUNCT. BOX (■)	V.F.
611 (H)	ADD'L DEPTH IN INLET W/LRG. JUNCT. BOX (■)	V.F.

■ INLET DESIGN AND CURB DESIGNATION SHALL BE SPECIFIED. I.E. DESIGN 1(B) or 2(STD.)
 ■ THE INLET DESIGN NO. SHALL BE SPECIFIED, I.E. DESIGN 1, 2 OR 3.

DESIGN	-	-	PHASE 4	OKLAHOMA COUNTY
DRAWN	-	-	DETAIL OF CURB INLET W/ JUNCTION BOX	
CHECKED	-	-		
APPROVED	-	-		
SQUAD	POE		STATE JOB NO. 09032108	SHEET NO. R110

* NOTE: THE C OF PIER NO. 7 IS ON A CHORD BETWEEN THE INTERSECT POINTS OF RAMP "B" AND RAMP "M" WITH CURVE "C-2" OF PROP. C OF I-240. THE ANGLE BETWEEN THE TANGENT OF RAMP "B" AND THE C OF PIER IS 69°20'15.5". (THE ANGLE BETWEEN THE TANGENT OF C-240 AND TANGENT OF RAMP "B" IS 69°35'01.87")

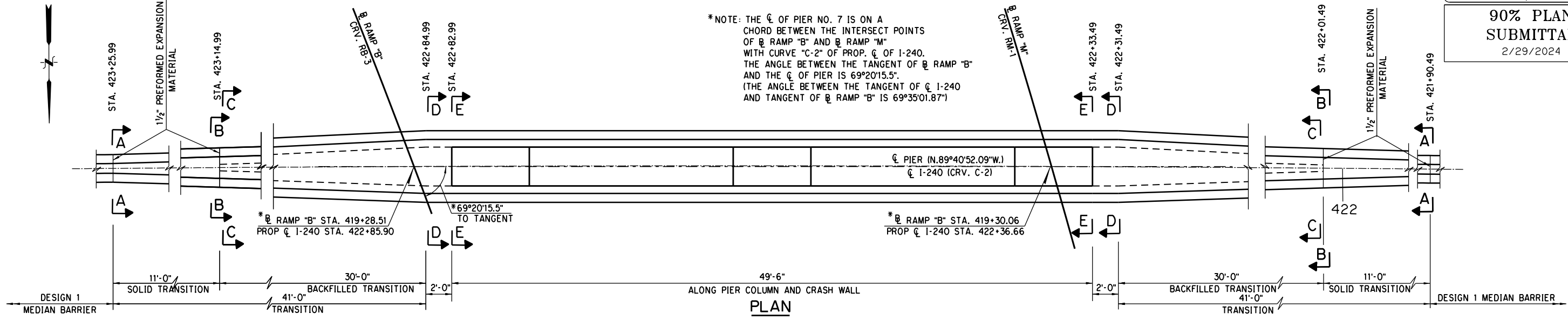

PLAN
EAST - WEST TRANSITIONS

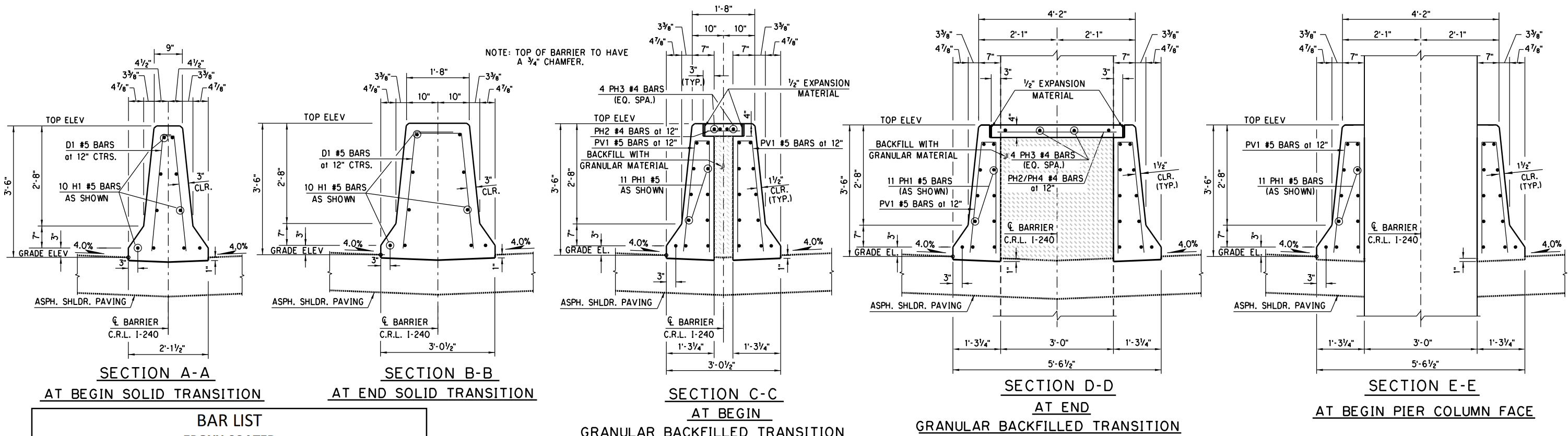

BAR LIST
EPOXY COATED

SOLID TRANSITION						
MARK	NO.	SIZE	FORM	SPACING	LENGTH	LENGTH VARIATION
D1	48	#5	BNT.	12" C/C	3'-11 1/2" AVG.	3'-6" TO 4'-5"
H1	20	#5	STR.	AS SHOWN	10'-8"	--
GRANULAR BACKFILLED TRANSITION						
MARK	NO.	SIZE	FORM	SPACING	LENGTH	LENGTH VARIATION
PV1	228	#5	BNT.	12" c/c	6'-8"	--
PH1	22	#5	STR.	AS SHOWN	117'-6"	--
PH2	62	#4	STR.	12" C/C	1'-11" AVG.	8" TO 3'-2"
PH3	8	#4	STR.	EQ. SPA.	31'-6"	--
PH4	4	#4	STR.	EQ. SPA.	3'-2"	--

① LENGTH INCLUDES LAP:
PH1 - 2 at 2'-0"
(STAGGER ALL LAPS)

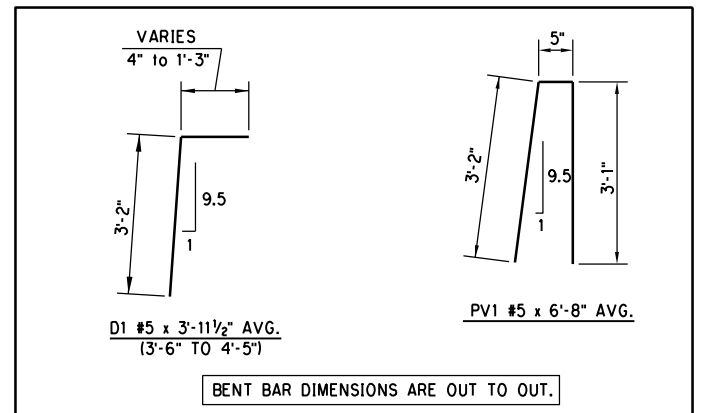

QUANTITIES
(FOR INFORMATION ONLY)

ITEM	UNIT	TOTAL
CLASS A CONCRETE	C.Y.	30.30
EPOXY COATED REINFORCING STEEL	LB.	4,960.00

NOTE: ALL COST OF GRANULAR BACKFILL TO BE INCLUDED IN OTHER ITEMS OF WORK.

BARRIER ELEVATION SCHEDULE

STATION	TOP	GRADE
421+90.49	1293.08	1289.58
422+01.49	1293.47	1289.97
422+31.49	1294.50	1291.00
422+33.49	1294.56	1291.06
422+82.99	1289.09	1292.59
422+84.99	1296.15	1292.65
423+14.99	1296.97	1293.47
423+25.99	1297.26	1293.76

PHASE 4 BRIDGE "B" OKLAHOMA COUNTY
RAMP "B" AT I-35 & I-240 INTERCHANGE
PIER PROTECTION AND BARRIER TRANSITION DETAILS
(BRIDGE "B" PIER 7)
STATE JOB NO. 09032(08) SHEET NO. R111

DESIGN	
DRAWN	
CHECKED	
APPROVED	
SQUAD	POE

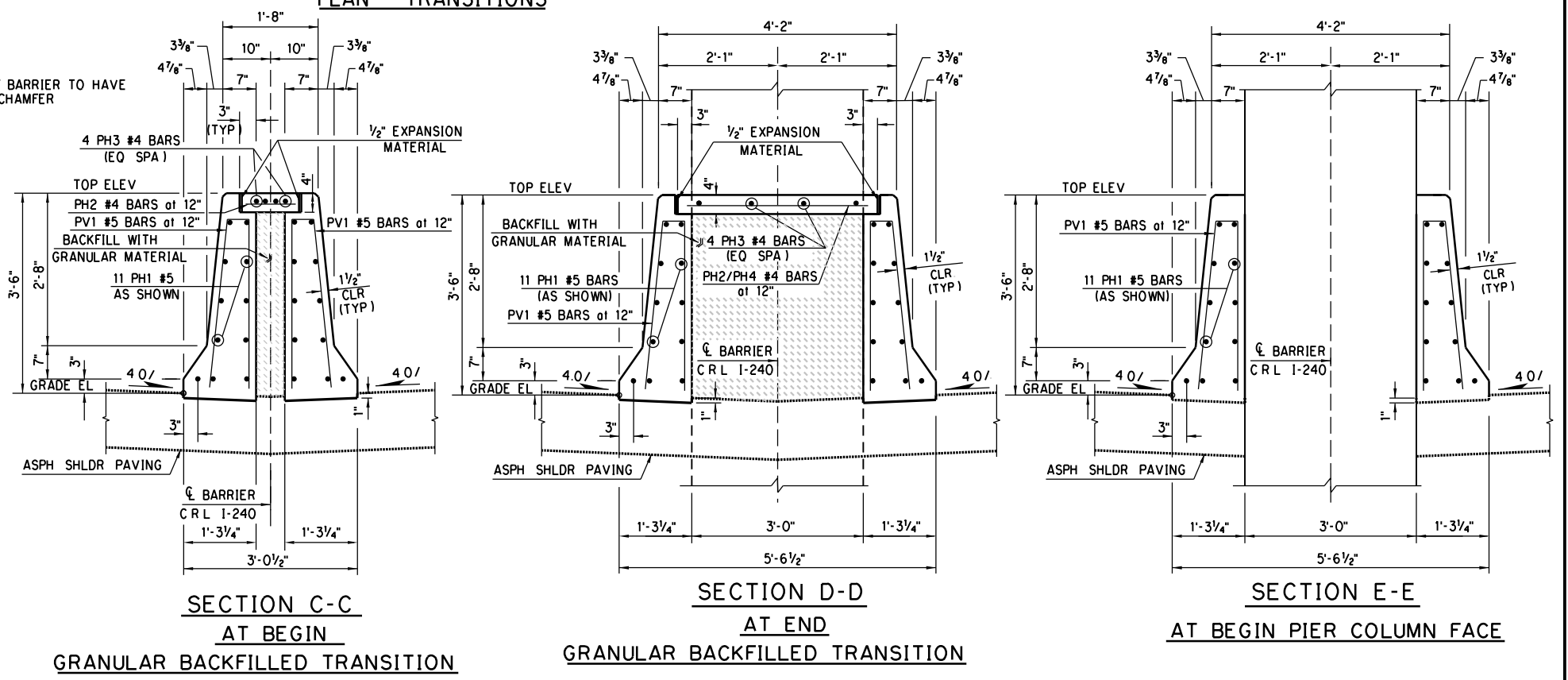
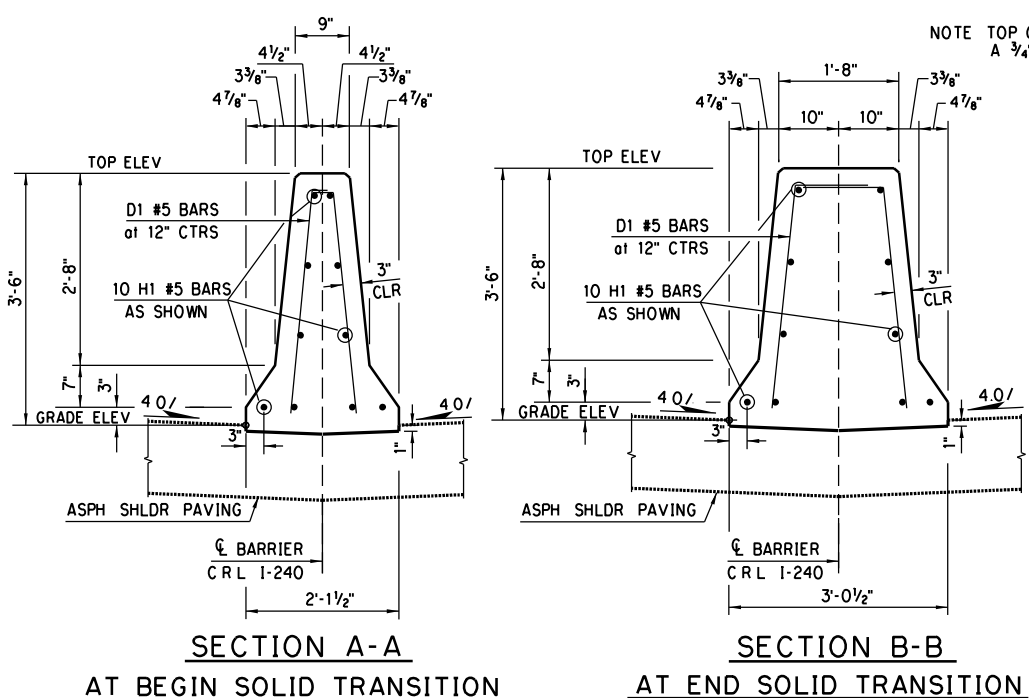
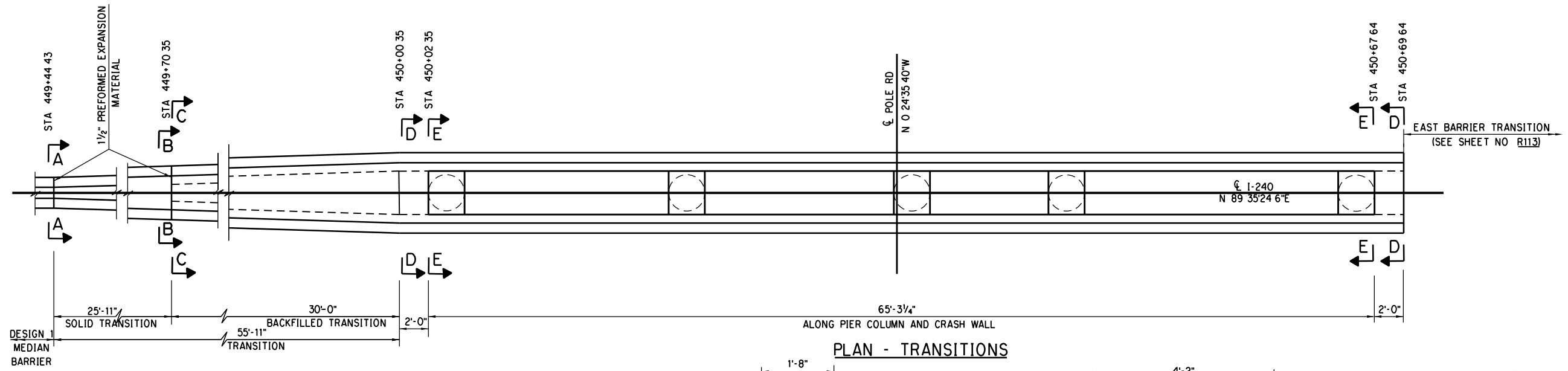

BAR LIST						
EPOXY COATED						
SOLID TRANSITION						
MARK	NO.	SIZE	FORM	SPACING	LENGTH	LENGTH VARIATION
D1	48	#5	BNT.	12" C/C	3'-11 1/2" AVG.	3'-6" TO 4'-5"
H1	20	#5	STR.	AS SHOWN	10'-8"	--
GRANULAR BACKFILLED TRANSITION						
MARK	NO.	SIZE	FORM	SPACING	LENGTH	LENGTH VARIATION
PV1	260	#5	BNT.	12" c/c	6'-8"	--
PH1	22	#5	STR.	AS SHOWN	134'-11"	--
PH2	62	#4	STR.	12" C/C	1'-11" AVG.	8" TO 3'-2"
PH3	8	#4	STR.	EQ. SPA.	31'-6"	--
PH4	4	#4	STR.	EQ. SPA.	3'-2"	--

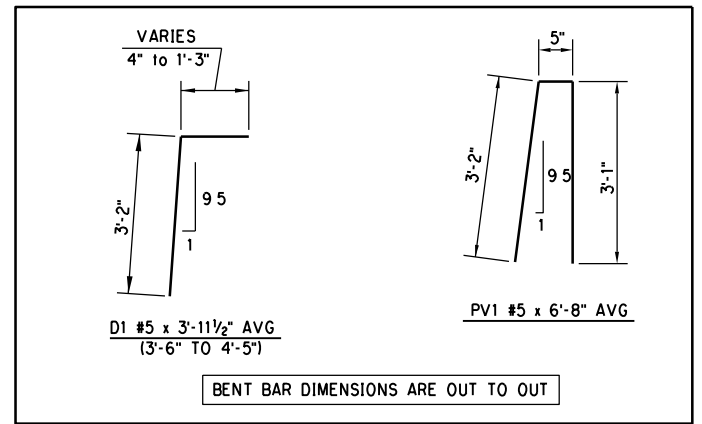

QUANTITIES		
(FOR INFORMATION ONLY)		
ITEM	UNIT	TOTAL
CLASS A CONCRETE	C.Y.	33.70
EPOXY COATED REINFORCING STEEL	LB.	5,590.00

NOTE: ALL COST OF GRANULAR BACKFILL TO BE INCLUDED IN OTHER ITEMS OF WORK.

BARRIER ELEVATION SCHEDULE		
STATION	TOP	GRADE
449+44.43	1283.70	1280.20
449+70.35	1282.99	1279.49
450+00.35	1282.18	1278.68
450+02.35	1282.13	1278.63
450+67.64	1280.36	1276.86
450+69.34	1280.31	1276.81
450+99.64	1279.51	1276.01
451+25.58	1278.80	1275.30

PHASE 4 BRIDGE "F" OKLAHOMA COUNTY POLE ROAD OVER I-240

PIER PROTECTION AND BARRIER TRANSITION DETAILS

STATE JOB NO. 09032(08) SHEET NO. R112

DESIGN	
DRAWN	
CHECKED	
APPROVED	
SQUAD	POE

3/11/2024 5:28:55 PM H:\PROJECTS\2789_Crossroads\Phase 4\Bridges\Drawings\Ph4 Bridges\Bridges\F Pier Protection\0903206 P4 Bridge F Pier Protection.dgn

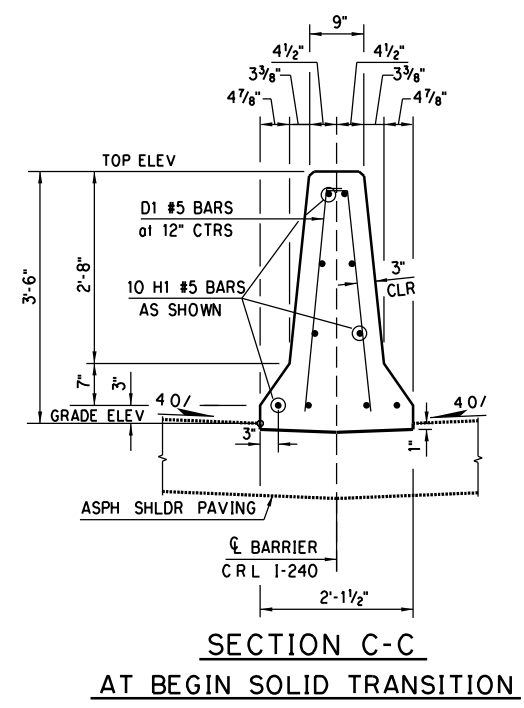
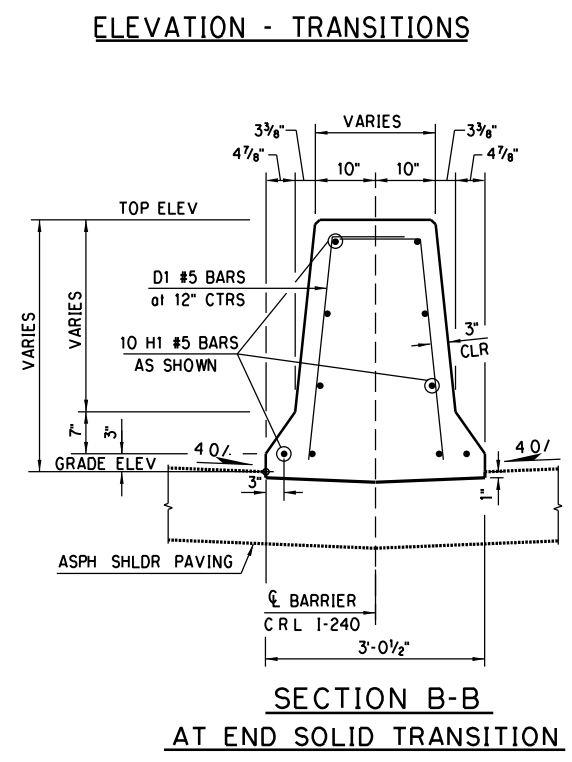
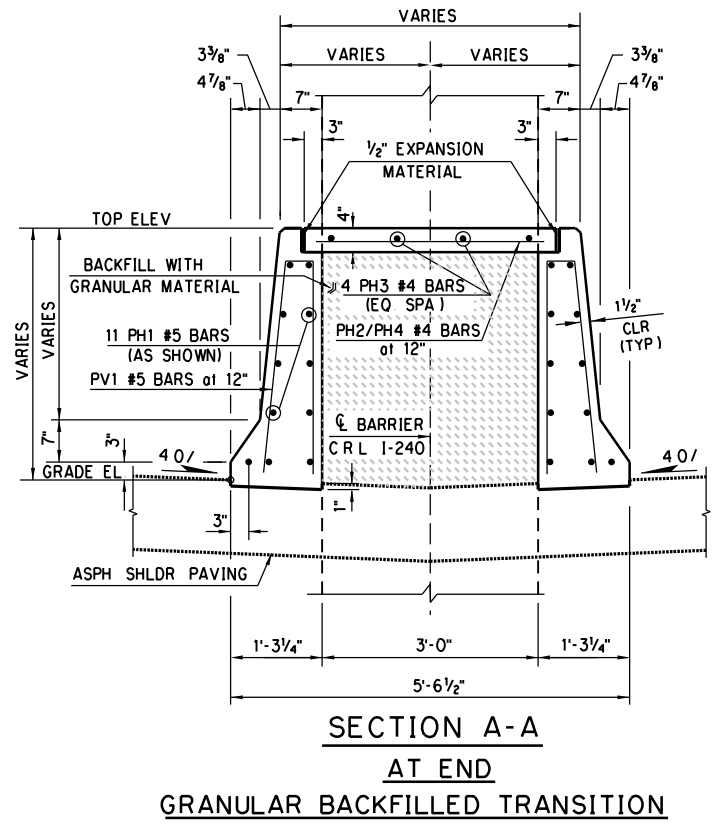
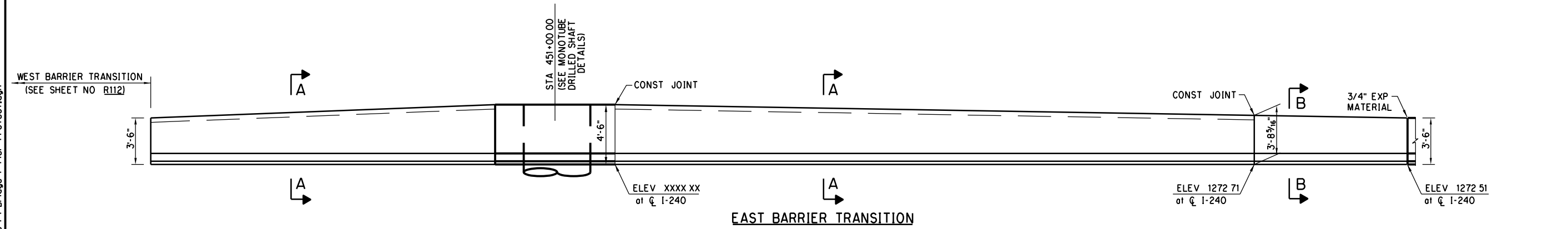
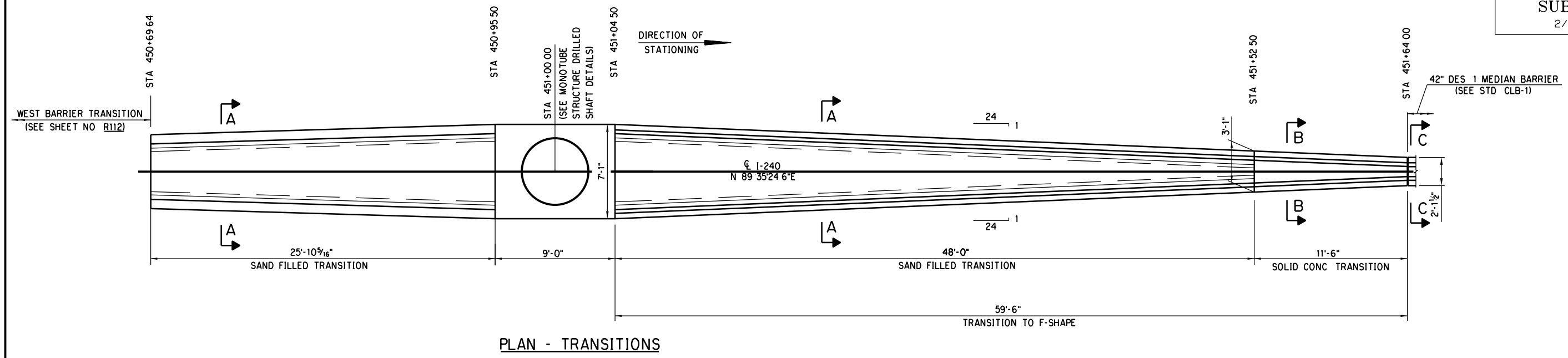

DESIGN		PHASE 4	OKLAHOMA COUNTY
DRAWN		BRIDGE "F"	POLE ROAD OVER I-240
CHECKED		PIER PROTECTION AND BARRIER TRANSITION DETAILS	
APPROVED			
SQUAD	POE		
		STATE JOB NO. 09032(08)	SHEET NO. R113

3/11/2024 5:29:46 PM H:\PROJECTS\2789_Crossroads_Phase 4\Bridges\Drawings\Pier Protection\0903206 P4 Bridge F Pier Protection.dgn

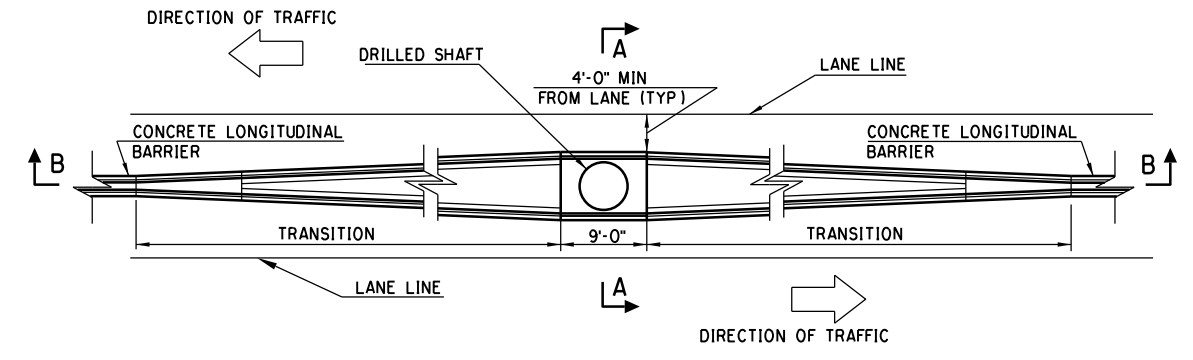
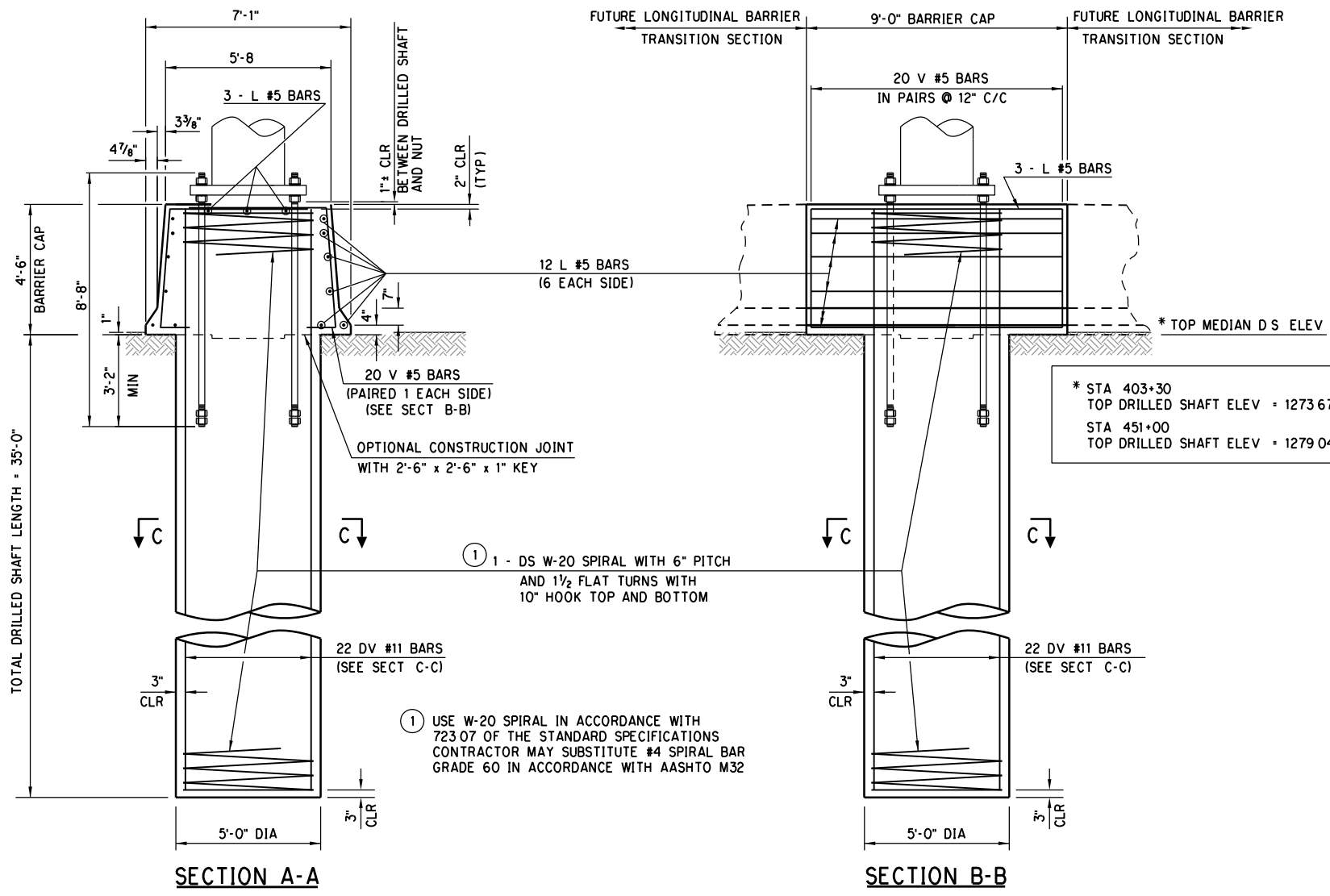

CONCRETE LONGITUDINAL BARRIER DETAIL (PLAN VIEW)

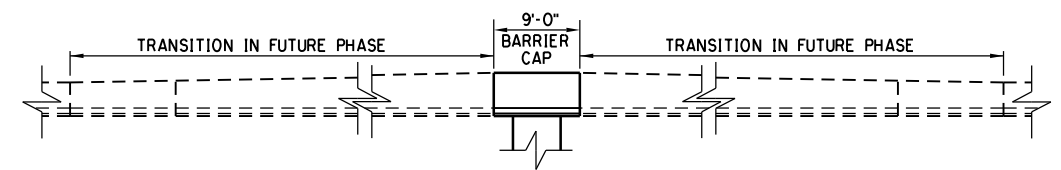

CONCRETE LONGITUDINAL BARRIER DETAIL (ELEVATION VIEW)

DRILLED SHAFT NOTES

MATERIAL PROPERTIES
 CLASS 'AA' CONCRETE = 4,000 PSI
 REINFORCING STEEL = 60,000 PSI

THE DRILLED SHAFT FOR THE MONOTUBE SIGN STRUCTURE HAS BEEN DESIGNED FOR THE FOLLOWING PROPERTIES

- COHESIVE SOIL
 UNIT WEIGHT = 120 PCF
 COHESION = 1000 PSF
- GRANULAR SOIL
 UNIT WEIGHT = 120 PCF
 INTERNAL FRICTION ANGLE = 28 DEGREES

IF SITE CONDITIONS ARE ENCOUNTERED THAT DIFFER FROM THOSE SPECIFIED ABOVE, THE ENGINEER SHALL BE CONTACTED SUCH CONDITIONS ARE, BUT NOT LIMITED TO, AS FOLLOWS

- SOIL HAS HIGH ORGANIC CONTENT OR CONSISTS OF SATURATED SILT AND CLAY
- THE SITE WON'T SUPPORT THE WEIGHT OF THE DRILLING RIG
- ROCK IS ENCOUNTERED (IF SHALE IS ENCOUNTERED AT LESS THAN 10' FROM TOP OF SHAFTS, USE LENGTH SHOWN ON THIS SHEET)

DRILLED SHAFTS SHALL BE CONSTRUCTED ACCORDING TO THE OKLAHOMA DEPARTMENT OF TRANSPORTATION'S STANDARD SPECIFICATIONS FOR HIGHWAY CONSTRUCTION AND ASSOCIATED SPECIAL PROVISIONS THE USE OF THE "DOUBLE CASING METHOD" IS NOT ALLOWED FOR THIS DESIGN

THE CONTRACTOR SHALL BE RESPONSIBLE FOR CONFIRMING THAT THE LOCATION AND ELEVATION OF THE DRILLED SHAFT ARE AS REQUIRED IN THE PLANS THE CONTRACTOR SHALL COORDINATE WITH THE MONOTUBE SUPPLIER TO ENSURE THAT THE ORIENTATION OF THE ANCHOR BOLTS IN THE DRILLED SHAFT ALLOW FOR PROPER ALIGNMENT OF ALL BASE PLATES AND FLANGES UPON FINAL INSTALLATION

QUANTITIES - BARRIER CAP

ITEM	UNIT	TOTAL
CLASS A CONCRETE	C.Y.	12.5
REINFORCING STEEL	LB.	350

BAR LIST - BARRIER CAP
(INCLUDED IN CONTRACT UNIT PRICE OF DRILLED SHAFT)

MARK	NO.	SIZE	FORM	SPACING	LENGTH
L	15	#5	STR.	AS SHOWN	8'-8"
V	20	#5	BENT	12" C/C	9'-11"

BAR LIST - DRILLED SHAFT
(INCLUDED IN CONTRACT UNIT PRICE OF DRILLED SHAFT)

MARK	NO.	SIZE	FORM	SPACING	LENGTH
DS	1	W-20	BENT	6" PITCH	1156'-6"
DV	22	#11	STR.	EQUAL	39'-1"

BASIS OF PAYMENT

ITEM NO.	ITEM	UNIT	TOTAL
② 516(A)	DRILLED SHAFTS 60" DIAMETER	L.F.	35

② ALL COSTS OF CONCRETE AND REINFORCING IN DRILLED SHAFTS SHALL BE INCLUDED IN THE PRICE BID FOR "DRILLED SHAFTS 60" DIAMETER".

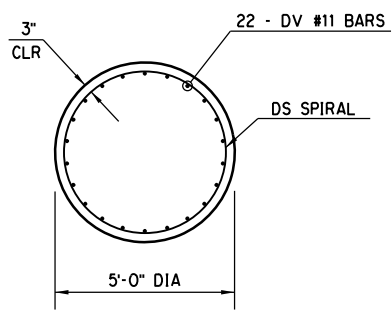

SECTION C-C

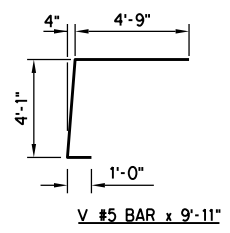

3/11/2024 5:35:20 PM H:\PROJECTS\2789_CrossRoads_Phase 4 Bridge Drawings\Ph4 Bridges\Median Barrier and Drilled Shaft\0903206 P4 Median Barrier and Drilled Shaft details.dgn

PHASE 4

DESIGN	
DRAWN	
CHECKED	
APPROVED	
SQUAD	POE

MEDIAN BARRIER AND DRILLED SHAFT DETAILS
 I-240 MONOTUBE STRUCTURE
 (SHEET 1 OF 2)
 STATE JOB NO. 09032(07) SHEET NO. R114

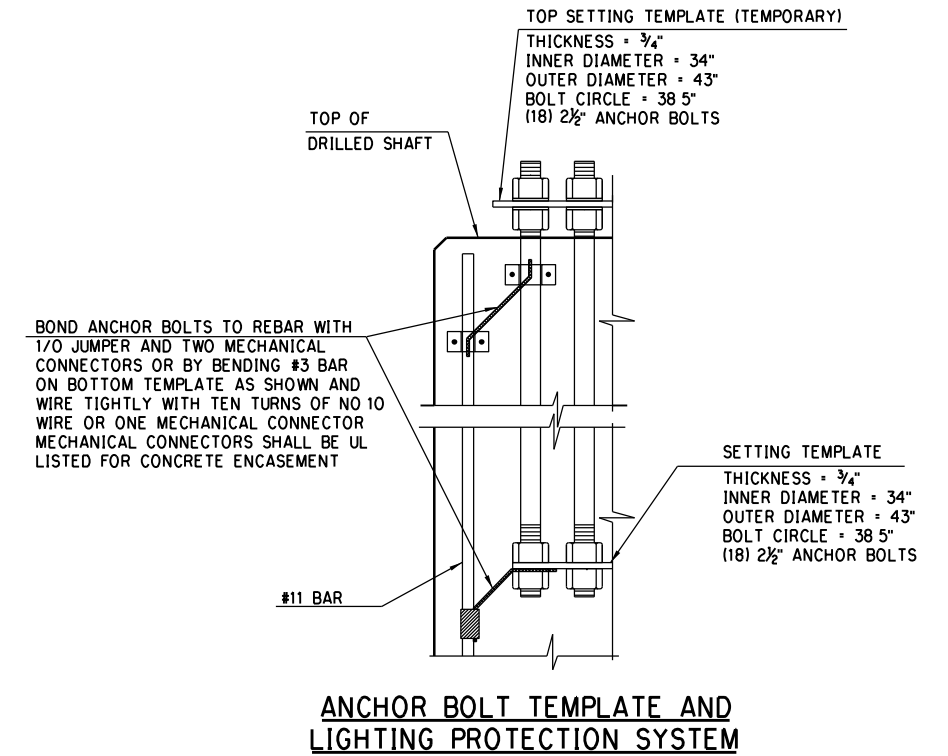
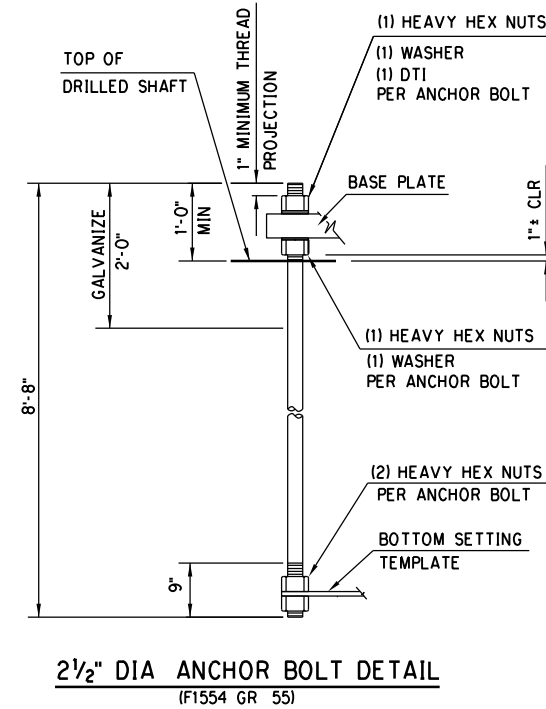
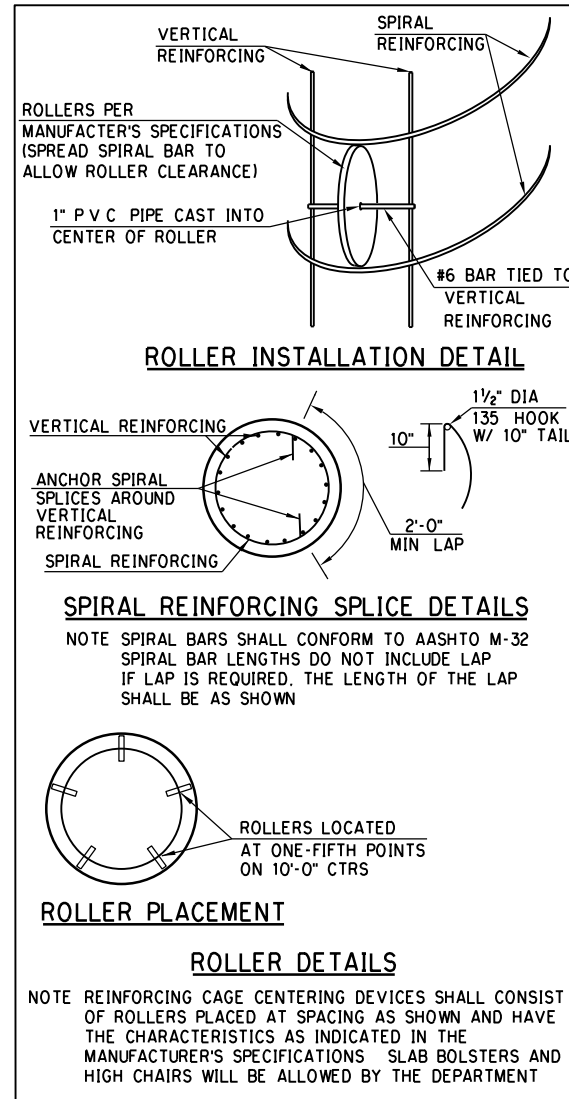

3/11/2024 5:35:36 PM H:\PROJECTS\2789_CrossRoads_Phase 4\Bridges\Drawings\Ph4 Bridges\Median Barrier and Drilled Shaft\0903206 P4 Median Barrier and Drilled shaft details.dgn

DESIGN	
DRAWN	
CHECKED	
APPROVED	
SQUAD	POE

PHASE 4

MEDIAN BARRIER AND DRILLED SHAFT DETAILS
I-240 MONOTUBE STRUCTURE
(SHEET 2 OF 2)

STATE JOB NO. 09032(07) SHEET NO. R115

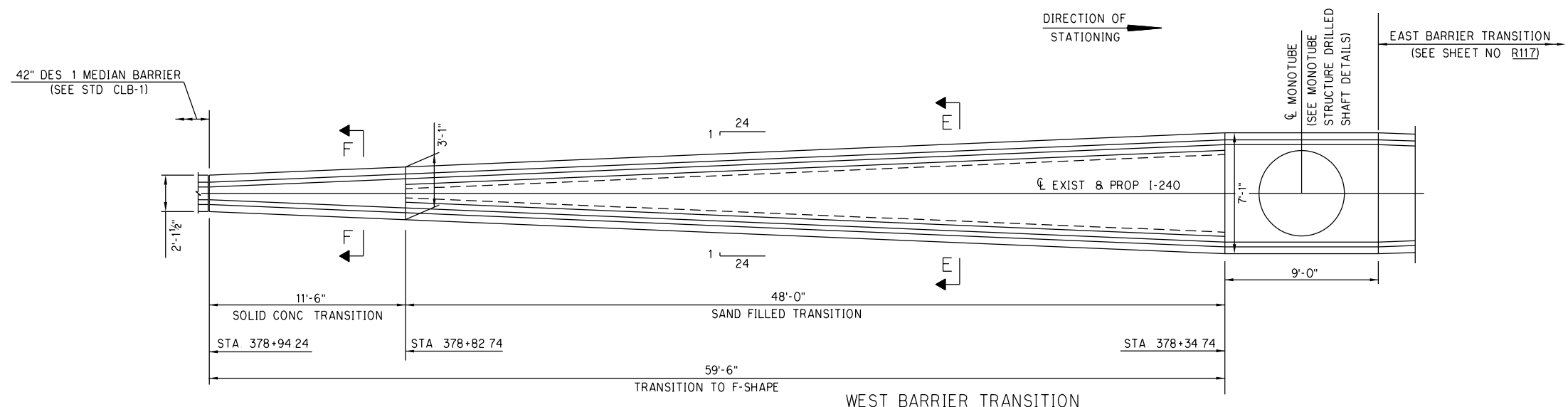

PLAN - TRANSITIONS

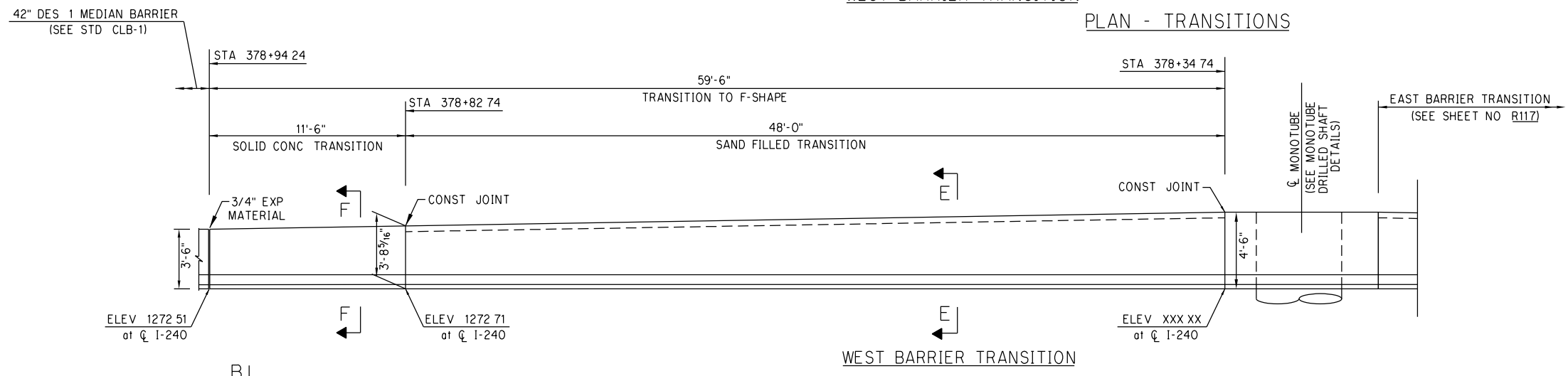

ELEVATION - TRANSITION

CL MONOTUBE STATION		
403+30.00	CL I-240	
405+55.00	CL I-240	
413+90.00	CL I-240	

QUANTITIES		
ITEM	UNIT	TOTAL
* CLASS A CONCRETE	C Y	19.40

LIGHT POLE FOOTING QUANTITIES NOT INCLUDED HERE. SEE SPECIAL MEDIAN BARRIER LIGHT POLE FOOTING AND SUPPORT DETAILS.
* NOTE THE COST OF REINFORCING STEEL, SAND BACKFILL, PREMOLDED EXPANSION MATERIAL AND ALL OTHER MATERIALS, LABOR AND INCIDENTALS NECESSARY TO COMPLETE THE WORK AS SHOWN SHALL BE INCLUDED IN THE PRICE BID PER C Y OF "CLASS A CONCRETE"

TO BE VERIFIED IN FIELD

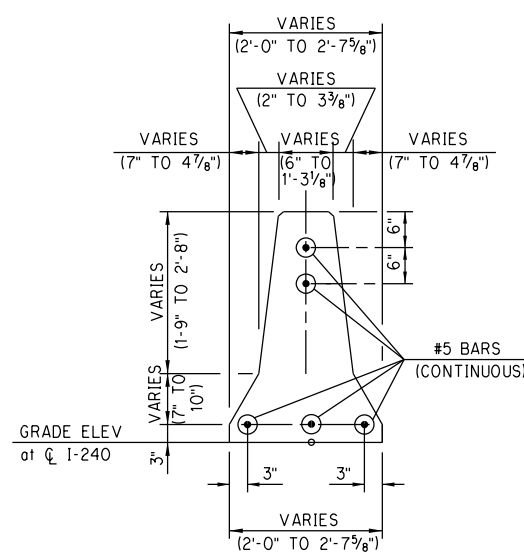

SECTION A-A

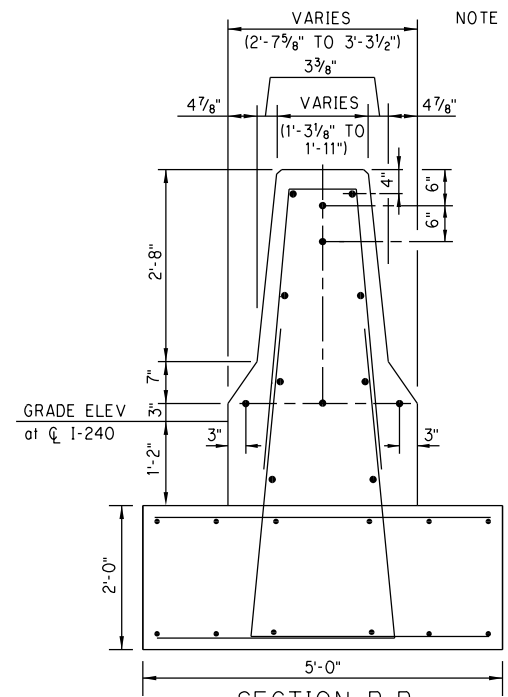

SECTION B-B

NOTE SEE SHEET 90 FOR LIGHT POLE NO. 1 SUPPORT AND REINFORCING DETAILS

NOTE TOP OF BARRIER TO HAVE A 3/4" CHAMFER

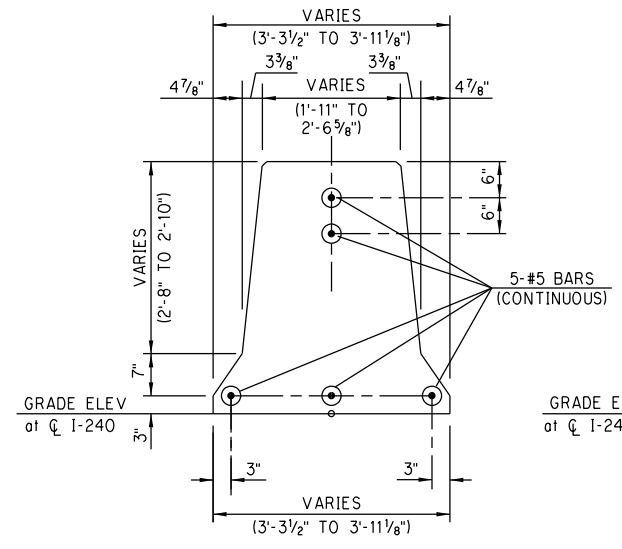

SECTION C-C

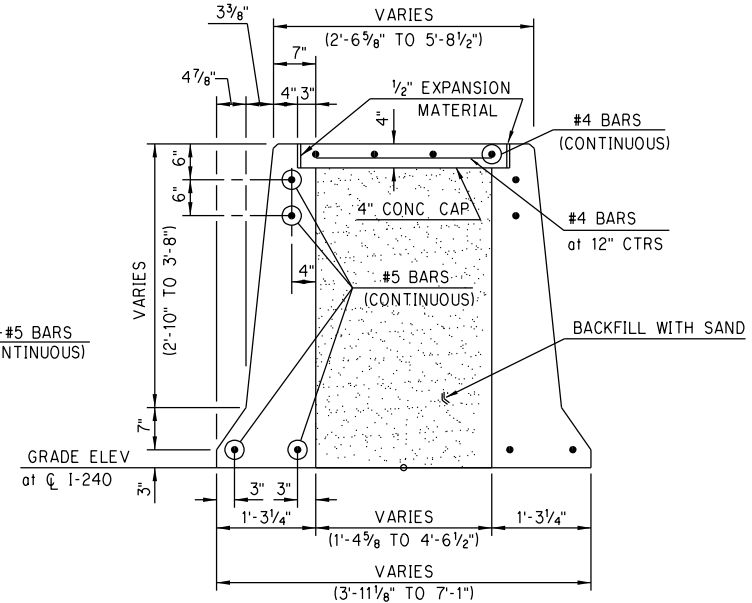

SECTION D-D
(TYPICAL THRU SAND FILLED TRANSITION)

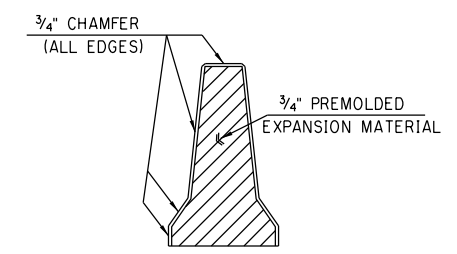

AT EXISTING MEDIAN BARRIER
DETAIL OF EXPANSION JOINT
(NOTE CLEAR ALL REINFORCING STEEL 2" FROM JOINTS)

NOTE FOR GENERAL NOTES AND ADDITIONAL INFORMATION, REFER TO STD CLB-1-2

Design	
Drawn	
Checked	
Approved	
Squad	POE

OKLAHOMA COUNTY
MEDIAN BARRIER TRANSITION
DETAILS
I-240 & SANTA FE AVE
(SHEET 1 OF 2)
State Job No. 09032108 Sheet No. R116

3/1/2024 5:42:17 PM H:\PROJECTS\2789_CrossRoads_Phase_4\Bridges\Drawings\Ph4_Bridges\Median Barrier and Drilled Shaft\0903206_P4_Median Barrier_Transition_Details.dgn

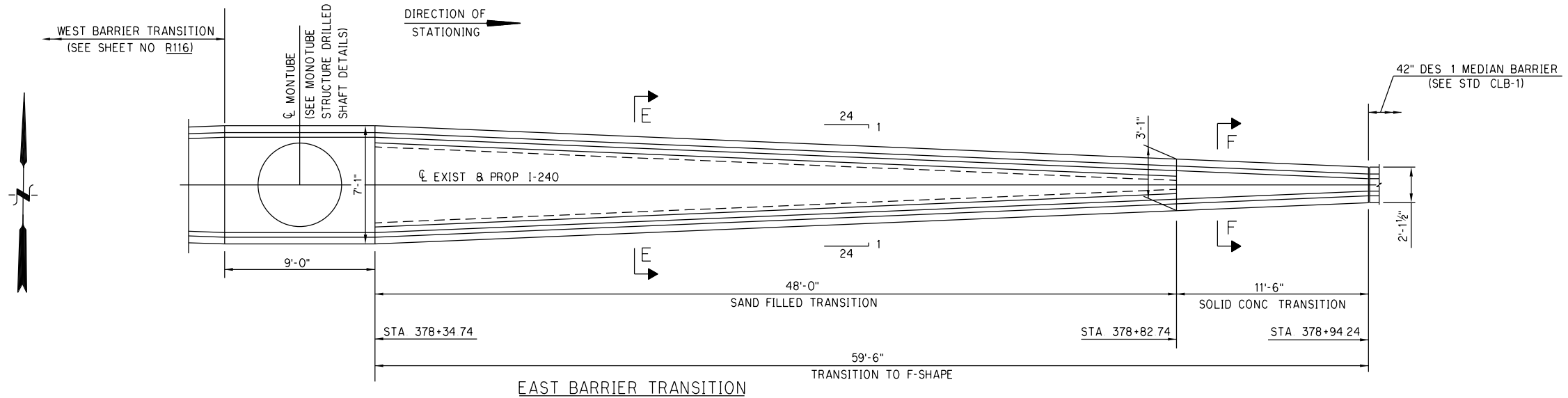

PLAN - TRANSITIONS

CL MONOTUBE STATION	
403+30.00	CL I-240
405+55.00	CL I-240
413+90.00	CL I-240

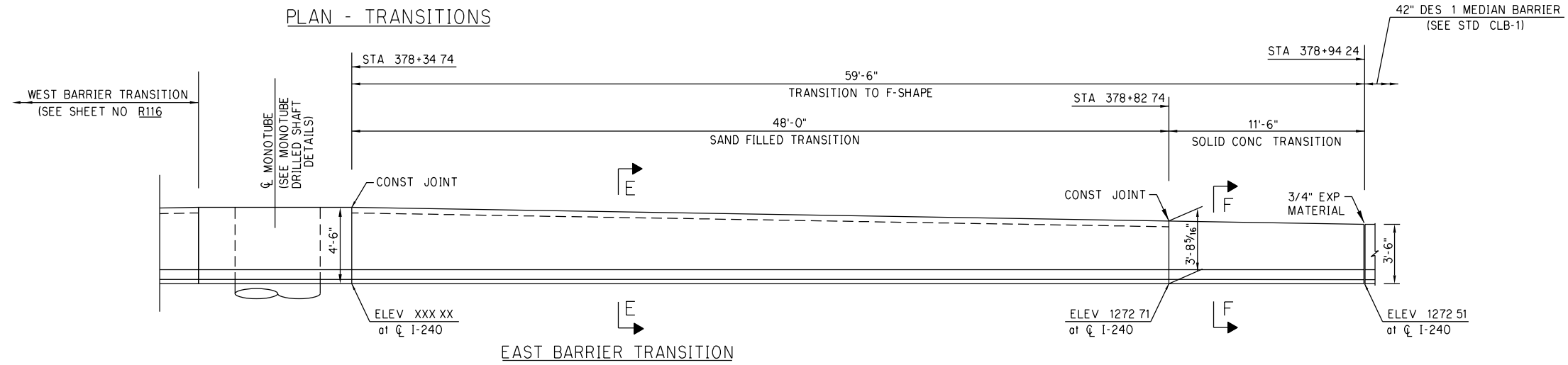

ELEVATION - TRANSITIONS

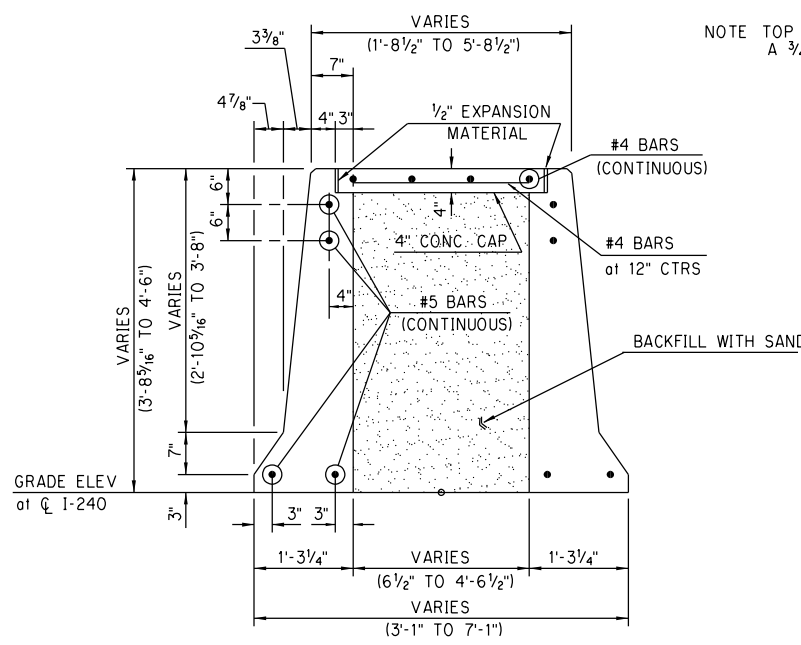

SECTION E-E
(TYPICAL THRU SAND FILLED TRANSITION)

NOTE TOP OF BARRIER TO HAVE A 3/4" CHAMFER

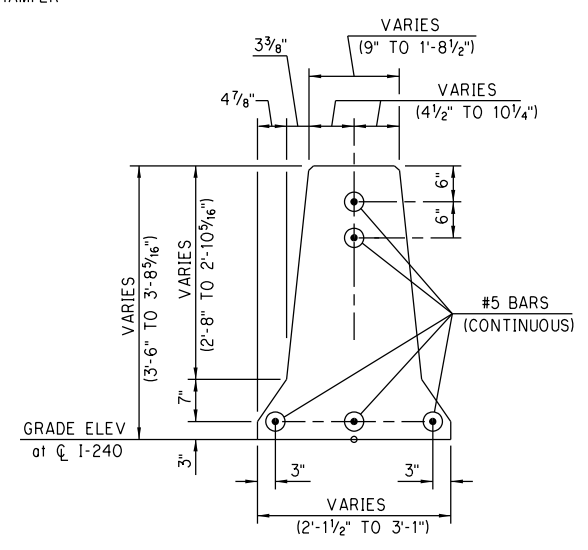

SECTION F-F
(TYPICAL THRU SOLID TRANSITION IN EAST BARRIER)

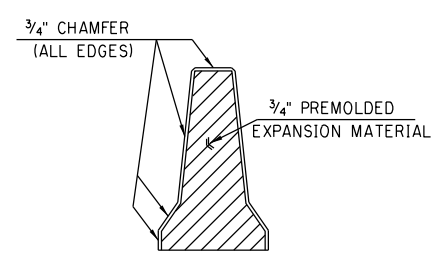

AT STANDARD MEDIAN BARRIER
DETAIL OF EXPANSION JOINT
(NOTE CLEAR ALL REINFORCING STEEL 2" FROM JOINTS)

QUANTITIES		
ITEM	UNIT	TOTAL
* CLASS A CONCRETE	C Y	15.90

*NOTE THE COST OF REINFORCING STEEL, SAND BACKFILL, PREMOLDED EXPANSION MATERIAL AND ALL OTHER MATERIALS, LABOR AND INCIDENTALS NECESSARY TO COMPLETE THE WORK AS SHOWN SHALL BE INCLUDED IN THE PRICE BID PER C Y OF "CLASS A CONCRETE"

NOTE FOR GENERAL NOTES AND ADDITIONAL INFORMATION, REFER TO STD CLB-1-2

Design	
Drawn	
Checked	
Approved	
Squad	POE

OKLAHOMA COUNTY
MEDIAN BARRIER TRANSITION
DETAILS
I-240 & SANTA FE AVE
(SHEET 2 OF 2)
State Job No. 09032(08) Sheet No. R117

3/11/2024 5:42:45 PM H:\PROJECTS\2789_CrossRoads_Phase_4\Bridges\Drawings\Ph4_Bridges\Median Barrier and Drilled Shaft\0903206_P4_Median Barrier_Transition_Details.dgn

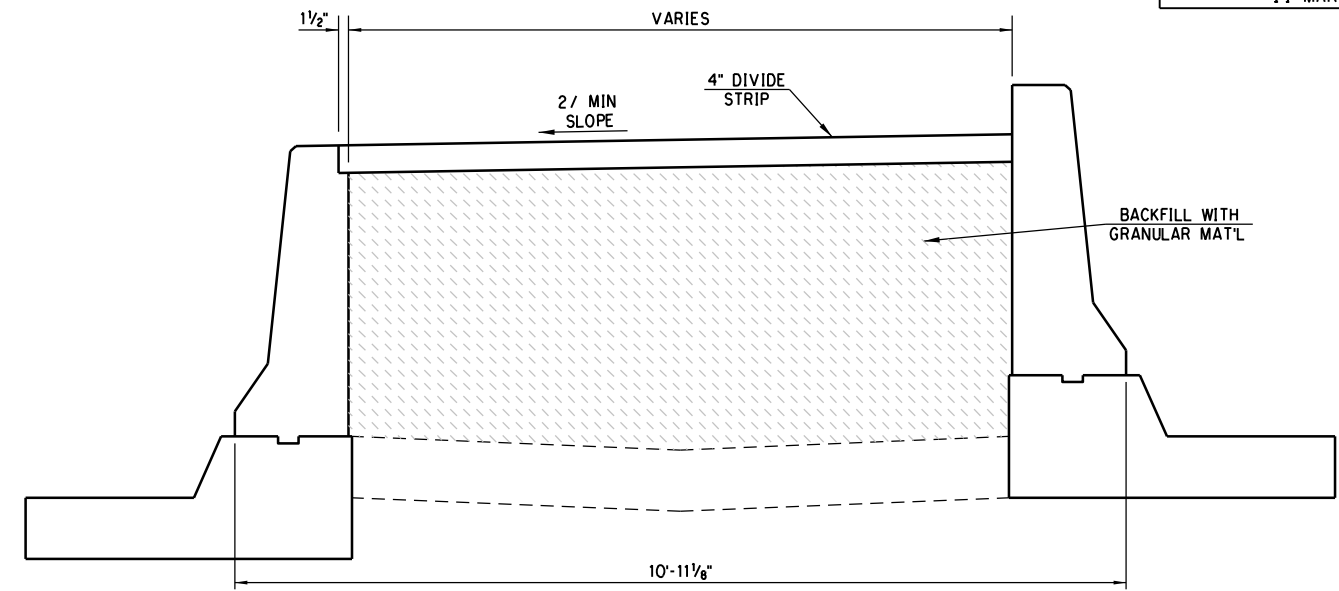
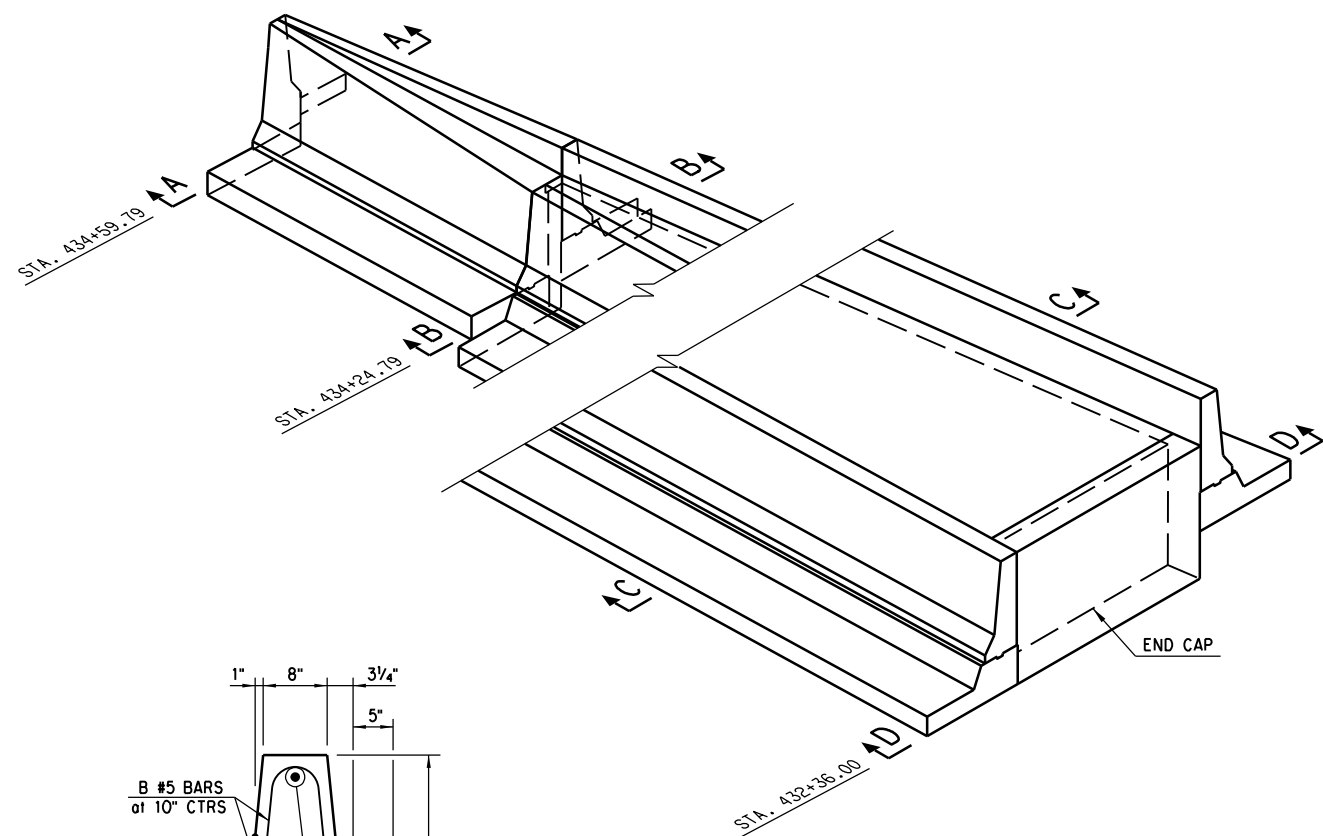

SECTION C-C
GRANULAR BACKFILLED TRANSITION

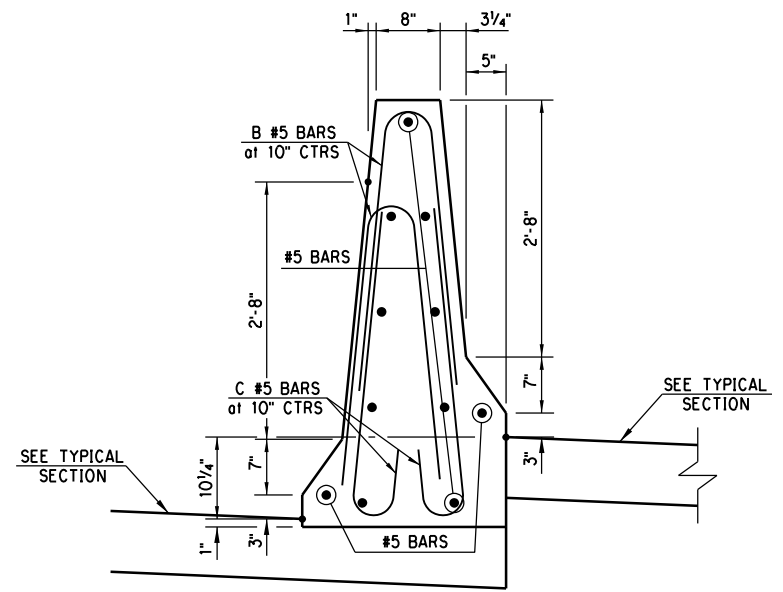

SECTION A-A

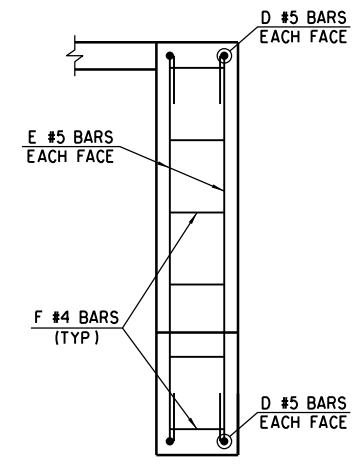

SECTION E-E
END WALL

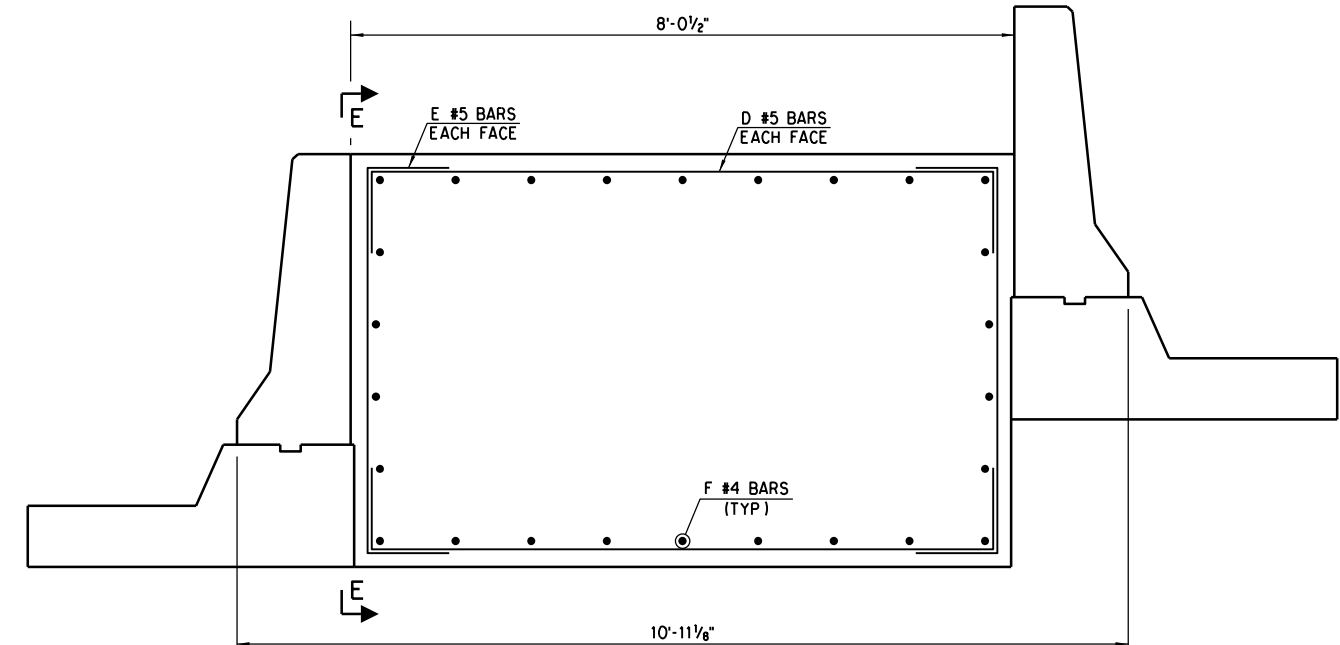

SECTION D-D
END WALL

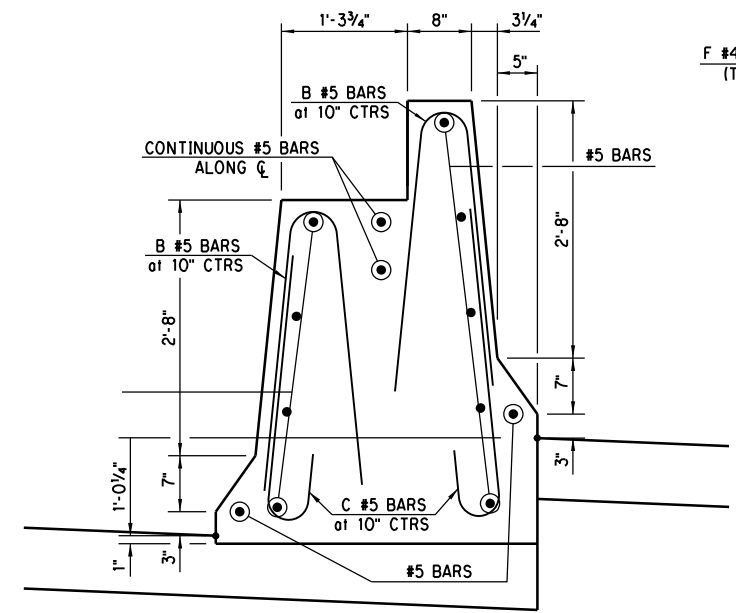

SECTION B-B

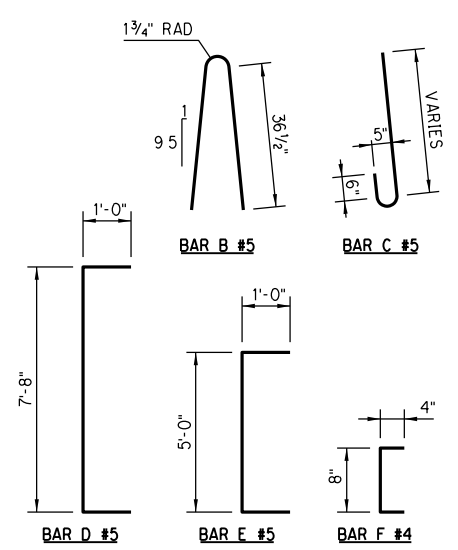

- NOTES
- ALL VERTICAL STIRRUP AND HORIZONTAL REINFORCING STEEL SHALL OVERLAP A MINIMUM OF 24" AT SPLICES AND HAVE 2" CLEARANCE (MIN) FROM REINFORCING STEEL TO NEAR FACE
 - MEDIAN BARRIER SPECIAL TRANSITION SECTION IS USED TO TRANSITION DESIGN TO F-SHAPED PARAPET WITH MOMENT SLAB REFER TO STANDARD DETAIL CLB-1 DESIGN 1-A FOR ADDITIONAL INFORMATION

QUANTITIES (FOR INFORMATION ONLY)			
ITEM	UNIT	MEDIAN TRANSITION	END WALL
CLASS A CONCRETE	C.Y.	59	1.7
EPOXY COATED REINFORCING STEEL	LB.	1390	70

DESIGN	-	-	PHASE 4	TULSA COUNTY
DRAWN	-	-		
CHECKED	-	-		
APPROVED	-	-		
SQUAD	POE			

**MEDIAN BARRIER
SPECIAL TRANSITION DETAILS**

STATE JOB NO. 12345(04) SHEET NO. R118

SUMMARY OF RETAINING WALL QUANTITIES
(FOR INFORMATION PURPOSE ONLY)

ITEM		UNIT	M.S.E. WALL D2	M.S.E. WALL F	M.S.E. WALL G	M.S.E. WALL H	SOIL NAIL WALL I	TOTAL
PAY ITEMS	TEMPORARY EARTH RETAINAGE	L.SUM	1.00	--	--	--	--	1.00
	CLASS C CONCRETE	C.Y.	13.70	--	--	--	--	13.70
	CONCRETE RAIL (TR-4)	L.F.	--	--	--	--	984.00	984.00
	MSE RETAINING WALL	S.Y.	274.00	180.40	44.90	437.00	--	936.30
	SOIL NAIL RETAINING WALL	S.Y.	--	--	--	--	872.60	872.60
	(SP) GRAFFITI TREATMENT	S.F.	1,936.00	1,264.00	336.00	2,848.00	5,887.00	12,271.00
	WATER REPELLENT (VISUALLY INSPECTED)	S.Y.	--	--	--	--	451.00	451.00
	FENCE-STYLE CLF (6' HIGH CLASS A)	L.F.	--	--	--	--	984.00	984.00
	1 1/2" CONC. SURFACE TREATMENT	S.F.	1,936.00	1,264.00	336.00	2,848.00	5,887.00	12,271.00
NON-PAY ITEMS	6" PERFORATED PIPE UNDERDRAIN ROUND	L.F.	265.17	179.51	34.30	542.76	--	1,021.74
	6" NON-PERF. PIPE UNDERDRAIN RND.	L.F.	20.00	20.00	20.00	20.00	--	80.00

NOTE: RETAINING WALLS: GRAFFITI TREATMENT AND SURFACE TREATMENT ARE MEASURED 2' ABOVE THE BOTTOM OF WALLS TO TOPS OF RETAINING WALLS.

INDEX OF SHEETS

SHT. NO.	DESCRIPTION
RW01	RETAINING WALL LOCATION MAP & SUMMARY OF QUANTITIES
RW02	M.S.E. RETAINING WALL 'D2' PLAN & ELEVATION
RW03	FOUNDATION REPORT - RETAINING WALL 'D2'
RW04	M.S.E. RETAINING WALL 'F' PLAN & ELEVATION
RW05	FOUNDATION REPORT - RETAINING WALL 'F'
RW06	M.S.E. RETAINING WALL 'G' PLAN & ELEVATION
RW07	FOUNDATION REPORT - RETAINING WALL 'G'
RW08	M.S.E. RETAINING WALL 'H' PLAN & ELEVATION
RW09-RW11	FOUNDATION REPORT - RETAINING WALL 'H'
RW12	M.S.E. RETAINING WALL NOTES
RW13	M.S.E. RETAINING WALL DETAILS
RW14	SOIL NAIL RETAINING WALL 'I' PLAN & ELEVATION
RW15-RW19	FOUNDATION REPORT - RETAINING WALL 'I'
RW20	SOIL NAIL RETAINING WALL 'I' SPECIFICATIONS
RW21	SOIL NAIL RETAINING WALL 'I' HORIZONTAL ALIGNMENT LAYOUT
RW22-RW25	SOIL NAIL RETAINING WALL 'I' LAYOUT
RW26-RW27	SOIL NAIL RETAINING WALL 'I' DETAILS

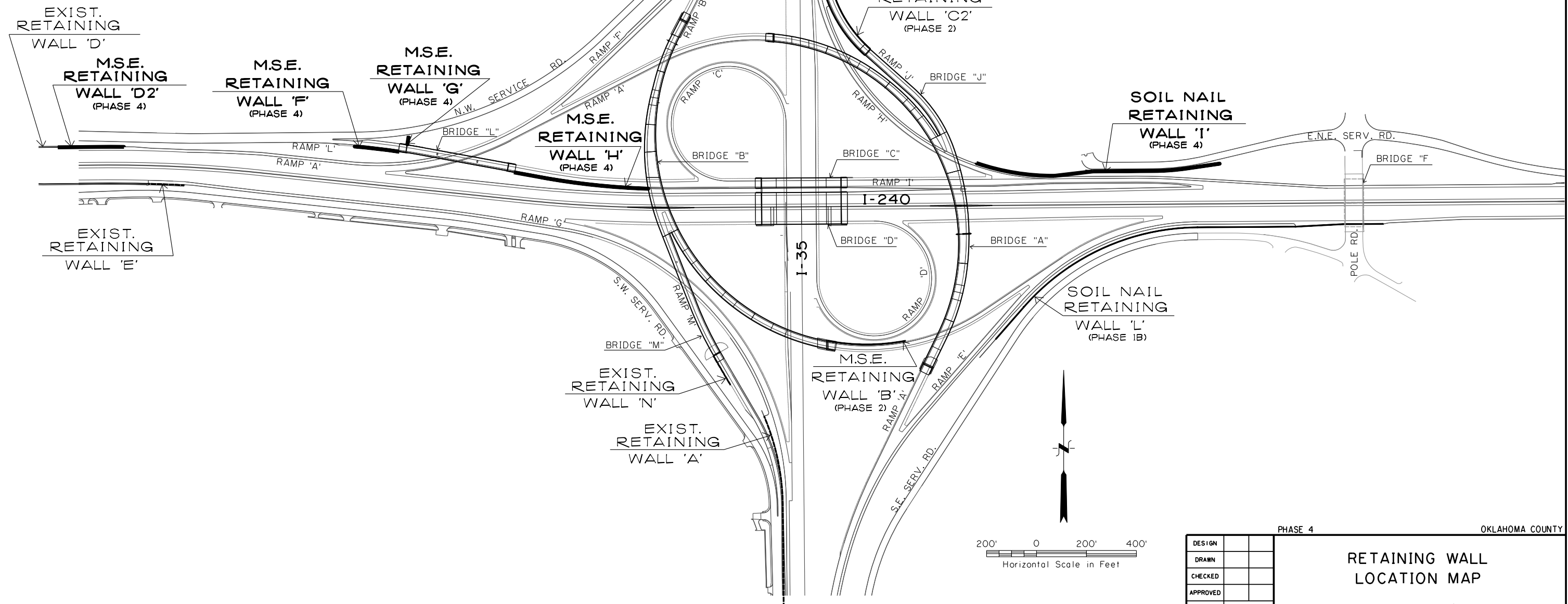

3/11/2024 5:06:32 PM H:\PROJECTS\2789_CrossRoads_Phase 4\Bridges\Drawings\Ph4 Walls\0903208 P4 LocationMap_Retaining_Walls.dgn

DESIGN	
DRAWN	
CHECKED	
APPROVED	
SQUAD	POE

PHASE 4 OKLAHOMA COUNTY

RETAINING WALL LOCATION MAP

STATE JOB NO. 09032(08) SHEET NO. RW01

SHEETING AND SHORING:
SHEETING AND SHORING SHALL BE THE RESPONSIBILITY OF THE CONTRACTOR AND SHALL BE DESIGNED BY A REGISTERED PROFESSIONAL ENGINEER IN THE STATE OF OKLAHOMA. DESIGN CALCULATIONS AND DRAWINGS SHALL BE SUBMITTED TO ODOT BRIDGE DIVISION FOR APPROVAL. PRIOR TO CONSTRUCTION. THE LIMITS OF THE SHEETING AND SHORING ARE TO BE DETERMINED BY THE CONTRACTOR. SEE SECTION 502.04.D OF THE 2009 STANDARD SPECIFICATIONS. ALL COST OF SHEETING AND SHORING TO BE INCLUDED IN COST OF "TEMPORARY EARTH RETAINAGE" ITEM.

CURVE DATA RWD2-1
 P.I. STA. 400+52.65
 N: 143139.6555
 E: 2148059.8267
 $\Delta = 1^{\circ}02'18.96''$ RT.
 $D = 0^{\circ}59'15.02''$
 T = 52.59'
 L = 105.17'
 R = 5802.08'
 E = 0.24'

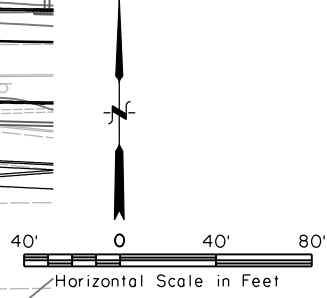
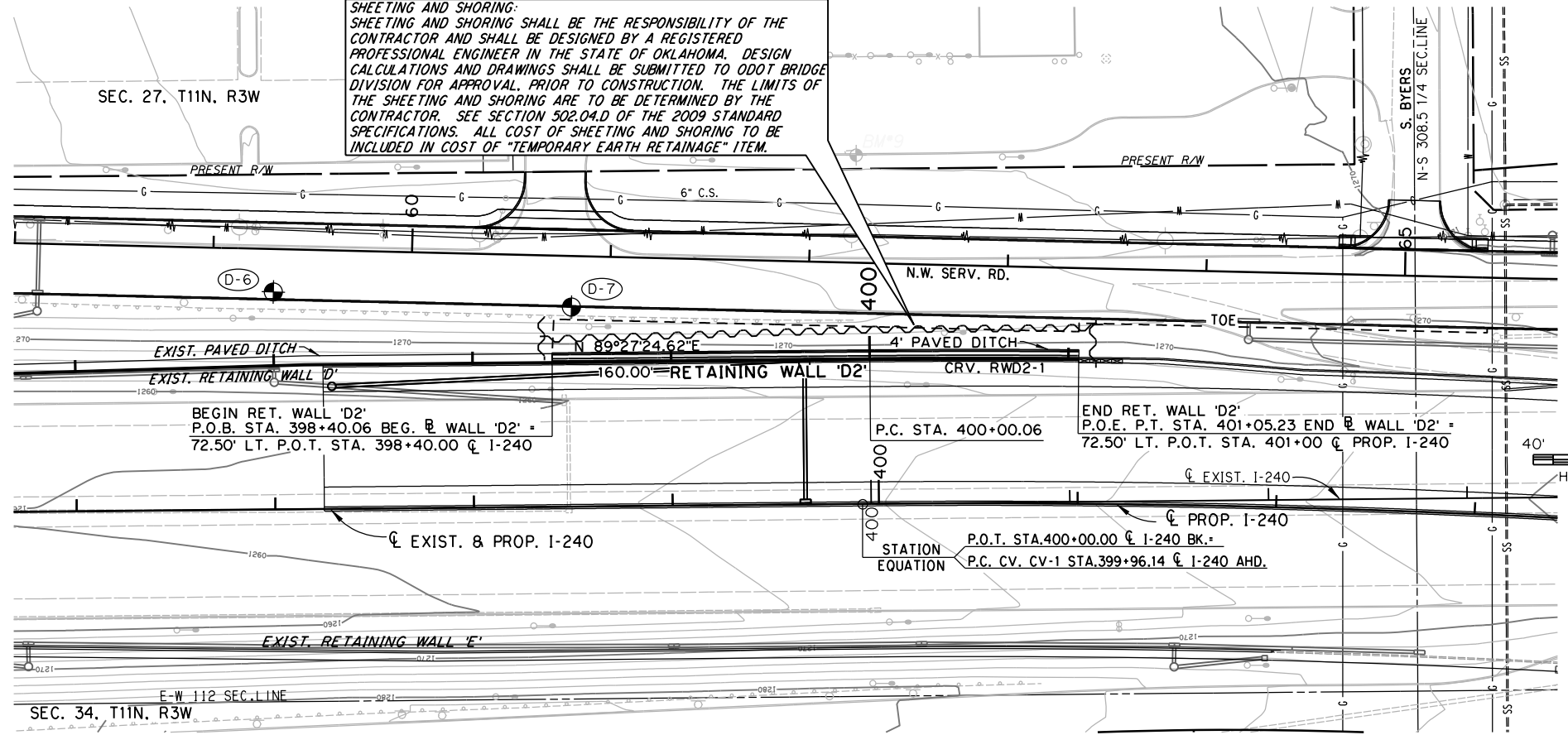

BM*10 - *X* ON CURB @ INLET S. PARKING LOT OF HOME DEPOT
175.60' LT. STA. 399+94.10 @ I-240
EL=1270.89

BM*11 - *X* ON CURB @ P.I.S. COR. PARKING LOT OF VALERO GAS STA.
176.68' LT. STA. 394+01.73 @ I-240
EL=1275.41

NOTE:
TR4 RAIL NOT SHOWN FOR CLARITY.

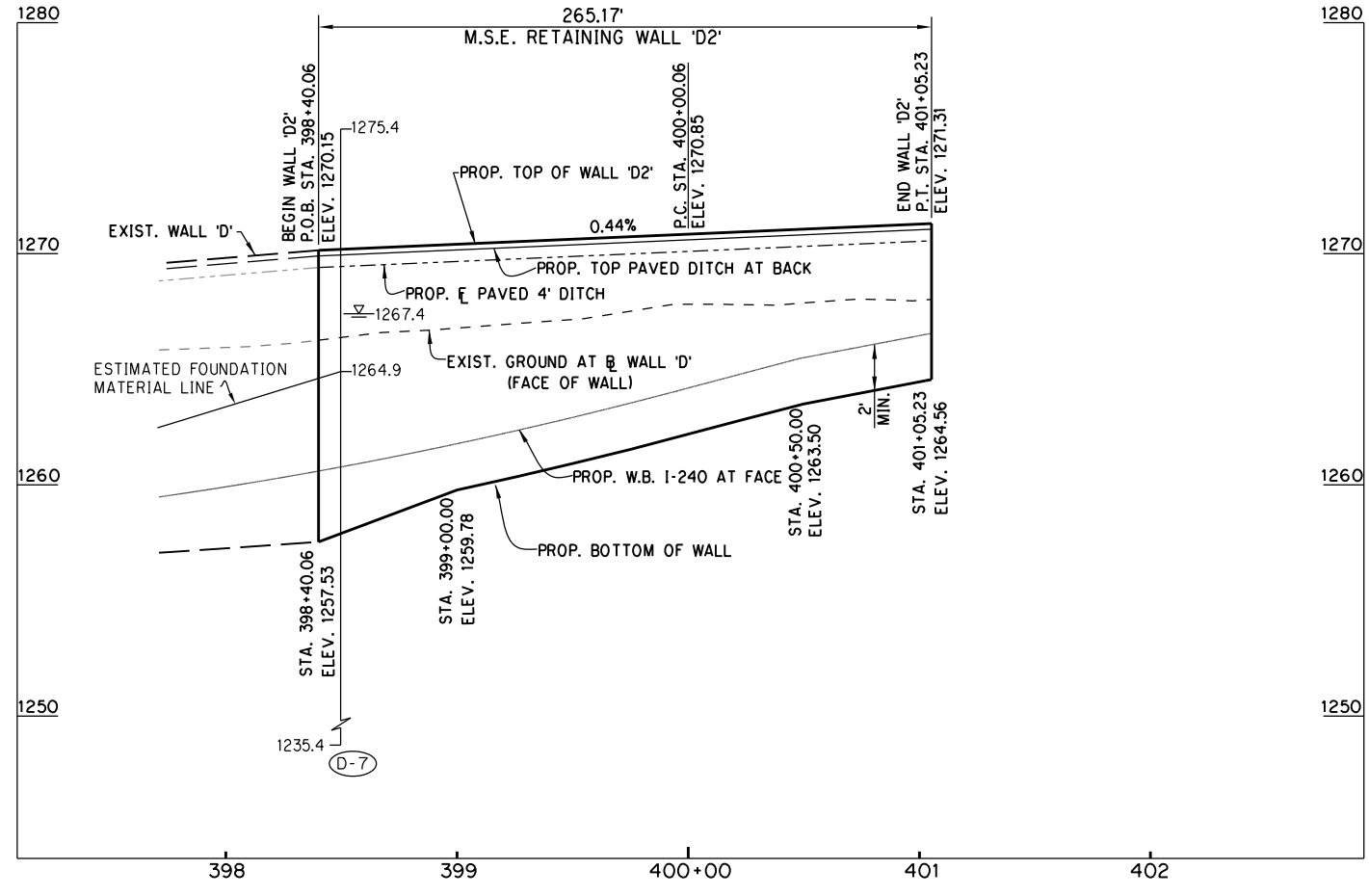

DESIGN			
DRAWN			
CHECKED			
APPROVED			
SQUAD	POE		

PHASE 4

OKLAHOMA COUNTY

M.S.E. RETAINING WALL 'D2'
PLAN & ELEVATION

STATE JOB NO. 09032(08) SHEET NO. RW02

2/22/2024 5:44:56 PM
 H:\PROJECTS\2789_CrossRoads_Phase 4\Bridges\Drawings\Ph4 Walls\0903208 P4 Wall D2 PE.dgn

Boring Number D-7
Station: 398+50
Offset: 100.5 Ft. Lt. CL I-240

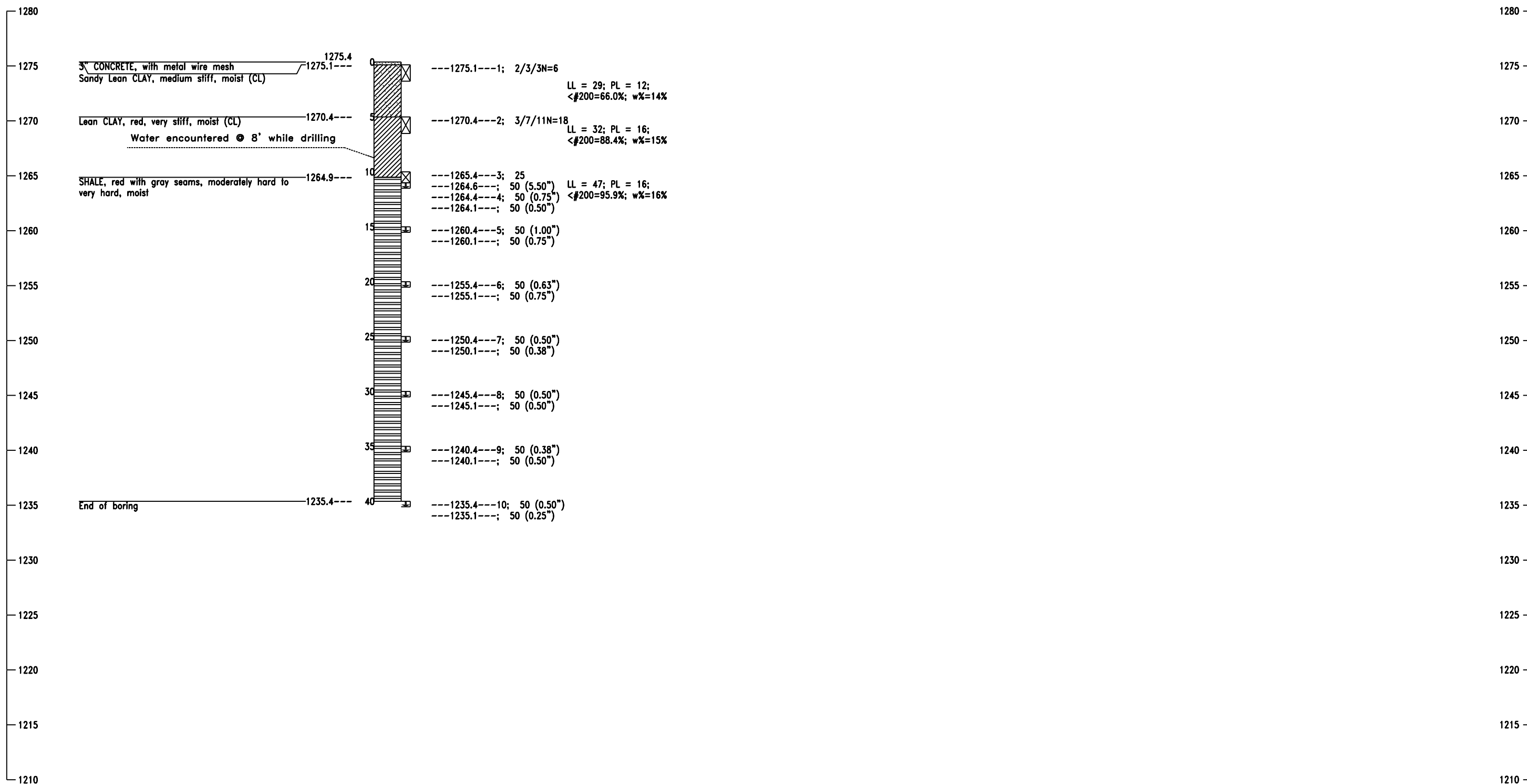

GEOLOGIC STATEMENT

"Division Four" of the "Engineering Classification of Geological Materials", published by the Oklahoma Department of Transportation (ODOT) indicates that the site is underlain by the Hennessey Unit (Phy). The geologic unit is described below.
This unit consists of red platy to blocky clay shales and mudstone. The mudstones are hard and appear blocky. The red clay shale of the Hennessey Unit is characterized by numerous bands of streaks of white or light green color ranging from a few inches to four feet in thickness.
The total thickness of the unit is about 400 feet.
The Hennessey Unit outcrops in a 5- to 15-mile north-south band across Grant, Garfield, Kingfisher, Logan, Canadian, and Oklahoma Counties in Division Four. Topographically, the unit is near level to gently rolling and is generally grass covered or cultivated.

GEOTECHNICAL REPORT

All geotechnical information contained on this sheet is covered by the engineering seal affixed to an original geotechnical engineering report that has been stamped and sealed by a professional engineer licensed in Oklahoma. To obtain a copy of the complete report, contact the ODOT office engineer at (405) 521-2625. The contractor should be fully aware of the site conditions prior to beginning work. Any additional geotechnical information which may be desired is the responsibility of the contractor.

Note: Water level elevations shown were obtained at the time the borings were drilled and may fluctuate throughout the year.

NOTE: SPT - Split Spoon Sampling <#200 - Percent passing #200 sieve
TCP - Texas Cone Penetrator Test w% - Moisture content
AUG - Augur Cutting Sample N - Number of blows per 12 inches
LL - Liquid Limit * Denotes depth to observed groundwater
PL - Plastic Limit

OKLAHOMA COUNTY

DESIGN	
DRAWN	
CHECKED	
APPROVED	
SQUAD	PSI

FOUNDATION REPORT
RETAINING WALL "D2"

STATE JOB NO. 09032(08) SHEET NO. RW03

CURVE DATA RWF-1
 P.I. STA. 411+08.41
 N: 143133.2214
 E: 2149124.1922
 Δ: 3°32'36.24" RT.
 D: 2°00'16.79"
 T: 88.41'
 L: 176.76'
 R: 2858.12'
 E: 1.37'

CURVE DATA RWF-2
 P.I. STA. 412+11.72
 N: 143118.0193
 E: 2149226.4405
 Δ: 0°36'00.00" RT.
 D: 2°00'16.79"
 T: 14.97'
 L: 29.93'
 R: 2858.12'
 E: 0.04'

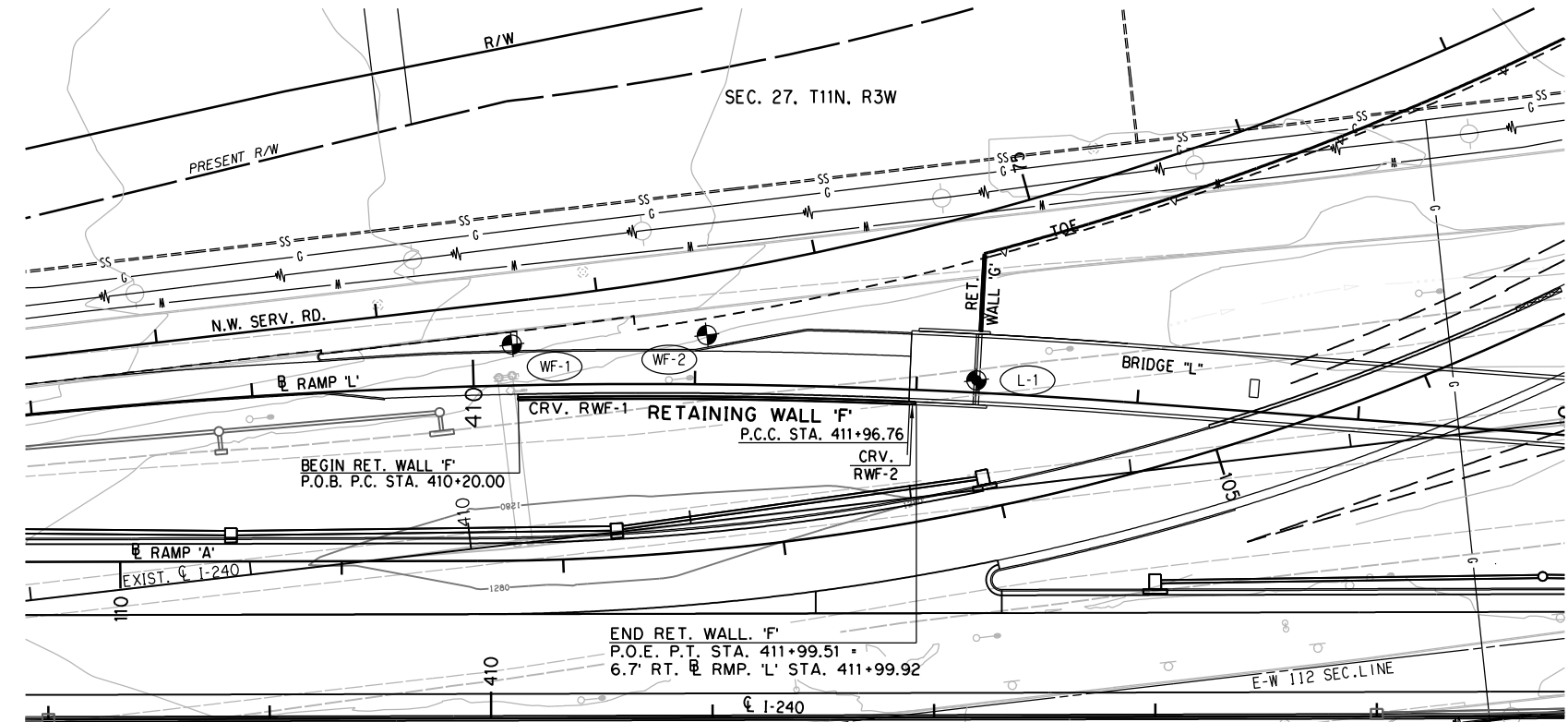

BM 8 ~ *X* ON CURB @ 521
 S.E. 72ND STREET
 STA. 406+48.06 @ I-240, 317.43' LT.
 ELEV. = 1267.15

BM 22 ~ *X* ON HEADWALL DRAINAGE
 STRUCTURE
 STA. 408+36.59 @ I-240, 271.68' RT.
 ELEV. = 1275.45

BM 23 ~ *X* ON CURB OF SIDEWALK
 ON NORTH SIDE BUILDING
 STA. 413+98.14 @ I-240, 319.36' RT.
 ELEV. = 1281.84

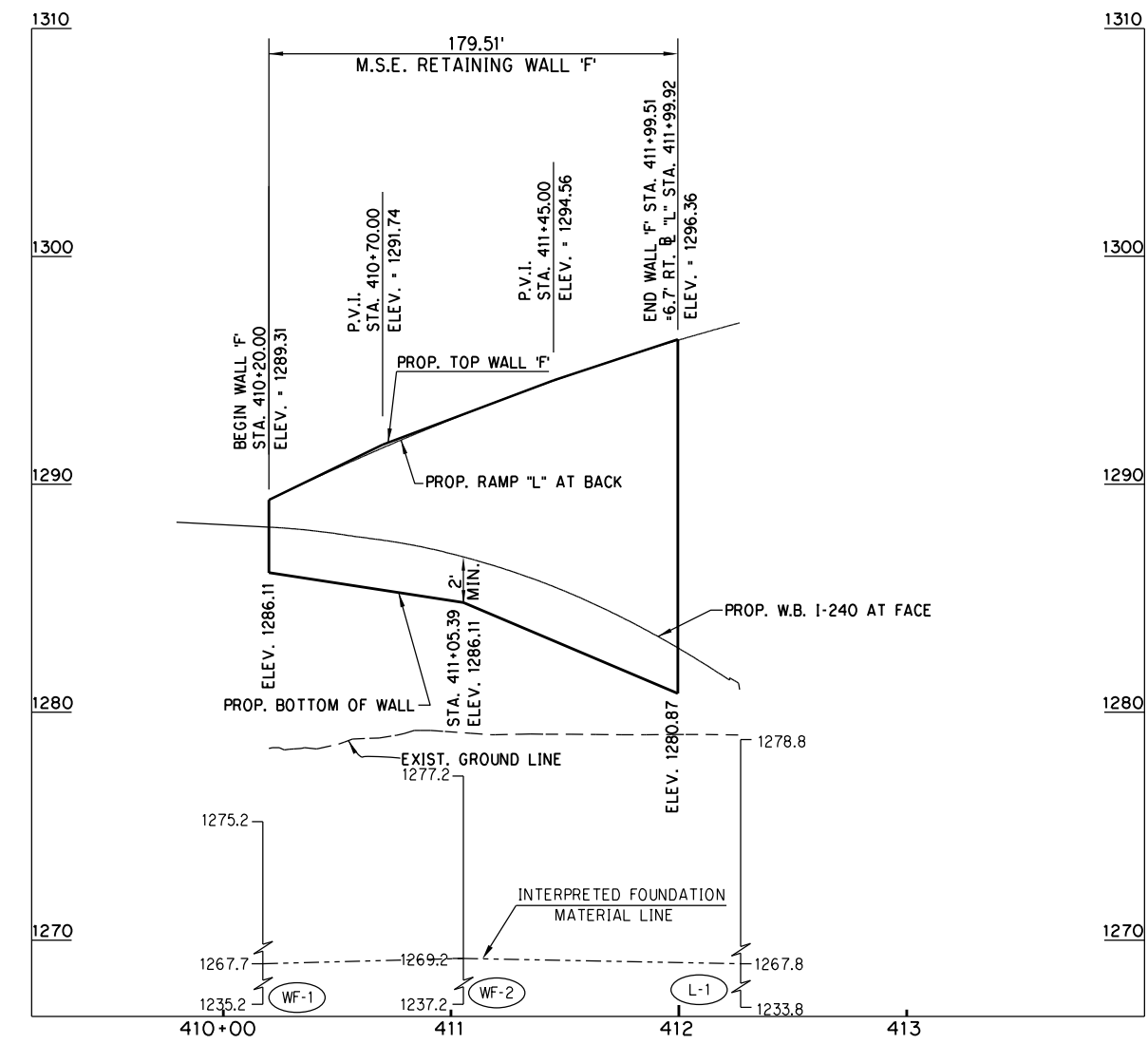

2/22/2024 5:45:00 PM H:\PROJECTS\2789_CrossRoads\Phase 4\Bridges\Drawings\Ph4 Walls\0903208 P4 Wall F PE.dgn

DESIGN	
DRAWN	
CHECKED	
APPROVED	
SQUAD	POE

PHASE 4
 OKLAHOMA COUNTY
M.S.E. RETAINING WALL 'F'
PLAN & ELEVATION
 STATE JOB NO. 09032(08) SHEET NO. RW04

Boring Number WF-1
Northing: 143166
Easting: 2149036
Date Drilled: 04/19/19

Boring Number WF-2
Northing: 143166
Easting: 2149036
Date Drilled: 04/09/19

Boring Number L-1
Northing: 143127.77
Easting: 2149242.89
Date Drilled: 01/30/19

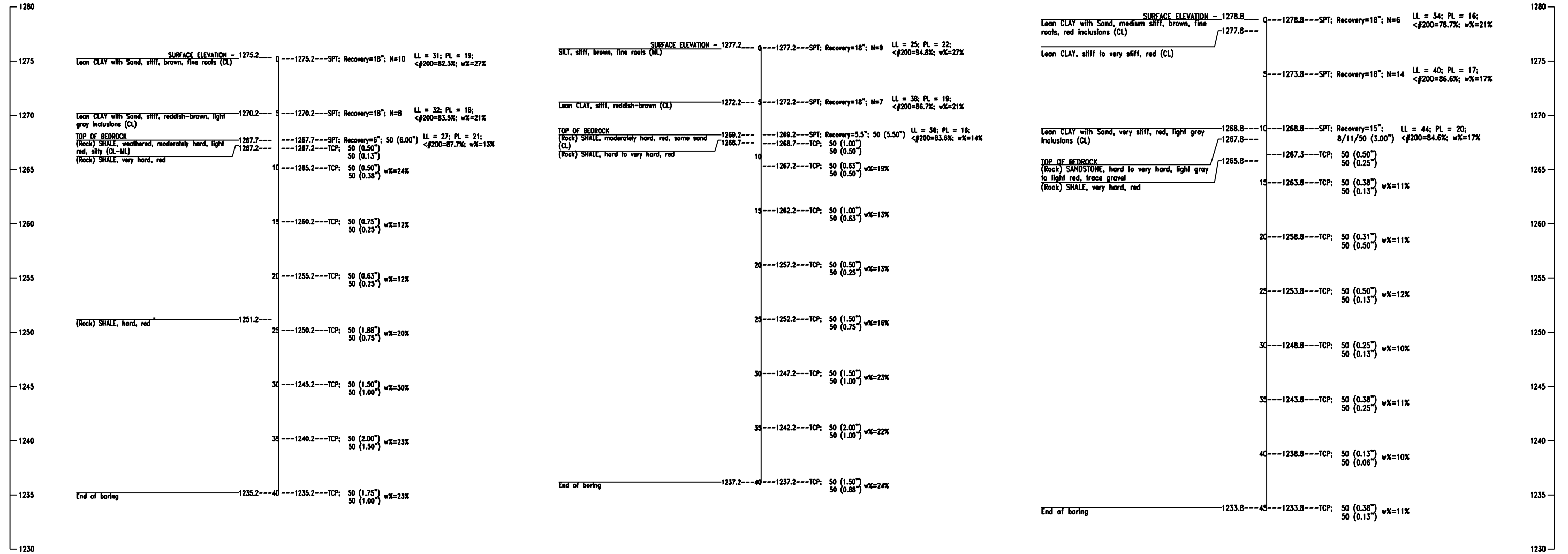

GEOLOGIC STATEMENT

"Division Four" of the "Engineering Classification of Geological Materials", published by the Oklahoma Department of Transportation (ODOT) indicates that the site is underlain by the Hennessey Unit (Phy). The geologic unit is described below. This unit consists of red platy to blocky clay shales and mudstone. The mudstones are hard and appear blocky. The red clay shale of the Hennessey Unit is characterized by numerous bands of streaks of white or light green color ranging from a few inches to four feet in thickness. The total thickness of the unit is about 400 feet. The Hennessey Unit outcrops in a 5- to 15-mile north-south band across Grant, Garfield, Kingfisher, Logan, Canadian, and Oklahoma Counties in Division Four. Topographically, the unit is near level to gently rolling and is generally grass covered or cultivated.

GEOTECHNICAL REPORT

All geotechnical information contained on this sheet is covered by the engineering seal affixed to an original geotechnical engineering report that has been stamped and sealed by a professional engineer licensed in Oklahoma. To obtain a copy of the complete report, contact the ODOT office engineer at (405) 521-2625. The contractor should be fully aware of the site conditions prior to beginning work. Any additional geotechnical information which may be desired is the responsibility of the contractor.

Note: Water level elevations shown were obtained at the time the borings were drilled and may fluctuate throughout the year.

NOTE: SPT - Split Spoon Sampling <#200 - Percent passing #200 sieve
TCP - Texas Cone Penetrator Test w% - Moisture content
AUG - Augur Cutting Sample N - Number of blows per 12 inches
LL - Liquid Limit * Denotes depth to observed groundwater
PL - Plastic Limit

PHASE 4

OKLAHOMA COUNTY

DESIGN	
DRAWN	
CHECKED	
APPROVED	
SQUAD	PSI

FOUNDATION REPORT
RETAINING WALL "F"

STATE JOB NO. 09032(08) SHEET NO. RW05

BM 8 ~ "X" ON CURB @ 52'
S.E. 72ND STREET
STA. 406+48.06 @ I-240, 317.43' LT.
ELEV.: 1267.15

BM 22 ~ "X" ON HEADWALL DRAINAGE
STRUCTURE
STA. 408+36.59 @ I-240, 271.68' RT.
ELEV.: 1275.45

BM 23 ~ "X" ON CURB OF SIDEWALK
ON NORTH SIDE BUILDING
STA. 413+98.14 @ I-240, 319.36' RT.
ELEV.: 1281.84

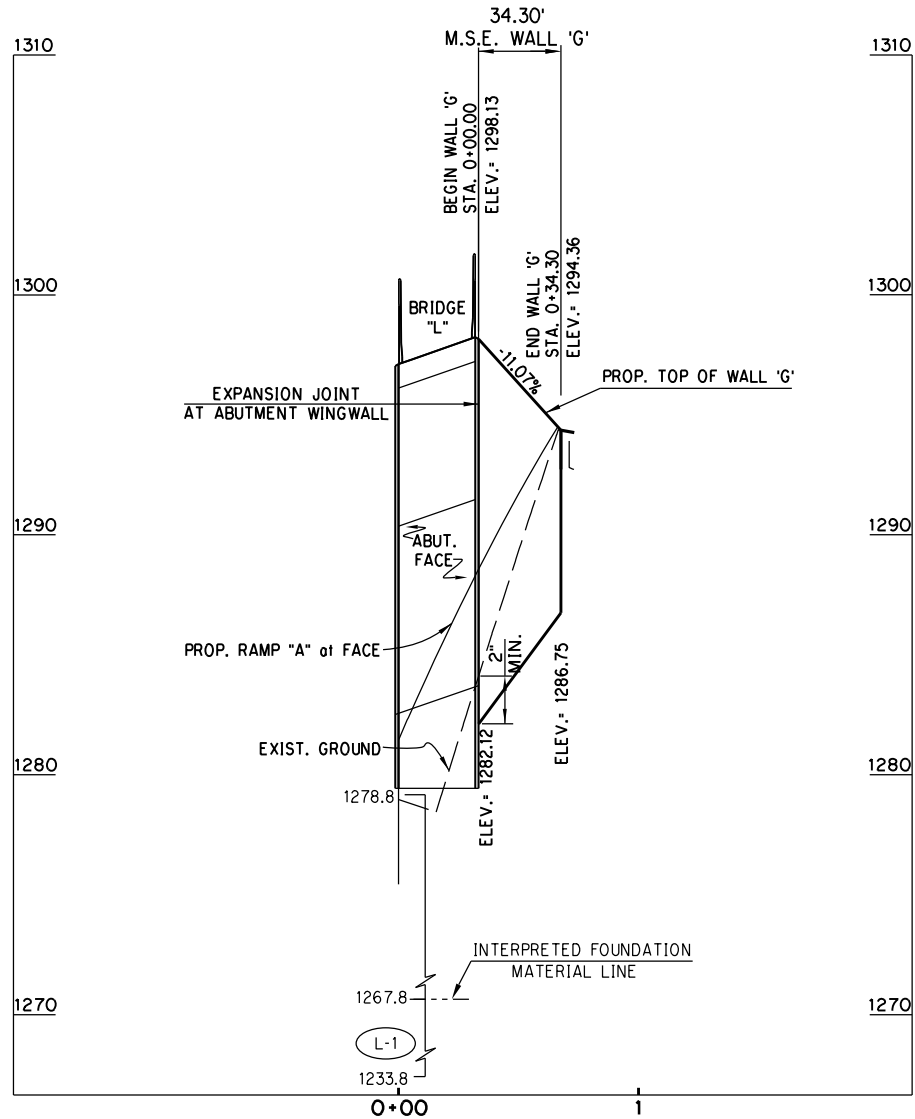
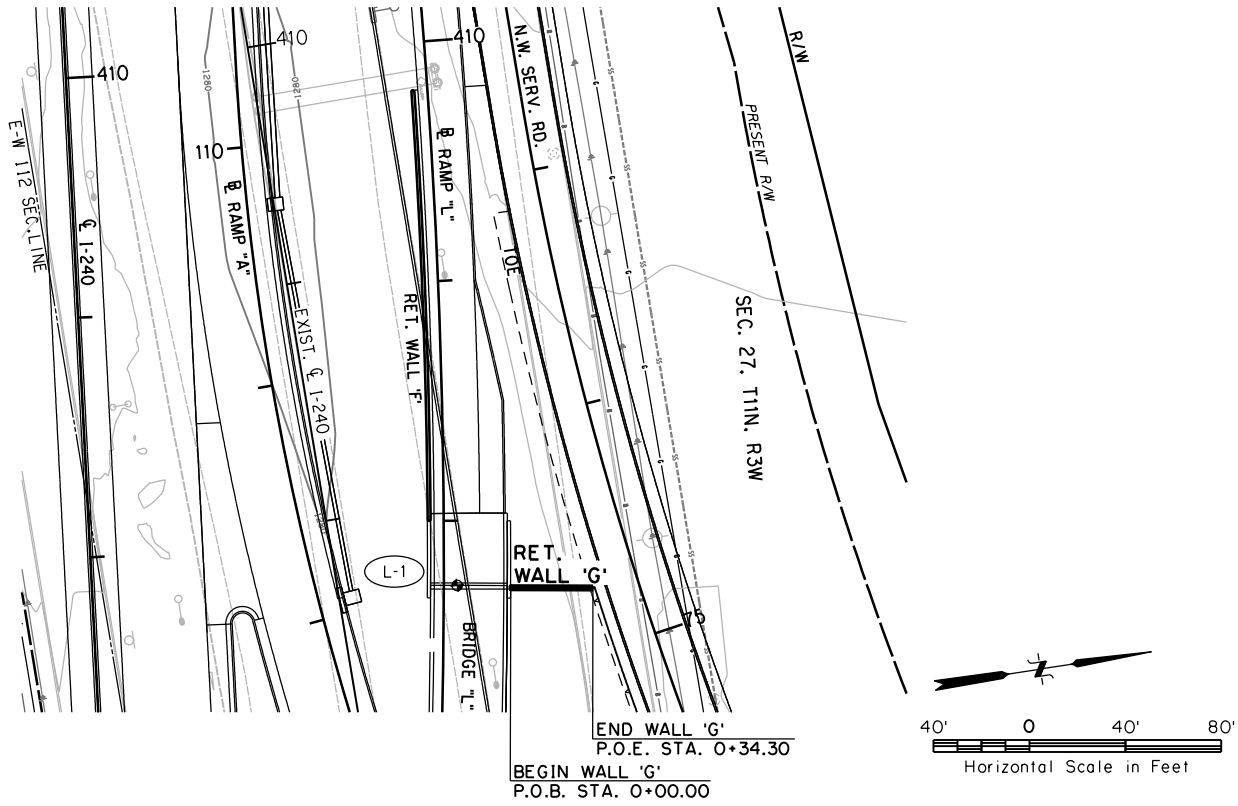

2/22/2024 5:45:03 PM H:\PROJECTS\2789_CrossRoads_Phase 4\Bridges\Drawings\Ph4 Walls\0903208 P4 Wall G PE.dgn

DESIGN	
DRAWN	
CHECKED	
APPROVED	
SQUAD	PSI

PHASE 4 OKLAHOMA COUNTY

M.S.E. RETAINING WALL 'G'
PLAN & ELEVATION

STATE JOB NO. 09032(08) SHEET NO. RW06

Boring Number L-1
Northing: 143127.77
Easting: 2149242.89
Date Drilled: 01/30/19

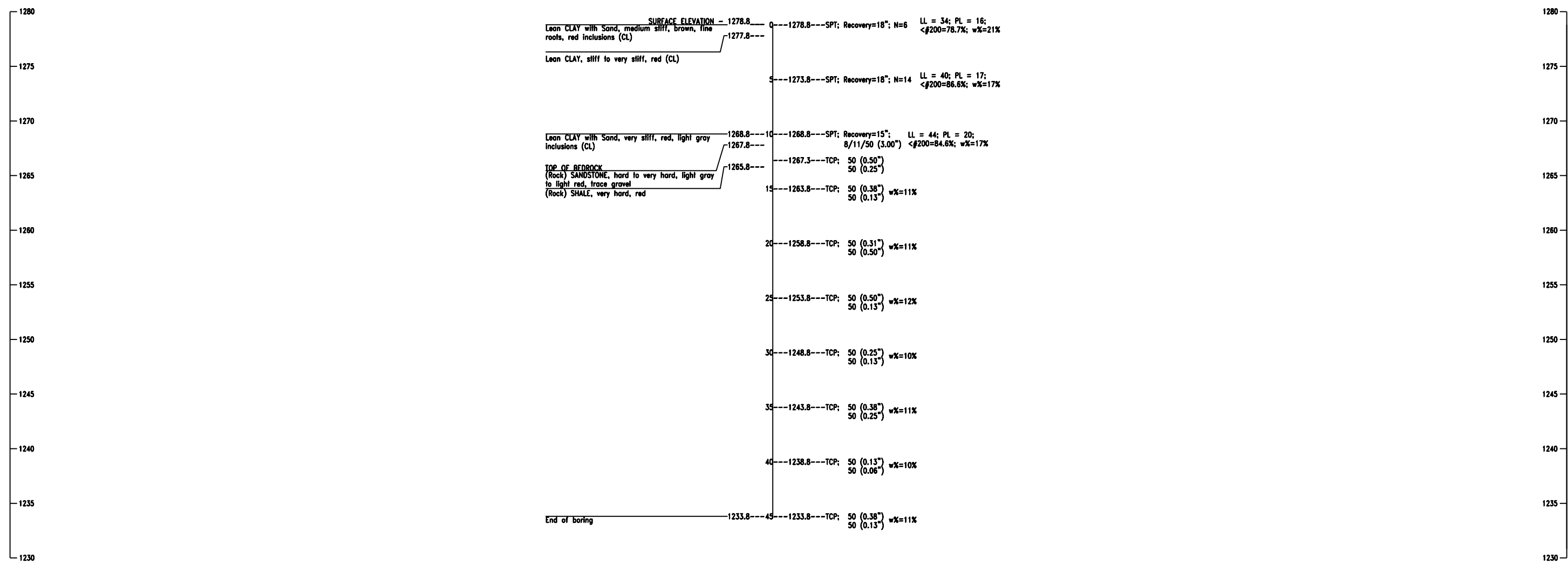

GEOLOGIC STATEMENT

"Division Four" of the "Engineering Classification of Geological Materials", published by the Oklahoma Department of Transportation (ODOT) indicates that the site is underlain by the Hennessey Unit (Phy). The geologic unit is described below. This unit consists of red platy to blocky clay shales and mudstone. The mudstones are hard and appear blocky. The red clay shale of the Hennessey Unit is characterized by numerous bands of streaks of white or light green color ranging from a few inches to four feet in thickness. The total thickness of the unit is about 400 feet. The Hennessey Unit outcrops in a 5- to 15-mile north-south band across Grant, Garfield, Kingfisher, Logan, Canadian, and Oklahoma Counties in Division Four. Topographically, the unit is near level to gently rolling and is generally grass covered or cultivated.

GEOTECHNICAL REPORT

All geotechnical information contained on this sheet is covered by the engineering seal affixed to an original geotechnical engineering report that has been stamped and sealed by a professional engineer licensed in Oklahoma. To obtain a copy of the complete report, contact the ODOT office engineer at (405) 521-2625. The contractor should be fully aware of the site conditions prior to beginning work. Any additional geotechnical information which may be desired is the responsibility of the contractor.

Note: Water level elevations shown were obtained at the time the borings were drilled and may fluctuate throughout the year.

NOTE: SPT - Split Spoon Sampling <#200 - Percent passing #200 sieve
TCP - Texas Cone Penetrator Test w% - Moisture content
AUG - Augur Cutting Sample N - Number of blows per 12 inches
LL - Liquid Limit PL - Plastic Limit * Denotes depth to observed groundwater

PHASE 4

OKLAHOMA COUNTY

DESIGN	
DRAWN	
CHECKED	
APPROVED	
SQUAD	PSI

FOUNDATION REPORT
RETAINING WALL "G"

STATE JOB NO. 09032(08) SHEET NO. RW07

CURVE DATA RWH-1

P.I. STA. 419+93.39
N: 142978.3114
E: 2149994.8649
Δ: 8°37'22.15" LT.
D: 1°59'05.95"
T= 217.61'
L= 434.40'
R= 2886.46'
E= 8.19'

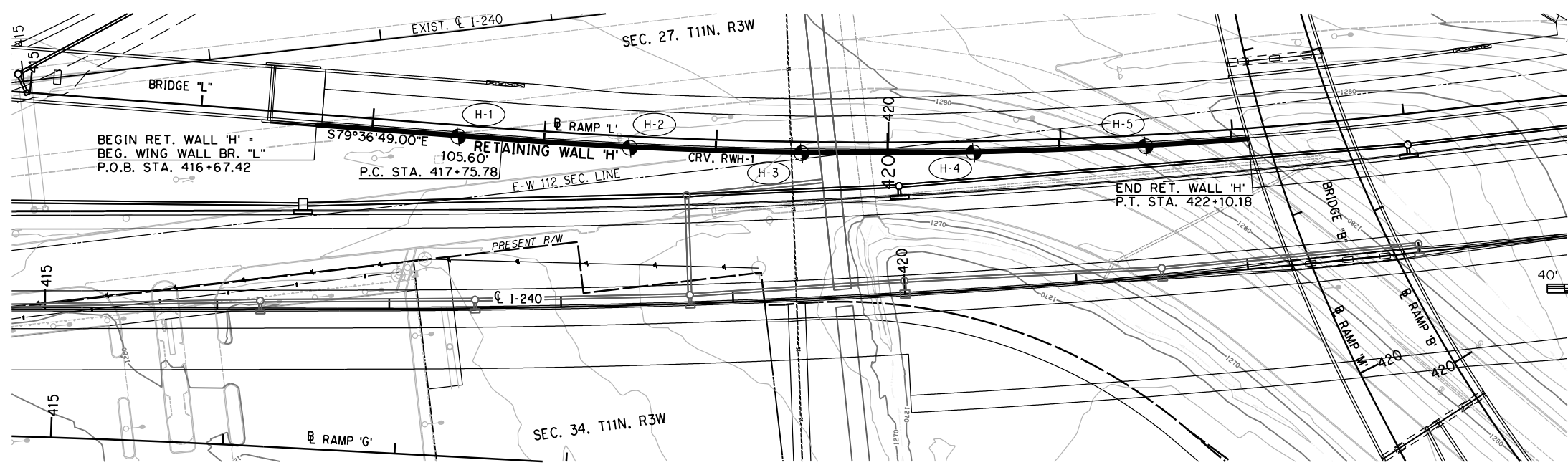
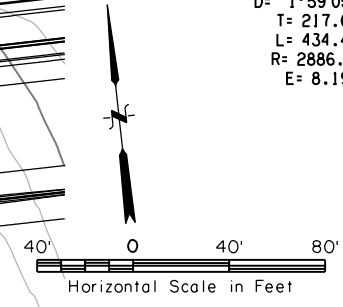

BM 25 ~ *6 REBAR EAST OF CREEK BEND
STA. 421+26.09 @ I-240, 620.62' RT.
ELEV.: 1278.24

BM 26 ~ *6 X 30" LG. REBAR
STA. 423+82.37 @ I-240, 774.34' RT.
ELEV.: 1283.54

BM 38 ~ *6 REBAR 6' WEST OF OG&E FENCE, 3RD LIGHT POLE FROM NORTH
STA. 437+77.03 @ I-240, 693.64' RT.
ELEV.: 1296.05

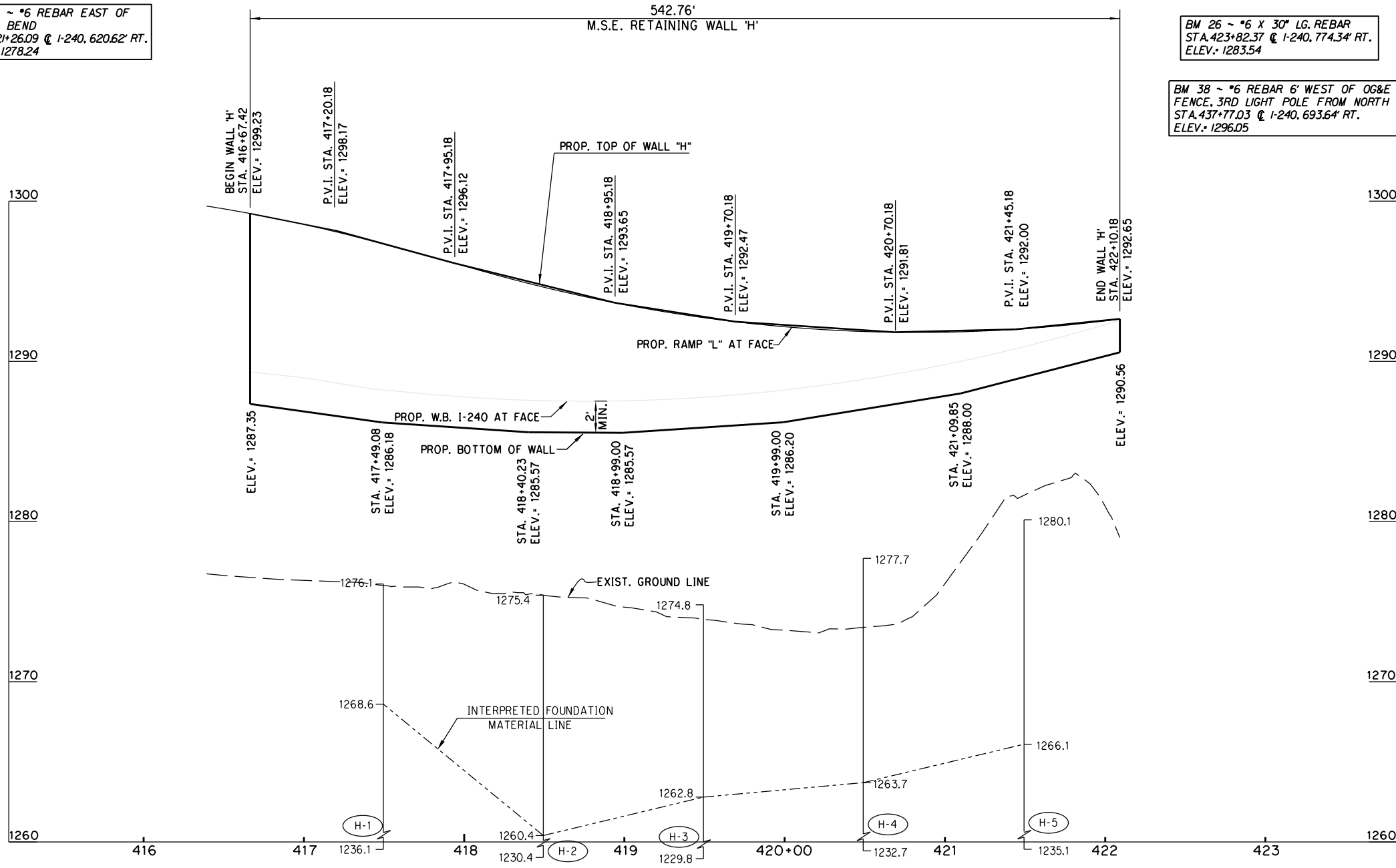

2/22/2024 5:45:06 PM H:\PROJECTS\2789_CrossRoads_Phase 4\Bridges\Drawings\Ph4 Walls\0903208 P4 Wall H PE.dgn

DESIGN	
DRAWN	
CHECKED	
APPROVED	
SQUAD	POE

PHASE 4 OKLAHOMA COUNTY
M.S.E. RETAINING WALL 'H'
PLAN & ELEVATION
STATE JOB NO. 09032(08) SHEET NO. RW08

Boring Number H-1
Northing: 143022.17
Easting: 2149755.53
Date Drilled: 01/31/19

Boring Number H-2
Northing: 143005.08
Easting: 2149854.04
Date Drilled: 01/31/19

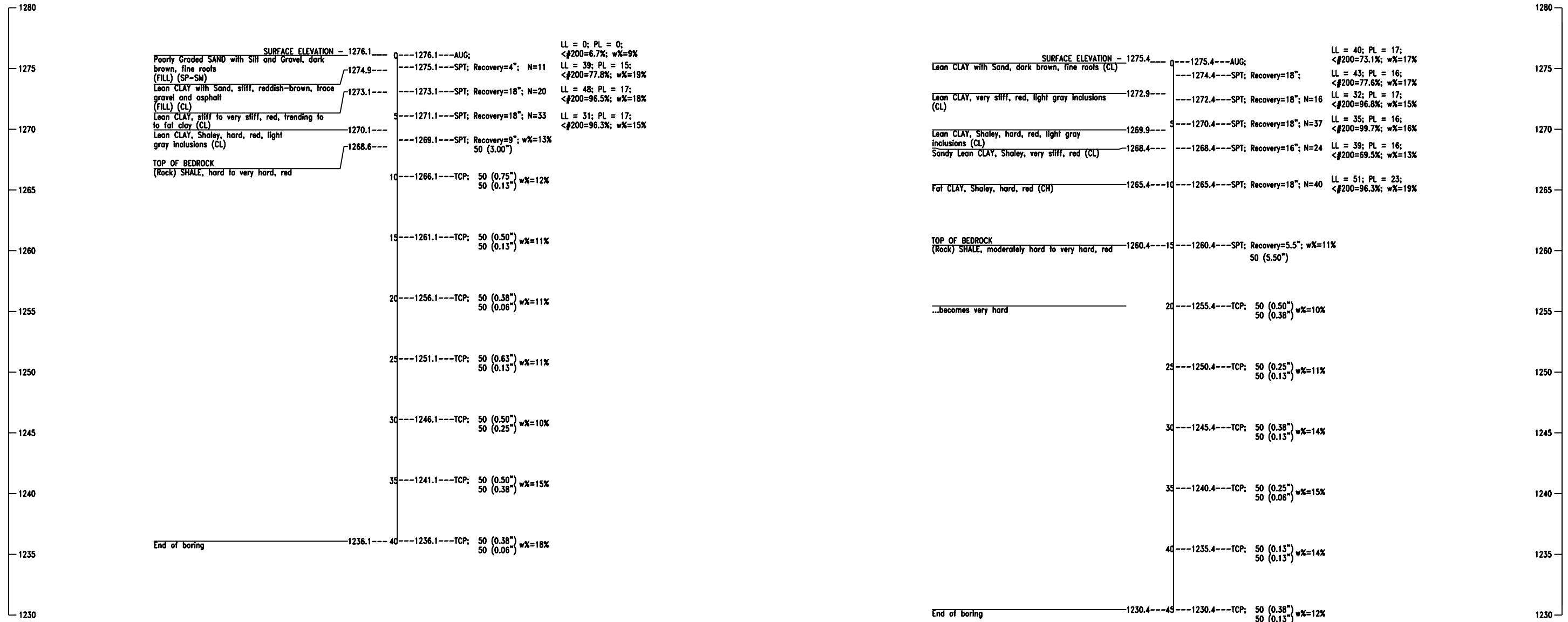

GEOLOGIC STATEMENT

"Division Four" of the "Engineering Classification of Geological Materials", published by the Oklahoma Department of Transportation (ODOT) indicates that the site is underlain by the Hennessey Unit (Phy). The geologic unit is described below. This unit consists of red platy to blocky clay shales and mudstone. The mudstones are hard and appear blocky. The red clay shale of the Hennessey Unit is characterized by numerous bands of streaks of white or light green color ranging from a few inches to four feet in thickness. The total thickness of the unit is about 400 feet. The Hennessey Unit outcrops in a 5- to 15-mile north-south band across Grant, Garfield, Kingfisher, Logan, Canadian, and Oklahoma Counties in Division Four. Topographically, the unit is near level to gently rolling and is generally grass covered or cultivated.

GEOTECHNICAL REPORT

All geotechnical information contained on this sheet is covered by the engineering seal affixed to an original geotechnical engineering report that has been stamped and sealed by a professional engineer licensed in Oklahoma. To obtain a copy of the complete report, contact the ODOT office engineer at (405) 521-2625. The contractor should be fully aware of the site conditions prior to beginning work. Any additional geotechnical information which may be desired is the responsibility of the contractor.

Note: Water level elevations shown were obtained at the time the borings were drilled and may fluctuate throughout the year.

NOTE: SPT - Split Spoon Sampling <#200 - Percent passing #200 sieve
TCP - Texas Cone Penetrometer Test w% - Moisture content
AUG - Augur Cutting Sample N - Number of blows per 12 inches
LL - Liquid Limit PL - Plastic Limit Denotes depth to observed groundwater

PHASE 4 OKLAHOMA COUNTY

DESIGN	
DRAWN	
CHECKED	
APPROVED	
SQUAD	PSI

FOUNDATION REPORT
RETAINING WALL "H"
(SHEET 1 OF 3)

STATE JOB NO. 09032(08) SHEET NO. RW09

Boring Number H-3
Northing: 142991.35
Easting: 2149953.01
Date Drilled: 01/31/19

Boring Number H-4
Northing: 142981.10
Easting: 2150052.50
Date Drilled: 02/01/19

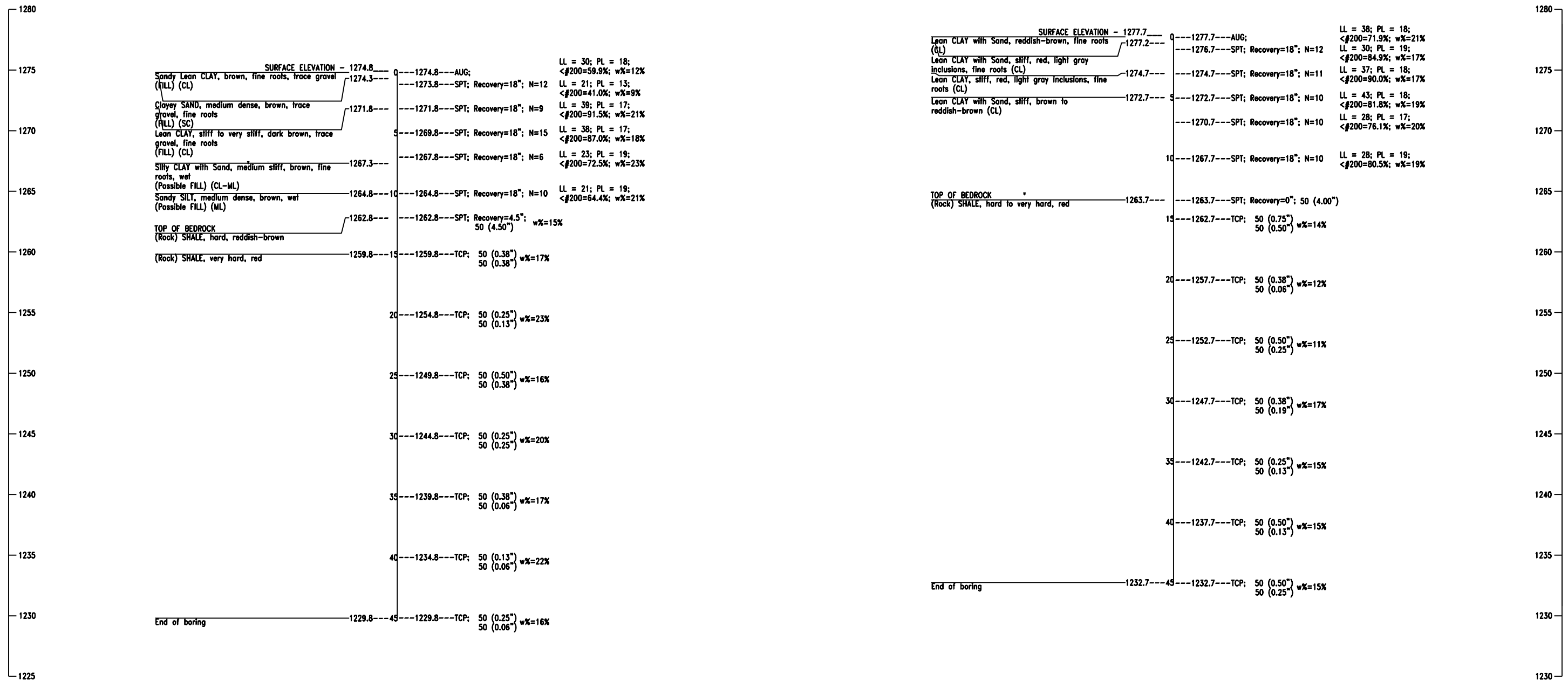

GEOLOGIC STATEMENT

"Division Four" of the "Engineering Classification of Geological Materials", published by the Oklahoma Department of Transportation (ODOT) indicates that the site is underlain by the Hennessey Unit (Phy). The geologic unit is described below.
This unit consists of red platy to blocky clay shales and mudstone. The mudstones are hard and appear blocky. The red clay shale of the Hennessey Unit is characterized by numerous bands of streaks of white or light green color ranging from a few inches to four feet in thickness.
The total thickness of the unit is about 400 feet.
The Hennessey Unit outcrops in a 5- to 15-mile north-south band across Grant, Garfield, Kingfisher, Logan, Canadian, and Oklahoma Counties in Division Four. Topographically, the unit is near level to gently rolling and is generally grass covered or cultivated.

GEOTECHNICAL REPORT

All geotechnical information contained on this sheet is covered by the engineering seal affixed to an original geotechnical engineering report that has been stamped and sealed by a professional engineer licensed in Oklahoma. To obtain a copy of the complete report, contact the ODOT office engineer at (405) 521-2625. The contractor should be fully aware of the site conditions prior to beginning work. Any additional geotechnical information which may be desired is the responsibility of the contractor.

Note: Water level elevations shown were obtained at the time the borings were drilled and may fluctuate throughout the year.

NOTE: SPT - Split Spoon Sampling <#200 - Percent passing #200 sieve
TCP - Texas Cone Penetrator Test w% - Moisture content
AUG - Augur Cutting Sample N - Number of blows per 12 inches
LL - Liquid Limit * Denotes depth to observed groundwater
PL - Plastic Limit

PHASE 4

OKLAHOMA COUNTY

DESIGN	
DRAWN	
CHECKED	
APPROVED	
SQUAD	PSI

FOUNDATION REPORT
RETAINING WALL "H"
(SHEET 2 OF 3)

STATE JOB NO. 09032(08) SHEET NO. RW10

Boring Number H-5
Northing: 142974.21
Easting: 2150152.29
Date Drilled: 02/01/19

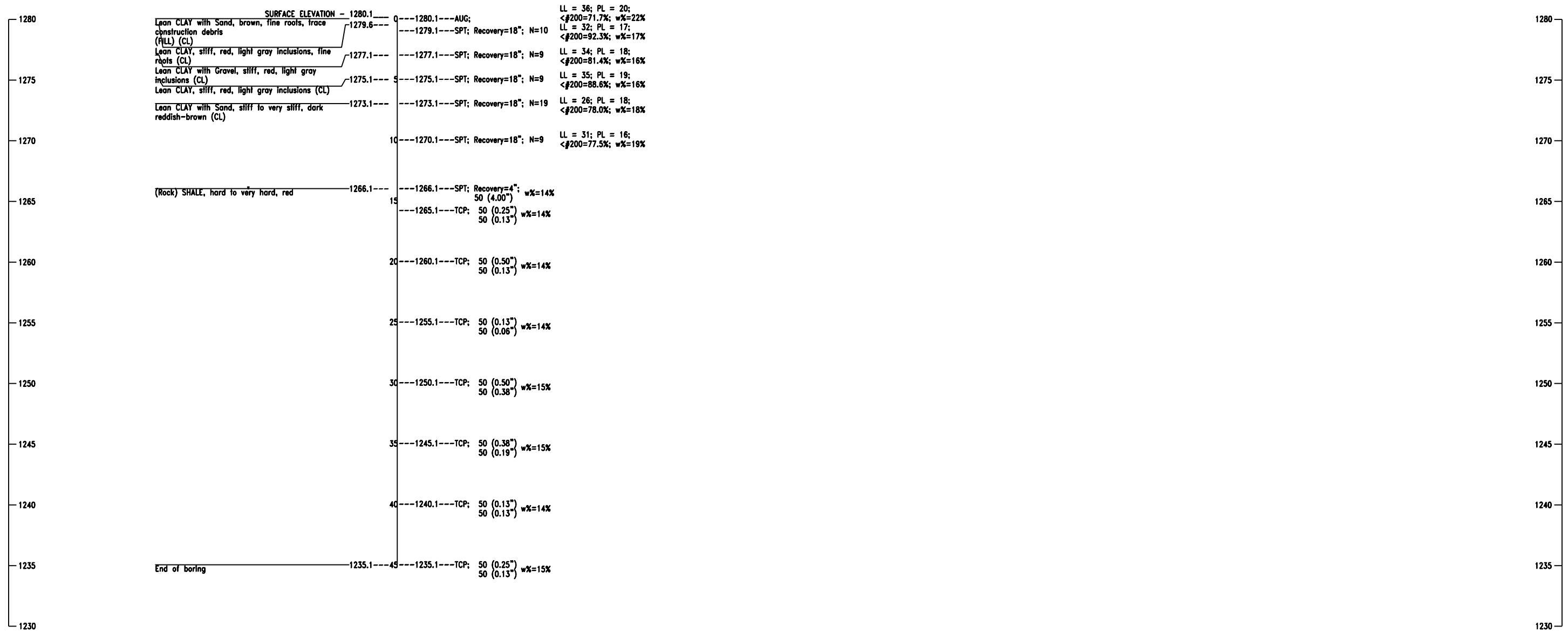

GEOLOGIC STATEMENT

"Division Four" of the "Engineering Classification of Geological Materials", published by the Oklahoma Department of Transportation (ODOT) indicates that the site is underlain by the Hennessey Unit (Phy). The geologic unit is described below.
This unit consists of red platy to blocky clay shales and mudstone. The mudstones are hard and appear blocky. The red clay shale of the Hennessey Unit is characterized by numerous bands of streaks of white or light green color ranging from a few inches to four feet in thickness.
The total thickness of the unit is about 400 feet.
The Hennessey Unit outcrops in a 5- to 15-mile north-south band across Grant, Garfield, Kingfisher, Logan, Canadian, and Oklahoma Counties in Division Four. Topographically, the unit is near level to gently rolling and is generally grass covered or cultivated.

GEOTECHNICAL REPORT

All geotechnical information contained on this sheet is covered by the engineering seal affixed to an original geotechnical engineering report that has been stamped and sealed by a professional engineer licensed in Oklahoma. To obtain a copy of the complete report, contact the ODOT office engineer at (405) 521-2625. The contractor should be fully aware of the site conditions prior to beginning work. Any additional geotechnical information which may be desired is the responsibility of the contractor.

Note: Water level elevations shown were obtained at the time the borings were drilled and may fluctuate throughout the year.

NOTE: SPT - Split Spoon Sampling <#200 - Percent passing #200 sieve
TCP - Texas Cone Penetrator Test w% - Moisture content
AUG - Augur Cutting Sample N - Number of blows per 12 inches
LL - Liquid Limit PL - Plastic Limit
Denotes depth to observed groundwater

PHASE 4 OKLAHOMA COUNTY

DESIGN	
DRAWN	
CHECKED	
APPROVED	
SQUAD	PSI

FOUNDATION REPORT
RETAINING WALL "H"
(SHEET 3 OF 3)

STATE JOB NO. 09032(08) SHEET NO. RW11

M.S.E. NOTES

TYPICAL FORM LINER AND CONCRETE FINISH NOTES:

THE EXPOSED CONCRETE SURFACES OF THE RETAINING WALL SYSTEM SHALL HAVE THE FORM LINER SURFACE TREATMENT THAT HAS BEEN PRE-APPROVED BY THE ENGINEER FOR THE AESTHETIC THEME OF THE PROJECT.

THE CONTRACTOR SHALL SUBMIT THE MANUFACTURER'S INSTALLATION INSTRUCTIONS AND PRODUCT DATA FOR THE TEXTURE SURFACE TREATMENTS. SHOP DRAWINGS SHALL INDICATE FORM LINER LAYOUT, RUSTICATION, REVEAL, AND CHAMFER STRIPS. LOCATION OF JOINTS AND FORM TIES SHALL BE INCLUDED. THE CONTRACTOR SHALL PROVIDE THE ENGINEER, FOR HIS APPROVAL, A SAMPLE PANEL OF THE APPROVED FORM LINER SURFACE TREATMENTS. THE SAMPLE PANEL SHALL BE AN 2' x 2' PANEL WITH SURFACE TREATMENTS, FOLLOWING THE APPROVAL OF THE SMALL SAMPLE PANEL.

THE CONTRACTOR SHALL PROVIDE ONE FULL SCALE MOCK-UP PANEL OF THE SURFACE TREATMENT USING PROPOSED MATERIALS, METHODS AND WORKMANSHIP. THE PANELS SHALL BE APPROVED BY THE ENGINEER ON THE SITE. THE MOCK-UP PANELS SHALL BE A MINIMUM OF 50 SQUARE FEET IN SIZE, AND MAY BE INCORPORATED INTO THE ACTUAL WALLS.

THE MOCK-UP PANEL SHALL INCORPORATE THE PROPOSED CONCRETE MIX, FORM WORK, TIES, FORM LINER, FORM RELEASE AGENTS, PLACEMENT RATE, FORM PRESSURES, JOINT SEALER, VIBRATING, AND FORM STRIPPING PRACTICES.

THE MOCK-UPS SHALL BE ACCEPTED BY THE ENGINEER PRIOR TO BEGINNING FORM WORK FOR THE PROJECT. THE ACCEPTED MOCK-UPS WILL BE THE STANDARD FOR TECHNICAL AND AESTHETIC MERIT.

FORM WORK SHALL BE DESIGNED BY THE CONTRACTOR TO COMPLY WITH ALL REQUIREMENTS BY THE FORM LINER MANUFACTURER. THIS INCLUDES, ALL REQUIREMENTS OF THE FORM LINER MANUFACTURER FOR HANDLING AND INSTALLATION OF THE FORM LINERS AS WELL AS THE APPLICATION OF RELEASE AGENTS, PLACEMENT OF CONCRETE, VIBRATING OF CONCRETE, AND REMOVAL OF FORMS SHALL BE FOLLOWED. FORM LINER BUTT JOINT SHALL BE CAREFULLY LINED UP TO PROVIDE A SURFACE FREE FROM VISIBLE SEAM LINES.

GENERAL NOTES FOR M.S.E. WALLS:

MATERIALS, DESIGN, AND METHODS USED IN CONSTRUCTION OF RETAINING WALLS SHALL BE IN ACCORDANCE WITH 2009 OKLAHOMA DEPARTMENT OF TRANSPORTATION STANDARD SPECIFICATIONS FOR HIGHWAY CONSTRUCTION, UNLESS OTHERWISE NOTED.

THE REINFORCED ZONE MATERIALS SHALL EXTEND HORIZONTALLY FROM THE BACK OF THE PANELS TO THE END OF THE EARTH REINFORCEMENTS. THE REINFORCED ZONE MATERIAL SHALL EXTEND VERTICALLY FROM THE TOP OF THE LEVELING PAD TO THE PROPOSED GROUND LINE.

MINIMUM EARTH OR PAVEMENT COVER OF 2.0' SHALL BE PROVIDED FROM THE TOP OF THE LEVELING PAD FINISHED GRADE.

STANDARD PRECAST CONCRETE PANELS SHALL HAVE A MAXIMUM PANEL HEIGHT OF SIX (6') FEET AND A MINIMUM PANEL HEIGHT OF FOUR (4') FEET.

AN OPEN JOINT SHALL BE PROVIDED AROUND THE PERIMETER OF THE CONCRETE PANELS. THE NOMINAL JOINT OPENING SHALL BE BETWEEN 3/8" AND 1/4". THE JOINT CONFIGURATION SHALL BE SUCH THAT THE FILTER FABRIC OR PAD MATERIALS ARE NOT EXPOSED AT THE WALL FACE.

PANELS SHALL FOLLOW THE CURVATURE OF THE WALL AS SHOWN IN THE PLANS. A ONE PIECE CORNER PANEL SHALL BE PROVIDED FOR WALL ANGLE CHANGES OF GREATER THAN 30 DEGREES. BUTTING OF CHAMFERED PANELS WILL BE ALLOWED FOR ANGLE CHANGES OF 30 DEGREES OR LESS.

A CONCRETE COPING SHALL BE PROVIDED ALONG THE TOP OF WALLS. THE JOINTS BETWEEN ALL COPING SEGMENTS SHALL BE SEALED TO PREVENT INFILTRATION OF WATER INTO THE RETAINING WALL BACKFILL. SEALING SHALL BE IN ACCORDANCE WITH SECTION 504 OF THE STANDARD SPECIFICATIONS. ALL COST FOR SEALING COPING SEGMENTS SHALL BE INCLUDED IN THE UNIT PRICE BID PER SQ. YARD OF "IPL" M.S.E. RETAINING WALLS". IF CAST-IN-PLACE COPING IS USED, THEN JOINTS SHALL BE PLACED TO COINCIDE WITH PRECAST PANEL JOINTS. THE WALL FACE PANELS SHALL EXTEND UP INTO THE COPING A MINIMUM OF 2 INCHES.

IF COPING IS PRECAST, A SMOOTH LEVEL-UP STRIP SHALL BE PROVIDED ON TOP OF THE PRECAST PANELS PRIOR TO INSTALLATION OF THE COPING. SHIMS MAY BE USED ON TOP OF THE LEVEL-UP STRIP TO FACILITATE ALIGNMENT.

IF EXISTING OR FUTURE STRUCTURES, PIPES, FOUNDATIONS OR GUARDRAIL POSTS WHICH ARE WITHIN REINFORCED SOIL VOLUME INTERFERE WITH THE NORMAL PLACEMENT OF REINFORCING MESH AND SPECIFIC DIRECTION HAS NOT BEEN PROVIDED ON THE PLANS. THE CONTRACTOR SHALL NOTIFY THE ENGINEER TO DETERMINE WHAT SOURCE OF ACTION SHOULD BE TAKEN.

DESIGN NOTES:

MECHANICALLY STABILIZED EARTH (M.S.E.) WALLS SHALL BE THE RESPONSIBILITY OF THE CONTRACTOR AND SHALL BE DESIGNED BY A REGISTERED PROFESSIONAL ENGINEER IN THE STATE OF OKLAHOMA IN ACCORDANCE WITH THE CURRENT EDITION OF THE AASHTO LRFD DESIGN SPECIFICATIONS AND CURRENT INTERIMS. DESIGN CALCULATIONS AND DRAWINGS SHALL BE SUBMITTED TO ODOT BRIDGE DIVISION FOR APPROVAL PRIOR TO CONSTRUCTION.

THERE SHALL BE NO SURCHARGE WITHIN 25 FEET OF THE CREST OF THE TEMPORARY EXCAVATION SLOPE DURING CONSTRUCTION OF THE RETAINING WALLS.

WHERE RECOMMENDED TEMPORARY EXCAVATION SLOPES WOULD RESULT IN RIGHT-OF-WAY ENCROACHMENT, OR FOR THE PURPOSES OF SOIL STABILITY DURING EXCAVATION, TEMPORARY SHEET PILING SHALL BE REQUIRED. AT THE CONTRACTOR'S OPTION AND WITH APPROVAL OF THE ENGINEER, THE TEMPORARY SHEET PILING MAY BE CUT A MINIMUM OF 2' BELOW THE GROUND LINE AND LEFT IN PLACE.

CARE SHALL BE TAKEN IN THE DESIGN AND DURING CONSTRUCTION TO DEVELOP AND MAINTAIN RAPID, POSITIVE DRAINAGE AWAY FROM THE RETAINING WALL AREA. WATER SHOULD NOT BE ALLOWED TO POND ADJACENT TO EITHER THE UP SLOPE OR DOWN SLOPE SIDES OF THE RETAINING WALL. PROPER SURFACE DRAINAGE IS NEEDED TO PREVENT WATER FROM FLOWING OVER THE FACE OF THE WALL AND SATURATING EITHER THE FILL BEHIND THE WALL OR THE SUBGRADE SOILS AT THE BASE OF THE WALL.

CONVENTIONAL DE-WATERING METHODS SHOULD BE ADEQUATE FOR TEMPORARY REMOVAL OF ANY GROUNDWATER ENCOUNTERED DURING THE SHALLOW EXCAVATION PROCESS. MORE EXTENSIVE DE-WATERING MAY BE REQUIRED FOR EXCAVATIONS TO REMOVE SOFT SOILS AND/OR IF CONSTRUCTION OCCURS DURING WET PERIODS OF THE YEAR.

DESIGN PARAMETERS FOR M.S.E. RETAINING WALLS:

DESIGN OF THE M.S.E. RETAINING WALLS BACKFILL SHALL BE BASED ON THE FOLLOWING DESIGN PARAMETERS:

MINIMUM UNIT WEIGHT = 120 PCF
MAXIMUM FRICTION ANGLE = 34°
COHESION = 0 PSF

FOR ANALYSIS OF ULTIMATE AND ALLOWABLE BEARING CAPACITY, IF THE WATER IS LOCATED AT OR ABOVE THE LEVELING PAD, A BUOYANT UNIT WEIGHT OF 65 POUNDS PER CUBIC FOOT SHALL BE USED. SEE GEOTECHNICAL REPORTS FOR GROUND WATER ELEVATIONS.

IN ALL AREAS, IT IS RECOMMENDED THE CONTRACTOR REVIEW THE GEOTECHNICAL REPORT AND STABILITY RESULTS IN THE REPORT THAT IS AVAILABLE FOR THE CONTRACTOR'S USE. GLOBAL STABILITY EVALUATION SHALL BE THE RESPONSIBILITY OF THE CONTRACTOR. GEOTECHNICAL TESTING WAS COMPLETED IN ACCORDANCE WITH THE LATEST EDITION OF THE STATE OF OKLAHOMA DEPARTMENT OF TRANSPORTATION SPECIFICATIONS FOR GEOTECHNICAL INVESTIGATION OF BRIDGES AND RELATED STRUCTURES.

PREPARATION OF THE FOUNDATION MATERIAL FOR THE M.S.E. WALLS, WHETHER IN-SITU MATERIAL OR NEW EMBANKMENT MATERIAL, SHALL BE COMPACTED TO NOT LESS THAN 95% OF THE STANDARD DENSITY.

WHERE NEW EMBANKMENT IS NECESSARY, IT SHALL BE PLACED AND COMPACTED IN 6" LIFTS OF LOOSE MATERIALS TO NOT LESS THAN 95% OF THE STANDARD PROCTOR DENSITY. ALL DENSITY TESTS SHALL BE TESTED IN ACCORDANCE TO SECTION 106.03 OF THE 2009 ODOT STANDARD SPECIFICATIONS FOR HIGHWAY CONSTRUCTION.

CONTRACTOR SHALL BE RESPONSIBLE FOR DESIGN OF THE M.S.E. WALLS FOR:

- INTERNAL STABILITY INCLUDING: TENSILE STRESSES, PULLOUT, FACING CONNECTION, SLIDING ALONG REINFORCEMENT, AND COMPOUND SLOPE STABILITY.
- LOCAL STABILITY INCLUDING: BULGING AND MAXIMUM UNREINFORCED HEIGHTS.
- DESIGN THE M.S.E. WALLS TO ACCOUNT FOR DEAD AND LIVE LOADS, SEISMIC LOADS, HORIZONTAL LOADS FROM GUARDRAILS OR BARRIERS, HYDROSTATIC LOADS, AND OTHER LOADS AS APPROPRIATE.
- DESIGN THE M.S.E. WALL SUCH THAT THE TOE IS AT A DEPTH THAT NO SCOURING OR UNDERMINING WILL OCCUR.
- DESIGN OF M.S.E. WALL STRAPS OR TIE-BACKS SHALL BE LOCATED BELOW THE PROPOSED F-SHAPED PARAPET AND MOMENT SLABS TO PREVENT CONFLICT. SEE M.S.E. WALL TYPICAL SECTIONS AND DETAILS.
- GLOBAL STABILITY EVALUATION.

FOR FURTHER DESIGN INFORMATION NOT PROVIDED IN THE PLANS OR GEOTECHNICAL REPORT, REFER TO THE 2009 OKLAHOMA DEPARTMENT OF TRANSPORTATION STANDARD SPECIFICATIONS FOR HIGHWAY CONSTRUCTION.

PAYMENT:

THE PAYMENT FOR M.S.E. RETAINING WALL SHALL BE BASED ON THE SURFACE AREA SHOWN ON THE PLAN AND PROFILE SHEETS FROM THE TOP OF THE RETAINING WALLS TO TOP OF LEVELING PAD NOT TO EXCEED 2 FEET BELOW FINISH GRADE AT FACE OF WALL. NO ADDITIONAL PAYMENT WILL BE ALLOWED FOR VARYING OF THE LEVELING PAD ELEVATION. THE ACTUAL TOPS OF LEVELING PADS SHALL BE DETERMINED BY THE CONTRACTOR TO PROVIDE SUPPORT FOR THE PROPOSED WALL SYSTEM AND SUBMITTED TO THE ENGINEER FOR APPROVAL.

ALL COST INCURRED DURING CONSTRUCTION OF THE M.S.E. RETAINING WALLS SHALL BE INCLUDED IN THE UNIT PRICE BID PER SQUARE YARD OF "M.S.E. RETAINING WALL". THE COST SHALL INCLUDE BUT NOT LIMITED TO: EXCAVATION, BACKFILL, BACKFILL MATERIAL, DRAINAGE SYSTEMS, GEOTEXTILES, FILTER FABRICS, PERFORATED AND NON-PERFORATED PIPE, CONCRETE, REINFORCING STEEL, SHEETING AND SHORING, DRIVING SHOES, COPING, EARTH REINFORCEMENT, CONCRETE PANELS, CONCRETE SURFACE FORM LINERS, FINISH, LEVELING PADS, CONCRETE MOW STRIPS, AND ENGINEERING AND ASSOCIATED COSTS.

DESIGN	
DRAWN	
CHECKED	
APPROVED	
SQUAD	POE

M.S.E. RETAINING WALL NOTES
RETAINING WALLS 'D2', 'F', 'G' & 'H'

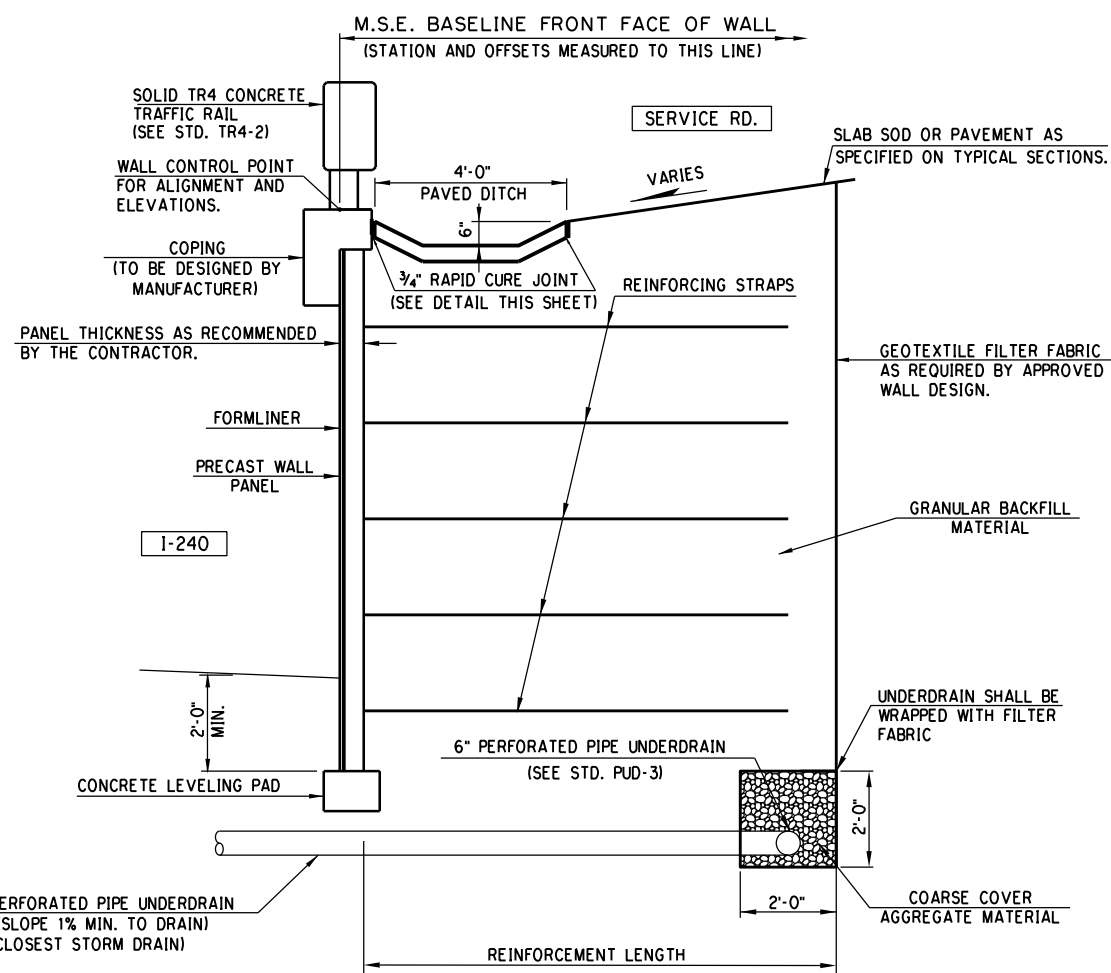

M.S.E. WALL 'D2' SECTION DETAIL

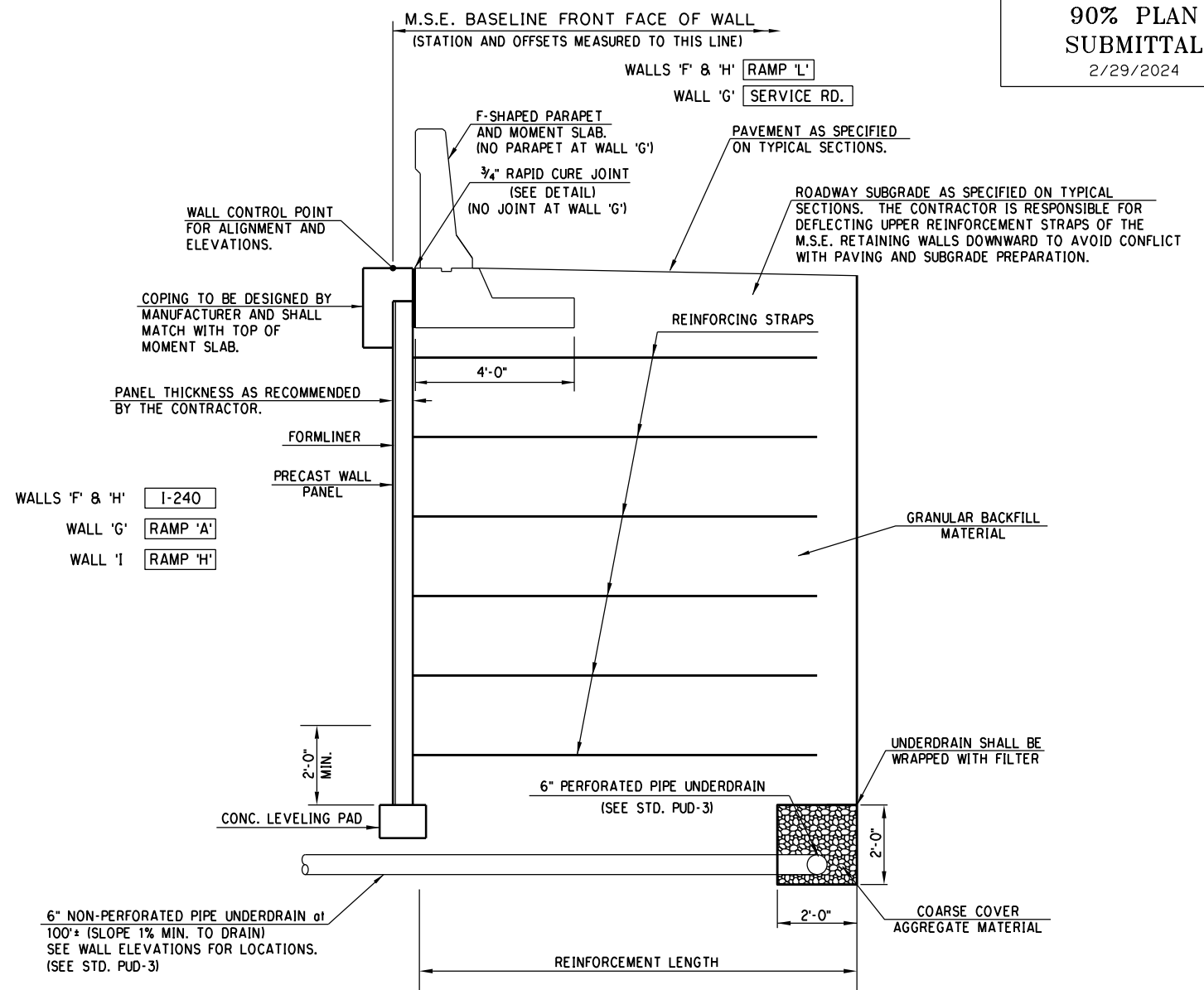

M.S.E. WALL 'F', 'G' & 'H' SECTION DETAILS

NOTE:
THE M.S.E. WALL PANELS SHALL BE STACKED AND MAY BE ERECTED IN A STAGGERED HORIZONTAL JOINT PATTERN.

ALL COST FOR WALL DRAINAGE SHALL BE IN PER SQUARE YARD FOR "MSE RETAINING WALL".

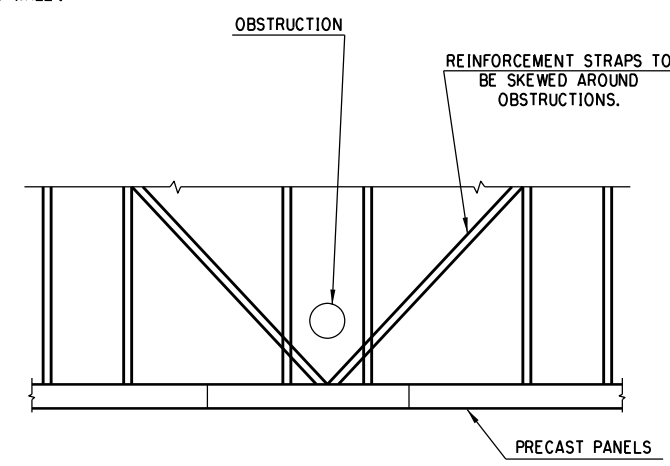

STRAP SKEWING PLAN DETAIL AT OBSTRUCTIONS

NOTE:
IF BARMAT OR WIRE MESH SOIL REINFORCEMENT IS USED, THEN A STRUCTURAL YOKE SYSTEM MUST BE ATTACHED TO THE OBSTRUCTED PANEL(S) AND THE OBSTRUCTED SECTIONS OF SOIL REINFORCEMENTS MUST BE ATTACHED TO THE YOKE ON THE BACKSIDE OF THE OBSTRUCTION.

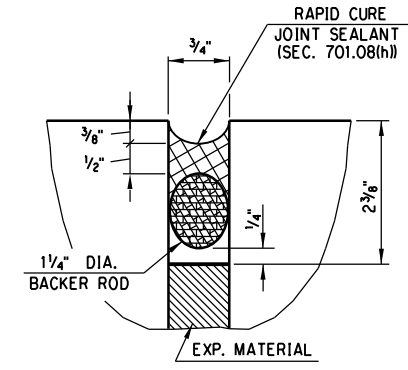

DETAIL OF RAPID CURE CURE JOINT

DESIGN	
DRAWN	
CHECKED	
APPROVED	
SQUAD	POE

PHASE 4 OKLAHOMA COUNTY

M.S.E. RETAINING WALL DETAILS
RETAINING WALL 'D2', 'F', 'G' & 'H'

STATE JOB NO. 09032108 SHEET NO. RW13

2/22/2024 5:45:11 PM H:\PROJECTS\2789_CrossRoads_Phase 4\Bridges\Drawings\Ph4 Walls\0903208 P4 MSE Wall Details.dgn

CURVE DATA RWI-2
 P.I. STA. 7+81.86
 N: 143043.1544
 E: 2152302.1616
 Δ = 7°50'10.17" LT.
 D = 5°51'31.99"
 T = 66.98'
 L = 133.75'
 R = 977.93'
 E = 2.29'

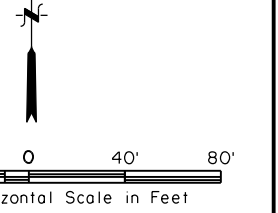
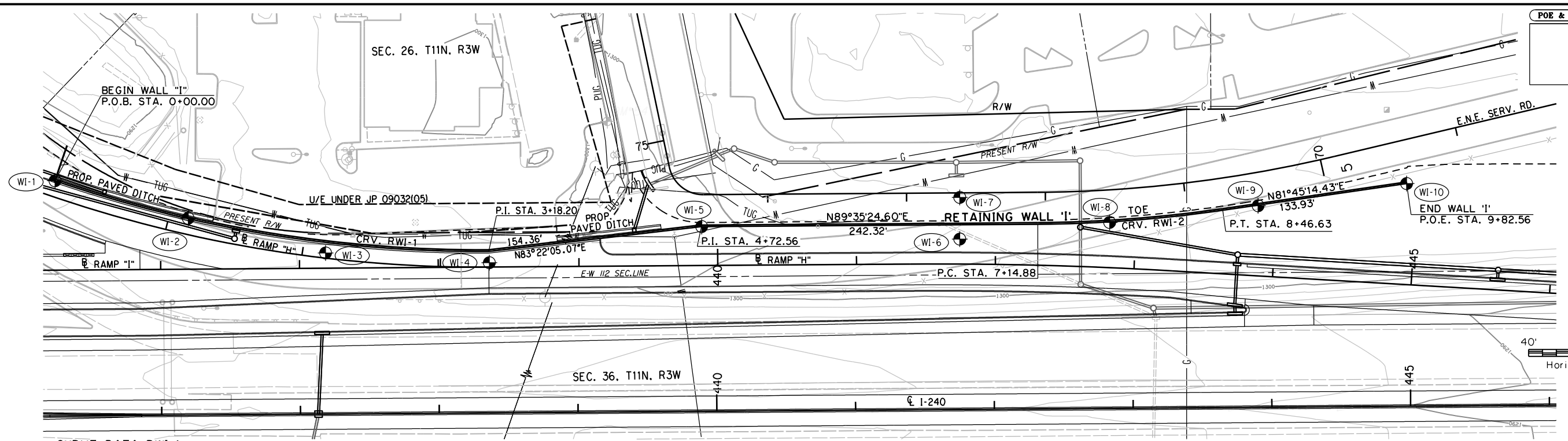

CURVE DATA RWI-1
 P.I. STA. 1+60.63
 N: 143021.9660
 E: 2151678.9262
 Δ = 19°19'12.07" LT.
 D = 6°04'18.19"
 T = 160.62'
 L = 318.20'
 R = 943.65'
 E = 13.57'

BM 54 ~ "X" ON TOP OF CURB IN EAST
 PARKING LOT TEXAS ROADHOUSE
 STA. 439+22.55 @ I-240, 209.30' LT.
 ELEV. = 1300.07

BM 53 ~ BAR & CAP (CONTROL POINT
 "O-55-184")
 STA. 444+45.20 @ I-240, 286.71' LT.
 ELEV. = 1308.47

BM 52 ~ "X" ON TOP OF CURB SOUTH OF
 LIGHT POLE SOUTHEAST OF THEATRE
 STA. 445+56.60 @ I-240, 308.74' LT.
 ELEV. = 1308.81

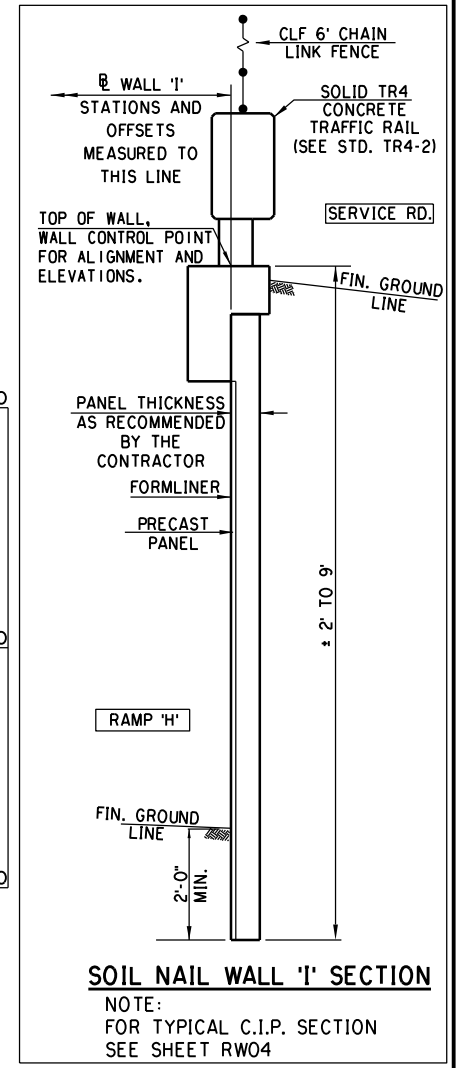
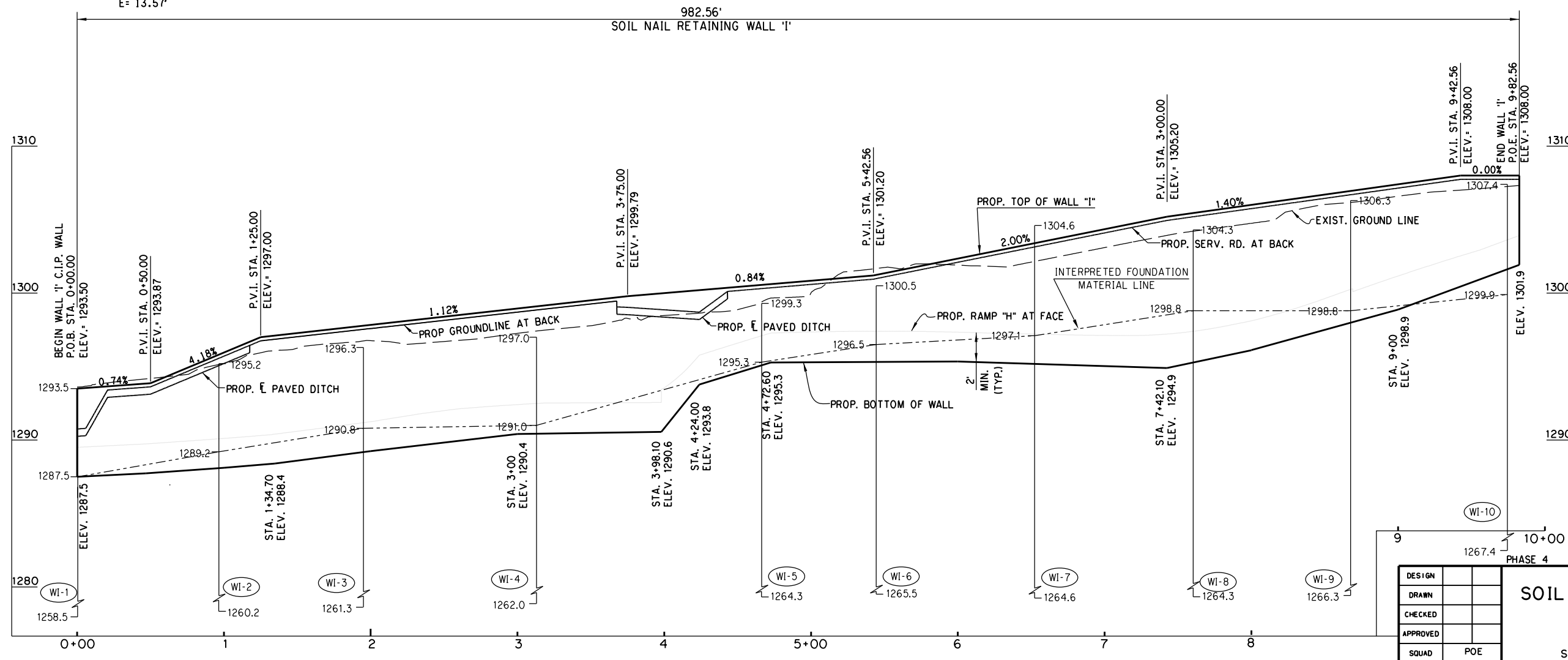

DESIGN	
DRAWN	
CHECKED	
APPROVED	
SQUAD	POE

**SOIL NAIL RETAINING WALL 'I'
PLAN & ELEVATION**

2/22/2024 5:45:13 PM H:\PROJECTS\2789_CrossRoads_Phase 4\Bridges\Drawings\Ph4 Walls\0903208 P4 Wall IPE.dgn

Boring Number WI-1
 Northing: 143074
 Easting: 2151527
 Date Drilled: 04/03/19

Boring Number WI-2
 Northing: 143047
 Easting: 2151623
 Date Drilled: 04/03/19

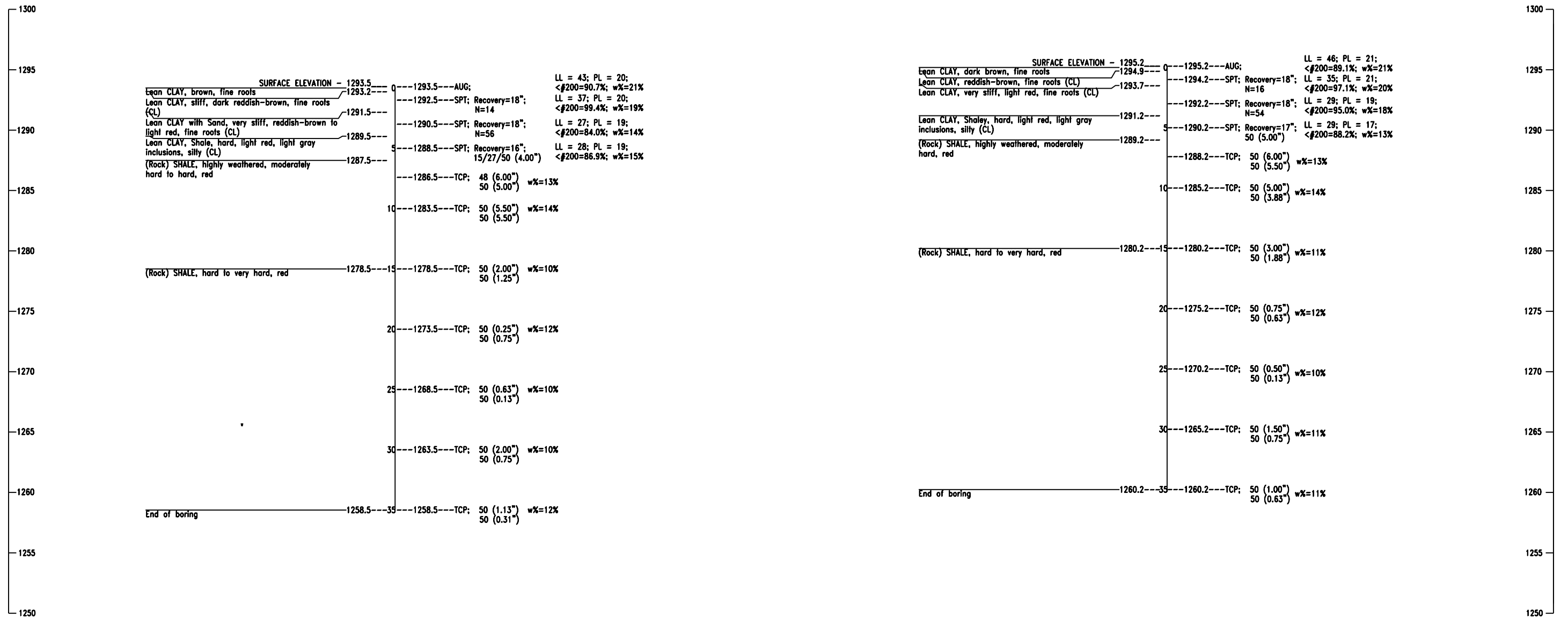

GEOLOGIC STATEMENT

"Division Four" of the "Engineering Classification of Geological Materials", published by the Oklahoma Department of Transportation (ODOT) indicates that the site is underlain by the Hennessey Unit (Phy). The geologic unit is described below.
 This unit consists of red platy to blocky clay shales and mudstone. The mudstones are hard and appear blocky. The red clay shale of the Hennessey Unit is characterized by numerous bands of streaks of white or light green color ranging from a few inches to four feet in thickness.
 The total thickness of the unit is about 400 feet.
 The Hennessey Unit outcrops in a 5- to 15-mile north-south band across Grant, Garfield, Kingfisher, Logan, Canadian, and Oklahoma Counties in Division Four. Topographically, the unit is near level to gently rolling and is generally grass covered or cultivated.

GEOTECHNICAL REPORT

All geotechnical information contained on this sheet is covered by the engineering seal affixed to an original geotechnical engineering report that has been stamped and sealed by a professional engineer licensed in Oklahoma. To obtain a copy of the complete report, contact the ODOT office engineer at (405) 521-2625. The contractor should be fully aware of the site conditions prior to beginning work. Any additional geotechnical information which may be desired is the responsibility of the contractor.

Note: Water level elevations shown were obtained at the time the borings were drilled and may fluctuate throughout the year.

NOTE: SPT - Split Spoon Sampling <#200 - Percent passing #200 sieve
 TCP - Texas Cone Penetator Test w% - Moisture content
 AUG - Augur Cutting Sample N - Number of blows per 12 inches
 LL - Liquid Limit
 PL - Plastic Limit
 * Denotes depth to observed groundwater

PHASE 4

OKLAHOMA COUNTY

DESIGN	
DRAWN	
CHECKED	
APPROVED	
SQUAD	PSI

FOUNDATION REPORT
 RETAINING WALL "I"
 (SHEET 1 OF 5)

STATE JOB NO. 09032(08) SHEET NO. RW15

Boring Number WI-3
Northing: 143022
Easting: 2151722
Date Drilled: 04/04/19

Boring Number WI-4
Northing: 143015
Easting: 2151840
Date Drilled: 04/04/19

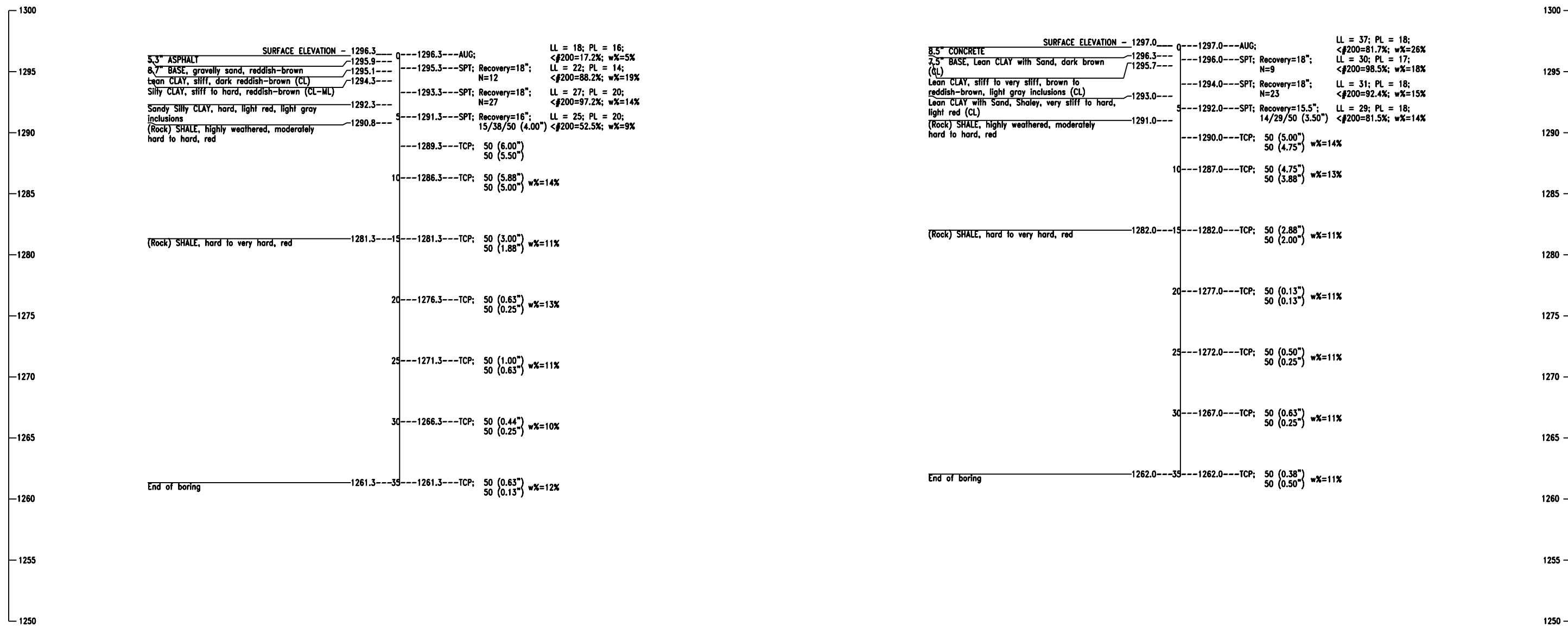

GEOLOGIC STATEMENT

"Division Four" of the "Engineering Classification of Geological Materials", published by the Oklahoma Department of Transportation (ODOT) indicates that the site is underlain by the Hennessey Unit (Phy). The geologic unit is described below. This unit consists of red platy to blocky clay shales and mudstone. The mudstones are hard and appear blocky. The red clay shale of the Hennessey Unit is characterized by numerous bands of streaks of white or light green color ranging from a few inches to four feet in thickness. The total thickness of the unit is about 400 feet. The Hennessey Unit outcrops in a 5- to 15-mile north-south band across Grant, Garfield, Kingfisher, Logan, Canadian, and Oklahoma Counties in Division Four. Topographically, the unit is near level to gently rolling and is generally grass covered or cultivated.

GEOTECHNICAL REPORT

All geotechnical information contained on this sheet is covered by the engineering seal affixed to an original geotechnical engineering report that has been stamped and sealed by a professional engineer licensed in Oklahoma. To obtain a copy of the complete report, contact the ODOT office engineer at (405) 521-2625. The contractor should be fully aware of the site conditions prior to beginning work. Any additional geotechnical information which may be desired is the responsibility of the contractor.

Note: Water level elevations shown were obtained at the time the borings were drilled and may fluctuate throughout the year.

NOTE: SPT - Split Spoon Sampling <#200 - Percent passing #200 sieve
TCP - Texas Cone Penetrometer Test w% - Moisture content
AUG - Augur Cutting Sample N - Number of blows per 12 inches
LL - Liquid Limit PL - Plastic Limit Denotes depth to observed groundwater

DESIGN	
DRAWN	
CHECKED	
APPROVED	
SQUAD	PSI

FOUNDATION REPORT
RETAINING WALL "I"
(SHEET 2 OF 5)

STATE JOB NO. 09032(08) SHEET NO. RW16

Boring Number WI-5
Northing: 143041
Easting: 2151993
Date Drilled: 03/30/19

Boring Number WI-6
Northing: 143032
Easting: 2152179
Date Drilled: 03/30/19

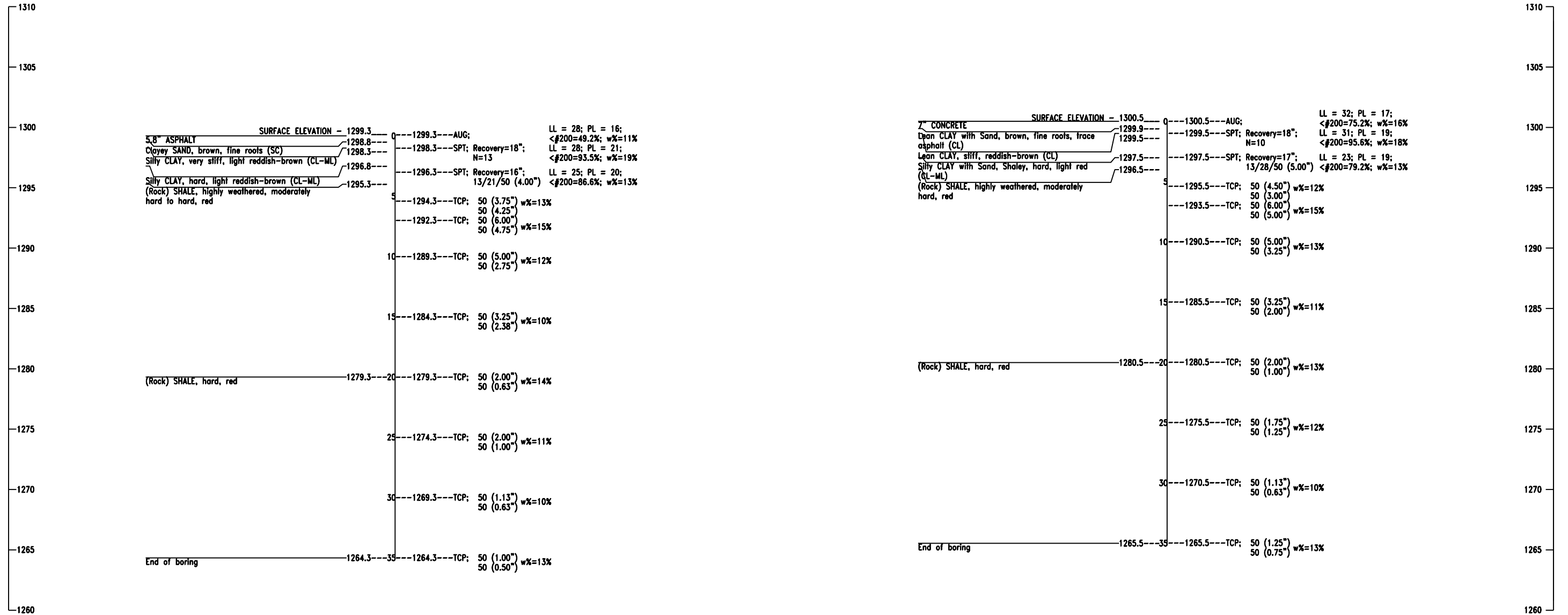

GEOLOGIC STATEMENT

"Division Four" of the "Engineering Classification of Geological Materials", published by the Oklahoma Department of Transportation (ODOT) indicates that the site is underlain by the Hennessey Unit (Phy). The geologic unit is described below.
This unit consists of red platy to blocky clay shales and mudstone. The mudstones are hard and appear blocky. The red clay shale of the Hennessey Unit is characterized by numerous bands of streaks of white or light green color ranging from a few inches to four feet in thickness.
The total thickness of the unit is about 400 feet.
The Hennessey Unit outcrops in a 5- to 15-mile north-south band across Grant, Garfield, Kingfisher, Logan, Canadian, and Oklahoma Counties in Division Four. Topographically, the unit is near level to gently rolling and is generally grass covered or cultivated.

GEOTECHNICAL REPORT

All geotechnical information contained on this sheet is covered by the engineering seal affixed to an original geotechnical engineering report that has been stamped and sealed by a professional engineer licensed in Oklahoma. To obtain a copy of the complete report, contact the ODOT office engineer at (405) 521-2625. The contractor should be fully aware of the site conditions prior to beginning work. Any additional geotechnical information which may be desired is the responsibility of the contractor.

Note: Water level elevations shown were obtained at the time the borings were drilled and may fluctuate throughout the year.

NOTE: SPT - Split Spoon Sampling <#200 - Percent passing #200 sieve
TCP - Texas Cone Penetator Test w% - Moisture content
AUG - Augur Cutting Sample N - Number of blows per 12 inches
LL - Liquid Limit * Denotes depth to observed groundwater
PL - Plastic Limit

PHASE 4

OKLAHOMA COUNTY

DESIGN	
DRAWN	
CHECKED	
APPROVED	
SQUAD	PSI

FOUNDATION REPORT
RETAINING WALL "I"
(SHEET 3 OF 5)

STATE JOB NO. 09032(08) SHEET NO. RW17

Boring Number WI-7
Northing: 143062
Easting: 2152179
Date Drilled: 04/02/19

Boring Number WI-8
Northing: 143044
Easting: 2152287
Date Drilled: 04/02/19

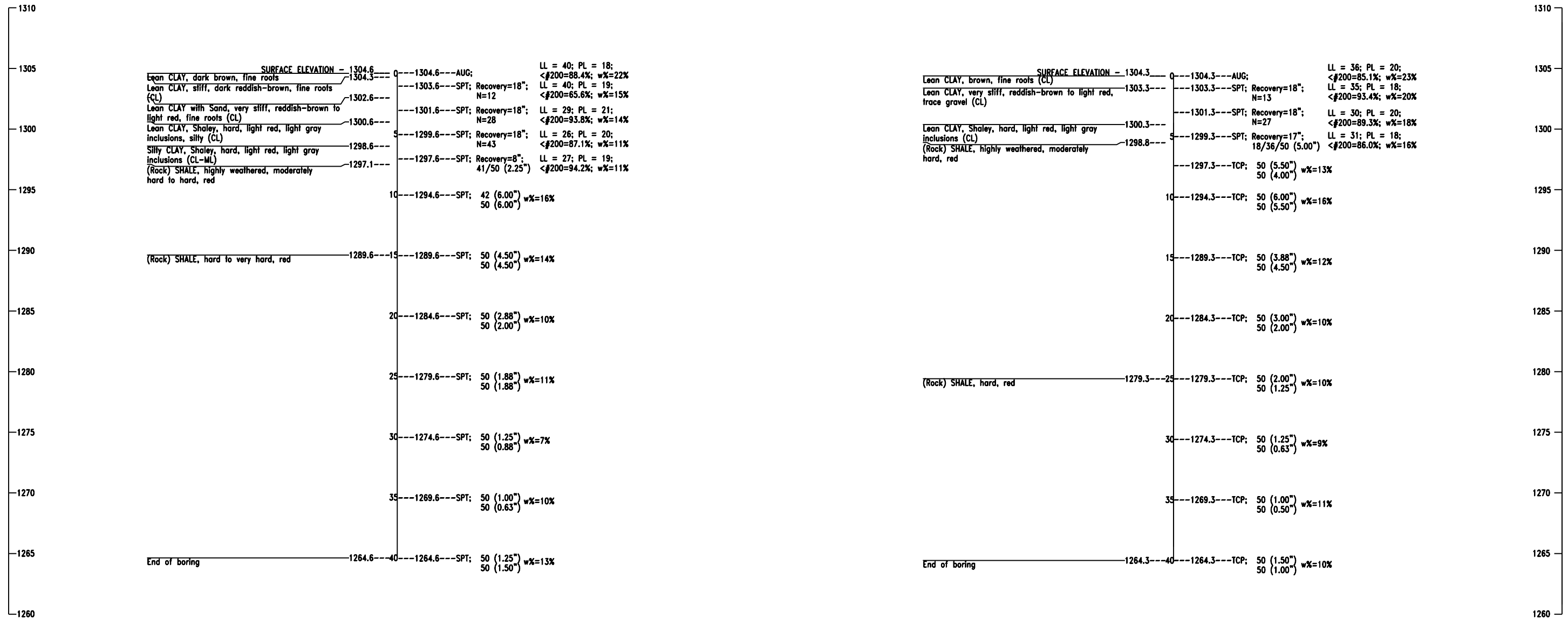

GEOLOGIC STATEMENT

"Division Four" of the "Engineering Classification of Geological Materials", published by the Oklahoma Department of Transportation (ODOT) indicates that the site is underlain by the Hennessey Unit (Phy). The geologic unit is described below.
This unit consists of red platy to blocky clay shales and mudstone. The mudstones are hard and appear blocky. The red clay shale of the Hennessey Unit is characterized by numerous bands of streaks of white or light green color ranging from a few inches to four feet in thickness.
The total thickness of the unit is about 400 feet.
The Hennessey Unit outcrops in a 5- to 15-mile north-south band across Grant, Garfield, Kingfisher, Logan, Canadian, and Oklahoma Counties in Division Four. Topographically, the unit is near level to gently rolling and is generally grass covered or cultivated.

GEOTECHNICAL REPORT

All geotechnical information contained on this sheet is covered by the engineering seal affixed to an original geotechnical engineering report that has been stamped and sealed by a professional engineer licensed in Oklahoma. To obtain a copy of the complete report, contact the ODOT office engineer at (405) 521-2625. The contractor should be fully aware of the site conditions prior to beginning work. Any additional geotechnical information which may be desired is the responsibility of the contractor.

Note: Water level elevations shown were obtained at the time the borings were drilled and may fluctuate throughout the year.

NOTE: SPT - Split Spoon Sampling <#200 - Percent passing #200 sieve
TCP - Texas Cone Penetrator Test w% - Moisture content
AUG - Augur Cutting Sample N - Number of blows per 12 inches
LL - Liquid Limit , Denotes depth to observed groundwater
PL - Plastic Limit

PHASE 4

OKLAHOMA COUNTY

DESIGN	
DRAWN	
CHECKED	
APPROVED	
SQUAD	PSI

FOUNDATION REPORT
RETAINING WALL "I"
(SHEET 4 OF 5)

STATE JOB NO. 09032(08) SHEET NO. RW18

Boring Number WI-9
Northing: 143056
Easting: 2152394
Date Drilled: 04/02/19

Boring Number WI-10
Northing: 143072
Easting: 2152501
Date Drilled: 04/02/19

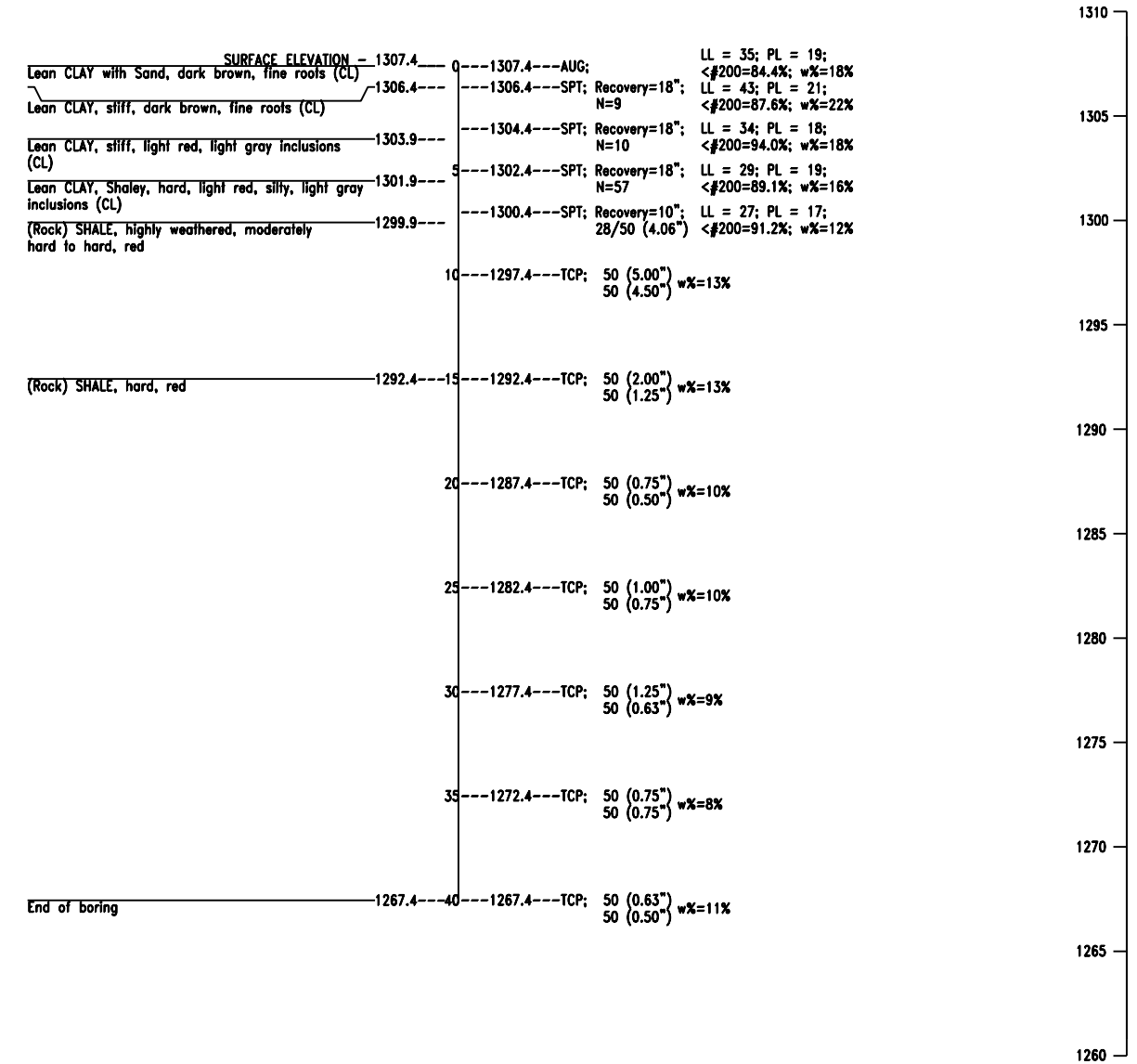
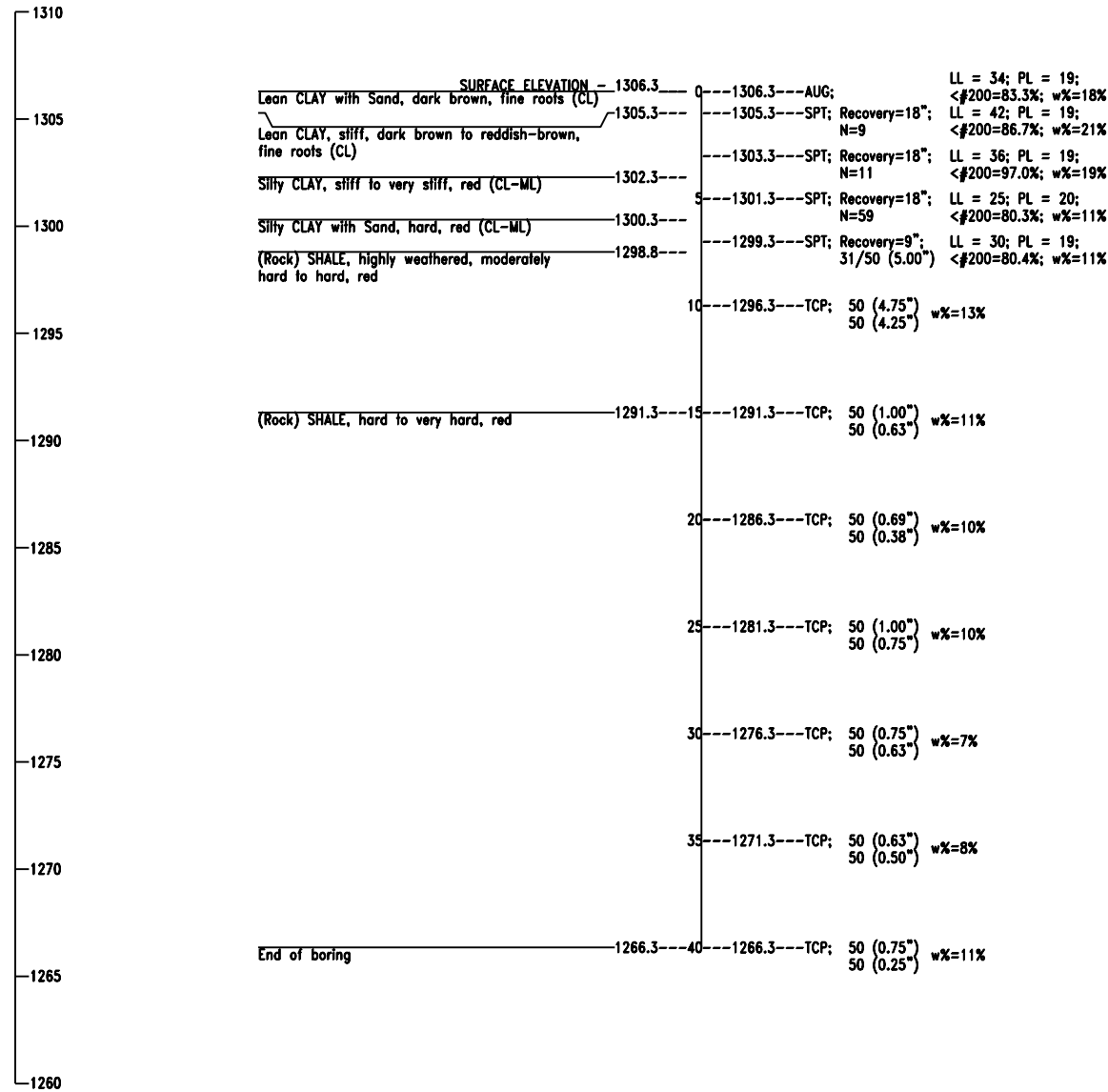

GEOLOGIC STATEMENT

"Division Four" of the "Engineering Classification of Geological Materials", published by the Oklahoma Department of Transportation (ODOT) indicates that the site is underlain by the Hennessey Unit (Phy). The geologic unit is described below.
This unit consists of red platy to blocky clay shales and mudstone. The mudstones are hard and appear blocky. The red clay shale of the Hennessey Unit is characterized by numerous bands of streaks of white or light green color ranging from a few inches to four feet in thickness.
The total thickness of the unit is about 400 feet.
The Hennessey Unit outcrops in a 5- to 15-mile north-south band across Grant, Garfield, Kingfisher, Logan, Canadian, and Oklahoma Counties in Division Four. Topographically, the unit is near level to gently rolling and is generally grass covered or cultivated.

GEOTECHNICAL REPORT

All geotechnical information contained on this sheet is covered by the engineering seal affixed to an original geotechnical engineering report that has been stamped and sealed by a professional engineer licensed in Oklahoma. To obtain a copy of the complete report, contact the ODOT office engineer at (405) 521-2625. The contractor should be fully aware of the site conditions prior to beginning work. Any additional geotechnical information which may be desired is the responsibility of the contractor.

Note: Water level elevations shown were obtained at the time the borings were drilled and may fluctuate throughout the year.

NOTE: SPT - Split Spoon Sampling <#200 - Percent passing #200 sieve
TCP - Texas Cone Penetrator Test w% - Moisture content
AUG - Augur Cutting Sample N - Number of blows per 12 inches
LL - Liquid Limit * Denotes depth to observed groundwater
PL - Plastic Limit

PHASE 4

OKLAHOMA COUNTY

DESIGN	
DRAWN	
CHECKED	
APPROVED	
SQUAD	PSI

FOUNDATION REPORT
RETAINING WALL "I"
(SHEET 5 OF 5)

STATE JOB NO. 09032(08) SHEET NO. RW19

GENERAL NOTES AND SOIL NAIL RETAINING WALL 'I' DESIGN PARAMETERS

- All design and evaluation procedures are according to the FHWA guidelines available in "The Manual for Design and Construction of Soil Nail Walls, Report No. FHWA-SA-96-069R" and "Geotechnical Engineering Circular No. 7 - Soil Nail Walls Reference Manual, Report No. FHWA-NHI-14-007."

All material and workmanship shall be in accordance with the requirements of the Oklahoma Department of Transportation 2019 Standard Specifications for Highway Construction and all Special Provisions and the Soil Nail Field Inspector's Manual, FHWA Publication No. SA-93-068.

This work shall consist of furnishing and constructing a permanent soil nail retaining wall system in accordance with this technical scope of work and in reasonably close conformity with the lines, grades, and dimensions shown on the Wall 'I' Construction Plans for the I-35/I-240 Interchange Reconstruction project.

- The soil nail wall structures have been designed in accordance with the LRFD (Load and Resistance Factor Design) procedures contained in the FHWA Geotechnical Engineering Circular No. 7 "Soil Nail Walls-Referenced Manual." Structural design of wall elements not covered in the FHWA manual have been designed in accordance with the requirements of the AASHTO Standard Specifications for Highway Bridges, 17th Edition, and latest interim specifications including the Guide Specifications for Seismic Design of Highway Bridges. A pseudo-static seismic acceleration coefficient of 0.10g was used in the design.
- Reinforced concrete and shotcrete: Reinforcing Steel: $f_y = 60$ ksi
Shotcrete: $f'_c = 4$ ksi
Nail grout: $f'_c = 4$ ksi
- Cast-in-place (CIP) Concrete Facing: Class AA Concrete ($f'_c = 4$ ksi). In accordance with the requirements of section 701.
- Reinforcing steel bar bends, hooks, lap splices, and embedment lengths shall conform with the requirements of ACI 318.
- Structural steel: AASHTO M-183/ASTM A36
- All construction materials and testing in accordance with the latest AASHTO and ASTM Specifications.
- Unless otherwise noted on the plans, minimum concrete/shotcrete cover measured from the face of concrete/shotcrete to the face of any reinforcing bar shall be as follows:

Front side of permanent facings exposed to weather: 2 in.
Permanent shotcrete facings exposed to soil: 3 in.
Permanent CIP facings cast against temporary shotcrete: 1.5 in.

- Unless otherwise noted on the plans, all exterior corners and edges shall have a 3/4 in. fillet.
- Design Soil Parameters:

WALL 'I' STATION LIMITS	DEPTH (FT.)	SOIL/ROCK TYPE	EFFECTIVE FRICTION ANGLE (DEGREES) ϕ'	EFFECTIVE COHESION (PSF) c'	EFFECTIVE UNIT WEIGHT (PCF) γ'	NOMINAL PULLOUT RESISTANCE (LB./FT.)
	0-6	LEAN CLAY	-	2,100	120	2,400
0+00.00 TO 9+82.56	6-8	SHALEY CLAY	-	4,100	125	2,400+
	8+	SHALE	-	7,500	135	2,400+

WALL-SOIL INTERFACE FRICTION ANGLE, $\delta = 2/3(\phi)$

- All nail drilled lengths (L) and bar sizes shall be in accordance with Soil Nail Retaining Wall 'I' Layout Sheets.
- The Contractor is responsible for field locating all utilities.
- The Contractor is responsible for providing and maintaining stable slopes above and below the soil nail walls.
- No general excavation open cuts steeper than 1H:1V shall be made within 15 feet in front of the soil nail walls without approval of the Engineer.
- Where grade slopes away from the back of the wall, the concrete drainage gutter shall not be required.
- The contractor shall be responsible for survey control as excavation proceeds from the top-down. See special provisions.
- At the contractor's option, nails may be drilled and installed through a temporary stabilizing berm (if needed).
- Excavation in the vicinity of the wall face requires special care and effort compared to general roadway excavation. See special provisions and sheet no. [REDACTED]
- Soil nail lengths are drilled lengths, actual total nail bar lengths shall be greater than the drilled lengths, See sheet no. [REDACTED]

SOIL NAIL WALL QUANTITIES

Quantities shown below are for informational purposes only. The payment for the Soil Nail Wall shall be based on the surface area shown on the Plan and Profile sheets. All associated wall costs incurred during construction of the Soil Nail Wall shall be included in the unit price bid per square yard of "Retaining Wall".

ITEM NO.	ITEM	UNITS	WALL 'I' TOTALS
1	VERIFICATION TEST NAILS	EA.	6
2	NAILS, ENCAPSULATED, 4' LONG	EA.	96
3	NAILS, ENCAPSULATED, 7' LONG	EA.	443
4	NAILS, ENCAPSULATED, 10' LONG	EA.	316
5	SHOTCRETE CONSTRUCTION FACING (4" THICK)	S.F.	7,300
6	CIP CONCRETE FACING FOR SOIL NAIL WALLS (8" THICK)	S.F.	7,870
7	BEARING PLATES (8"x8"x1")	EA.	861

TYPICAL CONSTRUCTION SEQUENCE

- Walls shall be built from the top down in accordance with the staged excavation lifts shown on Sheet no. [REDACTED] and the Special Provisions.
- The following wall construction sequence for each excavation lift shall be complete prior to initiating work on the next excavation lift unless otherwise approved by the Engineer.
 - Install pre-production verification test nails.
 - Excavate to stage 1 rough grade.
 - Trim to final wall face excavation line or to stabilization berm (if used).
 - Drill, install and grout nails. Trim stabilization berm (if used) to final wall face excavation line.
 - Install geocomposite drainage strip.
 - Place reinforcing and apply shotcrete construction facing upon completion of the excavation lift. No excavation shall be left unstabilized (without shotcrete) at the end of the work day unless Engineer approves otherwise.
 - Perform nail pullout tests per specifications after shotcrete and nail grout have attained their specified strengths.
- Install PVC connector pipes during construction of the final shotcrete lift to provide drainage of the geocomposite drainage strips into the footing drain or wall base as shown on sheet no. [REDACTED]
- Following completion of the full height shotcrete construction facing, place reinforcing steel and concrete for cast-in-place concrete wall facing and apply architectural finish. See sheet nos. [REDACTED] and [REDACTED] for reference.
- Special Paved ditch behind the finished soil nail walls will be constructed by the Roadway Contractor.
- If applicable or when present, existing concrete slope wall shall be saw cut along a straight line at the location of the shotcrete or 4' special paved ditch, as applicable. Leave approximately 1.0 foot of reinforcing steel exposed for embedment into shotcrete and CIP, and the special paved ditch, when applicable.

MATERIALS:

- Proportion nail grout and shotcrete to have minimum 28-day compressive strength of 4 ksi.
- Use of ASTM A36 steel or AASHTO equivalent for bearing plates. All steel or steel assemblies shall be hot-dipped galvanized for corrosion protection.
- Use of ASTM A307 steel or AASHTO equivalent.
- Use deformed or all-thread GR 60, ASTM A615 or AASHTO for nail bars. All nail bars shall be encapsulated or epoxy-coated for corrosion protection.
- Tolerances for concrete and the fabrication and placing of reinforcement shall conform to AASHTO requirements.
- Use welded wire mesh fabric per AASHTO M55, ASTM-A185 or A497. Deformed reinforcing bars in construction and shotcrete facing: ASTM A615 GR 60.

SOIL NAIL INSTALLATION:

- Verification:** Dimensions and locations of existing and future structures shall be verified prior to fabrication and installation of the soil nails. Notify the engineer about any discrepancies in dimensions.
- Soil Nail Tolerances:** Plan location < 6 inches, and orientation < 3 degrees.
- Hole Drilling:** Soil Nail holes shall be drilled without loss of ground and without endangering previously installed soil nails. This may involve casing the holes or other methods of protection from caving. The contractor shall select the drilling and grouting methods necessary to meet these requirements.
- Grouting:** Following drilling, the bar shall be placed into the hole and grouted from the bottom of the hole to the surface in one continuous operation. Continuously agitate grout and deliver grout to hole free from lumps and undispersed cement. Control pressure to prevent soil heave.
- Quality Control:** Systematic program of observation shall be conducted during the project execution to determine the effort of construction on adjacent nails in order to protect them from damage. Communication between holes as evidence by grout eruptions shall not be allowed and will require modification of the drilling methods.
- Special Provisions:** A.) The Contractor shall be responsible for the cost of all means of subsoil improvement; cost of additional subsoil exploration; and for all labor, tools, equipment and incidentals necessary to complete the work. Facing stabilization during excavation and any measures necessary for stability of the soil nail during construction are incidental. B.) The Contractor shall be responsible for complying with all Federal, State and Local building inspection and current OSHA excavation regulations. C.) Verify all dimensions and grades prior to wall construction and notify the Engineer of discrepancies.

INSPECTION AND MONITORING:

- The drilling contractor shall endeavor to cooperate with the inspecting and testing agencies selected by the owner, and shall furnish equipment, tools and labor on site as required to facilitate such tasks.
- Drilling contractor shall take photographs to document condition of adjacent existing structures, walls, pavements, utilities, etc. prior to commencement of work. One set of such photos shall be submitted to the engineer before starting work.
- Monitoring of ground settlement and soil nail wall movement shall be surveyed by the general contractor.
- Should excessive or sudden increase of ground settlement or soil nail wall movement be detected, the shoring contractor shall notify engineer and general contractor immediately.
- The Soil Nail lengths have been designed for clay soil materials and underlying shale in the cuts. Observations should be made during construction by the Engineer of record to evaluate that nails are embedded in the assumed material. If materials are found to be different than in the design, PSI designers should be advised and asked to reevaluate the designed lengths and patterns before installing nails.

CONCRETE SURFACE TREATMENT:

The textured surfaces will have an average vertical relief of 3/4". Provide "Fracture Granite" or other Engineer specified appearance as produced by using form liners manufactured by Architectural Polymers or Symons Corporation, or other Engineer approved manufacturer.

The form lining material shall be full sized commercial panels and joints shall be lined up, in so far as is practical, no scrap or odd sized pieces will be used. Provisions will be made in adjustment of forms to correct any deformations. Form liners must be sealed at all ends, edges, joints, and tie holes to prevent discoloration, sandstreaking and fins on concrete surfaces. All chamfer strips for V-grooves must be well oiled to facilitate stripping. As soon as forms are removed, all discontinuity of relief pattern, particularly at panel butt joints, shall be dressed in a manner approved by the engineer.

The contractor will furnish the engineer with a 12"x18" sample panel finished in the manner the concrete wall treatment is to be finished for approval.

All costs of concrete wall treatment including finished form liners, labor, materials, tools, and incidentals necessary to complete the work as specified shall be included in other items of work.

DESIGN	AIO	03/24
DRAWN	UH	03/24
CHECKED		
APPROVED		
SQUAD	GEOCAL	

SOIL NAIL RETAINING WALL 'I' SPECIFICATIONS



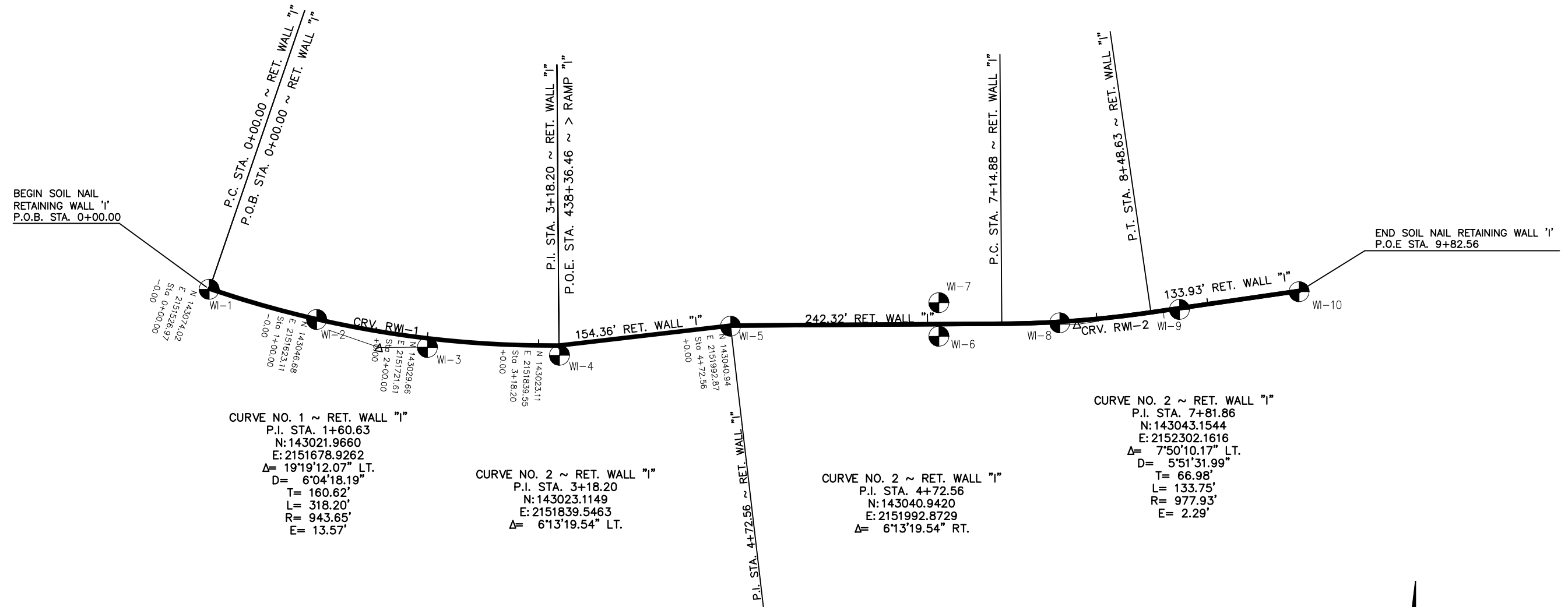

CURVE NO. 1 ~ RET. WALL "I"
 P.I. STA. 1+60.63
 N: 143021.9660
 E: 2151678.9262
 Δ= 19°19'12.07" LT.
 D= 6'04"18.19"
 T= 160.62'
 L= 318.20'
 R= 943.65'
 E= 13.57'

CURVE NO. 2 ~ RET. WALL "I"
 P.I. STA. 3+18.20
 N: 143023.1149
 E: 2151839.5463
 Δ= 6°13'19.54" LT.

CURVE NO. 2 ~ RET. WALL "I"
 P.I. STA. 4+72.56
 N: 143040.9420
 E: 2151992.8729
 Δ= 6°13'19.54" RT.

CURVE NO. 2 ~ RET. WALL "I"
 P.I. STA. 7+81.86
 N: 143043.1544
 E: 2152302.1616
 Δ= 7°50'10.17" LT.
 D= 5'51"31.99"
 T= 66.98'
 L= 133.75'
 R= 977.93'
 E= 2.29'

APPROXIMATE BORING LOCATIONS		
BORING NO.	NORTHING	EASTING
WI-01	143074	2151527
WI-02	143047	2151623
WI-03	143022	2151722
WI-04	143015	2151840
WI-05	143041	2151993
WI-06	143032	2152071
WI-07	143062	2152179
WI-08	143044	2152287
WI-09	143056	2152394
WI-10	143072	2152501

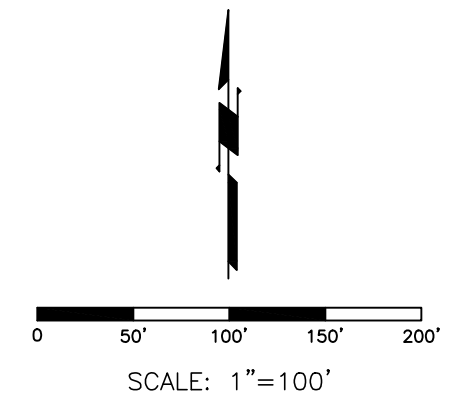

DESIGN	AIG	03/24
DRAWN	UH	03/24
CHECKED		
APPROVED		
SQUAD	GEOCAL	

PHASE 4 OKLAHOMA COUNTY

SOIL NAIL RETAINING WALL 'I'
 HORIZONTAL ALIGNMENT
 LAYOUT

STATE JOB NO. 09032(08) SHEET NO. RW21

SOIL NAIL RETAINING WALL 'I' OVERALL LENGTH = 982.56' (2)

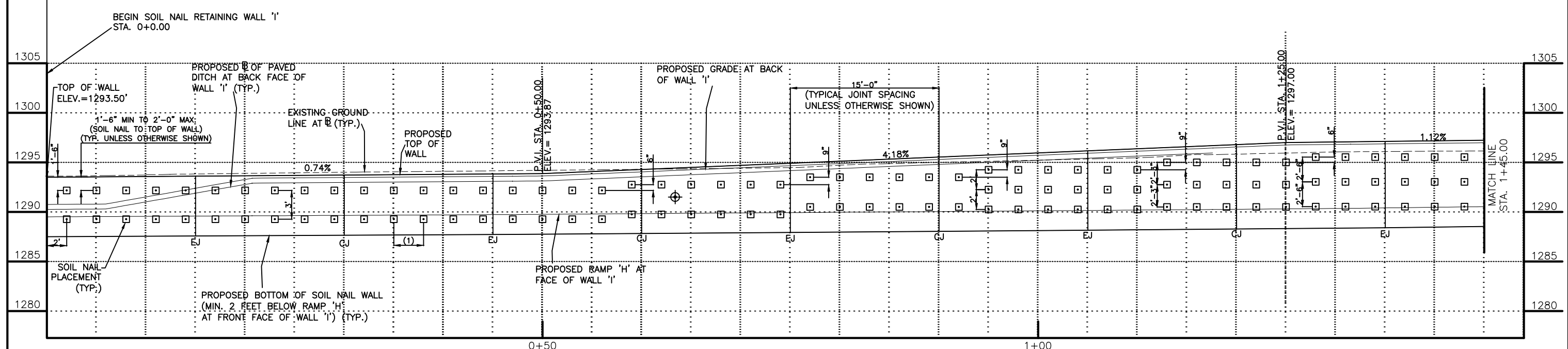

- (1) 3'-0" SPACING BETWEEN SOIL NAILS, UNLESS OTHERWISE SHOWN (TYP.)
- (2) THE LENGTH OF WALL 'I' IS MEASURED ALONG THE B (FRONT FACE OF WALL).

SOIL NAIL RETAINING WALL 'I' ELEVATION

SOIL NAIL RETAINING WALL 'I' OVERALL LENGTH = 982.56' (2)

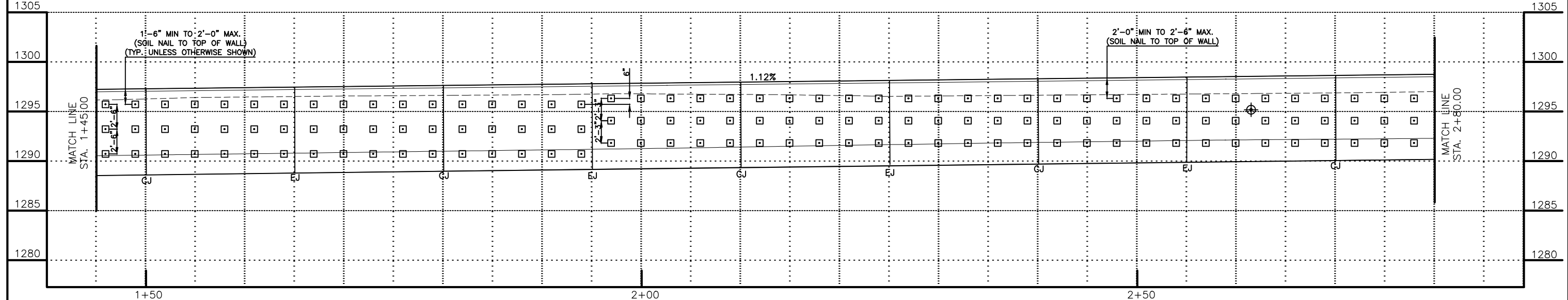

SOIL NAIL RETAINING WALL 'I' ELEVATION

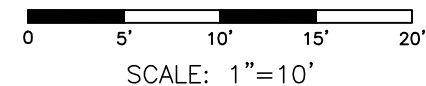

NOTES:

TOP OF WALL ELEVATIONS SHOWN ARE AT THE TOP OF THE SOIL NAIL WALL (PERMANENT FACING).

JOINTS SHALL BE LOCATED PRIOR TO THE INSTALLATION OF THE SOIL NAILS AND SHALL NOT CONFLICT WITH SOIL NAIL LOCATIONS.

LEGEND	
□	SOIL NAIL
⊕	VERIFICATION SOIL NAIL
L	DRILLED LENGTH OF NAIL
AD	DESIGN NAIL ADHESION
δ	NAIL INCLINATION FROM HORIZONTAL
D	DRILL HOLE DIAMETER
EJ	EXPANSION JOINT
CJ	CONTRACTION JOINT

SOIL NAIL SCHEDULE						
B WALL 'I' STATION LIMITS	L	BAR #	AD (PSI)	δ	D	
0+00.00 TO 1+25.00	7'	8	8	15°	8"	
1+25.00 TO 3+98.00	7'	8	8	15°	8"	
3+98.00 TO 5+42.56	4'	8	8	15°	8"	
5+42.56 TO 6+42.50	7'	8	8	15°	8"	
6+42.50 TO 7+42.10	10'	8	8	15°	8"	
7+42.10 TO 9+82.56	10'	8	8	15°	8"	

PHASE 4 OKLAHOMA COUNTY

DESIGN	AIO	03/24
DRAWN	UH	03/24
CHECKED		
APPROVED		
SQUAD	GEOCAL	

SOIL NAIL RETAINING WALL 'I' LAYOUT

(SHEET 1 OF 4)

STATE JOB NO. 09032(08) SHEET NO. RW22



SOIL NAIL RETAINING WALL 'I' OVERALL LENGTH = 982.56' (2)

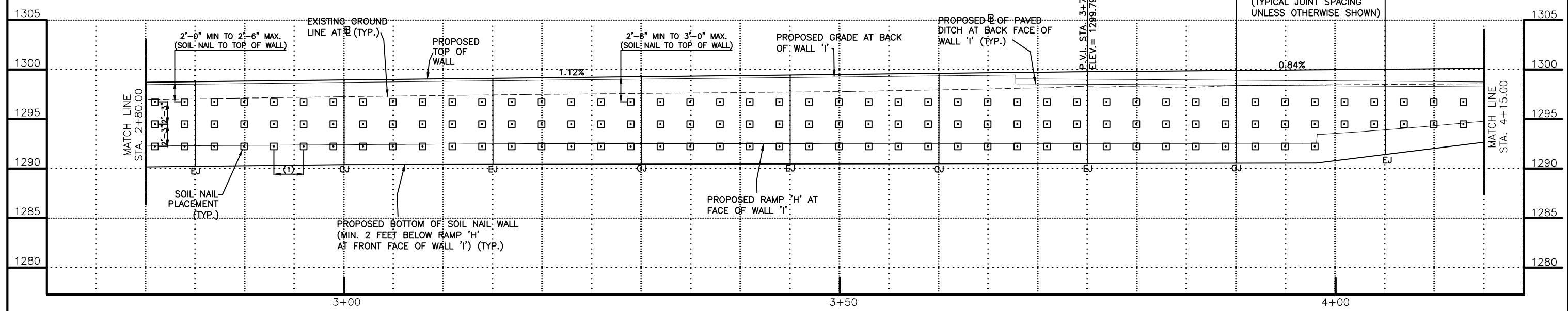

- (1) 3'-0" SPACING BETWEEN SOIL NAILS, UNLESS OTHERWISE SHOWN (TYP.)
- (2) THE LENGTH OF WALL 'L' IS MEASURED ALONG THE \mathbb{E} (FRONT FACE OF WALL).

SOIL NAIL RETAINING WALL 'I' ELEVATION

SOIL NAIL RETAINING WALL 'I' OVERALL LENGTH = 982.56' (2)

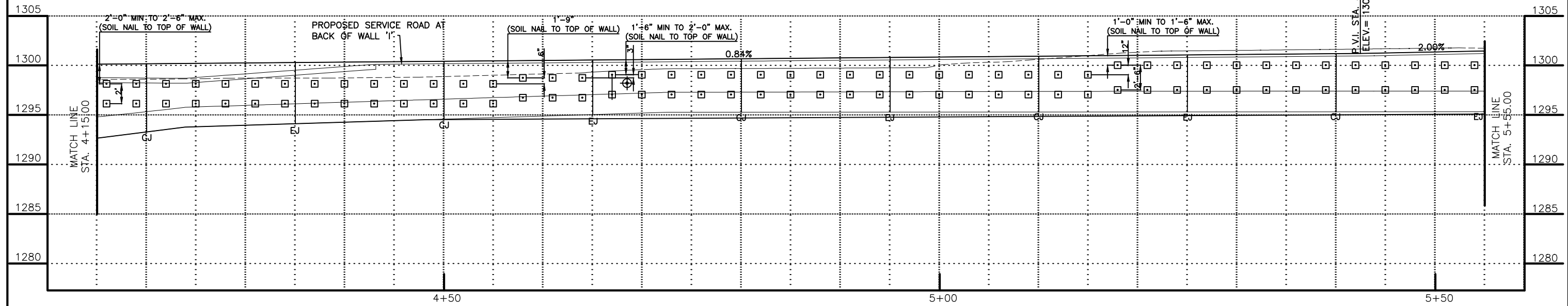

SOIL NAIL RETAINING WALL 'I' ELEVATION

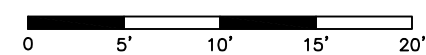

SCALE: 1"=10'

NOTES:

TOP OF WALL ELEVATIONS SHOWN ARE AT THE TOP OF THE SOIL NAIL WALL (PERMANENT FACING).

JOINTS SHALL BE LOCATED PRIOR TO THE INSTALLATION OF THE SOIL NAILS AND SHALL NOT CONFLICT WITH SOIL NAIL LOCATIONS.

LEGEND	
\square	SOIL NAIL
\oplus	VERIFICATION SOIL NAIL
L	DRILLED LENGTH OF NAIL
AD	DESIGN NAIL ADHESION
δ	NAIL INCLINATION FROM HORIZONTAL
D	DRILL HOLE DIAMETER
EJ	EXPANSION JOINT
CJ	CONTRACTION JOINT

SOIL NAIL SCHEDULE						
\mathbb{E} WALL 'I' STATION LIMITS	L	BAR #	AD (PSI)	δ	D	
0+00.00 TO 1+25.00	7'	8	8	15°	8"	
1+25.00 TO 3+98.00	7'	8	8	15°	8"	
3+98.00 TO 5+42.56	4'	8	8	15°	8"	
5+42.56 TO 6+42.50	7'	8	8	15°	8"	
6+42.50 TO 7+42.10	10'	8	8	15°	8"	
7+42.10 TO 9+82.56	10'	8	8	15°	8"	



DESIGN	AIO	03/24
DRAWN	UH	03/24
CHECKED		
APPROVED		
SQUAD	GEOCAL	

PHASE 4 OKLAHOMA COUNTY

SOIL NAIL RETAINING WALL 'I' LAYOUT (SHEET 2 OF 4)

STATE JOB NO. 09032(08) SHEET NO. RW23

SOIL NAIL RETAINING WALL 'I' OVERALL LENGTH = 982.56' (2)

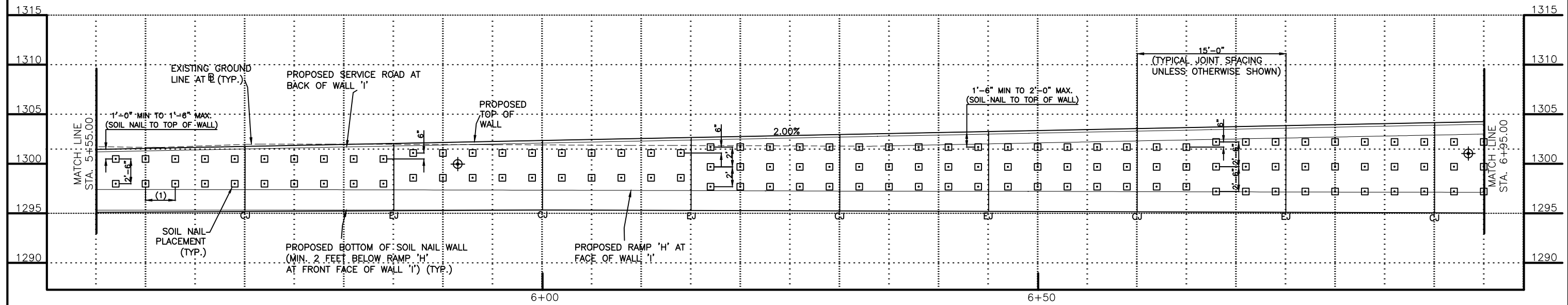

- (1) 3'-0" SPACING BETWEEN SOIL NAILS, UNLESS OTHERWISE SHOWN (TYP.)
 (2) THE LENGTH OF WALL 'L' IS MEASURED ALONG THE E (FRONT FACE OF WALL).
 SOIL NAIL RETAINING WALL 'I' ELEVATION

SOIL NAIL RETAINING WALL 'I' OVERALL LENGTH = 982.56' (2)

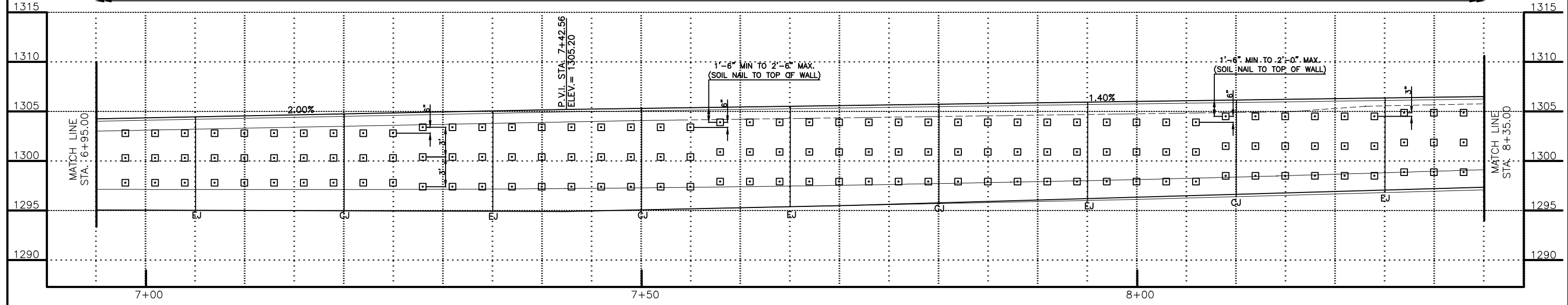

SOIL NAIL RETAINING WALL 'I' ELEVATION

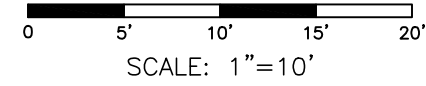

NOTES:

TOP OF WALL ELEVATIONS SHOWN ARE AT THE TOP OF THE SOIL NAIL WALL (PERMANENT FACING).

JOINTS SHALL BE LOCATED PRIOR TO THE INSTALLATION OF THE SOIL NAILS AND SHALL NOT CONFLICT WITH SOIL NAIL LOCATIONS.

LEGEND	
□	SOIL NAIL
⊕	VERIFICATION SOIL NAIL
L	DRILLED LENGTH OF NAIL
AD	DESIGN NAIL ADHESION
δ	NAIL INCLINATION FROM HORIZONTAL
D	DRILL HOLE DIAMETER
EJ	EXPANSION JOINT
CJ	CONTRACTION JOINT

SOIL NAIL SCHEDULE						
WALL 'I' STATION LIMITS	L	BAR #	AD (PSI)	δ	D	
0+00.00 TO 1+25.00	7'	8	8	15°	8"	
1+25.00 TO 3+98.00	7'	8	8	15°	8"	
3+98.00 TO 5+42.56	4'	8	8	15°	8"	
5+42.56 TO 6+42.50	7'	8	8	15°	8"	
6+42.50 TO 7+42.10	10'	8	8	15°	8"	
7+42.10 TO 9+82.56	10'	8	8	15°	8"	

PHASE 4 OKLAHOMA COUNTY

DESIGN	AIO	03/24
DRAWN	UH	03/24
CHECKED		
APPROVED		
SQUAD	GEOCAL	

SOIL NAIL RETAINING WALL 'I' LAYOUT
(SHEET 3 OF 4)

STATE JOB NO. 09032(08) SHEET NO. RW24



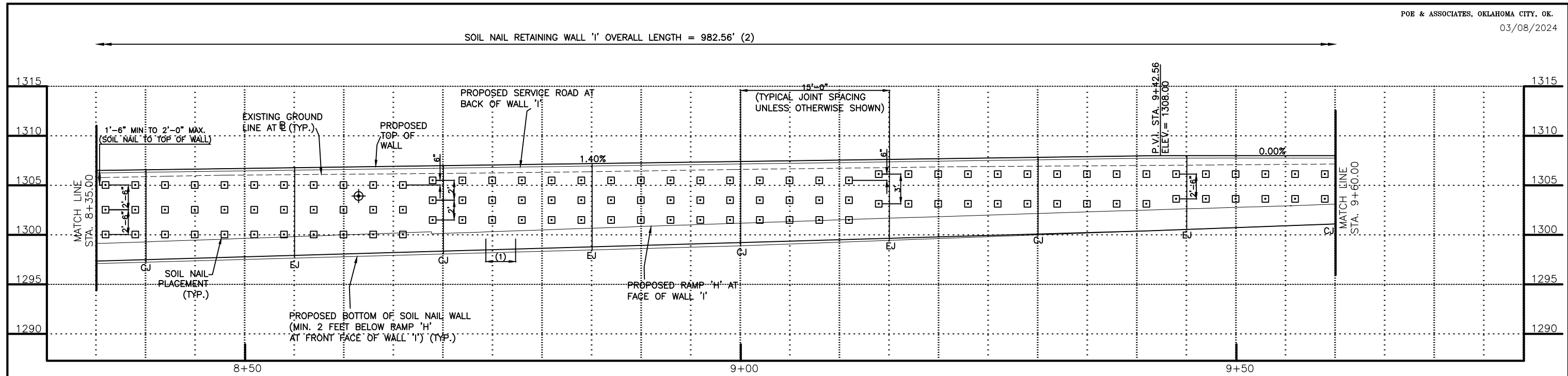

(1) 3'-0" SPACING BETWEEN SOIL NAILS, UNLESS OTHERWISE SHOWN (TYP.) THE LENGTH OF WALL 'L' IS MEASURED ALONG THE \mathbb{E} (FRONT FACE OF WALL). SOIL NAIL RETAINING WALL 'I' ELEVATION

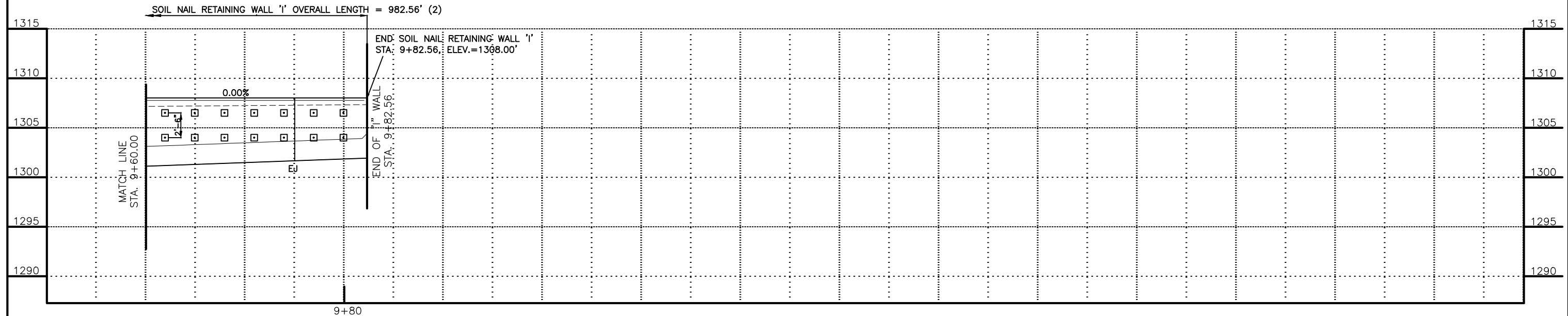

SOIL NAIL RETAINING WALL 'I' ELEVATION

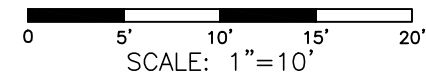

NOTES:
TOP OF WALL ELEVATIONS SHOWN ARE AT THE TOP OF THE SOIL NAIL WALL (PERMANENT FACING). JOINTS SHALL BE LOCATED PRIOR TO THE INSTALLATION OF THE SOIL NAILS AND SHALL NOT CONFLICT WITH SOIL NAIL LOCATIONS.

LEGEND	
\square	SOIL NAIL
\oplus	VERIFICATION SOIL NAIL
L	DRILLED LENGTH OF NAIL
AD	DESIGN NAIL ADHESION
δ	NAIL INCLINATION FROM HORIZONTAL
D	DRILL HOLE DIAMETER
EJ	EXPANSION JOINT
CJ	CONTRACTION JOINT

SOIL NAIL SCHEDULE						
\mathbb{E} WALL 'I' STATION LIMITS	L	BAR #	AD (PSI)	δ	D	
0+00.00 TO 1+25.00	7'	8	8	15°	8"	
1+25.00 TO 3+98.00	7'	8	8	15°	8"	
3+98.00 TO 5+42.56	4'	8	8	15°	8"	
5+42.56 TO 6+42.50	7'	8	8	15°	8"	
6+42.50 TO 7+42.10	10'	8	8	15°	8"	
7+42.10 TO 9+82.56	10'	8	8	15°	8"	



PHASE 4 OKLAHOMA COUNTY

DESIGN	AIO	03/24
DRAWN	UH	03/24
CHECKED		
APPROVED		
SQUAD	GEOCAL	

SOIL NAIL RETAINING WALL 'I' LAYOUT
(SHEET 4 OF 4)

STATE JOB NO. 09032(08) SHEET NO. RW25

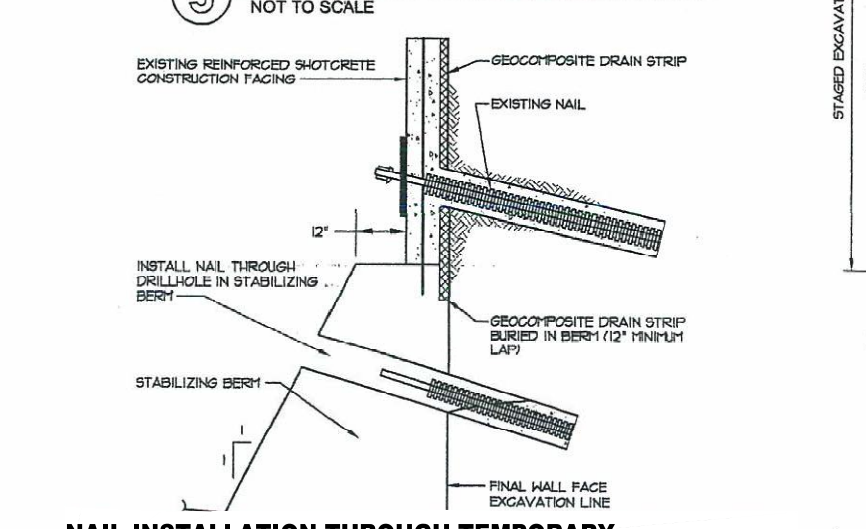
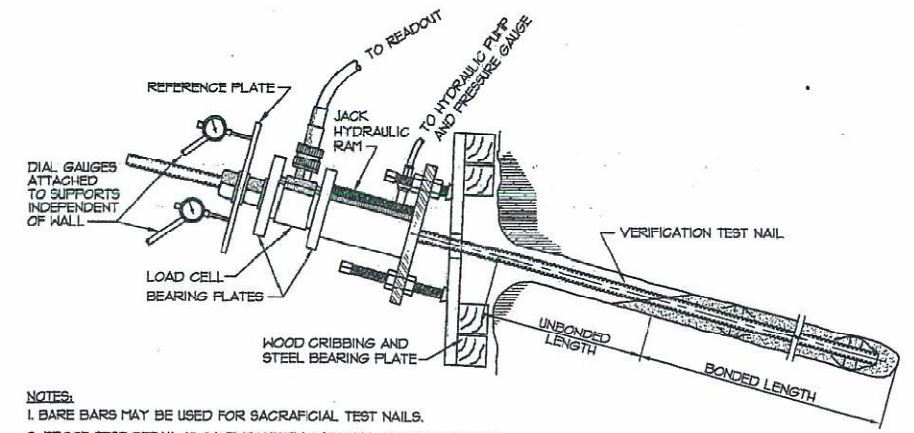
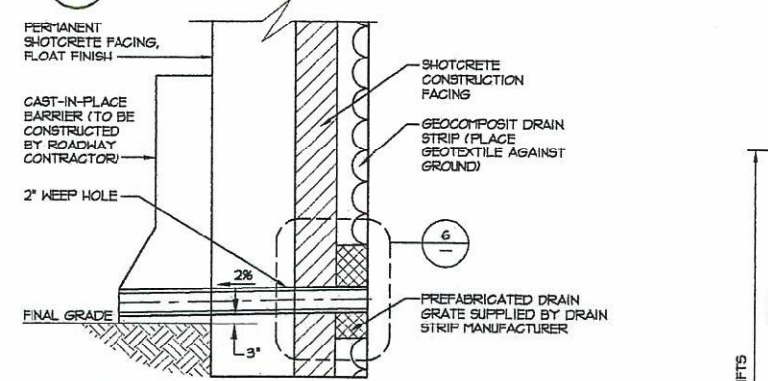
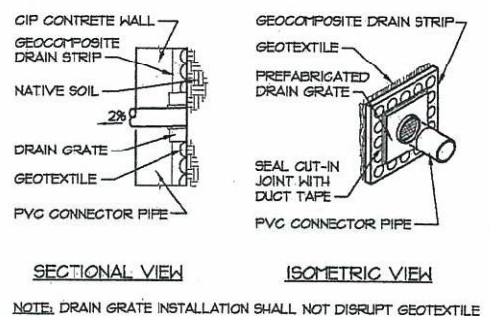
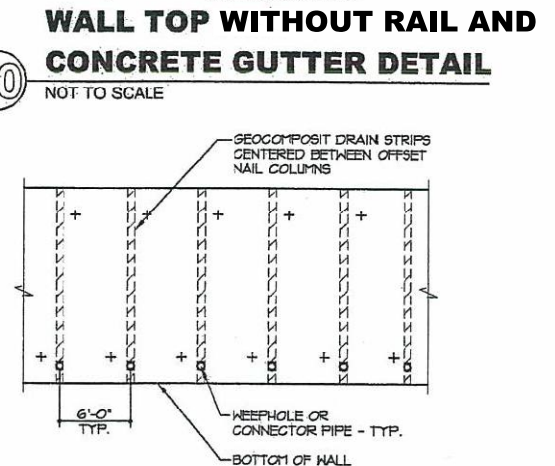
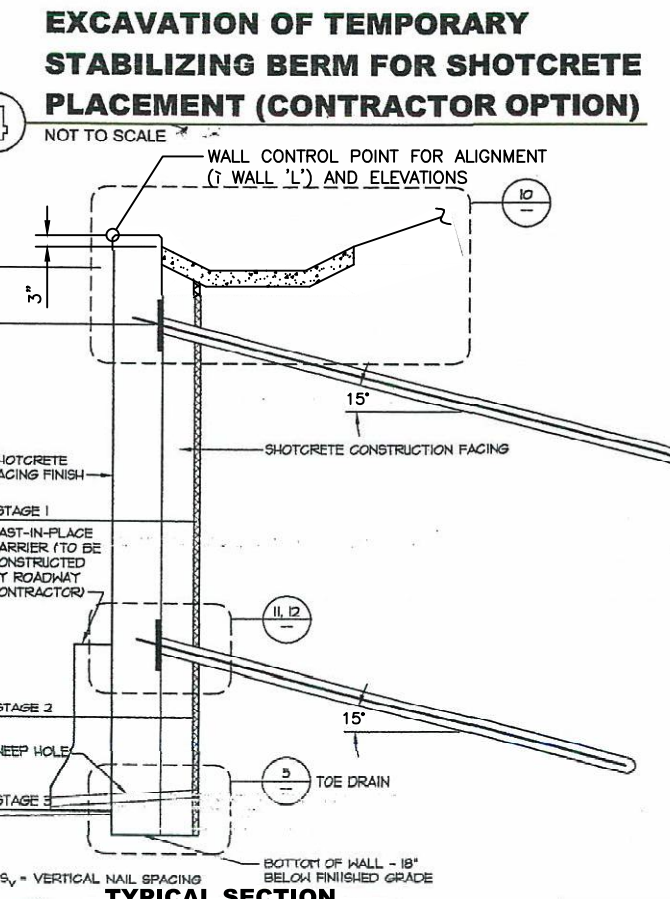
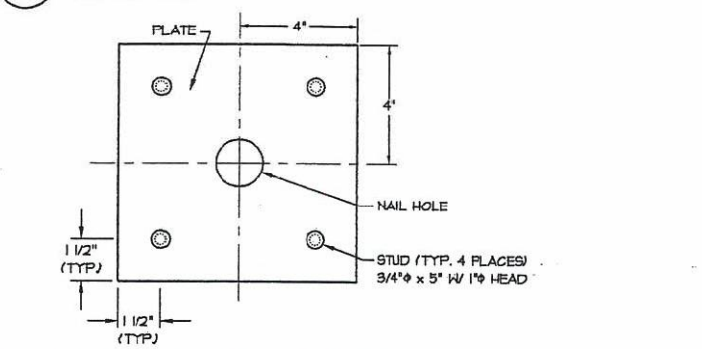
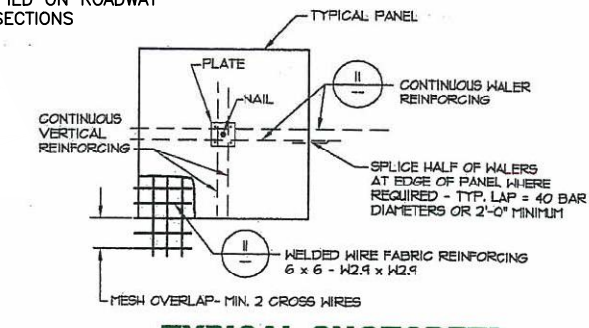
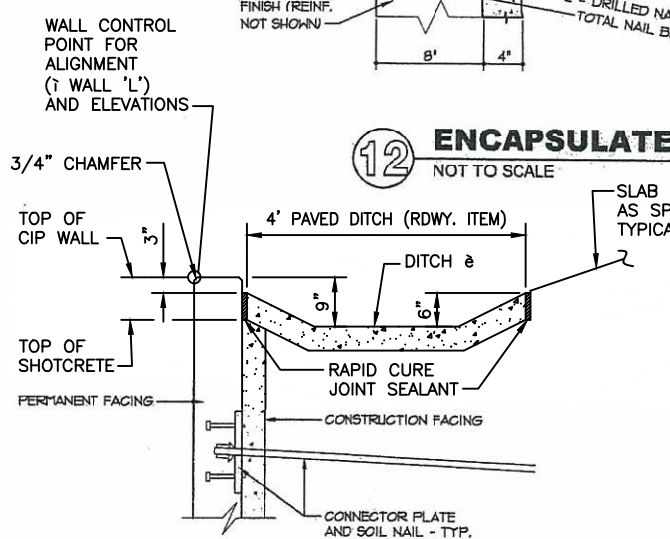
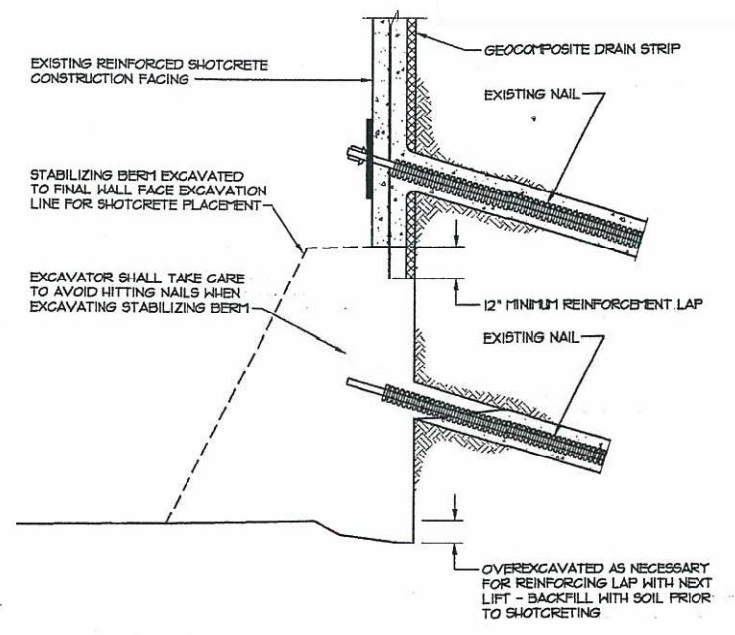
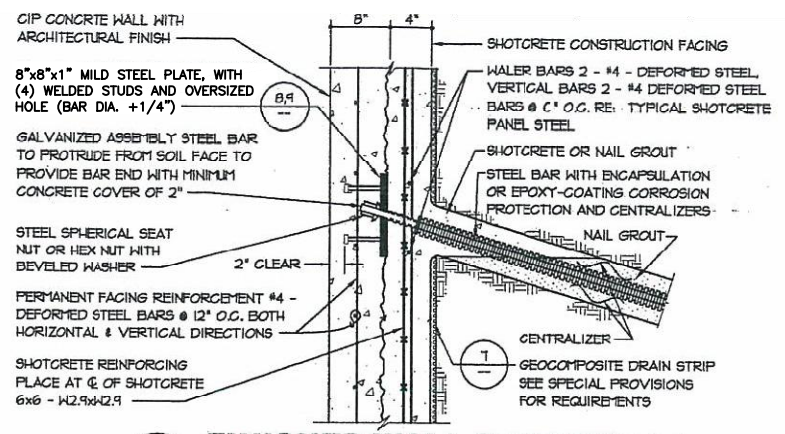
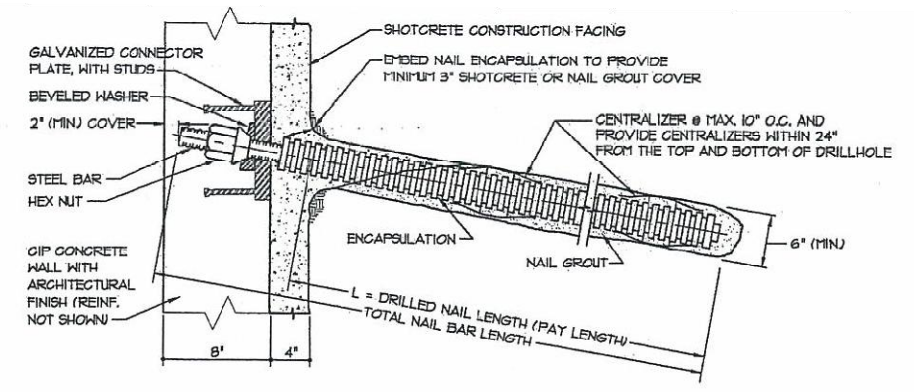

NOTES:
1. BARE BARS MAY BE USED FOR SACRIFICIAL TEST NAILS.
2. PROOF TEST DETAIL IS SAME EXCEPT LOAD CELL IS NOT REQUIRED.

PHASE 4 OKLAHOMA COUNTY

DESIGN	AIO	03/24
DRAWN	UH	03/24
CHECKED		
APPROVED		
SQUAD	GEOCAL	

SOIL NAIL RETAINING WALL '1'
DETAILS
(SHEET 1 OF 2)

STATE JOB NO. 09032(08) SHEET NO. RW26



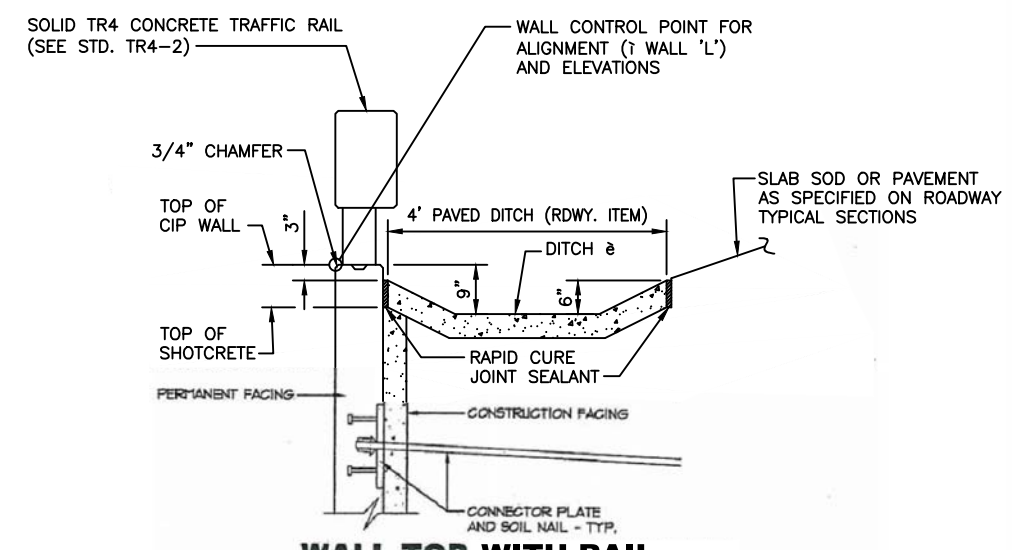

5 WALL TOP WITH RAIL CONCRETE GUTTER DETAIL
NOT TO SCALE

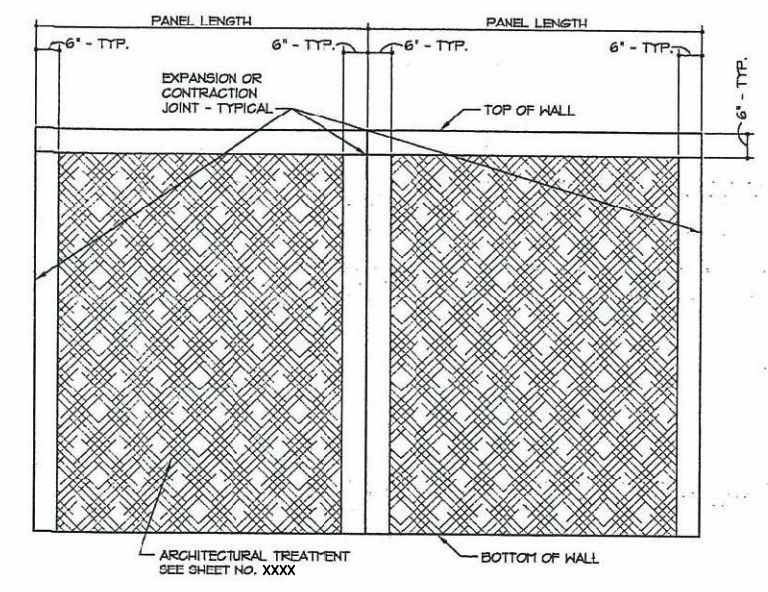

4 ELEVATION OF ARCHITECTURAL TREATMENT
NOT TO SCALE

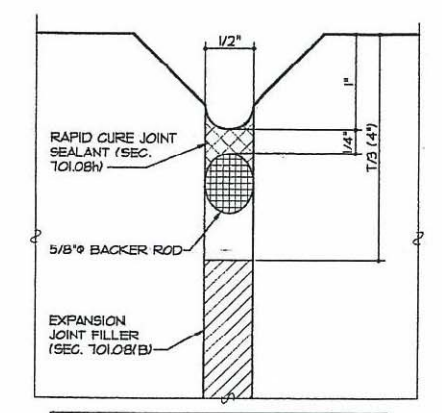

NOTE:
COST OF BACKER ROD, EXPANSION JOINT FILLER AND RAPID CURE SEALANT INCLUDED IN OTHER ITEMS OF WORK
FOR BACKER ROD AND JOINT SEALER GENERAL NOTES REFER TO STD. LECS-5.

3 DETAIL FOR RAPID CURE JOINT
NOT TO SCALE

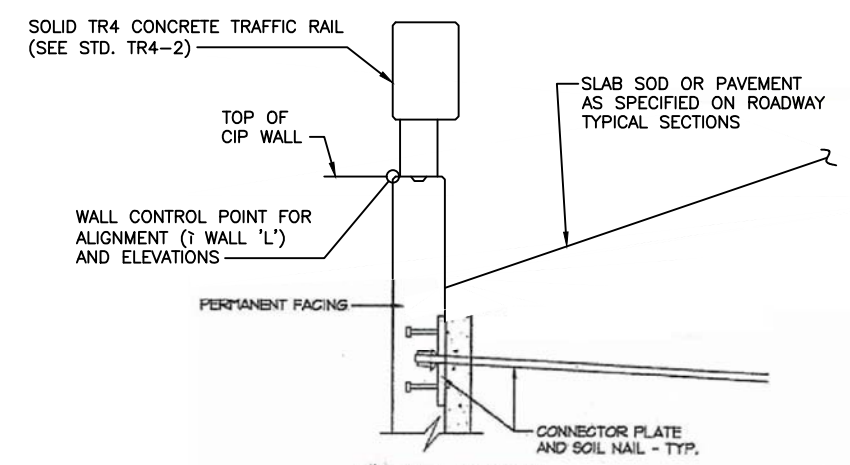

6 WALL TOP WITH RAIL DETAIL
NOT TO SCALE

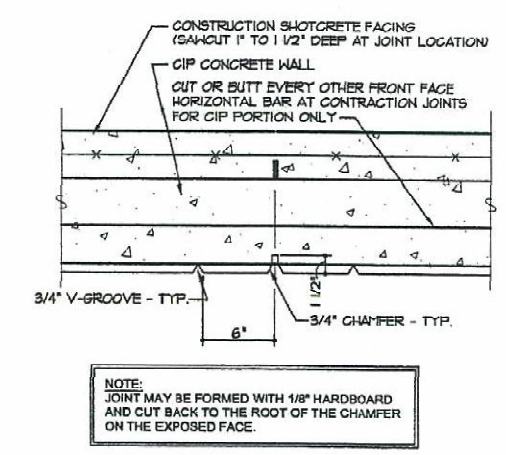

NOTE:
JOINT MAY BE FORMED WITH 1/8\"/>

2 TYPICAL SOIL NAIL WALL CONTRACTION JOINT
NOT TO SCALE

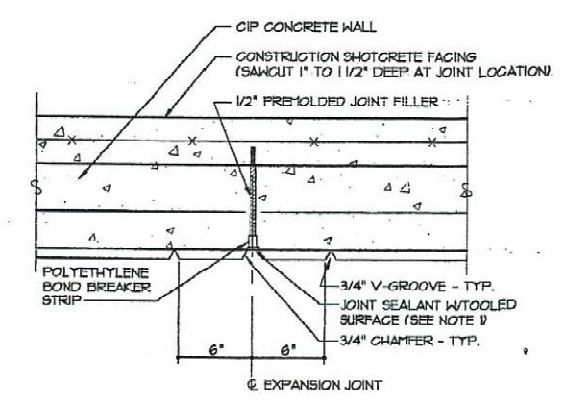

1 TYPICAL SOIL NAIL WALL EXPANSION JOINT
NOT TO SCALE

DESIGN	AIO	03/24
DRAWN	UH	0.3/24
CHECKED		
APPROVED		
SQUAD	GEOCAL	

SOIL NAIL RETAINING WALL '1'
DETAILS
(SHEET 2 OF 2)



SURVEY CONTROL DATA

1. HORIZONTAL CONTROL:

A. HORIZONTAL CONTROL FOR THIS SURVEY IS IN OKLAHOMA DEPARTMENT OF TRANSPORTATION PLANE COORDINATE SYSTEM. LAMBERT PROJECTION (NORTH ZONE). ALL COORDINATES SHOWN ARE ON OKLAHOMA DEPARTMENT OF TRANSPORTATION PLANE COORDINATE SYSTEM WHICH WERE DERIVED BY MULTIPLYING THE USC&GS OKLAHOMA PLANE COORDINATES BY THE COMBINED ADJUSTMENT FACTOR OF 1.00010. THE OKLAHOMA DEPARTMENT OF TRANSPORTATION COORDINATE SYSTEM PLANE IS 2350 FEET ABOVE THE OKLAHOMA USC&GS PLANE.

B. ACCURACY - 3RD ORDER OR BETTER

2. BEARINGS:

THE BEARINGS SHOWN HEREIN OR HEREON ARE GRID BEARINGS DERIVED FROM THE DEPARTMENT OF TRANSPORTATION PLANE COORDINATE SYSTEM AND ARE NOT ASTRONOMICAL. THE ANGLE OF VARIANCE BETWEEN GRID NORTH (GN) AND THE ASTRONOMICAL TRUE NORTH (TN) IS DEPICTED DIAGRAMMATICALLY.

3. VERTICAL CONTROL:

A. LEVEL DATUM IS MEAN SEA LEVEL (NGS), NGVD29.

B. ACCURACY - 3RD ORDER OR BETTER

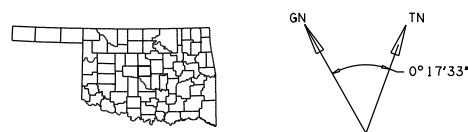

LOCATION MAP

CONVENTIONAL SIGNS

- INTERSTATE HIGHWAY
- U.S. HIGHWAY
- STATE HIGHWAY
- PROPOSED ROAD
- RAILROADS
- RANGE & TOWNSHIP LINES
- SECTION LINES
- QUARTER SECTION LINES
- FENCES
- GROUND LINE
- EXISTING ROADS
- BASE LINE
- GRADE LINES
- TELEPHONE & TELEGRAPH
- POWER LINES
- OIL WELLS
- BUILDINGS
- DRAINAGE STRUCTURES-IN-PLACE
- DRAINAGE STRUCTURES-NEW
- RIGHT-OF-WAY LINES-EXISTING
- RIGHT-OF-WAY LINES-NEW
- RIGHT-OF-WAY MARKERS-IN PLACE
- RIGHT-OF-WAY MARKERS-REMOVE & RESET
- RIGHT-OF-WAY MARKERS-NEW
- CONTROLLED ACCESS
- EXISTING SANITARY SEWERS
- EXISTING GAS LINES
- EXISTING WATER LINES
- EXISTING TELEPHONE CABLES UNDERGROUND

UTILITY CONTACT LIST	
AT&T	(405)275-8805
COX COMMUNICATIONS	(405)600-6269
LEVEL 3 COMMUNICATIONS	(405)471-3647
OG&E	(800)272-9741
ONG	(800)664-5463
DCP MIDSTREAM LLC/EDMOND	(405)341-1266
MCLEOD USA	(317)924-2592
QWEST COMMUNICATIONS	(800)899-7780
SOONER UTILITIES (WATER)	(405)721-4700
STEPHENS & JOHNSON OPERATING CO.:	(405)235-4146
TOWN OF VALLEY BROOK	(405)677-6948
WHITE OPERATING CO.	(405)239-6001
CITY OF OKLAHOMA CITY	(405)297-2278

STATE OF OKLAHOMA
DEPARTMENT OF TRANSPORTATION

SURVEY OF
STATE HIGHWAY

SWO 2923(1)
STATE JOB NO.09032(17)

OKLAHOMA COUNTY

I-35 & I-240 INTERCHANGE

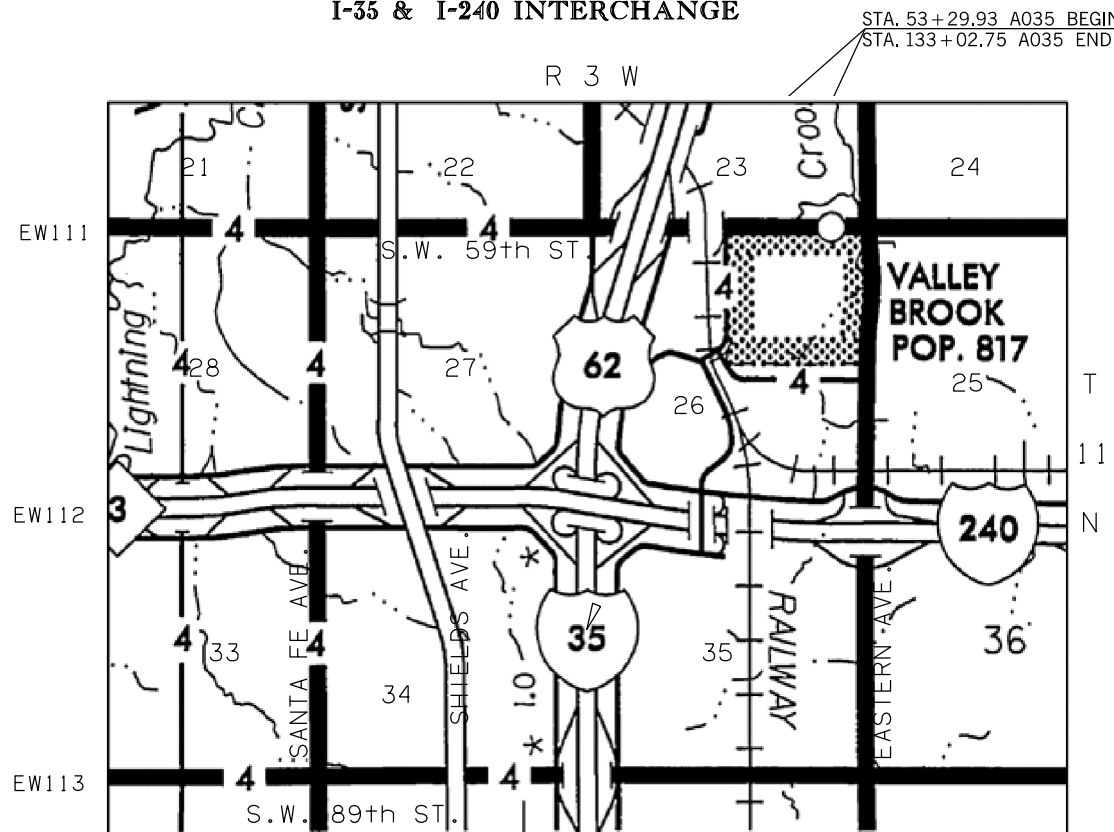

PROJECT LENGTH 10,590 Ft. 2.01 MI.

BEGINNING STATION : STA. 371+39.31 A034 BEGIN
ENDING STATION : STA. 500+14.57 A034 END

PROJECT LENGTH 7,973 Ft. 1.51 MI.

BEGINNING STATION : STA. 53+29.93 A035 BEGIN
ENDING STATION : STA. 133+02.75 A035 END

SURVEY SHEET INDEX

NO.	DESCRIPTION
01 OF 46	TITLE SHEET
02-05 OF 46	HISTORICAL LETTER
06-07 OF 46	BM & CHECKLEVELS LIST
08-11 OF 46	COORDINATE LIST
12-25 OF 46	ALIGNMENT REPORT
26-46 OF 46	SURVEY DATA SHEETS

STATE OF OKLAHOMA
DEPARTMENT OF TRANSPORTATION

SWO 2923(1) Job/Piece 09032(17) Engr. Contract No. 1060

LAND SURVEYOR'S CERTIFICATION

I hereby certify that all land and property subdivision distances, angles, corners and monumentation made or used in conjunction with this survey and depicted or recorded herein or hereon were recovered, established, or re-established in substantial conformity with:

- Applicable Instructions contained in the U.S. Government Bureau of Land Management publication "Manual of Surveying Instructions";
 - Its supplement, "Restoration of Lost or Obliterated Corners and Subdivision of Sections";
 - "Oklahoma Minimum Standards for the Practice of Land Surveying" as adopted by the State Board of Registration for Professional Engineers and Land Surveyors; and
 - Sound land surveying practices;
- Including a through search, study, analysis, and consideration of all existing records and field evidence.

I further certify that all survey monuments depicted exist and that all land survey work was done by me or under my direct supervision and that it is true, accurate, and correct to the best of my knowledge and belief.

Dated this 6th day of May 2016.

POE & ASSOCIATES, INC.
OKLAHOMA CITY, OKLAHOMA

Land Surveyor: *Justin Lee Talcott*
Signature

JUSTIN LEE TALCOTT
Printed Name

Oklahoma Registered Land Surveyor No. 1646

Certificate of Authorization No. 541

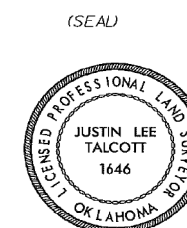

THIS SURVEY MEETS THE OKLAHOMA MINIMUM STANDARDS FOR THE PRACTICE OF LAND SURVEYING AS ADOPTED BY THE OKLAHOMA STATE BOARD OF REGISTRATION FOR PROFESSIONAL ENGINEERS AND LAND SURVEYORS, JUNE 11, 2001.

SPECIFICATIONS FOR SURVEYS FOR PRIMARY AND SECONDARY HIGHWAYS DATED FEB 6, 2006 GOVERN.

SDS 01 OF 46

Electronic File Transfer Disclaimer:

These Files, Drawings and/or Notes are provided for information only. The Oklahoma Department of Transportation (ODOT) and the Owner cannot be held responsible for the content or accuracy of these Files, Drawings and/or Notes due to conversions, software translations, or any other manipulation of said Files, Drawings and/or Notes. ODOT expressly disclaims any responsibility arising from any use of these Files, Drawings and/or Notes. To the full extent permitted by applicable law, the recipient of these Files, Drawings and/or Notes hereby agrees to defend, indemnify, and hold harmless ODOT and the Owner from and against any and all claims, suits, actions, damages, loss, liability or costs of every nature or description (including reasonable attorney's fees) arising from, or in any way attributable to or connected with any of these Files, Drawings and/or Notes.



PLS		POE & ASSOCIATES, OKLAHOMA CITY, OK SURVEY DIVISION		
DRAWN		SURVEY DATA SHEET		
CHECKED				
APPROVED				
CREW				
POE		SWO 2923(1)	PROJECT NO. 09032(17)	SHEET NO. 5001

SWO 2923(1), I-35/I-240 Oklahoma County
Historical Letter & Written Report
Page 2 of 8

Oklahoma Department of Transportation
Survey Division (405)521-2621 Fax (405)522-0364

Date: September 1, 2015

To: Mr. William Leroy Tackett, Chief of Surveys
From: Justin Lee Talcott, Professional Land Surveyor
Subject: SWO 2923(1), J/P 09032(17) – Oklahoma County
I-35/I-240 Interchange

Historical Letter & Written Report

1. GENERAL:

Survey Began: November 21, 2006
Survey Completed: August 1, 2015

Personnel on this Survey:

Justin Lee Talcott Professional Land Surveyor, OK #1646
Jack B. Weaver (Retired) Professional Land Surveyor, OK #955
Robert M. Perez Assistant Surveyor
Mickey Parsons Assistant Surveyor
Andrew Moss Assistant Surveyor
Chad Baker Assistant Surveyor
Tremetria Williams CAD Technician

2. PURPOSE:

The purpose of this survey was to furnish sufficient data to develop plans to reconstruct the I-35/I-240 Interchange in Oklahoma City, Oklahoma.

3. SURVEY LIMITS:

I-35: Along I-35 from S.E. 82nd Street, North to S.E. 59th Street (approximate centerline length = 1.50 miles).

I-240: Along I-240 from Santa Fe Avenue, East to Eastern Avenue (approximate centerline length = 2.00 miles).

1. ALIGNMENT:

I-35 MAINLINE (A035): The Centerline of Survey for this mainline is along and identical to the centerline of present I-35 as established and shown on FAP I-381(4) plans.

SE 82ND STREET CONNECTION (A032): The Centerline of Survey for this connection is along and identical to the centerline of present SE 82nd Street as established and shown on FAP IR-35-3(074)121 plans being 8.7 feet south of the quarter section line of Section 34, T11N-R3WIM.

SE 66TH STREET CONNECTION (A031): The Centerline of Survey for this connection is along the quarter section lines of Sections 26 & 27, T11N-R3WIM and identical to the centerline of present SE 66th Street as established and shown on FAP IR-35-3(074)121 plans.

SE 59TH STREET CONNECTION (A030): The Centerline of Survey for this connection is along the north line of Section 26, T11N-R3WIM and identical to the centerline of present SE 59th Street as established and shown on FAP IR-35-3(110)123 plans.

I-240 MAINLINE (A036): The Centerline of Survey for this mainline is along and identical to the centerline of present I-240 as established and shown on FAP IR-240-1(323) west of the interchange and FAP IR-240-4(86)157 east of the interchange. Utilizing FAP F-369(094) for the Shields Blvd. crossing and FAP I-381(4) for the Crossroads interchange. The north I-240 service road alignments at approximately station 438+00.00 do not graphically match, but are calculated from the same I-240 centerline with different offsets from different reference plans. The service road going west from this point using reference plan FAP I-381(4) matches the existing back of curb and the service road going east from this point using reference plan FAP I-240(86)157 and matches the existing centerline.

SANTA FE AVENUE CONNECTION (A011): The Centerline of Survey for this connection is along the west line of Sections 27 & 34, T11N-R3WIM and identical to the centerline of present Santa Fe Avenue as established and shown on FAP IR-240-1(323) plans.

SHIELDS BOULEVARD CONNECTION (A012): The Centerline of Survey for this connection is along and identical to the centerline of present Shields Boulevard as established and shown on FAP IR-240-1(323) and FAP F-369(094) plans.

BNSF RAILROAD MAINLINE (A015): The Centerline of Survey for this mainline is along and identical to the centerline of present BNSF Railroad as established and shown on FAP I-240-4(86)157 plans.

EASTERN AVENUE CONNECTION (A014): The Centerline of Survey for this connection is along the east line of Sections 26 & 35, T11N-R3WIM and identical to the centerline of present Eastern Avenue as established and shown on FAP I-240-4(86)157 and SWO 5030(01) plans.

PLS			POE & ASSOCIATES, OKLAHOMA CITY, OK	
DRAWN			SURVEY DIVISION	
CHECKED			SURVEY DATA SHEET	
APPROVED				
CREW	POE	SWO 2923(1)	PROJECT NO. 09032(08)	SHEET NO. 5002

SWO 2923(1), I-35/I-240 Oklahoma County
Historical Letter & Written Report
Page 3 of 8

1. STATIONING:

I-35 MAINLINE: Stationing for this survey is identical to present I-35 and taken from FAP I-381(4) plans. Beginning at SE 82nd Street, the present station 53+29.93 is equal to FAP I-381(4) station 53+36.10, present station 79+77.15 is equal to FAP I-381(4) station 79+75.83 at the centerline of crossroads interchange and present PT station 130+74.84 is equal to FAP I-381(4) station 130+70.85 and ending with present station 133+02.75 being equal to FAP I-IR-33-3(110)123 station 133+02.69.

SE 82ND STREET CONNECTION: Stationing for this survey is identical to present SE 82nd Street taken from FAP I-IR-35-3(074)121 plans with a centerline of I-35 station of 99+02.99 and extending west 500' to station 94+02.99 and east 500' to station 104+02.99.

SE 66TH STREET CONNECTION: Stationing for this survey is identical to present SE 66th Street taken from FAP I-IR-35-3(074)121 plans with a centerline of I-35 station of 209+02.99 and extending west 500' along the section line to station 204+02.99 and east 500' (passing the NW corner of Section 26 at 97.02' for a station of 210+00.01) along the section line to station 214+02.99.

SE 59TH STREET CONNECTION: Stationing for this survey is identical to present SE 59th Street taken from FAP IR-35-3(110)123 plans with a centerline of I-35 station of 100+00.00 and extending west along the section line 500' to station 95+00.00 passing the Northwest corner of Section 26 present station 97+60.928 equal to said plans 97+60.88 and east from the centerline along the section line for 500' to station 105+00.00.

I-240 MAINLINE: Stationing for this survey is identical to present I-240 as established and shown on FAP IR-240-1(323), FAP I-381(4) and FAP I-240-4(86)157plans. Beginning at the centerline of I-240 and Santa Fe with a station of 376+33.43 being equal to station 376+33.72 FAP IR-240-1(323), running through the station at the centerline of Shields Blvd 393+43.79 being equal to same station 393+43.79 FAP IR-240-1(323), through the station equation at 415+08.92 Back/415+00.00 Ahead equal to same equation from FAP IR-240-1(323), through the centerline of I-35 station 428+14.28 being equal to station 428+14.27 FAP I-381(4) and ending at the centerline of Eastern Avenue station 482+14.52 being equal to 482+01.92 FAP I-240-4(86)157 plans.

SANTA FE CONNECTION: Stationing for this survey is identical to present Santa Fe as established and shown on FAP IR-240-1(323) plans with a centerline of I-240 present station of 100+96.72 being equal to station 100+97.00 on same plans and extending north 500' along the section line to station 105+96.72 and south along the section line (through the NW corner of Section 34 at station 100+00.00) for 500' to station 95+96.72.

SHIELDS BOULEVARD CONNECTION: Stationing for this survey is identical to present Shields Boulevard as established and shown on FAP IR-240-1(323) and FAP F-369(094) plans with a centerline of I-240 present station of 147+61.38 being equal to same station 147+61.38 on same plans and extending northwest 500' to station 152+61.38 and southeast for 500' to station 142+61.38.

SWO 2923(1), I-35/I-240 Oklahoma County
Historical Letter & Written Report
Page 4 of 8

BNSF RAILROAD MAINLINE: Stationing for this survey is identical to the present BNSF railroad as shown on FAP I-240-4(86)157 plans. Present main line station with centerline of I-240 is 20564+76.90 which began at the PC station 20566+70.42 south of I-240 and extended north through the existing curve to the Plaza Mayor Boulevard crossing.

EASTERN AVENUE CONNECTION: Stationing for this survey is identical to present Eastern Avenue as established and shown on FAP I-240-4(86)157 plans with a centerline of I-240 station of 25+10.87 and extended north along the section line (through the SE corner of Section 26 at station 26+34.64) for 500' to station 30+10.87 and extended south along the section line for 500' to station 20+10.87.

1. HORIZONTAL CONTROL:

Horizontal control for this survey is the Oklahoma Department of Transportation Plane Coordinate System, Lambert Projection (North zone). All coordinates shown are Oklahoma Department of Transportation Plane coordinates which were derived by multiplying the USC&GS Oklahoma Plane coordinates by the combined adjustment factor of 1.00010. The Oklahoma Department of Transportation Coordinate System Plane is 2350 feet above the Oklahoma USC&GS Plane. We established 5 control points (O-55-1837, O-55-1838, O-55-1839, O-55-1840, O-55-1841) within the survey limits.

2. VERTICAL CONTROL:

Vertical Control for this survey is NGVD29 datum matching the Oklahoma Department of Transportation Plane Coordinate System establishing 49 benchmarks along our project.

3. MEASUREMENT UNITS:

The distances, coordinates, and elevations shown on this survey are in US Survey Feet. All angles and grid bearings shown are in degrees, minutes, and seconds derived from the Oklahoma Department of Transportation Plane Coordinate System and are not astronomical.

4. TOPOGRAPHY/DIGITAL TERRAIN MODEL:

Topography and surface features were collected by aerial photogrammetry, performed and processed by ADS, our sub-consultant for this project. Traditional survey methods (RTK and Total Station) were used alongside the aerial photogrammetry to supplement areas needed.

5. LAND TIES:

All land corners that were required on this survey have been researched and verified in the field as existing, set this survey, or calculated. All corners were easily accessible and found within road right of way, a request for certified corners revealed at least one (1) existing monument at every corner.

PLS			POE & ASSOCIATES, OKLAHOMA CITY, OK	
DRAWN			SURVEY DIVISION	
CHECKED			SURVEY DATA SHEET	
APPROVED				
CREW	POE	SWO <u>2923(1)</u>		

SWO 2923(1), I-35/I-240 Oklahoma County
Historical Letter & Written Report
Page 5 of 8

Southwest Corner Section 27, T11N-R3WIM

I found this corner in place, being a 1/2" iron pin, ODOT monument number O-55-1367 and is in agreement with previous certified corner records. This monument is located just north of the intersection of South Santa Fe and the south service road of Interstate 240.

West Quarter Corner of Section 27, T11N-R3WIM

I found this corner in place, being a P.K. nail, ODOT monument number O-55-1368, and is in agreement with previous certified corner records. This monument is located at the intersection of South Santa Fe and SE 66th Street.

Northwest Corner Section 27, T11N-R3WIM

I found this corner in place, being a 3/8" iron pin with a new ODOT monument number O-55-1850 and is in agreement with previous certified corner records. This monument is located in the intersection of South Santa Fe and SE 59th Street.

North Quarter Corner Section 27, T11N-R3WIM

I found this corner in place, being a 1/2" iron pin with a new ODOT monument number O-55-1851 and is in agreement with previous certified corner records. This monument is located in the intersection of South Byers Avenue and SE 59th Street.

Northeast Corner Section 27, T11N-R3WIM

I found this corner in place, being a chiseled "X" in the concrete intersection of the I-35 Service Road and SE 59th Street. This monument has an ODOT monument number of O-55-97 and is in agreement with previous certified corner records.

East Quarter Corner Section 27, T11N-R3WIM

I found this corner in place, being a chiseled "X" in concrete west of the intersection of I-35 Service Road and SE 66th Street. This monument has an ODOT monument number of O-55-99 and is in agreement with previous certified corner records.

Southeast Corner Section 27, T11N-R3WIM

I found this corner in place, being a 1/2" iron pin, ODOT monument number O-55-634 and is in agreement with previous certified corner records. We found this monument located on the east edge of the northbound I-35 driving lane approximately a foot west of the bridge support wall.

South Quarter Corner Section 27, T11N-R3WIM

I found this corner in place, being a P.K. nail, ODOT monument number O-55-1313 and is in agreement with previous certified corner records. This monument is located on the north edge of the I-240 Service Road and just west of the east bound I-240 on ramp.

Center Corner Section 27, T11N-R3WIM

I found this corner in place, being a P.K. nail, ODOT monument number O-55-1314 and is in agreement with previous certified corner records. I also found a P.K. nail N 85°12'30"E a distance of 0.66', this P.K. nail was not accepted. Monument is located in the intersection of South Byers Avenue and SE 66th Street.

SWO 2923(1), I-35/I-240 Oklahoma County
Historical Letter & Written Report
Page 6 of 8

North Quarter Corner Section 26, T11N-R3WIM

I found this corner in place, being a P.K. nail, ODOT monument number O-55-98 and is in agreement with previous certified corner records. This monument is located NE of the intersection of SE 59th Street and Crossroads Blvd.

Northeast Corner Section 26, T11N-R3WIM

I found this corner in place, being a P.K. nail, ODOT monument number O-55-1766 and is in agreement with previous certified corner records. This monument is located approximately 50 feet west of the intersection of SE 59th Street and South Eastern Avenue.

East Quarter Corner Section 26, T11N-R3WIM

I found this corner in place, being a chiseled "X" in concrete in the approximate centerline of South Eastern Avenue and agrees with previous certified corner records. This monument has as ODOT number of O-55-1767.

Southeast Corner Section 26, T11N-R3WIM

I found this corner in place, being a 1/2" iron pin, ODOT monument number O-55-628 and is in agreement with previous certified corner records. I also found a 3/8" iron pin approximately 2' south that doesn't match references or certified corner records. This monument is located in the median of South Eastern Avenue and approximately 73' north of the north pier under I-240.

South Quarter Corner Section 26, T11N-R3WIM

I found this corner in place, being an ODOT brass monument with a number of O-55-627 and is in agreement with previous certified corner records. This monument is located south of the I-240 Service Road and east of the west bound I-240 on ramp.

Center Corner Section 26, T11N-R3WIM

I found this corner in place, being a 1/2" iron pin, ODOT monument number O-55-1315 and is in agreement with previous certified corner records. Monument is located under a chain link fence, northeast of SE 66th Street and northwest of a driveway.

East Quarter Corner Section 35, T11N-R3WIM

I found this corner in place, being a P.K. nail, ODOT monument number O-55-629 and is in agreement with previous certified corner records. This monument is located in the approximate centerline of South Eastern Avenue.

Southeast Corner Section 35, T11N-R3WIM

I found this corner in place, being a mag nail with the head broke off, ODOT monument number O-55-630 and is in agreement with previous certified corner records. This monument is in the approximate center of the concrete intersection of South Eastern Avenue and SE 89th Street.

South Quarter Corner Section 35, T11N-R3WIM

I found this corner in place, being an ODOT brass cap with a monument number of O-55-631 and is in agreement with previous certified corner records. This monument is east of the centerline of the intersection of SE 89th Street and Pole Road.

PLS			POE & ASSOCIATES, OKLAHOMA CITY, OK	
DRAWN			SURVEY DIVISION	
CHECKED			SURVEY DATA SHEET	
APPROVED				
CREW	POE	SWO 2923(1)		

SWO 2923(1), I-35/I-240 Oklahoma County
Historical Letter & Written Report
Page 7 of 8

Southwest Corner Section 35, T11N-R3WIM

I found this corner in place, being a chiseled "X" west of the concrete intersection of SE 89th Street and the I-35 Service Road. This monument has an ODOT number of O-55-632 and is in agreement with previous certified corner records.

West Quarter Corner Section 35, T11N-R3WIM

I found this corner in place, being a chiseled "X" west of the concrete intersection of SE 82nd Street and the I-35 Service Road, north of the centerline of SE 82nd Street. This monument has an ODOT number of O-55-633 and is in agreement with previous certified corner records.

Center Corner Section 35, T11N-R3WIM

I found this corner in place, being a 3/8" iron pin, ODOT monument number O-55-635 and is in agreement with previous certified corner records. This monument is located approximately 40' east of Pole Road and is in the bottom of a drainage channel with a t-post set nearby.

South Quarter Corner Section 34, T11N-R3WIM

I found this corner in place, being a mag nail with a Durham washer, ODOT monument number O-55-1306 and is in agreement with previous certified corner records. This monument is in the approximate center of the intersection of SE 89th Street and South Shields Blvd.

Southwest Corner Section 34, T11N-R3WIM

I found this corner in place, being a mag nail with a Hale & Buckley washer, ODOT monument number O-55-1849 and is in agreement with previous certified corner records. This monument is in the approximate center of the intersection of SE 89th Street and South Santa Fe Avenue.

West Quarter Corner Section 34, T11N-R3WIM

I found this corner in place, being a 3/8" iron pin, ODOT monument number O-55-1366 and is in agreement with previous certified corner records. This monument is in the approximate centerline of South Santa Fe Avenue.

Center Corner Section 34, T11N-R3WIM

I found this corner in place, being a 1/2" iron pin, ODOT monument number O-55-1312 and is in agreement with previous certified corner records. This monument is approximately 6' east of the curb of the northbound Shields Blvd and approximately 50' north of the centerline of a driveway.

1. ENVIRONMENTAL CONCERNS:

There are 2 environmental concerns documented and recorded within this survey. At the southwest corner of I-240 and Shields Blvd, approximately Sta. 390+83.00 to 393+94.00 145' Rt. to 397' Rt., Mosley's Texaco (which is now Discount Tire), 7501 S. Shields Blvd, OCC FAC #5508224 Case #064-1702, and at the southeast corner of I-240 and Shields Blvd, approximately Sta. 394+86.00 to 396+25.00 154' Rt. to 335' Rt., Shields Conoco (which is now Enterprise Rent a Car), 7500 S. Shields Blvd, OCC FAC #5508554 Case #064-0831.

SWO 2923(1), I-35/I-240 Oklahoma County
Historical Letter & Written Report
Page 8 of 8

1. RIGHT OF WAY:

Right of way within the survey was taken from deeds and plats acquired from the Oklahoma County courthouse, right of way division at Oklahoma Department of Transportation and supplemented with the following plans, F-369(094), FAP I-240-4(86)157, FAP I-IMY-35-(221)(247)120, FAP I-IR-35-3(074)121, FAP I-IR-35-3(108)119, FAP I-IR-35-3(110)23, FAP U-386(1), IR-240-1(323)000, IR-240-1(324)000, IR-240-1(325)000. The railroad right of way along the north and east of the current BNSF Railway was taken from the Crossroads Industrial Park subdivision plat. The south and east side of said railway was taken from a description of an unplatted portion at the County Assessor's office and confirmed with a Quit Claim deed filed in book 13046, page 1571 and matches the physical evidence of the existing rails. The portion of the right-of-way between these north and south descriptions and the "triangle" portion are described at the Oklahoma County courthouse in book 4505, page 1908.

2. UTILITIES:

All utility companies servicing the project extents were contacted, after first contacting OKIE during the course of this survey. Survey crew personnel met with a locator and/or discussed per phone conversation the location of existing utilities during this survey. Utilities shown were collected and/or verified from field data, atlas maps and existing plans. Obvious gaps or omitted areas were either not located by participating utility companies or could not be verified in the field. There are 2 ODOT fiber lines of unknown pair size that cross I-35 at approximate stations 78+39.00 and 84+34.00. There is also a Century Link (formerly Qwest) fiber line of unknown pairs crossing I-240 at approximately station 458+99.00 and a Level 3 Communications Tug line of unknown pairs crossing I-240 at approximately station 460+99.31, several attempts were made to contact these 2 companies with no results.

3. EQUIPMENT USED:

Topcon HIPER V GPS receivers, Topcon GR3 GPS receivers, Topcon PS-103 Robotic Total Station Sokkia SET 330R Total Station and Sokkia B20 automatic level.

4. DATA SUBMITTED:

1. SWO2923_1_V1.dgn
2. SWO2923_1_V1_TOPO.dgn
3. SWO2923_1_V1_TRI.dgn
4. SWO2923_1_V1_SFF.dgn
5. SWO2923_1_V1_DRA.dgn
6. ODOT form SD-1, Transmittal Letter.
7. ODOT form SD-41, Surveyor's Certification.
8. ODOT form SD-11 for 5 monuments
9. ODOT form SD-7 Utility form
10. PDF certified corner records.
11. Cogo Data (Coordinate List with Alignments)
12. Historical Letter.
13. BM's and Check Levels

Justin Lee Talcott
Professional Land Surveyor

PLS			POE & ASSOCIATES, OKLAHOMA CITY, OK	
DRAWN			SURVEY DIVISION	
CHECKED			SURVEY DATA SHEET	
APPROVED				
CREW	POE	SWO 2923(1)	PROJECT NO. 09032(08)	SHEET NO. 5005

B.M.36	1290.6	1290.59		-0.01	-6.59	-6.6		-6.595	1290.595	1290.63		Square on south curb return at SE 79th, NW of Ice Rink CL I-35 STA. 65+79.07 234.04' RT.
B.M.37	1292.93	1292.92		-0.01	2.335	2.325		2.33	1292.925	1292.96		X on north headwall at SW corner of OG&E yard CL I-35 STA. 67+15.69 865.26' RT.
B.M.38	1296.01	1296		-0.01	3.085	3.075		3.08	1296.005	1296.05		#6 rebar, 6' west of OG&E fence, 3rd light pole from north CL I-240 STA. 437+85.95 693.64' RT.
B.M.39	1300.34	1300.33		-0.01	4.335	4.325		4.33	1300.335	1300.38		X on west curb, east of lightpole at OG&E main parking lot CL I-240 STA. 446+25.79 262.04' RT.
B.M.40	1295.87	1295.85		-0.02	-4.465	-4.485		-4.475	1295.86	1295.9		Square on concrete footing at NNE fence corner of OG&E yard CL I-240 STA. 450+98.17 326.25' RT.
B.M.41	1280.47	1280.45		-0.02	-15.39	-15.41		-15.4	1280.46	1280.5		Square on concrete footing at NE fence corner of OG&E yard CL I-240 STA. 455+77.93 606.19' RT.
B.M.42	1270.94	1270.94		0	-9.52	-9.52		-9.52	1270.94	1270.98		#6 rebar at NW corner of fence and Budweiser property CL I-240 STA. 461+03.91 196.39' RT.
B.M.43	1259.74	1259.73		-0.01	-11.2	-11.21		-11.205	1259.735	1259.78		#6 rebar CL I-240 STA. 472+71.40 197.10' RT.
B.M.44	1278.31	1278.29		-0.02	18.575	18.555		18.565	1278.3	1278.35		#6 rebar CL I-240 STA. 478+53.14 372.48' RT.
B.M.45	1286.2	1286.18		-0.02	7.9	7.88		7.89	1286.19	1286.24		X on headwall, west of Eastern CL I-240 STA. 481+88.67 511.12 RT.

B.M.46	1297.7	1297.7		0	11.51	11.51		11.51	1297.7	1297.75		#5 rebar at Diamond Ballroom CL I-240 STA. 480+17.65 1980.08' RT.
DIAMOND O-55-1839												
B.M.45	1286.19	1286.2		0.01	-11.51	-11.5		-11.505	1286.195	1286.25		X on headwall, west of Eastern CL I-240 STA. 481+88.67 511.12 RT.
B.M.48	1268.63	1268.62		-0.01	-17.565	-17.575		-17.57	1268.625	1268.68		X on sign base, west of Eastern CL I-240 STA. 479+00.40 312.21' LT.
B.M.49	1259.74	1259.73		-0.01	-8.885	-8.895		-8.89	1259.735	1259.79		Square on top curb, SE parking lot of "Heartwood" CL I-240 STA. 470+91.46 178.33' LT.
B.M.50	1269.68	1269.67		-0.01	9.945	9.935		9.94	1269.675	1269.73		Square on manhole CL I-240 STA. 464+22.30 147.47 LT.
B.M.51	1290	1290.01		0.01	20.325	20.335		20.33	1290.005	1290.06		X on curb PI E & N CL I-240 STA. 453+21.36 317.36' LT.
B.M.52	1308.74	1308.77		0.03	18.735	18.765		18.75	1308.755	1308.81		X on curb, S. of lightpole E. of "MALL" CL I-240 STA. 445+65.52 308.74' LT.
B.M.53	1308.4	1308.42		0.02	-0.355	-0.335		-0.345	1308.41	1308.47		#5 rebar with cap CL I-240 STA. 444+54.12 286.71' LT.
MALL O-55-1841												
B.M.54	1300	1300.02		0.02	-8.41	-8.39		-8.4	1300.01	1300.07		X on curb at east parking lot of Texas Roadhouse CL I-240 STA. 439+31.47 209.30' LT.

B.M.56	1288.8	1288.82		0.02	-11.21	-11.19		-11.2	1288.81	1288.87		X on curb, south of Hibdon Tires Plus CL I-240 STA. 433+68.62 541.94' LT.
B.M.57	1286.03	1286.03		0	-2.78	-2.78		-2.78	1286.03	1286.09		Square on top of headwall CL I-35 STA. 84+07.16 388.69' RT.
B.M.58	1289.4	1289.39		-0.01	3.37	3.36		3.365	1289.395	1289.46		X on curb of NW parking lot at Best Buy CL I-35 STA. 88+25.03 171.55' RT.
B.M.59	1285.56	1285.56		0	-3.835	-3.835		-3.835	1285.56	1285.62		Square on top of headwall CL I-35 STA. 94+25.50 13147' RT.
B.M.60	1295.68	1295.69		0.01	10.12	10.13		10.125	1295.685	1295.75		X on curb of west parking lot at Ramada Inn CL I-35 STA. 101+09.27 176.35' RT.
FIRESTONE	1300.22	1300.22		0	4.535	4.535		4.535	1300.22	1300.28	1300.28	Square on sidewalk at Firestone CL I-35 STA. 107+92.56 204.35' RT.

90% PLAN SUBMITTAL 3/4/2024

Table with columns: COORDINATES POINT NAME, NORTHING, EASTING, DESCRIPTION. Rows 504-950.

Table with columns: COORDINATES POINT NAME, NORTHING, EASTING, DESCRIPTION. Rows 5000-5141.

Table with columns: COORDINATES POINT NAME, NORTHING, EASTING, DESCRIPTION. Rows 5142-5244.

Table with columns: COORDINATES POINT NAME, NORTHING, EASTING, DESCRIPTION. Rows 5245-5330.

Form with fields: PLS, DRAWN, CHECKED, APPROVED, CREW, POE, SWO, PROJECT NO., SHEET NO., OKLAHOMA COUNTY.

90% PLAN
SUBMITTAL
3/4/2024

COORDINATES

Table with columns: POINT NAME, NORTHING, EASTING, DESCRIPTION. Rows 5331-5432.

COORDINATES

Table with columns: POINT NAME, NORTHING, EASTING, DESCRIPTION. Rows 5433-6334.

COORDINATES

Table with columns: POINT NAME, NORTHING, EASTING, DESCRIPTION. Rows 6335-7436.

COORDINATES

Table with columns: POINT NAME, NORTHING, EASTING, DESCRIPTION. Rows 7437-8538.

Form with fields: PLS, DRAWN, CHECKED, APPROVED, CREW, POE, SWO, PROJECT NO., SHEET NO., OKLAHOMA COUNTY.

90% PLAN
SUBMITTAL
EASTING 3/4/2024

Project Name: EC-1060*Crossroads
Description: survey alg for Crossroads Interchange
Horizontal Alignment Name: A008 *CONTINUED
Description: RAMP SE of I-240
Style: Default

Table with columns: STATION, NORTHING, EASTING. Contains data for Linear and Circular elements with stationing and coordinates.

Table with columns: STATION, NORTHING, EASTING. Contains data for Circular element with stationing and curve details.

Table with columns: STATION, NORTHING, EASTING. Contains data for Linear element with stationing and coordinates.

Table with columns: STATION, NORTHING, EASTING. Contains data for Linear element with stationing and coordinates.

Table with columns: STATION, NORTHING, EASTING. Contains data for Circular element with stationing and curve details.

Project Name: EC-1060*Crossroads
Description: survey alg for Crossroads Interchange
Horizontal Alignment Name: A009 *CONTINUED
Description: N of I-240
Style: Default

Table with columns: STATION, NORTHING, EASTING. Contains data for Linear element with stationing and coordinates.

Project Name: EC-1060*Crossroads
Description: survey alg for Crossroads Interchange
Horizontal Alignment Name: A009 *CONTINUED
Description: N of I-240
Style: Default

Table with columns: STATION, NORTHING, EASTING. Contains data for Circular element with stationing and curve details.

Table with columns: STATION, NORTHING, EASTING. Contains data for Linear element with stationing and coordinates.

Table with columns: STATION, NORTHING, EASTING. Contains data for Circular element with stationing and curve details.

Table with columns: STATION, NORTHING, EASTING. Contains data for Linear element with stationing and coordinates.

Table with columns: STATION, NORTHING, EASTING. Contains data for Circular element with stationing and curve details.

Table with columns: STATION, NORTHING, EASTING. Contains data for Linear element with stationing and coordinates.

Table with columns: STATION, NORTHING, EASTING. Contains data for Linear element with stationing and coordinates.

Project Name: EC-1060*Crossroads
Description: survey alg for Crossroads Interchange
Horizontal Alignment Name: A009 *CONTINUED
Description: N of I-240
Style: Default

Table with columns: STATION, NORTHING, EASTING. Contains data for Circular element with stationing and curve details.

Table with columns: STATION, NORTHING, EASTING. Contains data for Circular element with stationing and curve details.

Table with columns: STATION, NORTHING, EASTING. Contains data for Circular element with stationing and curve details.

Table with columns: STATION, NORTHING, EASTING. Contains data for Circular element with stationing and curve details.

Table with columns: PLS, DRAWN, CHECKED, APPROVED, CREW. Includes project details: PROJECT NO. 090321081, SHEET NO. S020.

90% PLAN
SUBMITTAL

3/4/2024

Project Name: EC-1060*Crossroads
Description: survey alg for Crossroads Interchange
Horizontal Alignment Name: A010
Description: S of I-240
Style: Default

Table with columns: STATION, NORTHING, EASTING. Contains data for Element: Linear and Element: Circular with various stationing and bearing information.

Table with columns: STATION, NORTHING, EASTING. Contains data for Element: Linear with stationing and bearing information.

Table with columns: STATION, NORTHING, EASTING. Contains data for Element: Circular with stationing, bearing, and curvature information.

Table with columns: STATION, NORTHING, EASTING. Contains data for Element: Circular with stationing, bearing, and curvature information.

Table with columns: STATION, NORTHING, EASTING. Contains data for Element: Linear with stationing and bearing information.

Table with columns: STATION, NORTHING, EASTING. Contains data for Element: Circular with stationing, bearing, and curvature information.

Project Name: EC-1060*Crossroads
Description: survey alg for Crossroads Interchange
Horizontal Alignment Name: A010 *CONTINUED
Description: S of I-240
Style: Default

Table with columns: STATION, NORTHING, EASTING. Contains data for Element: Circular with stationing, bearing, and curvature information.

Table with columns: STATION, NORTHING, EASTING. Contains data for Element: Linear with stationing and bearing information.

Project Name: EC-1060*Crossroads
Description: survey alg for Crossroads Interchange
Horizontal Alignment Name: A011
Description: SANTA FE. AVE
Style: Default

Table with columns: STATION, NORTHING, EASTING. Contains data for Element: Linear with stationing and bearing information.

Table with columns: STATION, NORTHING, EASTING. Contains data for Element: Linear with stationing and bearing information.

Table with columns: STATION, NORTHING, EASTING. Contains data for Element: Linear with stationing and bearing information.

Project Name: EC-1060*Crossroads
Description: survey alg for Crossroads Interchange
Horizontal Alignment Name: A012
Description: SHIELDS BLVD.
Style: Default

Table with columns: STATION, NORTHING, EASTING. Contains data for Element: Linear with stationing and bearing information.

Table with columns: STATION, NORTHING, EASTING. Contains data for Element: Linear with stationing and bearing information.

Project Name: EC-1060*Crossroads
Description: survey alg for Crossroads Interchange
Horizontal Alignment Name: A013
Description: POLE RD.
Style: Default

Table with columns: STATION, NORTHING, EASTING. Contains data for Element: Linear with stationing and bearing information.

Table with columns: STATION, NORTHING, EASTING. Contains data for Element: Linear with stationing and bearing information.

Project Name: EC-1060*Crossroads
Description: survey alg for Crossroads Interchange
Horizontal Alignment Name: A014
Description: EASTERN AVE.
Style: Default

Table with columns: STATION, NORTHING, EASTING. Contains data for Element: Linear and Element: Circular with stationing, bearing, and curvature information.

Project Name: EC-1060*Crossroads
Description: SURVEY ALG FOR CROSSROADS INTERCHANGE
Horizontal Alignment Name: A015
Description: R.R. BNSF
Style: Default

Table with columns: STATION, NORTHING, EASTING. Contains data for Element: Linear with stationing and bearing information.

Table with columns: STATION, NORTHING, EASTING. Contains data for Element: Circular with stationing, bearing, and curvature information.

Table with columns: STATION, NORTHING, EASTING. Contains data for Element: Linear with stationing and bearing information.

Table with columns: STATION, NORTHING, EASTING. Contains data for Element: Linear with stationing and bearing information.

Table with columns: PLS, DRAWN, CHECKED, APPROVED, CREW, POE, SWO, PROJECT NO., SHEET NO. Includes POE & ASSOCIATES, OKLAHOMA CITY, OK SURVEY DIVISION and SURVEY DATA SHEET.

90% PLAN
SUBMITTAL
EASTING 3/4/2024

Project Name: EC-1060*Crossroads
Description: survey alg for Crossroads Interchange
Horizontal Alignment Name: A016
Description: CLOVER1
Style: Default

Table with columns: STATION, NORTHING, EASTING. Element: Clothoid. Includes T.S. STA., S.P.I. STA., S.C. STA., Entrance Radius, Exit Radius, Length, Angle, Constant, Long Tangent, Short Tangent, Long Chord, Xs, Ys, P, K, Tangent Direction, Radial Direction, Chord Direction, Radial Direction, Tangent Direction.

Table with columns: STATION, NORTHING, EASTING. Element: Circular. Includes S.C. STA., C.C. STA., S.T. STA., Entrance Radius, Exit Radius, Length, Angle, Degree of Curvature(Arc), Length, Tangent, Chord, Middle Ordinate, External, Tangent Direction, Radial Direction, Chord Direction, Radial Direction, Tangent Direction.

Table with columns: STATION, NORTHING, EASTING. Element: Clothoid. Includes C.S. STA., S.P.I. STA., S.T. STA., Entrance Radius, Exit Radius, Length, Angle, Constant, Long Tangent, Short Tangent, Long Chord, Xs, Ys, P, K, Tangent Direction, Radial Direction, Chord Direction, Radial Direction, Tangent Direction.

Project Name: EC-1060*Crossroads
Description: survey alg for Crossroads Interchange
Horizontal Alignment Name: A017
Description: CLOVER2
Style: Default

Table with columns: STATION, NORTHING, EASTING. Element: Clothoid. Includes T.S. STA., S.P.I. STA., S.C. STA., Entrance Radius, Exit Radius, Length, Angle, Constant, Long Tangent, Short Tangent, Long Chord, Xs, Ys, P, K, Tangent Direction, Radial Direction, Chord Direction, Radial Direction, Tangent Direction.

Project Name: EC-1060*Crossroads
Description: survey alg for Crossroads Interchange
Horizontal Alignment Name: A017 *CONTINUED
Description: CLOVER2
Style: Default

Table with columns: STATION, NORTHING, EASTING. Element: Circular. Includes S.C. STA., C.C. STA., S.T. STA., Entrance Radius, Exit Radius, Length, Angle, Degree of Curvature(Arc), Length, Tangent, Chord, Middle Ordinate, External, Tangent Direction, Radial Direction, Chord Direction, Radial Direction, Tangent Direction.

Table with columns: STATION, NORTHING, EASTING. Element: Clothoid. Includes C.S. STA., S.P.I. STA., S.T. STA., Entrance Radius, Exit Radius, Length, Angle, Constant, Long Tangent, Short Tangent, Long Chord, Xs, Ys, P, K, Tangent Direction, Radial Direction, Chord Direction, Radial Direction, Tangent Direction.

Project Name: EC-1060*Crossroads
Description: survey alg for Crossroads Interchange
Horizontal Alignment Name: A018
Description: CLOVER3
Style: Default

Table with columns: STATION, NORTHING, EASTING. Element: Clothoid. Includes T.S. STA., S.P.I. STA., S.C. STA., Entrance Radius, Exit Radius, Length, Angle, Constant, Long Tangent, Short Tangent, Long Chord, Xs, Ys, P, K, Tangent Direction, Radial Direction, Chord Direction, Radial Direction, Tangent Direction.

Table with columns: STATION, NORTHING, EASTING. Element: Circular. Includes S.C. STA., C.C. STA., S.T. STA., Entrance Radius, Exit Radius, Length, Angle, Degree of Curvature(Arc), Length, Tangent, Chord, Middle Ordinate, External, Tangent Direction, Radial Direction, Chord Direction, Radial Direction, Tangent Direction.

Project Name: EC-1060*Crossroads
Description: survey alg for Crossroads Interchange
Horizontal Alignment Name: A018 *CONTINUED
Description: CLOVER3
Style: Default

Table with columns: STATION, NORTHING, EASTING. Element: Clothoid. Includes C.S. STA., S.P.I. STA., S.T. STA., Entrance Radius, Exit Radius, Length, Angle, Constant, Long Tangent, Short Tangent, Long Chord, Xs, Ys, P, K, Tangent Direction, Radial Direction, Chord Direction, Radial Direction, Tangent Direction.

Project Name: EC-1060*Crossroads
Description: survey alg for Crossroads Interchange
Horizontal Alignment Name: A019
Description: CLOVER4
Style: Default

Table with columns: STATION, NORTHING, EASTING. Element: Clothoid. Includes T.S. STA., S.P.I. STA., S.C. STA., Entrance Radius, Exit Radius, Length, Angle, Constant, Long Tangent, Short Tangent, Long Chord, Xs, Ys, P, K, Tangent Direction, Radial Direction, Chord Direction, Radial Direction, Tangent Direction.

Table with columns: STATION, NORTHING, EASTING. Element: Circular. Includes S.C. STA., C.C. STA., S.T. STA., Entrance Radius, Exit Radius, Length, Angle, Degree of Curvature(Arc), Length, Tangent, Chord, Middle Ordinate, External, Tangent Direction, Radial Direction, Chord Direction, Radial Direction, Tangent Direction.

Table with columns: STATION, NORTHING, EASTING. Element: Clothoid. Includes C.S. STA., S.P.I. STA., S.T. STA., Entrance Radius, Exit Radius, Length, Angle, Constant, Long Tangent, Short Tangent, Long Chord, Xs, Ys, P, K, Tangent Direction, Radial Direction, Chord Direction, Radial Direction, Tangent Direction.

Table with columns: PLS, DRAWN, CHECKED, APPROVED, CREW, POE, SWO, PROJECT NO., SHEET NO. Includes POE & ASSOCIATES, OKLAHOMA CITY, OK SURVEY DIVISION SURVEY DATA SHEET.

Project Name: EC-1060*Crossroads
Description: survey alg for Crossroads Interchange
Horizontal Alignment Name: A020
Description: SANTA FE/SIELDS BLVD
Style: Default

Table with 4 columns: STATION, NORTHING, EASTING, and data for Element: Circular. Includes PC, P.I., C.C., P.T. STA. coordinates and curve data like Radius, Delta, Degree of Curvature, etc.

Table with 4 columns: STATION, NORTHING, EASTING, and data for Element: Linear. Includes P.T. STA., PC STA. coordinates and Tangent Direction/Length.

Table with 4 columns: STATION, NORTHING, EASTING, and data for Element: Circular. Includes PC, P.I., C.C., P.T. STA. coordinates and curve data.

Table with 4 columns: STATION, NORTHING, EASTING, and data for Element: Linear. Includes P.T. STA., P.O.E. STA. coordinates and Tangent Direction/Length.

Project Name: EC-1060*Crossroads
Description: survey alg for Crossroads Interchange
Horizontal Alignment Name: A021
Description: SANTA FE/SIELDS BLVD
Style: Default

Table with 4 columns: STATION, NORTHING, EASTING, and data for Element: Circular. Includes PC, P.I., C.C., P.T. STA. coordinates and curve data.

Table with 4 columns: STATION, NORTHING, EASTING, and data for Element: Linear. Includes P.T. STA., PC STA. coordinates and Tangent Direction/Length.

Table with 4 columns: STATION, NORTHING, EASTING, and data for Element: Circular. Includes PC, P.I., C.C., P.T. STA. coordinates and curve data.

Project Name: EC-1060*Crossroads
Description: survey alg for Crossroads Interchange
Horizontal Alignment Name: A021 *CONTINUED
Description: SANTA FE/SIELDS BLVD
Style: Default

Table with 4 columns: STATION, NORTHING, EASTING, and data for Element: Linear. Includes P.T. STA., P.O.E. STA. coordinates and Tangent Direction/Length.

Project Name: EC-1060*Crossroads
Description: survey alg for Crossroads Interchange
Horizontal Alignment Name: A022
Description: SHIELDS BLVD/BYERS AVE
Style: Default

Table with 4 columns: STATION, NORTHING, EASTING, and data for Element: Linear. Includes P.O.B. STA., PC STA. coordinates and Tangent Direction/Length.

Table with 4 columns: STATION, NORTHING, EASTING, and data for Element: Circular. Includes PC, P.I., C.C., P.T. STA. coordinates and curve data.

Table with 4 columns: STATION, NORTHING, EASTING, and data for Element: Linear. Includes P.T. STA., PC STA. coordinates and Tangent Direction/Length.

Table with 4 columns: STATION, NORTHING, EASTING, and data for Element: Circular. Includes PC, P.I., C.C., P.T. STA. coordinates and curve data.

Table with 4 columns: STATION, NORTHING, EASTING, and data for Element: Circular. Includes PC, P.I., C.C., P.T. STA. coordinates and curve data.

Project Name: EC-1060*Crossroads
Description: survey alg for Crossroads Interchange
Horizontal Alignment Name: A023
Description: SHIELDS BLVD/BYERS AVE
Style: Default

Table with 4 columns: STATION, NORTHING, EASTING, and data for Element: Linear. Includes P.O.B. STA., PC STA. coordinates and Tangent Direction/Length.

Table with 4 columns: STATION, NORTHING, EASTING, and data for Element: Circular. Includes PC, P.I., C.C., P.T. STA. coordinates and curve data.

Table with 4 columns: STATION, NORTHING, EASTING, and data for Element: Linear. Includes P.T. STA., PC STA. coordinates and Tangent Direction/Length.

Table with 4 columns: STATION, NORTHING, EASTING, and data for Element: Circular. Includes PC, P.I., C.C., P.T. STA. coordinates and curve data.

Project Name: EC-1060*Crossroads
Description: survey alg for Crossroads Interchange
Horizontal Alignment Name: A024
Description: NE of Pole Rd
Style: Default

Table with 4 columns: STATION, NORTHING, EASTING, and data for Element: Circular. Includes PC, P.I., C.C., P.T. STA. coordinates and curve data.

90% PLAN
SUBMITTAL
3/4/2024

Table with 4 columns: PLS, DRAWN, CHECKED, APPROVED, CREW. Includes title 'SURVEY DATA SHEET', date '3/4/2024', project no. '090321081', sheet no. 'S023', and location 'OKLAHOMA COUNTY'.

90% PLAN
SUBMITTAL
EASTING 3/4/2024

Project Name: EC-1060*Crossroads
Description: survey alg for Crossroads Interchange
Horizontal Alignment Name: A025
Description: SE of Pole Rd
Style: Default

Table with columns STATION, NORTHING, EASTING. Contains data for Element: Circular with PC, P.I., C.C., P.T. STA. coordinates and geometric properties like Radius, Delta, Degree of Curvature, Length, Tangent, Chord, Middle Ordinate, External, Tangent Direction, Radial Direction, Chord Direction, Radial Direction.

Project Name: EC-1060*Crossroads
Description: survey alg for Crossroads Interchange
Horizontal Alignment Name: A026
Description: RAMP E of Eastern Ave
Style: Default

Table with columns STATION, NORTHING, EASTING. Contains data for Element: Linear with P.O.B., PC, STA. coordinates and Tangent Direction, Tangent Length.

Table with columns STATION, NORTHING, EASTING. Contains data for Element: Circular with PC, P.I., C.C., P.T. STA. coordinates and geometric properties like Radius, Delta, Degree of Curvature, Length, Tangent, Chord, Middle Ordinate, External, Tangent Direction, Radial Direction, Chord Direction, Radial Direction.

Table with columns STATION, NORTHING, EASTING. Contains data for Element: Linear with P.T., P.I., STA. coordinates and Tangent Direction, Tangent Length.

Table with columns STATION, NORTHING, EASTING. Contains data for Element: Linear with P.I., P.O.E., STA. coordinates and Tangent Direction, Tangent Length.

Project Name: EC-1060*Crossroads
Description: survey alg for Crossroads Interchange
Horizontal Alignment Name: A027
Description: RAMP W of Eastern Ave
Style: Default

Table with columns STATION, NORTHING, EASTING. Contains data for Element: Linear with P.O.B., PC, STA. coordinates and Tangent Direction, Tangent Length.

Table with columns STATION, NORTHING, EASTING. Contains data for Element: Circular with PC, P.I., C.C., P.T. STA. coordinates and geometric properties like Radius, Delta, Degree of Curvature, Length, Tangent, Chord, Middle Ordinate, External, Tangent Direction, Radial Direction, Chord Direction, Radial Direction.

Project Name: EC-1060*Crossroads
Description: survey alg for Crossroads Interchange
Horizontal Alignment Name: A027 *CONTINUED
Description: RAMP W of Eastern Ave
Style: Default

Table with columns STATION, NORTHING, EASTING. Contains data for Element: Linear with P.T., P.I., STA. coordinates and Tangent Direction, Tangent Length.

Table with columns STATION, NORTHING, EASTING. Contains data for Element: Circular with PC, P.I., C.C., P.C.C. STA. coordinates and geometric properties like Radius, Delta, Degree of Curvature, Length, Tangent, Chord, Middle Ordinate, External, Tangent Direction, Radial Direction, Chord Direction, Radial Direction.

Table with columns STATION, NORTHING, EASTING. Contains data for Element: Circular with P.C.C., P.I., C.C., P.T. STA. coordinates and geometric properties like Radius, Delta, Degree of Curvature, Length, Tangent, Chord, Middle Ordinate, External, Tangent Direction, Radial Direction, Chord Direction, Radial Direction.

Table with columns STATION, NORTHING, EASTING. Contains data for Element: Linear with P.T., PC, STA. coordinates and Tangent Direction, Tangent Length.

Table with columns STATION, NORTHING, EASTING. Contains data for Element: Circular with PC, P.I., C.C., P.T. STA. coordinates and geometric properties like Radius, Delta, Degree of Curvature, Length, Tangent, Chord, Middle Ordinate, External, Tangent Direction, Radial Direction, Chord Direction, Radial Direction.

Table with columns STATION, NORTHING, EASTING. Contains data for Element: Linear with P.T., P.O.E., STA. coordinates and Tangent Direction, Tangent Length.

Project Name: EC-1060*Crossroads
Description: survey alg for Crossroads Interchange
Horizontal Alignment Name: A028
Description: RAMP SE of I-35
Style: Default

Table with columns STATION, NORTHING, EASTING. Contains data for Element: Circular with PC, P.I., C.C., P.T. STA. coordinates and geometric properties like Radius, Delta, Degree of Curvature, Length, Tangent, Chord, Middle Ordinate, External, Tangent Direction, Radial Direction, Chord Direction, Radial Direction.

Project Name: EC-1060*Crossroads
Description: survey alg for Crossroads Interchange
Horizontal Alignment Name: A029
Description: SE 59TH ST
Style: Default

Table with columns STATION, NORTHING, EASTING. Contains data for Element: Linear with P.O.B., P.I., STA. coordinates and Tangent Direction, Tangent Length.

Table with columns STATION, NORTHING, EASTING. Contains data for Element: Linear with P.I., P.I., STA. coordinates and Tangent Direction, Tangent Length.

Table with columns STATION, NORTHING, EASTING. Contains data for Element: Linear with P.I., P.O.E., STA. coordinates and Tangent Direction, Tangent Length.

Project Name: EC-1060*Crossroads
Description: survey alg for Crossroads Interchange
Horizontal Alignment Name: A030
Description: SE 66TH ST
Style: Default

Table with columns STATION, NORTHING, EASTING. Contains data for Element: Linear with P.O.B., P.I., STA. coordinates and Tangent Direction, Tangent Length.

Table with columns STATION, NORTHING, EASTING. Contains data for Element: Linear with P.I., P.I., STA. coordinates and Tangent Direction, Tangent Length.

Table with columns STATION, NORTHING, EASTING. Contains data for Element: Linear with P.I., P.O.E., STA. coordinates and Tangent Direction, Tangent Length.

Project Name: EC-1060*Crossroads
Description: survey alg for Crossroads Interchange
Horizontal Alignment Name: A031
Description: SE 82ND ST
Style: Default

Table with columns STATION, NORTHING, EASTING. Contains data for Element: Linear with P.O.B., P.I., STA. coordinates and Tangent Direction, Tangent Length.

Table with columns STATION, NORTHING, EASTING. Contains data for Element: Linear with P.I., P.I., STA. coordinates and Tangent Direction, Tangent Length.

Table with columns STATION, NORTHING, EASTING. Contains data for Element: Linear with P.I., P.O.E., STA. coordinates and Tangent Direction, Tangent Length.

Table with columns PLS, DRAWN, CHECKED, APPROVED, CREW, POE, SWO, PROJECT NO., SHEET NO. Includes POE & ASSOCIATES, OKLAHOMA CITY, OK SURVEY DIVISION and SURVEY DATA SHEET.

SEC.28, T-11-N, R-3-W

SEC.27, T-11-N, R-3-W

SEC.33, T-11-N, R-3-W

SEC.34, T-11-N, R-3-W

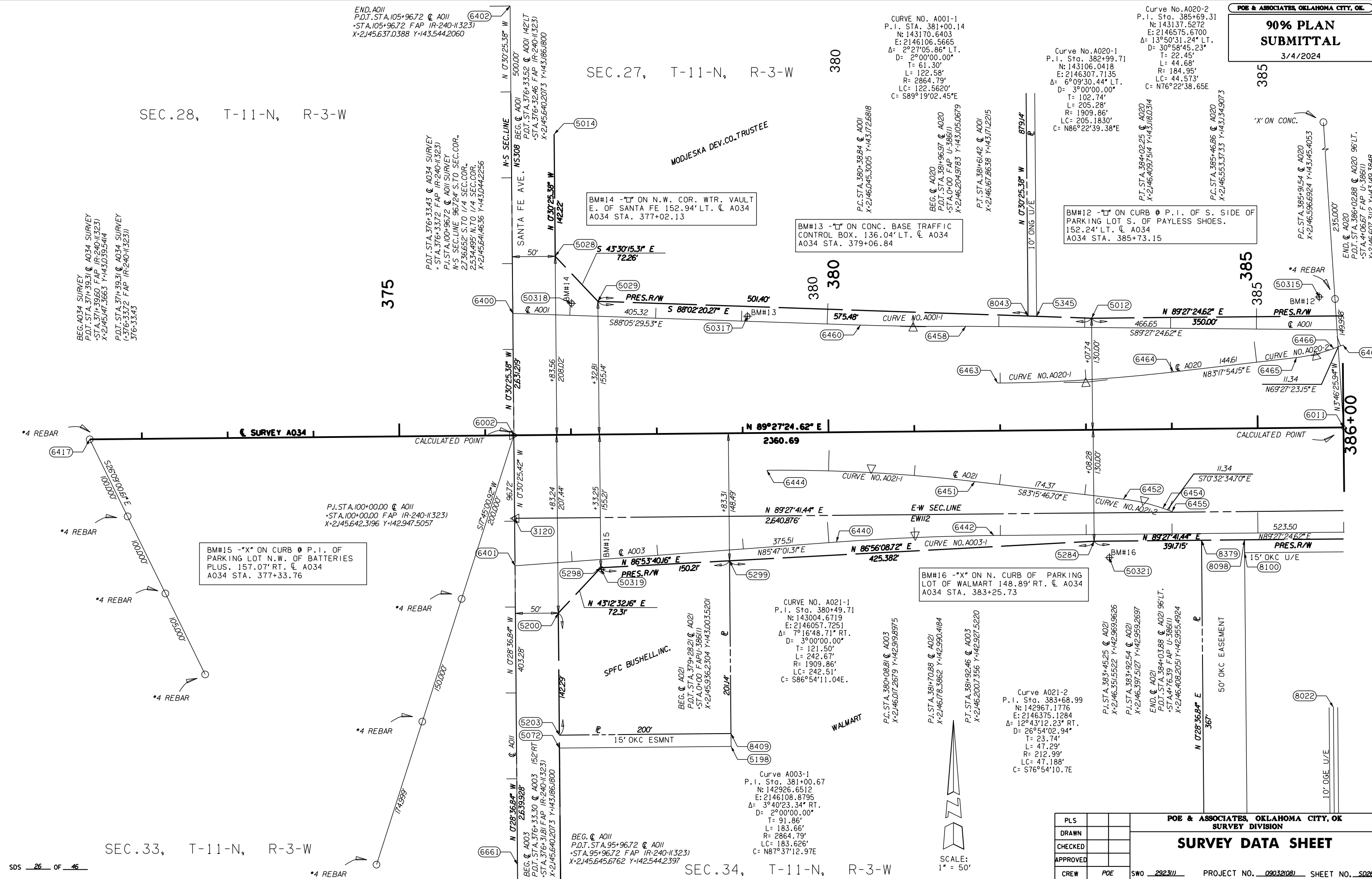

PLS		POE & ASSOCIATES, OKLAHOMA CITY, OK	
DRAWN		SURVEY DIVISION	
CHECKED		SURVEY DATA SHEET	
APPROVED			
CREW	POE	SWO 2923111	PROJECT NO. 090321081 SHEET NO. SD26

SEC. 27, T-11-N, R-3-W

BM#11 - "X" ON CURB IN PARKING LOT W. OF SHIELDS 453.49' LT. @ A034 (CONTROL PT. "0-55-1838") A034 STA. 391+00.77

BM#10 - "X" ON CURB @ P.I. S. COR. PARKING LOT OF VALERO GAS STA. 176.68' LT. @ A034 A034 STA. 394+01.73

BM#9 - "X" ON CURB @ INLET S. PARKING LOT OF HOME DEPOT 175.60' LT. @ A034 A034 STA. 399+94.10

CURVE NO. A001-3
 P.I. STA. 400+04.34
 N: 143179.9811
 E: 2148009.8505
 $\Delta = 1^{\circ}54'06.00''$ LT.
 $D = 1^{\circ}00'00.00''$
 $T = 95.09'$
 $L = 190.17'$
 $R = 5729.58'$
 $LC = 190.1580'$
 $C = S89^{\circ}35'32.38''E$

CURVE NO. A001-2
 P.I. STA. 387+50.12
 N: 143167.9547
 E: 2146756.5375
 $\Delta = 2^{\circ}26'26.28''$ LT.
 $D = 1^{\circ}00'00.00''$
 $T = 122.05'$
 $L = 244.06'$
 $R = 5729.58'$
 $LC = 244.045'$
 $C = N88^{\circ}14'11.48''E$

Curve NO. A003-2
 P.I. Sta. 388+00.60
 N: 142933.2871
 E: 2146808.8480
 $\Delta = 2^{\circ}32'19.60''$ RT.
 $D = 1^{\circ}30'00.00''$
 $T = 84.64'$
 $L = 169.25'$
 $R = 3819.72'$
 $LC = 169.238'$
 $C = S89^{\circ}16'25.57''E$

BM#18 - "X" ON E. CURB OF 3RD ENTR. FROM W. ON N. SIDE NISSAN DEALERSHIP. 139.51' RT. @ A034 A034 STA. 389+27.33

BM#20 - "X" ON CONC. BASE OF LIGHT POLE N. OF ENTERPRISE RENTAL. 155.12' RT. @ A034 A034 STA. 395+58.73

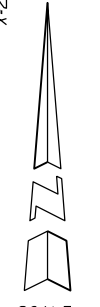

PLS				POE & ASSOCIATES, OKLAHOMA CITY, OK SURVEY DIVISION SURVEY DATA SHEET
DRAWN				
CHECKED				
APPROVED				
CREW	POE	SWO	2923111	

PROJECT NO. 090321081 SHEET NO. 502Z
 OKLAHOMA COUNTY

SEC. 34, T-11-N, R-3-W

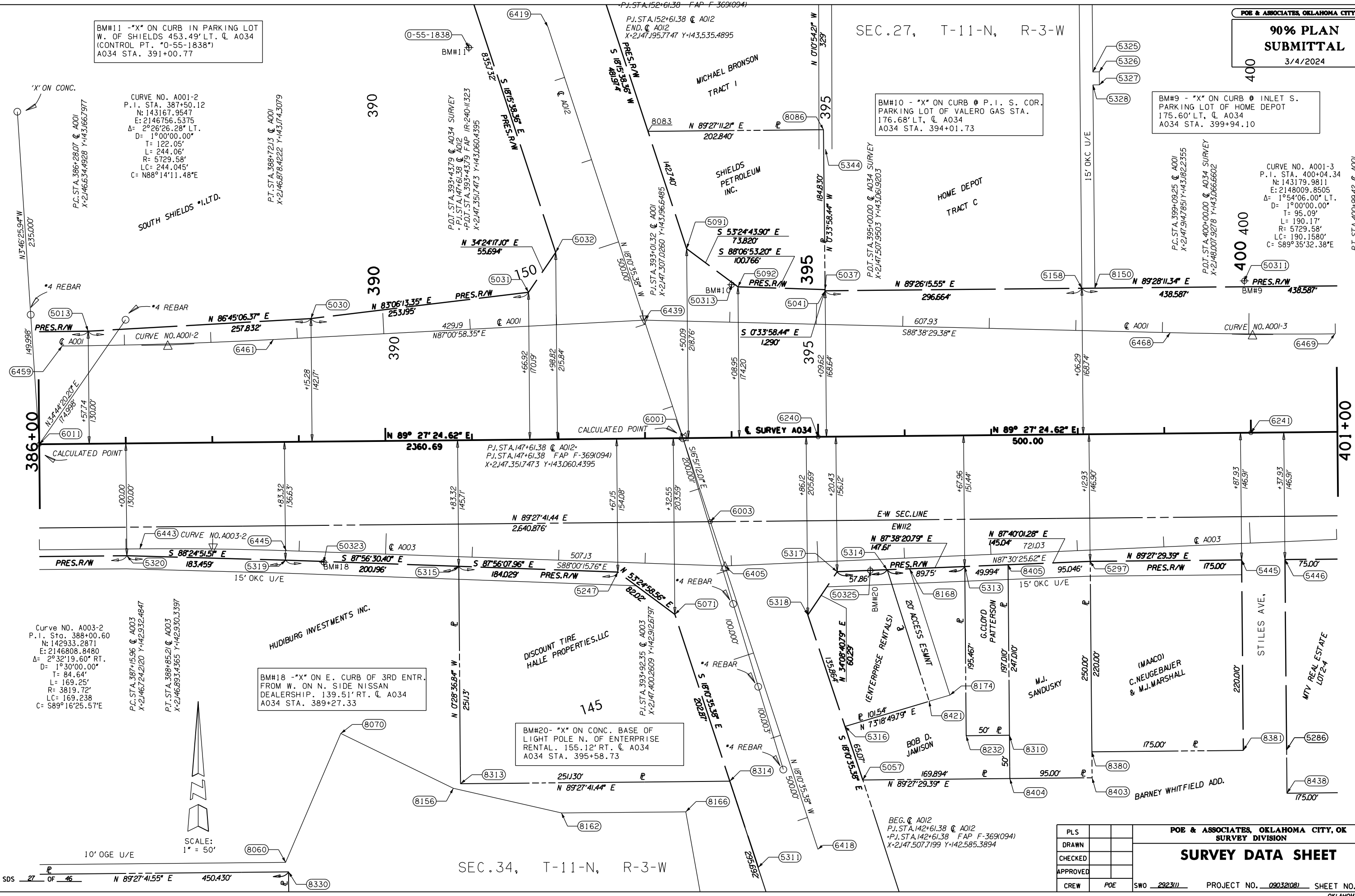

POE & ASSOCIATES, OKLAHOMA CITY, OK.
90% PLAN SUBMITTAL
 3/4/2024

SEC. 27, T-11-N, R-3-W

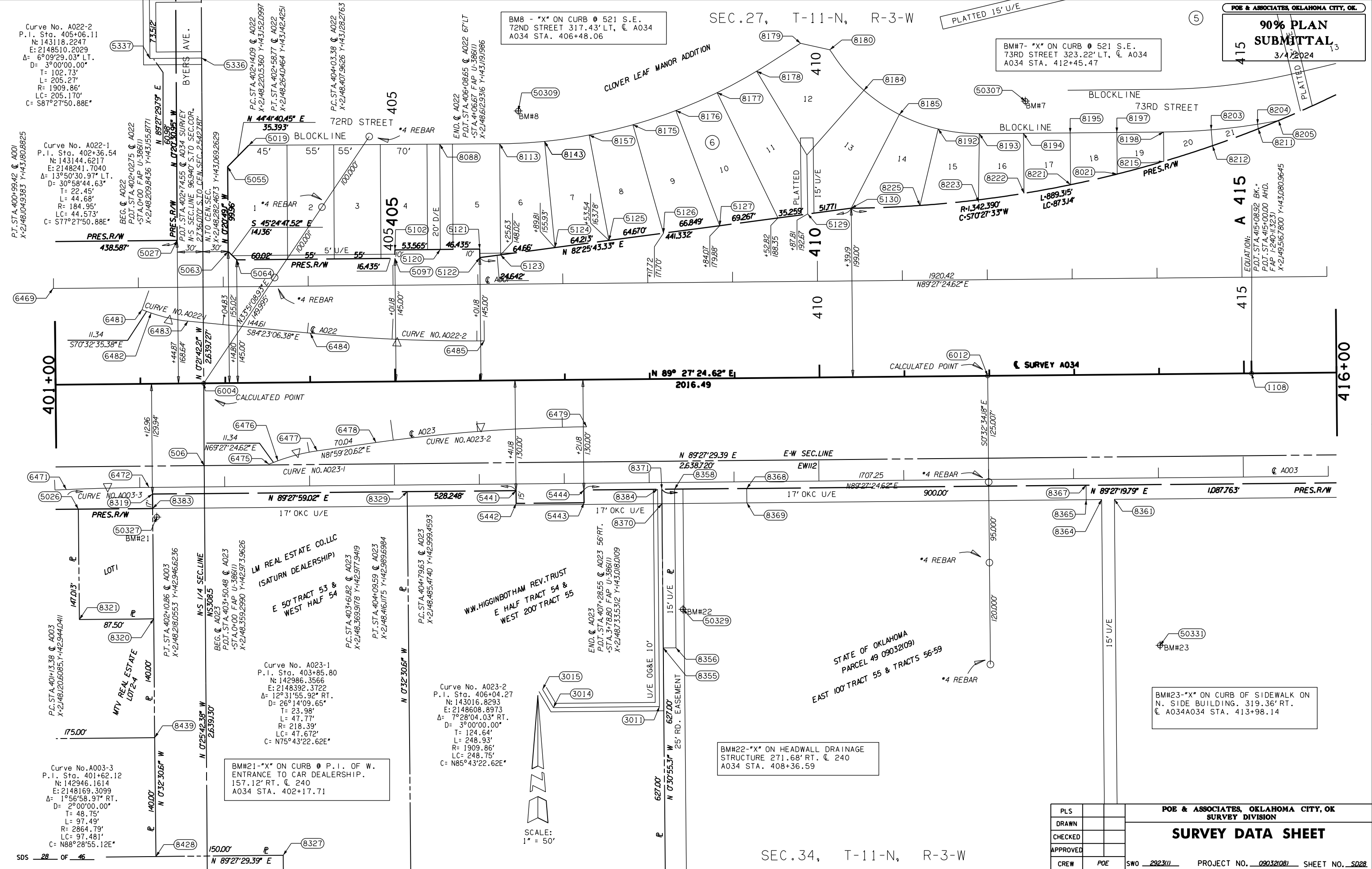

Curve No. A022-2
 P.I. Sta. 405+06.11
 N: 143118.2247
 E: 2148510.2029
 $\Delta = 69^{\circ}09'29.03''$ LT.
 $D = 3^{\circ}00'00.00''$
 $T = 102.73'$
 $L = 205.27'$
 $R = 1909.86'$
 $LC = 205.170'$
 $C = S87^{\circ}27'50.88E'$

Curve No. A022-1
 P.I. Sta. 402+36.54
 N: 143144.6217
 E: 2148241.7040
 $\Delta = 13^{\circ}50'30.97''$ LT.
 $D = 30^{\circ}58'44.63''$
 $T = 22.45'$
 $L = 44.68'$
 $R = 184.95'$
 $LC = 44.573'$
 $C = S77^{\circ}27'50.88E'$

Curve No. A023-1
 P.I. Sta. 403+85.80
 N: 142986.3566
 E: 2148392.3722
 $\Delta = 12^{\circ}31'55.92''$ RT.
 $D = 26^{\circ}14'09.65''$
 $T = 23.98'$
 $L = 47.77'$
 $R = 218.39'$
 $LC = 47.672'$
 $C = N75^{\circ}43'22.62E'$

Curve No. A023-2
 P.I. Sta. 406+04.27
 N: 143016.8293
 E: 2148608.8973
 $\Delta = 7^{\circ}28'04.03''$ RT.
 $D = 3^{\circ}00'00.00''$
 $T = 124.64'$
 $L = 248.93'$
 $R = 1909.86'$
 $LC = 248.75'$
 $C = N85^{\circ}43'22.62E'$

BM#21 - "X" ON CURB @ P.I. OF W. ENTRANCE TO CAR DEALERSHIP.
 157.12' RT. @ 240
 A034 STA. 402+17.71

BM#22 - "X" ON HEADWALL DRAINAGE STRUCTURE 271.68' RT. @ 240
 A034 STA. 408+36.59

BM#23 - "X" ON CURB OF SIDEWALK ON N. SIDE BUILDING. 319.36' RT. @ A034A034 STA. 413+98.14

PLS		POE & ASSOCIATES, OKLAHOMA CITY, OK	
DRAWN		SURVEY DIVISION	
CHECKED		SURVEY DATA SHEET	
APPROVED			
CREW	POE		
		SWO 2923111	PROJECT NO. 09032019 SHEET NO. 5028
OKLAHOMA COUNTY			

SEC. 34, T-11-N, R-3-W

90% PLAN SUBMITTAL
3/4/2024

85

P.O.T. STA. 85+00.00 @ A035 SURVEY
X=2,150,821.5375 Y=143,519.2099

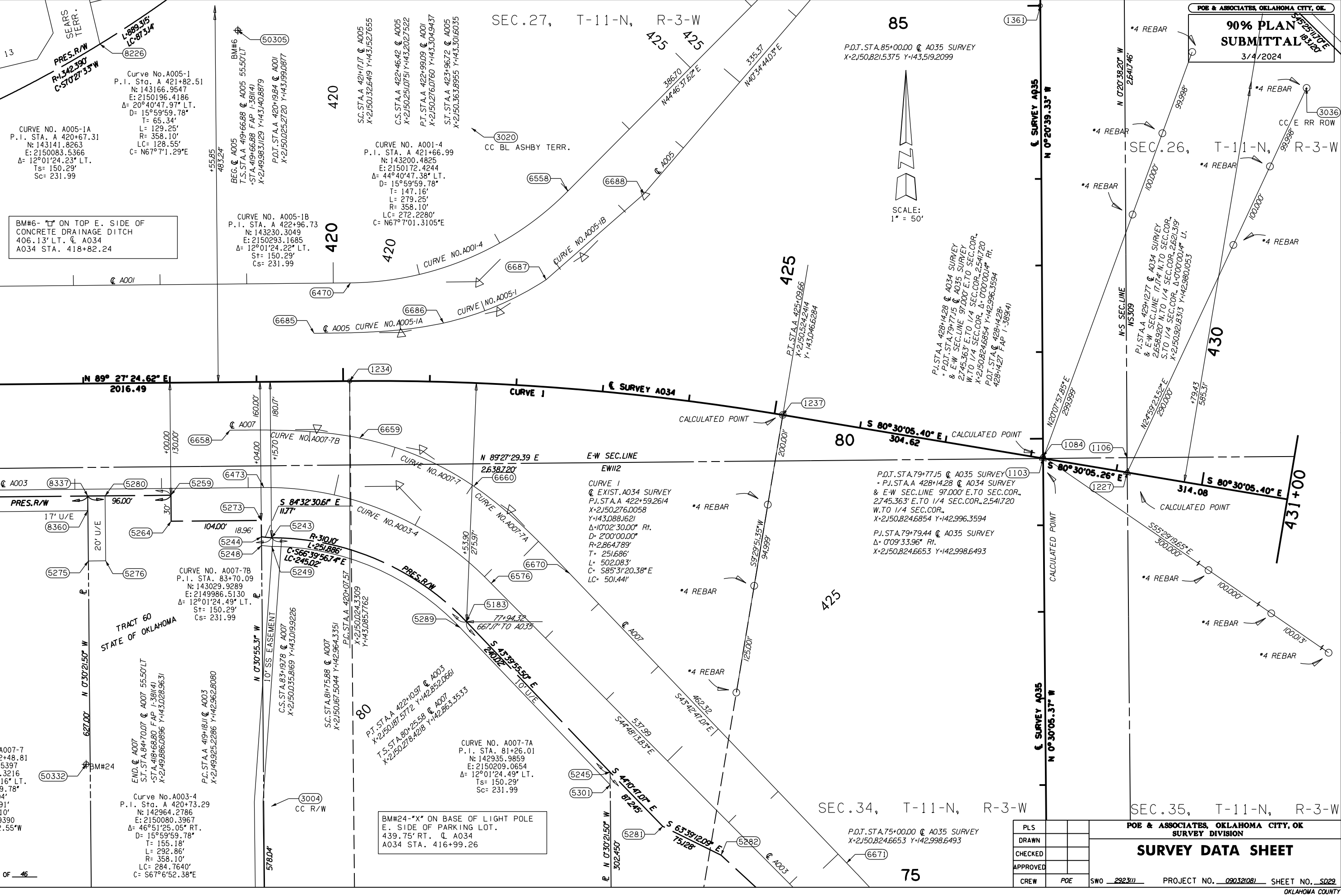
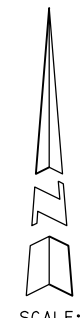

CURVE NO. A005-1A
P.I. STA. A 420+67.31
N: 143141.8263
E: 2150083.5366
Δ = 12°01'24.23" LT.
Ts = 150.29'
Sc = 231.99

BM#6- "X" ON TOP E. SIDE OF CONCRETE DRAINAGE DITCH
406.13' LT. @ A034
A034 STA. 418+82.24

CURVE NO. A005-1B
P.I. STA. A 422+96.73
N: 143230.3049
E: 2150293.1685
Δ = 12°01'24.22" LT.
Ts = 150.29'
Sc = 231.99

CURVE NO. A001-4
P.I. STA. A 421+66.99
N: 143200.4825
E: 2150172.4244
Δ = 44°40'47.38" LT.
D = 15°59'59.78"
T = 147.16'
L = 279.25'
R = 358.10'
LC = 272.2280'
C = N67°01.3105"E

CURVE NO. A007-7
P.I. STA. 82+48.81
N: 143005.5397
E: 2150107.3216
Δ = 23°01'29.16" LT.
D = 15°59'59.78"
T = 72.94'
L = 143.91'
R = 358.10'
LC = 142.9390
C = N67°6'52.55"W

Curve No. A003-4
P.I. Sta. A 420+73.29
N: 142964.2786
E: 2150080.3967
Δ = 46°51'25.05" RT.
D = 15°59'59.78"
T = 155.18'
L = 292.86'
R = 358.10'
LC = 284.7640'
C = S67°6'52.38"E

CURVE NO. A007-7A
P.I. STA. 81+26.01
N: 142935.9859
E: 2150209.0654
Δ = 12°01'24.49" LT.
Ts = 150.29'
Sc = 231.99

BM#24-"X" ON BASE OF LIGHT POLE E. SIDE OF PARKING LOT.
439.75' RT. @ A034
A034 STA. 416+99.26

P.O.T. STA. 79+77.15 @ A035 SURVEY (1103)
P.I. STA. A 428+14.28 @ A034 SURVEY
& E-W SEC. LINE 97.000' E. TO SEC. COR.,
2745.363' E. TO 1/4 SEC. COR., 2.541720
W. TO 1/4 SEC. COR.,
X=2,150,824.6854 Y=142,996.3594

P.I. STA. 79+79.44 @ A035 SURVEY
Δ = 0°09'33.96" RT.
X=2,150,824.6653 Y=142,998.6493

P.O.T. STA. 75+00.00 @ A035 SURVEY
X=2,150,824.6653 Y=142,998.6493

PLS	
DRAWN	
CHECKED	
APPROVED	
CREW	POE

POE & ASSOCIATES, OKLAHOMA CITY, OK
SURVEY DIVISION
SURVEY DATA SHEET
PROJECT NO. 090321081 SHEET NO. SD29
OKLAHOMA COUNTY

BM#53-BAR & CAP (CONTROL POINT *0-55-1841) 286.71' LT. @ A034 A034 STA. 444+45.20 3/4/2024

BM#52 - "X" ON TOP OF CURB S. OF LIGHT POLE S.E. OF THEATRE 308.74' RT. @ A034 A034 STA. 445+56.60

SEC. 26, T-11-N, R-3-W

BM#54 - "X" ON TOP OF CURB IN E. PARKING LOT OF TEXAS ROADHOUSE 209.30' RT. @ A034 A034 STA. 439+22.55

BM#56 - "X" ON TOP OF CURB S.E. PARKING LOT OF TIRE REPAIR 541.94' RT. @ A034 A034 STA. 433+59.70

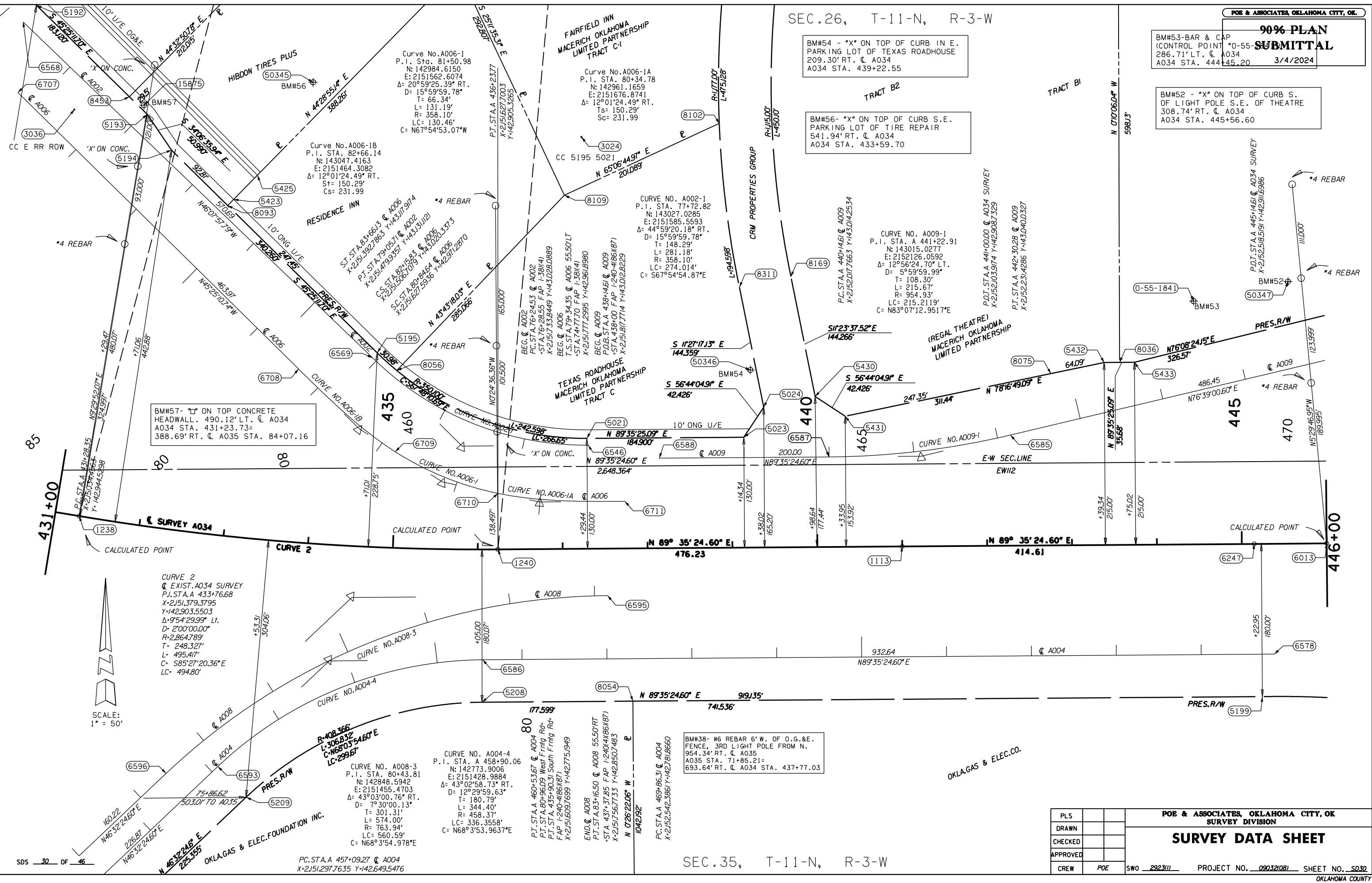

BM#57 - "T" ON TOP CONCRETE HEADWALL. 490.12' LT. @ A034 A034 STA. 431+23.73= 388.69' RT. @ A035 STA. 84+07.16

CURVE 2 @ EXIST. A034 SURVEY P.I. STA. A 433+76.68 X=2151.379, 3795 Y=142,903,5503 Δ=9°54'29.99" Lt. D=2'00"00.00" R=2,864,789' T= 248,327' L= 495,417' C= 585°27'20.36"E LC= 494,80'

CURVE NO. A008-3 P.I. STA. 80+43.81 N: 142848.5942 E: 2151455.4703 Δ= 43°03'00.76" RT. D= 7°30'00.13" T= 301.31' L= 574.00' R= 763.94' LC= 560.59' C= N68°3'54.978"E

CURVE NO. A004-4 P.I. STA. A 458+90.06 N: 142773.9006 E: 2151428.9884 Δ= 43°02'58.73" RT. D= 12°29'59.63" T= 180.79' L= 344.40' R= 458.37' LC= 336.3558' C= N68°3'53.9637"E

CURVE NO. A008-3 P.I. STA. 80+43.81 N: 142848.5942 E: 2151455.4703 Δ= 43°03'00.76" RT. D= 7°30'00.13" T= 301.31' L= 574.00' R= 763.94' LC= 560.59' C= N68°3'54.978"E

CURVE NO. A008-3 P.I. STA. 80+43.81 N: 142848.5942 E: 2151455.4703 Δ= 43°03'00.76" RT. D= 7°30'00.13" T= 301.31' L= 574.00' R= 763.94' LC= 560.59' C= N68°3'54.978"E

BM#38- #6 REBAR 6' W. OF O.G.&E. FENCE, 3RD LIGHT POLE FROM N. 954.34' RT. @ A035 A035 STA. 71+85.21= 693.64' RT. @ A034 STA. 437+77.03

SCALE: 1" = 50'

PLS		POE & ASSOCIATES, OKLAHOMA CITY, OK	
DRAWN		SURVEY DIVISION	
CHECKED		SURVEY DATA SHEET	
APPROVED			
CREW	POE	SWO 2923111	PROJECT NO. 090321081 SHEET NO. SD30

SEC. 26, T-11-N, R-3-W

BM#46 - "X" ON CURB @ S.W. COR. PARKING LOT. 317.36' LT. @ A034 A034 STA. 453+12.44

CURVE NO. A015-1
 P.I. STA. 20576+48.20
 N: 144093.4798
 E: 2153994.2466
 $\Delta = 26^\circ 47' 49.38''$ LT.
 $D = 1^\circ 00' 00.00''$
 $T = 1364.82'$
 $L = 2679.70'$
 $R = 5729.58'$
 $LC = 2655.35'$
 $C = S13^\circ 5' 28.2417'' E$

CURVE NO. A009-3
 P.I. STA. A 459+09.33
 N: 143006.0015
 E: 2153870.4757
 $\Delta = 16^\circ 48' 58.04''$ LT.
 $D = 7^\circ 00' 00.03''$
 $T = 120.98'$
 $L = 240.23'$
 $R = 818.51'$
 $LC = 239.3687'$
 $C = S82^\circ 0' 06.378'' E$

SCALE: 1" = 50'

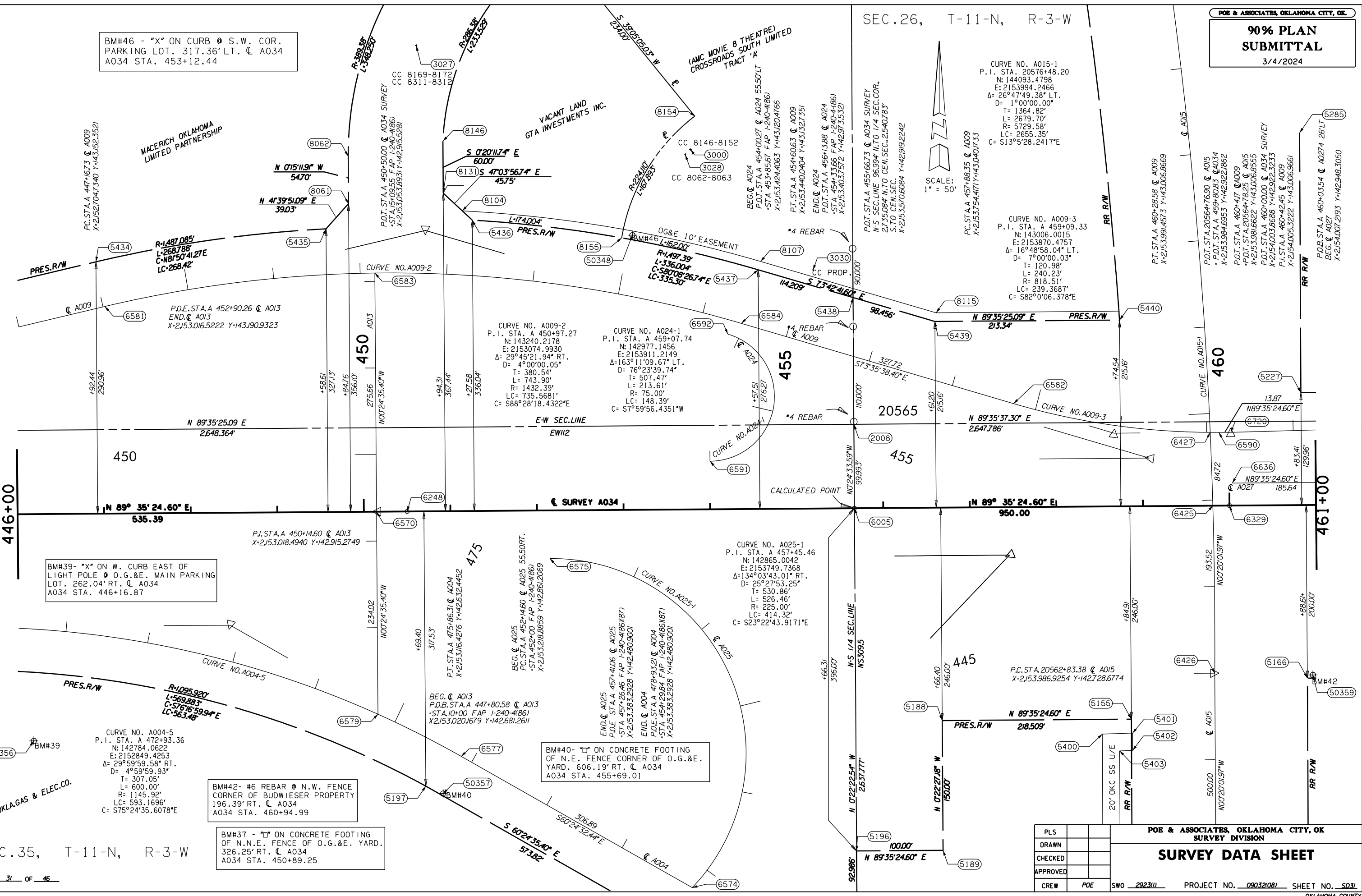

P.O.E. STA. A 452+90.26 @ A013
 END @ A013
 $X = 2153.0165222$ $Y = 143190.9323$

CURVE NO. A009-2
 P.I. STA. A 450+97.27
 N: 143240.2178
 E: 2153074.9930
 $\Delta = 29^\circ 45' 21.94''$ RT.
 $D = 4^\circ 00' 00.05''$
 $T = 380.54'$
 $L = 143.90'$
 $R = 1432.39'$
 $LC = 735.5681'$
 $C = S88^\circ 28' 18.4322'' E$

CURVE NO. A024-1
 P.I. STA. A 459+07.74
 N: 142977.1456
 E: 2153911.2149
 $\Delta = 163^\circ 11' 09.67''$ LT.
 $D = 76^\circ 23' 39.74''$
 $T = 507.47'$
 $L = 213.61'$
 $R = 75.00'$
 $LC = 148.39'$
 $C = S7^\circ 59' 56.4351'' W$

CURVE NO. A025-1
 P.I. STA. A 457+45.46
 N: 142865.0042
 E: 2153749.7368
 $\Delta = 134^\circ 03' 43.01''$ RT.
 $D = 25^\circ 27' 53.25''$
 $T = 530.86'$
 $L = 526.46'$
 $R = 225.00'$
 $LC = 414.32'$
 $C = S23^\circ 22' 43.9171'' E$

CURVE NO. A004-5
 P.I. STA. A 472+93.36
 N: 142784.0622
 E: 2152849.4253
 $\Delta = 29^\circ 59' 59.58''$ RT.
 $D = 4^\circ 59' 59.93''$
 $T = 307.05'$
 $L = 600.00'$
 $R = 1145.92'$
 $LC = 593.1696'$
 $C = S75^\circ 24' 35.6078'' E$

BM#42 - #6 REBAR @ N.W. FENCE CORNER OF BUDWIESER PROPERTY 196.39' RT. @ A034 A034 STA. 460+94.99

BM#37 - "T" ON CONCRETE FOOTING OF N.N.E. FENCE OF O.G.&E. YARD. 326.25' RT. @ A034 A034 STA. 450+89.25

BM#40 - "T" ON CONCRETE FOOTING OF N.E. FENCE CORNER OF O.G.&E. YARD. 606.19' RT. @ A034 A034 STA. 455+69.01

PLS				
DRAWN				
CHECKED				
APPROVED				
CREW	POE	SWO 2923111	PROJECT NO. 090321081	SHEET NO. 5031

POE & ASSOCIATES, OKLAHOMA CITY, OK
 SURVEY DIVISION
SURVEY DATA SHEET
 OKLAHOMA COUNTY

SEC. 35, T-11-N, R-3-W

SEC.26, T-11-N, R-3-W

BM#50- "I" ON TOP OF SANITARY
 SEWER MANHOLE 147.47' LT. C A034
 A034 STA. 464+13.38

BM#49- "I" ON TOP OF CURB @
 S.E. CORNER PARKING LOT.
 178.33' LT. C A034
 A034 STA. 470+82.54

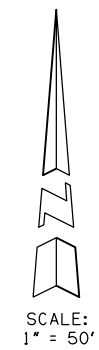

CURVE NO. A009-4
 P.I. STA. A 475+84.63
 N: 143050.2906
 E: 2155546.8960
 $\Delta = 28^{\circ}56'58.63"$ LT.
 $D = 5^{\circ}59'59.99"$
 T = 246.51'
 L = 482.49'
 R = 954.93'
 LC = 477.3778'
 E = N73°37'50.5992"E

CURVE NO. A027-1
 P.I. STA. A 463+03.77
 N: 142948.1609
 E: 2154307.4340
 $\Delta = 1^{\circ}08'45.06"$ LT.
 T = 114.59'
 L = 229.17'
 R = 11459.16'
 LC = 229.1662'
 C = S89°50'12.8675"E

CURVE 3
 C EXIST. A034 SURVEY
 P.I. STA. A 468+91.34
 X=2154895.1883
 Y=142928.6990
 $\Delta = 110^{\circ}00.00"$ Rt.
 D = 0'06"00.00"
 R = 57.295779'
 T = 583.353'
 L = 1166.667'
 C = S89°49'35.40"E
 LC = 1166.647'

CURVE NO. A010-1
 P.I. STA. A 474+82.01
 N: 142824.3679
 E: 2155483.6784
 $\Delta = 23^{\circ}54'46.77"$ RT.
 $D = 4^{\circ}29'59.99"$
 T = 269.63'
 L = 531.40'
 R = 1273.24'
 LC = 527.5515'
 C = S73°43'16.0154"E

BEG. C A010
 P.O.T. STA. A 467+13.00 C A010 44' RT
 STA. 467+00 FAP 1-240-4186157
 X=2154716.8604 Y=142882.3266

PBO DEV. COMPANY
 (BUDWEISER-BUSCH)

BM#43- #6 X 30" LG. REBAR 197.10'
 RT. C A034
 A034 STA. 472+62.48

BM#43- #6 X 30" LG. REBAR 197.10'
 RT. C A034
 A034 STA. 472+62.48

SEC.35, T-11-N, R-3-W

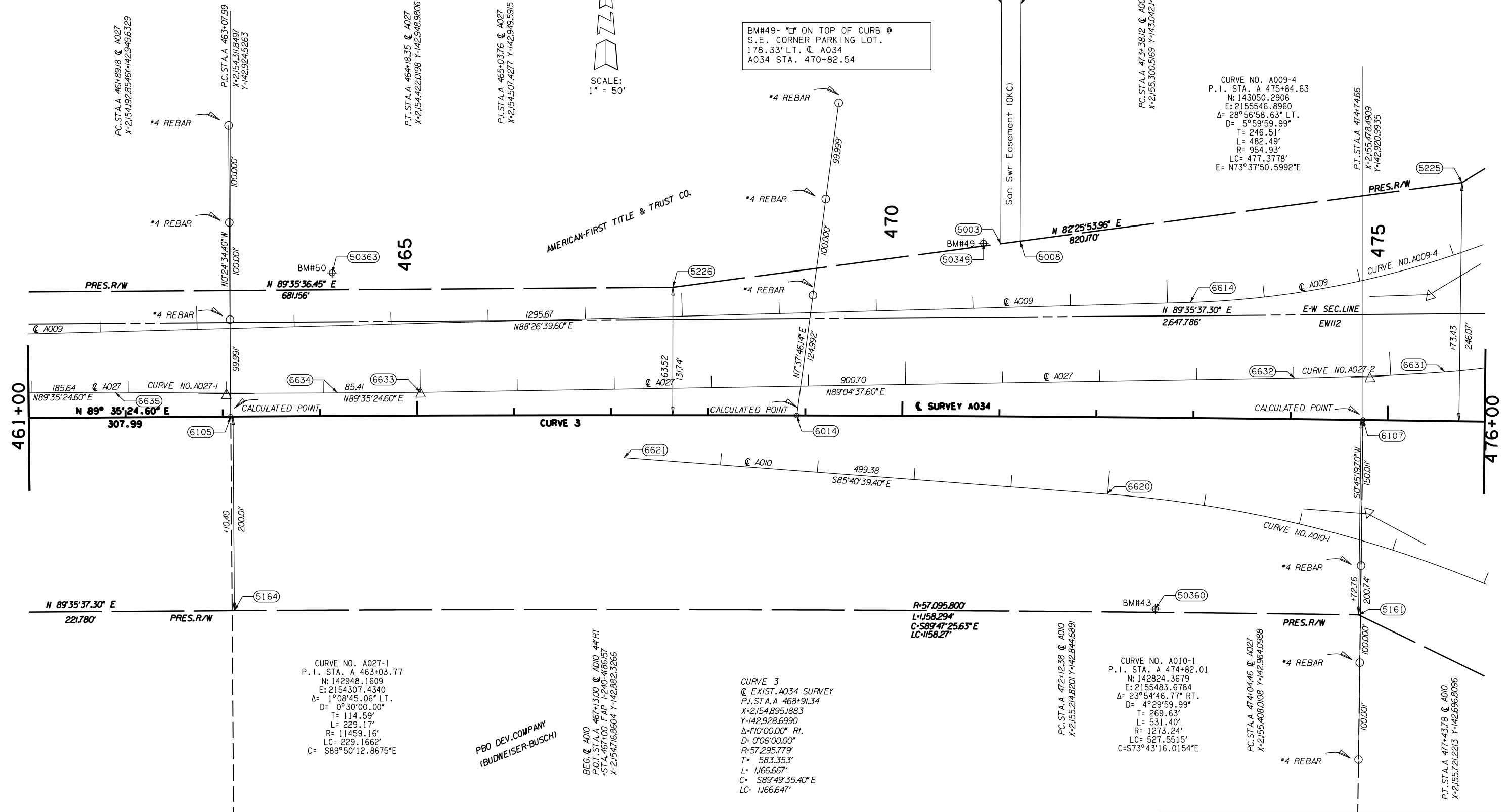

PLS				POE & ASSOCIATES, OKLAHOMA CITY, OK SURVEY DIVISION	
DRAWN				SURVEY DATA SHEET	
CHECKED					
APPROVED					
CREW	POE	SWO 2923111	PROJECT NO. 090321081		

BM#48- *X* ON SIGN BASE
WEST OF EASTERN AVE.
312.21' LT. @ A034
A034 STA. 478+91.48

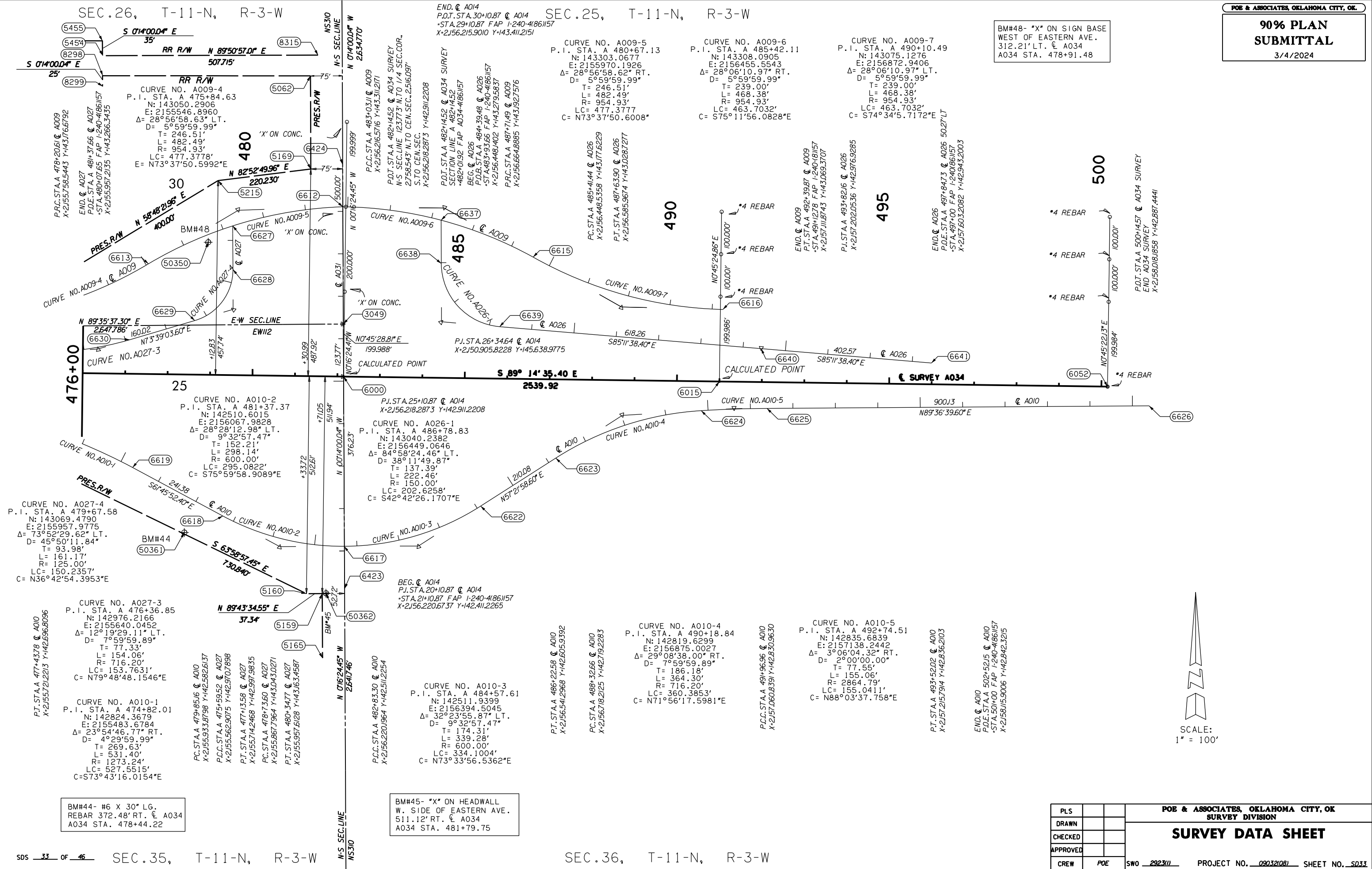

BM#48- *X* ON SIGN BASE
WEST OF EASTERN AVE.
312.21' LT. @ A034
A034 STA. 478+91.48

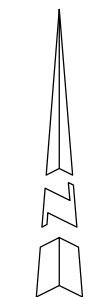

SCALE:
1" = 100'

BM#44- #6 X 30" LG.
REBAR 372.48' RT. @ A034
A034 STA. 478+44.22

BM#45- *X* ON HEADWALL
W. SIDE OF EASTERN AVE.
511.12' RT. @ A034
A034 STA. 481+79.75

PLS		POE & ASSOCIATES, OKLAHOMA CITY, OK SURVEY DIVISION SURVEY DATA SHEET
DRAWN		
CHECKED		
APPROVED		
CREW	POE	
SWO 292311		PROJECT NO. 090321081
SDS 33 OF 46		SHEET NO. 5033



SCALE:
1" = 50'

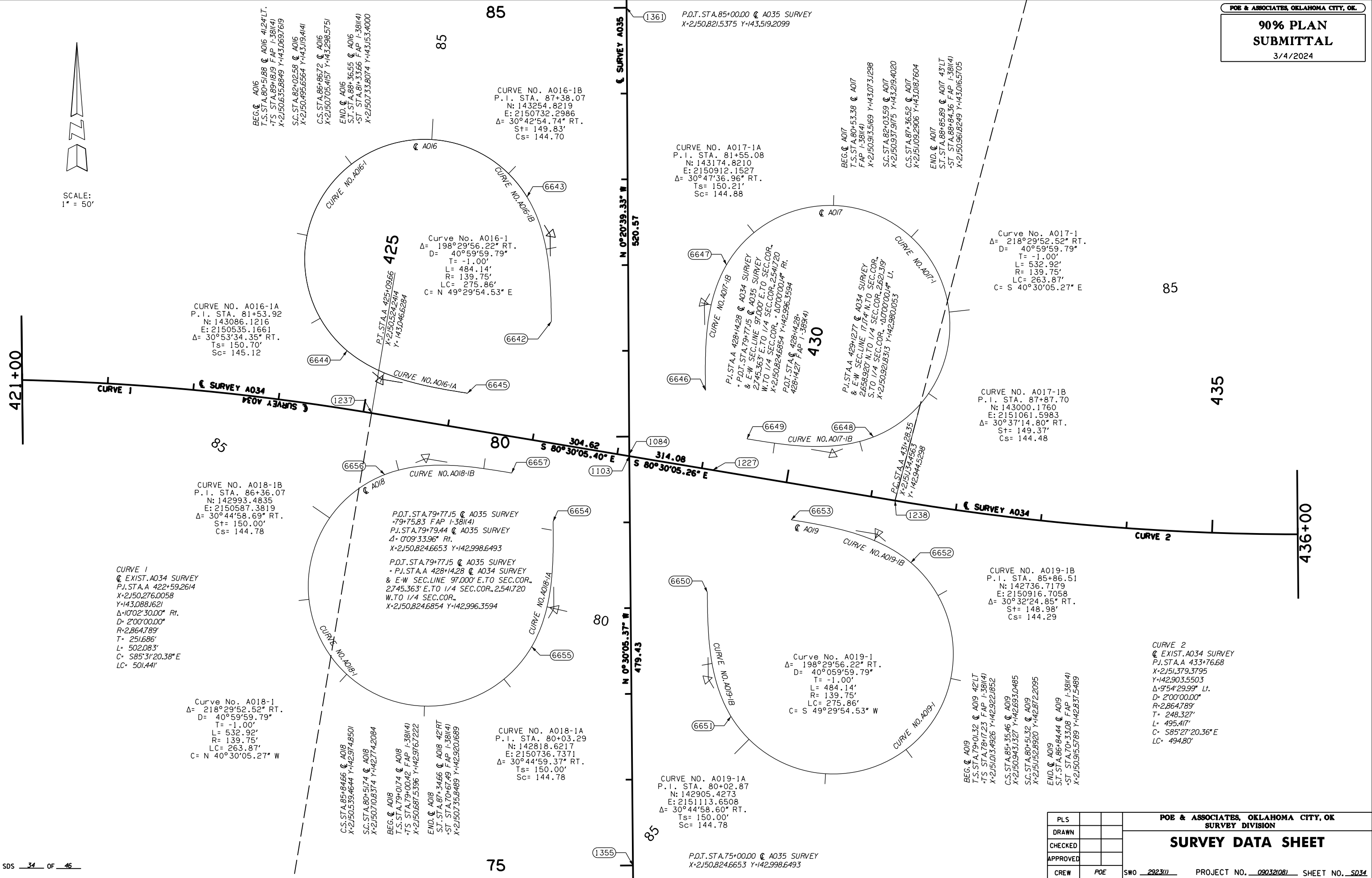

CURVE NO. A016-1A
P.I. STA. 81+53.92
N: 143086.1216
E: 2150535.1661
 $\Delta = 30^\circ 53' 34.35''$ RT.
Ts = 150.70'
Sc = 145.12

Curve No. A016-1
 $\Delta = 198^\circ 29' 56.22''$ RT.
D = $40^\circ 59' 59.79''$
T = -1.00'
L = 484.14'
R = 139.75'
LC = 275.86'
C = N $49^\circ 29' 54.53''$ E

CURVE NO. A017-1A
P.I. STA. 81+55.08
N: 143174.8210
E: 2150912.1527
 $\Delta = 30^\circ 47' 36.96''$ RT.
Ts = 150.21'
Sc = 144.88

Curve No. A017-1
 $\Delta = 218^\circ 29' 52.52''$ RT.
D = $40^\circ 59' 59.79''$
T = -1.00'
L = 532.92'
R = 139.75'
LC = 263.87'
C = S $40^\circ 30' 05.27''$ E

CURVE NO. A018-1B
P.I. STA. 86+36.07
N: 142993.4835
E: 2150587.3819
 $\Delta = 30^\circ 44' 58.69''$ RT.
Ts = 150.00'
Cs = 144.78

P.O.T. STA. 79+77.15 @ A035 SURVEY
+79+75.83 FAP I-381(4)
P.I. STA. 79+79.44 @ A035 SURVEY
 $\Delta = 0^\circ 09' 33.96''$ RT.
X=2150.8246653 Y=142.9986493

P.O.T. STA. 79+77.15 @ A035 SURVEY
= P.I. STA. A 428+14.28 @ A034 SURVEY
& E-W SEC. LINE 97.000' E. TO SEC. COR.,
2745.363' E. TO 1/4 SEC. COR., 2.541720
W. TO 1/4 SEC. COR.,
X=2150.8246854 Y=142.9963594

Curve No. A019-1
 $\Delta = 198^\circ 29' 56.22''$ RT.
D = $40^\circ 05' 59.79''$
T = -1.00'
L = 484.14'
R = 139.75'
LC = 275.86'
C = S $49^\circ 29' 54.53''$ W

CURVE NO. A019-1B
P.I. STA. 85+86.51
N: 142736.7179
E: 2150916.7058
 $\Delta = 30^\circ 32' 24.85''$ RT.
Ts = 148.98'
Cs = 144.29

Curve No. A018-1
 $\Delta = 218^\circ 29' 52.52''$ RT.
D = $40^\circ 59' 59.79''$
T = -1.00'
L = 532.92'
R = 139.75'
LC = 263.87'
C = N $40^\circ 30' 05.27''$ W

CURVE 2
@ EXIST. A034 SURVEY
P.I. STA. A 433+76.68
X=2151.3793795
Y=142.9035503
 $\Delta = 9^\circ 54' 29.99''$ Lt.
D = $2^\circ 00' 00.00''$
R = 2864.789'
T = 248.327'
L = 495.417'
C = S $85^\circ 27' 20.36''$ E
LC = 494.80'

CURVE NO. A018-1A
P.I. STA. 80+03.29
N: 142818.6217
E: 2150736.7371
 $\Delta = 30^\circ 44' 59.37''$ RT.
Ts = 150.00'
Sc = 144.78

CURVE NO. A019-1A
P.I. STA. 80+02.87
N: 142905.4273
E: 2151113.6508
 $\Delta = 30^\circ 44' 58.60''$ RT.
Ts = 150.00'
Sc = 144.78

P.O.T. STA. 75+00.00 @ A035 SURVEY
X=2150.8246653 Y=142.9986493

PLS				POE & ASSOCIATES, OKLAHOMA CITY, OK SURVEY DIVISION SURVEY DATA SHEET
DRAWN				
CHECKED				
APPROVED				
CREW	POE	SWO 2923111	PROJECT NO. 090321081 SHEET NO. 5034	

SEC.34, T-11-N, R-3-W

LOVE'S COUNTRY STORES, INC.

DALE BLISS
CLASSIC AUTO PARTS
OF OKLA, INC.



SCALE:
1" = 50'

P.O.T. STA. 25+00.00 @ A035 SURVEY
BEG. A035
X=2,150.87, Y=137,519.4210

25

*4 REBAR

*4 REBAR

*4 REBAR

*4 REBAR

1323

89TH STREET
S 89°37'41.9" W
374.937'

5480

5483

N 33°39'10.06" E
266.15'

5484

PRES. R/W N 0°25'57.7" E
300.55'

30

395.72'
S 89°37'41.9" W

5469

N 0°33'23.80" W
659.403'

2127.2'

5486

PRES. R/W N 0°25'57.7" E
327.472'

5485

+50.64
190.40'

+7.267
175.46'

+7.318
170.56'

SURVEY A035

N 0°30'05.37" W
1500.00'

34+00

+00.60
165.22'

+59.98
210.05'

+12.18
184.91'

3002

+50.01
158.96'

438.60'
PRES. R/W N 3°53'32.39" W

PRES. R/W

150.44'
N 3°53'32.39" W

5044

5049

5050

5051

N 26°13'18.39" W
57.94'

(FORD DEALERSHIP)

LINDA BROCK NELSON REV. TRUST
ARMOUR REALTY INC & DKH ENTERPRISES INC.

(STAR MANUFACTURING)
TMF II INVESTMENTS, INC.

S 89°31'48.61" W
387.000'

1258.09'
S 89°31'48.61" W

SEC.35, T-11-N, R-3-W

PLS		POE & ASSOCIATES, OKLAHOMA CITY, OK	
DRAWN		SURVEY DIVISION	
CHECKED		SURVEY DATA SHEET	
APPROVED			
CREW	POE	SWO 2923111	PROJECT NO. 09032108
			SHEET NO. 35

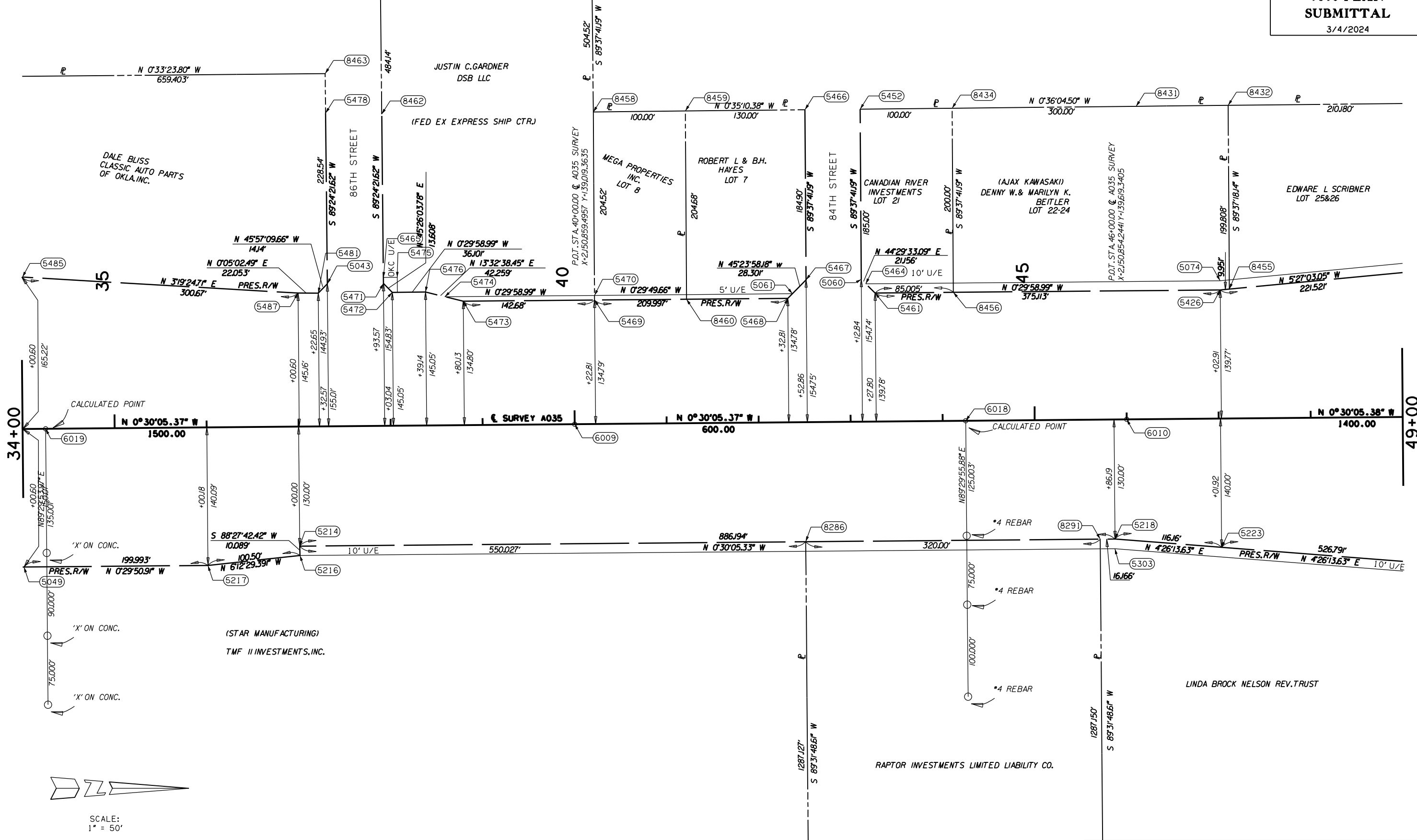

SCALE:
1" = 50'

PLS		POE & ASSOCIATES, OKLAHOMA CITY, OK	
DRAWN		SURVEY DIVISION	
CHECKED		SURVEY DATA SHEET	
APPROVED			
CREW	POE	SWO 2923111	PROJECT NO. 090321081 SHEET NO. 5036

SEC. 34, T-11-N, R-3-W

BM#30-"X" ON EAST CURB OF PARKING LOT. 154.01' LT. @ A035 A035 STA. 59+00.05

BM#33- #5 IRON ROD IN MEDIAN OF 82ND ST. (CONTROL PT. "HOSPICE") 629.22' LT @ A035 A035 STA. 53+30.60

BM#32-"X" ON CURB P.I. @ S.E. COR. OF S. PARKING LOT OF DAYS INN HOTEL 230.16' LT. @ A035 A035 STA. 53+66.62

(LA QUINTA) BRE/LO PROPERTIES LLC

P.O.T. STA. 53+38.63 @ A035 SURVEY
 E-W SEC. LINE 97.206' E TO 1/4 SEC. COR. 2739.444' E TO CEN. SEC. 2545.085' W TO CEN. SEC. X=2150.847 Y=140.357 9462
 P.I. STA. 99+02.99 @ A031
 S.T.A. 99+02.99 FAP I-1R-35-3(74)21
 X=2150.847 Y=140.357 9462
 P.O.T. STA. 53+29.93 @ A035 SURVEY
 E-W SEC. LINE 97.206' E TO 1/4 SEC. COR. 2739.444' E TO CEN. SEC. 2545.085' W TO CEN. SEC. X=2150.847 Y=140.357 9462
 P.I. STA. 99+02.99 @ A031
 S.T.A. 99+02.99 FAP I-1R-35-3(74)21
 X=2150.847 Y=140.357 9462

BEG. @ A031
 P.O.B. STA. 94+02.99 @ A031
 S.T.A. 94+02.99 FAP I-1R-35-3(74)21
 X=2150.347 Y=140.344 3985

CURVE NO. A007-1
 P.I. STA. 55+97.56
 N: 140611.9701
 E: 2150741.0631
 Δ = 30°00'00.41" LT.
 D = 229°10'59.22"
 T = 6.70'
 L = 13.09'
 R = 25.00'
 LC = 12.94'
 C = N21°15'28.63"E

CURVE NO. A007-2
 P.I. STA. 58+07.69
 N: 140821.1520
 E: 2150764.0016
 Δ = 2°36'57.99" LT.
 D = 4°00'00.00"
 T = 32.71'
 L = 65.40'
 R = 1432.39'
 LC = 65.40'
 C = N4°56'59.63"E

CURVE NO. A007-3
 P.I. STA. 63+08.98
 N: 141321.4423
 E: 2150795.8440
 Δ = 4°08'36.00" LT.
 D = 3°00'00.00"
 T = 69.09'
 L = 138.11'
 R = 1909.86'
 LC = 138.08'
 C = N1°34'12.63"E

CURVE NO. A003-7
 P.I. STA. A 444+21.61
 N: 140825.8581
 E: 2150721.6789
 Δ = 6°45'33.99" RT.
 D = 3°00'00.00"
 T = 112.79'
 L = 225.31'
 R = 1909.86'
 LC = 225.1840'
 C = S2°52'41.6019"W

SAMAY HOTEL ENTERPRISES INC. TRACT 80 (DAYS INN)

(MARSHALL PARK) M.A. & E.K. MARSHALL TRACT 79

W.RAY PELFREY REV. TRUST (DEPT. OF CORRECTIONS)

ADVANCED INVESTMENTS LLC

PRES. R/W
 N 5°27'38.46" W 339.503

PRES. R/W
 N 31°3'42.92" E 259.594

PRES. R/W
 N 3°21'06.35" E 199.17

PRES. R/W
 N 0°30'05.37" W 500.00

50

55

60

60

49+00

15

60

64+00

CL SURVEY A035

N 0°30'05.38" W 1400.00

N 0°30'05.37" W 500.00

N 0°30'05.37" W 500.00

10' U/E PRES. R/W
 N 4°26'13.63" E 526.79'

10' U/E PRES. R/W
 N 23°08'41.07" E 48.080'

N 0°30'21.50" W 2.638.493'

N 4°26'13.63" E 826.760'

N 0°30'21.50" W 2.638.493'

LINDA BROCK NELSON REV. TRUST

KWL PROPERTIES LLC.

MVP INVESTMENT LLC

MVP INVESTMENTS LLC (BLAZERS ICE CTR)

BM#34-"X" ON CURB S.W. RETURN OF S.E. SERVICE ROAD & S.E. 82ND STREET 148.34' RT. @ A035 A035 STA. 53+58.07

BM#35-"X" ON CURB E. SIDE OF MEDIAN ON 80TH STREET 348.75' RT. @ A035 A035 STA. 59+58.93

CURVE NO. A028-1
 P.I. STA. 62+45.08
 N: 141200.8776
 E: 2150962.3940
 Δ = 62°15'27.49" RT.
 D = 28°38'52.40"
 T = 120.78'
 L = 217.32'
 R = 200.00'
 LC = 206.79'
 C = S31°37'48.37"E

CURVE NO. A008-1
 P.I. STA. 64+04.37
 N: 141421.5348
 E: 2150947.4722
 Δ = 5°20'44.15" LT.
 D = 2°00'00.00"
 T = 133.74'
 L = 267.28'
 R = 2864.79'
 LC = 267.18'
 C = S2°10'16.63"W



SCALE: 1" = 50'

END. @ A031
 P.O.E. STA. 104+02.99 @ A031
 S.T.A. 104+02.99 FAP I-1R-35-3(74)21
 X=2151.347 Y=140.353 1779

SEC. 35, T-11-N, R-3-W

-STA. 104+02.99 FAP I-1R-35-3(74)21

PLS				
DRAWN				
CHECKED				
APPROVED				
CREW	POE	SWO	2923111	PROJECT NO. 090321081 SHEET NO. 5037

SURVEY DATA SHEET

SEC. 34, T-11-N, R-3-W

BM#28-*X* ON EAST CURB OF PARKING LOT. 136.00' LT. @ A035 A035 STA. 65+16.94

BM#27-*X* IN DRIVEWAY EAST OF FRONT DOOR BODYWORKS INC. 177.72' LT. @ A035 A035 STA. 68+21.51

BM#26- #6 X 30" LG. REBAR 526.25' LT. @ A035 A035 STA. 72+81.56

Curve No. A003-6
 P.I. STA. A 434+21.88
 N: 141825.8207
 E: 2150712.9264
 Δ: 5°56'11.01" RT.
 D: 2°00'00.00"
 T: 148.54'
 L: 296.82'
 R: 2864.79'
 LC: 296.6870'
 C: S3°28'10.87"E

CURVE NO. A007-5
 P.I. STA. 70+59.97
 N: 142070.7722
 E: 2150751.2824
 Δ: 5°56'14.93" RT.
 D: 4°29'59.99"
 T: 66.03'
 L: 131.94'
 R: 1273.24'
 LC: 131.89'
 C: N3°28'12.87"W

Curve No. A003-5
 P.I. Sta. A 428+69.64
 N: 142383.0775
 E: 2150650.0467
 Δ: 37°14'52.21" RT.
 D: 15°59'59.78"
 T: 120.68'
 L: 232.80'
 R: 358.10'
 LC: 228.7220'
 C: S25°03'42.87"E

CURVE NO. A007-4
 P.I. STA. 66+19.26
 N: 141631.3205
 E: 2150781.1312
 Δ: 4°17'21.02" RT.
 D: 3°00'00.00"
 T: 71.52'
 L: 142.97'
 R: 1909.86'
 LC: 142.94'
 C: N2°38'45.87"W

W.RAY PELFREY REV. TRUST (DEPT. OF CORRECTIONS)

H&H ASSOCIATES OF NORMAN LIMITED PARTNERSHIP

MID AMERICA CHRISTIAN UNIV.

MVP INVESTMENTS LLC (BLAZERS ICE CTR)

OKLA GAS & ELECT. FOUNDATION INC.

BM#37-*X* ON N. HEADWALL @ S.W. ENTR. OF O.G.&E. YARD. 865.26' RT. @ A035 A035 STA. 67+15.69

BM#38- #6 REBAR 6' W. OF O.G.&E. FENCE, 3RD LIGHT POLE FROM N. 954.34' RT. @ A035 A035 STA. 71+85.21= 693.64' RT. @ A034 STA. 437+77.03

CURVE NO. A008-1
 P.I. STA. 64+04.37
 N: 141421.5348
 E: 2150947.4722
 Δ: 5°20'44.15" LT.
 D: 2°00'00.00"
 T: 133.74'
 L: 267.28'
 R: 2864.79'
 LC: 267.18'
 C: S2°10'16.63"W

CURVE NO. A004-1
 P.I. STA. A 443+16.88
 N: 141376.5912
 E: 2151087.7076
 Δ: 23°33'28.00" LT.
 D: 7°29'59.46"
 T: 159.31'
 L: 314.11'
 R: 763.96'
 LC: 311.9021'
 C: S7°20'30.3879"E

BM#36-*X* ON S. CURB OF S.E. 79TH ST. & S.E. SERVICE ROAD 234.04' RT. @ A035 A035 STA. 66+79.07

P.T. STA. A 447+19.94 @ A004 X-2150993.4081 Y-141770.6623

P.C. STA. A 451+06.07 @ A004 X-2150990.0285 Y-142156.7775

P.L. STA. A 452+02.00 @ A008 X-21509540399 Y-142156.4624

P.C. STA. A 472+27.02 @ A008 X-2150963.3835 Y-142231.4596

CURVE NO. A008-2
 P.I. STA. 73+75.59
 N: 142380.0152
 E: 2150955.7160
 Δ: 47°02'30.05" RT.
 D: 16°47'04.95"
 T: 148.57'
 L: 280.27'
 R: 341.36'
 LC: 272.46'
 C: N24°25'13.33"E

CURVE NO. A004-3
 P.I. STA. A 453+05.57
 N: 142356.2692
 E: 2150988.2824
 Δ: 47°02'27.11" RT.
 D: 12°29'59.63"
 T: 199.50'
 L: 376.33'
 R: 458.37'
 LC: 365.8490'
 C: S23°1'08.1847"W

P.T. STA. A 75+07.28 @ A008 X-2151066.0258 Y-142473.5438

P.T. STA. A 454+82.40 @ A004 X-2151533.0884 Y-142495.4960

P.L. STA. A 75+82.28 @ A008 X-2151020.4651 Y-142531.322

P.C. STA. A 77+42.50 @ A008 X-2151236.7619 Y-142641.3389

P.C. STA. A 457+09.27 @ A004 X-2151297.7635 Y-142649.5476

PLS	
DRAWN	
CHECKED	
APPROVED	
CREW	POE

POE & ASSOCIATES, OKLAHOMA CITY, OK SURVEY DIVISION

SURVEY DATA SHEET

SWO 292311 PROJECT NO. 090321081 SHEET NO. 5038

SEC. 35, T-11-N, R-3-W

SCALE: 1" = 50'

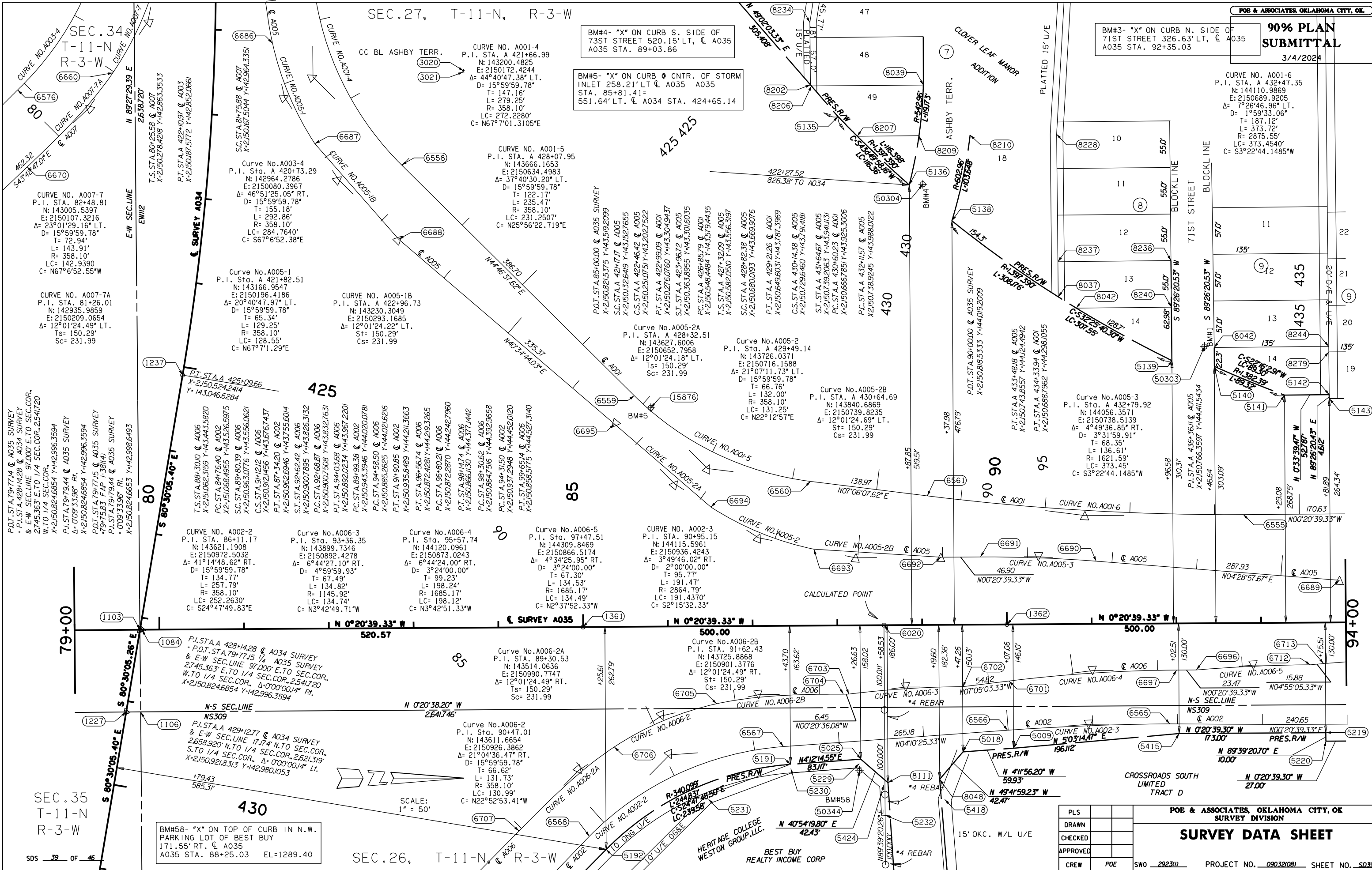

BM#3- "X" ON CURB N. SIDE OF 71ST STREET 326.63' LT. @ A035 A035 STA. 92+35.03

BM#4- "X" ON CURB S. SIDE OF 73ST STREET 520.15' LT. @ A035 A035 STA. 89+03.86

BM#5- "X" ON CURB @ CNTR. OF STORM INLET 258.21' LT @ A035 A035 STA. 85+81.41= 551.64' LT. @ A034 STA. 424+65.14

CURVE NO. A001-6
 P.I. STA. A 432+47.35
 N: 144110.9869
 E: 2150689.9205
 Δ: 7°26'46.96" RT.
 D: 1°59'33.06"
 T: 187.12'
 L: 373.72'
 R: 2875.55'
 LC: 373.4540'
 C: S3°22'44.1485"W

Curve No. A003-4
 P.I. Sta. A 420+73.29
 N: 142964.2786
 E: 2150080.3967
 Δ: 46°51'25.05" RT.
 D: 15°59'59.78"
 T: 155.18'
 L: 292.86'
 R: 358.10'
 LC: 284.7640'
 C: S67°06'52.38"E

Curve No. A005-1
 P.I. Sta. A 421+82.51
 N: 143166.9547
 E: 2150196.4186
 Δ: 20°40'47.97" LT.
 D: 15°59'59.78"
 T: 65.34'
 L: 129.25'
 R: 358.10'
 LC: 128.55'
 C: N67°07'1.29"E

Curve No. A002-2
 P.I. Sta. 86+11.17
 N: 143621.1908
 E: 2150972.5032
 Δ: 41°14'48.62" RT.
 D: 15°59'59.78"
 T: 134.77'
 L: 257.79'
 R: 358.10'
 LC: 252.2630'
 C: S24°47'49.83"E

Curve No. A006-3
 P.I. Sta. 93+36.35
 N: 143899.7346
 E: 2150892.4278
 Δ: 6°44'27.10" RT.
 D: 4°59'59.93"
 T: 67.49'
 L: 134.82'
 R: 1145.92'
 LC: 134.74'
 C: N3°42'49.71"W

Curve No. A006-2A
 P.I. Sta. 89+30.53
 N: 143514.0636
 E: 2150990.7747
 Δ: 12°01'24.49" RT.
 D: 15°59'59.78"
 T: 66.62'
 L: 131.73'
 R: 358.10'
 LC: 130.99'
 C: N22°52'53.41"W

Curve No. A006-2
 P.I. Sta. 90+47.01
 N: 143611.6654
 E: 2150926.3862
 Δ: 21°04'36.47" RT.
 D: 15°59'59.78"
 T: 66.62'
 L: 131.73'
 R: 358.10'
 LC: 130.99'
 C: N22°52'53.41"W

BM#58- "X" ON TOP OF CURB IN N.W. PARKING LOT OF BEST BUY 171.55' RT. @ A035 A035 STA. 88+25.03 EL=1289.40

PLS		POE & ASSOCIATES, OKLAHOMA CITY, OK
DRAWN		SURVEY DIVISION
CHECKED		SURVEY DATA SHEET
APPROVED		
CREW	POE	SWO 292311 PROJECT NO. 090321081 SHEET NO. 5039

90% PLAN SUBMITTAL

Curve No. A032-1
P.I. Sta. 108+56.33
N: 145872.2159
E: 2150707.4017
Δ = 26°21'31.33" LT.
D = 229°10'59.22"
T = 5.85'
L = 11.50'
R = 25.00'
LC = 11.4'
C = S16°28'33.17"W

P.T. STA. 108+61.98 @ A032
X-2150707.383 Y+145878.0604

Curve No. A032-2
P.I. Sta. 108+56.33
N: 145872.2159
E: 2150707.4017
Δ = 26°21'31.33" LT.
D = 229°10'59.22"
T = 5.85'
L = 11.50'
R = 25.00'
LC = 11.4'
C = S16°28'33.17"W

P.T. STA. 108+61.98 @ A032
X-2150707.383 Y+145878.0604

Curve No. A032-3
P.I. Sta. 108+56.33
N: 145872.2159
E: 2150707.4017
Δ = 26°21'31.33" LT.
D = 229°10'59.22"
T = 5.85'
L = 11.50'
R = 25.00'
LC = 11.4'
C = S16°28'33.17"W

P.T. STA. 108+61.98 @ A032
X-2150707.383 Y+145878.0604

Curve No. A032-4
P.I. Sta. 108+56.33
N: 145872.2159
E: 2150707.4017
Δ = 26°21'31.33" LT.
D = 229°10'59.22"
T = 5.85'
L = 11.50'
R = 25.00'
LC = 11.4'
C = S16°28'33.17"W

P.T. STA. 108+61.98 @ A032
X-2150707.383 Y+145878.0604

Curve No. A032-5
P.I. Sta. 108+56.33
N: 145872.2159
E: 2150707.4017
Δ = 26°21'31.33" LT.
D = 229°10'59.22"
T = 5.85'
L = 11.50'
R = 25.00'
LC = 11.4'
C = S16°28'33.17"W

P.T. STA. 108+61.98 @ A032
X-2150707.383 Y+145878.0604

Curve No. A032-6
P.I. Sta. 108+56.33
N: 145872.2159
E: 2150707.4017
Δ = 26°21'31.33" LT.
D = 229°10'59.22"
T = 5.85'
L = 11.50'
R = 25.00'
LC = 11.4'
C = S16°28'33.17"W

P.T. STA. 108+61.98 @ A032
X-2150707.383 Y+145878.0604

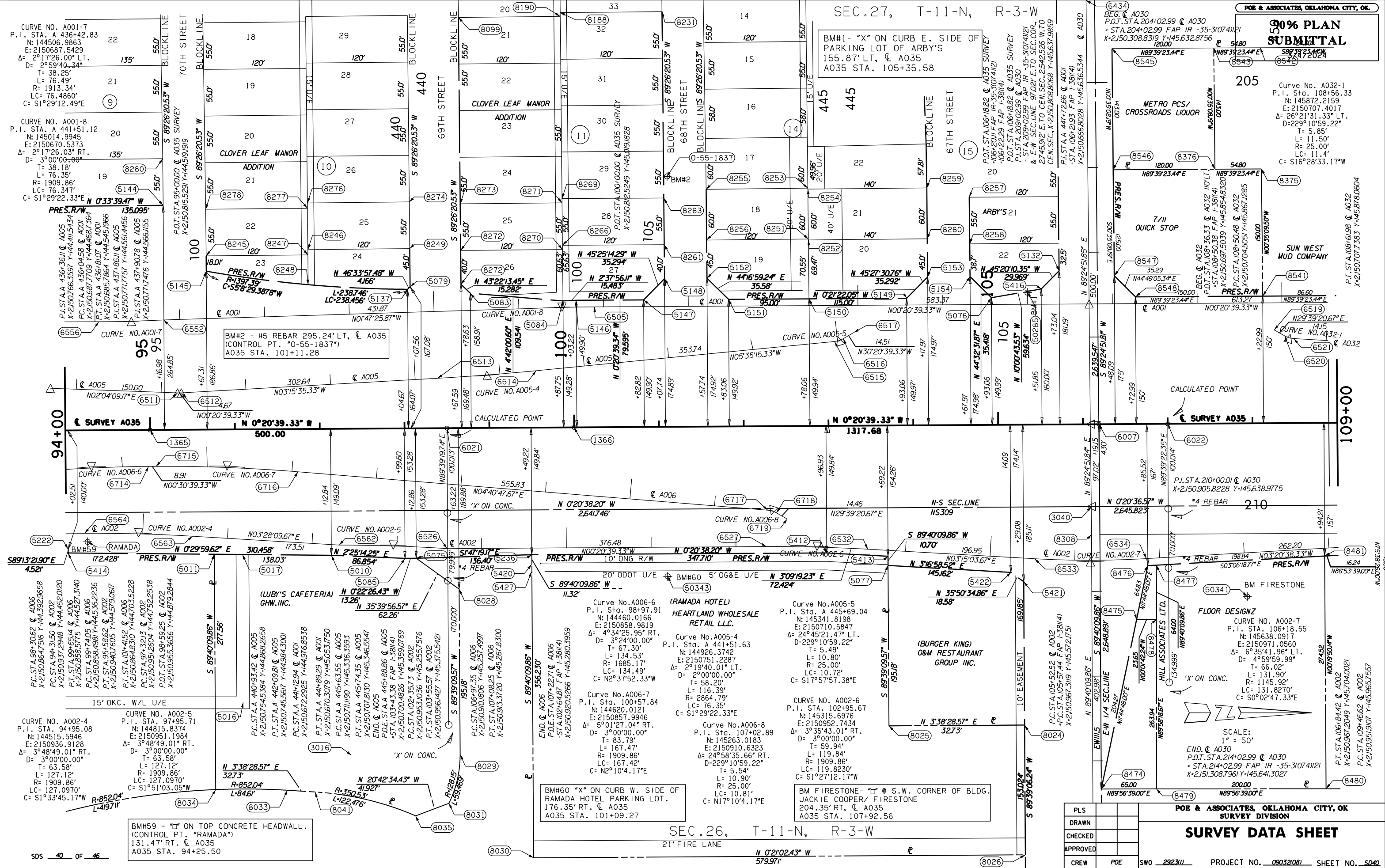

PLS	
DRAWN	
CHECKED	
APPROVED	
CREW	POE SWO 2923111

POE & ASSOCIATES, OKLAHOMA CITY, OK
SURVEY DIVISION

SURVEY DATA SHEET

PROJECT NO. 090321081 SHEET NO. SD40
OKLAHOMA COUNTY

SCALE: 1" = 50'

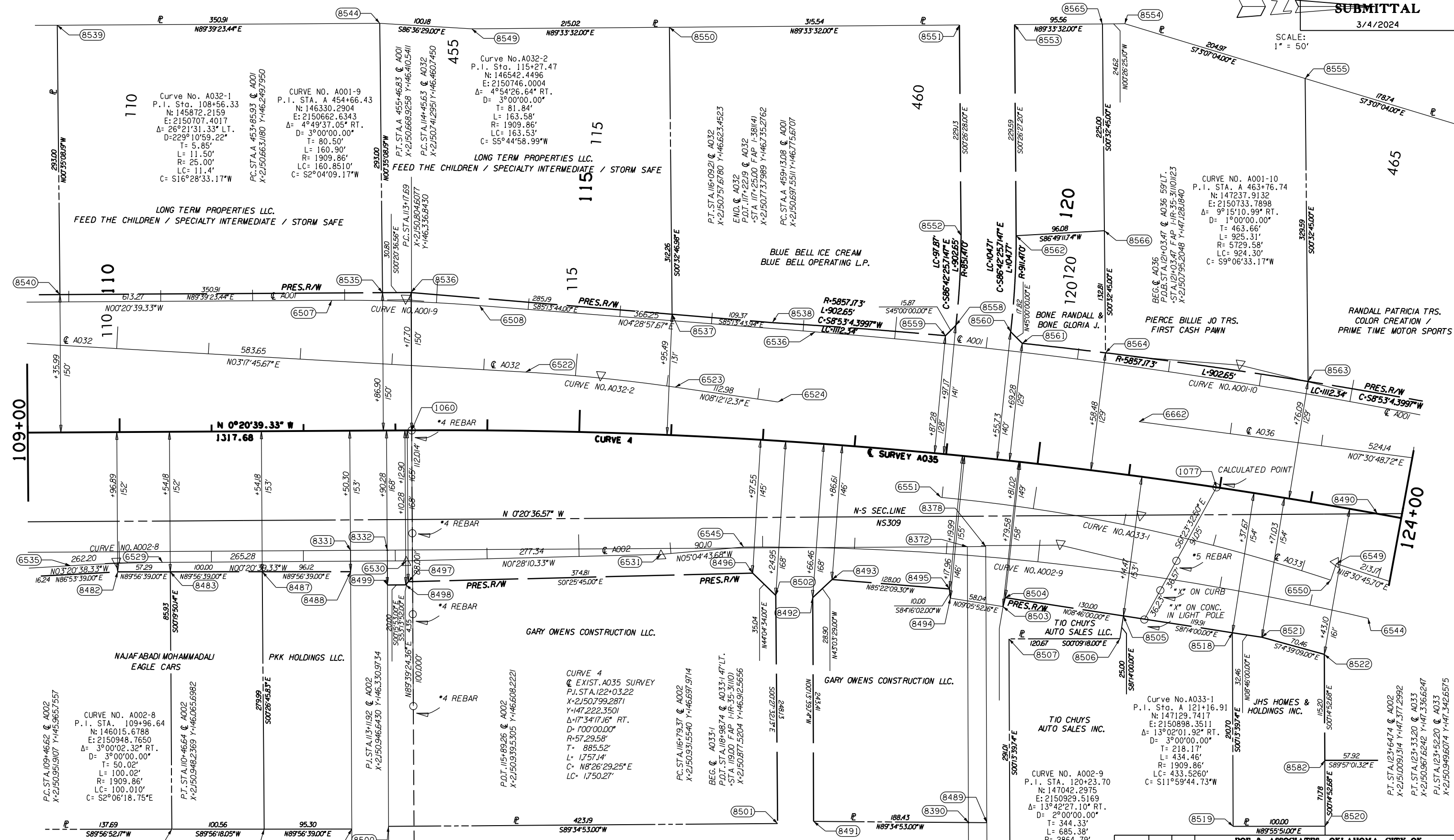

PLS				
DRAWN				
CHECKED				
APPROVED				
CREW	POE	SWO	2923111	

POE & ASSOCIATES, OKLAHOMA CITY, OK
SURVEY DIVISION

SURVEY DATA SHEET

PROJECT NO. 090321081 SHEET NO. 5041
OKLAHOMA COUNTY

SEC. 27, T-11-N, R-3-W

SEC. 26, T-11-N, R-3-W

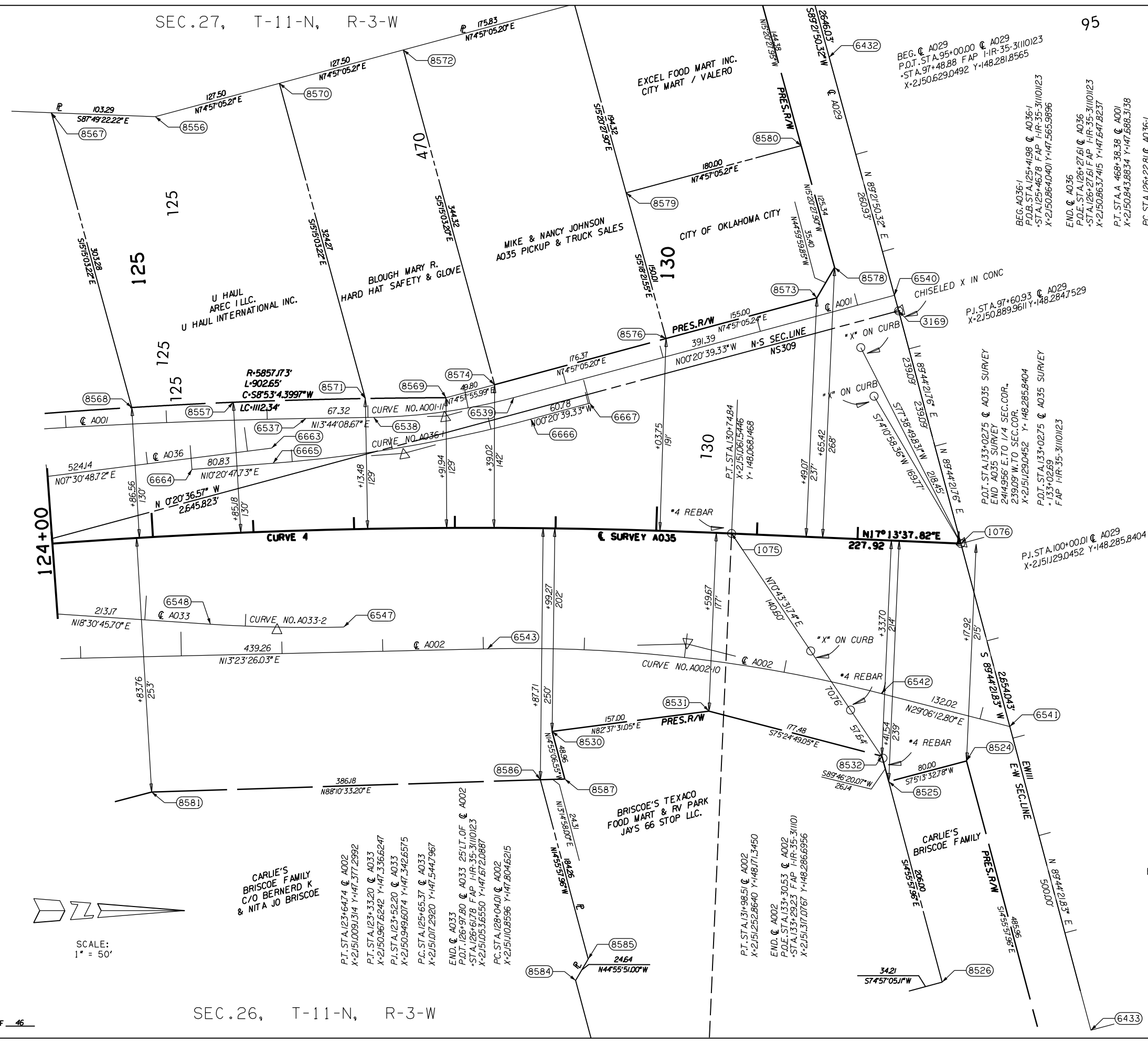

95

100

105

BEG. @ A029
 P.O.T. STA. 95+00.00 @ A029
 *STA. 97+48.88 FAP I-IR-35-3(10)123
 X-2150.629,0492 Y-148.281,8565

BEG. @ A036-1
 P.O.B. STA. 125+41.98 @ A036-1
 *STA. 125+46.78 FAP I-IR-35-3(10)123
 X-2150.864,0401 Y-147.565,9896

END. @ A036
 P.O.E. STA. 126+27.61 @ A036
 *STA. 126+27.61 FAP I-IR-35-3(10)123
 X-2150.863,7415 Y-147.647,8237

P.T. STA. A. 468+38.38 @ A001
 X-2150.843,8834 Y-147.688,5138

PC. STA. 126+22.81 @ A036-1
 X-2150.878,5574 Y-147.645,5052

PC. STA. A. 469+05.70 @ A001
 X-2150.859,8681 Y-147.537,085

P.T. STA. A. 470+46.50 @ A001
 X-2150.876,2437 Y-147.853,9966

P.T. STA. 128+82.68 @ A036-1
 X-2150.901,1789 Y-147.504,0104

END. @ A036-1
 P.O.E. STA. 129+43.46 @ A036-1 25 RT. OF @ A001
 *STA. 129+48.26 FAP I-IR-35-3(10)123
 X-2150.900,8138 Y-147.964,7893

END. @ A001
 P.O.E. STA. A. 474+37.89 @ A001
 *STA. 132+81.04 FAP I-IR-35-3(10)1
 X-2150.873,8921 Y-148.284,5745

CURVE NO. A001-11
 P.I. STA. A 469+76.46
 N: 147822.4414
 E: 2150876.6688
 Δ: 14°04'47.99" LT.
 D: 9°59'59.99"
 T: 70.76'
 L: 140.80'
 R: 572.96'
 LC: 140.446'
 C: S6°41'44.67"W

CURVE NO. A036-1-1
 P.I. STA. 127+53.12
 N: 147773.6995
 E: 2150901.9619
 Δ: 10°41'27.07" LT.
 D: 4°06'50.13"
 T: 130.31'
 L: 259.87'
 R: 1392.73'
 LC: 259.49'
 C: N5°0'4.205"E

CURVE 4
 @ EXIST. A035 SURVEY
 P.I. STA. 122+03.22
 X-2150.799,2871
 Y-147.222,3501
 Δ: 17°34'17.16" RT.
 D: 100°00.00"
 R: 57.2958'
 T: 885.52'
 L: 1757.14'
 C: N8°26'29.25"E
 LC: 1750.27'

Curve No. A033-2
 P.I. Sta. 126+31.63
 N: 147607.6266
 E: 2151038.3301
 Δ: 5°08'22.89" LT.
 D: 3°52'52.00"
 T: 66.26'
 L: 132.43'
 R: 1476.27'
 LC: 132.3840'
 C: S15°56'34.26"W

CURVE NO. A002-10
 P.I. STA. 130+02.52
 N: 147997.8231
 E: 2151156.4506
 Δ: 15°46'48.47" RT.
 D: 4°00'00.00"
 T: 198.51'
 L: 394.50'
 R: 1432.39'
 LC: 393.2575'
 C: S21°10'03.5045"W

END. @ A029
 P.O.T. STA. 105+00.01 @ A029
 *STA. 101+88.00 FAP I-IR-35-3(10)123
 X-2151.629,0400 Y-148.288,1146

P.T. STA. 123+64.74 @ A002
 X-2151.009,1314 Y-147.377,2992

P.T. STA. 123+33.20 @ A033
 X-2150.967,6242 Y-147.336,6247

P.I. STA. 123+52.20 @ A033
 X-2150.949,6074 Y-147.342,6575

P.C. STA. 125+65.37 @ A033
 X-2151.017,2920 Y-147.544,7967

END. @ A033
 P.O.T. 126+97.80 @ A033 25 RT. OF @ A002
 *STA. 126+61.78 FAP I-IR-35-3(10)123
 X-2151.053,6550 Y-147.672,0887

PC. STA. 128+04.01 @ A002
 X-2151.010,8596 Y-147.804,6215

P.T. STA. 131+98.51 @ A002
 X-2151.252,8640 Y-148.171,3450

END. @ A002
 P.O.E. STA. 133+30.53 @ A002
 *STA. 133+29.23 FAP I-IR-35-3(10)1
 X-2151.317,0767 Y-148.286,6956



SCALE:
 1" = 50'

PLS		POE & ASSOCIATES, OKLAHOMA CITY, OK	
DRAWN		SURVEY DIVISION	
CHECKED		SURVEY DATA SHEET	
APPROVED			
CREW			
POE	SWO	2923111	PROJECT NO. 090321081 SHEET NO. SD42

90% PLAN
SUBMITTAL

3/4/2024

SECTION CORNER
ODOT# 0-55-97
SET SANDSTONE 14 X 12 X 3
G.L.O. NOTES APPROVED 09-23-1873
OKLAHOMA CERTIFIED CORNER RECORD DATED 07-30-2002
FOUND CHISELED X IN CONC
X=2150889.9611 Y= 148284.7529

1/4 SECTION CORNER
ODOT# 0-55-1368
SET 14 X 10 X 4 SANDSTONE
GLO NOTES APPROVED 09-23-1873
OKLAHOMA CERTIFIED CORNER RECORD 01-13-1997
FOUND PK NAIL
X=21456619.0344 Y= 145578.6212

CENTER 1/4 SECTION CORNER
ODOT# 0-55-1314
OKLAHOMA CERTIFIED CORNER RECORD 07-30-2002
FOUND PK NAIL
X=2148266.4141 Y= 145611.9997

1/4 SECTION CORNER
ODOT# 0-55-99
SET SANDSTONE 15 X 13 X 4
G.L.O. NOTES APPROVED 09-23-1873
OKLAHOMA CERTIFIED CORNER RECORD 07-30-2002
SET CHISELED X IN PAVEMENT FROM EXISTING REFERENCE POINTS
X=2150905.8228 Y= 145638.9775

SECTION CORNER
ODOT# 0-55-634
SET 16 X 12 X 5 SANDSTONE
FOUND 1/2" IRON PIN
X=2150921.6810 Y= 142997.2789

SECTION CORNER
ODOT# 0-55-1367
SET 16 X 12 X 3 SANDSTONE
G.L.O. NOTES APPROVED 09-23-1873
OKLAHOMA CERTIFIED CORNER RECORD 02-12-1985
FOUND 1/2" I.P.
X=2145642.3196 Y= 142947.5057

1/4 SECTION CORNER
ODOT# 0-55-1313
SET 14 X 12 X 3 SANDSTONE
OKLAHOMA CERTIFIED CORNER RECORD 03-22-2006
FOUND PK NAIL
X=2148283.0793 Y= 142972.3253

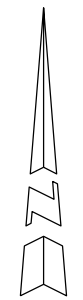
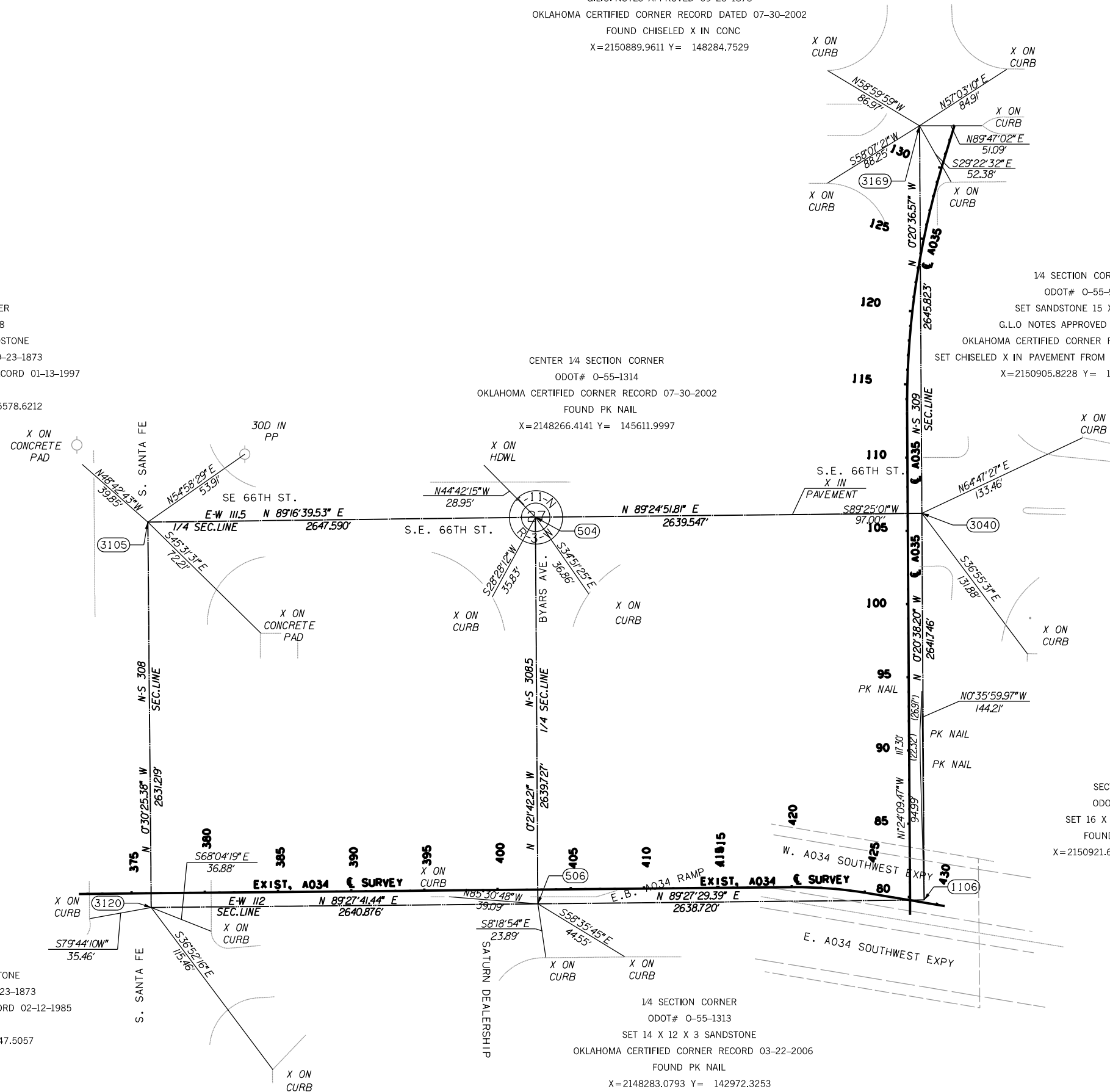

SCALE:
1" = 400'

NOTE: REFERENCE'S SHOWN ARE NOT TO SCALE.

PLS		POE & ASSOCIATES, OKLAHOMA CITY, OK	
DRAWN		SURVEY DIVISION	
CHECKED		SURVEY DATA SHEET	
APPROVED			
CREW	POE	SWO 2923111	PROJECT NO. 090321081 SHEET NO. 5043

**90% PLAN
SUBMITTAL**
3/4/2024

SECTION CORNER
 ODOT# 0-55-1367
 SET 16 X 12 X 3 SANDSTONE
 G.L.O. NOTES APPROVED 09-23-1873
 OKLAHOMA CERTIFIED CORNER RECORD 02-12-1985
 FOUND 1/2" I.P.
 X=2145642.3196 Y= 142947.5057

1/4 SECTION CORNER
 ODOT# 0-55-1313
 SET 14 X 12 X 3 SANDSTONE
 OKLAHOMA CERTIFIED CORNER RECORD 03-22-2006
 FOUND PK NAIL
 X=2148283.0793 Y= 142972.3253

SECTION CORNER
 ODOT# 0-55-634
 SET 16 X 12 X 5 SANDSTONE
 FOUND 1/2" IRON PIN
 X=2150921.6810 Y= 142997.2789

1/4 SECTION CORNER
 ODOT# 0-55-633
 SET SANDSTONE 18 X 10 X 5
 G.L.O. NOTES 09-23-1873
 FOUND CHISELED X
 X=2150944.9809 Y= 140358.8887

1/4 SECTION CORNER
 ODOT# 0-55-1366
 SET SANDSTONE 14 X 12 X 4
 G.L.O. NOTES 09-23-1873
 OKLAHOMA CERTIFIED CORNER RECORD 02-12-1985
 FOUND 3/8" IP
 X=2145664.2927 Y= 140307.6692

CERNER 1/4 SECTION CORNER
 ODOT# 0-55-1312
 OKLAHOMA CERTIFIED CORNER
 RECORD 03-22-2006
 FOUND 1/2" I.P.
 X=2148302.8137 Y= 140333.2689

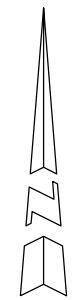
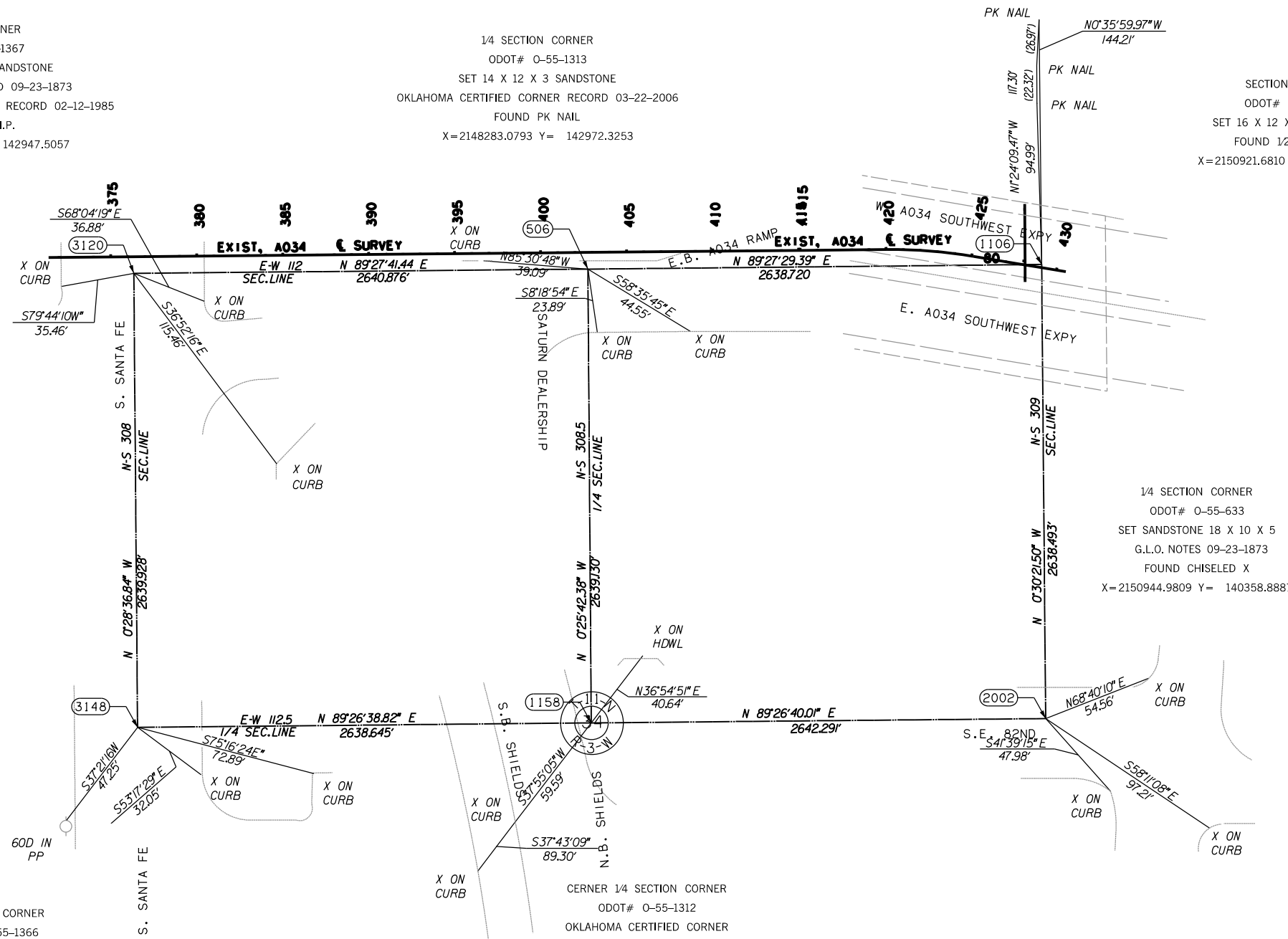

SCALE:
1" = 400'

NOTE: REFERENCE'S SHOWN ARE NOT TO SCALE.

PLS		POE & ASSOCIATES, OKLAHOMA CITY, OK	
DRAWN		SURVEY DIVISION	
CHECKED		SURVEY DATA SHEET	
APPROVED			
CREW	POE	SWO 292311	PROJECT NO. 090321081 SHEET NO. 5044

**90% PLAN
SUBMITTAL**

3/4/2024

SECTION CORNER
ODOT# 0-55-634
SET 16 X 12 X 5 SANDSTONE
FOUND 12" IRON PIN
X=2150921.6810 Y= 142997.2789

1/4 SECTION CORNER
ODOT# 0-55-627
SET SANDSTONE 14 X 12 X 3
G.L.O. NOTES APPROVED 09-23-1873
OKLAHOMA CERTIFIED CORNER RECORD 07-30-2002
FOUND ODOT BRASS CAP MON. NO. 0-55-100
X=2153569.9771 Y= 143016.2160

SECTION CORNER
ODOT# 0-55-628
SET 18 X 15 X 3 FOR CORNER
G.L.O. NOTES DATED 09-23-1873
OKLAHOMA CERTIFIED CORNER RECORD 02-12-2001
FOUND 12" I.P.
X=2156217.6966 Y= 143034.9922

1/4 SECTION CORNER
ODOT# 0-55-633
SET SANDSTONE 18 X 10 X 5
G.L.O. NOTES 09-23-1873
FOUND CHISELED X
X=2150944.9809 Y= 140358.8887

CENTER 1/4 SECTION CORNER
ODOT# 0-55-635
OKLAHOMA CERTIFIED CORNER RECORD 07-30-2002
FOUND 38" I.P.
X=2153587.1457 Y= 140378.4950

1/4 SECTION CORNER
ODOT# 0-55-629
SET SANDSTONE 18 X 10 X 3
G.L.O. NOTES 09-23-1873
OKLAHOMA CERTIFIED CORNER RECORD 02-12-1985
FOUND PK NAIL WITH SHINER
X=2156230.2960 Y= 140395.1520

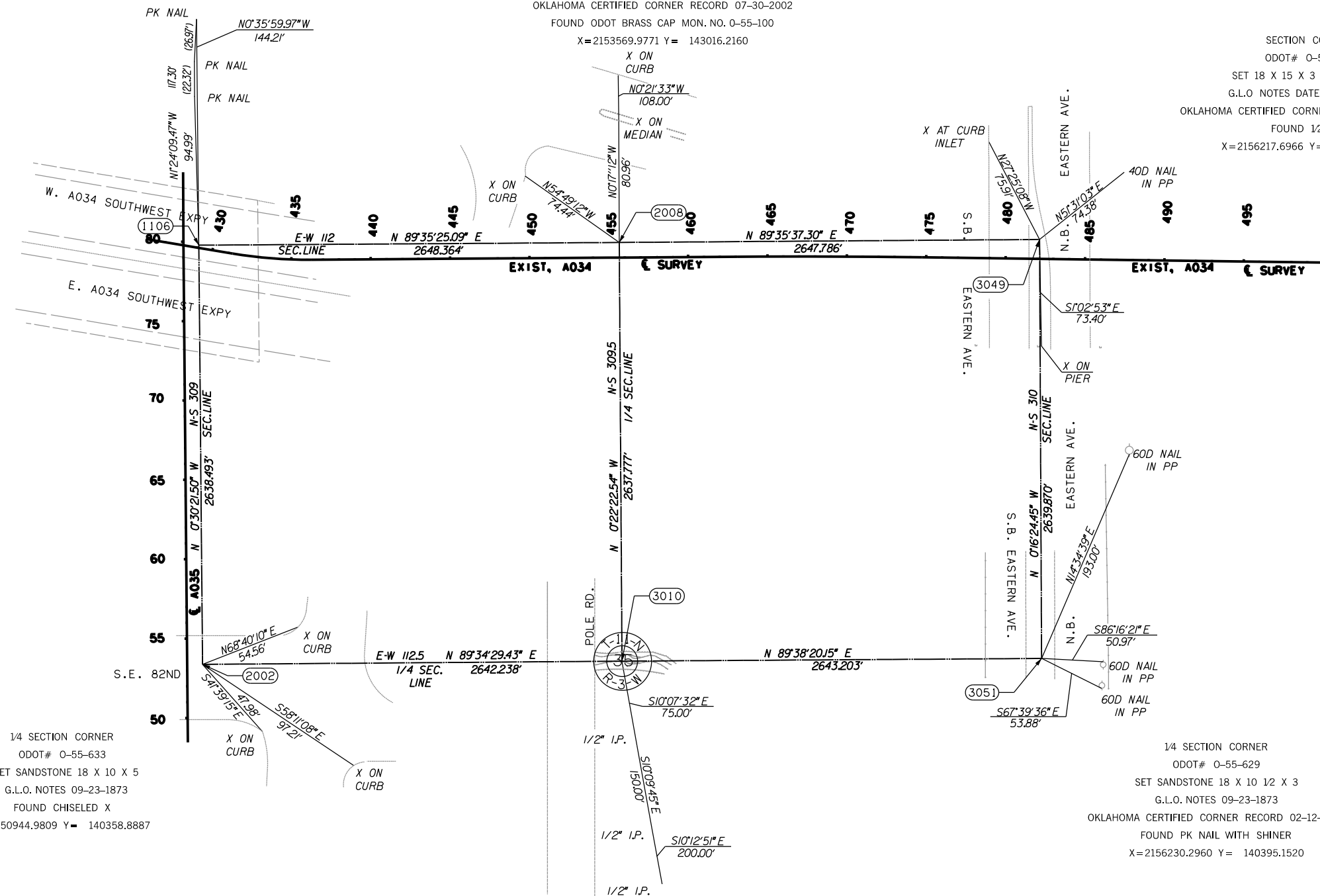

SCALE:
1" = 400'

NOTE: REFERENCE'S SHOWN ARE NOT TO SCALE.

PLS		POE & ASSOCIATES, OKLAHOMA CITY, OK	
DRAWN		SURVEY DIVISION	
CHECKED		SURVEY DATA SHEET	
APPROVED			
CREW	POE	SWO 292311	PROJECT NO. 090321081 SHEET NO. 5045

SECTION CORNER
ODOT# 0-55-97
SET SANDSTONE 14 X 12 X 3
G.L.O. NOTES APPROVED 09-23-1873
OKLAHOMA CERTIFIED CORNER RECORD DATED 07-30-2002
FOUND CHISELED X IN CONC
X=2150889.9611 Y= 148284.7529

1/4 SECTION CORNER
ODOT# 0-55-98
SET SANDSTONE 14 X 10 X 5
G.L.O. NOTES APPROVED 09-23-1873
OKLAHOMA CERTIFIED CORNER RECORD
DATED 08-30-2002
FOUND PK NAIL
X=2153543.9765 Y= 148296.8244

1/4 SECTION CORNER
ODOT# 0-55-99
SET SANDSTONE 15 X 13 X 4
G.L.O. NOTES APPROVED 09-23-1873
OKLAHOMA CERTIFIED CORNER RECORD 07-30-2002
SET CHISELED X IN PAVEMENT FROM EXISTING REFERENCE POINTS
X=2150905.8228 Y= 145638.9775

CENTER 1/4 SECTION CORNER
ODOT# 0-55-1315
OKLAHOMA CERTIFIED CORNER RECORD 07-30-2002
FOUND IRON PIN UNDER CHAINLINK FENCE
X=2153554.6702 Y= 145654.2614

1/4 SECTION CORNER
ODOT# 0-55-1767
SET SANDSTONE 20 X 16 X 3
G.L.O. NOTES APPROVED 09-23-1873
FOUND CHISELED X IN PAVEMENT
X=2156206.9662 Y= 145669.7401

SECTION CORNER
ODOT# 0-55-634
SET 16 X 12 X 5 SANDSTONE
FOUND 1/2" IRON PIN
X=2150921.6810 Y= 142997.2789

SECTION CORNER
ODOT# 0-55-628
SET 18 X 15 X 3 FOR CORNER
G.L.O. NOTES DATED 09-23-1873
OKLAHOMA CERTIFIED CORNER RECORD 02-12-2001
FOUND 1/2" I.P.
X=2156217.6966 Y= 143034.9922

1/4 SECTION CORNER
ODOT# 0-55-627
SET SANDSTONE 14 X 12 X 3
G.L.O. NOTES APPROVED 09-23-1873
OKLAHOMA CERTIFIED CORNER RECORD 07-30-2002.
FOUND ODOT BRASS CAP MON. NO. 0-55-100
X=2153569.9771 Y= 143016.2160

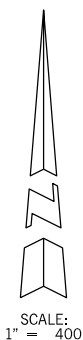
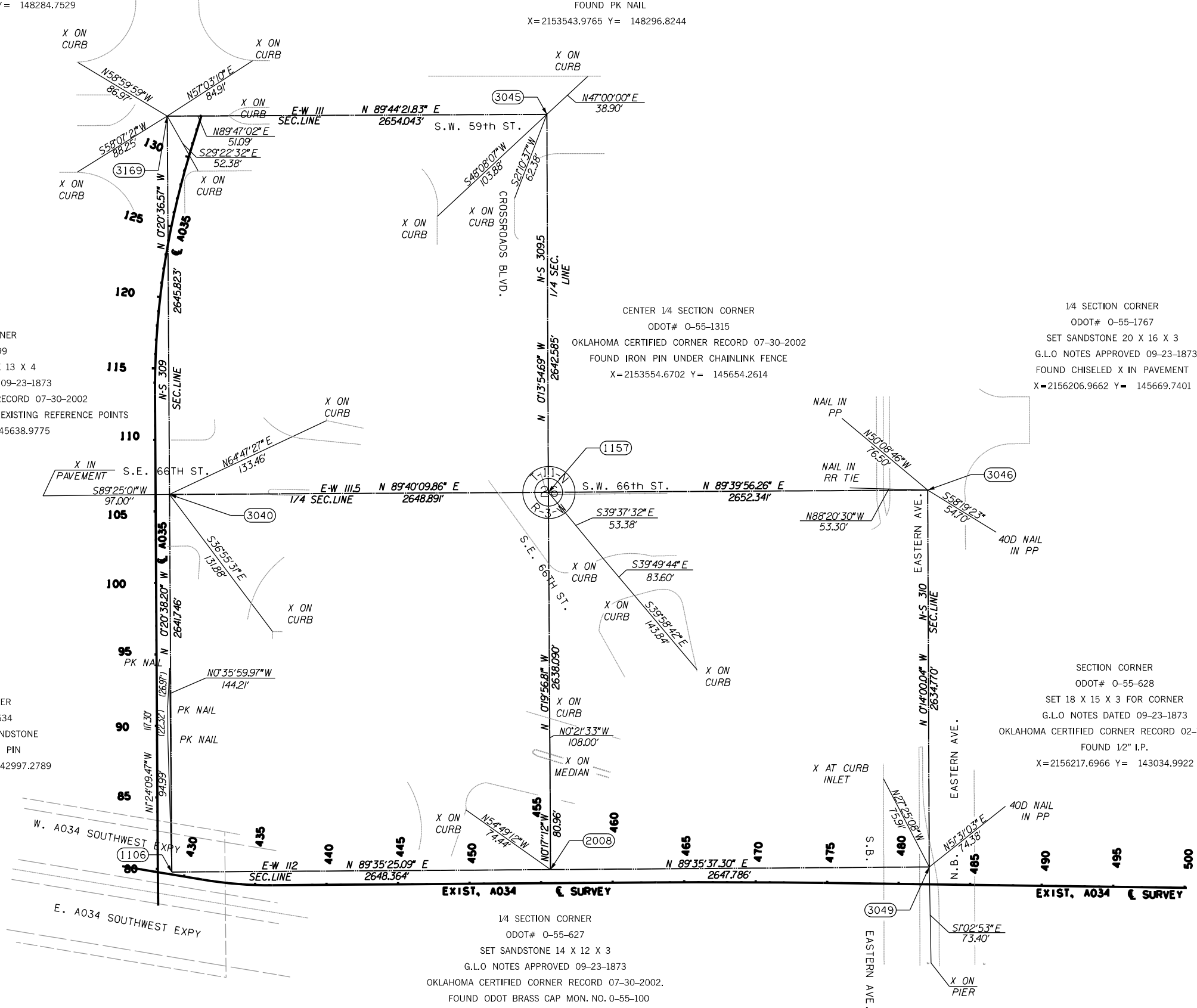

NOTE: REFERENCE'S SHOWN ARE NOT TO SCALE.

PLS		POE & ASSOCIATES, OKLAHOMA CITY, OK	
DRAWN		SURVEY DIVISION	
CHECKED		SURVEY DATA SHEET	
APPROVED			
CREW	POE		
		SWO 2923111	PROJECT NO. 090321081 SHEET NO. 5046

2/27/2024 12:22:48 PM
 H:\PROJECTS\2789_CrossRoads_Phase 4\Roadway\Working\Trace\Phase 4\2024 Update\PHI SHEETS\0903208-TRAFFIC CONTROL I-240 PHI SHI.dgn

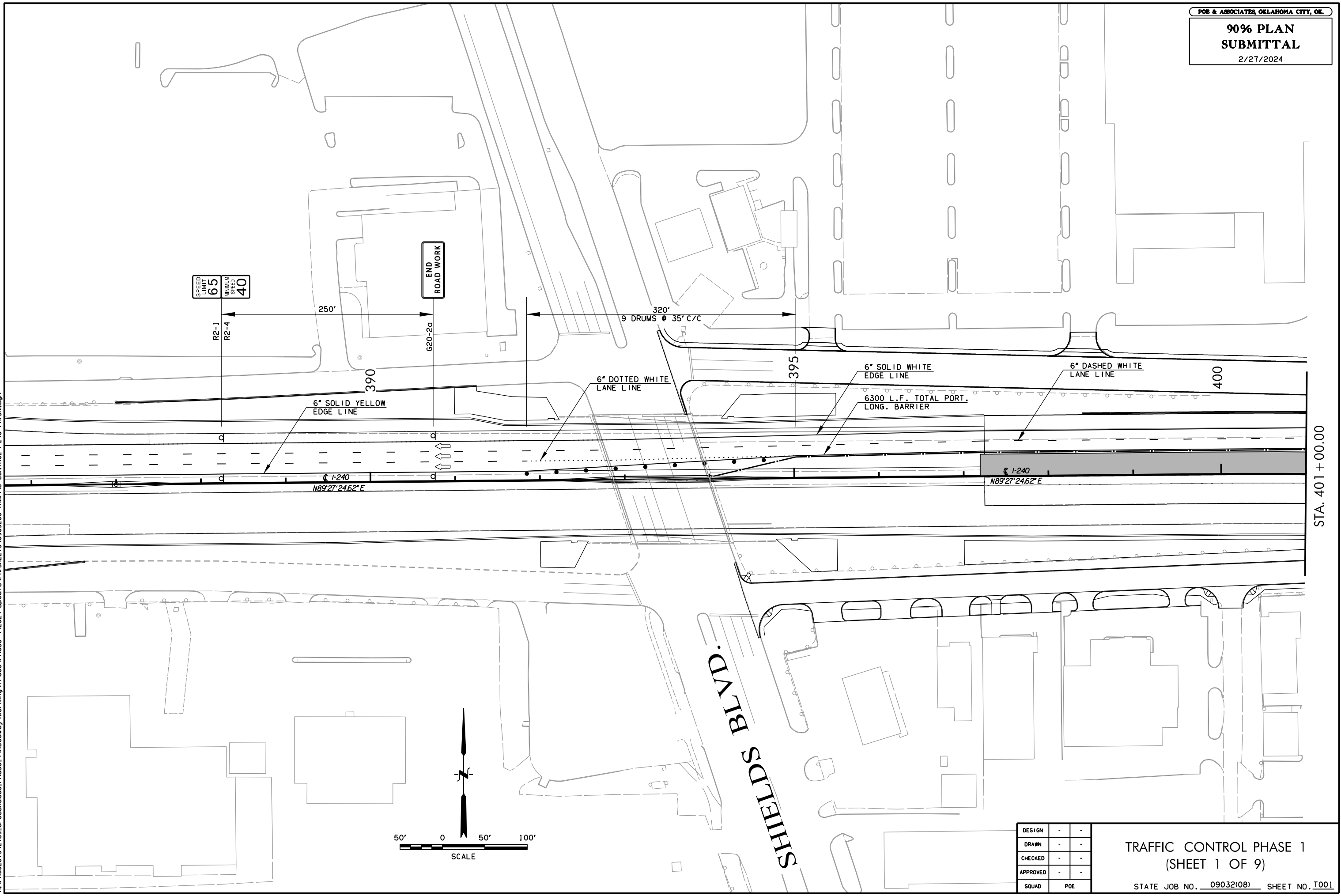

STA. 401+00.00

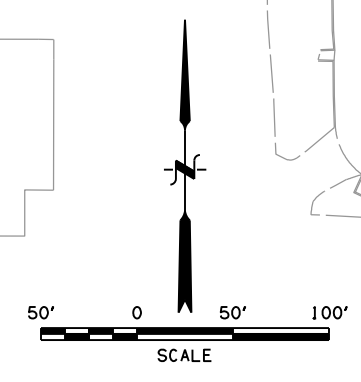

DESIGN	-	-
DRAWN	-	-
CHECKED	-	-
APPROVED	-	-
SQUAD	POE	

**TRAFFIC CONTROL PHASE 1
 (SHEET 1 OF 9)**
 STATE JOB NO. 090321081 SHEET NO. 1001

2/27/2024 12:22:49 PM
H:\PROJECTS\2789_CrossRoads_Phase 4\Roadway\Working\Trace\Phase 4\2024 Update\PHI SHEETS\0903208-TRAFFIC CONTROL I-240 PHI SH2.dgn

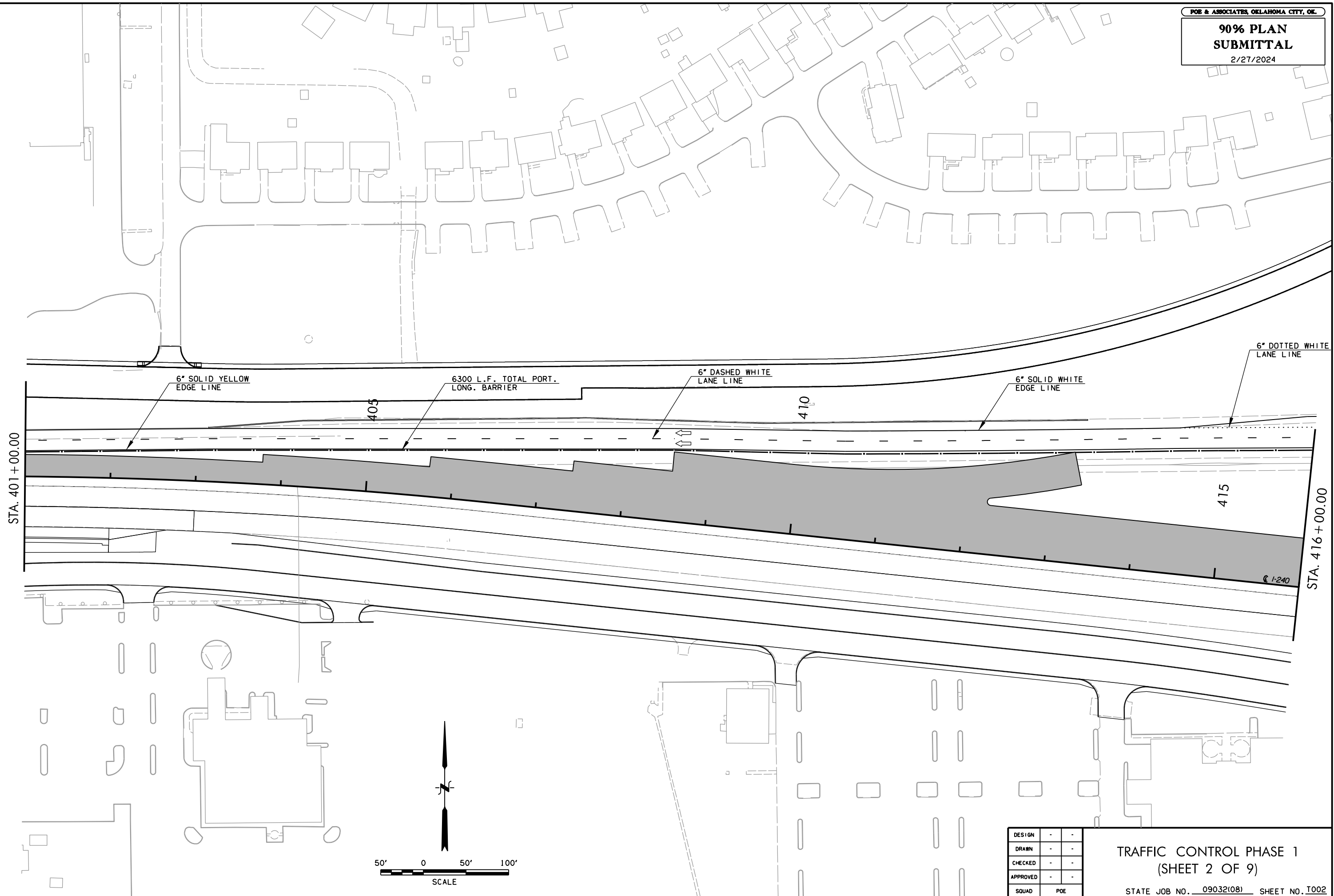

DESIGN	-	-
DRAWN	-	-
CHECKED	-	-
APPROVED	-	-
SQUAD	POE	

TRAFFIC CONTROL PHASE 1
(SHEET 2 OF 9)

STATE JOB NO. 090321081 SHEET NO. T002

2/27/2024 12:22:49 PM
H:\PROJECTS\2789_CrossRoads_Phase 4\Roadway\Working\Trace\Phase 4\2024 Update\PHI SHEETS\0903208-TRAFFIC CONTROL I-240 PHI SH3.dgn

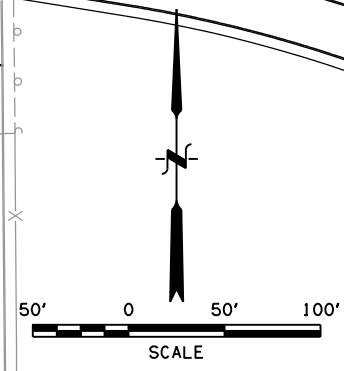
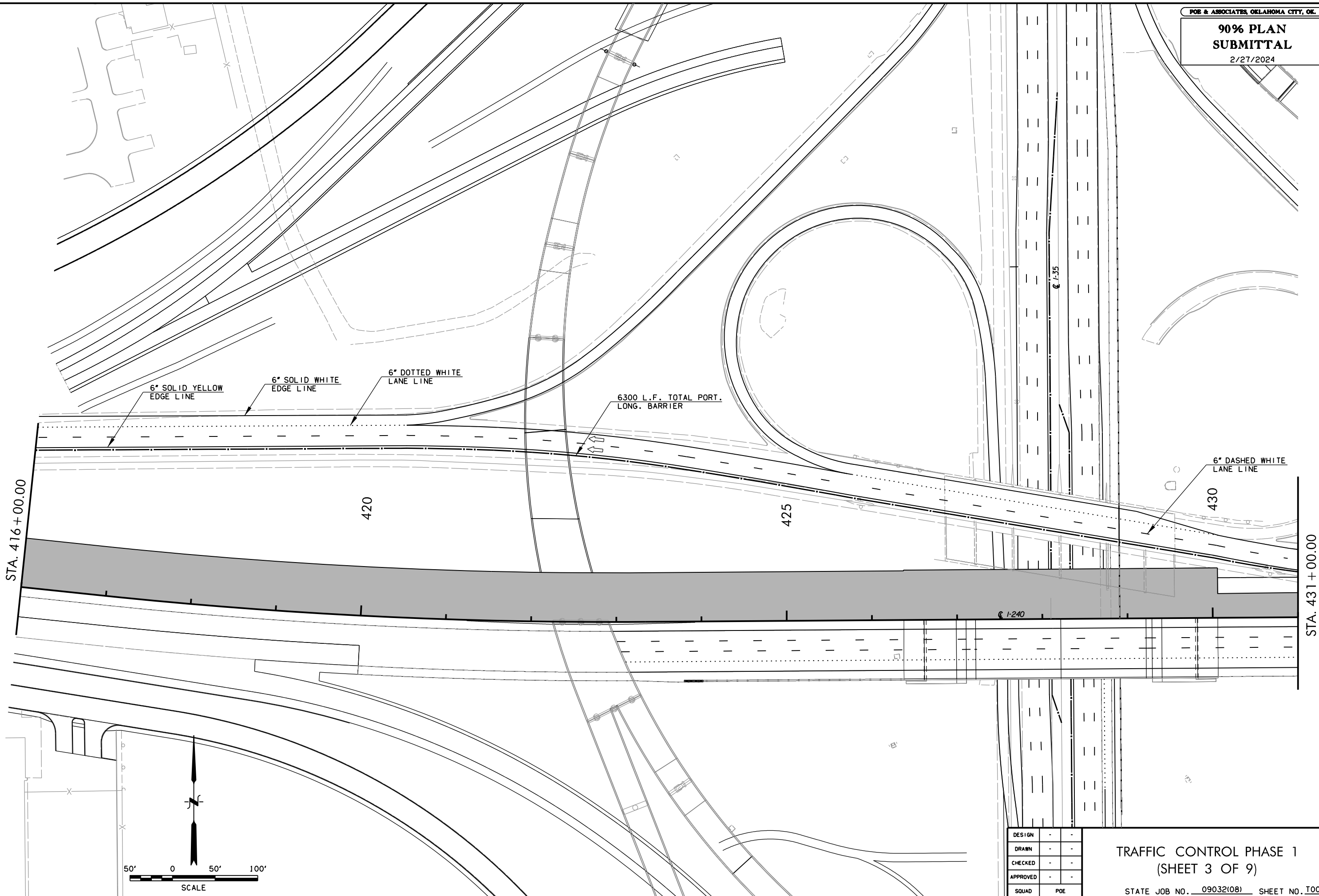

DESIGN	-	-
DRAWN	-	-
CHECKED	-	-
APPROVED	-	-
SQUAD	POE	

TRAFFIC CONTROL PHASE 1
(SHEET 3 OF 9)

STATE JOB NO. 090321081 SHEET NO. T003

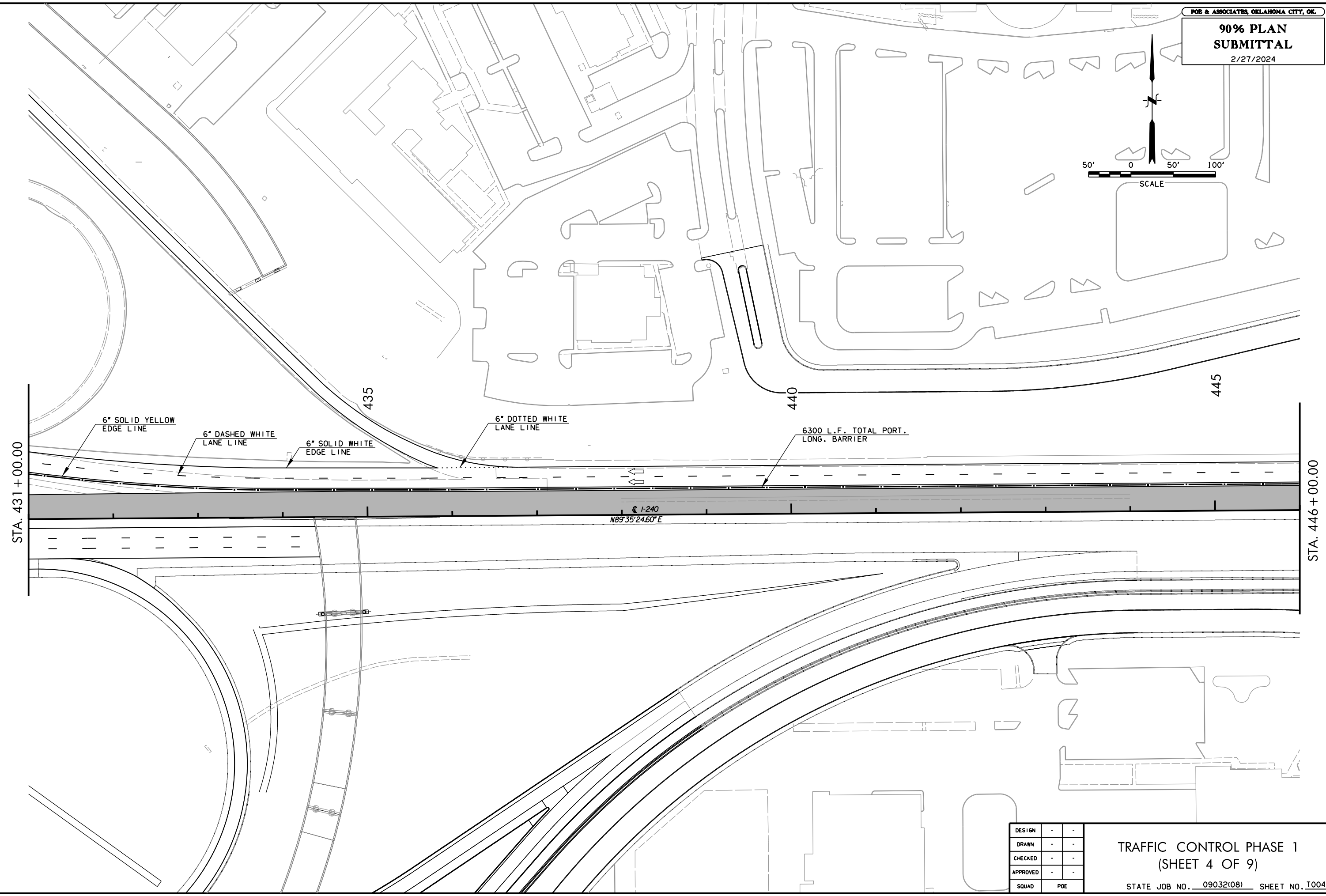
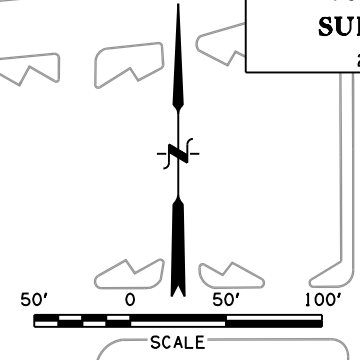

2/27/2024 12:22:50 PM
H:\PROJECTS\2789_CrossRoads_Phase 4\Roadway\Working\Trace\Phase 4\2024 Update\PHI SHEETS\0903208-TRAFFIC CONTROL I-240 PHI SH4.dgn

STA. 431+00.00

STA. 446+00.00

DESIGN	-	-
DRAWN	-	-
CHECKED	-	-
APPROVED	-	-
SQUAD	POE	

TRAFFIC CONTROL PHASE 1
(SHEET 4 OF 9)

STATE JOB NO. 090321081 SHEET NO. T004

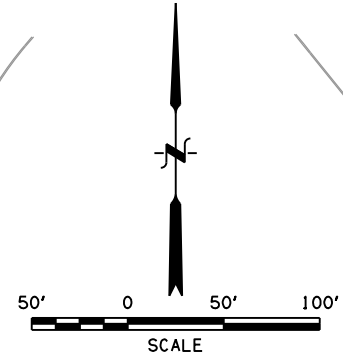

490' SHIFTING TAPER
28 DRUMS @ 35' C/C

615' TANGENT

455

460

STA. 446 + 00.00

STA. 461 + 00.00

6" SOLID YELLOW
EDGE LINE

6" SOLID WHITE
EDGE LINE

6300 L.F. TOTAL PORT.
LONG. BARRIER

6" DASHED WHITE
LANE LINE

@ 1:240

POLE RD.

2/27/2024 12:22:51 PM
H:\PROJECTS\2789_CrossRoads_Phase 4\Roadway\Working\Trace\Phase 4\2024 Update\PHI SHEETS\0903208-TRAFFIC CONTROL I-240 PHI SH5.dgn

DESIGN	-	-
DRAWN	-	-
CHECKED	-	-
APPROVED	-	-
SQUAD	POE	

TRAFFIC CONTROL PHASE 1
(SHEET 5 OF 9)

STATE JOB NO. 090321081 SHEET NO. 1005

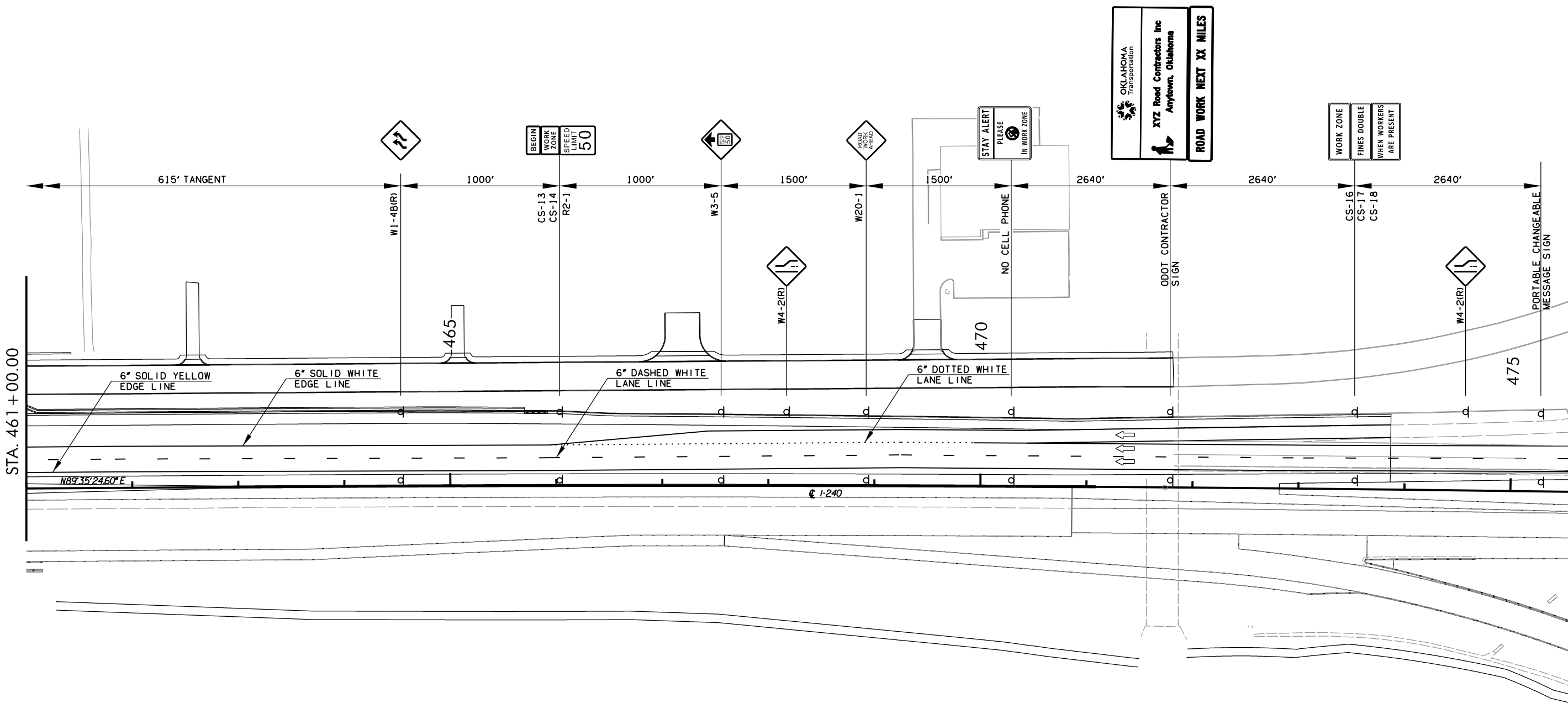
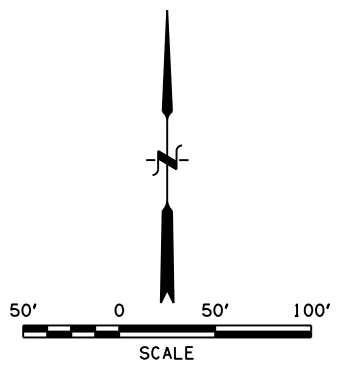

2/27/2024 12:22:52 PM H:\PROJECTS\2789_CrossRoads_Phase 4\Roadway\Working\Trace\Phase 4\2024 Update\PHI SHEETS\0903208-TRAFFIC CONTROL I-240 PHI SH6.dgn

DESIGN	-	-
DRAWN	-	-
CHECKED	-	-
APPROVED	-	-
SQUAD	POE	

TRAFFIC CONTROL PHASE 1
 (SHEET 6 OF 9)
 STATE JOB NO. 09032108 SHEET NO. 1006

2/27/2024 12:22:53 PM H:\PROJECTS\2789_CrossRoads_Phase 4\Roadway\Working\Trace\Phase 4\2024 Update\PHI SHEETS\0903208-TRAFFIC CONTROL 1-35 PHI SH.dgn

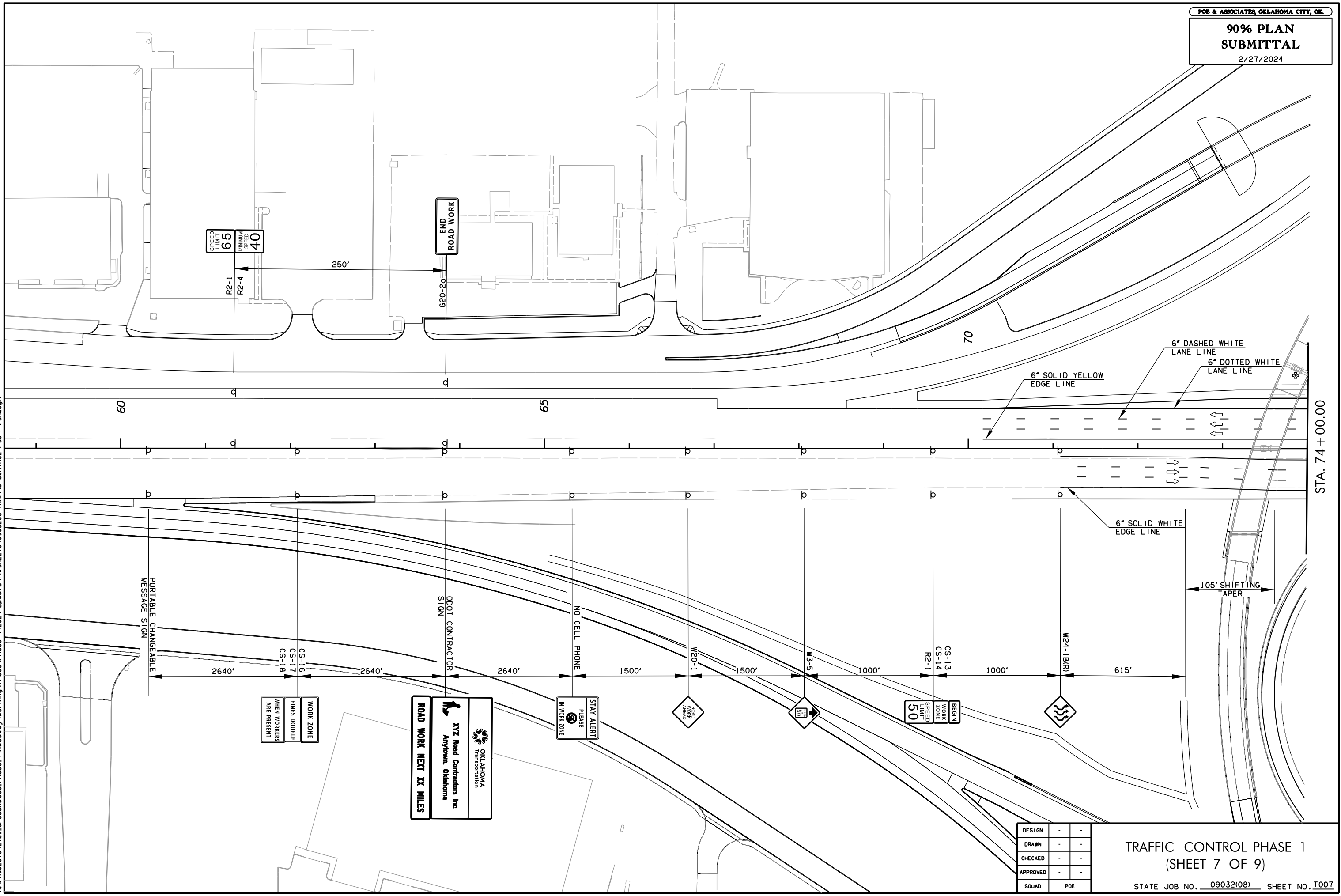

STA. 74 + 00.00

DESIGN	-	-
DRAWN	-	-
CHECKED	-	-
APPROVED	-	-
SQUAD	POE	

TRAFFIC CONTROL PHASE 1
(SHEET 7 OF 9)

2/27/2024 12:22:54 PM
H:\PROJECTS\2789_CrossRoads_Phase 4\Roadway\Working\Trace\Phase 4\2024 Update\PHI SHEETS\0903208-TRAFFIC CONTROL 1-35 PHI SH2.dgn

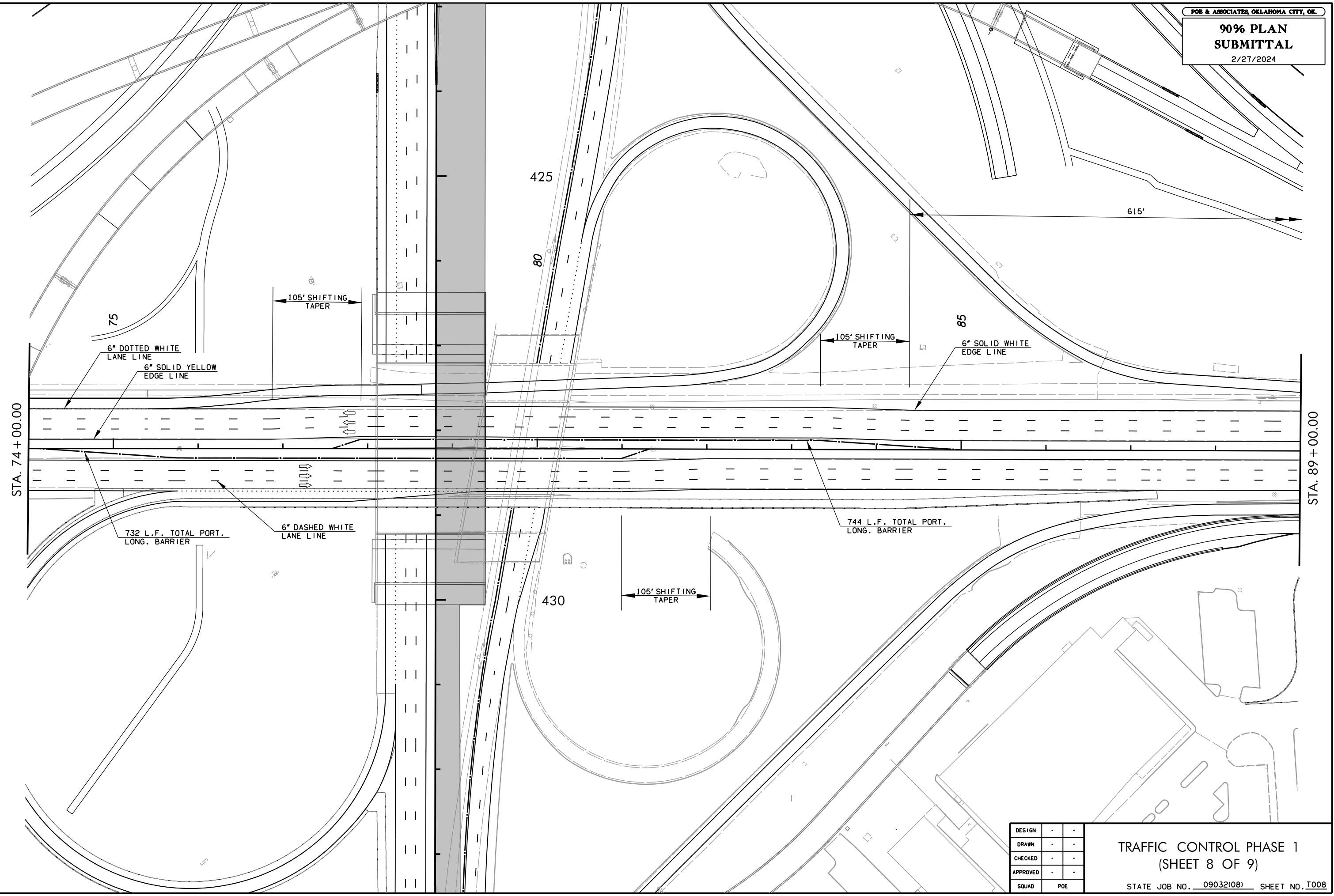

STA. 74 + 00.00

STA. 89 + 00.00

75

425

80

615'

85

430

6" DOTTED WHITE
LANE LINE
6" SOLID YELLOW
EDGE LINE

105' SHIFTING
TAPER

105' SHIFTING
TAPER

6" SOLID WHITE
EDGE LINE

732 L.F. TOTAL PORT.
LONG. BARRIER

6" DASHED WHITE
LANE LINE

744 L.F. TOTAL PORT.
LONG. BARRIER

105' SHIFTING
TAPER

DESIGN	-	-
DRAWN	-	-
CHECKED	-	-
APPROVED	-	-
SQUAD	POE	

TRAFFIC CONTROL PHASE 1
(SHEET 8 OF 9)

STATE JOB NO. 090321081 SHEET NO. T008

2/27/2024 12:22:55 PM
H:\PROJECTS\2789_CrossRoads_Phase 4\Roadway\Working\Trace\Phase 4\2024 Update\PHI SHEETS\0903208-TRAFFIC CONTROL 1-35 PHI SH3.dgn

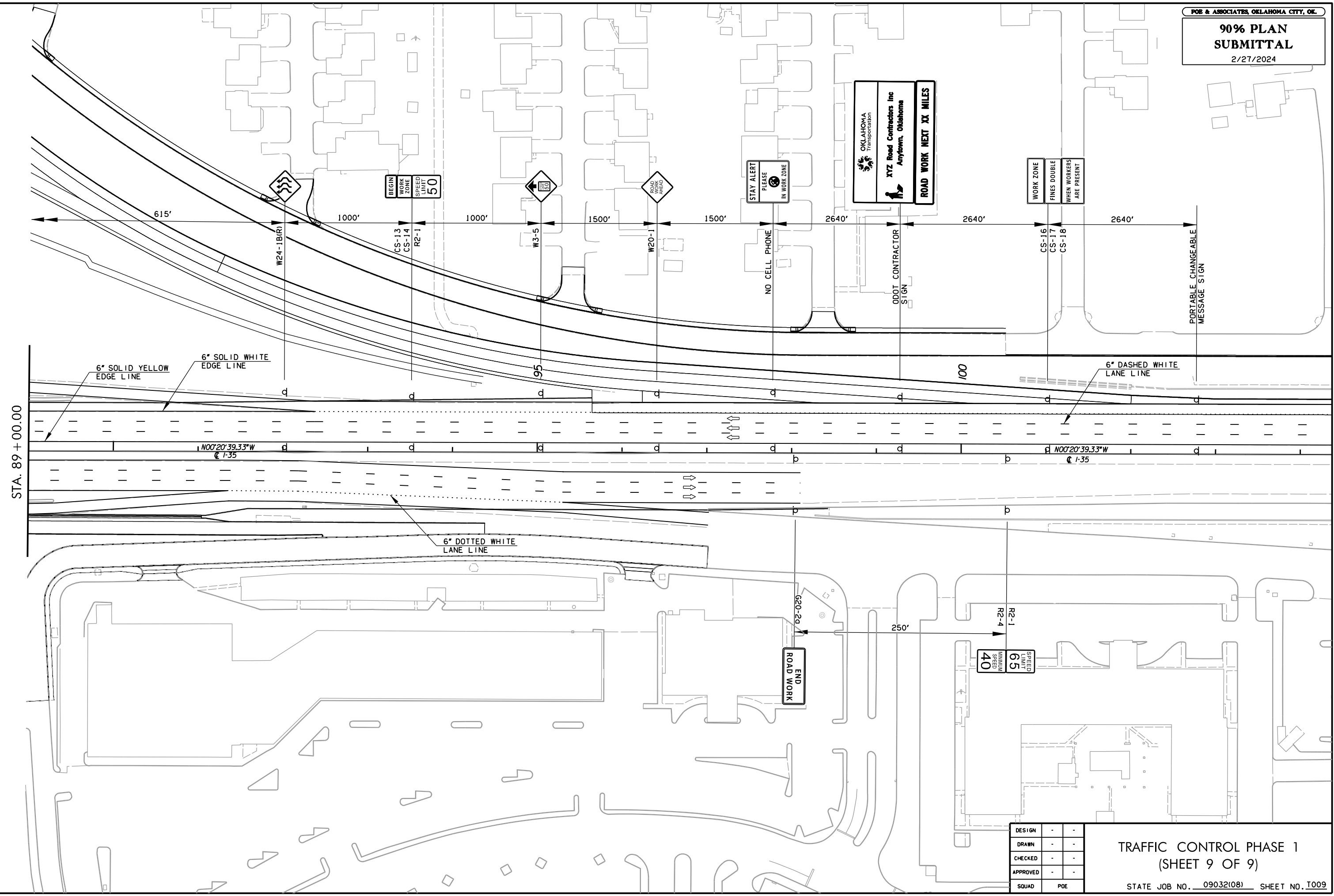

STA. 89 + 00.00

6" SOLID YELLOW
EDGE LINE

6" SOLID WHITE
EDGE LINE

6" DOTTED WHITE
LANE LINE

6" DASHED WHITE
LANE LINE

1000'20'39.33"W
@ 1:35

1000'20'39.33"W
@ 1:35

END
ROAD WORK

SPEED
LIMIT
65
MINIMUM
SPEED
40

DESIGN	-	-
DRAWN	-	-
CHECKED	-	-
APPROVED	-	-
SQUAD	POE	

TRAFFIC CONTROL PHASE 1
(SHEET 9 OF 9)

STATE JOB NO. 090321081 SHEET NO. 1009

2/27/2024 12:22:56 PM
 H:\PROJECTS\2789_CrossRoads_Phase 4\Roadway\Working\Trace\Phase 4\2024 Update\PH2 SHEETS\0903208-TRAFFIC CONTROL I-240 PH2 SHI.dgn

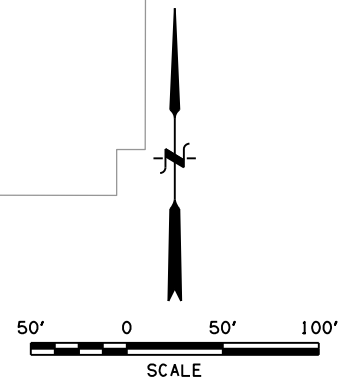
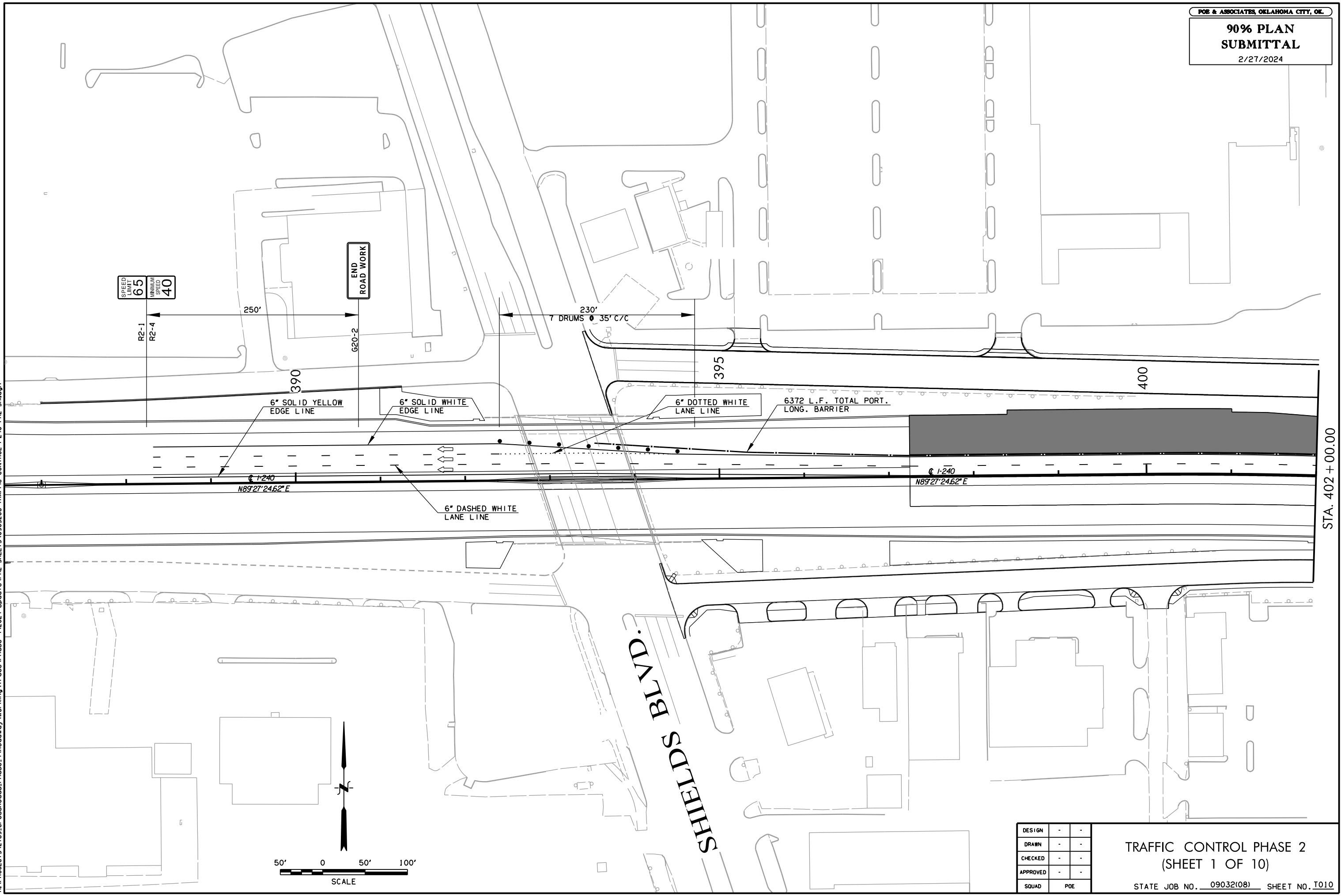

DESIGN	-	-
DRAWN	-	-
CHECKED	-	-
APPROVED	-	-
SQUAD	POE	

**TRAFFIC CONTROL PHASE 2
 (SHEET 1 OF 10)**
 STATE JOB NO. 09032108 SHEET NO. 1010

2/27/2024 12:22:57 PM
H:\PROJECTS\2789_CrossRoads_Phase 4\Roadway\Working\Trace\Phase 4\2024 Update\PH2 SHEETS\0903208-TRAFFIC CONTROL 1-240 PH2 SH2.dgn

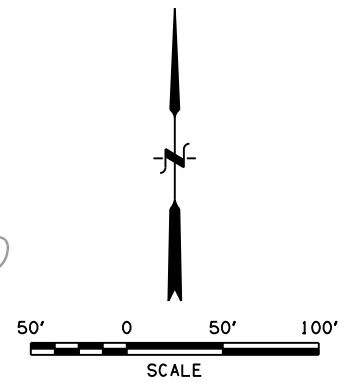
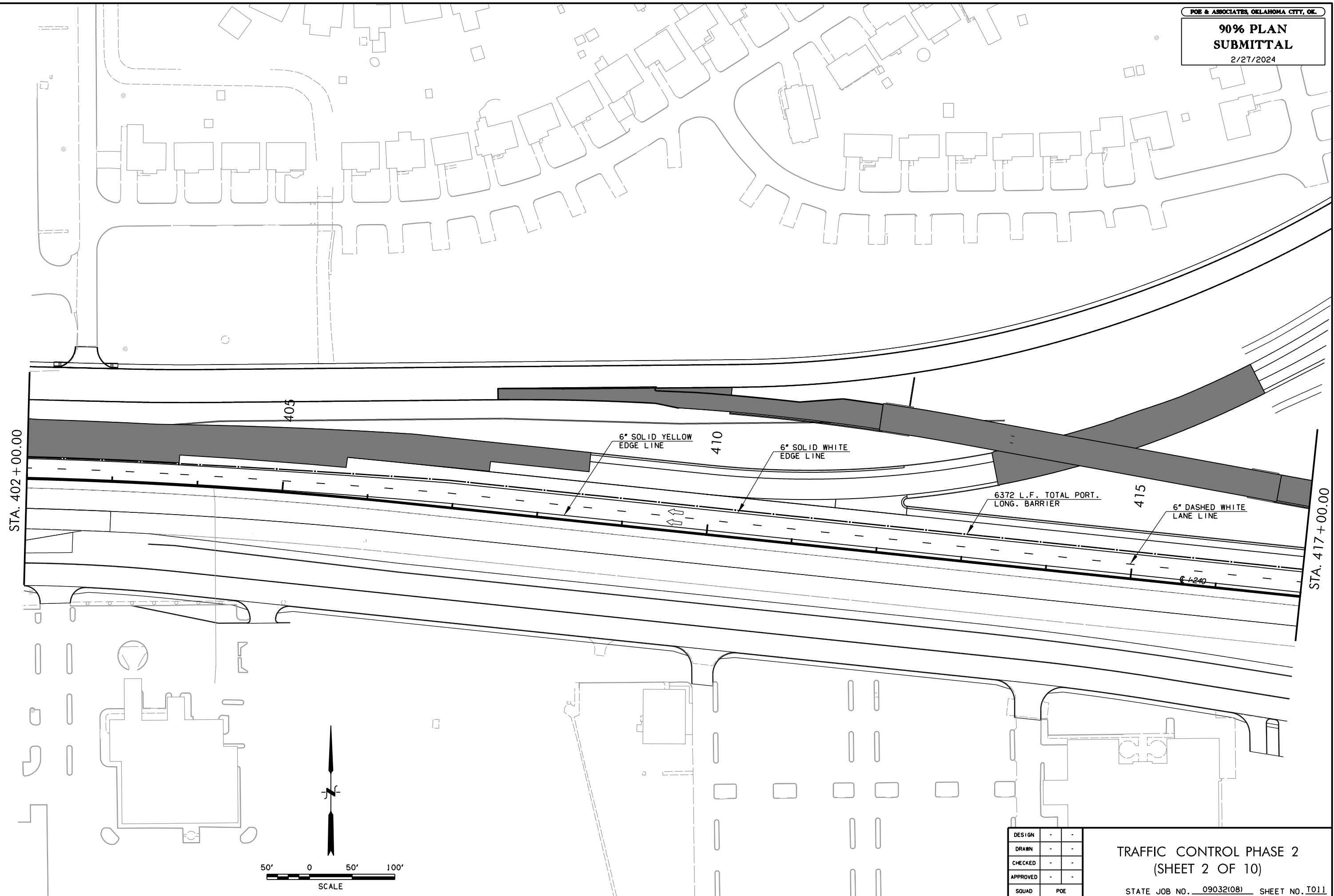

DESIGN	-	-
DRAWN	-	-
CHECKED	-	-
APPROVED	-	-
SQUAD	POE	

TRAFFIC CONTROL PHASE 2
(SHEET 2 OF 10)

STATE JOB NO. 09032108 SHEET NO. T011

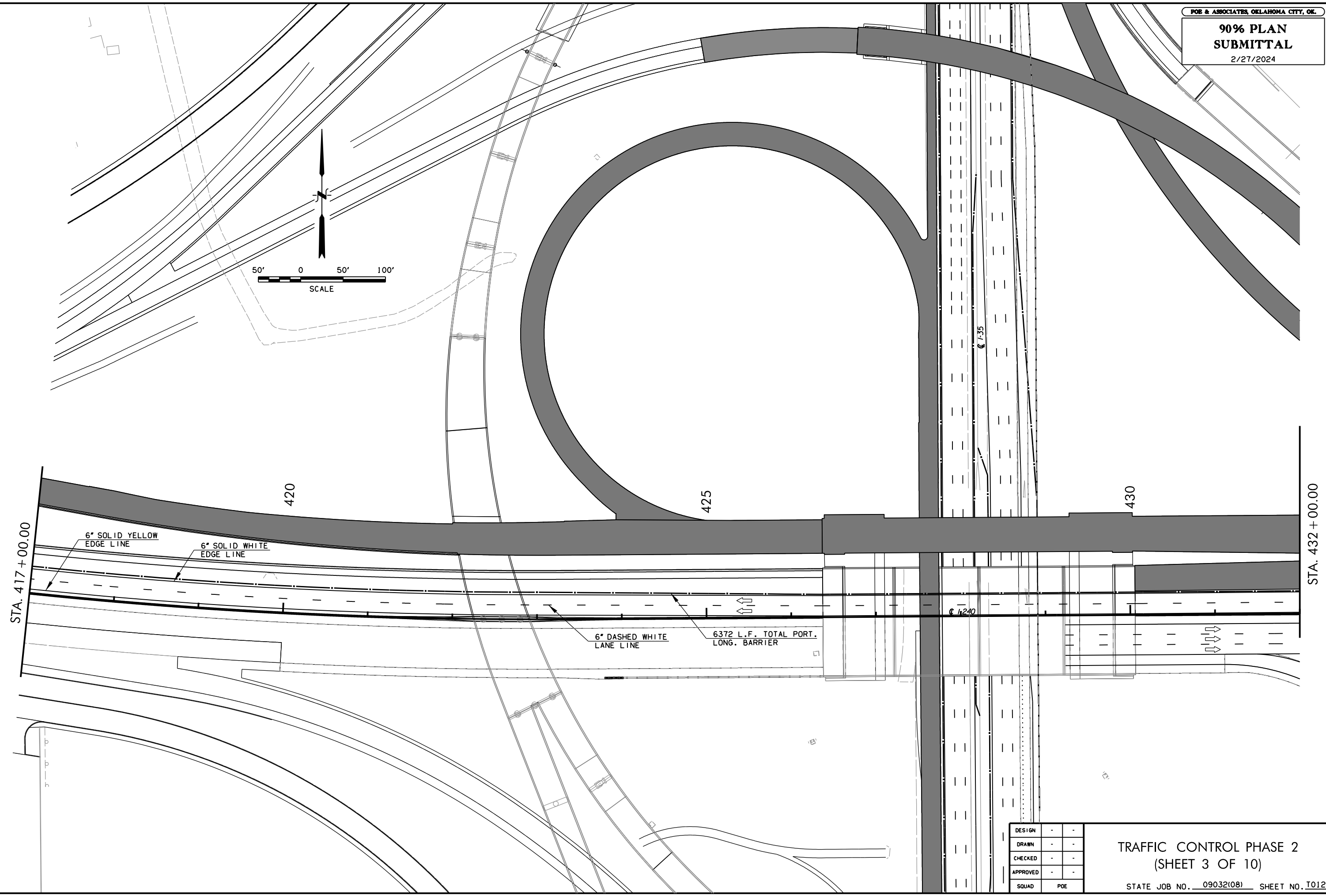
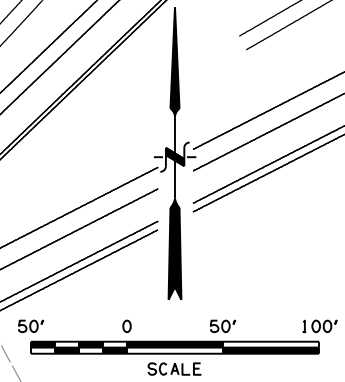

2/27/2024 12:22:58 PM
H:\PROJECTS\2789_CrossRoads_Phase 4\Roadway\Working\Trace\Phase 4\2024 Update\PH2 SHEETS\0903208-TRAFFIC CONTROL 1-240 PH2 SH3.dgn

STA. 417 + 00.00

STA. 432 + 00.00

6" SOLID YELLOW
EDGE LINE
6" SOLID WHITE
EDGE LINE

6" DASHED WHITE
LANE LINE
6372 L.F. TOTAL PORT.
LONG. BARRIER

DESIGN	-	-
DRAWN	-	-
CHECKED	-	-
APPROVED	-	-
SQUAD	POE	

TRAFFIC CONTROL PHASE 2
(SHEET 3 OF 10)

STATE JOB NO. 090321081 SHEET NO. T012

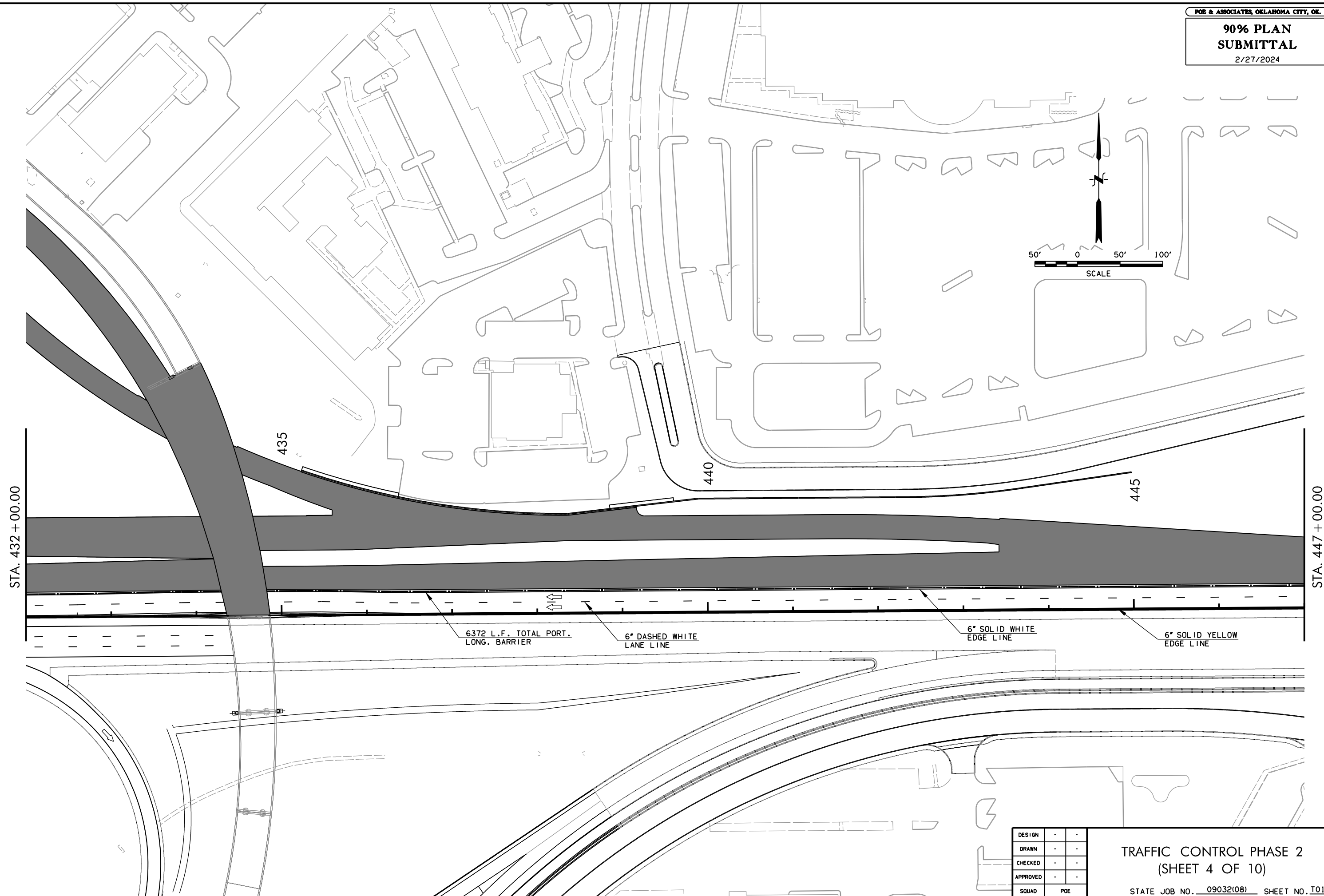
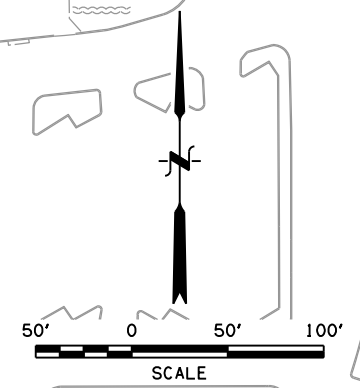

STA. 432 + 00.00

STA. 447 + 00.00

435

440

445

6372 L.F. TOTAL PORT.
LONG. BARRIER

6" DASHED WHITE
LANE LINE

6" SOLID WHITE
EDGE LINE

6" SOLID YELLOW
EDGE LINE

2/27/2024 12:22:59 PM
H:\PROJECTS\2789_CrossRoads_Phase 4\Roadway\Working\Trace\Phase 4\2024 Update\PH2 SHEETS\0903208-TRAFFIC CONTROL 1-240 PH2 SH4.dgn

DESIGN	-	-
DRAWN	-	-
CHECKED	-	-
APPROVED	-	-
SQUAD	POE	

TRAFFIC CONTROL PHASE 2
(SHEET 4 OF 10)

STATE JOB NO. 090321081 SHEET NO. T013

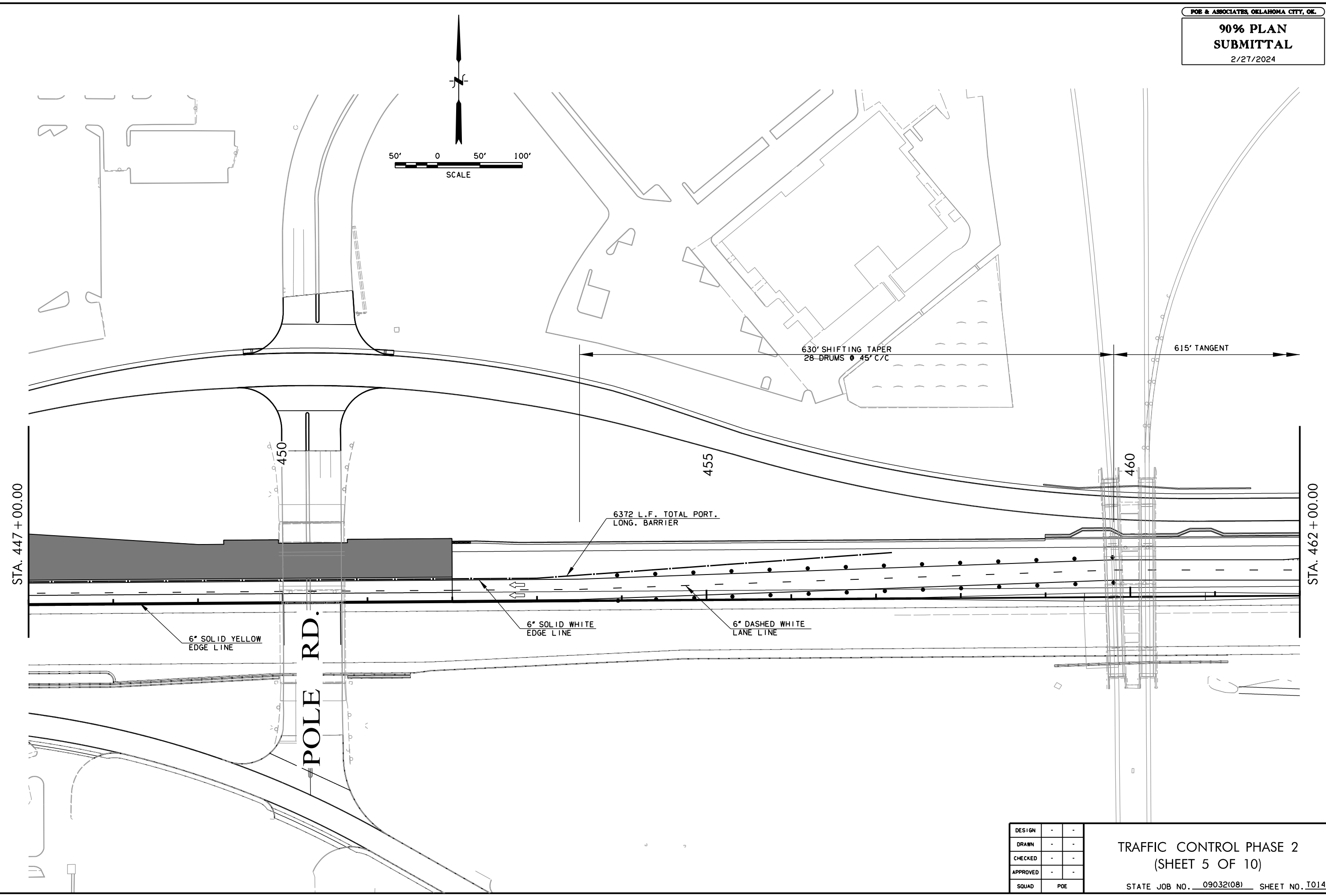
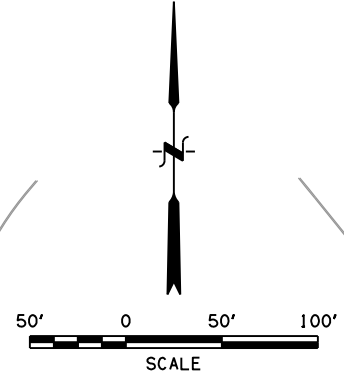

2/27/2024 12:23:00 PM
H:\PROJECTS\2789_CrossRoads_Phase 4\Roadway\Working\Trace\Phase 4\2024 Update\PH2 SHEETS\0903208-TRAFFIC CONTROL I-240 PH2 SH5.dgn

DESIGN	-	-
DRAWN	-	-
CHECKED	-	-
APPROVED	-	-
SQUAD	POE	

TRAFFIC CONTROL PHASE 2
(SHEET 5 OF 10)

STATE JOB NO. 09032(08) SHEET NO. T014

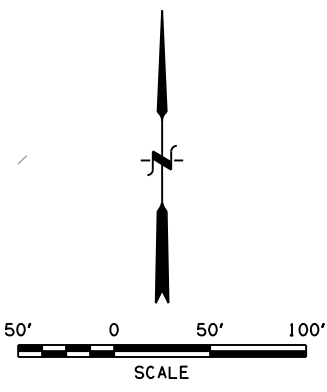

36

2/27/2024 12:23:01 PM H:\PROJECTS\2789_CrossRoads_Phase 4\Roadway\Working\Trace\Phase 4\2024 Update\PH2 SHEETS\0903208-TRAFFIC CONTROL 1-240 PH2 SH6.dgn

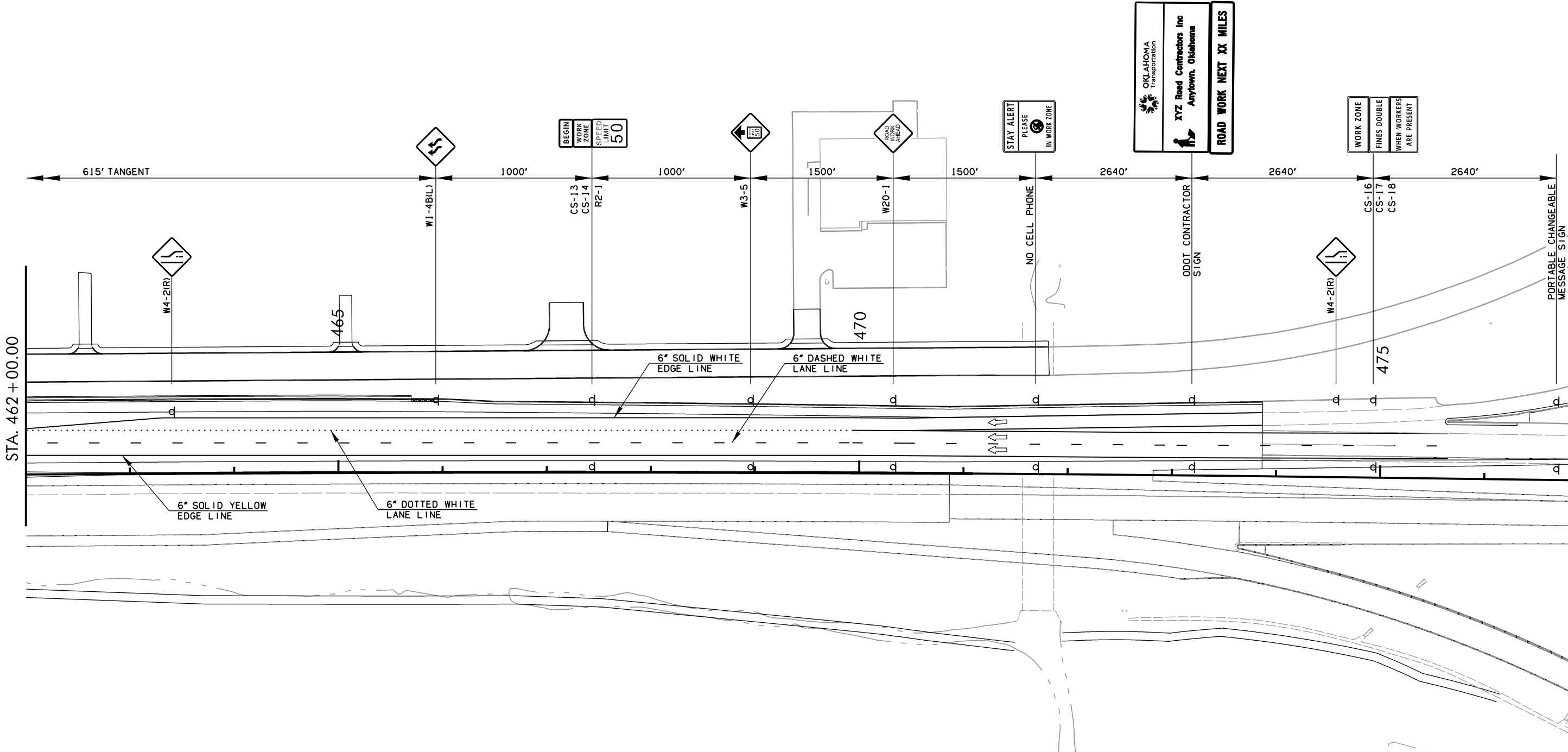

DESIGN	-	-
DRAWN	-	-
CHECKED	-	-
APPROVED	-	-
SQUAD	POE	

**TRAFFIC CONTROL PHASE 2
 (SHEET 6 OF 10)**
 STATE JOB NO. 090321081 SHEET NO. T015

2/27/2024 12:23:02 PM
 H:\PROJECTS\2789_CrossRoads_Phase 4\Roadway\Working\Trace\Phase 4\2024 Update\PH2 SHEETS\0903208-TRAFFIC CONTROL 1-35 PH2 SH.dgn

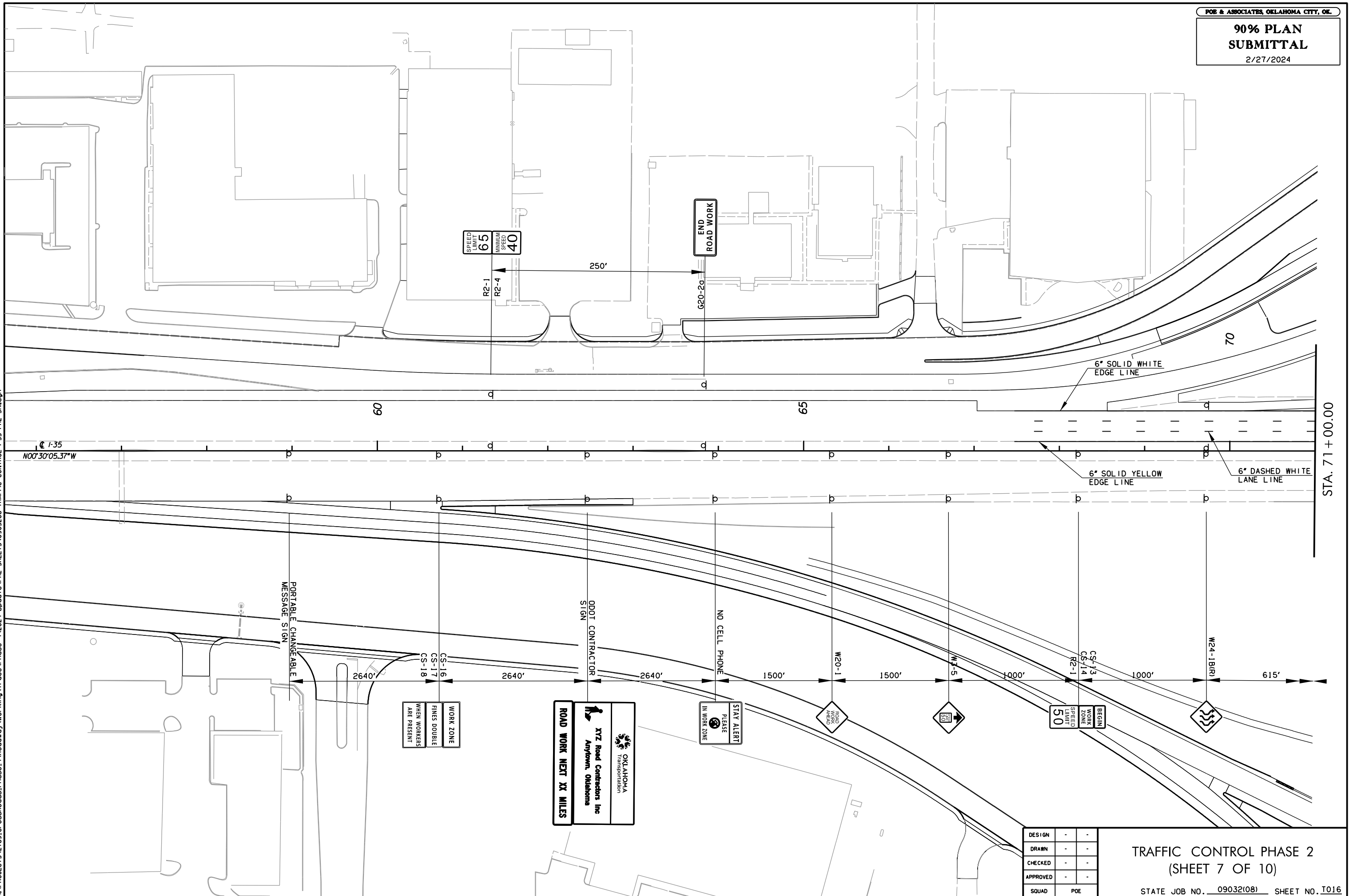

STA. 71+00.00

DESIGN	-	-
DRAWN	-	-
CHECKED	-	-
APPROVED	-	-
SQUAD	POE	

**TRAFFIC CONTROL PHASE 2
 (SHEET 7 OF 10)**

STATE JOB NO. 090321081 SHEET NO. T016

**OKLAHOMA
 Transportation**
XYZ Road Contractors Inc
 Anytown, Oklahoma
ROAD WORK NEXT XX MILES

**WORK ZONE
 FINES DOUBLE
 WHEN WORKERS
 ARE PRESENT**

2/27/2024 12:23:03 PM
H:\PROJECTS\2789_CrossRoads_Phase 4\Roadway\Working\Trace\Phase 4\2024 Update\PH2 SHEETS\0903208-TRAFFIC CONTROL 1-35 PH2 SH2.dgn

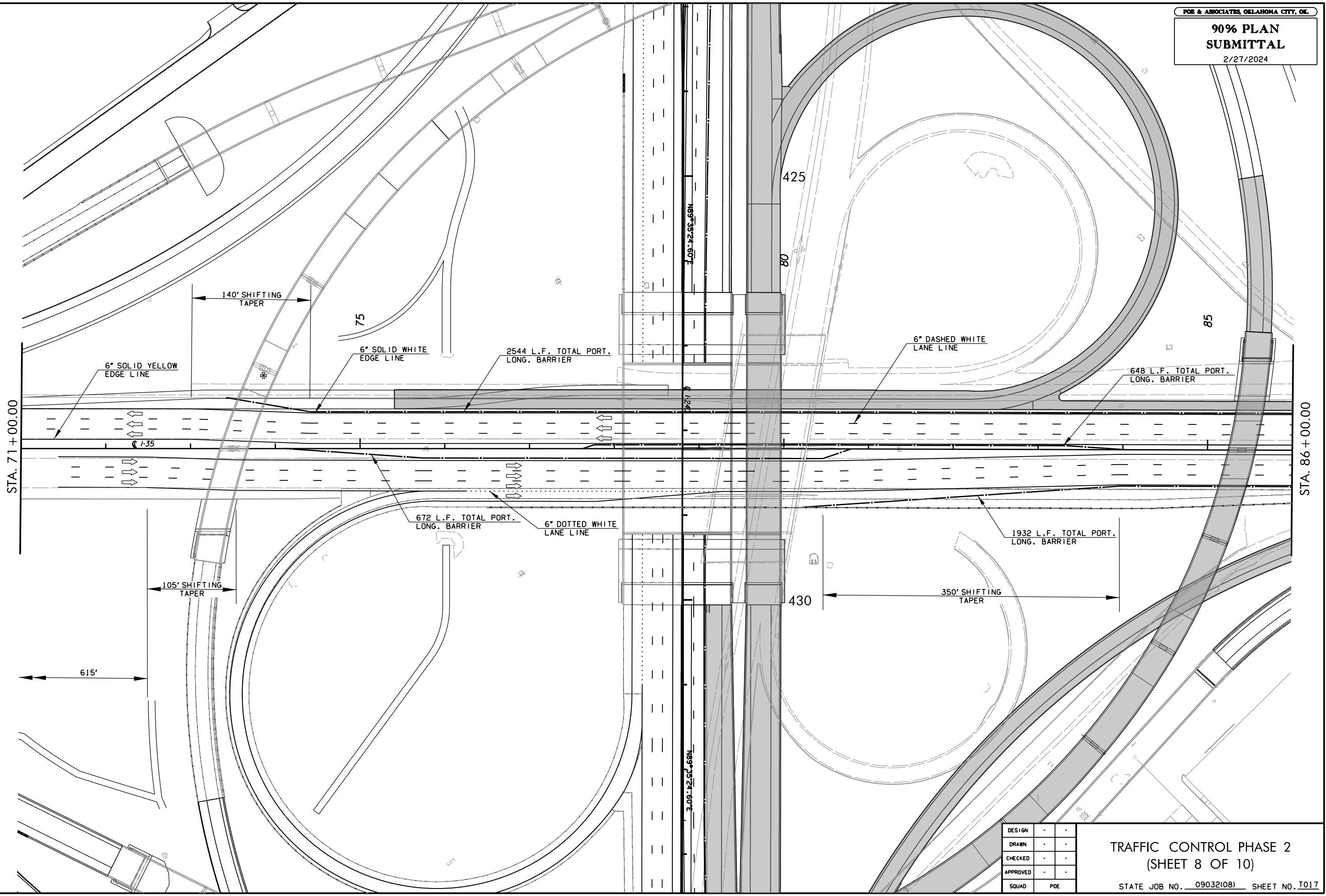

DESIGN	-	-
DRAWN	-	-
CHECKED	-	-
APPROVED	-	-
SQUAD	POE	

TRAFFIC CONTROL PHASE 2
(SHEET 8 OF 10)

2/27/2024 12:23:04 PM
H:\PROJECTS\2789_CrossRoads_Phase 4\Roadway\Working\Trace\Phase 4\2024 Update\PH2 SHEETS\0903208-TRAFFIC CONTROL 1-35 PH2 SH3.dgn

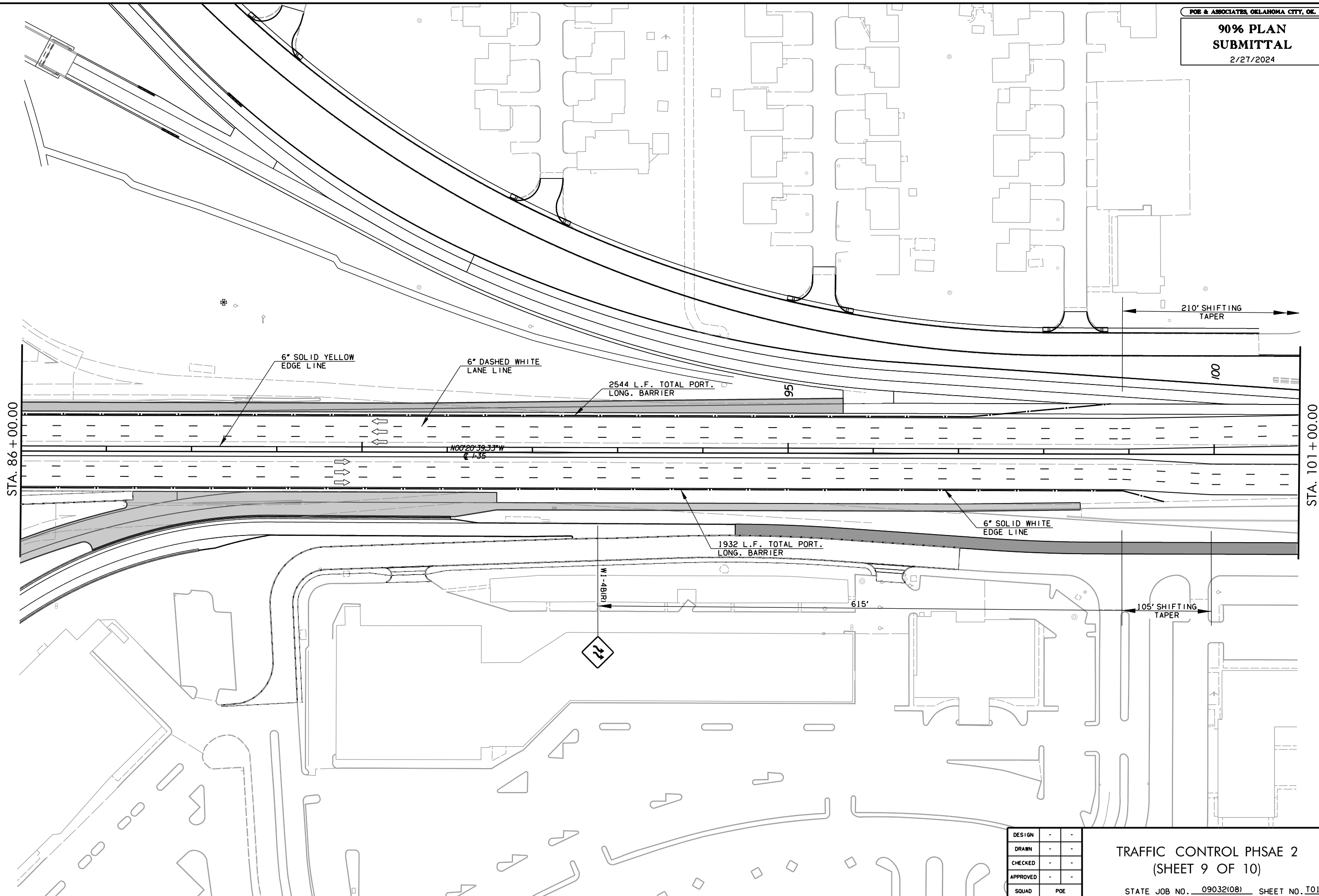

DESIGN	-	-
DRAWN	-	-
CHECKED	-	-
APPROVED	-	-
SQUAD	POE	

TRAFFIC CONTROL PHSAE 2
(SHEET 9 OF 10)

2/27/2024 12:23:05 PM
 H:\PROJECTS\2789_CrossRoads_Phase 4\Roadway\Working\Trace\Phase 4\2024 Update\PH2 SHEETS\0903208-TRAFFIC CONTROL 1-35 PH2 SH4.dgn

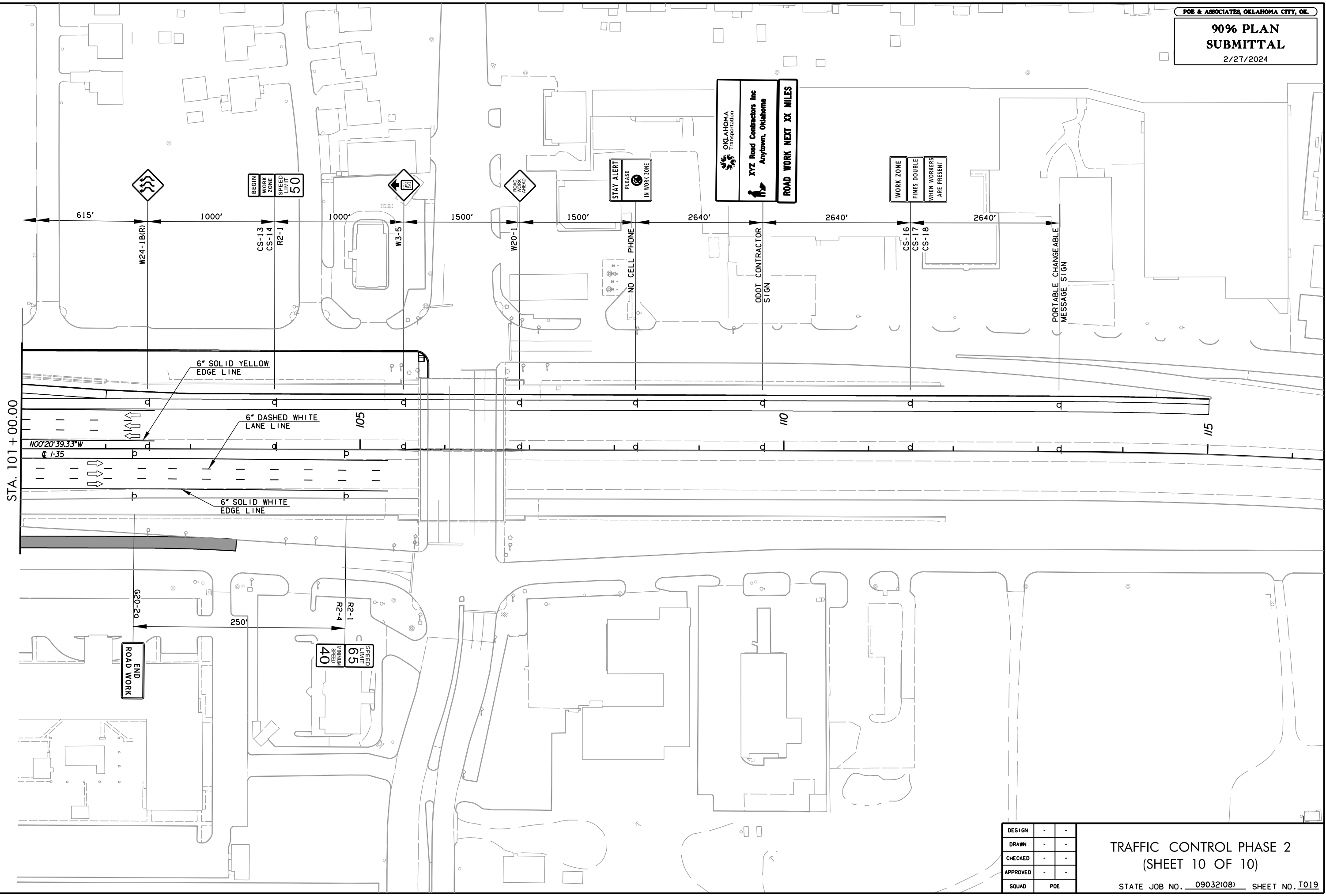

DESIGN	-	-
DRAWN	-	-
CHECKED	-	-
APPROVED	-	-
SQUAD	POE	

REVISIONS		
NO.	DESCRIPTION	DATE



SPECIAL SIGN NO.	1			
WIDTH x HGHT.	24'-0" x 13'-0"			
BORDER WIDTH	2"			
CORNER RADIUS	12"			
MOUNTING	Overhead			
SIGN AREA	318.25 Sq.Ft.			
BACKGROUND	TYPE: Reflective COLOR: Green			
LEGENDBORDER	TYPE: Reflective COLOR: White			
SYMBOL	X	Y	WID	HT
I-5	0	0	29.99	30
M1_1	74.94	87.04	60	48
ARROWN	9.02	16.46	29.99	20.58
ARROWN	129.02	16.46	29.99	20.58
ARROWN	249.02	16.46	29.99	20.58

Dimensions are in: Inches.tenths Letter locations are panel edge to lower left corner

LETTER POSITIONS (X)										LENGTH	SERIES / SIZE
W	E	S	T								E 2000
152.94	174.69	188.04	201.84							60.15	
L	a	w	t	o	n						EM 2000
89.71	107.11	126.11	150.31	165.31	185.11					108.6	



SPECIAL SIGN NO.	2			
WIDTH x HGHT.	22'-6" x 11'-0"			
BORDER WIDTH	2"			
CORNER RADIUS	12"			
MOUNTING	Overhead			
SIGN AREA	271.26 Sq.Ft.			
BACKGROUND	TYPE: Reflective COLOR: Green			
LEGENDBORDER	TYPE: Reflective COLOR: White			
SYMBOL	X	Y	WID	HT
ARROWN	118	8.02	32	21.96

Dimensions are in: Inches.tenths Letter locations are panel edge to lower left corner

LETTER POSITIONS (X)										LENGTH	SERIES / SIZE
E	X	I	T	3							E 2000
26.84	36.53	48.22	52.72	75.22						60.73	
S	a	n	t	a	F	e	A	v	e		EM 2000
22	42.6	63.8	83	98	115.2	138	156.4	171.8	192.6	226	
1/4	M	I	L	E							E 2000
95.96	134.33	148.73	154.01	165.05						78.09	
E	X	I	T								EM 2000
63.48	74.72	88.69	94.12							39.52	
O	N	L	Y								EM 2000
162	174.97	188.06	197.67							47.79	

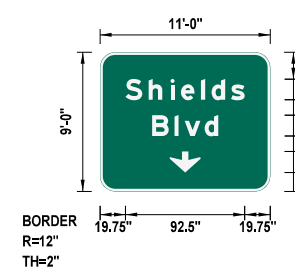

SPECIAL SIGN NO.	3			
WIDTH x HGHT.	11'-0" x 9'-0"			
BORDER WIDTH	2"			
CORNER RADIUS	12"			
MOUNTING	Overhead			
SIGN AREA	99 Sq.Ft.			
BACKGROUND	TYPE: Reflective COLOR: Green			
LEGENDBORDER	TYPE: Reflective COLOR: White			
SYMBOL	X	Y	WID	HT
ARROWN	54	14.57	23.99	16.47

Dimensions are in: Inches.tenths Letter locations are panel edge to lower left corner

LETTER POSITIONS (X)										LENGTH	SERIES / SIZE
S	h	i	e	l	d	s					EM 2000
19.76	37.68	54.64	62.8	78.32	86.48	101.68				92.48	
B	l	v	d								EM 2000
40.32	57.76	65.6	81.12							51.36	

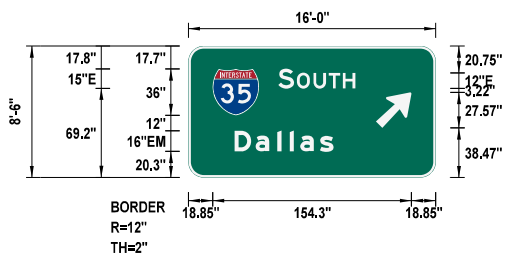

SPECIAL SIGN NO.	4			
WIDTH x HGHT.	16'-0" x 8'-6"			
BORDER WIDTH	2"			
CORNER RADIUS	12"			
MOUNTING	Overhead			
SIGN AREA	136 Sq.Ft.			
BACKGROUND	TYPE: Reflective COLOR: Green			
LEGENDBORDER	TYPE: Reflective COLOR: White			
SYMBOL	X	Y	WID	HT
M1_1	18.84	48.25	36	36
AR_Type A	145.6	38.47	22.23	35.01

Dimensions are in: Inches.tenths Letter locations are panel edge to lower left corner

LETTER POSITIONS (X)										LENGTH	SERIES / SIZE
S	O	U	T	H							E 2000
69.84	84.24	97.08	108.84	119.88						59.76	
D	a	l	l	a	s						EM 2000
35.82	52.14	69.1	78.7	86.86	102.06					76.8	

03-12-24 G:\0\Projects\T-245\IE Design\I-240-I-35 Phase IV - OK\CAD\T02-0903208-SPECIAL SIGN DETAILS I.DWG

Design MSH 03-12-24
 Drawn CCC 03-12-24

REVISIONS		
NO.	DESCRIPTION	DATE

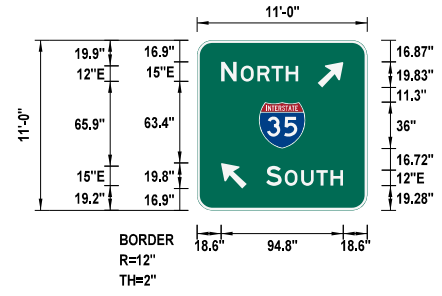

SPECIAL SIGN NO.	5
WIDTH x HGHT.	11'-0" x 11'-0"
BORDER WIDTH	2"
CORNER RADIUS	12"
MOUNTING	Ground
SIGN AREA	121 Sq.Ft.
BACKGROUND	TYPE: Reflective COLOR: Green
LEGENDBORDER	TYPE: Reflective COLOR: White

SYMBOL	X	Y	WID	HT
AR_Type A	93.55	95.3	15.99	25.19
M1_1	48	48	36	36
AR_Type A	18.7	16.87	15.99	25.19

Dimensions are in: Inches.tenths Letter locations are panel edge to lower left corner

LETTER POSITIONS (X)					LENGTH	SERIES / SIZE
N	O	R	T	H		E 2000
18.61	33.91	46.75	57.79	68.83	59.94	
S	O	U	T	H		E 2000
53.54	67.94	80.78	92.54	103.58	59.76	



SPECIAL SIGN NO.	6
WIDTH x HGHT.	17'-0" x 12'-6"
BORDER WIDTH	2"
CORNER RADIUS	12"
MOUNTING	Overhead
SIGN AREA	212.5 Sq.Ft.
BACKGROUND	TYPE: Reflective COLOR: Green
LEGENDBORDER	TYPE: Reflective COLOR: White

SYMBOL	X	Y	WID	HT
M1_1	46.62	97.28	36	36
ARDOWN	90	12.82	23.99	16.47

Dimensions are in: Inches.tenths Letter locations are panel edge to lower left corner

LETTER POSITIONS (X)					LENGTH	SERIES / SIZE							
S	O	U	T	H		E 2000							
97.62	112.02	124.86	136.62	147.66	59.76								
D	a	l	l	a	s		EM 2000						
63.6	79.92	96.88	106.48	114.64	129.84	76.8							
S	h	i	e	l	d	s	B	l	v	d		EM 2000	
20.08	38	54.96	63.12	78.64	86.8	102	114.32	132.56	150	157.84	173.36	163.84	

Dimensions are in: Inches.tenths Letter locations are panel edge to lower left corner

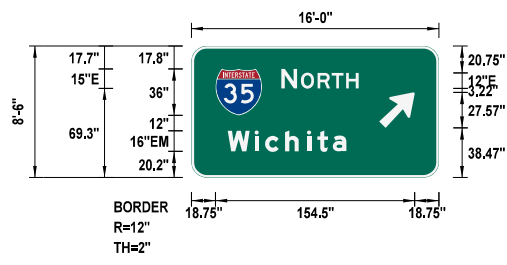

SPECIAL SIGN NO.	7
WIDTH x HGHT.	16'-0" x 8'-6"
BORDER WIDTH	2"
CORNER RADIUS	12"
MOUNTING	Overhead
SIGN AREA	136 Sq.Ft.
BACKGROUND	TYPE: Reflective COLOR: Green
LEGENDBORDER	TYPE: Reflective COLOR: White

SYMBOL	X	Y	WID	HT
M1_1	18.75	48.25	36	36
AR_Type A	145.69	38.47	22.23	35.01

Dimensions are in: Inches.tenths Letter locations are panel edge to lower left corner

LETTER POSITIONS (X)					LENGTH	SERIES / SIZE		
N	O	R	T	H		E 2000		
69.75	85.05	97.89	108.93	119.97	59.94			
W	i	c	h	i	t	a		EM 2000
28.22	49.02	57.18	72.7	89.66	97.66	109.66	92	

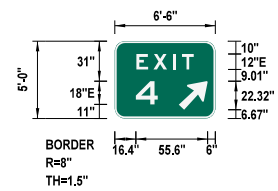

SPECIAL SIGN NO.	8 (E5-1a)
WIDTH x HGHT.	6'-6" x 5'-0"
BORDER WIDTH	1.5"
CORNER RADIUS	8"
MOUNTING	Ground
SIGN AREA	32.5 Sq.Ft.
BACKGROUND	TYPE: Reflective COLOR: Green
LEGENDBORDER	TYPE: Reflective COLOR: White

SYMBOL	X	Y	WID	HT
AR_Type A	49.67	6.67	17.99	28.35

Dimensions are in: Inches.tenths Letter locations are panel edge to lower left corner

LETTER POSITIONS (X)				LENGTH	SERIES / SIZE
E	X	I	T		E 2000
16.81	30.05	45.44	52.19	44.38	
4					E 2000
16.38				16.92	

03-12-24 G:\Projects\1-245\TE Design\1-240-1-35 Phase IV - OK\CAD\T022-0903208-SPECIAL SIGN DETAILS 2 OF 11.dgn

Design	MSH	03-12-24
Drawn	CCC	03-12-24



SPECIAL SIGN DETAILS 2 OF 11

State Job No. 09032(08) Sheet No. T022

REVISIONS		
NO.	DESCRIPTION	DATE



SPECIAL SIGN NO.	9			
WIDTH x HIGHT.	14'-6" x 16'-6"			
BORDER WIDTH	2"			
CORNER RADIUS	12"			
MOUNTING	Overhead			
SIGN AREA	263 Sq.Ft.			
BACKGROUND	TYPE: Reflective COLOR: Green			
LEGENDBORDER	TYPE: Reflective COLOR: White			
SYMBOL	X	Y	WID	HT
M1_1	63	127	48	48
AR_Type A	71	5	22.58	35.56

Dimensions are In: Inches.tenths Letter locations are panel edge to lower left corner

LETTER POSITIONS (X)												LENGTH	SERIES / SIZE
E	X	I	T	4								60.73	E 2000
26.64	35.88	46.92	50.77	73.27									
W	I	C	H	I	T	A						115	EM 2000
29.5	55.5	65.7	85.1	106.3	116.3	131.3							
D	A	I	L	A	S							96	EM 2000
39	59.4	80.6	92.6	102.8	121.8								
E	X	I	T									39.52	EM 2000
19.48	30.71	44.69	50.12										
O	N	L	Y									47.79	EM 2000
111	123.97	137.06	146.67										

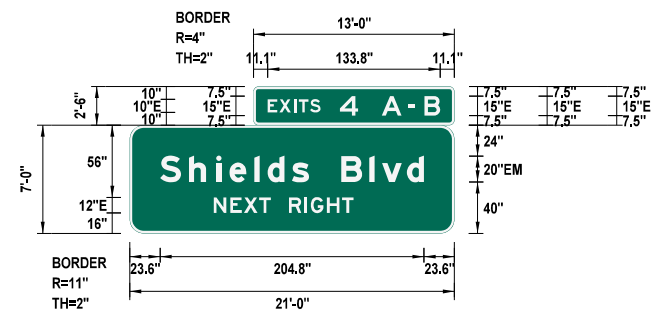

SPECIAL SIGN NO.	10			
WIDTH x HIGHT.	21'-0" x 7'-0"			
BORDER WIDTH	2"			
CORNER RADIUS	11"			
MOUNTING	Ground			
SIGN AREA	179.51 Sq.Ft.			
BACKGROUND	TYPE: Reflective COLOR: Green			
LEGENDBORDER	TYPE: Reflective COLOR: White			
SYMBOL	X	Y	WID	HT

Dimensions are In: Inches.tenths Letter locations are panel edge to lower left corner

LETTER POSITIONS (X)												LENGTH	SERIES / SIZE
E	X	I	T	S								41.04	E 2000
11.09	20.27	31.37	35.21	44.03									
4												14.1	E 2000
67.13													
A	-	B										45.2	E 2000
99.73	120.03	132.78											
S	H	I	E	L	D	S	B	L	V	D		204.8	EM 2000
23.6	46	67.2	77.4	96.8	107	126	141.4	164.2	186	195.8	215.2		
N	E	X	T		R	I	G	H	T			108.6	E 2000
65.2	78.04	88.72	100.48	109.96	123.52	135.64	140.56	153.04	164.8				



SPECIAL SIGN NO.	11			
WIDTH x HIGHT.	13'-6" x 16'-0"			
BORDER WIDTH	2"			
CORNER RADIUS	12"			
MOUNTING	Overhead			
SIGN AREA	239.75 Sq.Ft.			
BACKGROUND	TYPE: Reflective COLOR: Green			
LEGENDBORDER	TYPE: Reflective COLOR: White			
SYMBOL	X	Y	WID	HT
M1_1	57	120.65	48	48

Dimensions are In: Inches.tenths Letter locations are panel edge to lower left corner

LETTER POSITIONS (X)												LENGTH	SERIES / SIZE
E	X	I	T	4								60.73	E 2000
26.64	35.88	46.92	50.77	73.27									
W	I	C	H	I	T	A						115	EM 2000
23.5	49.5	59.7	79.1	100.3	110.3	125.3							
D	A	I	L	A	S							96	EM 2000
33	53.4	74.6	86.6	96.8	115.8								
1	M	I	L	E								63.12	E 2000
49.44	72.84	87.24	92.52	103.56									



SPECIAL SIGN NO.	12			
WIDTH x HIGHT.	17'-6" x 8'-6"			
BORDER WIDTH	2"			
CORNER RADIUS	12"			
MOUNTING	Overhead			
SIGN AREA	172.5 Sq.Ft.			
BACKGROUND	TYPE: Reflective COLOR: Green			
LEGENDBORDER	TYPE: Reflective COLOR: White			
SYMBOL	X	Y	WID	HT
AR_Type A	161.2	38.61	19.99	31.49

Dimensions are In: Inches.tenths Letter locations are panel edge to lower left corner

LETTER POSITIONS (X)												LENGTH	SERIES / SIZE
E	X	I	T	S								60.73	E 2000
26.63	36.53	48.22	52.72	75.22									
E	A	S	T	E	R	N						117.2	EM 2000
24	42.4	61.4	78.8	93.8	113.2	128							
A	V	E										55.4	EM 2000
54.9	77.7	97.1											

03-12-24 G:\Projects\1-245\TE Design\1-240-1-35 Phase IV - OK\CAD\1023-0903208-SPECIAL SIGN DETAILS 3 OF 11.dgn

Design	MSH	03-12-24
Drawn	CCC	03-12-24



SPECIAL SIGN DETAILS
3 OF 11

REVISIONS		
NO.	DESCRIPTION	DATE



SPECIAL SIGN NO.	13
WIDTH x HIGHT.	13'-6" x 16'-0"
BORDER WIDTH	2"
CORNER RADIUS	12"
MOUNTING	Overhead
SIGN AREA	239.75 Sq.Ft.
BACKGROUND	TYPE: Reflective COLOR: Green
LEGENDBORDER	TYPE: Reflective COLOR: White

SYMBOL	X	Y	WID	HT
M1_1	57	120.65	48	48

Dimensions are in: Inches.tenths Letter locations are panel edge to lower left corner

LETTER POSITIONS (X)											LENGTH	SERIES / SIZE
E	X	I	T	4							60.73	E 2000
26.64	35.88	46.92	50.77	73.27								
W	I	C	H	I	T	A					115	EM 2000
23.5	49.5	59.7	79.1	100.3	110.3	125.3						
D	A	I	L	A	S						96	EM 2000
33	53.4	74.6	86.6	96.8	115.8							
2	M	I	L	E	S						83.7	E 2000
39.15	71.73	86.13	91.41	102.45	113.13							

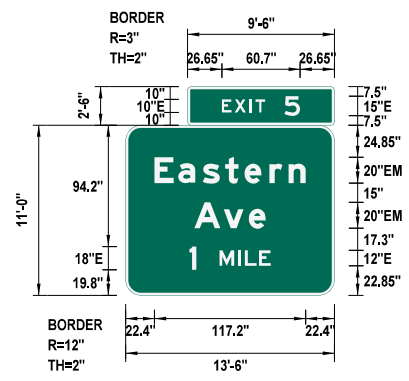

SPECIAL SIGN NO.	14
WIDTH x HIGHT.	13'-6" x 11'-0"
BORDER WIDTH	2"
CORNER RADIUS	12"
MOUNTING	Overhead
SIGN AREA	172.25 Sq.Ft.
BACKGROUND	TYPE: Reflective COLOR: Green
LEGENDBORDER	TYPE: Reflective COLOR: White

SYMBOL	X	Y	WID	HT

Dimensions are in: Inches.tenths Letter locations are panel edge to lower left corner

LETTER POSITIONS (X)											LENGTH	SERIES / SIZE
E	X	I	T	S							60.73	E 2000
26.63	36.53	48.22	52.72	75.22								
E	A	S	T	E	R	N					117.2	EM 2000
22.4	40.8	59.8	77.2	92.2	111.6	126.4						
A	V	E									55.4	EM 2000
53.3	76.1	95.5										
1	M	I	L	E							63.12	E 2000
49.44	72.84	87.24	92.52	103.56								

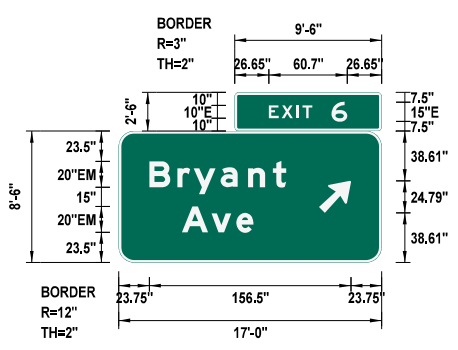

SPECIAL SIGN NO.	15
WIDTH x HIGHT.	17'-0" x 8'-6"
BORDER WIDTH	2"
CORNER RADIUS	12"
MOUNTING	Overhead
SIGN AREA	168.25 Sq.Ft.
BACKGROUND	TYPE: Reflective COLOR: Green
LEGENDBORDER	TYPE: Reflective COLOR: White

SYMBOL	X	Y	WID	HT
AR_Type A	155.46	38.61	19.99	31.49

Dimensions are in: Inches.tenths Letter locations are panel edge to lower left corner

LETTER POSITIONS (X)											LENGTH	SERIES / SIZE
E	X	I	T	6							60.73	E 2000
26.63	36.53	48.22	52.72	75.22								
B	R	Y	A	N	T						106.2	EM 2000
23.76	45.56	58.16	79.16	100.36	119.56							
A	V	E									55.4	EM 2000
49.15	71.95	91.35										

SPECIAL SIGN NO.	
WIDTH x HIGHT.	
BORDER WIDTH	
CORNER RADIUS	
MOUNTING	
SIGN AREA	
BACKGROUND	TYPE: COLOR:
LEGENDBORDER	TYPE: COLOR:

SYMBOL	X	Y	WID	HT

LETTER POSITIONS (X)											LENGTH	SERIES / SIZE

03-12-24 G:\Projects\1-245\TE Design\1-240-I-35 Phase IV - OKLA CAD\T024-0903208-SPECIAL SIGN DETAILS 4 OF 11.dgn

Design	MSH	03-12-24
Drawn	CCC	03-12-24



SPECIAL SIGN DETAILS
4 OF 11

State Job No. _09032(08) Sheet No. _T024

REVISIONS		
NO.	DESCRIPTION	DATE

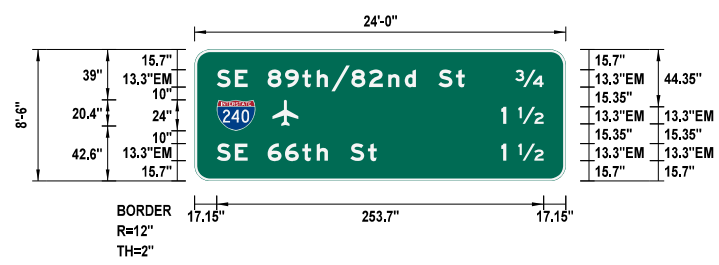

SPECIAL SIGN NO.	16
WIDTH x HIGHT.	24'-0" x 8'-6"
BORDER WIDTH	2"
CORNER RADIUS	12"
MOUNTING	Overhead
SIGN AREA	204 Sq.Ft.
BACKGROUND	TYPE: Reflective COLOR: Green
LEGENDBORDER	TYPE: Reflective COLOR: White

SYMBOL	X	Y	WID	HT
Alrport	60.47	42.6	19.94	20.4
M1_1	17.17	39	30	24

Dimensions are in: Inches.tenths Letter locations are panel edge to lower left corner

LETTER POSITIONS (X)															LENGTH	SERIES / SIZE	
S	E	8	9	t	h	/	8	2	n	d	S	t	3/4			253.67	EM 2000
17.17	31.26	42.04	56.67	70.1	83.53	94.71	106.14	121.7	135.27	150.17	163.07	174.51	189.27	202.83	248.69		
1	1/2															32.79	EM 2000
238.04	251.35																
S	E	6	6	t	h	S	t	1	1/2							253.67	EM 2000
17.17	31.26	42.04	56.67	70.1	83.53	94.71	106.14	120.91	134.47	238.04	251.35						

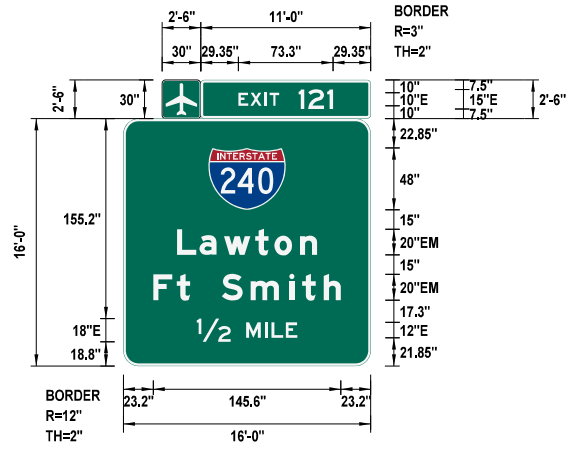

SPECIAL SIGN NO.	17
WIDTH x HIGHT.	16'-0" x 16'-0"
BORDER WIDTH	2"
CORNER RADIUS	12"
MOUNTING	Overhead
SIGN AREA	289.75 Sq.Ft.
BACKGROUND	TYPE: Reflective COLOR: Green
LEGENDBORDER	TYPE: Reflective COLOR: White

SYMBOL	X	Y	WID	HT
I-5	0	0	29.99	30
M1_1	66	121.15	60	48

Dimensions are in: Inches.tenths Letter locations are panel edge to lower left corner

LETTER POSITIONS (X)															LENGTH	SERIES / SIZE	
E	X	I	T													31.63	E 2000
29.34	38.58	49.62	53.47														
1	2	1														26.7	E 2000
75.97	83.47	98.17															
L	a	w	t	o	n											108.6	EM 2000
41.7	59.1	78.1	102.3	117.3	137.1												
F	t	S	m	i	t	h										145.6	EM 2000
23.2	41.4	54.2	76.4	98.8	128.8	138.8	155.6										
1/2	M	I	L	E												78.09	E 2000
56.96	95.33	109.73	115.01	126.05													



SPECIAL SIGN NO.	18
WIDTH x HIGHT.	19'-6" x 7'-0"
BORDER WIDTH	2"
CORNER RADIUS	11"
MOUNTING	Ground
SIGN AREA	164.01 Sq.Ft.
BACKGROUND	TYPE: Reflective COLOR: Green
LEGENDBORDER	TYPE: Reflective COLOR: White

SYMBOL	X	Y	WID	HT
--------	---	---	-----	----

Dimensions are in: Inches.tenths Letter locations are panel edge to lower left corner

LETTER POSITIONS (X)															LENGTH	SERIES / SIZE	
E	X	I	T													31.63	E 2000
29.34	38.58	49.62	53.47														
1	2	1														26.7	E 2000
75.97	83.47	98.17															
S	E	6	6	t	h	S	t									186.8	EM 2000
23.6	44.8	61	83	103.2	123.4	140.2	157.4	179.6	200								
N	E	X	T	R	I	G	H	T								108.6	E 2000
65.2	78.04	88.72	100.48	109.96	123.52	135.64	140.56	153.04	164.8								

SPECIAL SIGN NO.	
WIDTH x HIGHT.	
BORDER WIDTH	
CORNER RADIUS	
MOUNTING	
SIGN AREA	
BACKGROUND	TYPE:
	COLOR:
LEGENDBORDER	TYPE:
	COLOR:

SYMBOL	X	Y	WID	HT
--------	---	---	-----	----

LETTER POSITIONS (X)															LENGTH	SERIES / SIZE
----------------------	--	--	--	--	--	--	--	--	--	--	--	--	--	--	--------	---------------

Design MSH 03-12-24
Drawn CCC 03-12-24



SPECIAL SIGN DETAILS
5 OF 11

03-12-24 G:\0\Projects\T-245\TE Design\I-240-I-35 Phase IV - OK\CAD\T025-0903208-SPECIAL SIGN DETAILS 5 OF 11.dgn

REVISIONS		
NO.	DESCRIPTION	DATE



SPECIAL SIGN NO.	19
WIDTH x HIGHT	46'-0" x 18'-6"
BORDER WIDTH	2"
CORNER RADIUS	12"
MOUNTING	Overhead
SIGN AREA	884.75 Sq.Ft.
BACKGROUND	TYPE: Reflective COLOR: Green
LEGEND/BORDER	TYPE: Reflective COLOR: White

SYMBOL	X	Y	WID	HT
I-5	0	0	29.99	30
M1_1	101.57	153.85	48	48
M1_1	411.69	153.85	60	48
AR_THRU	16.89	16.15	19.99	72
AR_THRU	160.89	16.15	19.99	72
AR_THRU_RIGHT	304.89	16.15	53.32	72
AR_RIGHT_ONLY	454.78	16.15	38.34	47.59

Dimensions are in: inches,tenths

Letter locations are panel edge to lower left corner

LETTER POSITIONS (X)

		LENGTH		SERIES / SIZE				
E	X	I	T		E 2000			
29.34	38.58	49.62	53.47		31.63			
1	2	1			E 2000			
75.97	83.47	98.17			26.7			
N	O	R	T	H	E 2000			
167.57	184.4	200.45	214.25	228.05	72.63			
D	a	i	l	a	s	EM 2000		
122.88	143.28	164.48	176.48	186.68	205.68	96		
L	a	w	t	o	n	EM 2000		
387.39	404.79	423.79	447.99	462.99	482.79	108.6		
F	t	S	m	i	t	h	EM 2000	
368.89	387.09	399.89	422.09	444.49	474.49	484.49	501.29	145.6
E	X	I	T		E 2000			
394.42	405.1	417.94	422.14		36.72			
O	N	L	Y		E 2000			
481.04	493.88	506.72	516.68		47.88			

03-12-24 G:\0\Projects\T-245\T-Design_I-240-I-35 Phase IV - OK\CAD\T026-0903208-SPECIAL_SIGN_DETAILS_6_OF_10.dgn

Design	MSH	03-12-24
Drawn	CCC	03-12-24



SPECIAL SIGN DETAILS
6 OF 11

REVISIONS		
NO.	DESCRIPTION	DATE

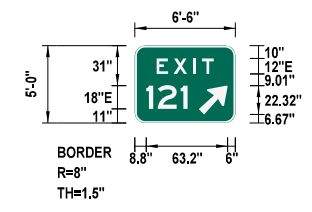

SPECIAL SIGN NO.	20
WIDTH x HGHT.	6'-6" x 5'-0"
BORDER WIDTH	1.5"
CORNER RADIUS	8"
MOUNTING	Ground
SIGN AREA	32.5 Sq.Ft.
BACKGROUND	TYPE: Reflective COLOR: Green
LEGENDBORDER	TYPE: Reflective COLOR: White

SYMBOL	X	Y	WID	HT
AR_Type A	49.66	6.67	17.99	28.35

Dimensions are in: Inches.tenths Letter locations are panel edge to lower left corner

LETTER POSITIONS (X)					LENGTH	SERIES / SIZE
E	X	I	T			E 2000
16.81	30.04	45.44	52.19		44.38	
1	2	1				E 2000
8.81	17.81	35.45			32.04	



SPECIAL SIGN NO.	21
WIDTH x HGHT.	16'-0" x 12'-6"
BORDER WIDTH	2"
CORNER RADIUS	12"
MOUNTING	Overhead
SIGN AREA	206.25 Sq.Ft.
BACKGROUND	TYPE: Reflective COLOR: Green
LEGENDBORDER	TYPE: Reflective COLOR: White

SYMBOL	X	Y	WID	HT
I-5	0	0	29.99	30
M1_1	41.61	97.28	45	36
ARDOWN	19.51	12.82	23.99	16.47
ARDOWN	148.5	12.82	23.99	16.47

Dimensions are in: Inches.tenths Letter locations are panel edge to lower left corner

LETTER POSITIONS (X)					LENGTH	SERIES / SIZE					
W	E	S	T			E 2000					
101.61	119.67	130.35	141.39		48.78						
L	a	w	t	o	n	EM 2000					
52.56	66.48	81.68	101.04	113.04	128.88	86.88					
S	E	6	6	t	h	S	t	EM 2000			
21.28	38.24	51.2	68.8	84.96	101.12	114.56	128.32	146.08	162.4	149.44	

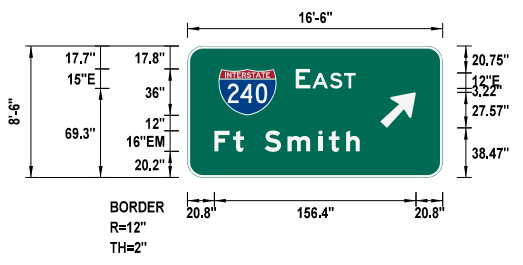

SPECIAL SIGN NO.	22
WIDTH x HGHT.	16'-6" x 8'-6"
BORDER WIDTH	2"
CORNER RADIUS	12"
MOUNTING	Overhead
SIGN AREA	140.25 Sq.Ft.
BACKGROUND	TYPE: Reflective COLOR: Green
LEGENDBORDER	TYPE: Reflective COLOR: White

SYMBOL	X	Y	WID	HT
M1_1	24.03	48.25	45	36
AR_Type A	149.62	38.47	22.23	35.01

Dimensions are in: Inches.tenths Letter locations are panel edge to lower left corner

LETTER POSITIONS (X)					LENGTH	SERIES / SIZE			
E	A	S	T			E 2000			
84.03	96.81	110.37	121.41		46.38				
F	t	S	m	i	t	h	EM 2000		
20.82	35.38	43.7	59.7	77.62	101.62	109.62	123.06	112.8	

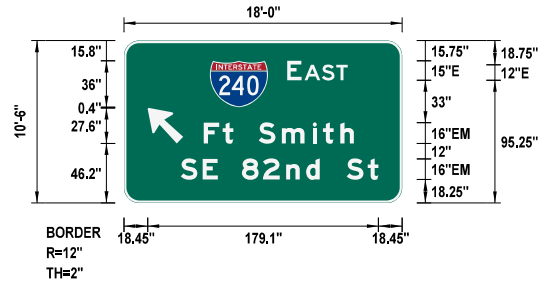

SPECIAL SIGN NO.	23
WIDTH x HGHT.	18'-0" x 10'-6"
BORDER WIDTH	2"
CORNER RADIUS	12"
MOUNTING	Overhead
SIGN AREA	189 Sq.Ft.
BACKGROUND	TYPE: Reflective COLOR: Green
LEGENDBORDER	TYPE: Reflective COLOR: White

SYMBOL	X	Y	WID	HT
M1_1	66.76	74.25	45	36
AR_Type A	18.46	46.25	22.23	35.02

Dimensions are in: Inches.tenths Letter locations are panel edge to lower left corner

LETTER POSITIONS (X)					LENGTH	SERIES / SIZE					
E	A	S	T			E 2000					
126.76	140.17	153.73	164.77		47.01						
F	t	S	m	i	t	h	EM 2000				
62.02	76.58	86.82	104.58	122.5	146.5	154.5	167.94	116.48			
S	E	8	2	n	d	S	t	EM 2000			
44.1	61.06	74.02	91.62	107.94	125.86	141.38	155.14	172.9	189.22	153.44	

03-12-24 G:\Projects\T-245\TE Design\I-240-I-35 Phase IV - OK\CAD\T027-0903208-SPECIAL SIGN DETAILS 7 OF 11.dgn

Design	MSH	03-12-24
Drawn	CCC	03-12-24



SPECIAL SIGN DETAILS
7 OF 11

REVISIONS		
NO.	DESCRIPTION	DATE

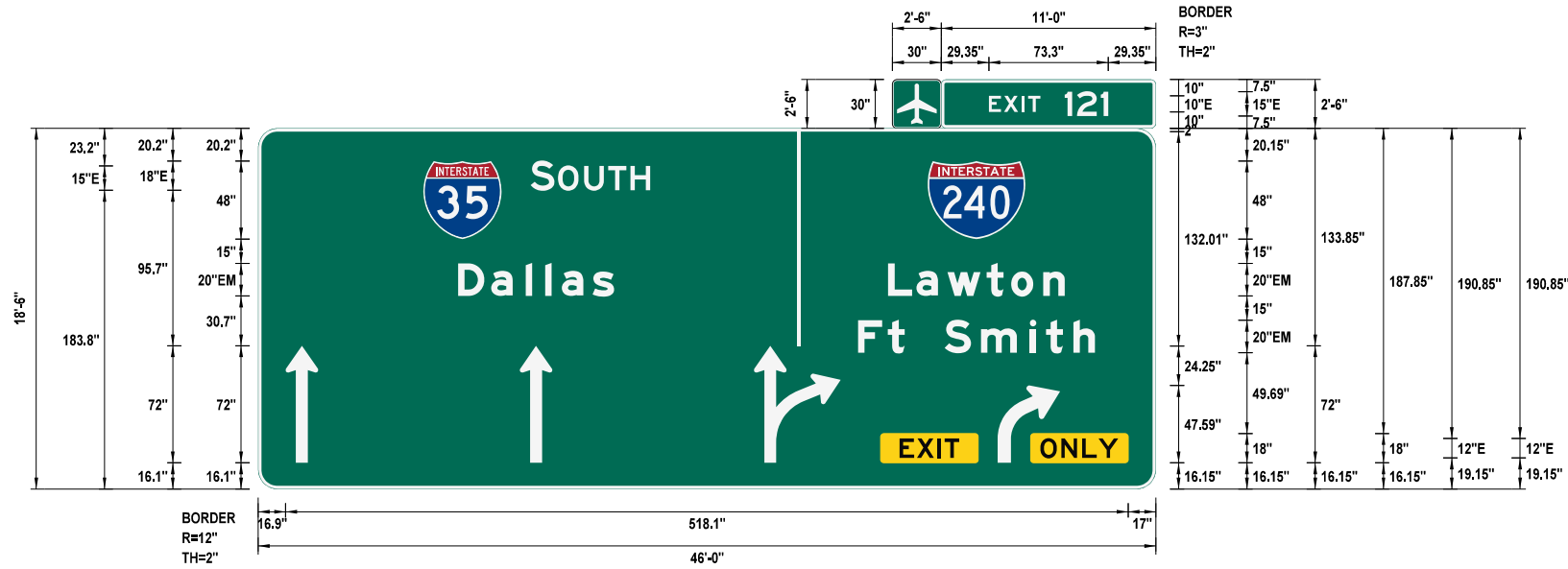

SPECIAL SIGN NO.	25
WIDTH x HIGHT	46'-0" x 18'-6"
BORDER WIDTH	2"
CORNER RADIUS	12"
MOUNTING	Overhead
SIGN AREA	884.76 Sq.Ft.
BACKGROUND	TYPE: Reflective COLOR: Green
LEGEND/BORDER	TYPE: Reflective COLOR: White

SYMBOL	X	Y	WD	HT
I-5	0	0	29.99	30
M1_1	101.57	153.85	48	48
M1_1	411.69	153.85	60	48
AR_THRU	16.89	16.15	19.99	72
AR_THRU	160.89	16.15	19.99	72
AR_THRU_RIGHT	304.89	16.15	53.32	72
AR_RIGHT_ONLY	454.78	16.15	38.34	47.59

Dimensions are in: inches,tenths

Letter locations are panel edge to lower left corner

LETTER POSITIONS (X)

		LENGTH		SERIES / SIZE				
E	X	I	T		E 2000			
29.34	38.58	49.62	53.47		31.63			
1	2	1			E 2000			
75.97	83.47	98.17			26.7			
S	O	U	T	H	E 2000			
167.57	184.4	200.45	215.15	228.95	73.53			
D	a	i	l	a	s	EM 2000		
122.88	143.28	164.48	176.48	186.68	205.68	96		
L	a	w	t	o	n	EM 2000		
387.39	404.79	423.79	447.99	462.99	482.79	108.6		
F	t	S	m	l	t	h	EM 2000	
368.89	387.09	399.89	422.09	444.49	474.49	484.49	501.29	145.6
E	X	I	T		E 2000			
394.42	405.1	417.94	422.14		36.72			
O	N	L	Y		E 2000			
481.04	493.88	506.72	516.68		47.88			

03-12-24 G:\Projects\T-245\T-245\Design\I-240-I-35 Phase IV - OK\CAD\T029-0903208-SPECIAL SIGN DETAILS 9 OF 11.dgn

Design	MSH	03-12-24
Drawn	CCC	03-12-24



SPECIAL SIGN DETAILS
9 OF 11

State Job No. 09032(08) Sheet No. T029

REVISIONS		
NO.	DESCRIPTION	DATE

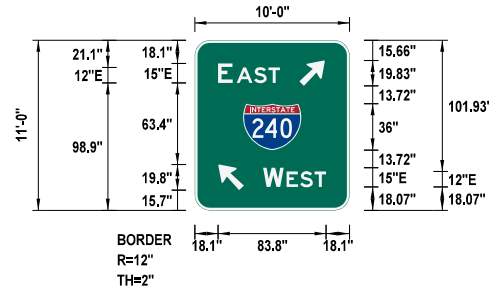

SPECIAL SIGN NO.	26
WIDTH x HGHT.	10'-0" x 11'-0"
BORDER WIDTH	2"
CORNER RADIUS	12"
MOUNTING	Ground
SIGN AREA	110 Sq.Ft.
BACKGROUND	TYPE: Reflective COLOR: Green
LEGENDBORDER	TYPE: Reflective COLOR: White

SYMBOL	X	Y	WID	HT
AR_Type A	81.1	96.51	15.99	25.19
M1_1	37.55	46.79	45	36
AR_Type A	18.19	15.66	15.99	25.19

Dimensions are in: Inches.tenths

Letter locations are panel edge to lower left corner

LETTER POSITIONS (X)										LENGTH	SERIES / SIZE
E	A	S	T							48	E 2000
18.1	32.5	46.06	57.1								
W	E	S	T							48.87	E 2000
53.03	71.18	81.86	92.9								

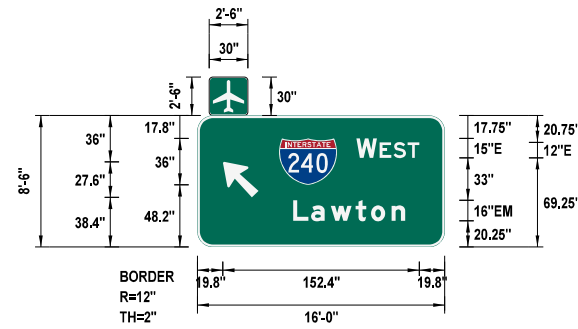

SPECIAL SIGN NO.	27
WIDTH x HGHT.	16'-0" x 8'-6"
BORDER WIDTH	2"
CORNER RADIUS	12"
MOUNTING	Overhead
SIGN AREA	142.25 Sq.Ft.
BACKGROUND	TYPE: Reflective COLOR: Green
LEGENDBORDER	TYPE: Reflective COLOR: White

SYMBOL	X	Y	WID	HT
I-5	0	0	29.99	30
M1_1	63.39	48.25	45	36
AR_Type A	19.83	38.47	22.23	35.01

Dimensions are in: Inches.tenths

Letter locations are panel edge to lower left corner

LETTER POSITIONS (X)										LENGTH	SERIES / SIZE
W	E	S	T							48.78	E 2000
123.39	141.45	152.13	163.17								
L	a	w	t	o	n					86.88	EM 2000
74.34	88.26	103.46	122.82	134.82	150.66						



SPECIAL SIGN NO.	28
WIDTH x HGHT.	15'-6" x 8'-0"
BORDER WIDTH	2"
CORNER RADIUS	12"
MOUNTING	Overhead
SIGN AREA	124 Sq.Ft.
BACKGROUND	TYPE: Reflective COLOR: Green
LEGENDBORDER	TYPE: Reflective COLOR: White

SYMBOL	X	Y	WID	HT
AR_Type A	78.66	20.22	22.23	35.02

Dimensions are in: Inches.tenths

Letter locations are panel edge to lower left corner

LETTER POSITIONS (X)										LENGTH	SERIES / SIZE
S	E	6	6	t	h	S	t			149.44	EM 2000
18.28	35.24	48.2	65.8	81.96	98.12	111.56	125.32	143.08	159.4		

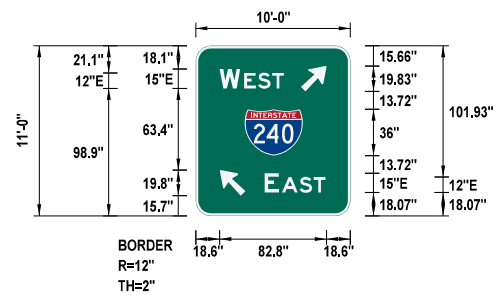

SPECIAL SIGN NO.	29
WIDTH x HGHT.	10'-0" x 11'-0"
BORDER WIDTH	2"
CORNER RADIUS	12"
MOUNTING	Ground
SIGN AREA	110 Sq.Ft.
BACKGROUND	TYPE: Reflective COLOR: Green
LEGENDBORDER	TYPE: Reflective COLOR: White

SYMBOL	X	Y	WID	HT
AR_Type A	81.58	96.51	15.99	25.19
M1_1	38.03	46.79	45	36
AR_Type A	18.67	15.66	15.99	25.19

Dimensions are in: Inches.tenths

Letter locations are panel edge to lower left corner

LETTER POSITIONS (X)										LENGTH	SERIES / SIZE
W	E	S	T							49.77	E 2000
18.58	37.63	48.31	59.35								
E	A	S	T							47.1	E 2000
53.51	67.01	80.57	91.61								

Design MSH 03-12-24
Drawn CCC 03-12-24



SPECIAL SIGN DETAILS
10 OF 11

State Job No. _09032(08) Sheet No. _T030

OKLAHOMA COUNTY

03-12-24 G:\0\Projects\T-245\TE Design\I-240-I-35 Phase IV - OK\CAD\T030-0903208-SPECIAL SIGN DETAILS 10 OF 11.dgn

REVISIONS		
NO.	DESCRIPTION	DATE

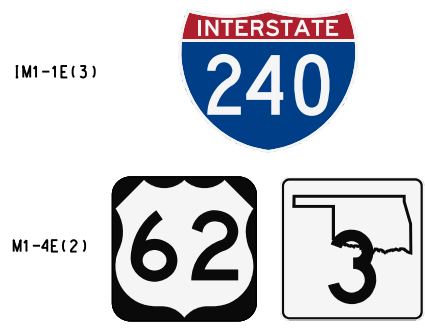

ROUTE ASSEMBLY NO. 1
29.25 S.F.

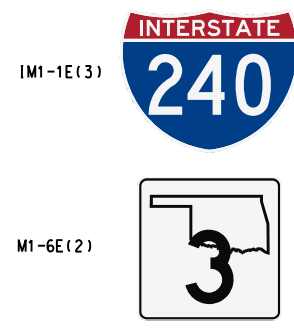

ROUTE ASSEMBLY NO. 2
20.25 S.F.

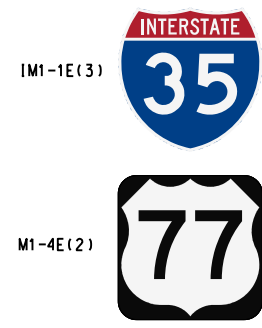

ROUTE ASSEMBLY NO. 3
18.00 S.F.



ROUTE ASSEMBLY NO. 4
27.00 S.F.

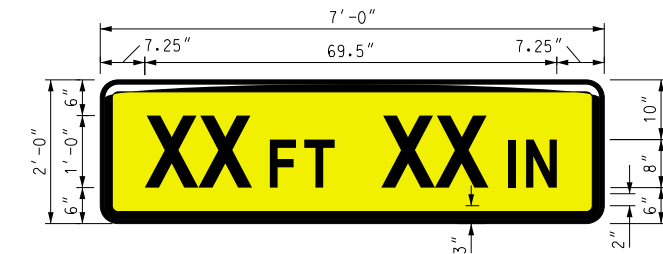

DETAIL OF VERTICAL CLEARANCE SIGN
W12-2o

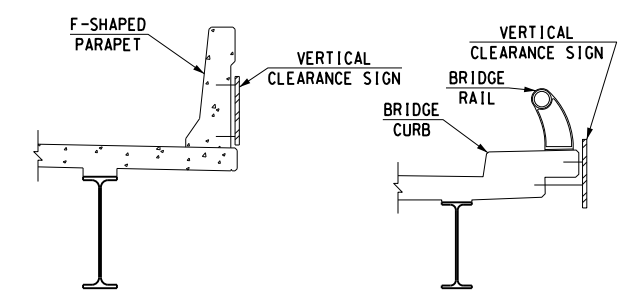

TYPICAL MOUNTING DETAIL

CONTRACTOR TO PROVIDE DETAIL FOR ATTACHMENT TO BRIDGE PARAPET OR CURB AND DECK TO ODOT FOR APPROVAL. SIGN SHALL BE ATTACHED AT A MINIMUM OF SIX LOCATIONS. COST SHALL BE INCLUDED IN THE CONTRACT UNIT PRICE OF "SHEET ALUMINUM SIGNS".

BRIDGE CLEARANCE SHALL BE FIELD VERIFIED BY THE CONTRACTOR. BRIDGE NUMBER SHALL ALSO BE VERIFIED BY THE CONTRACTOR.

03-12-24 G:\0\Projects\1-2457E Design\1-240-1-35 Phase IV - OK\CAD\T032-0903208-ROUTE ASSEMBLY AND VERTICAL CLEARANCE SIGNS.dgn

Design	MSH	03-12-24
Drawn	SB	03-12-24



REVISIONS		
NO.	DESCRIPTION	DATE

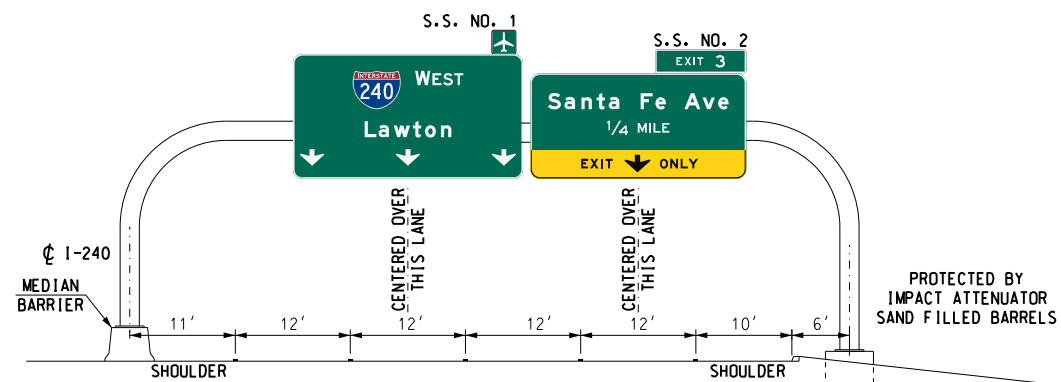

O.H. SIGN STRUCTURE NO. 1
75' TYPE "B" MONOTUBE
 CL I-240 WEST BOUND
 STA. 403+30
 (518.25 S.F.)

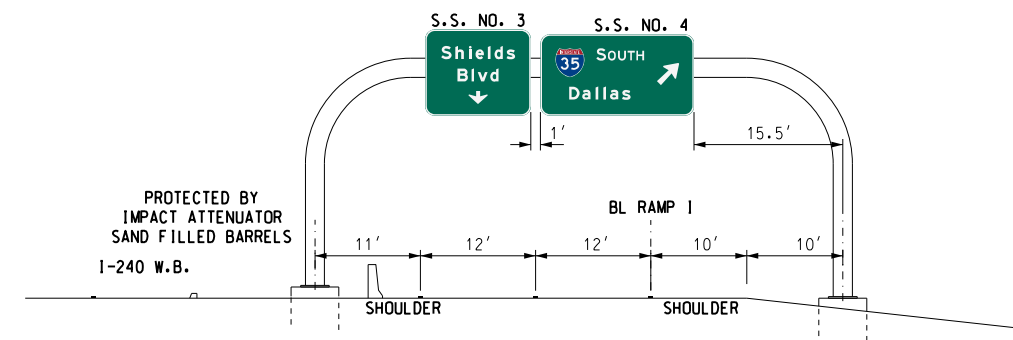

O.H. SIGN STRUCTURE NO. 2
55' TYPE "B" MONOTUBE
 BL RAMP L WEST BOUND
 STA. 425+40
 (235.00 S.F.)

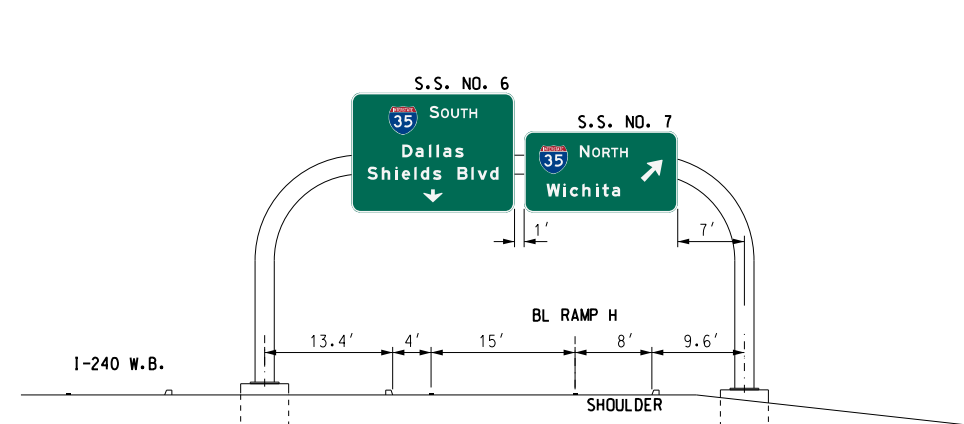

O.H. SIGN STRUCTURE NO. 3
55' TYPE "B" MONOTUBE
 BL RAMP H WEST BOUND
 STA. 439+54
 (348.50 S.F.)

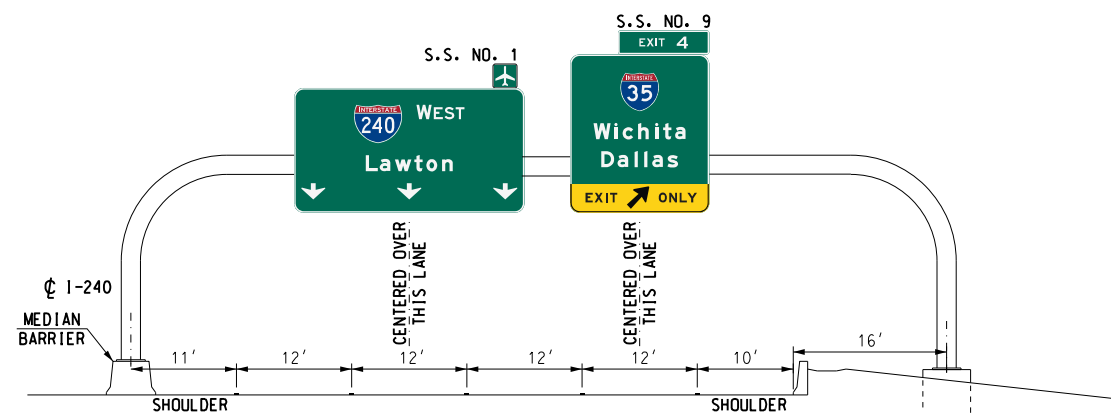

O.H. SIGN STRUCTURE NO. 4
75' TYPE "B" MONOTUBE
 CL I-240 WEST BOUND
 STA. 451+00
 (581.25 S.F.)

03-12-24 G:\01\Projects\1-245\TE Design\1-240-I-35 Phase IV - OKLA\CAD\T033-090320B-SIGN STRUCTURE DETAILS.T033.dgn

Design	MSH	03-12-24
Drawn	SB	03-12-24
TEC A CLEAR DIRECTION		

REVISIONS		
NO.	DESCRIPTION	DATE

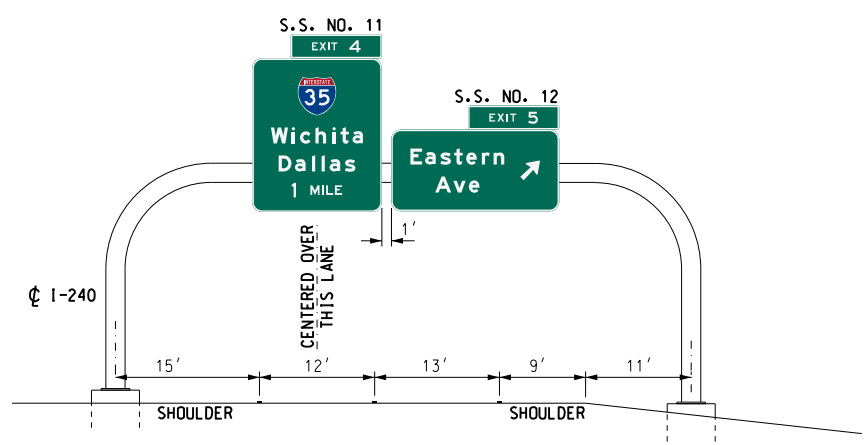

O.H. SIGN STRUCTURE NO. 5
60' TYPE "B" MONOTUBE
 CL I-240 WEST BOUND
 STA. 496+00
 (412.25 S.F.)

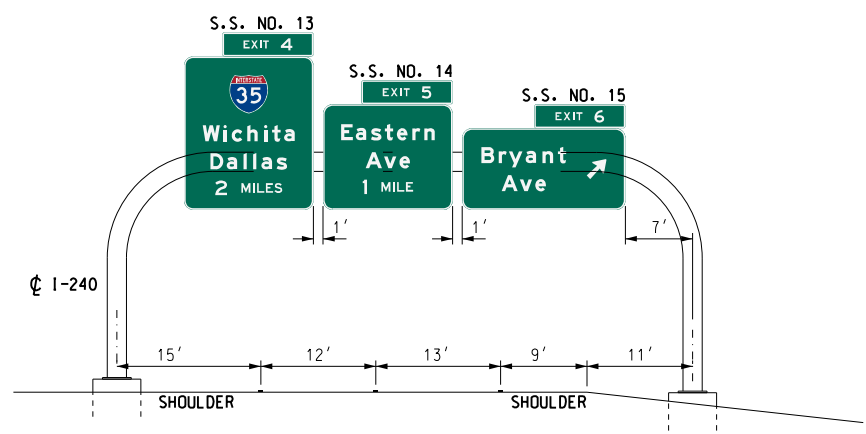

O.H. SIGN STRUCTURE NO. 6
60' TYPE "B" MONOTUBE
 CL I-240 WEST BOUND
 STA. 496+00
 (580.25 S.F.)

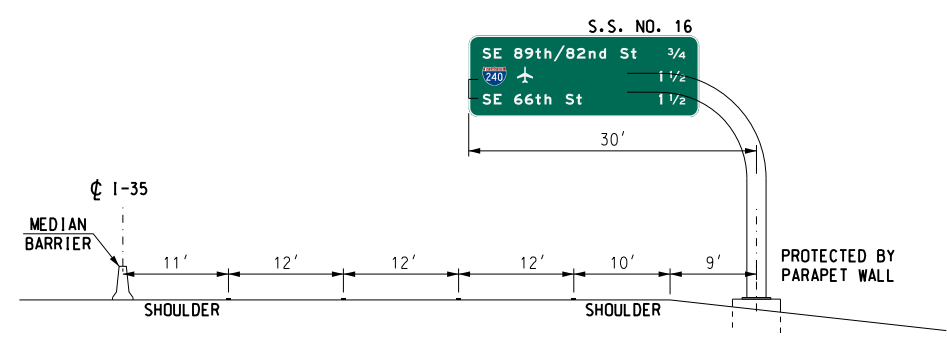

O.H. SIGN STRUCTURE
EXIST. TYPE "C" MONOTUBE
 CL I-35 NORTH BOUND
 APPROX. 540' N. OF N.W. 27th ST.
 (204.00 S.F.)

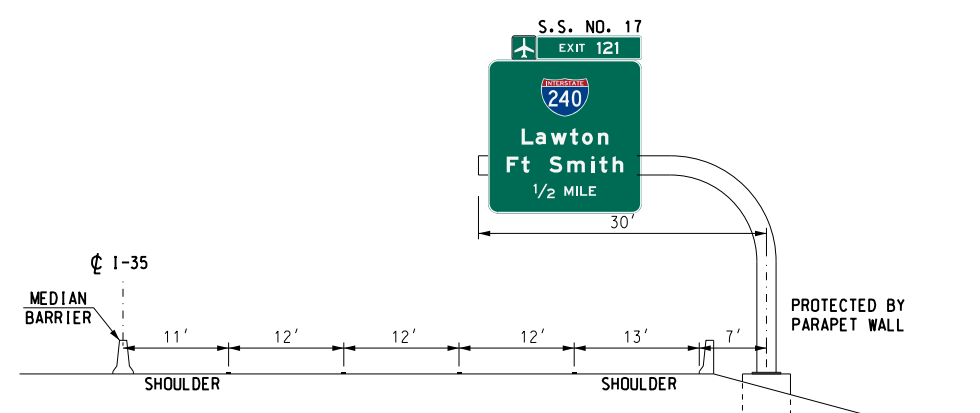

O.H. SIGN STRUCTURE NO. 7
TYPE "C" MONOTUBE
 CL I-35 NORTH BOUND
 STA. 30+17
 (287.75 S.F.)

G:\01\Projects\1-245\TE Design\I-240-I-35 Phase IV - OKLA CAD\T034-0903208-SIGN STRUCTURE DETAILS 2 OF 3.dgn 03-12-24

Design	MSH	03-12-24
Drawn	SB	03-12-24

SIGN STRUCTURE DETAILS
(2 OF 3)

State Job No. 09032(08) Sheet No. T034

OKLAHOMA COUNTY

REVISIONS		
NO.	DESCRIPTION	DATE

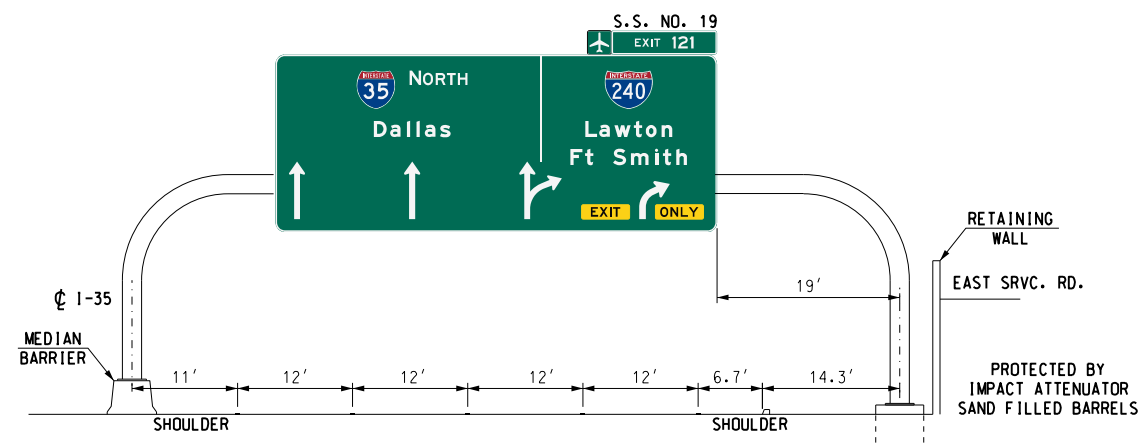

O.H. SIGN STRUCTURE
 EXIST. 80' TYPE "B" MONOTUBE
 CL I-35 NORTH BOUND
 STA. 52+70
 (884.75 S.F.)

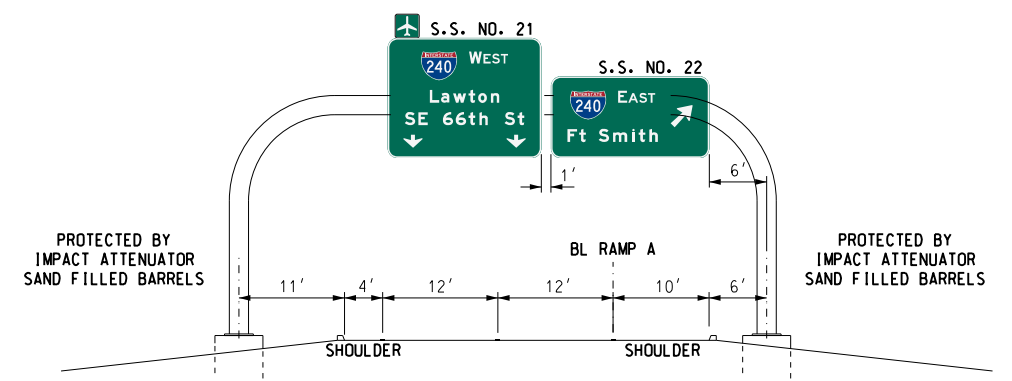

O.H. SIGN STRUCTURE NO. 8
 55' TYPE "B" MONOTUBE
 BL RAMP A NORTH BOUND
 STA. 65+65
 (346.50 S.F.)

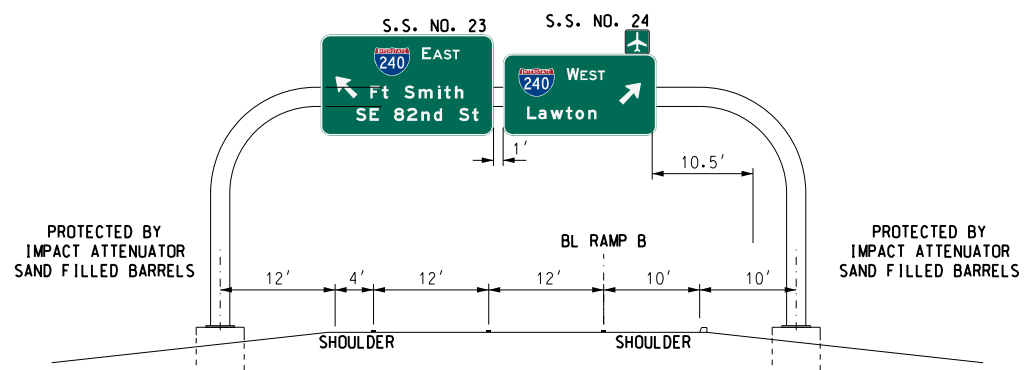

O.H. SIGN STRUCTURE
 EXIST. 60' TYPE "B" MONOTUBE
 BL RAMP B SOUTH BOUND
 STA. 406+33
 (331.25 S.F.)

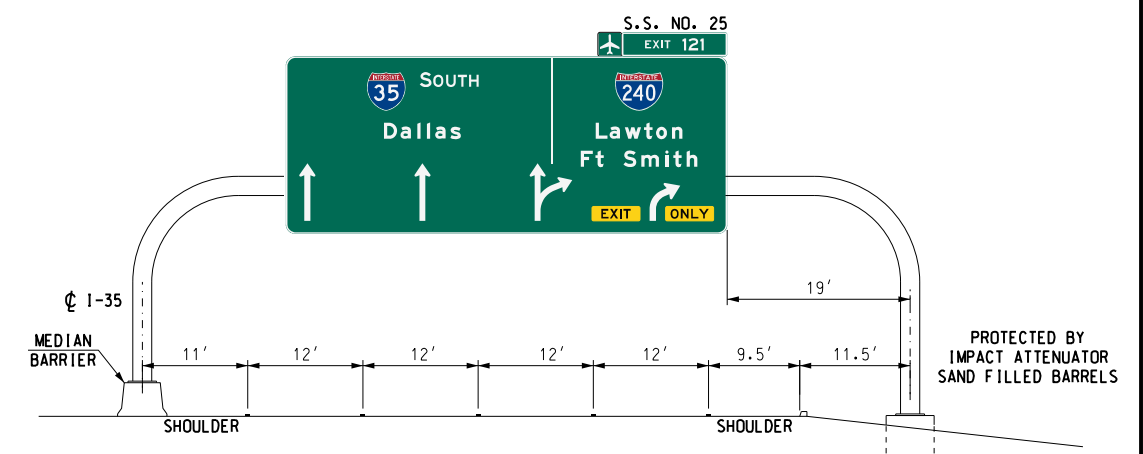

O.H. SIGN STRUCTURE
 EXIST. 80' TYPE "B" MONOTUBE
 CL I-35 SOUTH BOUND
 STA. 395+08
 (884.75 S.F.)

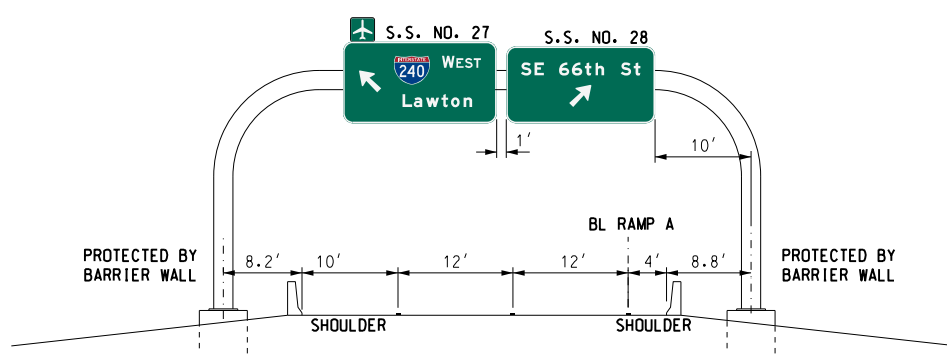

O.H. SIGN STRUCTURE NO. 9
 55' TYPE "B" MONOTUBE
 BL RAMP A SOUTH BOUND
 STA. 72+85
 (266.25 S.F.)

03-12-24 G:\V\Projects\1-2457E Design\1-240-I-35 Phase IV - OK\CAD\T035-0903208-SIGN STRUCTURE DETAILS 3 OF 3.dgn

Design	MSH	03-12-24
Drawn	SB	03-12-24
TEC A CLEAR DIRECTION		

SIGN STRUCTURE DETAILS
(3 OF 3)

State Job No. 09032(08) Sheet No. T035
 OKLAHOMA COUNTY

03-12-24 G:\V\Projects\1-2457E Design\1-240-1-35 Phase IV - OKC\CAD\T036-0903208-SIGNING & STRIPING SHEET LAYOUT MAP.dgn

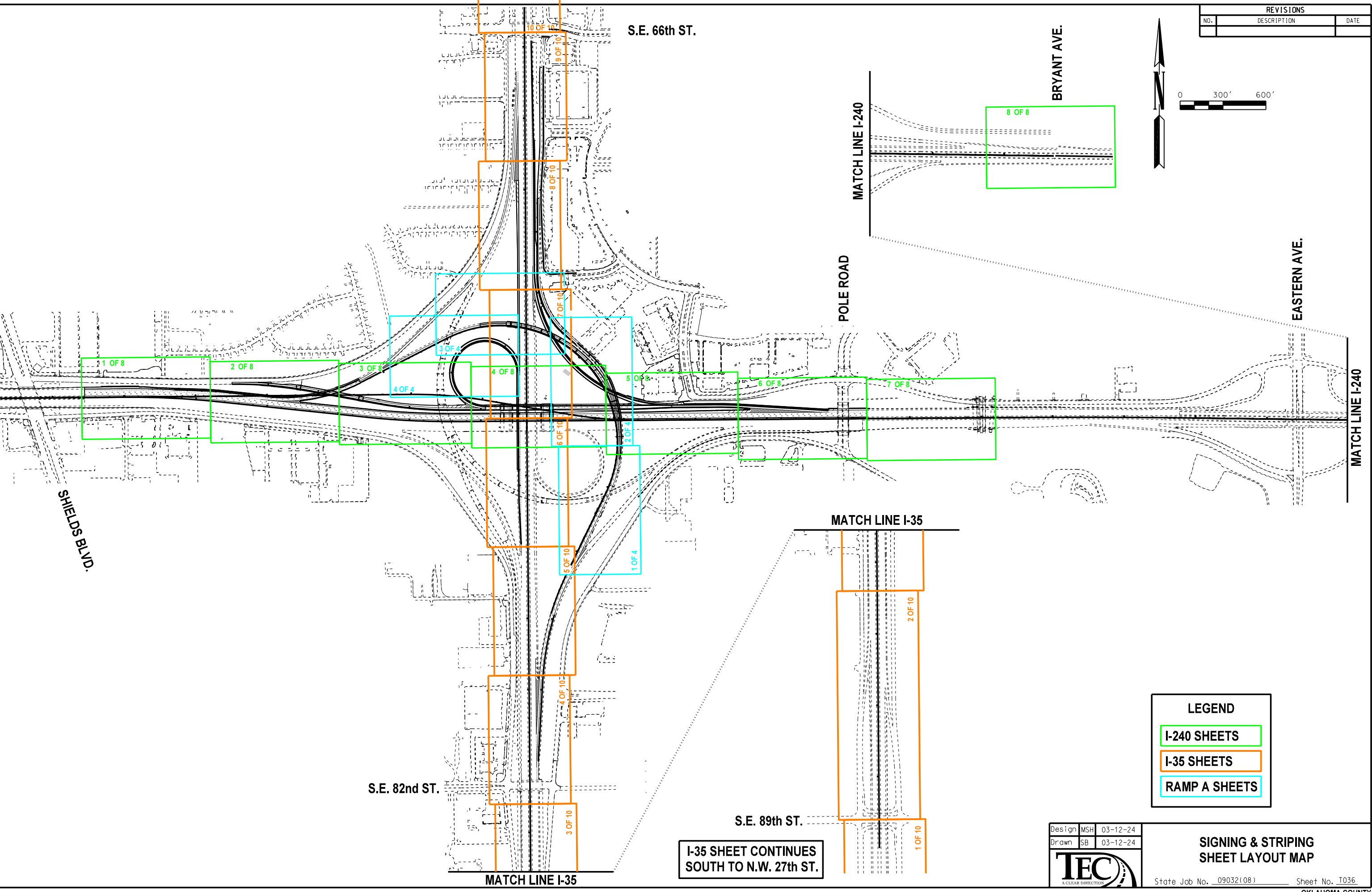

REVISIONS		
NO.	DESCRIPTION	DATE

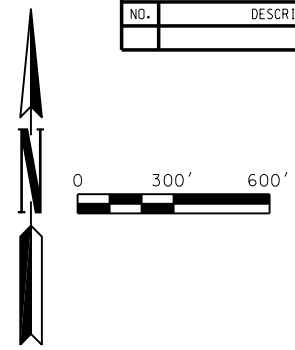

LEGEND	
 	I-240 SHEETS
 	I-35 SHEETS
 	RAMP A SHEETS

Design	MSH	03-12-24
Drawn	SB	03-12-24
TEC A CLEAR DIRECTION		

**SIGNING & STRIPING
SHEET LAYOUT MAP**

State Job No. _09032(08) Sheet No. _T036_

OKLAHOMA COUNTY

**I-35 SHEET CONTINUES
SOUTH TO N.W. 27th ST.**

REVISIONS		
NO.	DESCRIPTION	DATE

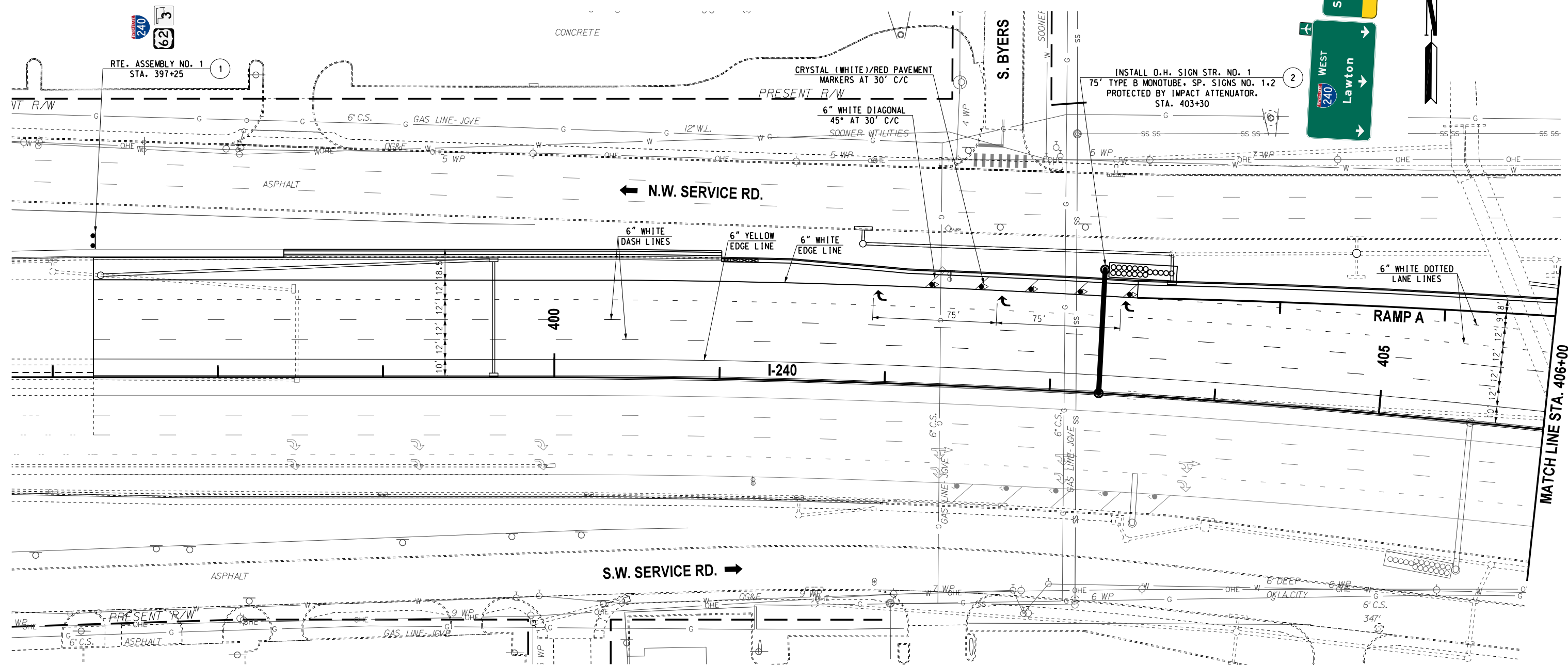
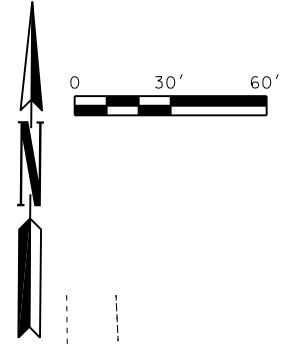

MULTI-POLY STRIPING SUMMARY TABLE

DESCRIPTION	UNIT	TOTALS
TRAFFIC STRIPE (MULTI-POLY) 4" WHITE	L.F.	0
TRAFFIC STRIPE (MULTI-POLY) 4" YELLOW	L.F.	0
TRAFFIC STRIPE (MULTI-POLY) 4" BLACK	L.F.	0
TRAFFIC STRIPE (MULTI-POLY) 6" WHITE	L.F.	1166
TRAFFIC STRIPE (MULTI-POLY) 6" YELLOW	L.F.	875
TRAFFIC STRIPE (MULTI-POLY) 6" BLACK	L.F.	0
TRAFFIC STRIPE (MULTI-POLY) 8" WHITE	L.F.	0
TRAFFIC STRIPE (MULTI-POLY) 8" YELLOW	L.F.	0
TRAFFIC STRIPE (MULTI-POLY) 8" BLACK	L.F.	0
TRAFFIC STRIPE (MULTI-POLY) 12" WHITE	L.F.	0
TRAFFIC STRIPE (MULTI-POLY) 12" YELLOW	L.F.	0
TRAFFIC STRIPE (MULTI-POLY) 12" BLACK	L.F.	0
TRAFFIC STRIPE (MULTI-POLY) 24" WHITE	L.F.	0
TRAFFIC STRIPE (MULTI-POLY) ARROWS	EA.	0
TRAFFIC STRIPE (MULTI-POLY) WORDS	EA.	0
TRAFFIC STRIPE (MULTI-POLY) SYMBOLS	EA.	0

CLASS A, TYPE 2 PAVEMENT MARKER / DELINEATOR SUMMARY TABLE

DESCRIPTION	UNIT	TOTALS
◊ COLOR A - CRYSTAL/CRYSTAL (WHITE/WHITE)	EA.	0
◊ COLOR C - CRYSTAL/RED (WHITE/RED)	EA.	5
◊ COLOR D - AMBER/AMBER (YELLOW/YELLOW)	EA.	0
◊ COLOR E - AMBER/RED (YELLOW/RED)	EA.	0
— TYPE 1 - FLEXIBLE DRIVEABLE DELINEATOR	EA.	0

FOR MORE INFORMATION ON RAISED PAVEMENT MARKERS AND DELINEATORS, SEE TYPICAL DETAIL SHEETS.



CONTRACTOR TO REMOVE ALL CONFLICTING STRIPING.

Design MSH 03-12-24
Drawn SB 03-12-24



I-240 SIGNING & STRIPING
1 OF 8

03-12-24 G:\V\Projects\I-240\I-240-1-35 Phase IV - OKLA CAD\I037-0903208-I240 SIGNING & STRIPING PLAN I0F 8.dgn

REVISIONS		
NO.	DESCRIPTION	DATE

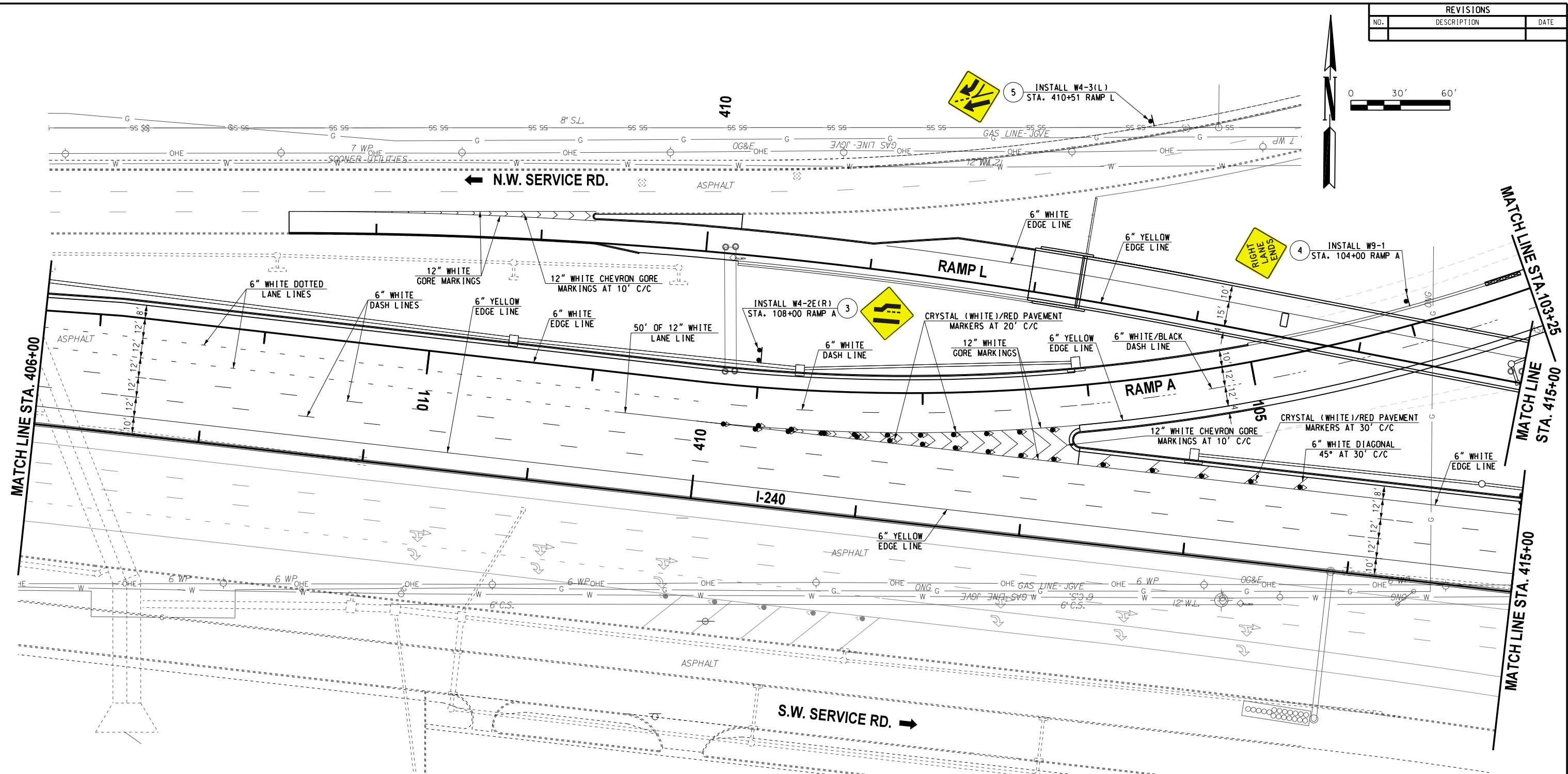
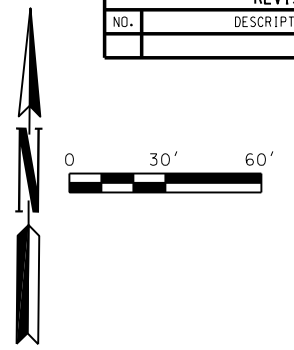

MULTI-POLY STRIPING SUMMARY TABLE

DESCRIPTION	UNIT	TOTALS
TRAFFIC STRIPE (MULTI-POLY) 4" WHITE	L.F.	0
TRAFFIC STRIPE (MULTI-POLY) 4" YELLOW	L.F.	0
TRAFFIC STRIPE (MULTI-POLY) 4" BLACK	L.F.	0
TRAFFIC STRIPE (MULTI-POLY) 6" WHITE	L.F.	3520
TRAFFIC STRIPE (MULTI-POLY) 6" YELLOW	L.F.	2000
TRAFFIC STRIPE (MULTI-POLY) 6" BLACK	L.F.	100
TRAFFIC STRIPE (MULTI-POLY) 8" WHITE	L.F.	0
TRAFFIC STRIPE (MULTI-POLY) 8" YELLOW	L.F.	0
TRAFFIC STRIPE (MULTI-POLY) 8" BLACK	L.F.	0
TRAFFIC STRIPE (MULTI-POLY) 12" WHITE	L.F.	3000
TRAFFIC STRIPE (MULTI-POLY) 12" YELLOW	L.F.	0
TRAFFIC STRIPE (MULTI-POLY) 12" BLACK	L.F.	0
TRAFFIC STRIPE (MULTI-POLY) 24" WHITE	L.F.	0
TRAFFIC STRIPE (MULTI-POLY) ARROWS	EA.	0
TRAFFIC STRIPE (MULTI-POLY) WORDS	EA.	0
TRAFFIC STRIPE (MULTI-POLY) SYMBOLS	EA.	0

CLASS A, TYPE 2 PAVEMENT MARKER / DELINEATOR SUMMARY TABLE

DESCRIPTION	UNIT	TOTALS
◊ COLOR A - CRYSTAL/CRYSTAL (WHITE/WHITE)	EA.	0
◊ COLOR C - CRYSTAL/RED (WHITE/RED)	EA.	30
◊ COLOR D - AMBER/AMBER (YELLOW/YELLOW)	EA.	0
◊ COLOR E - AMBER/RED (YELLOW/RED)	EA.	0
— TYPE 1 - FLEXIBLE DRIVEABLE DELINEATOR	EA.	0

FOR MORE INFORMATION ON RAISED PAVEMENT MARKERS AND DELINEATORS, SEE TYPICAL DETAIL SHEETS.



CONTRACTOR TO REMOVE ALL CONFLICTING STRIPING.

Design	MSH	03-12-24
Drawn	SB	03-12-24



I-240 SIGNING & STRIPING
2 OF 8

03-12-24 G:\V\Projects\I-240\Design\I-240-1-35 Phase IV - OKLA CAD\T038-0903208-1240 SIGNING & STRIPING PLAN 2 OF 8.dgn

REVISIONS		
NO.	DESCRIPTION	DATE

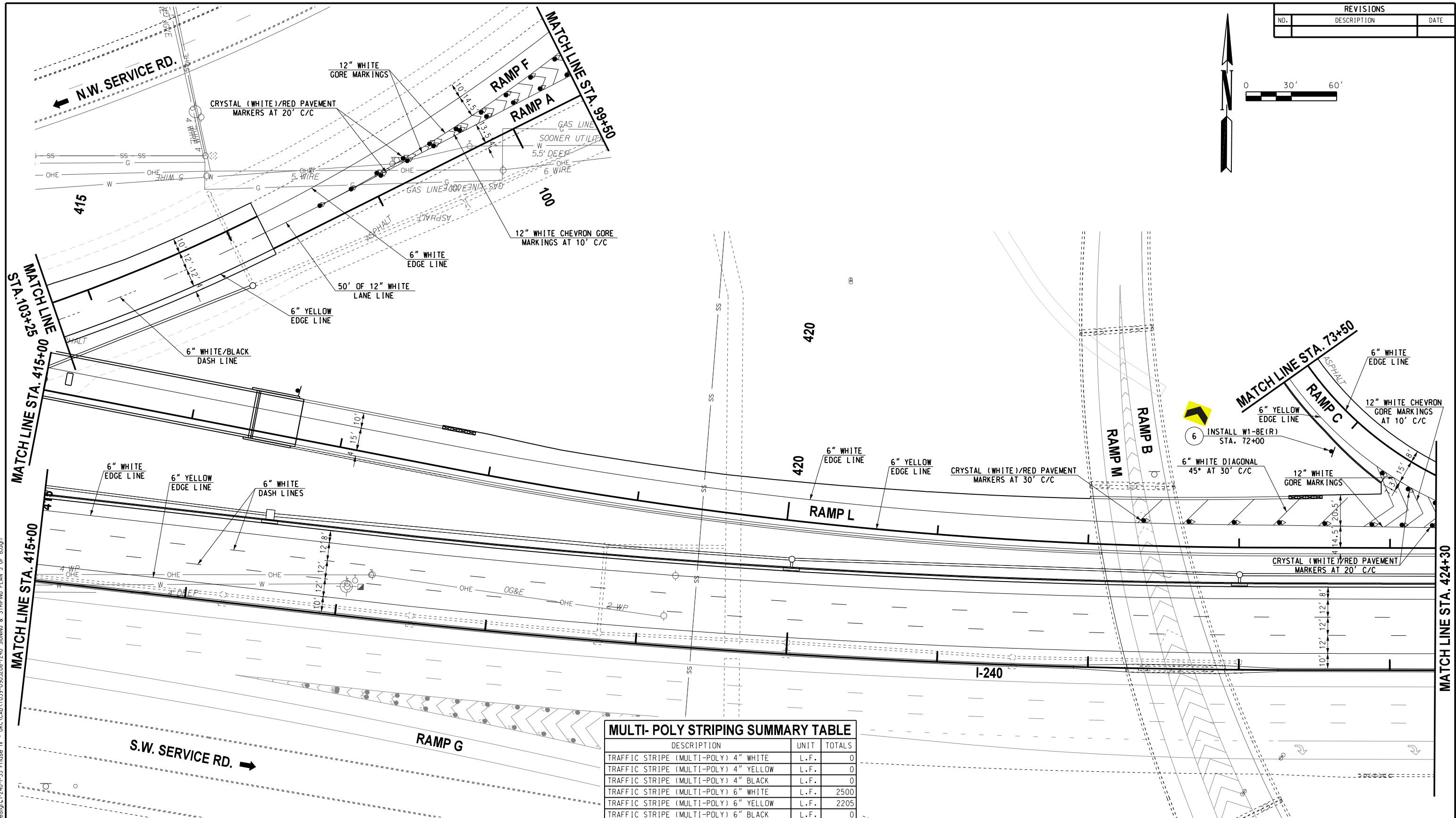
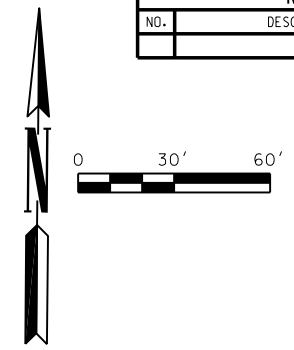

MULTI-POLY STRIPING SUMMARY TABLE

DESCRIPTION	UNIT	TOTALS
TRAFFIC STRIPE (MULTI-POLY) 4" WHITE	L.F.	0
TRAFFIC STRIPE (MULTI-POLY) 4" YELLOW	L.F.	0
TRAFFIC STRIPE (MULTI-POLY) 4" BLACK	L.F.	0
TRAFFIC STRIPE (MULTI-POLY) 6" WHITE	L.F.	2500
TRAFFIC STRIPE (MULTI-POLY) 6" YELLOW	L.F.	2205
TRAFFIC STRIPE (MULTI-POLY) 6" BLACK	L.F.	0
TRAFFIC STRIPE (MULTI-POLY) 8" WHITE	L.F.	0
TRAFFIC STRIPE (MULTI-POLY) 8" YELLOW	L.F.	0
TRAFFIC STRIPE (MULTI-POLY) 8" BLACK	L.F.	0
TRAFFIC STRIPE (MULTI-POLY) 12" WHITE	L.F.	800
TRAFFIC STRIPE (MULTI-POLY) 12" YELLOW	L.F.	0
TRAFFIC STRIPE (MULTI-POLY) 12" BLACK	L.F.	0
TRAFFIC STRIPE (MULTI-POLY) 24" WHITE	L.F.	0
TRAFFIC STRIPE (MULTI-POLY) ARROWS	EA.	0
TRAFFIC STRIPE (MULTI-POLY) WORDS	EA.	0
TRAFFIC STRIPE (MULTI-POLY) SYMBOLS	EA.	0

CLASS A, TYPE 2 PAVEMENT MARKER / DELINEATOR SUMMARY TABLE

DESCRIPTION	UNIT	TOTALS
◊ COLOR A - CRYSTAL/CRYSTAL (WHITE/WHITE)	EA.	0
◊ COLOR C - CRYSTAL/RED (WHITE/RED)	EA.	30
◊ COLOR D - AMBER/AMBER (YELLOW/YELLOW)	EA.	0
◊ COLOR E - AMBER/RED (YELLOW/RED)	EA.	0
— TYPE 1 - FLEXIBLE DRIVEABLE DELINEATOR	EA.	0

FOR MORE INFORMATION ON RAISED PAVEMENT MARKERS AND DELINEATORS, SEE TYPICAL DETAIL SHEETS.



CONTRACTOR TO REMOVE ALL CONFLICTING STRIPING.

Design MSH 03-12-24
Drawn SB 03-12-24



I-240 SIGNING & STRIPING
3 OF 8

03-12-24 G:\V\Projects\I-240\1-35 Phase IV - OKLA CAD\T039-0903208-1240 SIGNING & STRIPING PLAN 3 OF 8.dgn

REVISIONS		
NO.	DESCRIPTION	DATE

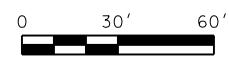

INSTALL O.H. SIGN STR. NO. 2
55' TYPE B MONOTUBE, SP. SIGNS NO. 3, 4
AND W13-7E(25) MOUNTED ON POLE SHAFT
PROTECTED BY TWO IMPACT ATTENUATOR.
STA. 425+40 RAMP L

REMOVE EXISTING
O.H. SIGN STRUCTURE

CRYSTAL (WHITE)/RED PAVEMENT
MARKERS AT 20' C/C

12" WHITE CHEVRON
GORE MARKINGS
AT 10' C/C

6" WHITE DIAGONAL
45° AT 30' C/C

CRYSTAL (WHITE)/RED PAVEMENT
MARKERS AT 30' C/C

12" WHITE
GORE MARKINGS

RAMP C

RAMP I

6" WHITE
EDGE LINES

6" YELLOW
EDGE LINES

6" WHITE/BLACK
DASH LINE

6" WHITE
DASH LINES

MATCH LINE STA. 424+30

MATCH LINE STA. 433+65

MULTI-POLY STRIPING SUMMARY TABLE

DESCRIPTION	UNIT	TOTALS
TRAFFIC STRIPE (MULTI-POLY) 4" WHITE	L.F.	0
TRAFFIC STRIPE (MULTI-POLY) 4" YELLOW	L.F.	0
TRAFFIC STRIPE (MULTI-POLY) 4" BLACK	L.F.	0
TRAFFIC STRIPE (MULTI-POLY) 6" WHITE	L.F.	2600
TRAFFIC STRIPE (MULTI-POLY) 6" YELLOW	L.F.	2000
TRAFFIC STRIPE (MULTI-POLY) 6" BLACK	L.F.	300
TRAFFIC STRIPE (MULTI-POLY) 8" WHITE	L.F.	0
TRAFFIC STRIPE (MULTI-POLY) 8" YELLOW	L.F.	0
TRAFFIC STRIPE (MULTI-POLY) 8" BLACK	L.F.	0
TRAFFIC STRIPE (MULTI-POLY) 12" WHITE	L.F.	0
TRAFFIC STRIPE (MULTI-POLY) 12" YELLOW	L.F.	500
TRAFFIC STRIPE (MULTI-POLY) 12" BLACK	L.F.	0
TRAFFIC STRIPE (MULTI-POLY) 24" WHITE	L.F.	0
TRAFFIC STRIPE (MULTI-POLY) ARROWS	EA.	0
TRAFFIC STRIPE (MULTI-POLY) WORDS	EA.	0
TRAFFIC STRIPE (MULTI-POLY) SYMBOLS	EA.	0

**CLASS A, TYPE 2 PAVEMENT MARKER /
DELINEATOR SUMMARY TABLE**

DESCRIPTION	UNIT	TOTALS
◊ COLOR A - CRYSTAL/CRYSTAL (WHITE/WHITE)	EA.	0
◊ COLOR C - CRYSTAL/RED (WHITE/RED)	EA.	11
◊ COLOR D - AMBER/AMBER (YELLOW/YELLOW)	EA.	0
◊ COLOR E - AMBER/RED (YELLOW/RED)	EA.	0
— TYPE 1 - FLEXIBLE DRIVEABLE DELINEATOR	EA.	0

**FOR MORE INFORMATION ON
RAISED PAVEMENT MARKERS
AND DELINEATORS, SEE
TYPICAL DETAIL SHEETS.**

**CONTRACTOR TO REMOVE
ALL CONFLICTING STRIPING.**

Design MSH 03-12-24
Drawn SB 03-12-24



**I-240 SIGNING & STRIPING
4 OF 8**

State Job No. _09032(08) Sheet No. _I040_

OKLAHOMA COUNTY

03-12-24 G:\0\Projects\T-245\I-240-I-35 Phase IV - OKLAHOMA COUNTY DESIGN - I-240-I-35 Phase IV - SIGNING & STRIPING PLAN 4 OF 8.dgn



REVISIONS		
NO.	DESCRIPTION	DATE

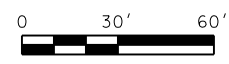

9 INSTALL O.H. SIGN STR. NO. 3
50' TYPE B MONOTUBE, SP. SIGNS NO. 6.7
PROTECTED BY 2 IMPACT ATTENUATORS.
STA. 439+54, RAMP H

8 SPECIAL SIGN NO. 5
STA. 435+50 (RAMP H)

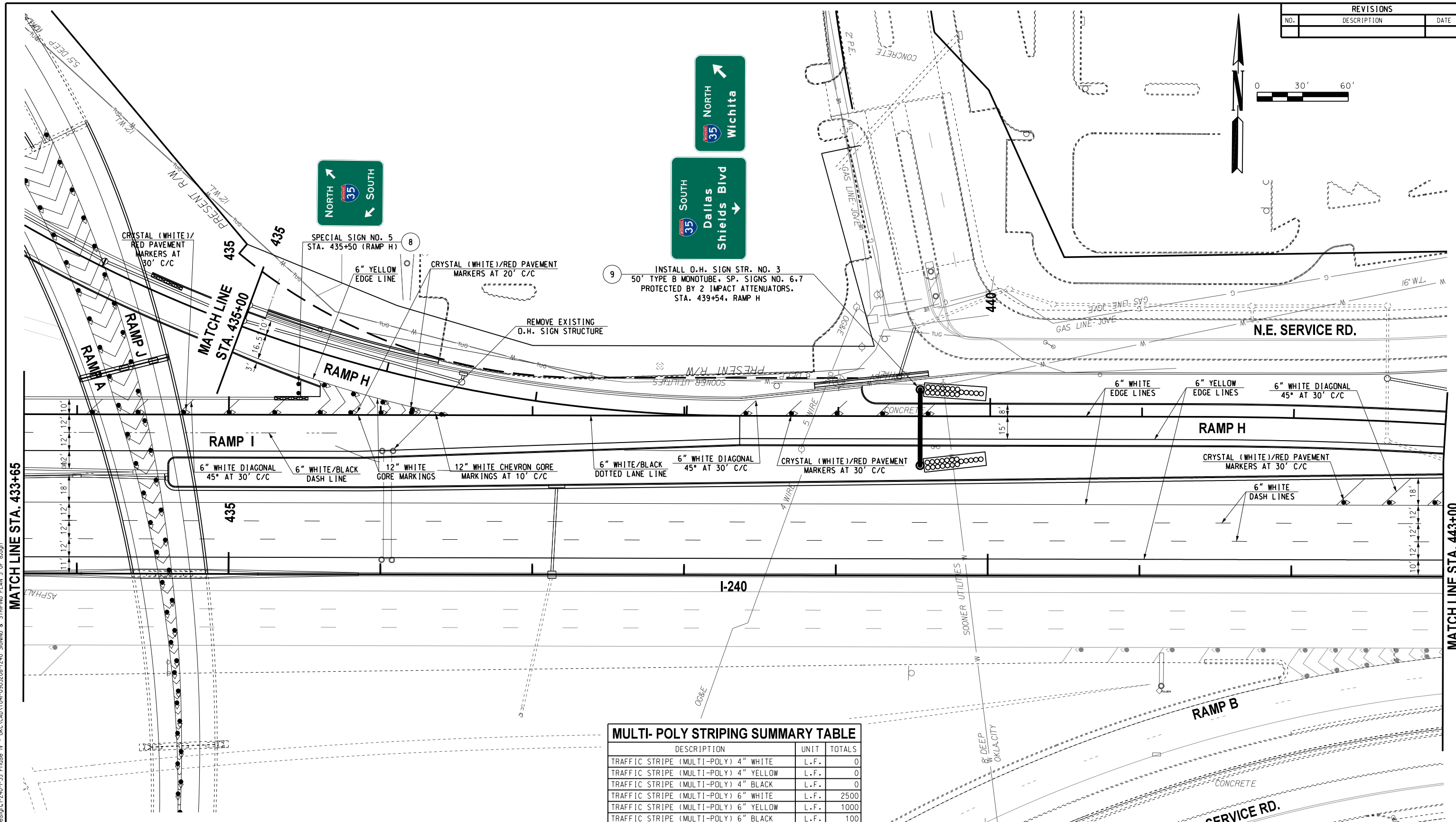

MULTI-POLY STRIPING SUMMARY TABLE

DESCRIPTION	UNIT	TOTALS
TRAFFIC STRIPE (MULTI-POLY) 4" WHITE	L.F.	0
TRAFFIC STRIPE (MULTI-POLY) 4" YELLOW	L.F.	0
TRAFFIC STRIPE (MULTI-POLY) 4" BLACK	L.F.	0
TRAFFIC STRIPE (MULTI-POLY) 6" WHITE	L.F.	2500
TRAFFIC STRIPE (MULTI-POLY) 6" YELLOW	L.F.	1000
TRAFFIC STRIPE (MULTI-POLY) 6" BLACK	L.F.	100
TRAFFIC STRIPE (MULTI-POLY) 8" WHITE	L.F.	0
TRAFFIC STRIPE (MULTI-POLY) 8" YELLOW	L.F.	0
TRAFFIC STRIPE (MULTI-POLY) 8" BLACK	L.F.	0
TRAFFIC STRIPE (MULTI-POLY) 12" WHITE	L.F.	2000
TRAFFIC STRIPE (MULTI-POLY) 12" YELLOW	L.F.	0
TRAFFIC STRIPE (MULTI-POLY) 12" BLACK	L.F.	0
TRAFFIC STRIPE (MULTI-POLY) 24" WHITE	L.F.	0
TRAFFIC STRIPE (MULTI-POLY) ARROWS	EA.	0
TRAFFIC STRIPE (MULTI-POLY) WORDS	EA.	0
TRAFFIC STRIPE (MULTI-POLY) SYMBOLS	EA.	0

CLASS A, TYPE 2 PAVEMENT MARKER / DELINEATOR SUMMARY TABLE

DESCRIPTION	UNIT	TOTALS
◊ COLOR A - CRYSTAL/CRYSTAL (WHITE/WHITE)	EA.	0
◊ COLOR C - CRYSTAL/RED (WHITE/RED)	EA.	22
◊ COLOR D - AMBER/AMBER (YELLOW/YELLOW)	EA.	0
◊ COLOR E - AMBER/RED (YELLOW/RED)	EA.	0
▬ TYPE 1 - FLEXIBLE DRIVEABLE DELINEATOR	EA.	0

FOR MORE INFORMATION ON RAISED PAVEMENT MARKERS AND DELINEATORS, SEE TYPICAL DETAIL SHEETS.



CONTRACTOR TO REMOVE ALL CONFLICTING STRIPING.

Design MSH 03-12-24
Drawn SB 03-12-24



I-240 SIGNING & STRIPING
5 OF 8

03-12-24 G:\VOP\Projects\T-2457E Design, I-240-I-35 Phase IV - OKLA CAD\T041-0903208-I-240_SIGNING & STRIPING PLAN 5 OF 8.dgn

REVISIONS		
NO.	DESCRIPTION	DATE

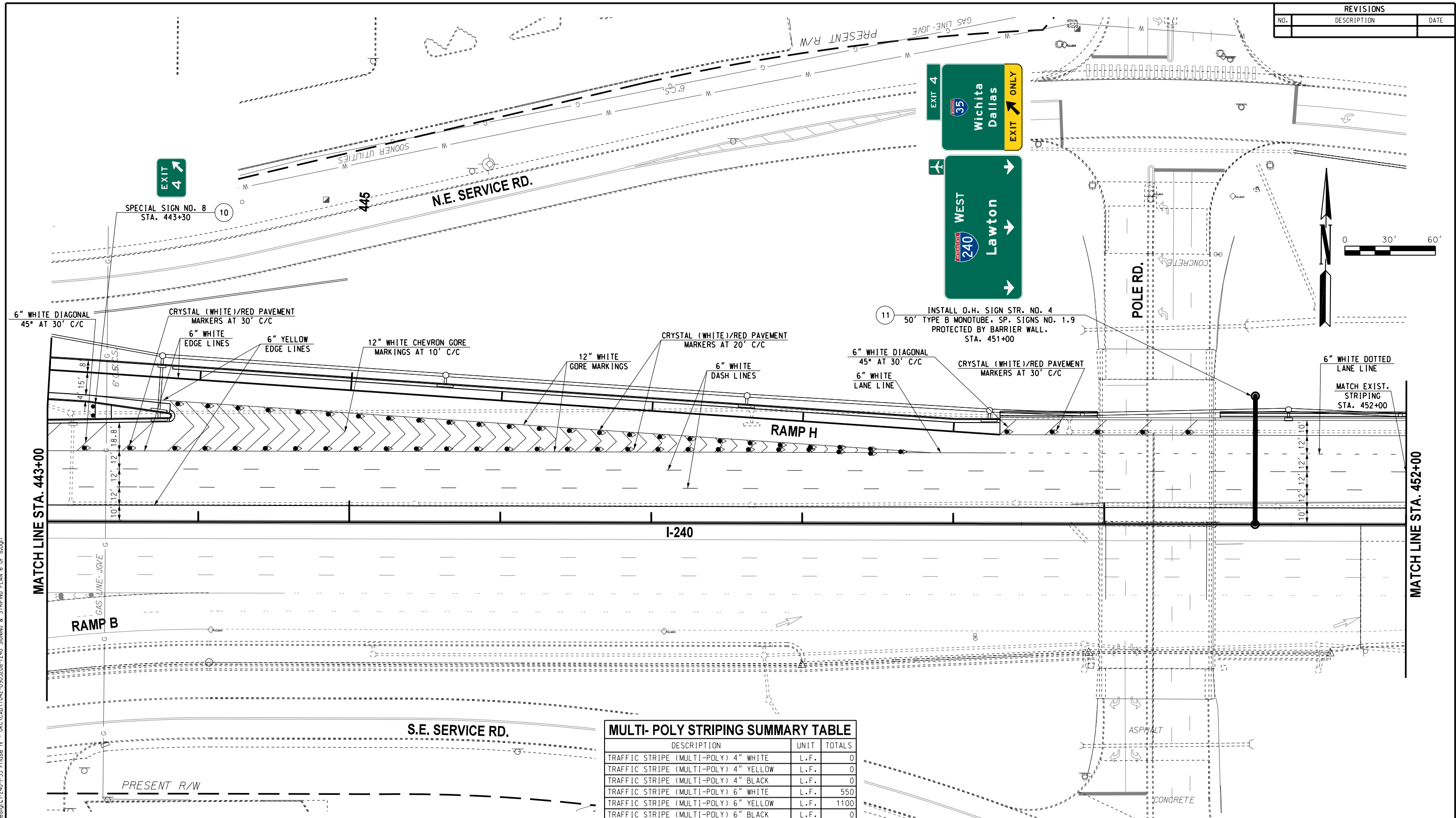

03-12-24 G:\V\Projects\I-240\1-35 Phase IV - OK\CAD\T042-0903208-1240 SIGNING & STRIPING PLAN 6 OF 8.dgn



FOR MORE INFORMATION ON RAISED PAVEMENT MARKERS AND DELINEATORS, SEE TYPICAL DETAIL SHEETS.

DESCRIPTION	UNIT	TOTALS
◊ COLOR A - CRYSTAL/CRYSTAL (WHITE/WHITE)	EA.	0
◊ COLOR C - CRYSTAL/RED (WHITE/RED)	EA.	56
◊ COLOR D - AMBER/AMBER (YELLOW/YELLOW)	EA.	0
◊ COLOR E - AMBER/RED (YELLOW/RED)	EA.	0
▬ TYPE 1 - FLEXIBLE DRIVEABLE DELINEATOR	EA.	0

DESCRIPTION	UNIT	TOTALS
TRAFFIC STRIPE (MULTI-POLY) 4" WHITE	L.F.	0
TRAFFIC STRIPE (MULTI-POLY) 4" YELLOW	L.F.	0
TRAFFIC STRIPE (MULTI-POLY) 4" BLACK	L.F.	0
TRAFFIC STRIPE (MULTI-POLY) 6" WHITE	L.F.	550
TRAFFIC STRIPE (MULTI-POLY) 6" YELLOW	L.F.	1100
TRAFFIC STRIPE (MULTI-POLY) 6" BLACK	L.F.	0
TRAFFIC STRIPE (MULTI-POLY) 8" WHITE	L.F.	0
TRAFFIC STRIPE (MULTI-POLY) 8" YELLOW	L.F.	0
TRAFFIC STRIPE (MULTI-POLY) 8" BLACK	L.F.	0
TRAFFIC STRIPE (MULTI-POLY) 12" WHITE	L.F.	3000
TRAFFIC STRIPE (MULTI-POLY) 12" YELLOW	L.F.	0
TRAFFIC STRIPE (MULTI-POLY) 12" BLACK	L.F.	0
TRAFFIC STRIPE (MULTI-POLY) 24" WHITE	L.F.	0
TRAFFIC STRIPE (MULTI-POLY) ARROWS	EA.	0
TRAFFIC STRIPE (MULTI-POLY) WORDS	EA.	0
TRAFFIC STRIPE (MULTI-POLY) SYMBOLS	EA.	0

CONTRACTOR TO REMOVE ALL CONFLICTING STRIPING.

Design	MSH	03-12-24
Drawn	SB	03-12-24



REVISIONS		
NO.	DESCRIPTION	DATE

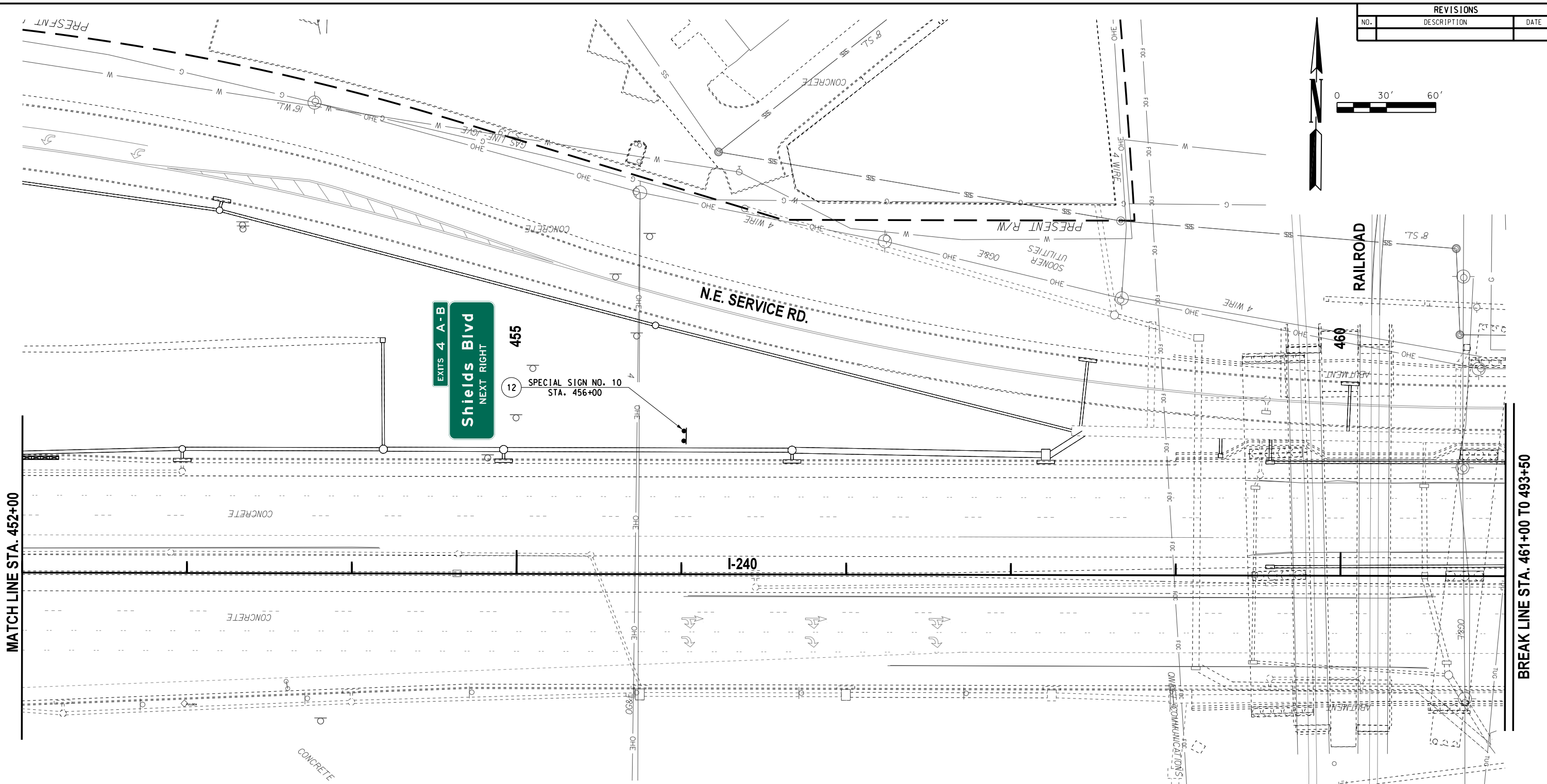
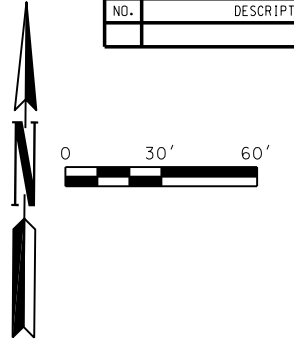

MULTI-POLY STRIPING SUMMARY TABLE

DESCRIPTION	UNIT	TOTALS
TRAFFIC STRIPE (MULTI-POLY) 4" WHITE	L.F.	0
TRAFFIC STRIPE (MULTI-POLY) 4" YELLOW	L.F.	0
TRAFFIC STRIPE (MULTI-POLY) 4" BLACK	L.F.	0
TRAFFIC STRIPE (MULTI-POLY) 6" WHITE	L.F.	0
TRAFFIC STRIPE (MULTI-POLY) 6" YELLOW	L.F.	0
TRAFFIC STRIPE (MULTI-POLY) 6" BLACK	L.F.	0
TRAFFIC STRIPE (MULTI-POLY) 8" WHITE	L.F.	0
TRAFFIC STRIPE (MULTI-POLY) 8" YELLOW	L.F.	0
TRAFFIC STRIPE (MULTI-POLY) 8" BLACK	L.F.	0
TRAFFIC STRIPE (MULTI-POLY) 12" WHITE	L.F.	0
TRAFFIC STRIPE (MULTI-POLY) 12" YELLOW	L.F.	0
TRAFFIC STRIPE (MULTI-POLY) 12" BLACK	L.F.	0
TRAFFIC STRIPE (MULTI-POLY) 24" WHITE	L.F.	0
TRAFFIC STRIPE (MULTI-POLY) ARROWS	EA.	0
TRAFFIC STRIPE (MULTI-POLY) WORDS	EA.	0
TRAFFIC STRIPE (MULTI-POLY) SYMBOLS	EA.	0

CLASS A, TYPE 2 PAVEMENT MARKER / DELINEATOR SUMMARY TABLE

DESCRIPTION	UNIT	TOTALS
◊ COLOR A - CRYSTAL/CRYSTAL (WHITE/WHITE)	EA.	0
◊ COLOR C - CRYSTAL/RED (WHITE/RED)	EA.	0
◊ COLOR D - AMBER/AMBER (YELLOW/YELLOW)	EA.	0
◊ COLOR E - AMBER/RED (YELLOW/RED)	EA.	0
— TYPE 1 - FLEXIBLE DRIVEABLE DELINEATOR	EA.	0

FOR MORE INFORMATION ON RAISED PAVEMENT MARKERS AND DELINEATORS, SEE TYPICAL DETAIL SHEETS.



CONTRACTOR TO REMOVE ALL CONFLICTING STRIPING.

Design	MSH	03-12-24
Drawn	SB	03-12-24



**I-240 SIGNING & STRIPING
7 OF 8**

03-12-24 G:\0\Projects\T-245\TE Design_I-240-I-35 Phase IV - OKLA CAD\T043-0903208-I-240 SIGNING & STRIPING PLAN 7 OF 8.dgn

REVISIONS		
NO.	DESCRIPTION	DATE

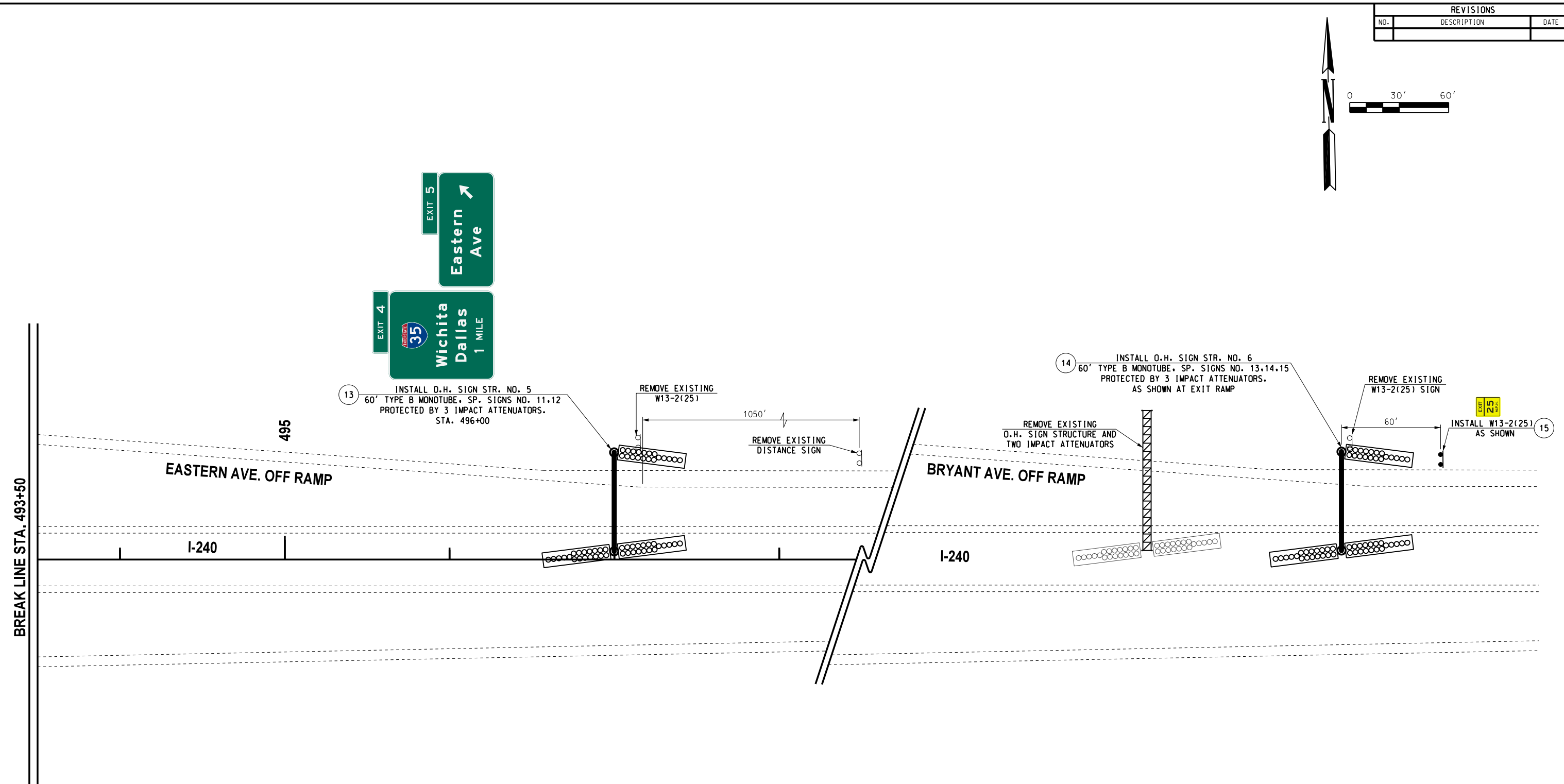
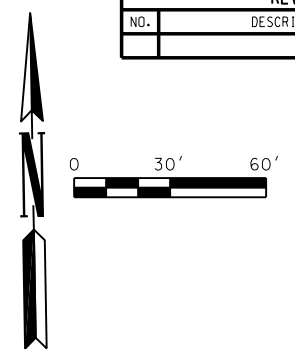

MULTI- POLY STRIPING SUMMARY TABLE

DESCRIPTION	UNIT	TOTALS
TRAFFIC STRIPE (MULTI-POLY) 4" WHITE	L.F.	0
TRAFFIC STRIPE (MULTI-POLY) 4" YELLOW	L.F.	0
TRAFFIC STRIPE (MULTI-POLY) 4" BLACK	L.F.	0
TRAFFIC STRIPE (MULTI-POLY) 6" WHITE	L.F.	0
TRAFFIC STRIPE (MULTI-POLY) 6" YELLOW	L.F.	0
TRAFFIC STRIPE (MULTI-POLY) 6" BLACK	L.F.	0
TRAFFIC STRIPE (MULTI-POLY) 8" WHITE	L.F.	0
TRAFFIC STRIPE (MULTI-POLY) 8" YELLOW	L.F.	0
TRAFFIC STRIPE (MULTI-POLY) 8" BLACK	L.F.	0
TRAFFIC STRIPE (MULTI-POLY) 12" WHITE	L.F.	0
TRAFFIC STRIPE (MULTI-POLY) 12" YELLOW	L.F.	0
TRAFFIC STRIPE (MULTI-POLY) 12" BLACK	L.F.	0
TRAFFIC STRIPE (MULTI-POLY) 24" WHITE	L.F.	0
TRAFFIC STRIPE (MULTI-POLY) ARROWS	EA.	0
TRAFFIC STRIPE (MULTI-POLY) WORDS	EA.	0
TRAFFIC STRIPE (MULTI-POLY) SYMBOLS	EA.	0

**CLASS A, TYPE 2 PAVEMENT MARKER /
DELINEATOR SUMMARY TABLE**

DESCRIPTION	UNIT	TOTALS
◊ COLOR A - CRYSTAL/CRYSTAL (WHITE/WHITE)	EA.	0
◊ COLOR C - CRYSTAL/RED (WHITE/RED)	EA.	0
◊ COLOR D - AMBER/AMBER (YELLOW/YELLOW)	EA.	0
◊ COLOR E - AMBER/RED (YELLOW/RED)	EA.	0
— TYPE 1 - FLEXIBLE DRIVEABLE DELINEATOR	EA.	0

**FOR MORE INFORMATION ON
RAISED PAVEMENT MARKERS
AND DELINEATORS, SEE
TYPICAL DETAIL SHEETS.**

**CONTRACTOR TO REMOVE
ALL CONFLICTING STRIPING.**

Design	MSH	03-12-24
Drawn	SB	03-12-24



**I-240 SIGNING & STRIPING
8 OF 8**

State Job No. 09032(08) Sheet No. T044

03-12-24 G:\0\Projects\T-245\T-245\Design_I-240-I-35 Phase IV - OKLA CAD\T044-0903208-I-240 SIGNING & STRIPING PLAN 8 OF 8.dgn



REVISIONS		
NO.	DESCRIPTION	DATE

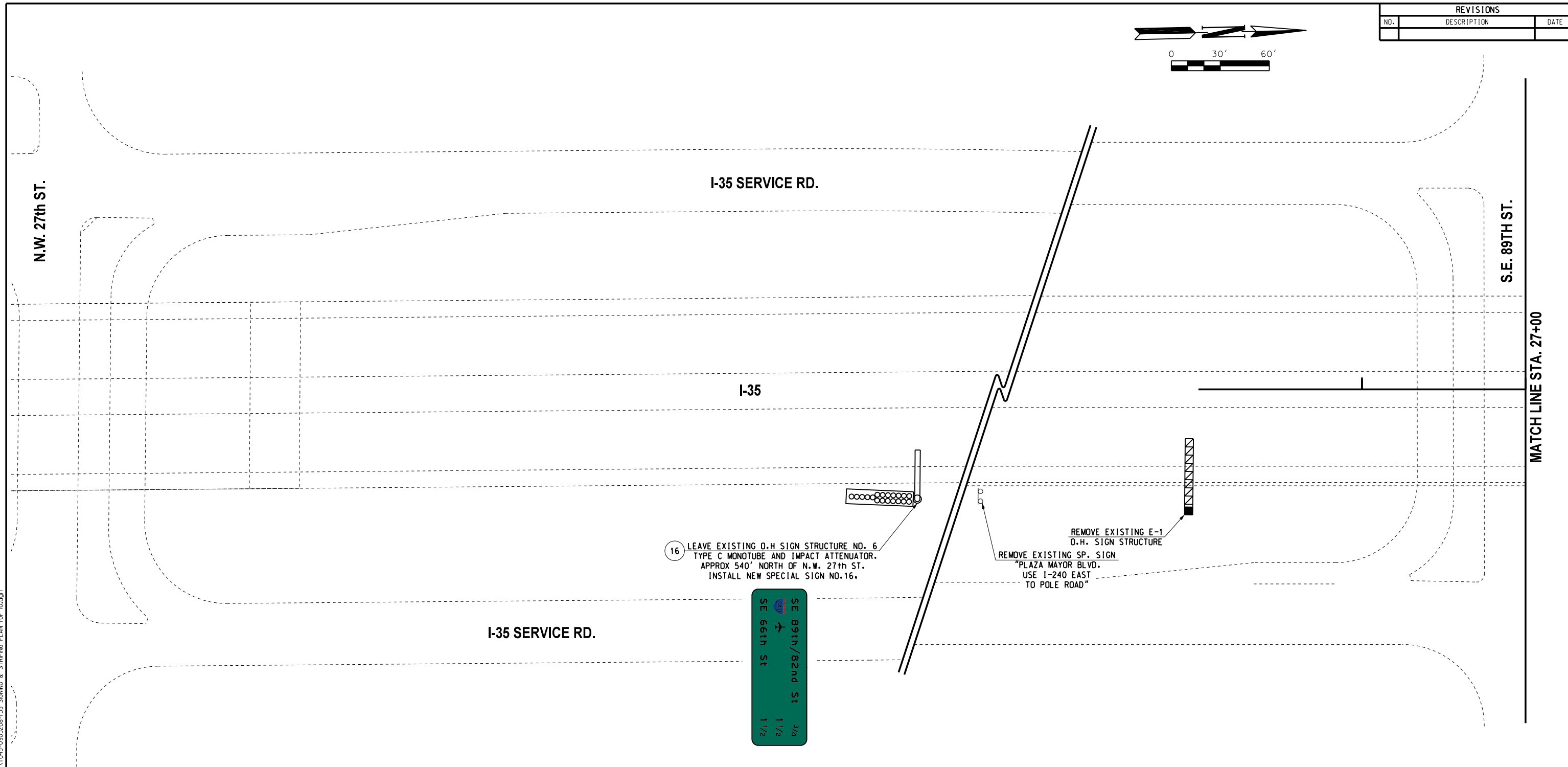
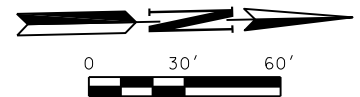

MULTI- POLY STRIPING SUMMARY TABLE

DESCRIPTION	UNIT	TOTALS
TRAFFIC STRIPE (MULTI-POLY) 4" WHITE	L.F.	0
TRAFFIC STRIPE (MULTI-POLY) 4" YELLOW	L.F.	0
TRAFFIC STRIPE (MULTI-POLY) 4" BLACK	L.F.	0
TRAFFIC STRIPE (MULTI-POLY) 6" WHITE	L.F.	0
TRAFFIC STRIPE (MULTI-POLY) 6" YELLOW	L.F.	0
TRAFFIC STRIPE (MULTI-POLY) 6" BLACK	L.F.	0
TRAFFIC STRIPE (MULTI-POLY) 8" WHITE	L.F.	0
TRAFFIC STRIPE (MULTI-POLY) 8" YELLOW	L.F.	0
TRAFFIC STRIPE (MULTI-POLY) 8" BLACK	L.F.	0
TRAFFIC STRIPE (MULTI-POLY) 12" WHITE	L.F.	0
TRAFFIC STRIPE (MULTI-POLY) 12" YELLOW	L.F.	0
TRAFFIC STRIPE (MULTI-POLY) 12" BLACK	L.F.	0
TRAFFIC STRIPE (MULTI-POLY) 24" WHITE	L.F.	0
TRAFFIC STRIPE (MULTI-POLY) ARROWS	EA.	0
TRAFFIC STRIPE (MULTI-POLY) WORDS	EA.	0
TRAFFIC STRIPE (MULTI-POLY) SYMBOLS	EA.	0

CLASS A, TYPE 2 PAVEMENT MARKER / DELINEATOR SUMMARY TABLE

DESCRIPTION	UNIT	TOTALS
◊ COLOR A - CRYSTAL/CRYSTAL (WHITE/WHITE)	EA.	0
◊ COLOR C - CRYSTAL/RED (WHITE/RED)	EA.	0
◊ COLOR D - AMBER/AMBER (YELLOW/YELLOW)	EA.	0
◊ COLOR E - AMBER/RED (YELLOW/RED)	EA.	0
— TYPE 1 - FLEXIBLE DRIVEABLE DELINEATOR	EA.	0

FOR MORE INFORMATION ON RAISED PAVEMENT MARKERS AND DELINEATORS, SEE TYPICAL DETAIL SHEETS.

CONTRACTOR TO REMOVE ALL CONFLICTING STRIPING.

Design	MSH	03-12-24
Drawn	SB	03-12-24



I-35 SIGNING & STRIPING
1 OF 10

State Job No. 09032(08) Sheet No. I045

03-12-24 G:\VOP\Projects\I-240-I-35 Phase IV - OKLA CAD\T045-0903208-I35_SIGNING & STRIPING PLAN I045.dgn



03-12-24 G:\V\Projects\1-2457E_Design\1-240-1-35_Phase IV - OKLA CAD\1046-0903208-135_SIGNING & STRIPING PLAN 2 OF 10.dgn



FOR MORE INFORMATION ON RAISED PAVEMENT MARKERS AND DELINEATORS, SEE TYPICAL DETAIL SHEETS.

CLASS A, TYPE 2 PAVEMENT MARKER / DELINEATOR SUMMARY TABLE		
DESCRIPTION	UNIT	TOTALS
◊ COLOR A - CRYSTAL/CRYSTAL (WHITE/WHITE)	EA.	0
◊ COLOR C - CRYSTAL/RED (WHITE/RED)	EA.	0
◊ COLOR D - AMBER/AMBER (YELLOW/YELLOW)	EA.	0
◊ COLOR E - AMBER/RED (YELLOW/RED)	EA.	0
— TYPE 1 - FLEXIBLE DRIVEABLE DELINEATOR	EA.	0

MULTI-POLY STRIPING SUMMARY TABLE		
DESCRIPTION	UNIT	TOTALS
TRAFFIC STRIPE (MULTI-POLY) 4" WHITE	L.F.	0
TRAFFIC STRIPE (MULTI-POLY) 4" YELLOW	L.F.	0
TRAFFIC STRIPE (MULTI-POLY) 4" BLACK	L.F.	0
TRAFFIC STRIPE (MULTI-POLY) 6" WHITE	L.F.	0
TRAFFIC STRIPE (MULTI-POLY) 6" YELLOW	L.F.	0
TRAFFIC STRIPE (MULTI-POLY) 6" BLACK	L.F.	0
TRAFFIC STRIPE (MULTI-POLY) 8" WHITE	L.F.	0
TRAFFIC STRIPE (MULTI-POLY) 8" YELLOW	L.F.	0
TRAFFIC STRIPE (MULTI-POLY) 8" BLACK	L.F.	0
TRAFFIC STRIPE (MULTI-POLY) 12" WHITE	L.F.	0
TRAFFIC STRIPE (MULTI-POLY) 12" YELLOW	L.F.	0
TRAFFIC STRIPE (MULTI-POLY) 12" BLACK	L.F.	0
TRAFFIC STRIPE (MULTI-POLY) 24" WHITE	L.F.	0
TRAFFIC STRIPE (MULTI-POLY) ARROWS	EA.	0
TRAFFIC STRIPE (MULTI-POLY) WORDS	EA.	0
TRAFFIC STRIPE (MULTI-POLY) SYMBOLS	EA.	0

CONTRACTOR TO REMOVE ALL CONFLICTING STRIPING.

Design	MSH	03-12-24
Drawn	SB	03-12-24

I-35 SIGNING & STRIPING
2 OF 10
State Job No. 09032(08) Sheet No. 1046
OKLAHOMA COUNTY

REVISIONS		
NO.	DESCRIPTION	DATE

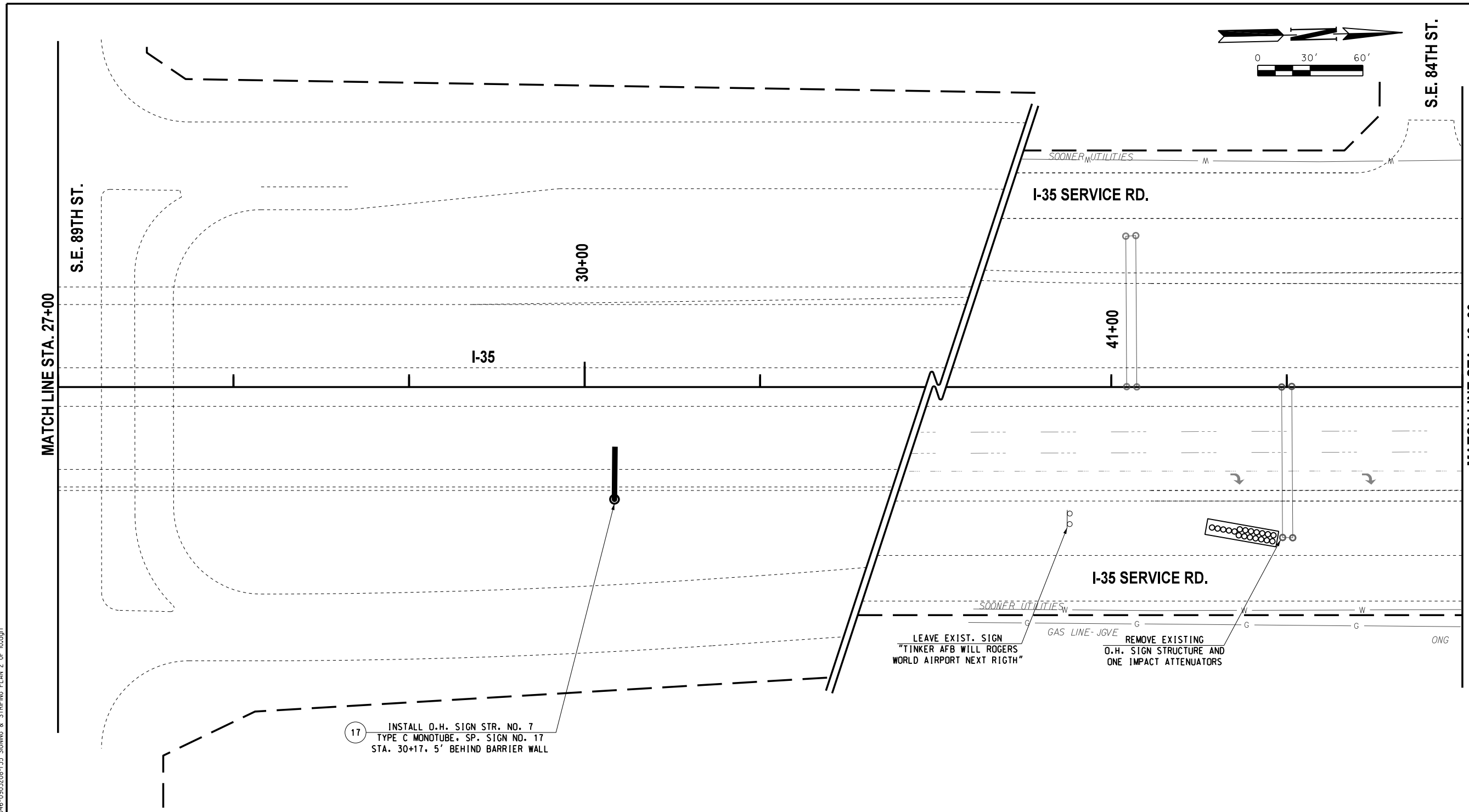

17 INSTALL O.H. SIGN STR. NO. 7
TYPE C MONOTUBE, SP. SIGN NO. 17
STA. 30+17, 5' BEHIND BARRIER WALL

LEAVE EXIST. SIGN
"TINKER AFB WILL ROGERS
WORLD AIRPORT NEXT RIGTH"
REMOVE EXISTING
O.H. SIGN STRUCTURE AND
ONE IMPACT ATTENUATORS

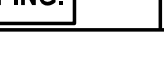
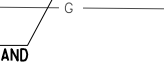
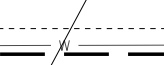
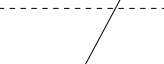
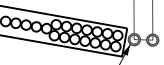

REVISIONS		
NO.	DESCRIPTION	DATE

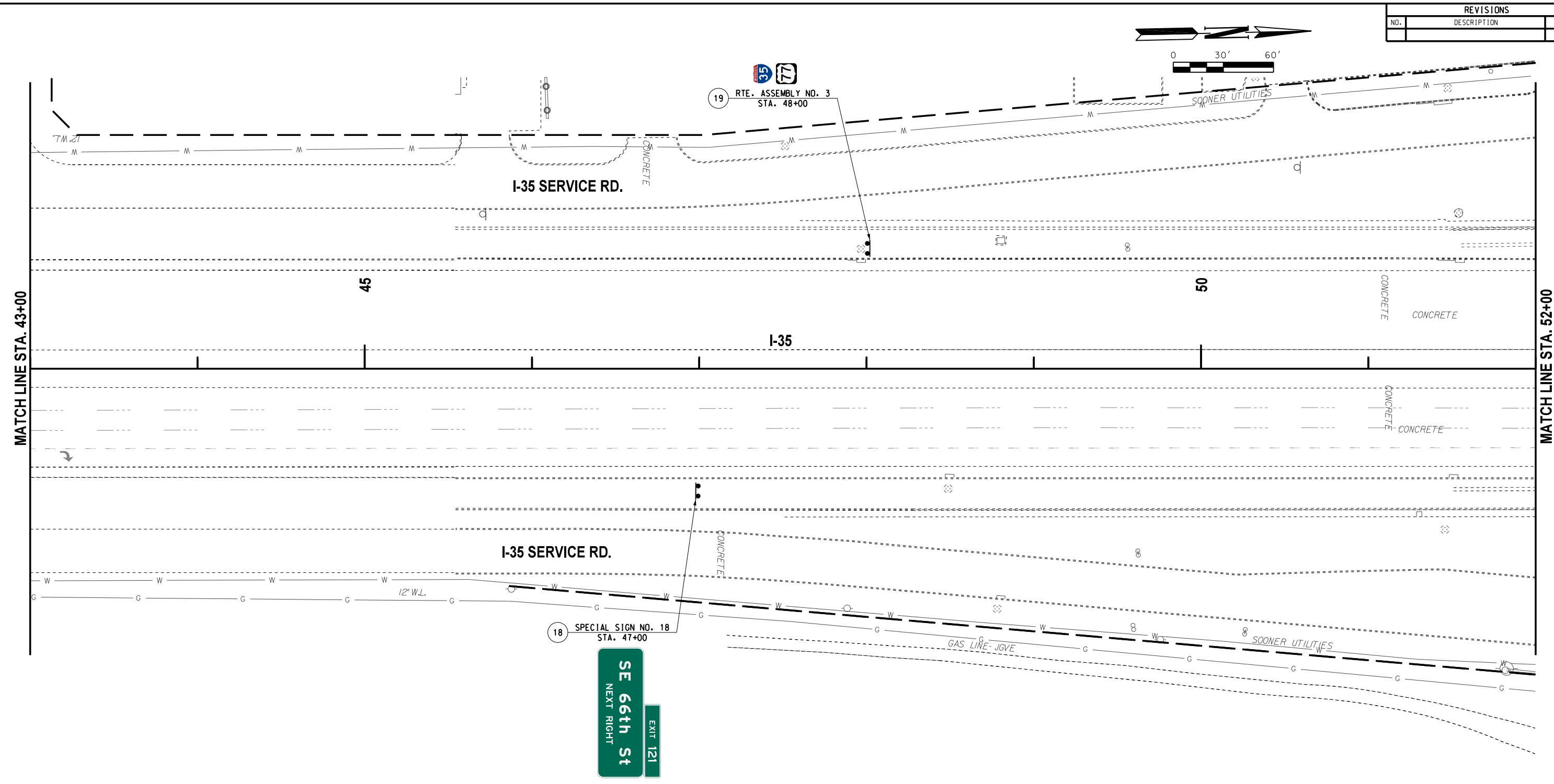
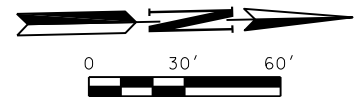

18 SPECIAL SIGN NO. 18
STA. 47+00

SE 66th St
NEXT RIGHT
EXIT 121

MULTI- POLY STRIPING SUMMARY TABLE

DESCRIPTION	UNIT	TOTALS
TRAFFIC STRIPE (MULTI-POLY) 4" WHITE	L.F.	0
TRAFFIC STRIPE (MULTI-POLY) 4" YELLOW	L.F.	0
TRAFFIC STRIPE (MULTI-POLY) 4" BLACK	L.F.	0
TRAFFIC STRIPE (MULTI-POLY) 6" WHITE	L.F.	0
TRAFFIC STRIPE (MULTI-POLY) 6" YELLOW	L.F.	0
TRAFFIC STRIPE (MULTI-POLY) 6" BLACK	L.F.	0
TRAFFIC STRIPE (MULTI-POLY) 8" WHITE	L.F.	0
TRAFFIC STRIPE (MULTI-POLY) 8" YELLOW	L.F.	0
TRAFFIC STRIPE (MULTI-POLY) 8" BLACK	L.F.	0
TRAFFIC STRIPE (MULTI-POLY) 12" WHITE	L.F.	0
TRAFFIC STRIPE (MULTI-POLY) 12" YELLOW	L.F.	0
TRAFFIC STRIPE (MULTI-POLY) 12" BLACK	L.F.	0
TRAFFIC STRIPE (MULTI-POLY) 24" WHITE	L.F.	0
TRAFFIC STRIPE (MULTI-POLY) ARROWS	EA.	0
TRAFFIC STRIPE (MULTI-POLY) WORDS	EA.	0
TRAFFIC STRIPE (MULTI-POLY) SYMBOLS	EA.	0

CLASS A, TYPE 2 PAVEMENT MARKER / DELINEATOR SUMMARY TABLE

DESCRIPTION	UNIT	TOTALS
◊ COLOR A - CRYSTAL/CRYSTAL (WHITE/WHITE)	EA.	0
◊ COLOR C - CRYSTAL/RED (WHITE/RED)	EA.	0
◊ COLOR D - AMBER/AMBER (YELLOW/YELLOW)	EA.	0
◊ COLOR E - AMBER/RED (YELLOW/RED)	EA.	0
— TYPE 1 - FLEXIBLE DRIVEABLE DELINEATOR	EA.	0

FOR MORE INFORMATION ON RAISED PAVEMENT MARKERS AND DELINEATORS, SEE TYPICAL DETAIL SHEETS.

CONTRACTOR TO REMOVE ALL CONFLICTING STRIPING.

Design MSH 03-12-24
Drawn SB 03-12-24



I-35 SIGNING & STRIPING
3 OF 9

State Job No. 09032(08) Sheet No. T047

03-12-24 G:\V\Projects\T-245\TE Design_I-240-I-35 Phase IV - OK\CAD\T047-0903208-I-35_SIGNING & STRIPING PLAN 3 OF 10.dgn



REVISIONS		
NO.	DESCRIPTION	DATE

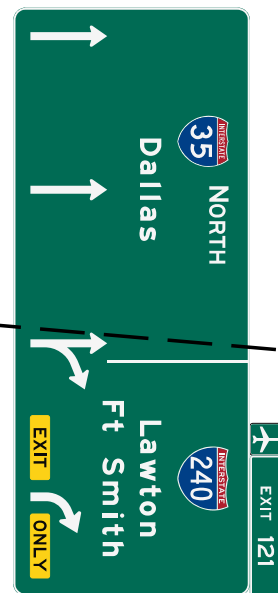
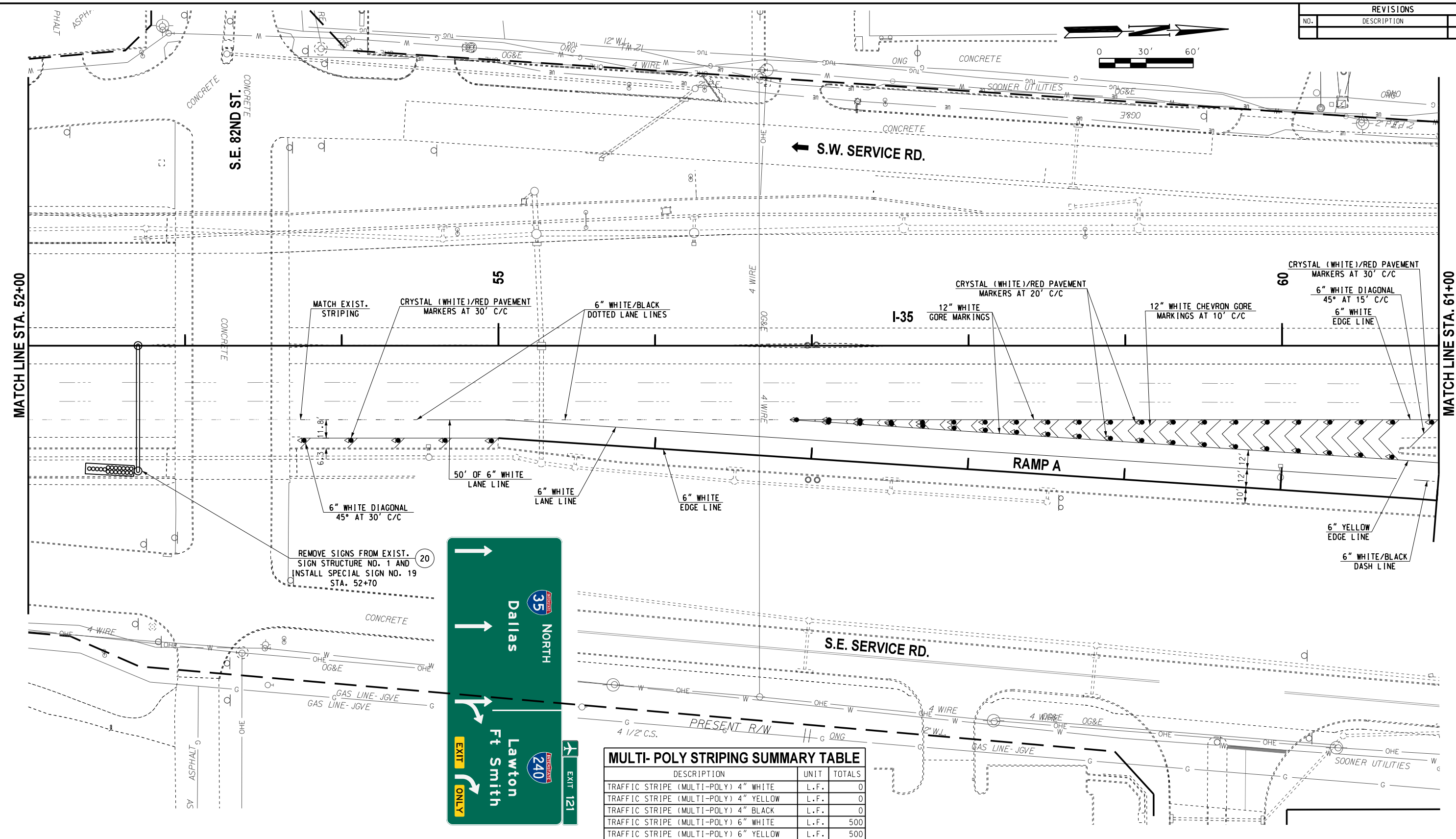
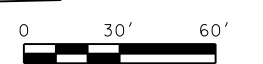

MULTI-POLY STRIPING SUMMARY TABLE

DESCRIPTION	UNIT	TOTALS
TRAFFIC STRIPE (MULTI-POLY) 4" WHITE	L.F.	0
TRAFFIC STRIPE (MULTI-POLY) 4" YELLOW	L.F.	0
TRAFFIC STRIPE (MULTI-POLY) 4" BLACK	L.F.	0
TRAFFIC STRIPE (MULTI-POLY) 6" WHITE	L.F.	500
TRAFFIC STRIPE (MULTI-POLY) 6" YELLOW	L.F.	500
TRAFFIC STRIPE (MULTI-POLY) 6" BLACK	L.F.	0
TRAFFIC STRIPE (MULTI-POLY) 8" WHITE	L.F.	0
TRAFFIC STRIPE (MULTI-POLY) 8" YELLOW	L.F.	0
TRAFFIC STRIPE (MULTI-POLY) 8" BLACK	L.F.	0
TRAFFIC STRIPE (MULTI-POLY) 12" WHITE	L.F.	1000
TRAFFIC STRIPE (MULTI-POLY) 12" YELLOW	L.F.	0
TRAFFIC STRIPE (MULTI-POLY) 12" BLACK	L.F.	0
TRAFFIC STRIPE (MULTI-POLY) 24" WHITE	L.F.	0
TRAFFIC STRIPE (MULTI-POLY) ARROWS	EA.	0
TRAFFIC STRIPE (MULTI-POLY) WORDS	EA.	0
TRAFFIC STRIPE (MULTI-POLY) SYMBOLS	EA.	0

CLASS A, TYPE 2 PAVEMENT MARKER / DELINEATOR SUMMARY TABLE

DESCRIPTION	UNIT	TOTALS
◊ COLOR A - CRYSTAL/CRYSTAL (WHITE/WHITE)	EA.	0
◊ COLOR C - CRYSTAL/RED (WHITE/RED)	EA.	41
◊ COLOR D - AMBER/AMBER (YELLOW/YELLOW)	EA.	0
◊ COLOR E - AMBER/RED (YELLOW/RED)	EA.	0
┌ TYPE 1 - FLEXIBLE DRIVEABLE DELINEATOR	EA.	0

FOR MORE INFORMATION ON RAISED PAVEMENT MARKERS AND DELINEATORS, SEE TYPICAL DETAIL SHEETS.

CONTRACTOR TO REMOVE ALL CONFLICTING STRIPING.

Design MSH 03-12-24
Drawn SB 03-12-24



I-35 SIGNING & STRIPING
4 OF 10

03-12-24 G:\V\Projects\T-2457E Design-I-35 Phase IV - OKLA CAD\T048-0903208-135_SIGNING & STRIPING PLAN 4 OF 10.dgn



REVISIONS		
NO.	DESCRIPTION	DATE

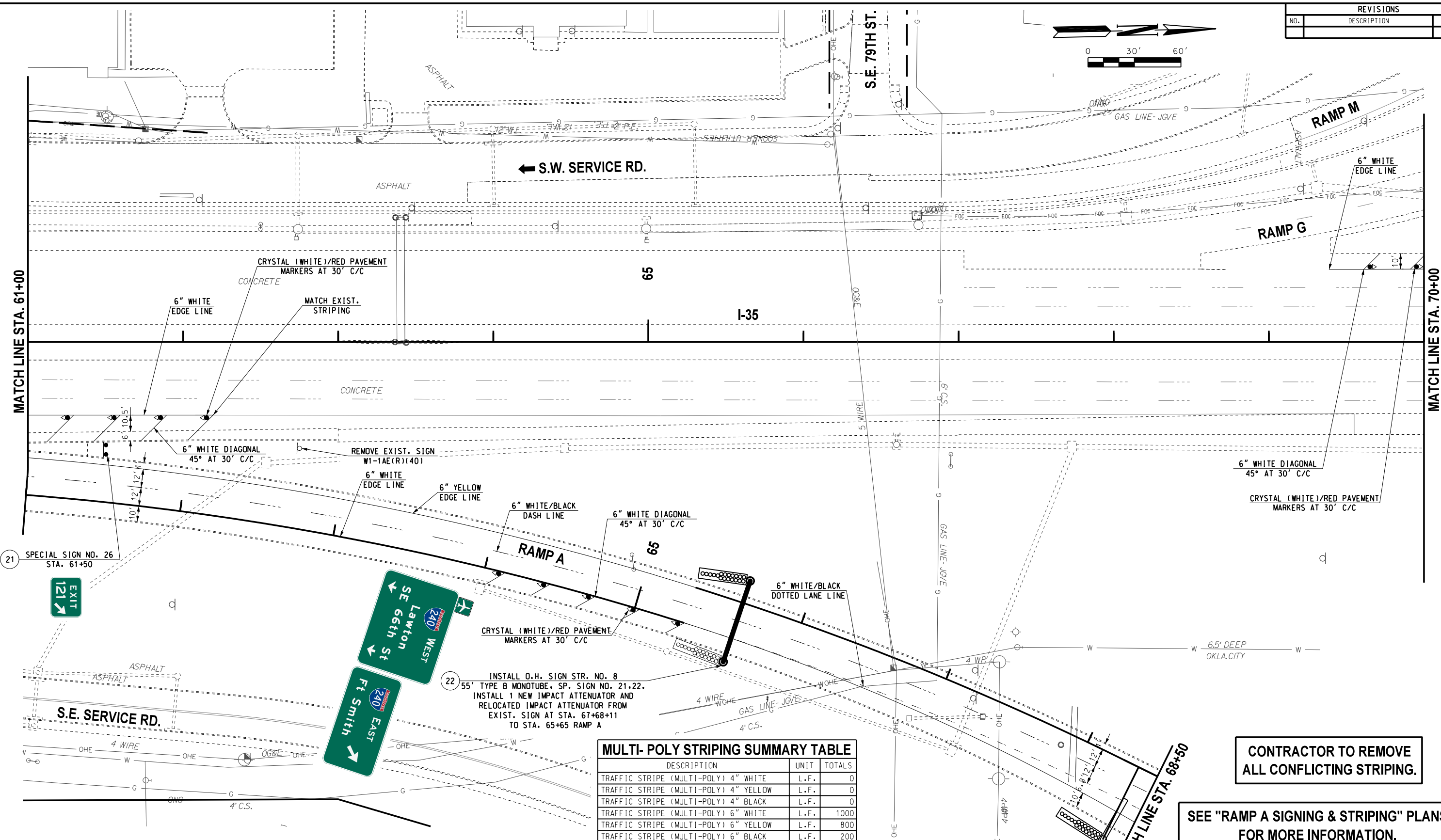
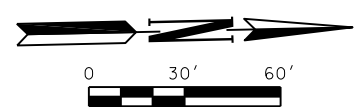

MATCH LINE STA. 61+00

MATCH LINE STA. 70+00

21 SPECIAL SIGN NO. 26
STA. 61+50

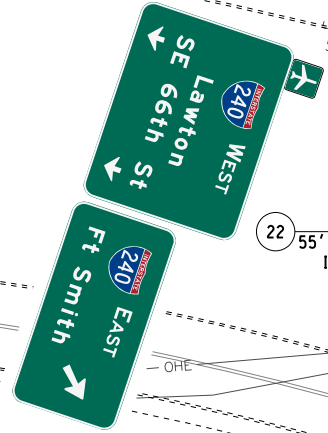

22 INSTALL O.H. SIGN STR. NO. 8
55' TYPE B MONOTUBE, SP. SIGN NO. 21.22.
INSTALL 1 NEW IMPACT ATTENUATOR AND
RELOCATED IMPACT ATTENUATOR FROM
EXIST. SIGN AT STA. 67+68+11
TO STA. 65+65 RAMP A

MULTI- POLY STRIPING SUMMARY TABLE

DESCRIPTION	UNIT	TOTALS
TRAFFIC STRIPE (MULTI-POLY) 4" WHITE	L.F.	0
TRAFFIC STRIPE (MULTI-POLY) 4" YELLOW	L.F.	0
TRAFFIC STRIPE (MULTI-POLY) 4" BLACK	L.F.	0
TRAFFIC STRIPE (MULTI-POLY) 6" WHITE	L.F.	1000
TRAFFIC STRIPE (MULTI-POLY) 6" YELLOW	L.F.	800
TRAFFIC STRIPE (MULTI-POLY) 6" BLACK	L.F.	200
TRAFFIC STRIPE (MULTI-POLY) 8" WHITE	L.F.	0
TRAFFIC STRIPE (MULTI-POLY) 8" YELLOW	L.F.	0
TRAFFIC STRIPE (MULTI-POLY) 8" BLACK	L.F.	0
TRAFFIC STRIPE (MULTI-POLY) 12" WHITE	L.F.	200
TRAFFIC STRIPE (MULTI-POLY) 12" YELLOW	L.F.	0
TRAFFIC STRIPE (MULTI-POLY) 12" BLACK	L.F.	0
TRAFFIC STRIPE (MULTI-POLY) 24" WHITE	L.F.	0
TRAFFIC STRIPE (MULTI-POLY) ARROWS	EA.	0
TRAFFIC STRIPE (MULTI-POLY) WORDS	EA.	0
TRAFFIC STRIPE (MULTI-POLY) SYMBOLS	EA.	0

CLASS A, TYPE 2 PAVEMENT MARKER / DELINEATOR SUMMARY TABLE

DESCRIPTION	UNIT	TOTALS
◊ COLOR A - CRYSTAL/CRYSTAL (WHITE/WHITE)	EA.	0
◊ COLOR C - CRYSTAL/RED (WHITE/RED)	EA.	11
◊ COLOR D - AMBER/AMBER (YELLOW/YELLOW)	EA.	0
◊ COLOR E - AMBER/RED (YELLOW/RED)	EA.	0
┌ TYPE 1 - FLEXIBLE DRIVEABLE DELINEATOR	EA.	0

CONTRACTOR TO REMOVE ALL CONFLICTING STRIPING.

SEE "RAMP A SIGNING & STRIPING" PLANS FOR MORE INFORMATION.

REMOVE EXISTING TYPE C MONOTUBE O.H. SIGN STRUCTURE AND RELOCATE ONE IMPACT ATTENUATOR TO NEW O.H. SIGN STRUCTURE NO. 8 UPSTREAM AT STA. 65+65 RAMP A



FOR MORE INFORMATION ON RAISED PAVEMENT MARKERS AND DELINEATORS, SEE TYPICAL DETAIL SHEETS.

Design MSH 03-12-24
Drawn SB 03-12-24



I-35 SIGNING & STRIPING
5 OF 10

03-12-24 G:\V\Projects\1-2457E Design IV - OKLA CAD\T049-0903208-135_SIGNING & STRIPING PLAN 5 OF 10.dgn

REVISIONS		
NO.	DESCRIPTION	DATE

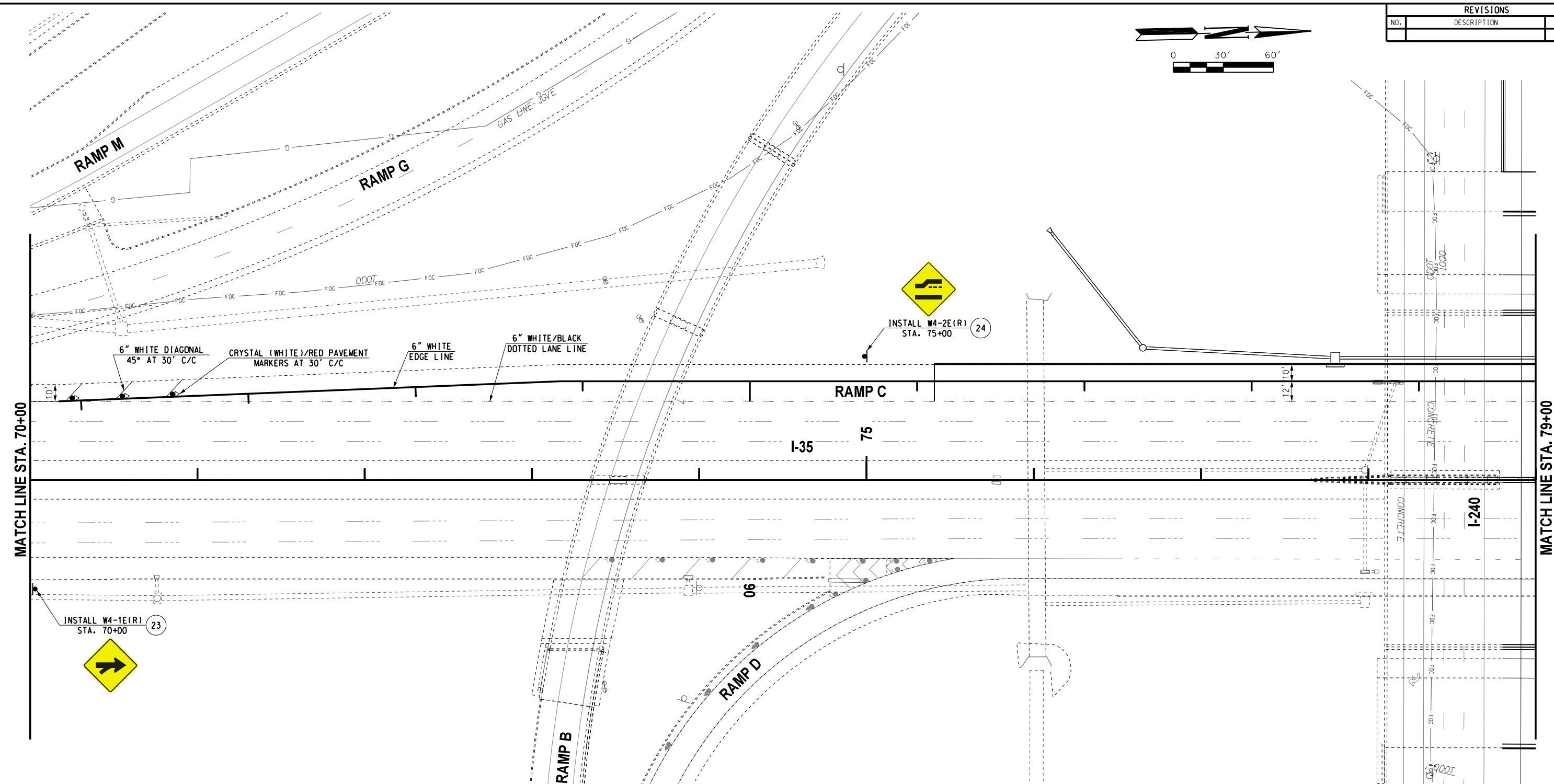
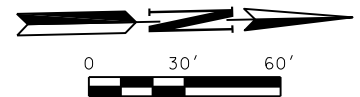

MATCH LINE STA. 70+00

MATCH LINE STA. 79+00

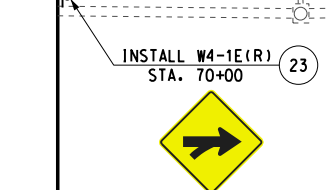

MULTI-POLY STRIPING SUMMARY TABLE			
DESCRIPTION	UNIT	TOTALS	
TRAFFIC STRIPE (MULTI-POLY) 4" WHITE	L.F.	0	
TRAFFIC STRIPE (MULTI-POLY) 4" YELLOW	L.F.	0	
TRAFFIC STRIPE (MULTI-POLY) 4" BLACK	L.F.	0	
TRAFFIC STRIPE (MULTI-POLY) 6" WHITE	L.F.	1110	
TRAFFIC STRIPE (MULTI-POLY) 6" YELLOW	L.F.	0	
TRAFFIC STRIPE (MULTI-POLY) 6" BLACK	L.F.	300	
TRAFFIC STRIPE (MULTI-POLY) 8" WHITE	L.F.	0	
TRAFFIC STRIPE (MULTI-POLY) 8" YELLOW	L.F.	0	
TRAFFIC STRIPE (MULTI-POLY) 8" BLACK	L.F.	0	
TRAFFIC STRIPE (MULTI-POLY) 12" WHITE	L.F.	0	
TRAFFIC STRIPE (MULTI-POLY) 12" YELLOW	L.F.	0	
TRAFFIC STRIPE (MULTI-POLY) 12" BLACK	L.F.	0	
TRAFFIC STRIPE (MULTI-POLY) 24" WHITE	L.F.	0	
TRAFFIC STRIPE (MULTI-POLY) ARROWS	EA.	0	
TRAFFIC STRIPE (MULTI-POLY) WORDS	EA.	0	
TRAFFIC STRIPE (MULTI-POLY) SYMBOLS	EA.	0	

CLASS A, TYPE 2 PAVEMENT MARKER / DELINEATOR SUMMARY TABLE			
DESCRIPTION	UNIT	TOTALS	
◊ COLOR A - CRYSTAL/CRYSTAL (WHITE/WHITE)	EA.	0	
◊ COLOR C - CRYSTAL/RED (WHITE/RED)	EA.	3	
◊ COLOR D - AMBER/AMBER (YELLOW/YELLOW)	EA.	0	
◊ COLOR E - AMBER/RED (YELLOW/RED)	EA.	0	
— TYPE 1 - FLEXIBLE DRIVEABLE DELINEATOR	EA.	0	

SEE "I-240 SIGNING & STRIPING" PLANS FOR MORE INFORMATION.

CONTRACTOR TO REMOVE ALL CONFLICTING STRIPING.

FOR MORE INFORMATION ON RAISED PAVEMENT MARKERS AND DELINEATORS, SEE TYPICAL DETAIL SHEETS.



Design	MSH	03-12-24
Drawn	SB	03-12-24



I-35 SIGNING & STRIPING
6 OF 10

03-12-24 G:\0\Projects\T-2457E Design, I-240-I-35 Phase IV - OKLAHOMA COUNTY DESIGN - SIGNING & STRIPING PLAN 6 OF 10.dgn

REVISIONS		
NO.	DESCRIPTION	DATE

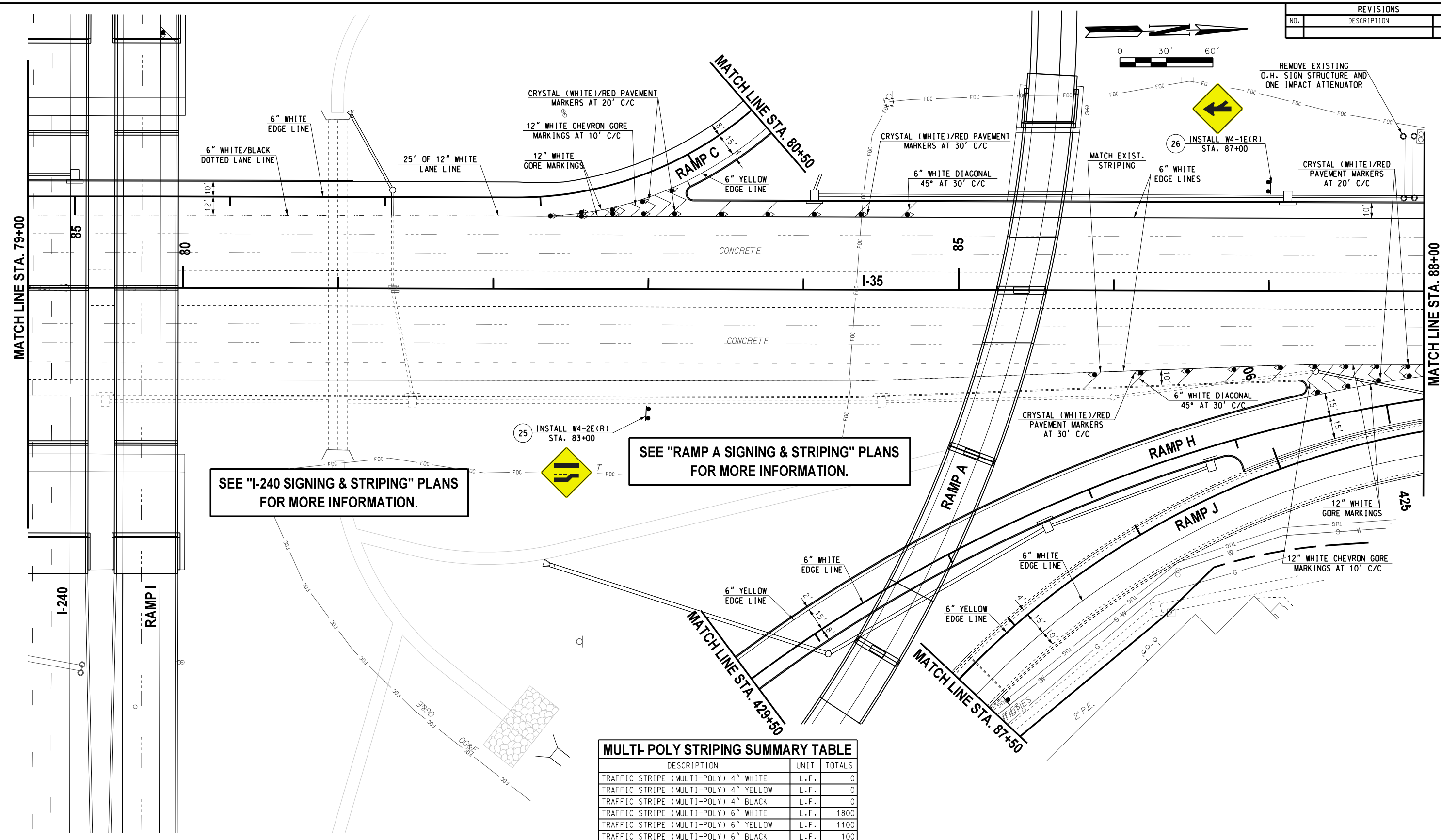
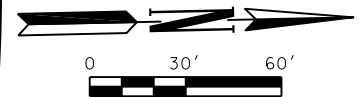

SEE "I-240 SIGNING & STRIPING" PLANS FOR MORE INFORMATION.

SEE "RAMP A SIGNING & STRIPING" PLANS FOR MORE INFORMATION.

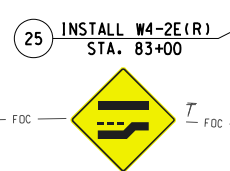

MULTI-POLY STRIPING SUMMARY TABLE

DESCRIPTION	UNIT	TOTALS
TRAFFIC STRIPE (MULTI-POLY) 4" WHITE	L.F.	0
TRAFFIC STRIPE (MULTI-POLY) 4" YELLOW	L.F.	0
TRAFFIC STRIPE (MULTI-POLY) 4" BLACK	L.F.	0
TRAFFIC STRIPE (MULTI-POLY) 6" WHITE	L.F.	1800
TRAFFIC STRIPE (MULTI-POLY) 6" YELLOW	L.F.	1100
TRAFFIC STRIPE (MULTI-POLY) 6" BLACK	L.F.	100
TRAFFIC STRIPE (MULTI-POLY) 8" WHITE	L.F.	0
TRAFFIC STRIPE (MULTI-POLY) 8" YELLOW	L.F.	0
TRAFFIC STRIPE (MULTI-POLY) 8" BLACK	L.F.	0
TRAFFIC STRIPE (MULTI-POLY) 12" WHITE	L.F.	250
TRAFFIC STRIPE (MULTI-POLY) 12" YELLOW	L.F.	0
TRAFFIC STRIPE (MULTI-POLY) 12" BLACK	L.F.	0
TRAFFIC STRIPE (MULTI-POLY) 24" WHITE	L.F.	0
TRAFFIC STRIPE (MULTI-POLY) ARROWS	EA.	0
TRAFFIC STRIPE (MULTI-POLY) WORDS	EA.	0
TRAFFIC STRIPE (MULTI-POLY) SYMBOLS	EA.	0

CLASS A, TYPE 2 PAVEMENT MARKER / DELINEATOR SUMMARY TABLE

DESCRIPTION	UNIT	TOTALS
◊ COLOR A - CRYSTAL/CRYSTAL (WHITE/WHITE)	EA.	0
◊ COLOR C - CRYSTAL/RED (WHITE/RED)	EA.	30
◊ COLOR D - AMBER/AMBER (YELLOW/YELLOW)	EA.	0
◊ COLOR E - AMBER/RED (YELLOW/RED)	EA.	0
— TYPE 1 - FLEXIBLE DRIVEABLE DELINEATOR	EA.	0

FOR MORE INFORMATION ON RAISED PAVEMENT MARKERS AND DELINEATORS, SEE TYPICAL DETAIL SHEETS.

CONTRACTOR TO REMOVE ALL CONFLICTING STRIPING.

Design MSH 03-12-24
Drawn SB 03-12-24



I-35 SIGNING & STRIPING
7 OF 10

03-12-24 G:\0\Projects\T-245\T-245\Design_I-240-I-35 Phase IV - OKLA CAD\T051-0903208-I-35 SIGNING & STRIPING PLAN 7 OF 10.dgn



REVISIONS		
NO.	DESCRIPTION	DATE

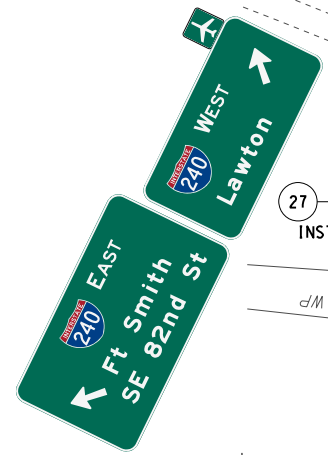
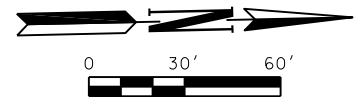

27 REMOVE SIGNS FROM EXIST. SIGN STRUCTURE NO. 2 AND INSTALL SPECIAL SIGNS NO. 23,24 STA. 406+33 RAMP B

28 SPECIAL SIGN NO. 20 STA. 401+75
6" WHITE DIAGONAL 45° AT 30' C/C

MULTI-POLY STRIPING SUMMARY TABLE		
DESCRIPTION	UNIT	TOTALS
TRAFFIC STRIPE (MULTI-POLY) 4" WHITE	L.F.	0
TRAFFIC STRIPE (MULTI-POLY) 4" YELLOW	L.F.	0
TRAFFIC STRIPE (MULTI-POLY) 4" BLACK	L.F.	0
TRAFFIC STRIPE (MULTI-POLY) 6" WHITE	L.F.	1000
TRAFFIC STRIPE (MULTI-POLY) 6" YELLOW	L.F.	1000
TRAFFIC STRIPE (MULTI-POLY) 6" BLACK	L.F.	500
TRAFFIC STRIPE (MULTI-POLY) 8" WHITE	L.F.	0
TRAFFIC STRIPE (MULTI-POLY) 8" YELLOW	L.F.	0
TRAFFIC STRIPE (MULTI-POLY) 8" BLACK	L.F.	0
TRAFFIC STRIPE (MULTI-POLY) 12" WHITE	L.F.	500
TRAFFIC STRIPE (MULTI-POLY) 12" YELLOW	L.F.	0
TRAFFIC STRIPE (MULTI-POLY) 12" BLACK	L.F.	0
TRAFFIC STRIPE (MULTI-POLY) 24" WHITE	L.F.	0
TRAFFIC STRIPE (MULTI-POLY) ARROWS	EA.	0
TRAFFIC STRIPE (MULTI-POLY) WORDS	EA.	0
TRAFFIC STRIPE (MULTI-POLY) SYMBOLS	EA.	0

CLASS A, TYPE 2 PAVEMENT MARKER / DELINEATOR SUMMARY TABLE		
DESCRIPTION	UNIT	TOTALS
◊ COLOR A - CRYSTAL/CRYSTAL (WHITE/WHITE)	EA.	0
◊ COLOR C - CRYSTAL/RED (WHITE/RED)	EA.	33
◊ COLOR D - AMBER/AMBER (YELLOW/YELLOW)	EA.	0
◊ COLOR E - AMBER/RED (YELLOW/RED)	EA.	0
— TYPE 1 - FLEXIBLE DRIVEABLE DELINEATOR	EA.	0

FOR MORE INFORMATION ON RAISED PAVEMENT MARKERS AND DELINEATORS, SEE TYPICAL DETAIL SHEETS.



CONTRACTOR TO REMOVE ALL CONFLICTING STRIPING.

Design MSH 03-12-24
Drawn SB 03-12-24



I-35 SIGNING & STRIPING
8 OF 10

03-12-24 G:\VOP\Projects\I-240-I-35 Phase IV - OKLA CAD\052-0903208-135_SIGNING & STRIPING PLAN 8 OF 10.dgn

REVISIONS		
NO.	DESCRIPTION	DATE

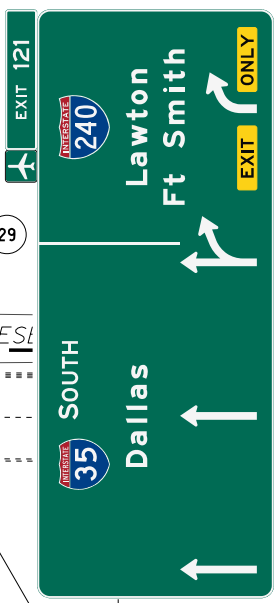
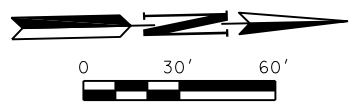

REMOVE SIGNS FROM EXIST. SIGN STRUCTURE NO. 3 AND INSTALL SPECIAL SIGN NO. 24 STA. 395+08 SOONER UTILITIES

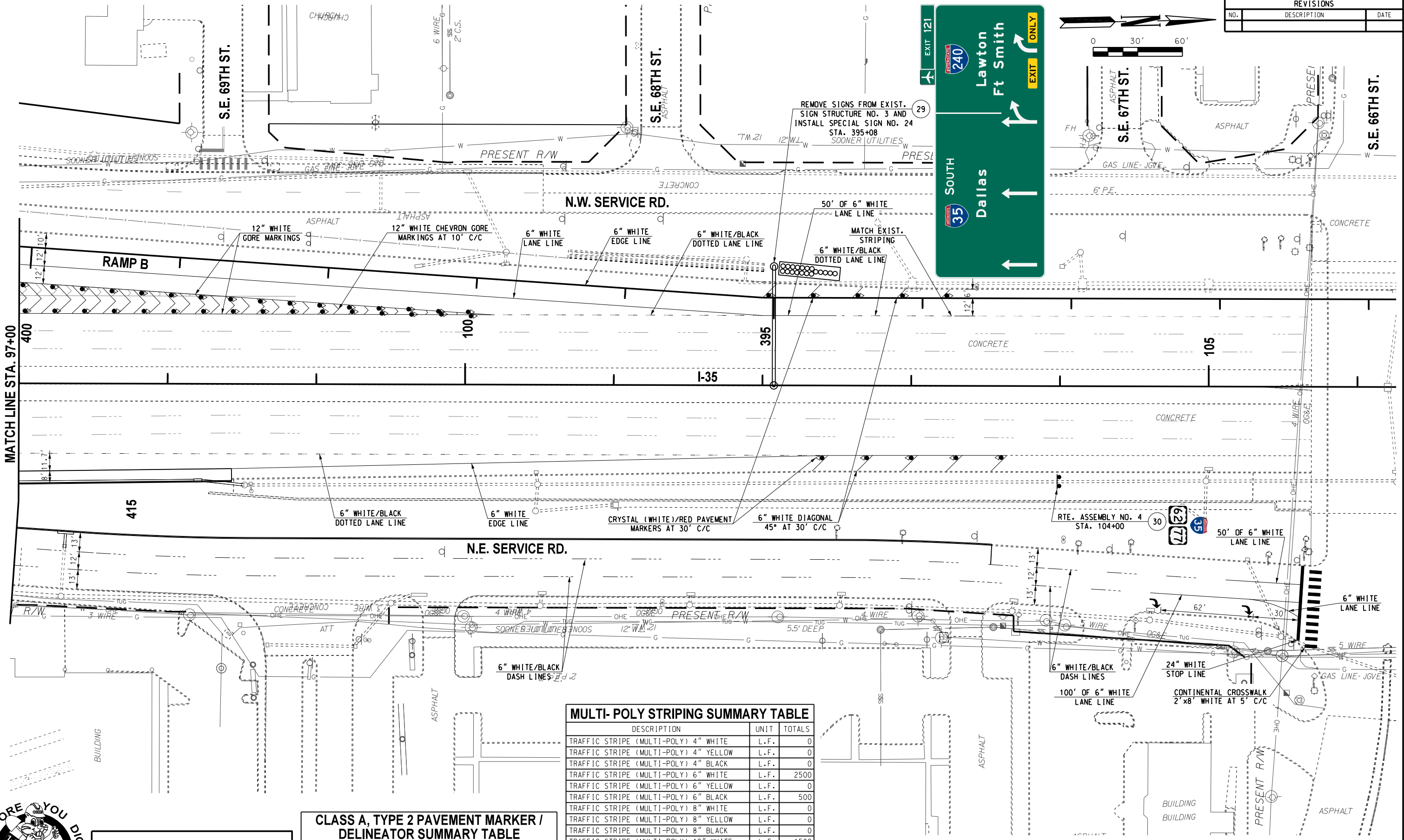

MULTI-POLY STRIPING SUMMARY TABLE		
DESCRIPTION	UNIT	TOTALS
TRAFFIC STRIPE (MULTI-POLY) 4" WHITE	L.F.	0
TRAFFIC STRIPE (MULTI-POLY) 4" YELLOW	L.F.	0
TRAFFIC STRIPE (MULTI-POLY) 4" BLACK	L.F.	0
TRAFFIC STRIPE (MULTI-POLY) 6" WHITE	L.F.	2500
TRAFFIC STRIPE (MULTI-POLY) 6" YELLOW	L.F.	0
TRAFFIC STRIPE (MULTI-POLY) 6" BLACK	L.F.	500
TRAFFIC STRIPE (MULTI-POLY) 8" WHITE	L.F.	0
TRAFFIC STRIPE (MULTI-POLY) 8" YELLOW	L.F.	0
TRAFFIC STRIPE (MULTI-POLY) 8" BLACK	L.F.	0
TRAFFIC STRIPE (MULTI-POLY) 12" WHITE	L.F.	1500
TRAFFIC STRIPE (MULTI-POLY) 12" YELLOW	L.F.	0
TRAFFIC STRIPE (MULTI-POLY) 12" BLACK	L.F.	0
TRAFFIC STRIPE (MULTI-POLY) 24" WHITE	L.F.	500
TRAFFIC STRIPE (MULTI-POLY) ARROWS	EA.	2
TRAFFIC STRIPE (MULTI-POLY) WORDS	EA.	0
TRAFFIC STRIPE (MULTI-POLY) SYMBOLS	EA.	0

CLASS A, TYPE 2 PAVEMENT MARKER / DELINEATOR SUMMARY TABLE		
DESCRIPTION	UNIT	TOTALS
◊ COLOR A - CRYSTAL/CRYSTAL (WHITE/WHITE)	EA.	0
◊ COLOR C - CRYSTAL/RED (WHITE/RED)	EA.	45
◊ COLOR D - AMBER/AMBER (YELLOW/YELLOW)	EA.	0
◊ COLOR E - AMBER/RED (YELLOW/RED)	EA.	0
▬ TYPE 1 - FLEXIBLE DRIVEABLE DELINEATOR	EA.	0

FOR MORE INFORMATION ON RAISED PAVEMENT MARKERS AND DELINEATORS, SEE TYPICAL DETAIL SHEETS.

CONTRACTOR TO REMOVE ALL CONFLICTING STRIPING.

Design MSH 03-12-24
Drawn SB 03-12-24



I-35 SIGNING & STRIPING
9 OF 10

State Job No. 09032(08) Sheet No. I053

OKLAHOMA COUNTY

03-12-24 G:\VOP\Projects\I-240\I-35 Phase IV - OKLA CAD\I053-0903208-135_SIGNING & STRIPING PLAN 9 OF 10.dgn



REVISIONS		
NO.	DESCRIPTION	DATE

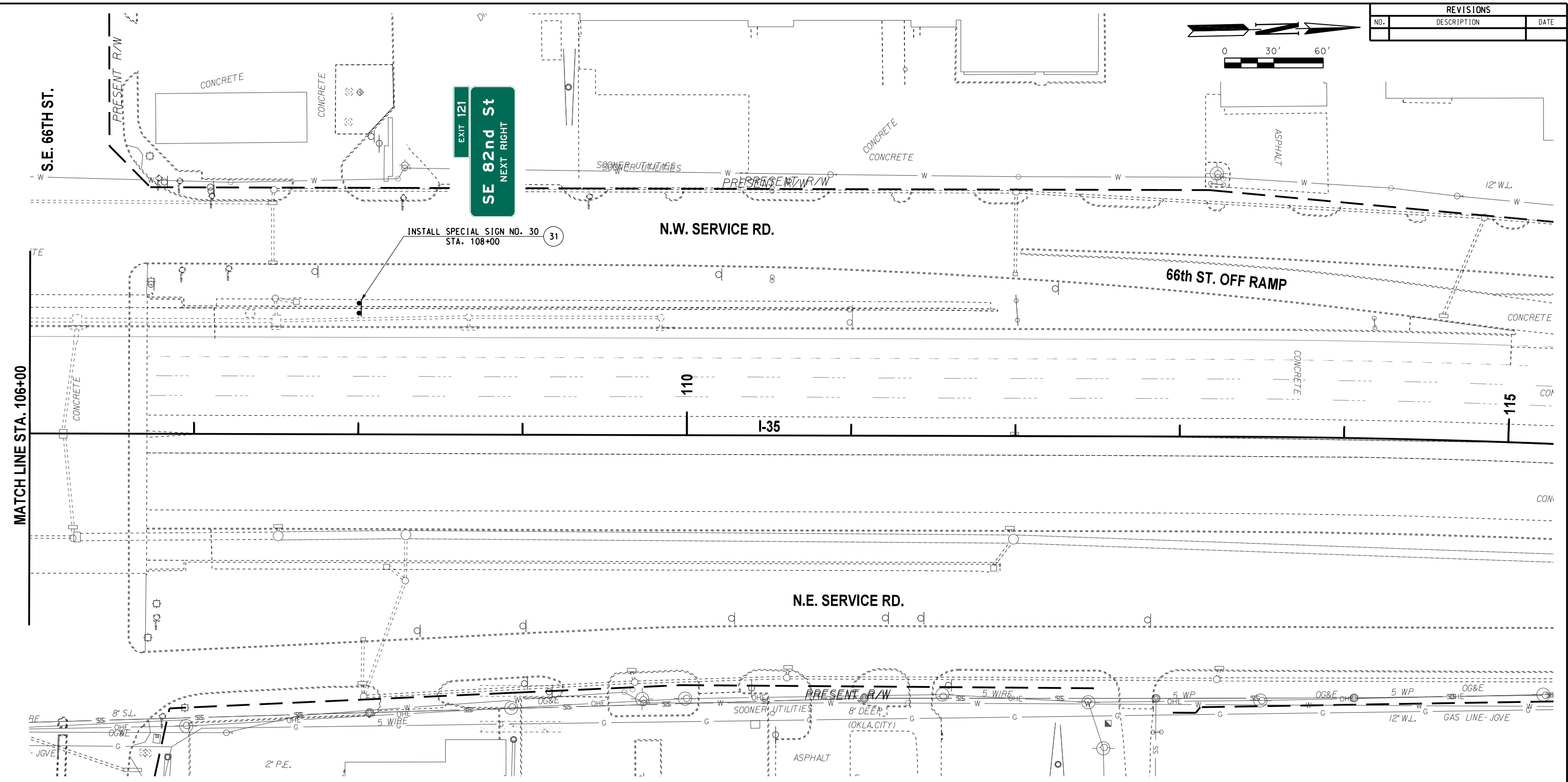
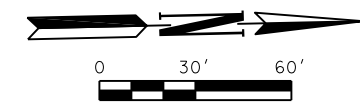

MATCH LINE STA. 106+00

MULTI-POLY STRIPING SUMMARY TABLE

DESCRIPTION	UNIT	TOTALS
TRAFFIC STRIPE (MULTI-POLY) 4" WHITE	L.F.	0
TRAFFIC STRIPE (MULTI-POLY) 4" YELLOW	L.F.	0
TRAFFIC STRIPE (MULTI-POLY) 4" BLACK	L.F.	0
TRAFFIC STRIPE (MULTI-POLY) 6" WHITE	L.F.	0
TRAFFIC STRIPE (MULTI-POLY) 6" YELLOW	L.F.	0
TRAFFIC STRIPE (MULTI-POLY) 6" BLACK	L.F.	0
TRAFFIC STRIPE (MULTI-POLY) 8" WHITE	L.F.	0
TRAFFIC STRIPE (MULTI-POLY) 8" YELLOW	L.F.	0
TRAFFIC STRIPE (MULTI-POLY) 8" BLACK	L.F.	0
TRAFFIC STRIPE (MULTI-POLY) 12" WHITE	L.F.	0
TRAFFIC STRIPE (MULTI-POLY) 12" YELLOW	L.F.	0
TRAFFIC STRIPE (MULTI-POLY) 12" BLACK	L.F.	0
TRAFFIC STRIPE (MULTI-POLY) 24" WHITE	L.F.	0
TRAFFIC STRIPE (MULTI-POLY) ARROWS	EA.	0
TRAFFIC STRIPE (MULTI-POLY) WORDS	EA.	0
TRAFFIC STRIPE (MULTI-POLY) SYMBOLS	EA.	0

CLASS A, TYPE 2 PAVEMENT MARKER / DELINEATOR SUMMARY TABLE

DESCRIPTION	UNIT	TOTALS
◊ COLOR A - CRYSTAL/CRYSTAL (WHITE/WHITE)	EA.	0
◊ COLOR C - CRYSTAL/RED (WHITE/RED)	EA.	0
◊ COLOR D - AMBER/AMBER (YELLOW/YELLOW)	EA.	0
◊ COLOR E - AMBER/RED (YELLOW/RED)	EA.	0
— TYPE 1 - FLEXIBLE DRIVEABLE DELINEATOR	EA.	0

FOR MORE INFORMATION ON RAISED PAVEMENT MARKERS AND DELINEATORS, SEE TYPICAL DETAIL SHEETS.



CONTRACTOR TO REMOVE ALL CONFLICTING STRIPING.

Design	MSH	03-12-24
Drawn	SB	03-12-24



I-35 SIGNING & STRIPING
10 OF 10

03-12-24 G:\V\Projects\T-2457E Design - I-35 Phase IV - OKLA CAD\T064-0903208-135_SIGNING & STRIPING PLAN ID 10.dgn

REVISIONS		
NO.	DESCRIPTION	DATE

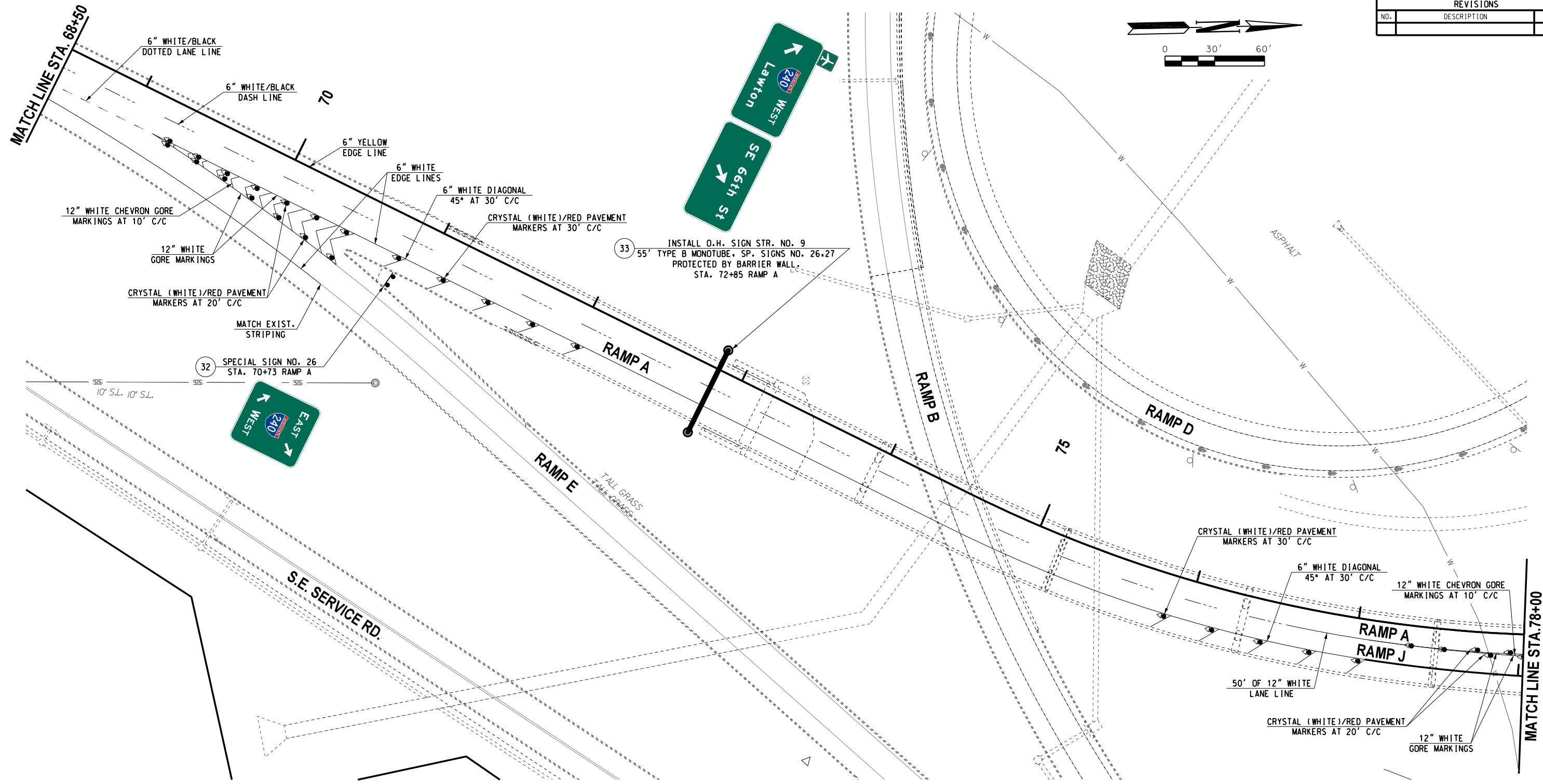
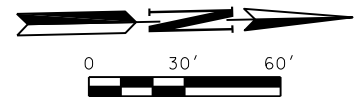

MULTI-POLY STRIPING SUMMARY TABLE

DESCRIPTION	UNIT	TOTALS
TRAFFIC STRIPE (MULTI-POLY) 4" WHITE	L.F.	0
TRAFFIC STRIPE (MULTI-POLY) 4" YELLOW	L.F.	0
TRAFFIC STRIPE (MULTI-POLY) 4" BLACK	L.F.	0
TRAFFIC STRIPE (MULTI-POLY) 6" WHITE	L.F.	2000
TRAFFIC STRIPE (MULTI-POLY) 6" YELLOW	L.F.	1000
TRAFFIC STRIPE (MULTI-POLY) 6" BLACK	L.F.	0
TRAFFIC STRIPE (MULTI-POLY) 8" WHITE	L.F.	0
TRAFFIC STRIPE (MULTI-POLY) 8" YELLOW	L.F.	0
TRAFFIC STRIPE (MULTI-POLY) 8" BLACK	L.F.	0
TRAFFIC STRIPE (MULTI-POLY) 12" WHITE	L.F.	500
TRAFFIC STRIPE (MULTI-POLY) 12" YELLOW	L.F.	0
TRAFFIC STRIPE (MULTI-POLY) 12" BLACK	L.F.	0
TRAFFIC STRIPE (MULTI-POLY) 24" WHITE	L.F.	0
TRAFFIC STRIPE (MULTI-POLY) ARROWS	EA.	0
TRAFFIC STRIPE (MULTI-POLY) WORDS	EA.	0
TRAFFIC STRIPE (MULTI-POLY) SYMBOLS	EA.	0

CLASS A, TYPE 2 PAVEMENT MARKER / DELINEATOR SUMMARY TABLE

DESCRIPTION	UNIT	TOTALS
◊ COLOR A - CRYSTAL/CRYSTAL (WHITE/WHITE)	EA.	0
◊ COLOR C - CRYSTAL/RED (WHITE/RED)	EA.	30
◊ COLOR D - AMBER/AMBER (YELLOW/YELLOW)	EA.	0
◊ COLOR E - AMBER/RED (YELLOW/RED)	EA.	0
— TYPE 1 - FLEXIBLE DRIVEABLE DELINEATOR	EA.	0

FOR MORE INFORMATION ON RAISED PAVEMENT MARKERS AND DELINEATORS, SEE TYPICAL DETAIL SHEETS.



CONTRACTOR TO REMOVE ALL CONFLICTING STRIPING.

Design	MSH	03-12-24
Drawn	SB	03-12-24



RAMP A SIGNING & STRIPING
1 OF 4

03-12-24 G:\09\Projects\T-2457E Design - I-240-I-35 Phase IV - OKLA CAD\T055-0903208-RAMP A SIGNING & STRIPING PLAN I OF 4.dgn

REVISIONS		
NO.	DESCRIPTION	DATE

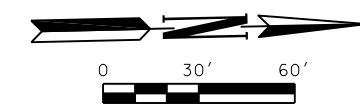
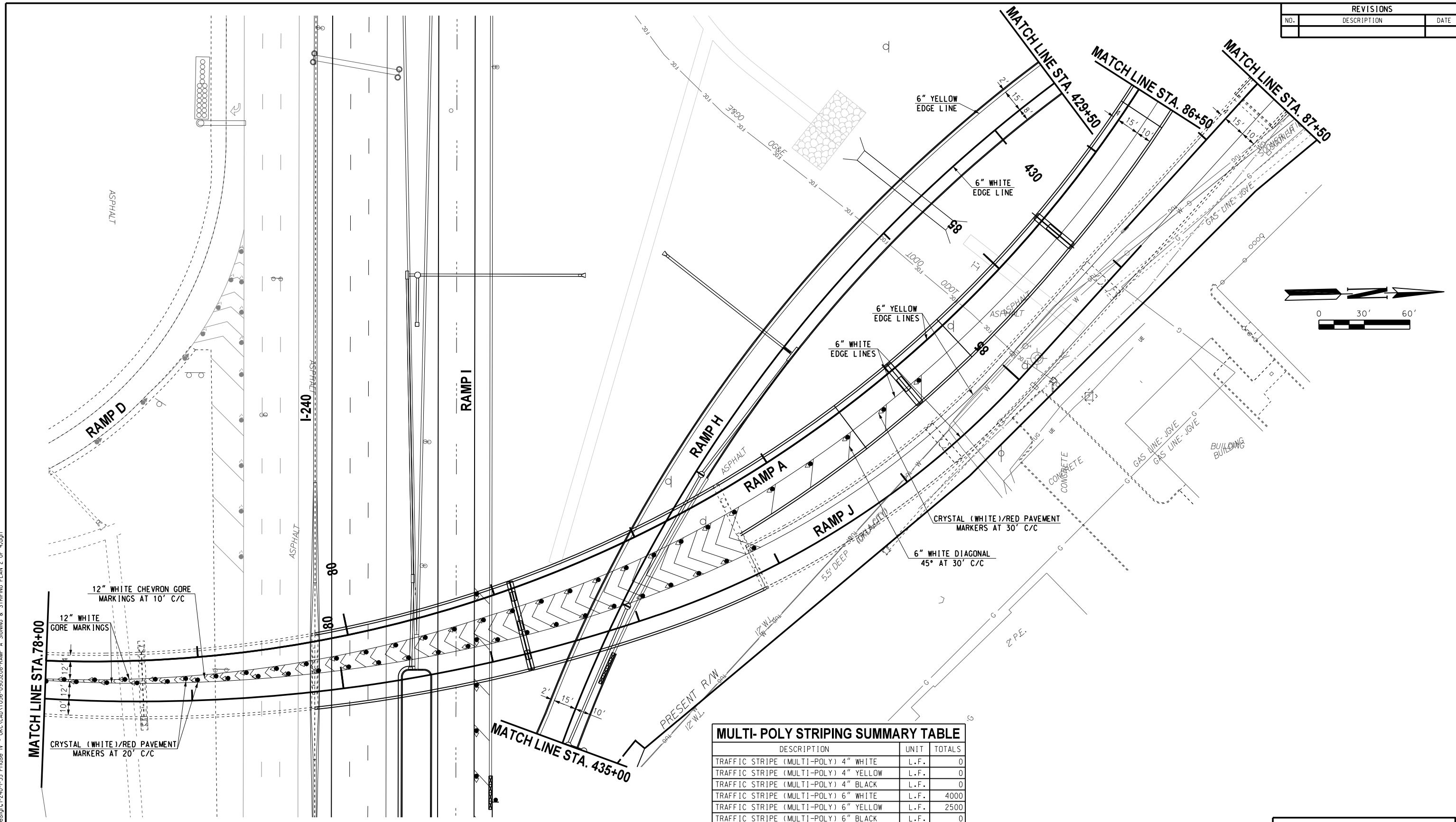

MULTI-POLY STRIPING SUMMARY TABLE

DESCRIPTION	UNIT	TOTALS
TRAFFIC STRIPE (MULTI-POLY) 4" WHITE	L.F.	0
TRAFFIC STRIPE (MULTI-POLY) 4" YELLOW	L.F.	0
TRAFFIC STRIPE (MULTI-POLY) 4" BLACK	L.F.	0
TRAFFIC STRIPE (MULTI-POLY) 6" WHITE	L.F.	4000
TRAFFIC STRIPE (MULTI-POLY) 6" YELLOW	L.F.	2500
TRAFFIC STRIPE (MULTI-POLY) 6" BLACK	L.F.	0
TRAFFIC STRIPE (MULTI-POLY) 8" WHITE	L.F.	0
TRAFFIC STRIPE (MULTI-POLY) 8" YELLOW	L.F.	0
TRAFFIC STRIPE (MULTI-POLY) 8" BLACK	L.F.	0
TRAFFIC STRIPE (MULTI-POLY) 12" WHITE	L.F.	1500
TRAFFIC STRIPE (MULTI-POLY) 12" YELLOW	L.F.	0
TRAFFIC STRIPE (MULTI-POLY) 12" BLACK	L.F.	0
TRAFFIC STRIPE (MULTI-POLY) 24" WHITE	L.F.	0
TRAFFIC STRIPE (MULTI-POLY) ARROWS	EA.	0
TRAFFIC STRIPE (MULTI-POLY) WORDS	EA.	0
TRAFFIC STRIPE (MULTI-POLY) SYMBOLS	EA.	0

CLASS A, TYPE 2 PAVEMENT MARKER / DELINEATOR SUMMARY TABLE

DESCRIPTION	UNIT	TOTALS
◊ COLOR A - CRYSTAL/CRYSTAL (WHITE/WHITE)	EA.	0
◊ COLOR C - CRYSTAL/RED (WHITE/RED)	EA.	60
◊ COLOR D - AMBER/AMBER (YELLOW/YELLOW)	EA.	0
◊ COLOR E - AMBER/RED (YELLOW/RED)	EA.	0
┌ TYPE 1 - FLEXIBLE DRIVEABLE DELINEATOR	EA.	0

FOR MORE INFORMATION ON RAISED PAVEMENT MARKERS AND DELINEATORS, SEE TYPICAL DETAIL SHEETS.

CONTRACTOR TO REMOVE ALL CONFLICTING STRIPING.



Design MSH 03-12-24
Drawn SB 03-12-24



RAMP A SIGNING & STRIPING
2 OF 4

State Job No. 09032(08) Sheet No. T056

03-12-24 G:\0\Projects\T-2457E Design-I-240-I-35 Phase IV - OKLAHOMA COUNTY-0903208-RAMP A SIGNING & STRIPING PLAN 2 OF 4.dgn

REVISIONS		
NO.	DESCRIPTION	DATE

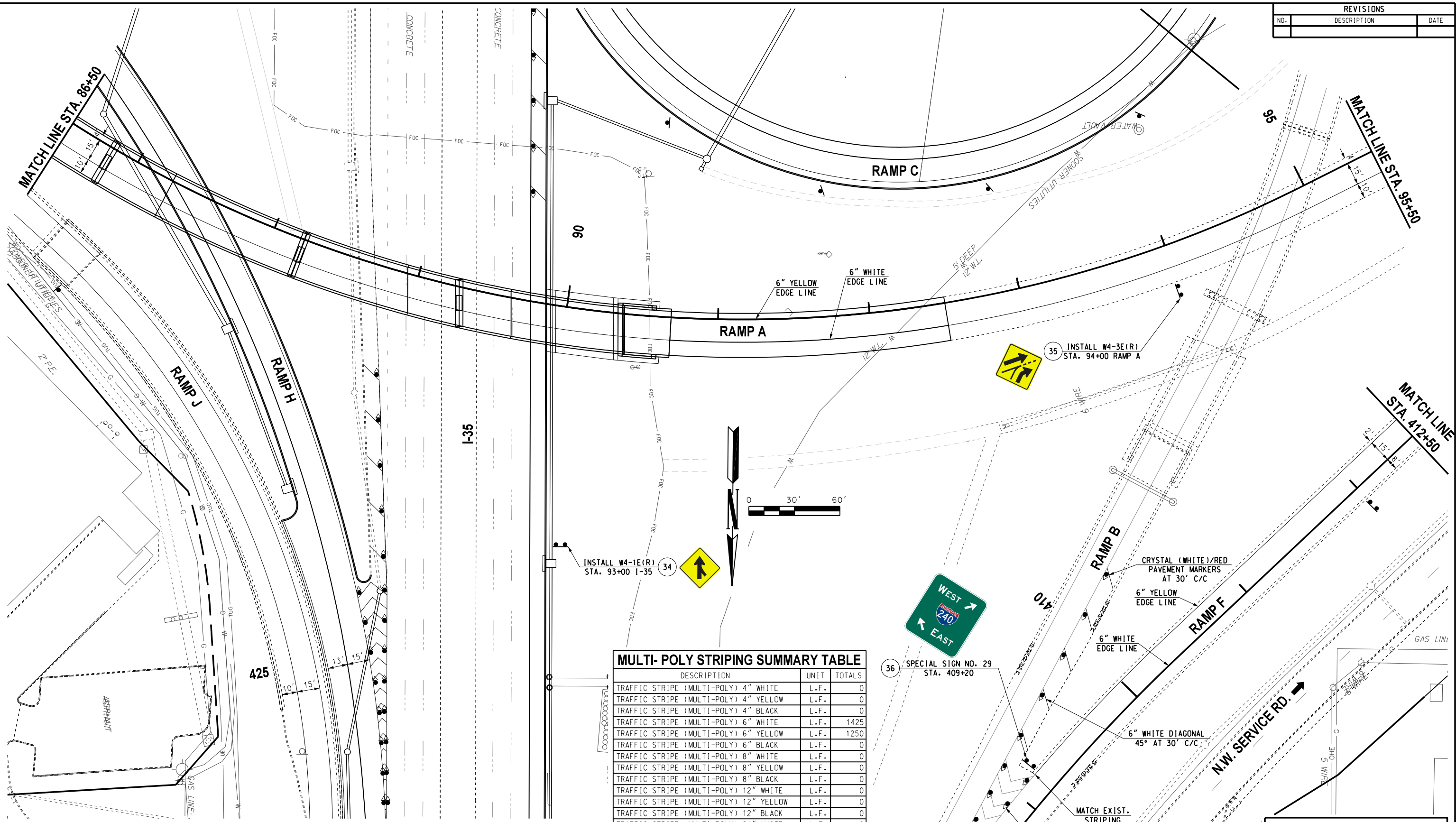

MULTI-POLY STRIPING SUMMARY TABLE

DESCRIPTION	UNIT	TOTALS
TRAFFIC STRIPE (MULTI-POLY) 4" WHITE	L.F.	0
TRAFFIC STRIPE (MULTI-POLY) 4" YELLOW	L.F.	0
TRAFFIC STRIPE (MULTI-POLY) 4" BLACK	L.F.	0
TRAFFIC STRIPE (MULTI-POLY) 6" WHITE	L.F.	1425
TRAFFIC STRIPE (MULTI-POLY) 6" YELLOW	L.F.	1250
TRAFFIC STRIPE (MULTI-POLY) 6" BLACK	L.F.	0
TRAFFIC STRIPE (MULTI-POLY) 8" WHITE	L.F.	0
TRAFFIC STRIPE (MULTI-POLY) 8" YELLOW	L.F.	0
TRAFFIC STRIPE (MULTI-POLY) 8" BLACK	L.F.	0
TRAFFIC STRIPE (MULTI-POLY) 12" WHITE	L.F.	0
TRAFFIC STRIPE (MULTI-POLY) 12" YELLOW	L.F.	0
TRAFFIC STRIPE (MULTI-POLY) 12" BLACK	L.F.	0
TRAFFIC STRIPE (MULTI-POLY) 24" WHITE	L.F.	0
TRAFFIC STRIPE (MULTI-POLY) ARROWS	EA.	0
TRAFFIC STRIPE (MULTI-POLY) WORDS	EA.	0
TRAFFIC STRIPE (MULTI-POLY) SYMBOLS	EA.	0

CLASS A, TYPE 2 PAVEMENT MARKER / DELINEATOR SUMMARY TABLE

DESCRIPTION	UNIT	TOTALS
◊ COLOR A - CRYSTAL/CRYSTAL (WHITE/WHITE)	EA.	0
◊ COLOR C - CRYSTAL/RED (WHITE/RED)	EA.	17
◊ COLOR D - AMBER/AMBER (YELLOW/YELLOW)	EA.	0
◊ COLOR E - AMBER/RED (YELLOW/RED)	EA.	0
— TYPE 1 - FLEXIBLE DRIVEABLE DELINEATOR	EA.	0

FOR MORE INFORMATION ON RAISED PAVEMENT MARKERS AND DELINEATORS, SEE TYPICAL DETAIL SHEETS.



CONTRACTOR TO REMOVE ALL CONFLICTING STRIPING.

Design MSH 03-12-24
Drawn SB 03-12-24



RAMP A SIGNING & STRIPING
3 OF 4

03-12-24 G:\VOP\Projects\T-2457E Design\I-240-I-35 Phase IV - OKLA CAD\T051-0903208-RAMP A SIGNING & STRIPING PLAN 3 OF 4.dgn

REVISIONS		
NO.	DESCRIPTION	DATE

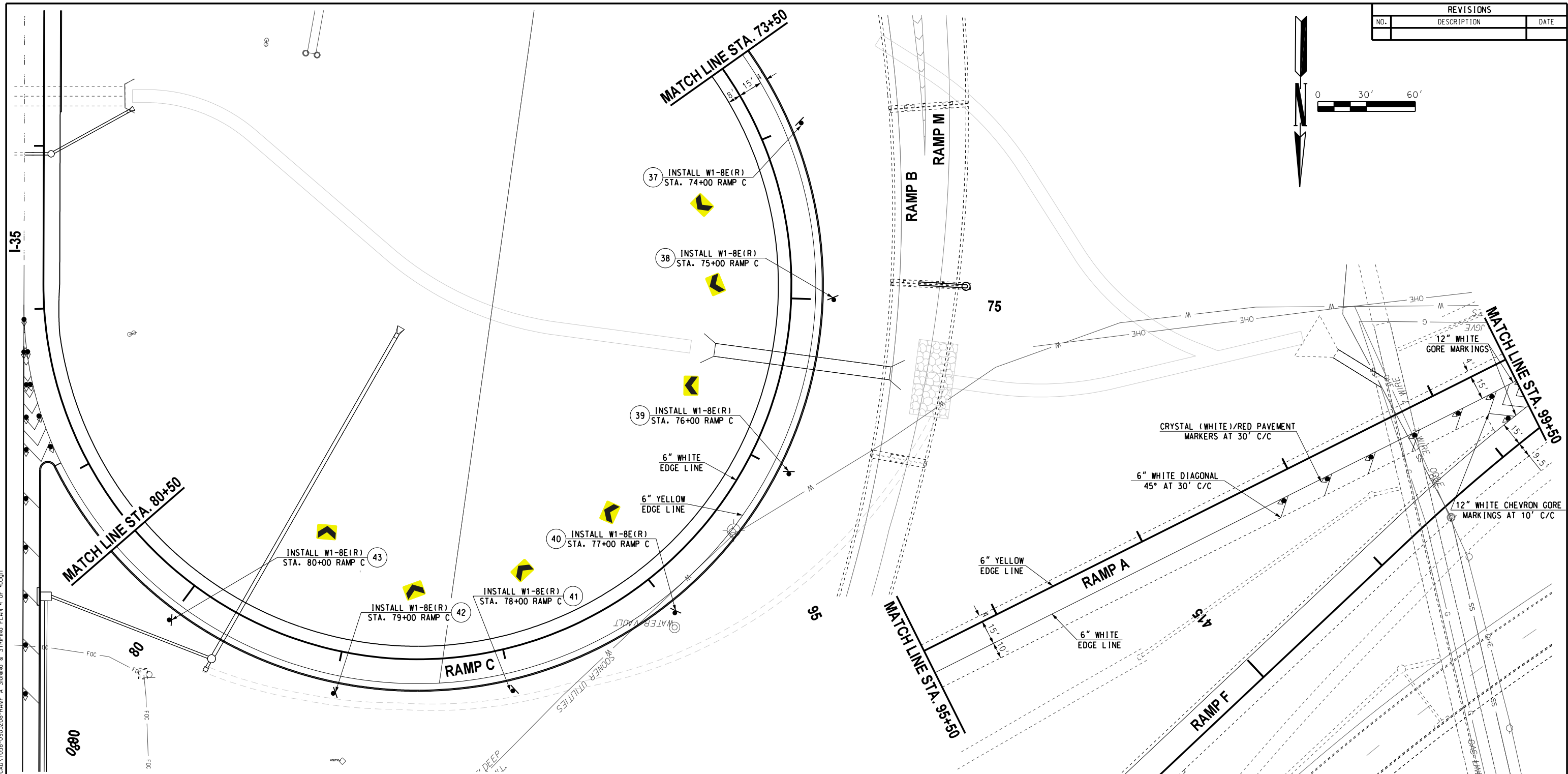
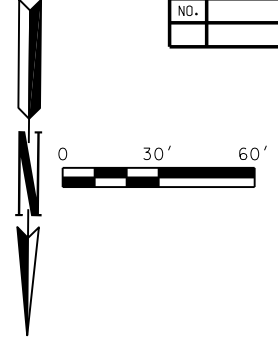

FOR MORE INFORMATION ON RAISED PAVEMENT MARKERS AND DELINEATORS, SEE TYPICAL DETAIL SHEETS.

DESCRIPTION	UNIT	TOTALS
◊ COLOR A - CRYSTAL/CRYSTAL (WHITE/WHITE)	EA.	0
◊ COLOR C - CRYSTAL/RED (WHITE/RED)	EA.	7
◊ COLOR D - AMBER/AMBER (YELLOW/YELLOW)	EA.	0
◊ COLOR E - AMBER/RED (YELLOW/RED)	EA.	0
▬ TYPE 1 - FLEXIBLE DRIVEABLE DELINEATOR	EA.	0

DESCRIPTION	UNIT	TOTALS
TRAFFIC STRIPE (MULTI-POLY) 4" WHITE	L.F.	0
TRAFFIC STRIPE (MULTI-POLY) 4" YELLOW	L.F.	0
TRAFFIC STRIPE (MULTI-POLY) 4" BLACK	L.F.	0
TRAFFIC STRIPE (MULTI-POLY) 6" WHITE	L.F.	1600
TRAFFIC STRIPE (MULTI-POLY) 6" YELLOW	L.F.	1600
TRAFFIC STRIPE (MULTI-POLY) 6" BLACK	L.F.	0
TRAFFIC STRIPE (MULTI-POLY) 8" WHITE	L.F.	0
TRAFFIC STRIPE (MULTI-POLY) 8" YELLOW	L.F.	0
TRAFFIC STRIPE (MULTI-POLY) 8" BLACK	L.F.	0
TRAFFIC STRIPE (MULTI-POLY) 12" WHITE	L.F.	150
TRAFFIC STRIPE (MULTI-POLY) 12" YELLOW	L.F.	0
TRAFFIC STRIPE (MULTI-POLY) 12" BLACK	L.F.	0
TRAFFIC STRIPE (MULTI-POLY) 24" WHITE	L.F.	0
TRAFFIC STRIPE (MULTI-POLY) ARROWS	EA.	0
TRAFFIC STRIPE (MULTI-POLY) WORDS	EA.	0
TRAFFIC STRIPE (MULTI-POLY) SYMBOLS	EA.	0

CONTRACTOR TO REMOVE ALL CONFLICTING STRIPING.



Design	MSH	03-12-24
Drawn	SB	03-12-24



RAMP A SIGNING & STRIPING
4 OF 4

State Job No. 09032(08) Sheet No. T058

03-12-24 G:\V\Projects\T-2457E Design - I-240-I-35 Phase IV - OKLAHOMA COUNTY - 0903208-RAMP A SIGNING & STRIPING PLAN 4 OF 4.dgn

REVISIONS		
NO.	DESCRIPTION	DATE

LIGHT POLE SCHEDULE

LOCATION			FOOTINGS				POLE ASSEMBLY							ODOT STANDARDS
SHEET NO.	POLE NO.	STATION	TYPE	48" DRILLED SHAFT 516(A) FT	CLASS 'A' CONC. 509(B) CY	REINF. STL 511(A) LB	B. BASE DESIGN NO.	POLE LENGTH FT	ARM NO. 1 FT	ARM NO. 2 FT	NO. OF LUMINAIRES AND WATTS	IES DIST. TYPE	1/C NO 12 AWG TYPE THW FT	
	1	AS SHOWN CL (MAINLINE I-35)	DRILLED SHAFT	30				140' HIGH MAST POLE	N/A	N/A	6 - 1000	MS4	250	1
	2	AS SHOWN CL (MAINLINE I-35)	DRILLED SHAFT	30				140' HIGH MAST POLE	N/A	N/A	6 - 1000	MS4	250	1
	3	AS SHOWN CL (MAINLINE I-35)	DRILLED SHAFT	30				140' HIGH MAST POLE	N/A	N/A	6 - 1000	MS3	125	1
	4	AS SHOWN (N SERVICE RD)	DRILLED SHAFT	30				140' HIGH MAST POLE	N/A	N/A	6 - 1000	MS3	125	1
	5	AS SHOWN CL (MAINLINE I-240)	DRILLED SHAFT	30				140' HIGH MAST POLE	N/A	N/A	4 - 1000	MS4	250	1
	6	AS SHOWN CL (N SERVICE RD)	DRILLED SHAFT	30				140' HIGH MAST POLE	N/A	N/A	4 - 1000	MS3	125	1
	7	AS SHOWN CL (S SERVICE RD)	DRILLED SHAFT	30				140' HIGH MAST POLE	N/A	N/A	6 - 1000	MS3	125	1
	8	AS SHOWN CL (MAINLINE I-240)	DRILLED SHAFT	30				140' HIGH MAST POLE	N/A	N/A	4 - 1000	MS4	250	1
	9	AS SHOWN CL (N SERVICE RD)	DRILLED SHAFT	30				140' HIGH MAST POLE	N/A	N/A	4 - 1000	MS3	125	1
	10	AS SHOWN CL (S SERVICE RD)	DRILLED SHAFT	30				140' HIGH MAST POLE	N/A	N/A	4 - 1000	MS3	125	1
	11	AS SHOWN CL (MAINLINE I-240)	DRILLED SHAFT	30				140' HIGH MAST POLE	N/A	N/A	4 - 1000	MS4	250	1
	12	AS SHOWN CL (N SERVICE RD)	DRILLED SHAFT	30				140' HIGH MAST POLE	N/A	N/A	4 - 1000	MS3	125	1
	13	AS SHOWN CL (MAINLINE I-240)	DRILLED SHAFT	30				140' HIGH MAST POLE	N/A	N/A	6 - 1000	MS4	250	1
	14	AS SHOWN CL (MAINLINE I-240)	DRILLED SHAFT	30				140' HIGH MAST POLE	N/A	N/A	2 - 1000	MS4	250	1
	15	AS SHOWN CL (MAINLINE I-240)	DRILLED SHAFT	30				140' HIGH MAST POLE	N/A	N/A	2 - 1000	MS4	250	1
	16	AS SHOWN CL (MAINLINE I-240)	DRILLED SHAFT	30				140' HIGH MAST POLE	N/A	N/A	4 - 1000	MS4	250	1
	23	AS SHOWN CL (MAINLINE I-240)	SEE DETAIL	SPREAD	2.81	470		36	N/A	N/A	4 - 1000	MS4	250	1
	24	AS SHOWN CL (MAINLINE I-240)	SEE DETAIL	SPREAD	2.81	470		36	N/A	N/A	2 - 245	MS4	250	1
	25	AS SHOWN CL (MAINLINE I-240)	SEE DETAIL	SPREAD	2.81	470		36	N/A	N/A	2 - 245	MS4	250	1
	26	AS SHOWN CL (MAINLINE I-240)	SEE DETAIL	SPREAD	2.81	470		36	N/A	N/A	2 - 245	MS4	250	1
	27	AS SHOWN CL (MAINLINE I-240)	SEE DETAIL	SPREAD	2.81	470		36	N/A	N/A	2 - 245	MS4	250	1
	28	AS SHOWN CL (MAINLINE I-240)	SEE DETAIL	SPREAD	2.81	470		36	N/A	N/A	2 - 245	MS4	250	1
	29	AS SHOWN CL (MAINLINE I-240)	SEE DETAIL	SPREAD	2.81	470		36	N/A	N/A				
	30	AS SHOWN CL (MAINLINE I-240)	SEE DETAIL	SPREAD	2.81	470		36	N/A	N/A				
	31	AS SHOWN CL (MAINLINE I-240)	SEE DETAIL	SPREAD	2.81	470		36	N/A	N/A				
	32	AS SHOWN CL (MAINLINE I-240)	SEE DETAIL	SPREAD	2.81	470		36	N/A	N/A				
	33	AS SHOWN CL (MAINLINE I-240)	SEE DETAIL	SPREAD	2.81	470		36	N/A	N/A				
	34	AS SHOWN CL (MAINLINE I-240)	SEE DETAIL	SPREAD	2.81	470		36	N/A	N/A				
TOTALS				480.00	33.72	5640.00		12 - 36' OVAL POLES	16 - 140' HIGH MAST POLES		86 HIGH MAST LUMINAIRES 10 RDY LUMINAIRES		4625	22

03-12-24 G:\Projects\1-245\TE Design\I-240-I-35 Phase IV - OKLA CAD\T059-0903208-LIGHTING SCHEDULES.dgn

Design	MSH	03-12-24
Drawn	SB	03-12-24



LIGHTING SCHEDULES

State Job No. 09032(08) Sheet No. T059

REVISIONS		
NO.	DESCRIPTION	DATE

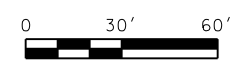

EXISTING SERVICE POLE FOR CIRCUIT B IS LOCATED ON THE N.E. CORNER OF SHIELDS BLVD. & N.W. SERVICE ROAD

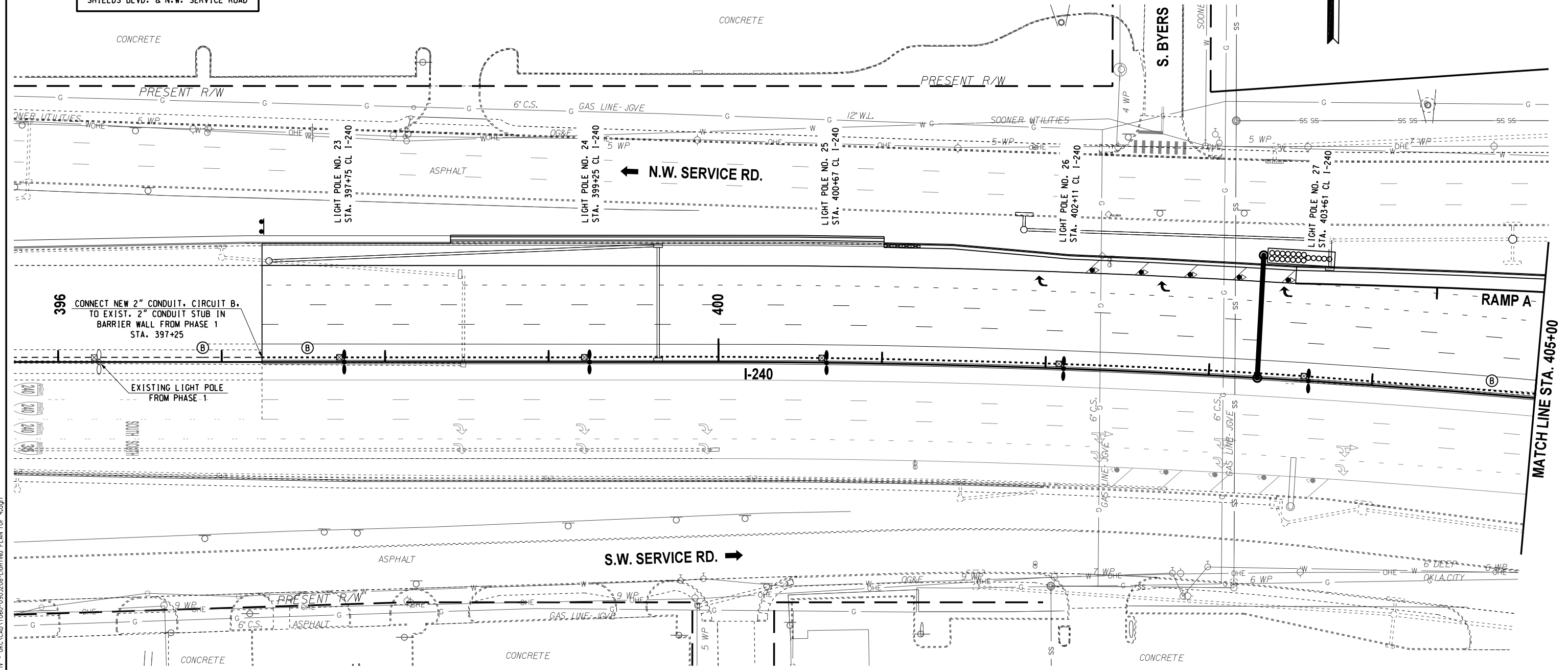

396 CONNECT NEW 2" CONDUIT, CIRCUIT B. TO EXIST. 2" CONDUIT STUB IN BARRIER WALL FROM PHASE 1 STA. 397+25

EXISTING LIGHT POLE FROM PHASE 1

LEGEND

- 1 1/4" ELECT. CONDUIT (EXPOSED)
- - - 2" ELECT. PVC CONDUIT (TRENCHED)
- 2" ELECT. CONDUIT (BORED)
- - - EXISTING CONDUIT
- SIZE 1 PULL BOX
- ▲ SPECIAL MED. BARRIER PULL BOX
- ⊕ ELECTRIC SERVICE LOCATION
- Ⓟ CIRCUIT DESIGNATION
- ⬇ UNDERPASS LUMINAIRE
- ⊕ TWIN MAST ARM LIGHT POLES W/ BREAKAWAY BASE
- ⊕ TWIN MAST ARM LIGHT POLES W/O BREAKAWAY BASE
- ⊕ LIGHT POLE W/ BREAKAWAY BASE
- ⊕ LIGHT POLE W/O BREAKAWAY BASE
- ⊕ HIGH MAST TOWER LIGHT POLE

03-12-24 G:\V\Projects\1-2457E Design\1-240-1-35 Phase IV - OKLA CAD\T060-0903208-LIGHTING PLAN 1 OF 4.dgn



Design	MSH	03-12-24
Drawn	SB	03-12-24



LIGHTING PLAN
1 OF 4

REVISIONS		
NO.	DESCRIPTION	DATE

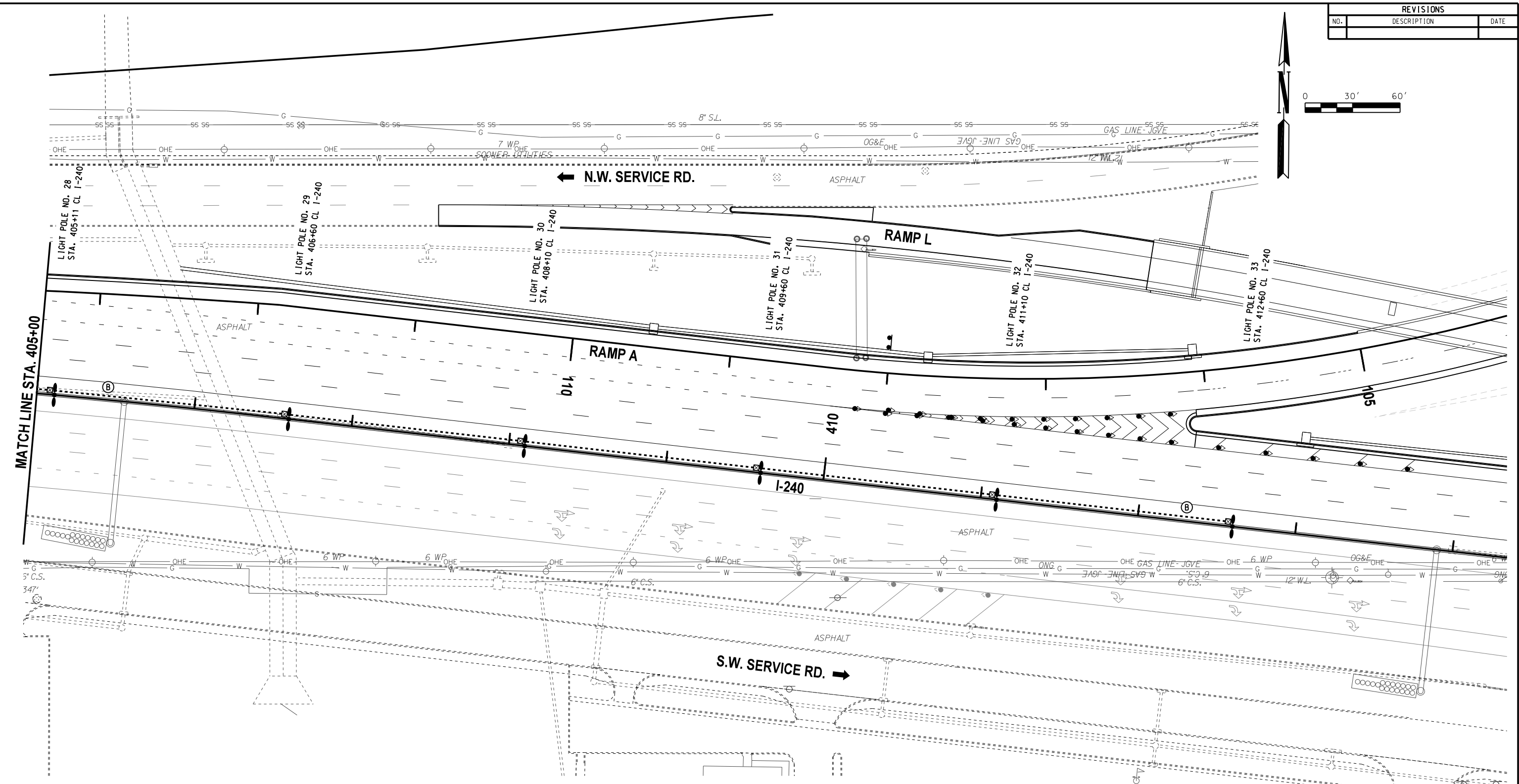
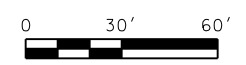

LEGEND	
	1 1/4" ELECT. CONDUIT (EXPOSED)
	2" ELECT. PVC CONDUIT (TRENCHED)
	2" ELECT. CONDUIT (BORED)
	EXISTING CONDUIT
	SIZE 1 PULL BOX
	SPECIAL MED. BARRIER PULL BOX
	ELECTRIC SERVICE LOCATION
	CIRCUIT DESIGNATION
	UNDERPASS LUMINAIRE
	TWIN MAST ARM LIGHT POLES W/ BREAKAWAY BASE
	TWIN MAST ARM LIGHT POLES W/O BREAKAWAY BASE
	LIGHT POLE W/ BREAKAWAY BASE
	LIGHT POLE W/O BREAKAWAY BASE
	HIGH MAST TOWER LIGHT POLE



Design	MSH	03-12-24
Drawn	SB	03-12-24



LIGHTING PLAN
2 OF 4

State Job No. 09032(08) Sheet No. T061

03-12-24 G:\V\Projects\T-245\TE Design - OKLA CAD\T061-0903208-LIGHTING PLAN 2 OF 4.dgn

REVISIONS		
NO.	DESCRIPTION	DATE

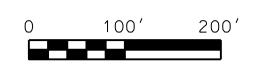

LEGEND	
---	1 1/2" ELECT. CONDUIT (EXPOSED)
- - -	2" ELECT. PVC CONDUIT (TRENCHED)
- - -	2" ELECT. CONDUIT (BORED)
- - -	EXISTING CONDUIT
□	SIZE 1 PULL BOX
▲	SPECIAL MED. BARRIER PULL BOX
⊠	ELECTRIC SERVICE LOCATION
Ⓟ	CIRCUIT DESIGNATION
⌞	UNDERPASS LUMINAIRE
⌞	TWIN MAST ARM LIGHT POLES W/ BREAKAWAY BASE
⌞	TWIN MAST ARM LIGHT POLES W/O BREAKAWAY BASE
⌞	LIGHT POLE W/ BREAKAWAY BASE
⌞	LIGHT POLE W/O BREAKAWAY BASE
⊗	HIGH MAST TOWER LIGHT POLE
*	EXISTING LIGHT POLE REMOVAL

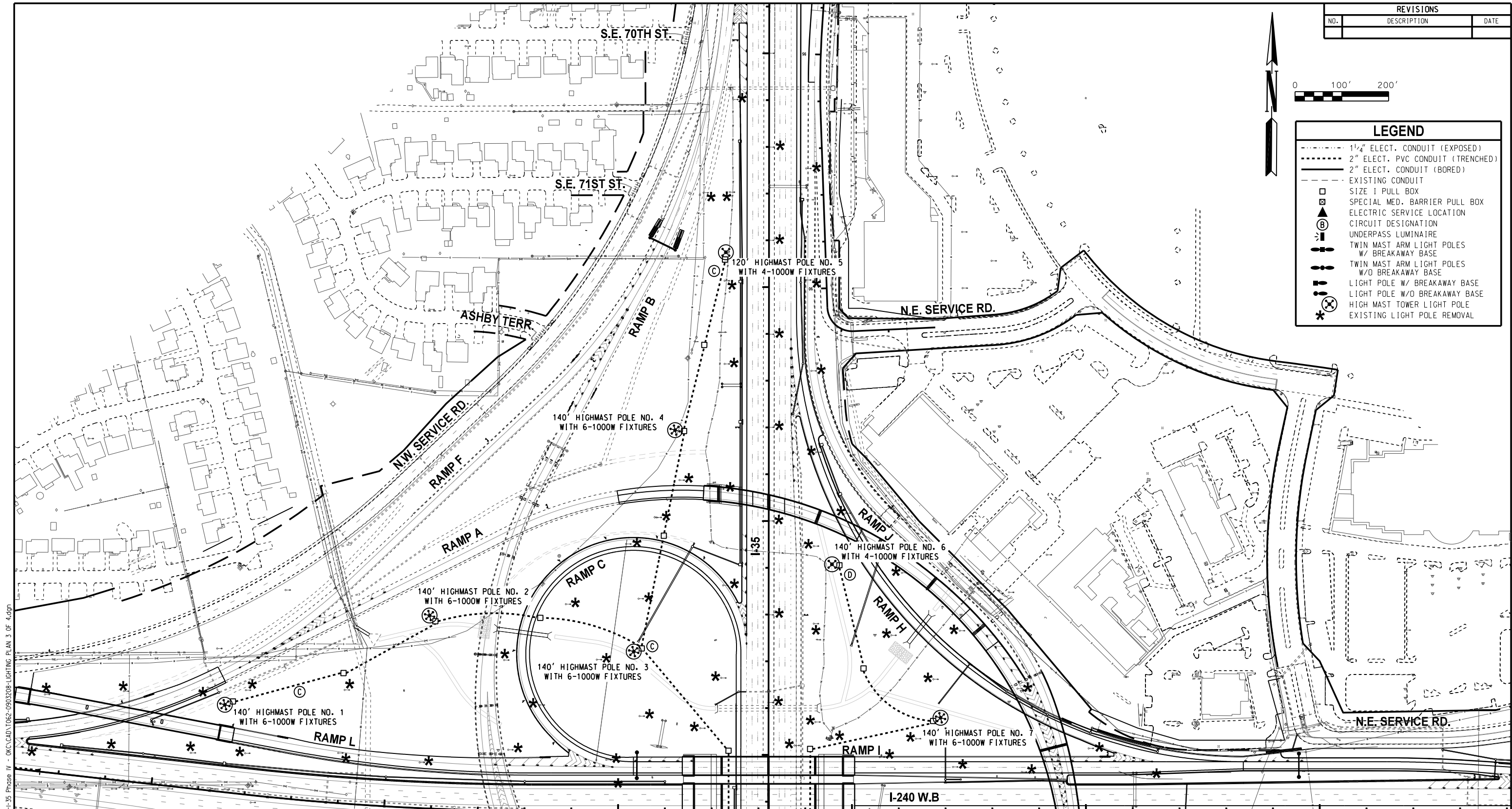

MATCH LINE "A"

MATCH LINE "A"

03-12-24 G:\V\Projects\T-2457E Design\I-240-I-35 Phase IV - OKLA CAD\T062-0903208-LIGHTING PLAN 3 OF 4.dgn



Design	MSH	03-12-24
Drawn	SB	03-12-24



LIGHTING PLAN
3 OF 4

State Job No. 09032(08) Sheet No. T062

OKLAHOMA COUNTY

REVISIONS		
NO.	DESCRIPTION	DATE

MATCH LINE "A"

MATCH LINE "A"

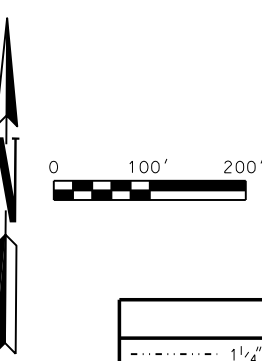
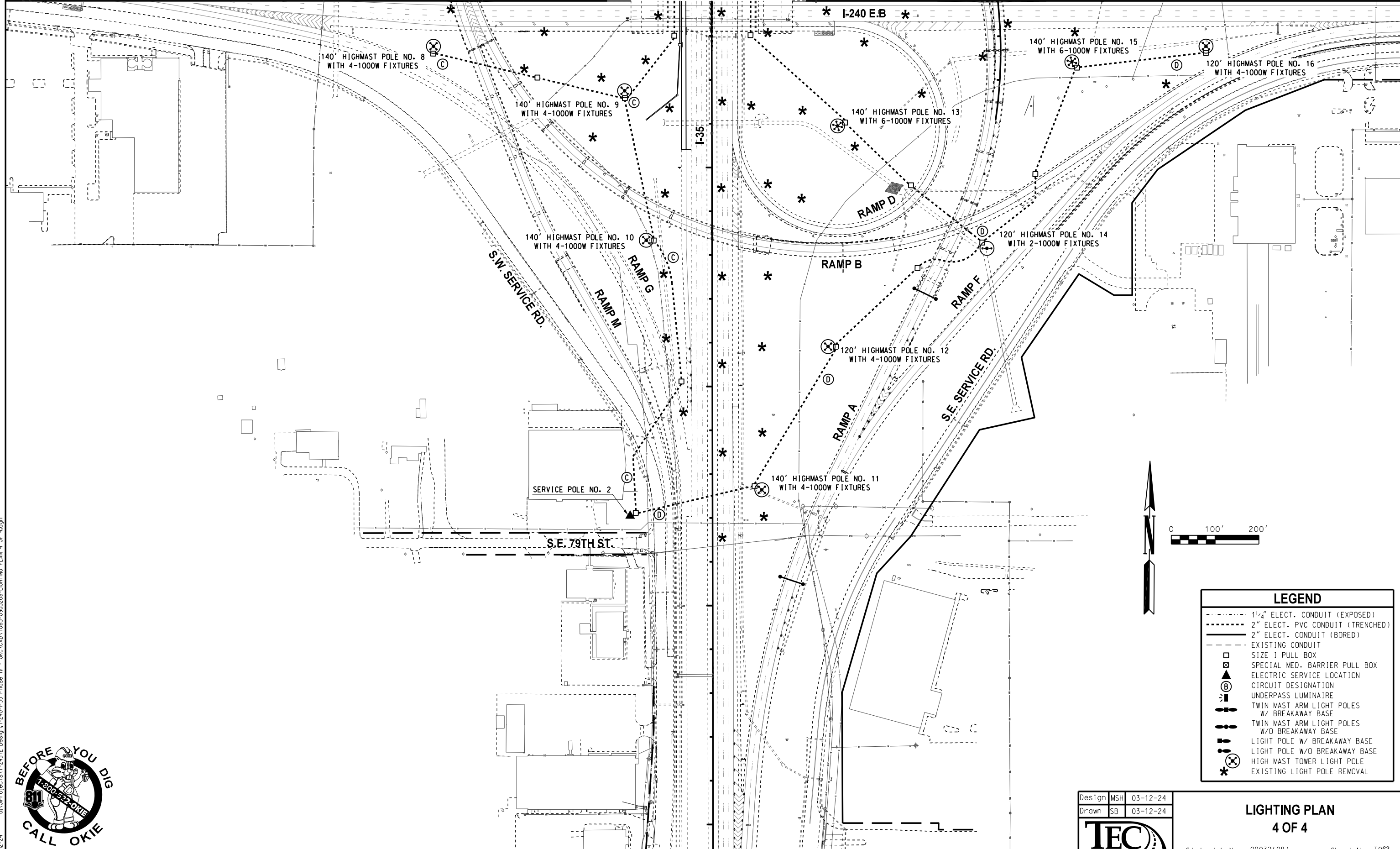

LEGEND	
	1 1/2" ELECT. CONDUIT (EXPOSED)
	2" ELECT. PVC CONDUIT (TRENCHED)
	2" ELECT. CONDUIT (BORED)
	EXISTING CONDUIT
	SIZE 1 PULL BOX
	SPECIAL MED. BARRIER PULL BOX
	ELECTRIC SERVICE LOCATION
	CIRCUIT DESIGNATION
	UNDERPASS LUMINAIRE
	TWIN MAST ARM LIGHT POLES W/ BREAKAWAY BASE
	TWIN MAST ARM LIGHT POLES W/O BREAKAWAY BASE
	LIGHT POLE W/ BREAKAWAY BASE
	LIGHT POLE W/O BREAKAWAY BASE
	HIGH MAST TOWER LIGHT POLE
	EXISTING LIGHT POLE REMOVAL

Design	MSH	03-12-24
Drawn	SB	03-12-24



LIGHTING PLAN
4 OF 4

03-12-24 G:\V\Projects\T-2457E Design IV - OKLA\CAD\T063-0903208-LIGHTING PLAN 4 OF 4.dgn



REVISIONS		
NO.	DESCRIPTION	DATE

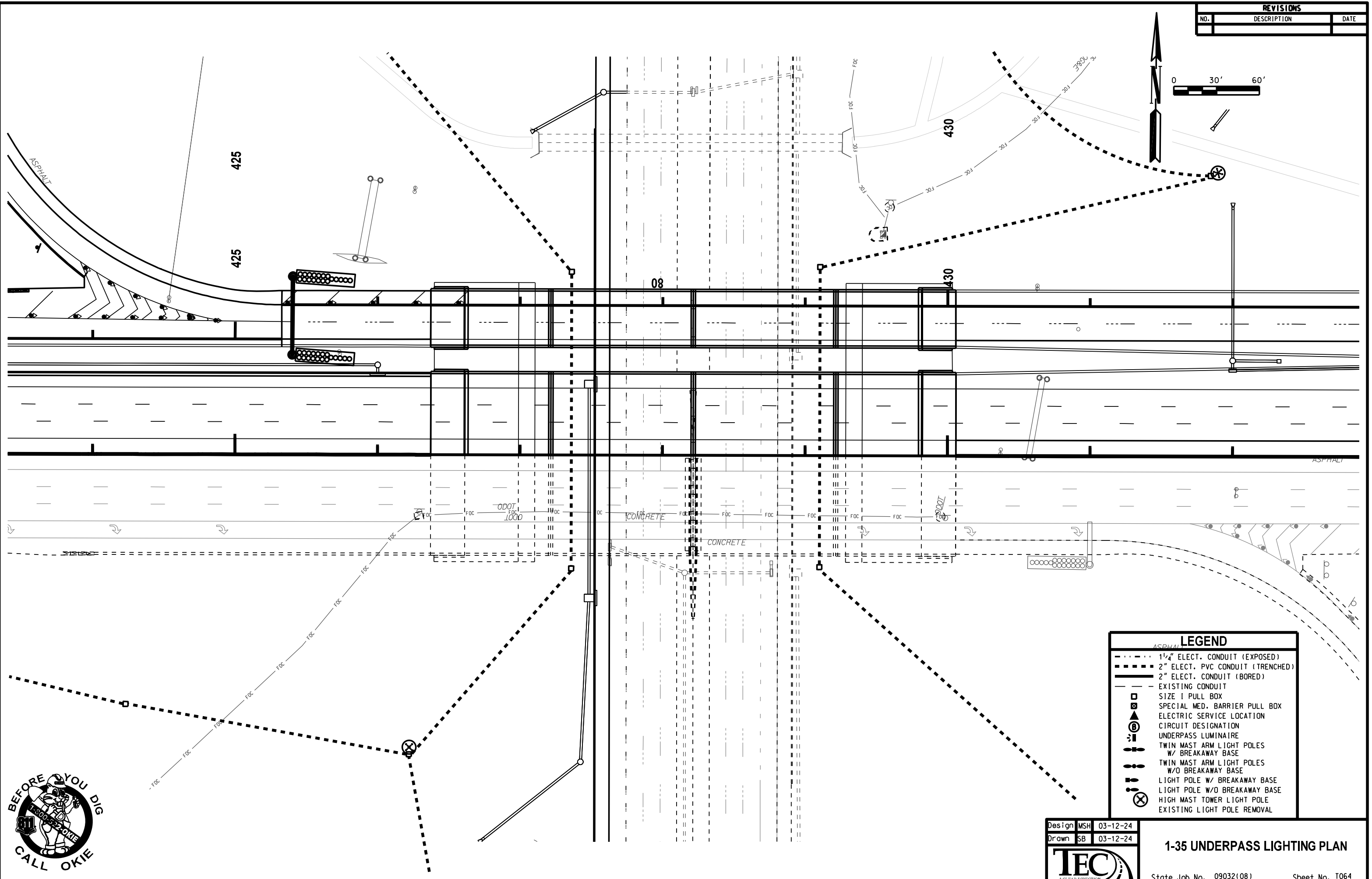
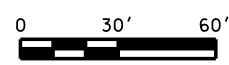

LEGEND	
	1 1/2" ELECT. CONDUIT (EXPOSED)
	2" ELECT. PVC CONDUIT (TRENCHED)
	2" ELECT. CONDUIT (BORED)
	EXISTING CONDUIT
	SIZE I PULL BOX
	SPECIAL MED. BARRIER PULL BOX
	ELECTRIC SERVICE LOCATION
	CIRCUIT DESIGNATION
	UNDERPASS LUMINAIRE
	TWIN MAST ARM LIGHT POLES W/ BREAKAWAY BASE
	TWIN MAST ARM LIGHT POLES W/O BREAKAWAY BASE
	LIGHT POLE W/ BREAKAWAY BASE
	LIGHT POLE W/O BREAKAWAY BASE
	HIGH MAST TOWER LIGHT POLE
	EXISTING LIGHT POLE REMOVAL

Design MSH 03-12-24
 Drawn SB 03-12-24



1-35 UNDERPASS LIGHTING PLAN

G:\09-Projects\1-35\1-35 Phase IV - OKC\CAD\T064-0903208-135 UNDERPASS LIGHTING PLAN.dgn
 03-12-24



(CAUTION) THE LOCATION OF ALL UTILITIES AS SHOWN ARE APPROXIMATE. DUE TO RELOCATION'S PLANNED OR PRESENTLY UNDER CONSTRUCTION THERE ARE SOME UTILITIES THAT WILL BE RELOCATED AND NOT SHOWN ON THESE PLANS. THE CONTRACTOR SHALL BE RESPONSIBLE FOR ANY DAMAGE TO ALL UTILITIES. DEPTH & LOCATION OF EXISTING UTILITIES SHALL BE FIELD VERIFIED BY THE CONTRACTOR PRIOR TO CONSTRUCTION.

SEE DRAINAGE AREA MAP SHEETS FOR DRAINAGE SYMBOLOLOGY.

R/W & U/E PURCHASED UNDER JP 09032(05)

POB & ASSOCIATES, OKLAHOMA CITY, OK.

**90% PLAN
SUBMITTAL**

3/4/2024

AREA
CUT FILL

VOLUME
CUT FILL

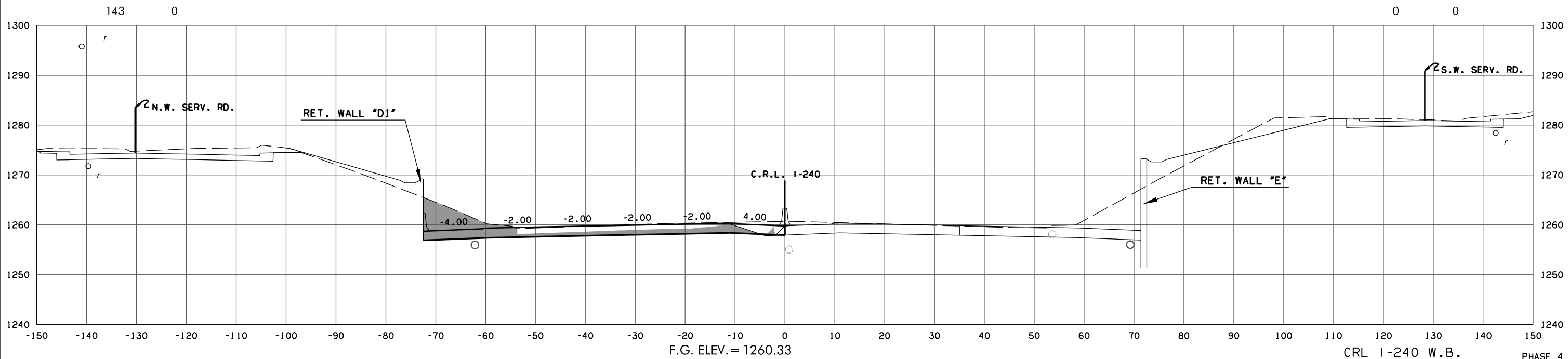
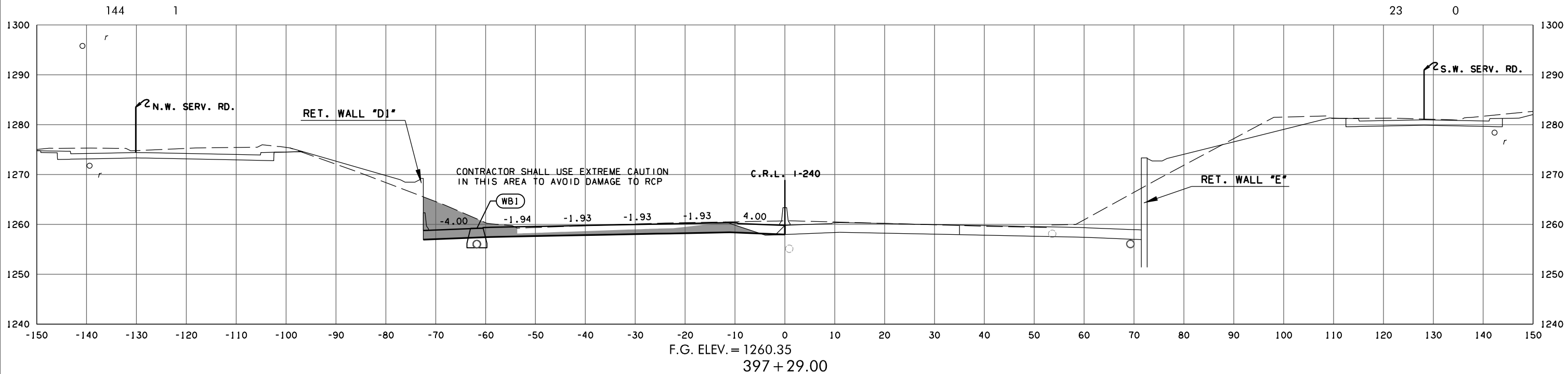

EGIN SU ER ROT TION EGIN CONSTRUCTION

CRL I-240 W.B. PHASE 4
STATE JOB NO. 09032(08)
OKLAHOMA COUNTY SHEET NO. X001

3/4/2024 3:53:58 PM H:\PROJECTS\2789_CrossRoads_Phase 4\Roadway\Drawings\Sections\0903208-XSEC.CRL - 240.dgn

(CAUTION) THE LOCATION OF ALL UTILITIES AS SHOWN ARE APPROXIMATE. DUE TO RELOCATION'S PLANNED OR PRESENTLY UNDER CONSTRUCTION THERE ARE SOME UTILITIES THAT WILL BE RELOCATED AND NOT SHOWN ON THESE PLANS. THE CONTRACTOR SHALL BE RESPONSIBLE FOR ANY DAMAGE TO ALL UTILITIES. DEPTH & LOCATION OF EXISTING UTILITIES SHALL BE FIELD VERIFIED BY THE CONTRACTOR PRIOR TO CONSTRUCTION.

SEE DRAINAGE AREA MAP SHEETS FOR DRAINAGE SYMBOLOLOGY.

R/W & U/E PURCHASED UNDER JP 09032(05)

POB & ASSOCIATES, OKLAHOMA CITY, OK.

**90% PLAN
SUBMITTAL**

3/4/2024

AREA
CUT FILL

VOLUME
CUT FILL

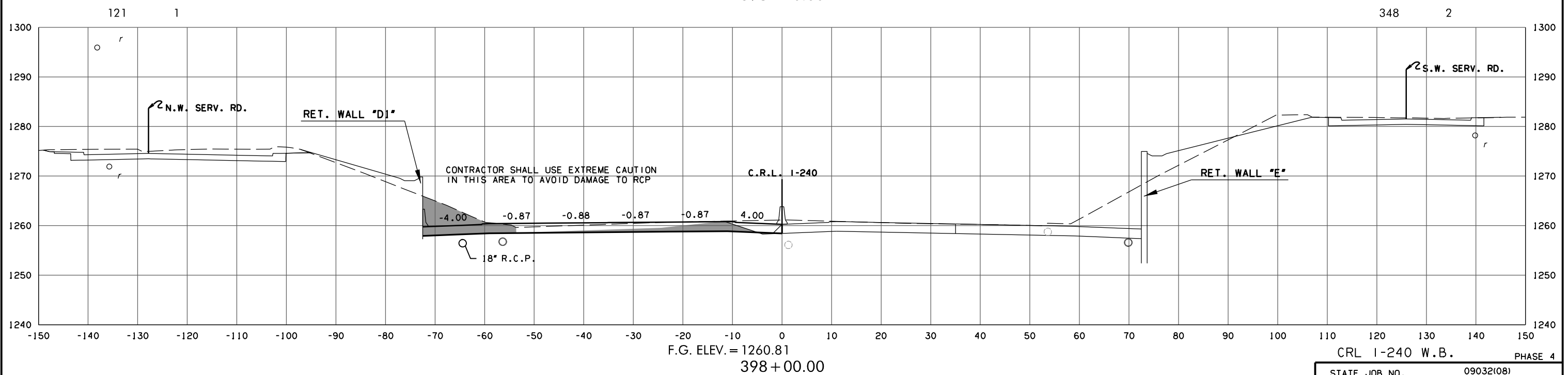
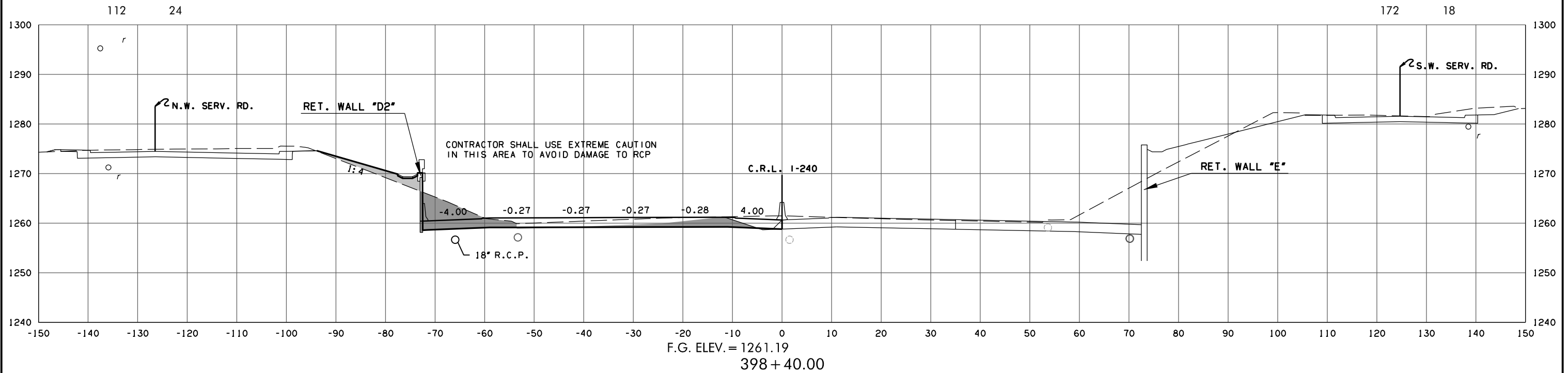

3/4/2024 3:54:00 PM H:\PROJECTS\2789_CrossRoads_Phase 4\Roadway\Drawings\Sections\0903208-XSEC.CRL - 240.dgn

CRL 1-240 W.B. PHASE 4
STATE JOB NO. 09032(08)
OKLAHOMA COUNTY SHEET NO. X002

[CAUTION] THE LOCATION OF ALL UTILITIES AS SHOWN ARE APPROXIMATE. DUE TO RELOCATION'S PLANNED OR PRESENTLY UNDER CONSTRUCTION THERE ARE SOME UTILITIES THAT WILL BE RELOCATED AND NOT SHOWN ON THESE PLANS. THE CONTRACTOR SHALL BE RESPONSIBLE FOR ANY DAMAGE TO ALL UTILITIES. DEPTH & LOCATION OF EXISTING UTILITIES SHALL BE FIELD VERIFIED BY THE CONTRACTOR PRIOR TO CONSTRUCTION.

SEE DRAINAGE AREA MAP SHEETS FOR DRAINAGE SYMBOLOLOGY.

R/W & U/E PURCHASED UNDER JP 09032(05)

POB & ASSOCIATES, OKLAHOMA CITY, OK
90% PLAN
SUBMITTAL
 3/4/2024

AREA
 CUT FILL

VOLUME
 CUT FILL

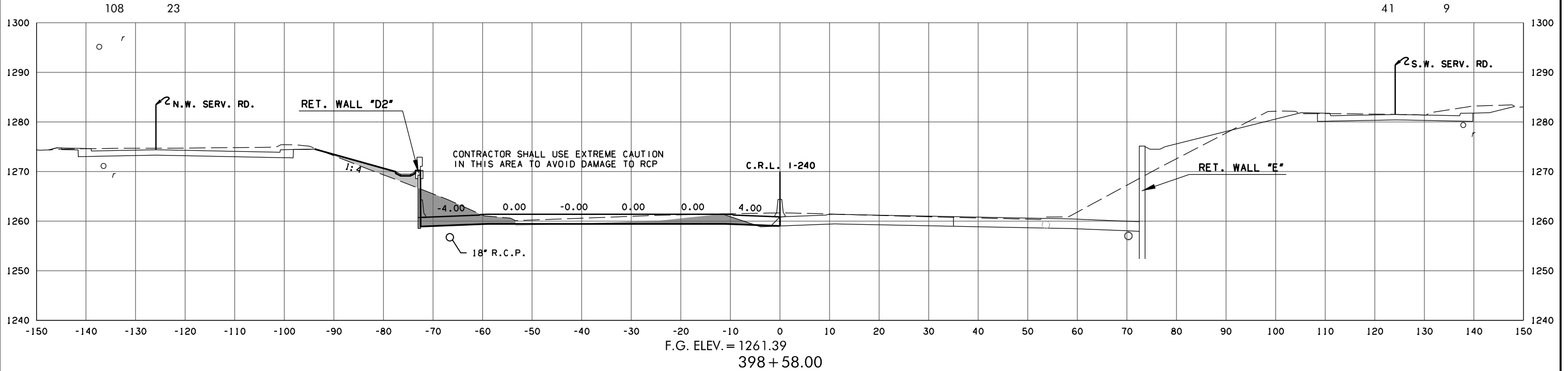

F.G. ELEV. = 1261.39
 398 + 58.00

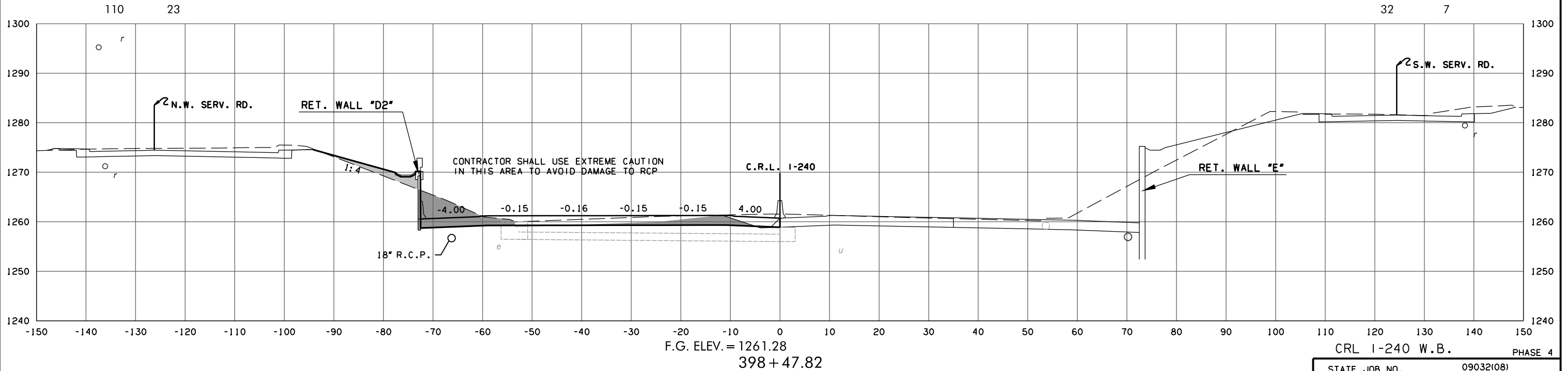

F.G. ELEV. = 1261.28
 398 + 47.82

CRL 1-240 W.B. PHASE 4

STATE JOB NO. 09032(08)
 OKLAHOMA COUNTY SHEET NO. X003

3/4/2024 3:54:02 PM
 H:\PROJECTS\2789_CrossRoads_Phase 4\Roadway\Drawings\Sections\0903208-XSEC.CRL. - 240.dgn

(CAUTION) THE LOCATION OF ALL UTILITIES AS SHOWN ARE APPROXIMATE. DUE TO RELOCATION'S PLANNED OR PRESENTLY UNDER CONSTRUCTION THERE ARE SOME UTILITIES THAT WILL BE RELOCATED AND NOT SHOWN ON THESE PLANS. THE CONTRACTOR SHALL BE RESPONSIBLE FOR ANY DAMAGE TO ALL UTILITIES.
 DEPTH & LOCATION OF EXISTING UTILITIES SHALL BE FIELD VERIFIED BY THE CONTRACTOR PRIOR TO CONSTRUCTION.

SEE DRAINAGE AREA MAP SHEETS FOR DRAINAGE SYMBOLOLOGY.

R/W & U/E PURCHASED UNDER JP 09032(05)

POB & ASSOCIATES, OKLAHOMA CITY, OK.
90% PLAN SUBMITTAL
 3/4/2024

AREA
 CUT FILL

VOLUME
 CUT FILL

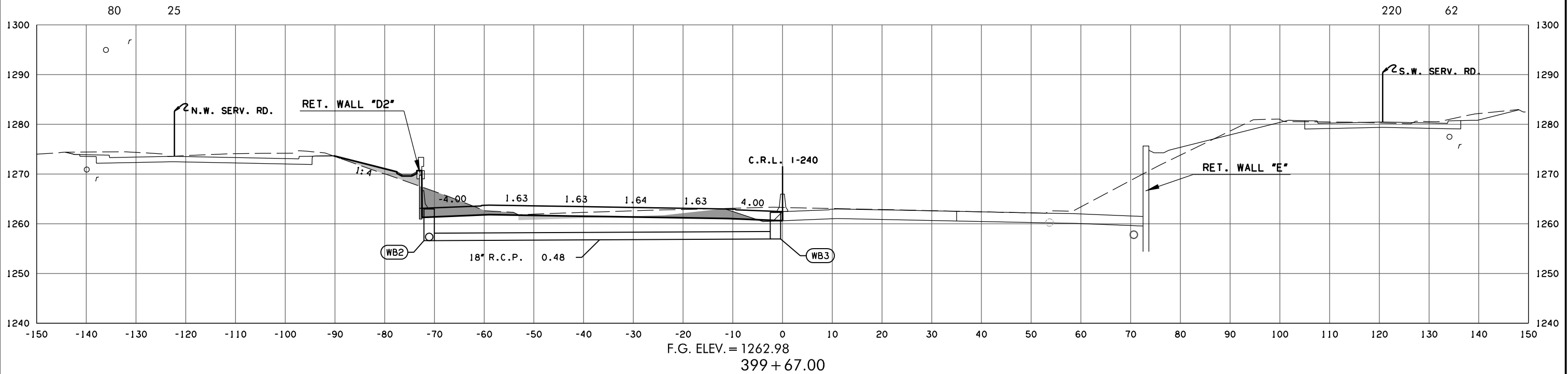

F.G. ELEV. = 1262.98
 399+67.00

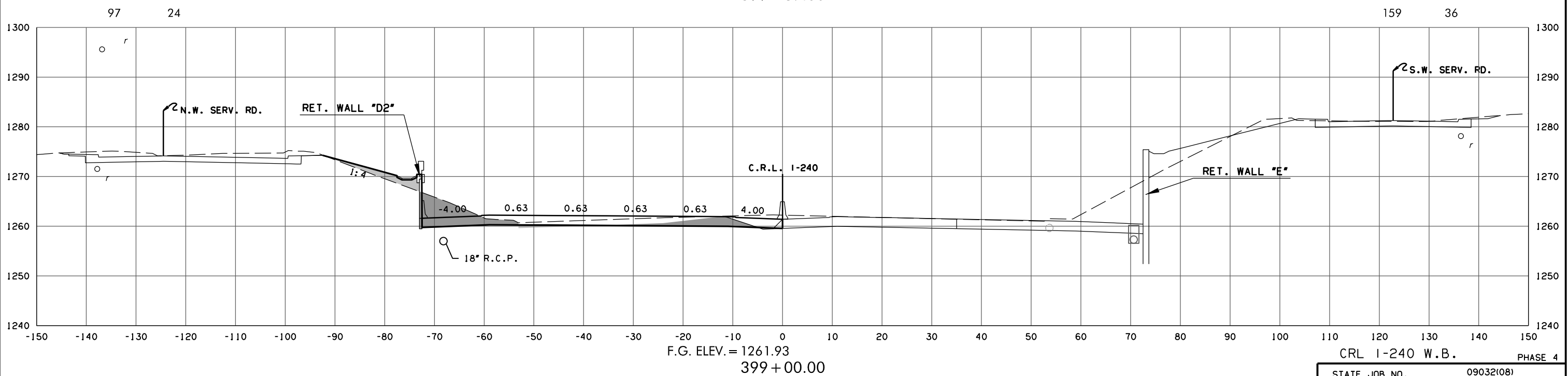

F.G. ELEV. = 1261.93
 399+00.00

CRL 1-240 W.B. PHASE 4
 STATE JOB NO. 09032(08)
 OKLAHOMA COUNTY SHEET NO. X004

3/4/2024 3:54:03 PM H:\PROJECTS\2789_CrossRoads_Phase 4\Roadway\Drawings\Sections\0903208-XSEC.CRL - 240.dgn

(CAUTION) THE LOCATION OF ALL UTILITIES AS SHOWN ARE APPROXIMATE. DUE TO RELOCATION'S PLANNED OR PRESENTLY UNDER CONSTRUCTION THERE ARE SOME UTILITIES THAT WILL BE RELOCATED AND NOT SHOWN ON THESE PLANS. THE CONTRACTOR SHALL BE RESPONSIBLE FOR ANY DAMAGE TO ALL UTILITIES.
 DEPTH & LOCATION OF EXISTING UTILITIES SHALL BE FIELD VERIFIED BY THE CONTRACTOR PRIOR TO CONSTRUCTION.

SEE DRAINAGE AREA MAP SHEETS FOR DRAINAGE SYMBOLOLOGY.

R/W & U/E PURCHASED UNDER JP 09032(05)

POB & ASSOCIATES, OKLAHOMA CITY, OK.
90% PLAN
SUBMITTAL
 3/4/2024

AREA
 CUT FILL

VOLUME
 CUT FILL

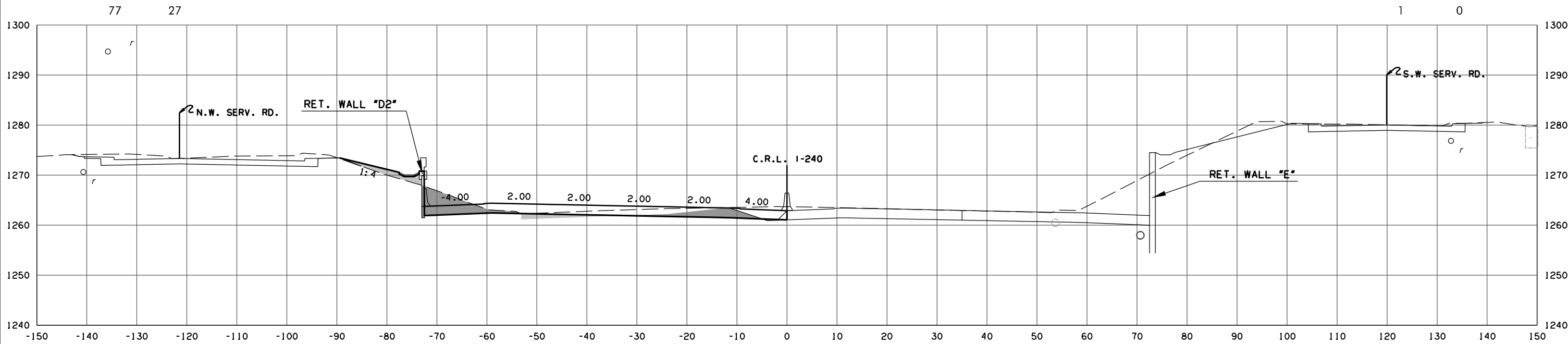

F.G. ELEV. = 1263.42
 399+91.33
 REVERSE CRO N

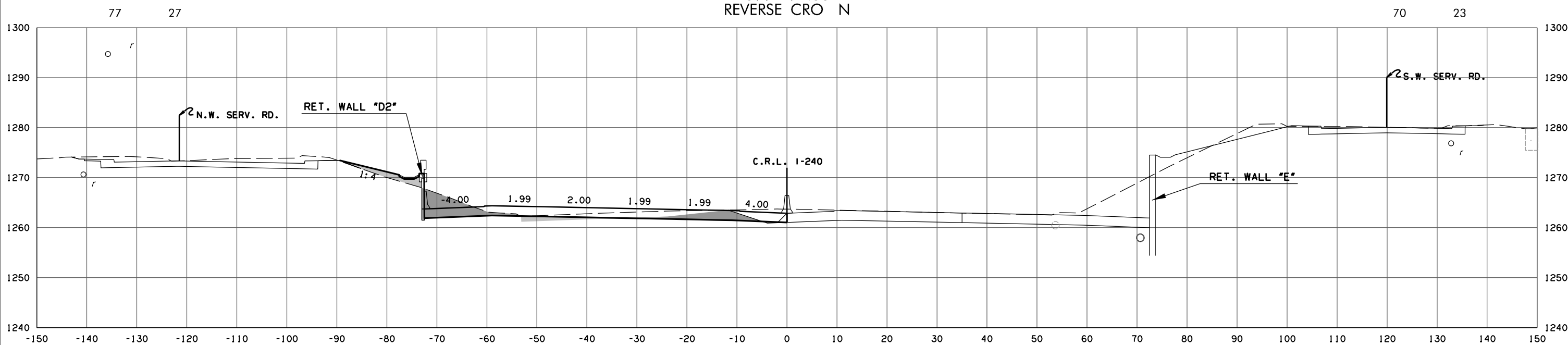

F.G. ELEV. = 1263.42
 399+90.94

CRL 1-240 W.B. PHASE 4
 STATE JOB NO. 09032(08)
 OKLAHOMA COUNTY SHEET NO. X005

3/4/2024 3:54:05 PM
 H:\PROJECTS\2789_CrossRoads_Phase 4\Roadway\Drawings\Sections\0903208-XSEC.CRL. - 240.dgn

(CAUTION) THE LOCATION OF ALL UTILITIES AS SHOWN ARE APPROXIMATE. DUE TO RELOCATION'S PLANNED OR PRESENTLY UNDER CONSTRUCTION THERE ARE SOME UTILITIES THAT WILL BE RELOCATED AND NOT SHOWN ON THESE PLANS. THE CONTRACTOR SHALL BE RESPONSIBLE FOR ANY DAMAGE TO ALL UTILITIES. DEPTH & LOCATION OF EXISTING UTILITIES SHALL BE FIELD VERIFIED BY THE CONTRACTOR PRIOR TO CONSTRUCTION.

SEE DRAINAGE AREA MAP SHEETS FOR DRAINAGE SYMBOLOLOGY.

R/W & U/E PURCHASED UNDER JP 09032(05)

POB & ASSOCIATES, OKLAHOMA CITY, OK.
90% PLAN SUBMITTAL
 3/4/2024

AREA
 CUT FILL

VOLUME
 CUT FILL

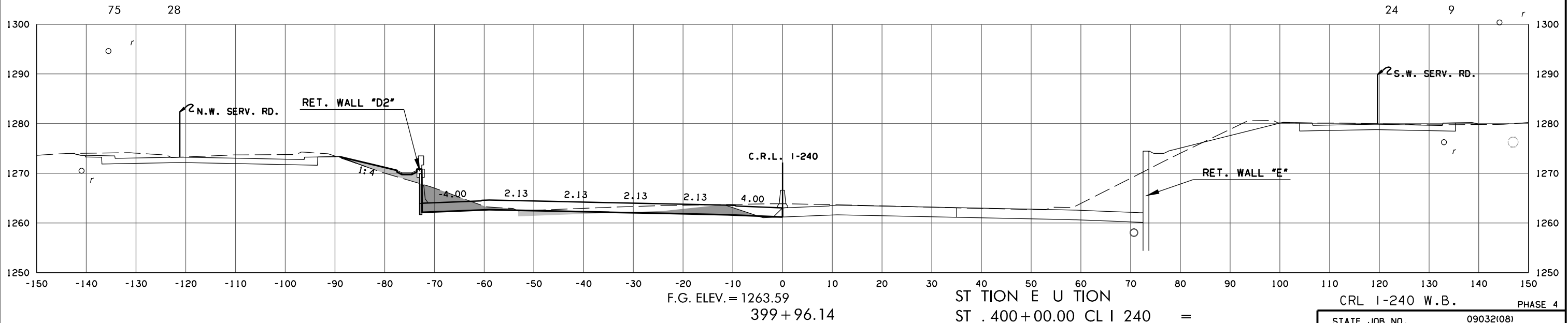
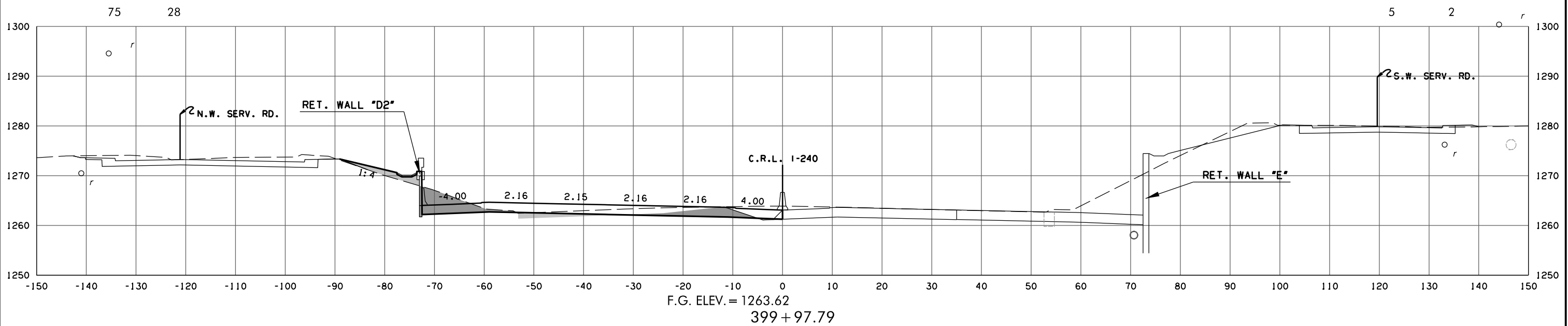

3/4/2024 3:54:07 PM H:\PROJECTS\2789_CrossRoads_Phase 4\Roadway\Drawings\Sections\0903208-XSEC.CRL - 240.dgn

STATION ELEVATION
 ST . 400+00.00 CL I 240 =
 ST . 399+96.14 C.R.L. I 240 D.

CRL 1-240 W.B. PHASE 4
 STATE JOB NO. 09032(08)
 OKLAHOMA COUNTY SHEET NO. X006

(CAUTION) THE LOCATION OF ALL UTILITIES AS SHOWN ARE APPROXIMATE. DUE TO RELOCATION'S PLANNED OR PRESENTLY UNDER CONSTRUCTION THERE ARE SOME UTILITIES THAT WILL BE RELOCATED AND NOT SHOWN ON THESE PLANS. THE CONTRACTOR SHALL BE RESPONSIBLE FOR ANY DAMAGE TO ALL UTILITIES.
 DEPTH & LOCATION OF EXISTING UTILITIES SHALL BE FIELD VERIFIED BY THE CONTRACTOR PRIOR TO CONSTRUCTION.

SEE DRAINAGE AREA MAP SHEETS FOR DRAINAGE SYMBOLOLOGY.

R/W & U/E PURCHASED UNDER JP 09032(05)

POB & ASSOCIATES, OKLAHOMA CITY, OK.
90% PLAN SUBMITTAL
 3/4/2024

AREA
 CUT FILL

VOLUME
 CUT FILL

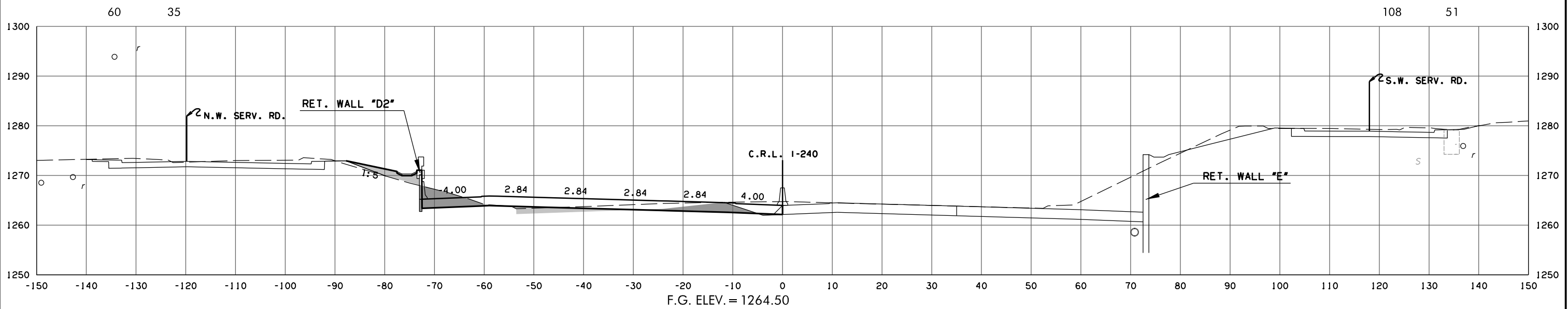

F.G. ELEV. = 1264.50
 400 + 43.47
 EGIN FULL SURROTATION

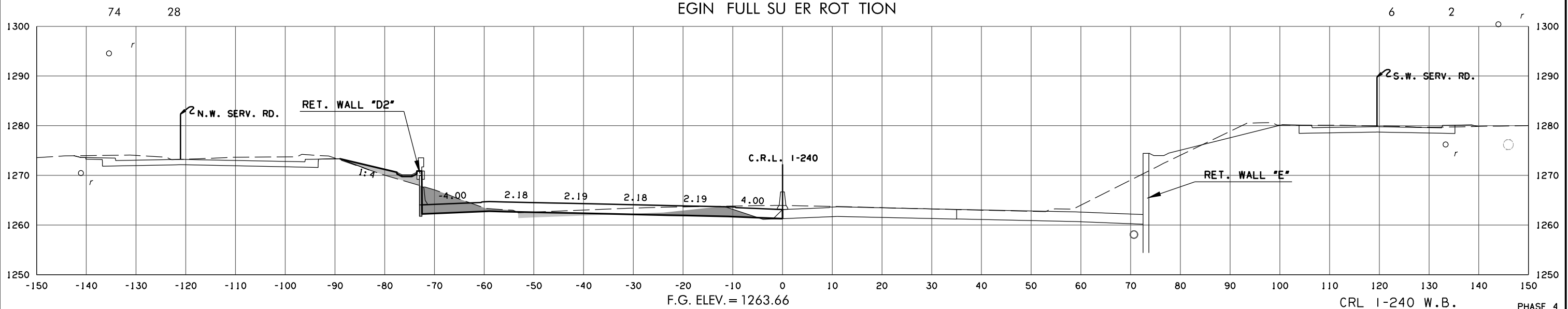

F.G. ELEV. = 1263.66
 400 + 00.00

CRL 1-240 W.B. PHASE 4
 STATE JOB NO. 09032(08)
 OKLAHOMA COUNTY SHEET NO. X007

3/4/2024 3:54:08 PM H:\PROJECTS\2789_CrossRoads_Phase 4\Roadway\Drawings\Sections\0903208-XSEC-CRL-1-240.dgn

(CAUTION) THE LOCATION OF ALL UTILITIES AS SHOWN ARE APPROXIMATE. DUE TO RELOCATION'S PLANNED OR PRESENTLY UNDER CONSTRUCTION THERE ARE SOME UTILITIES THAT WILL BE RELOCATED AND NOT SHOWN ON THESE PLANS. THE CONTRACTOR SHALL BE RESPONSIBLE FOR ANY DAMAGE TO ALL UTILITIES.
 DEPTH & LOCATION OF EXISTING UTILITIES SHALL BE FIELD VERIFIED BY THE CONTRACTOR PRIOR TO CONSTRUCTION.

SEE DRAINAGE AREA MAP SHEETS FOR DRAINAGE SYMBOLOLOGY.

R/W & U/E PURCHASED UNDER JP 09032(05)

POB & ASSOCIATES, OKLAHOMA CITY, OK.
90% PLAN SUBMITTAL
 3/4/2024

AREA
 CUT FILL

VOLUME
 CUT FILL

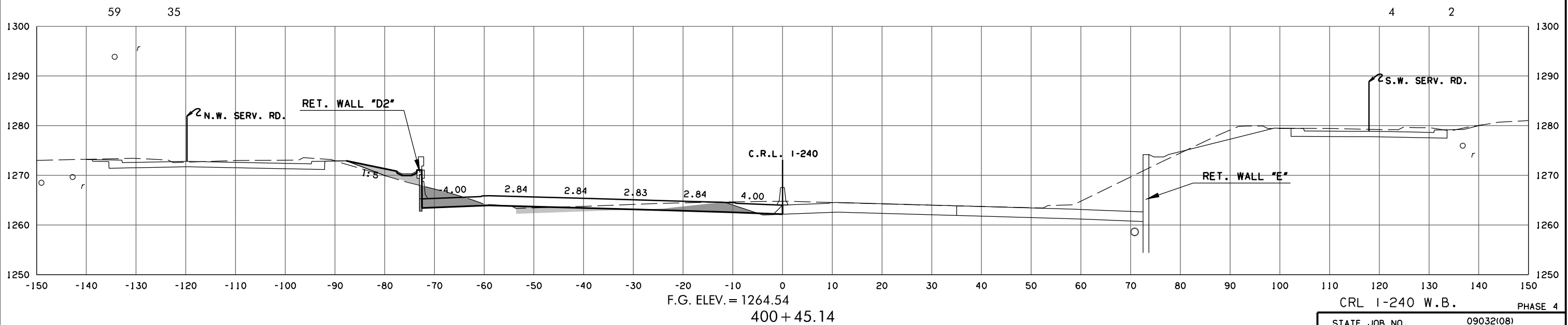
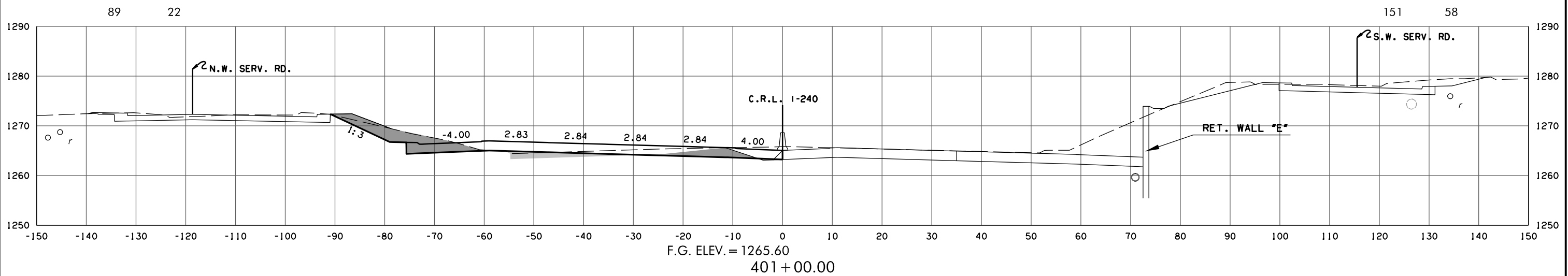
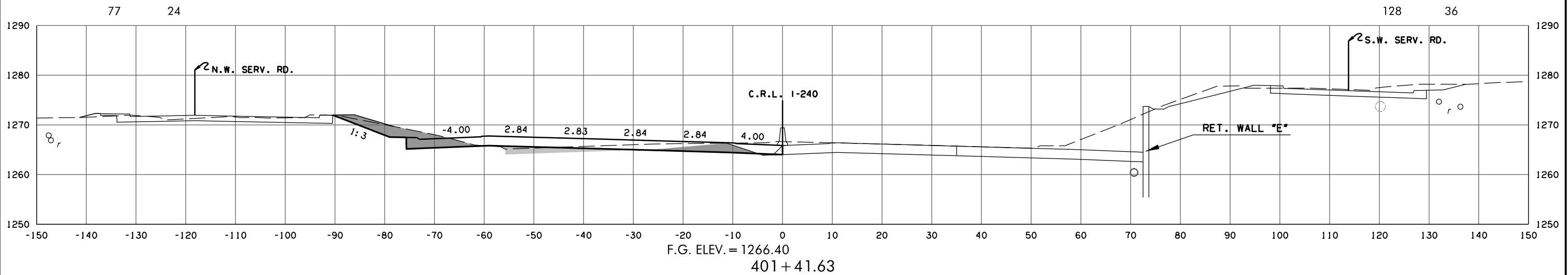

CRL 1-240 W.B. PHASE 4
 STATE JOB NO. 09032(08)
 OKLAHOMA COUNTY SHEET NO. X008

3/4/2024 3:54:40 PM
 H:\PROJECTS\2789_CrossRoads_Phase 4\Roadway\Drawings\Sections\0903208-XSEC.CRL - 240.dgn

(CAUTION) THE LOCATION OF ALL UTILITIES AS SHOWN ARE APPROXIMATE. DUE TO RELOCATION'S PLANNED OR PRESENTLY UNDER CONSTRUCTION THERE ARE SOME UTILITIES THAT WILL BE RELOCATED AND NOT SHOWN ON THESE PLANS. THE CONTRACTOR SHALL BE RESPONSIBLE FOR ANY DAMAGE TO ALL UTILITIES.
 DEPTH & LOCATION OF EXISTING UTILITIES SHALL BE FIELD VERIFIED BY THE CONTRACTOR PRIOR TO CONSTRUCTION.

SEE DRAINAGE AREA MAP SHEETS FOR DRAINAGE SYMBOLOLOGY.

R/W & U/E PURCHASED UNDER JP 09032(05)

POB & ASSOCIATES, OKLAHOMA CITY, OK.
90% PLAN SUBMITTAL
 3/4/2024

AREA
 CUT FILL

VOLUME
 CUT FILL

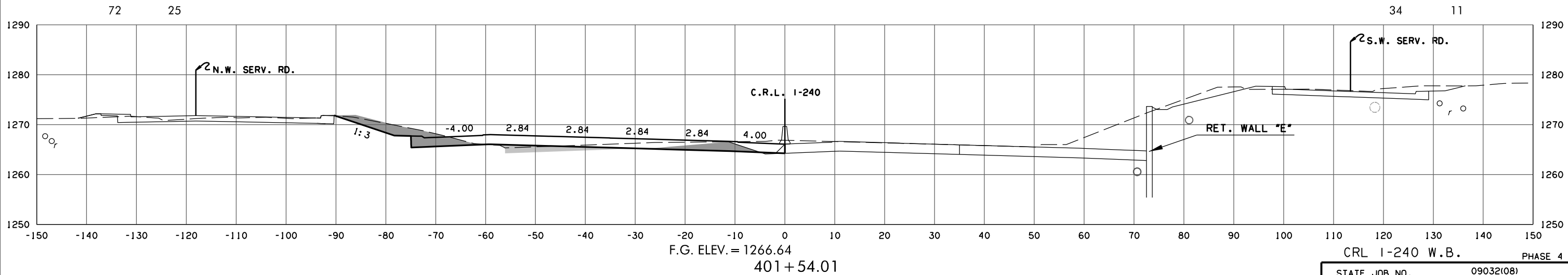
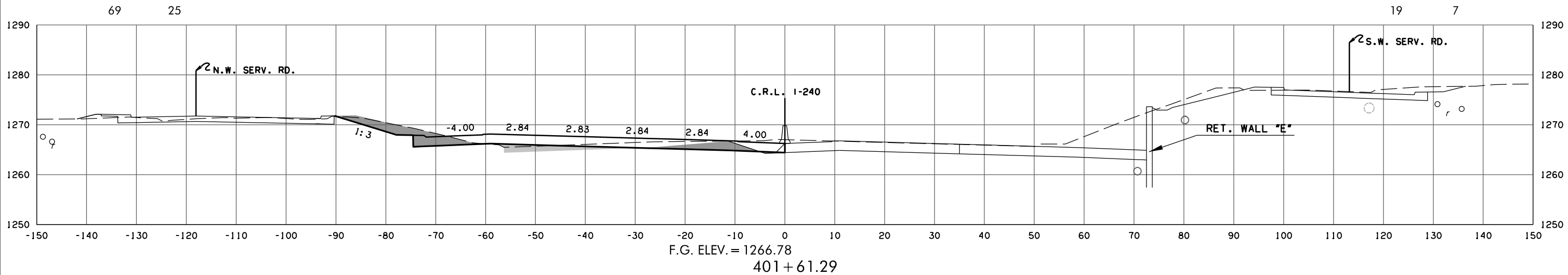
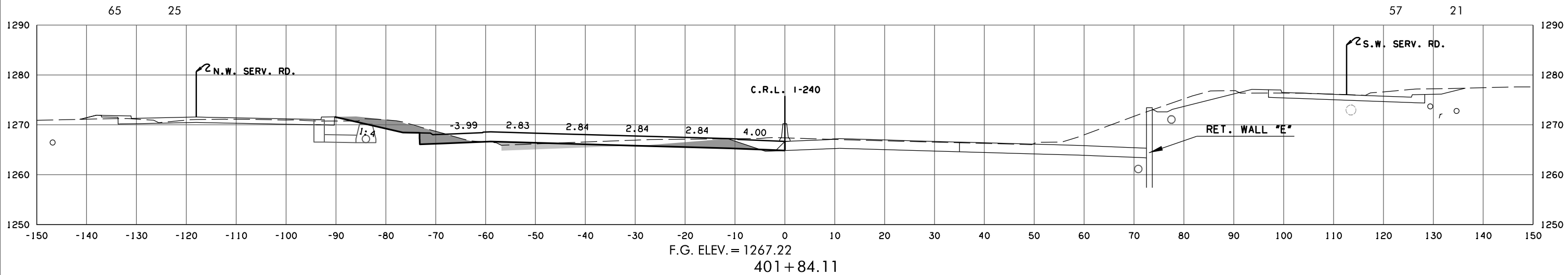

CRL 1-240 W.B. PHASE 4
 STATE JOB NO. 09032(08)
 OKLAHOMA COUNTY SHEET NO. X009

3/4/2024 3:54:42 PM
 H:\PROJECTS\2785_CrossRoads_Phase 4\Roadway\Drawings\Sections\0903208-XSEC.CRL - 240.dgn

(CAUTION) THE LOCATION OF ALL UTILITIES AS SHOWN ARE APPROXIMATE. DUE TO RELOCATION'S PLANNED OR PRESENTLY UNDER CONSTRUCTION THERE ARE SOME UTILITIES THAT WILL BE RELOCATED AND NOT SHOWN ON THESE PLANS. THE CONTRACTOR SHALL BE RESPONSIBLE FOR ANY DAMAGE TO ALL UTILITIES.
 DEPTH & LOCATION OF EXISTING UTILITIES SHALL BE FIELD VERIFIED BY THE CONTRACTOR PRIOR TO CONSTRUCTION.

SEE DRAINAGE AREA MAP SHEETS FOR DRAINAGE SYMBOLOLOGY.

R/W & U/E PURCHASED UNDER JP 09032(05)

POB & ASSOCIATES, OKLAHOMA CITY, OK.
90% PLAN SUBMITTAL
 3/4/2024

AREA
 CUT FILL

VOLUME
 CUT FILL

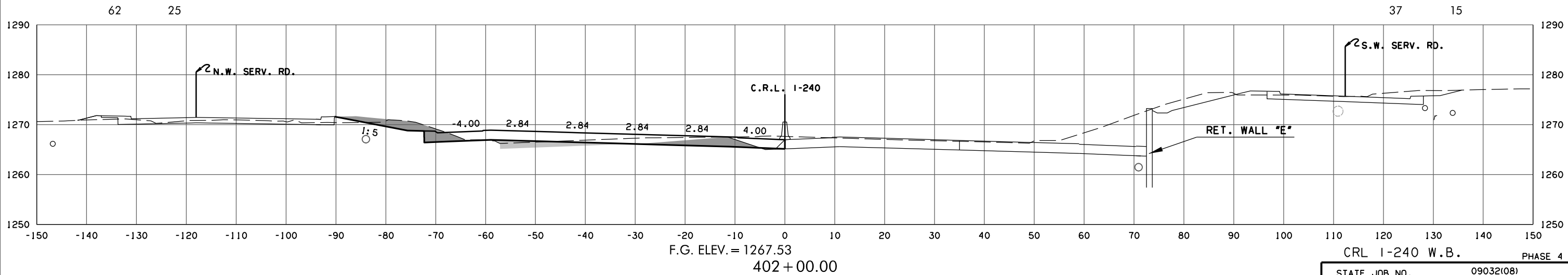
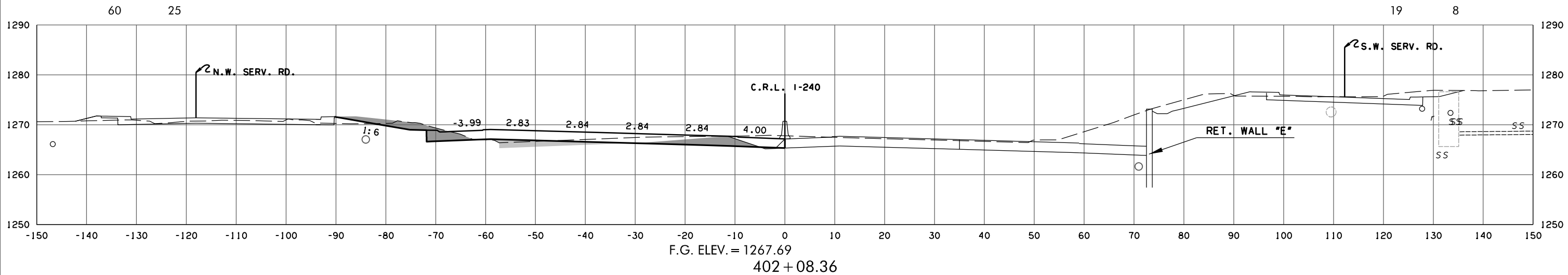
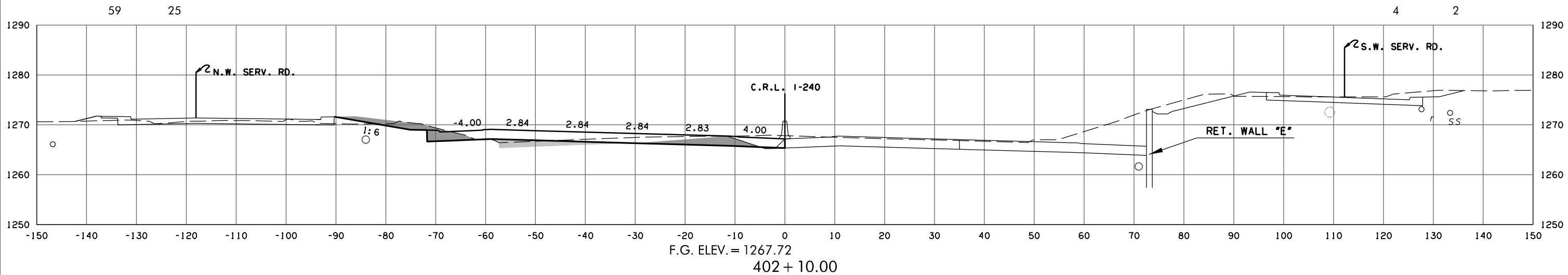

CRL 1-240 W.B. PHASE 4
 STATE JOB NO. 09032(08)
 OKLAHOMA COUNTY SHEET NO. X010

3/4/2024 3:54:14 PM H:\PROJECTS\2785_CrossRoads_Phase 4\Roadway\Drawings\Sections\0903208-XSEC.CRL - 240.dgn

(CAUTION) THE LOCATION OF ALL UTILITIES AS SHOWN ARE APPROXIMATE. DUE TO RELOCATION'S PLANNED OR PRESENTLY UNDER CONSTRUCTION THERE ARE SOME UTILITIES THAT WILL BE RELOCATED AND NOT SHOWN ON THESE PLANS. THE CONTRACTOR SHALL BE RESPONSIBLE FOR ANY DAMAGE TO ALL UTILITIES.
 DEPTH & LOCATION OF EXISTING UTILITIES SHALL BE FIELD VERIFIED BY THE CONTRACTOR PRIOR TO CONSTRUCTION.

SEE DRAINAGE AREA MAP SHEETS FOR DRAINAGE SYMBOLOLOGY.

R/W & U/E PURCHASED UNDER JP 09032(05)

POB & ASSOCIATES, OKLAHOMA CITY, OK.

90% PLAN SUBMITTAL

3/4/2024

AREA
 CUT FILL

VOLUME
 CUT FILL

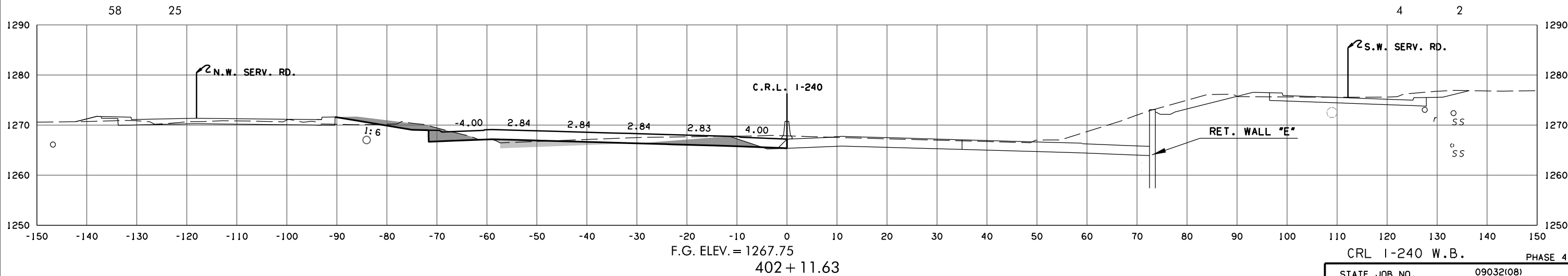
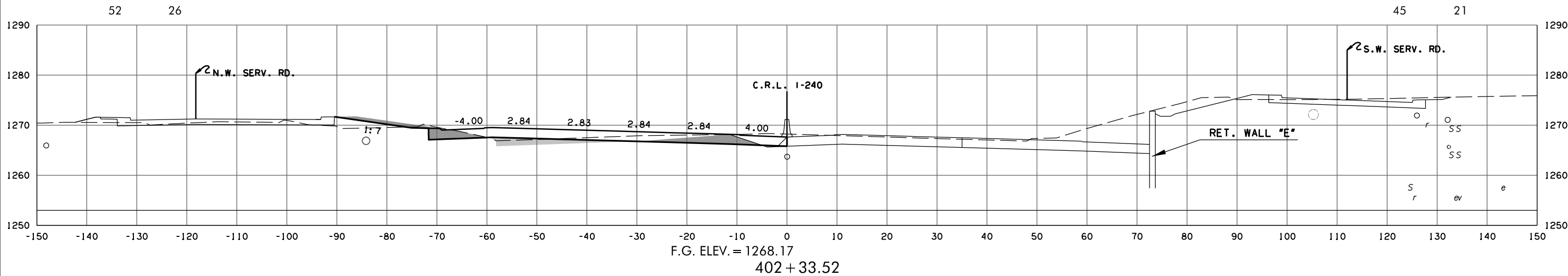
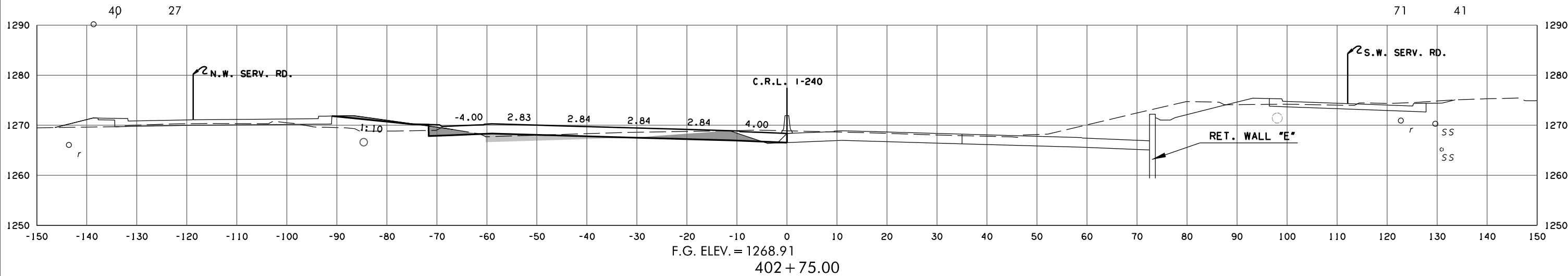

3/4/2024 3:54:45 PM H:\PROJECTS\2785_CrossRoads_Phase 4\Roadway\Drawings\Sections\0903208-XSEC.CRL - 240.dgn

(CAUTION) THE LOCATION OF ALL UTILITIES AS SHOWN ARE APPROXIMATE. DUE TO RELOCATION'S PLANNED OR PRESENTLY UNDER CONSTRUCTION THERE ARE SOME UTILITIES THAT WILL BE RELOCATED AND NOT SHOWN ON THESE PLANS. THE CONTRACTOR SHALL BE RESPONSIBLE FOR ANY DAMAGE TO ALL UTILITIES.
 DEPTH & LOCATION OF EXISTING UTILITIES SHALL BE FIELD VERIFIED BY THE CONTRACTOR PRIOR TO CONSTRUCTION.

SEE DRAINAGE AREA MAP SHEETS FOR DRAINAGE SYMBOLOLOGY.

R/W & U/E PURCHASED UNDER JP 09032(05)

POB & ASSOCIATES, OKLAHOMA CITY, OK.
90% PLAN SUBMITTAL
 3/4/2024

AREA
 CUT FILL

VOLUME
 CUT FILL

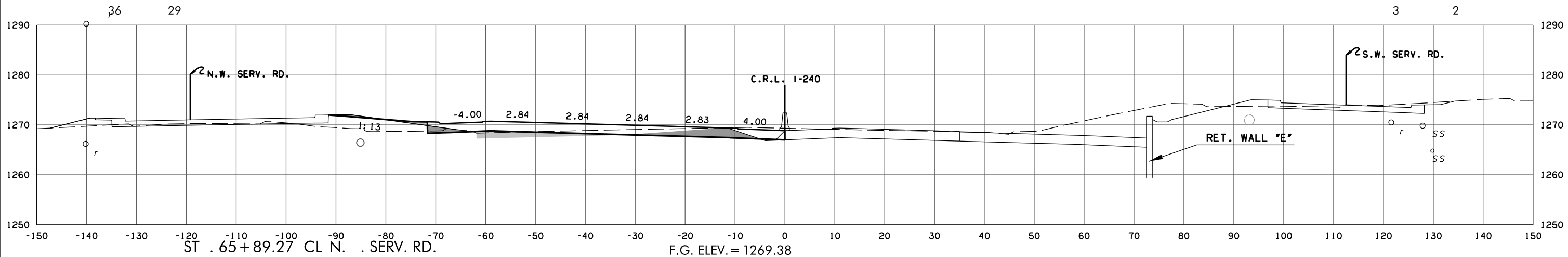

END CONSTRUCTION N. SERV. RD. CUR GUTTER = 403+02.21

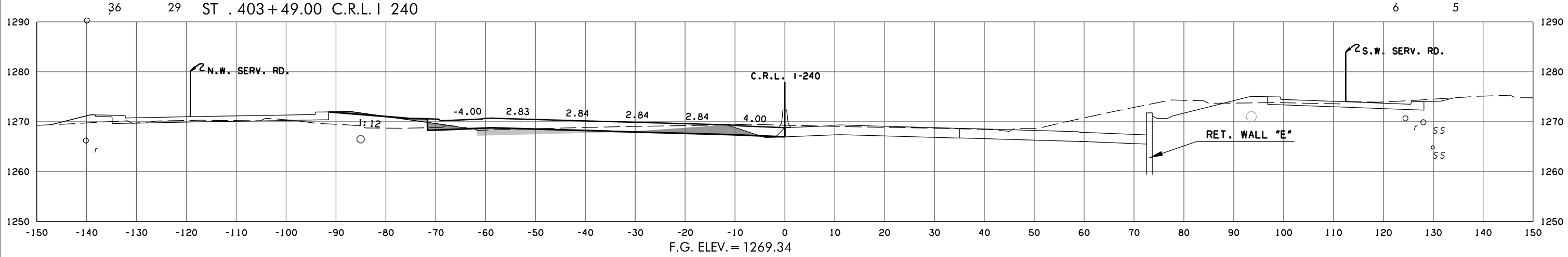

F.G. ELEV. = 1269.34
 403+00.00

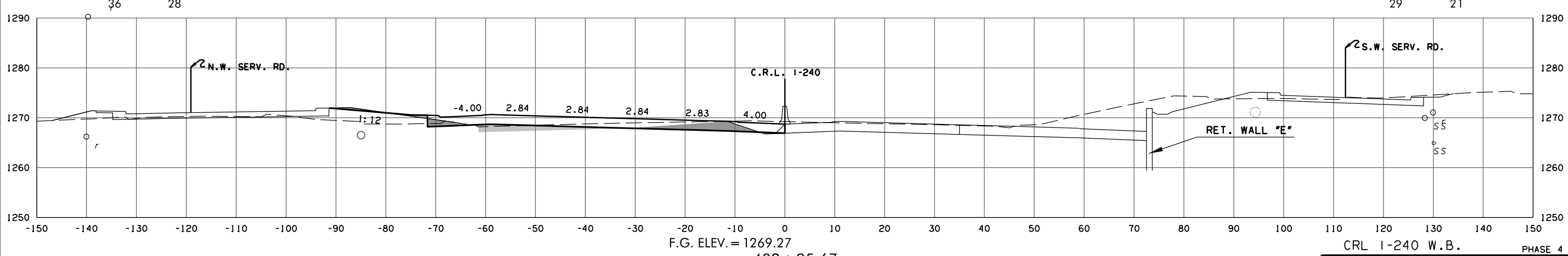

F.G. ELEV. = 1269.27
 402+95.67

CRL I-240 W.B. PHASE 4
 STATE JOB NO. 09032(08)
 OKLAHOMA COUNTY SHEET NO. X012

3/4/2024 3:54:17 PM H:\PROJECTS\2789_CrossRoads_Phase 4\Roadway\Drawings\Sections\0903208-XSEC.CRL. - 240.dgn

(CAUTION) THE LOCATION OF ALL UTILITIES AS SHOWN ARE APPROXIMATE. DUE TO RELOCATION'S PLANNED OR PRESENTLY UNDER CONSTRUCTION THERE ARE SOME UTILITIES THAT WILL BE RELOCATED AND NOT SHOWN ON THESE PLANS. THE CONTRACTOR SHALL BE RESPONSIBLE FOR ANY DAMAGE TO ALL UTILITIES.
 DEPTH & LOCATION OF EXISTING UTILITIES SHALL BE FIELD VERIFIED BY THE CONTRACTOR PRIOR TO CONSTRUCTION.

SEE DRAINAGE AREA MAP SHEETS FOR DRAINAGE SYMBOLOLOGY.

R/W & U/E PURCHASED UNDER JP 09032(05)

POB & ASSOCIATES, OKLAHOMA CITY, OK.
90% PLAN SUBMITTAL
 3/4/2024

AREA
 CUT FILL

VOLUME
 CUT FILL

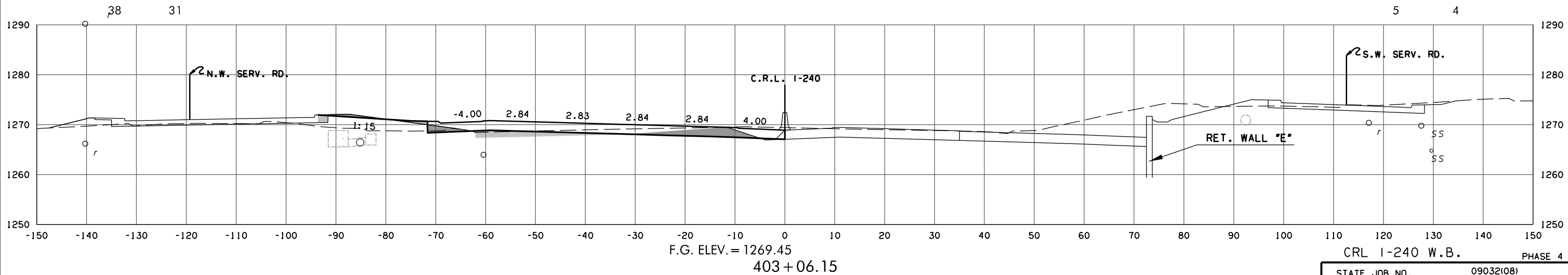
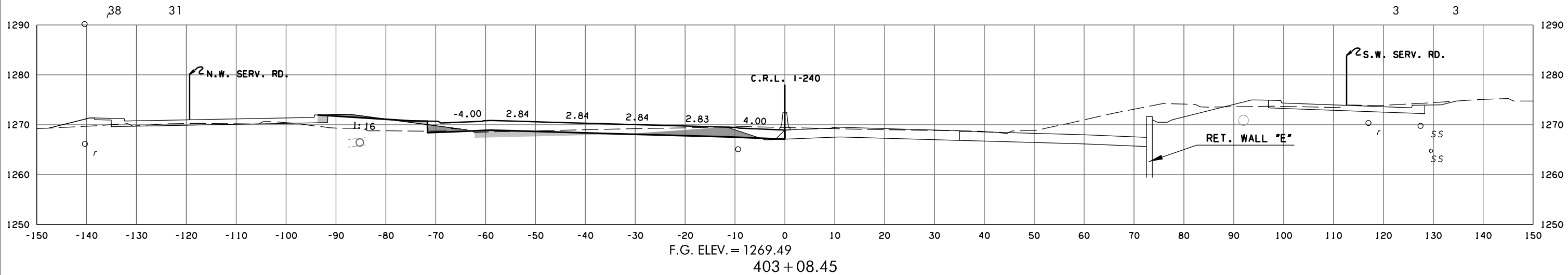
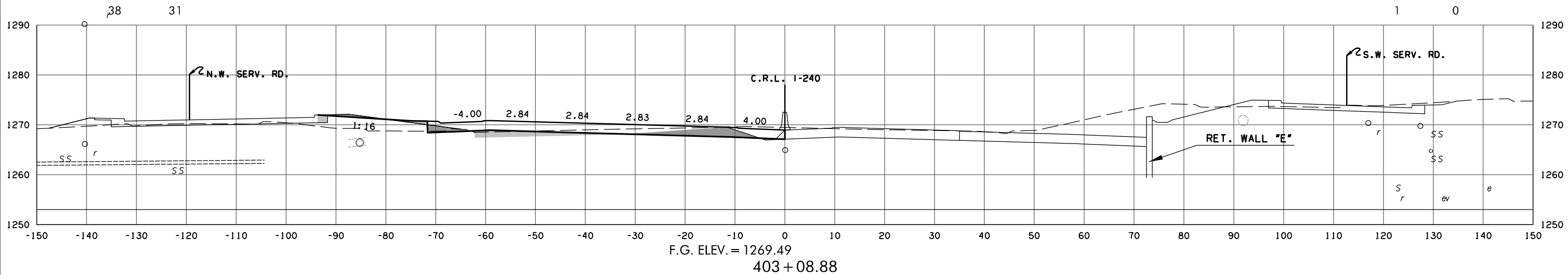

CRL 1-240 W.B. PHASE 4
 STATE JOB NO. 09032(08)
 OKLAHOMA COUNTY SHEET NO. X013

3/4/2024 3:54:19 PM
 H:\PROJECTS\2789_CrossRoads_Phase 4\Roadway\Drawings\Sections\0903208-XSEC.CRL. - 240.dgn

(CAUTION) THE LOCATION OF ALL UTILITIES AS SHOWN ARE APPROXIMATE. DUE TO RELOCATION'S PLANNED OR PRESENTLY UNDER CONSTRUCTION THERE ARE SOME UTILITIES THAT WILL BE RELOCATED AND NOT SHOWN ON THESE PLANS. THE CONTRACTOR SHALL BE RESPONSIBLE FOR ANY DAMAGE TO ALL UTILITIES.
 DEPTH & LOCATION OF EXISTING UTILITIES SHALL BE FIELD VERIFIED BY THE CONTRACTOR PRIOR TO CONSTRUCTION.

SEE DRAINAGE AREA MAP SHEETS FOR DRAINAGE SYMBOLOLOGY.

R/W & U/E PURCHASED UNDER JP 09032(05)

POB & ASSOCIATES, OKLAHOMA CITY, OK.
90% PLAN SUBMITTAL
 3/4/2024

AREA
 CUT FILL

VOLUME
 CUT FILL

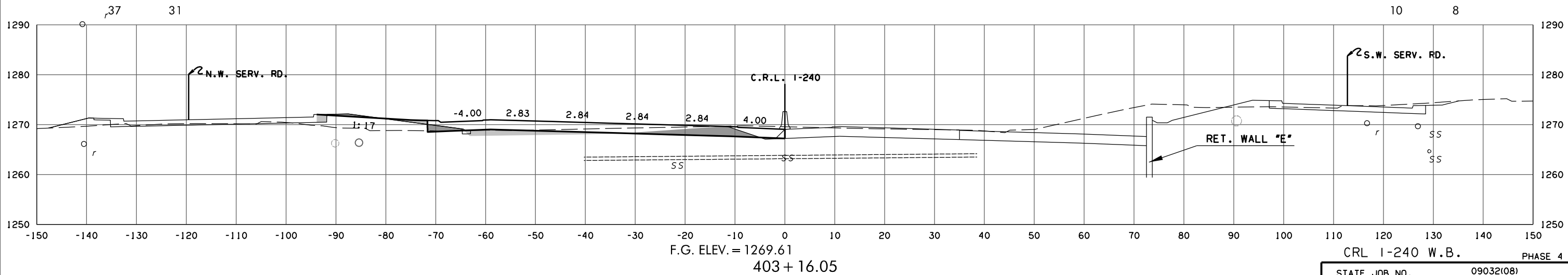
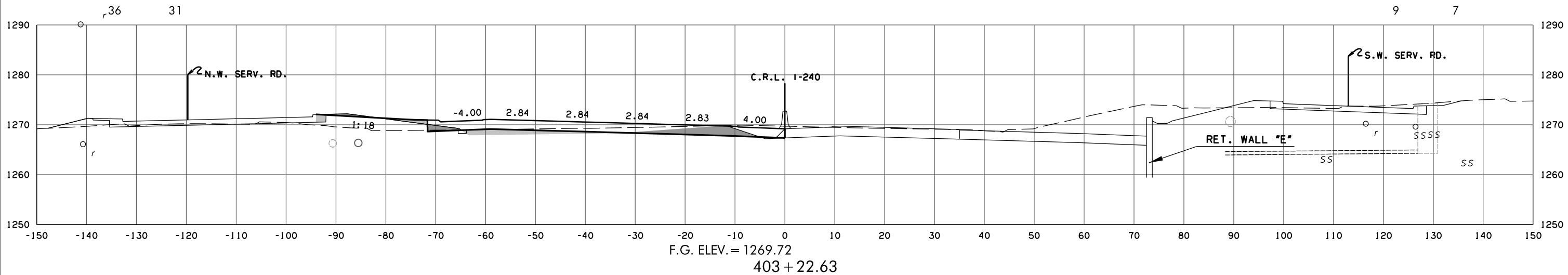
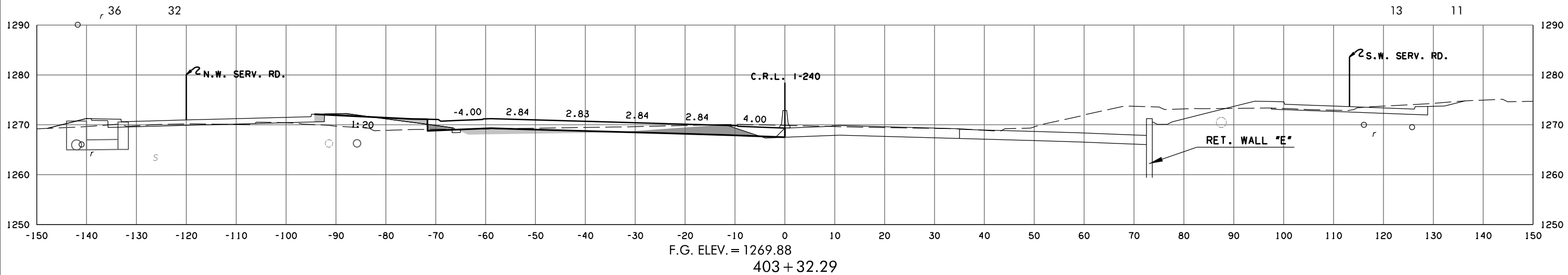

CRL 1-240 W.B. PHASE 4
 STATE JOB NO. 09032(08)
 OKLAHOMA COUNTY SHEET NO. X014

3/4/2024 3:54:20 PM H:\PROJECTS\2789_CrossRoads_Phase 4\Roadway\Drawings\Sections\0903208-XSEC.CRL - 240.dgn

(CAUTION) THE LOCATION OF ALL UTILITIES AS SHOWN ARE APPROXIMATE. DUE TO RELOCATION'S PLANNED OR PRESENTLY UNDER CONSTRUCTION THERE ARE SOME UTILITIES THAT WILL BE RELOCATED AND NOT SHOWN ON THESE PLANS. THE CONTRACTOR SHALL BE RESPONSIBLE FOR ANY DAMAGE TO ALL UTILITIES.
 DEPTH & LOCATION OF EXISTING UTILITIES SHALL BE FIELD VERIFIED BY THE CONTRACTOR PRIOR TO CONSTRUCTION.

SEE DRAINAGE AREA MAP SHEETS FOR DRAINAGE SYMBOLOLOGY.

R/W & U/E PURCHASED UNDER JP 09032(05)

POB & ASSOCIATES, OKLAHOMA CITY, OK.
90% PLAN SUBMITTAL
 3/4/2024

AREA
 CUT FILL

VOLUME
 CUT FILL

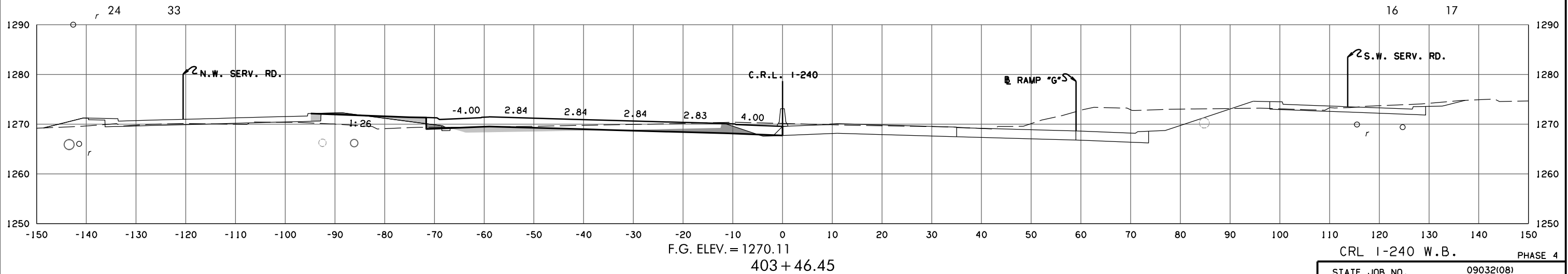
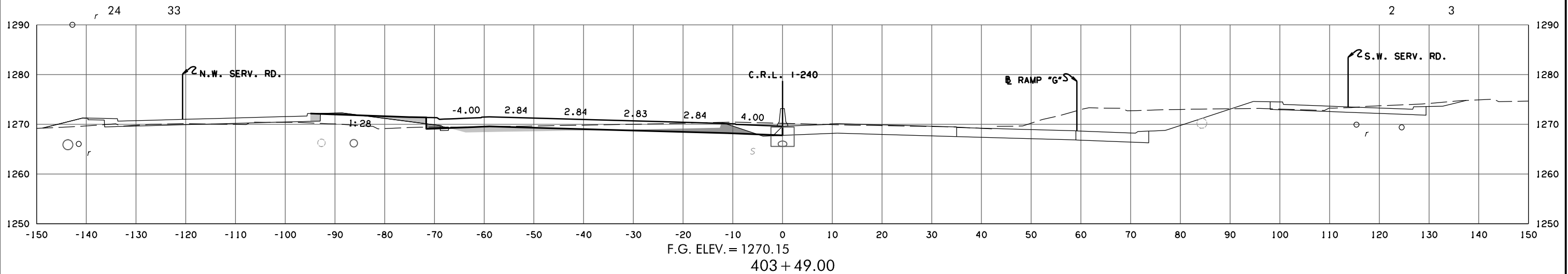
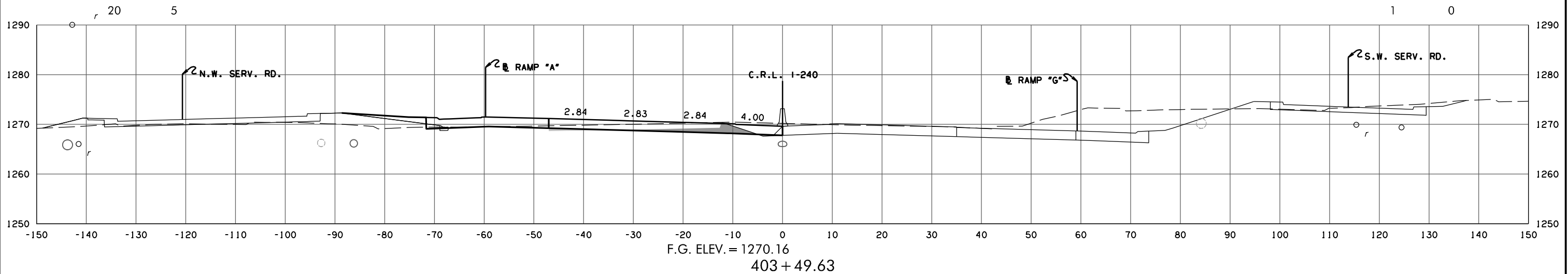

3/4/2024 3:54:22 PM H:\PROJECTS\2789_CrossRoads_Phase 4\Roadway\Drawings\Sections\0903208-XSEC.CRL. - 240.dgn

CRL 1-240 W.B. PHASE 4
 STATE JOB NO. 09032(08)
 OKLAHOMA COUNTY SHEET NO. X015

(CAUTION) THE LOCATION OF ALL UTILITIES AS SHOWN ARE APPROXIMATE. DUE TO RELOCATION'S PLANNED OR PRESENTLY UNDER CONSTRUCTION THERE ARE SOME UTILITIES THAT WILL BE RELOCATED AND NOT SHOWN ON THESE PLANS. THE CONTRACTOR SHALL BE RESPONSIBLE FOR ANY DAMAGE TO ALL UTILITIES.

DEPTH & LOCATION OF EXISTING UTILITIES SHALL BE FIELD VERIFIED BY THE CONTRACTOR PRIOR TO CONSTRUCTION.

SEE DRAINAGE AREA MAP SHEETS FOR DRAINAGE SYMBOLOLOGY.

R/W & U/E PURCHASED UNDER JP 09032(05)

POB & ASSOCIATES, OKLAHOMA CITY, OK.

**90% PLAN
SUBMITTAL**

3/4/2024

AREA
CUT FILL

VOLUME
CUT FILL

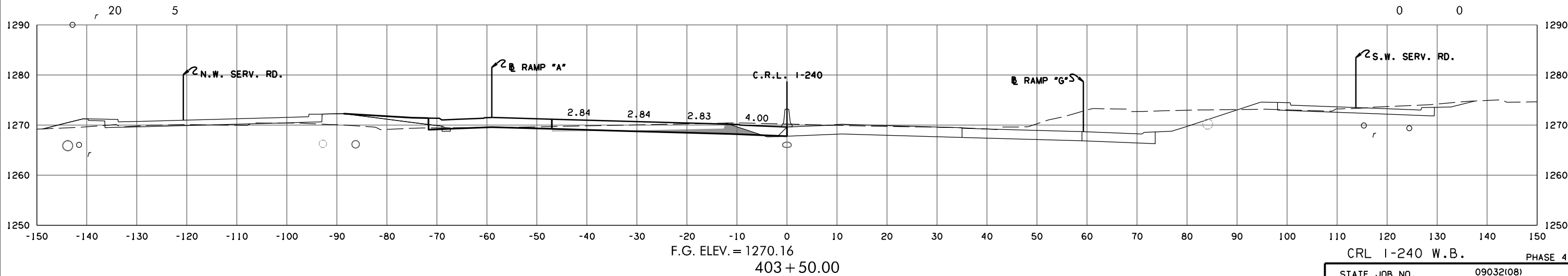
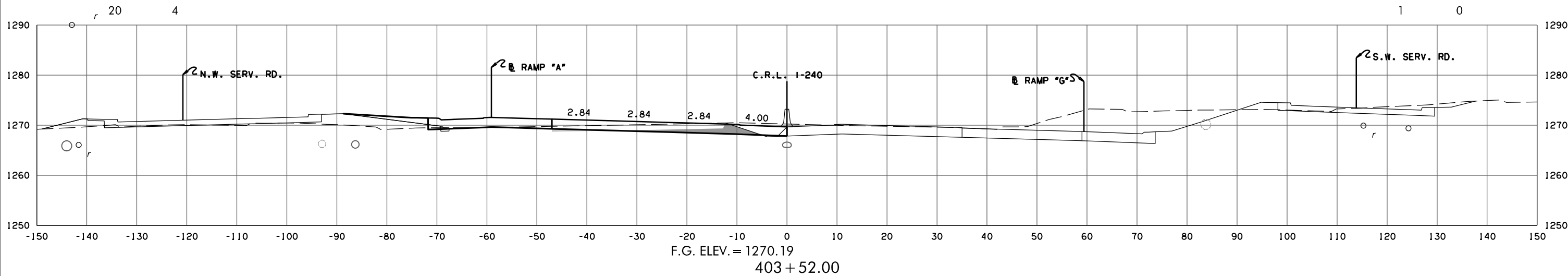
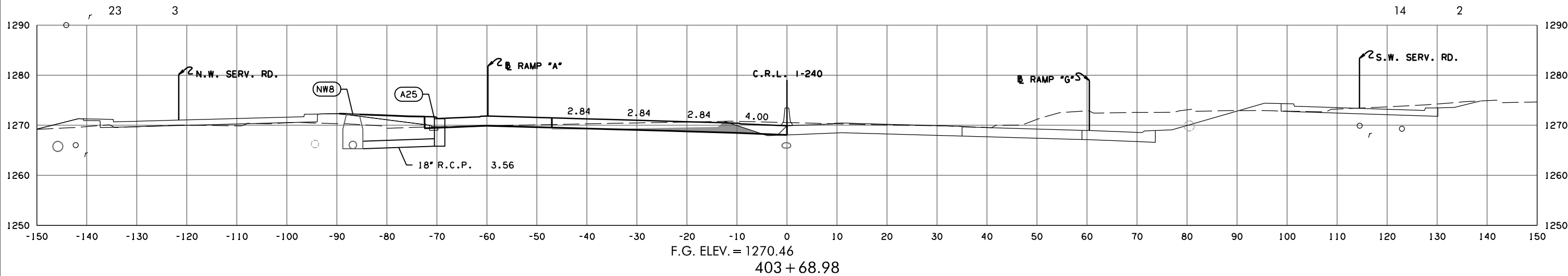

3/4/2024 3:54:24 PM H:\PROJECTS\2785_CrossRoads_Phase 4\Roadway\Drawings\Sections\0903208-XSEC.CRL - 240.dgn

CRL 1-240 W.B. PHASE 4
STATE JOB NO. 09032(08)
OKLAHOMA COUNTY SHEET NO. X016

(CAUTION) THE LOCATION OF ALL UTILITIES AS SHOWN ARE APPROXIMATE. DUE TO RELOCATION'S PLANNED OR PRESENTLY UNDER CONSTRUCTION THERE ARE SOME UTILITIES THAT WILL BE RELOCATED AND NOT SHOWN ON THESE PLANS. THE CONTRACTOR SHALL BE RESPONSIBLE FOR ANY DAMAGE TO ALL UTILITIES.

DEPTH & LOCATION OF EXISTING UTILITIES SHALL BE FIELD VERIFIED BY THE CONTRACTOR PRIOR TO CONSTRUCTION.

SEE DRAINAGE AREA MAP SHEETS FOR DRAINAGE SYMBOLOLOGY.

R/W & U/E PURCHASED UNDER JP 09032(05)

POB & ASSOCIATES, OKLAHOMA CITY, OK.

**90% PLAN
SUBMITTAL**

3/4/2024

AREA
CUT FILL

VOLUME
CUT FILL

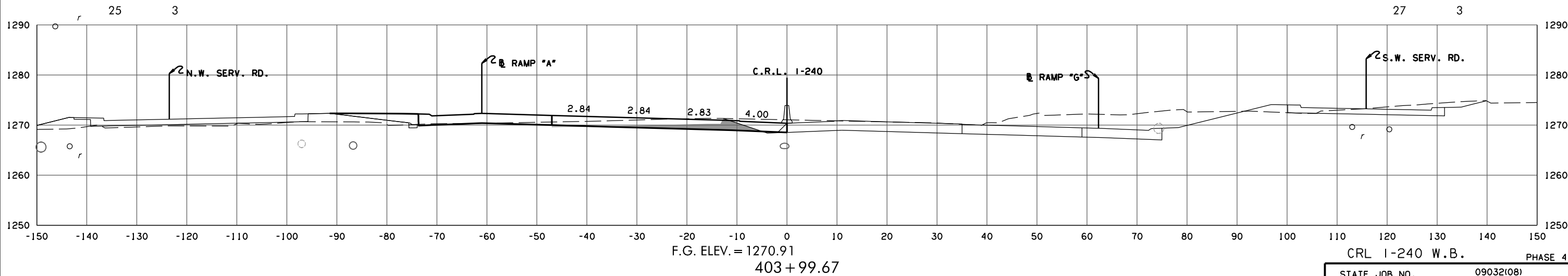
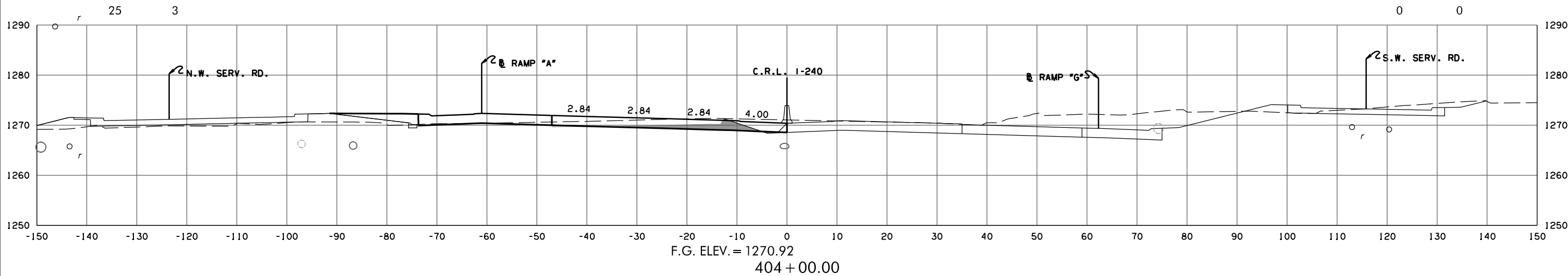
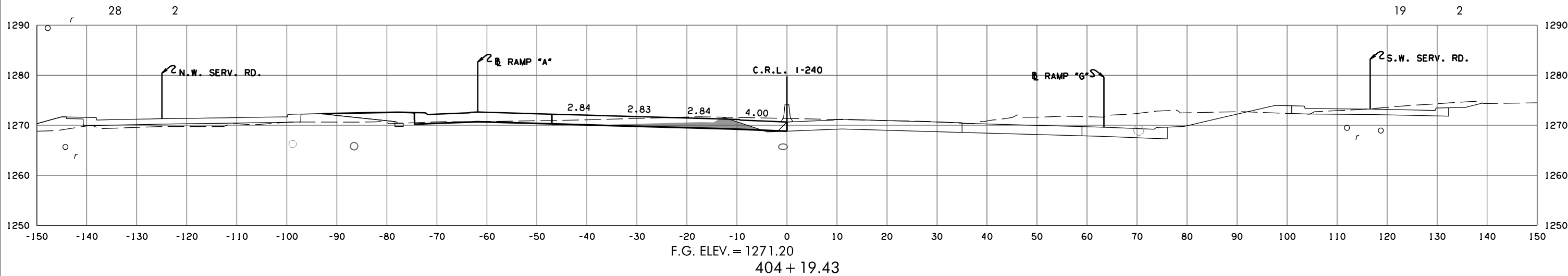

CRL 1-240 W.B. PHASE 4
STATE JOB NO. 09032(08)
OKLAHOMA COUNTY SHEET NO. X017

3/4/2024 3:54:26 PM H:\PROJECTS\2789_CrossRoads_Phase 4\Roadway\Drawings\Sections\0903208-XSEC.CRL - 240.dgn

(CAUTION) THE LOCATION OF ALL UTILITIES AS SHOWN ARE APPROXIMATE. DUE TO RELOCATION'S PLANNED OR PRESENTLY UNDER CONSTRUCTION THERE ARE SOME UTILITIES THAT WILL BE RELOCATED AND NOT SHOWN ON THESE PLANS. THE CONTRACTOR SHALL BE RESPONSIBLE FOR ANY DAMAGE TO ALL UTILITIES.
 DEPTH & LOCATION OF EXISTING UTILITIES SHALL BE FIELD VERIFIED BY THE CONTRACTOR PRIOR TO CONSTRUCTION.

SEE DRAINAGE AREA MAP SHEETS FOR DRAINAGE SYMBOLOLOGY.

R/W & U/E PURCHASED UNDER JP 09032(05)

POB & ASSOCIATES, OKLAHOMA CITY, OK.

90% PLAN SUBMITTAL

3/4/2024

AREA
 CUT FILL

VOLUME
 CUT FILL

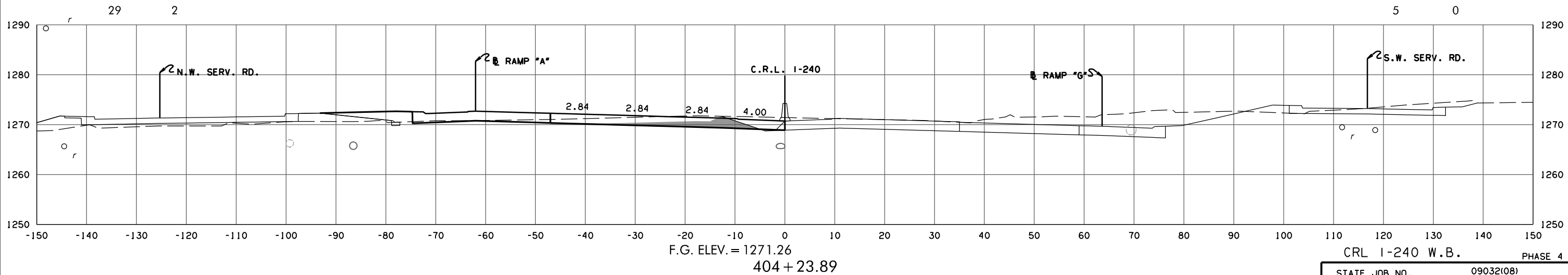
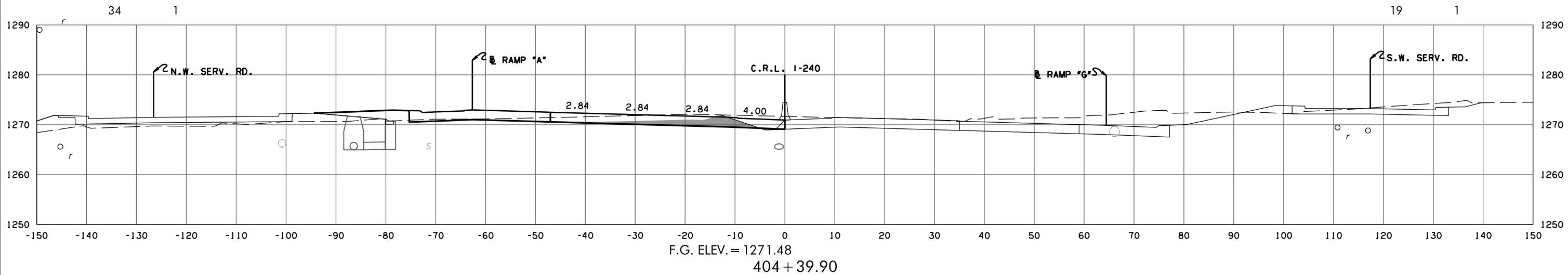
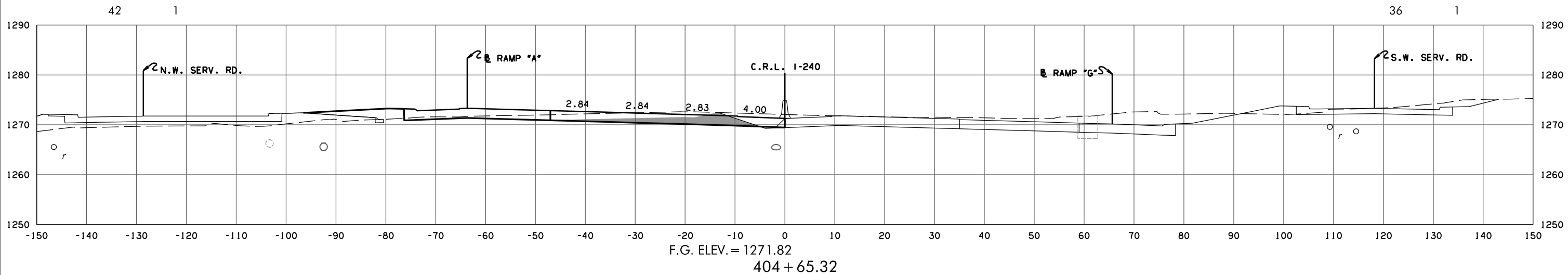

3/4/2024 3:54:27 PM H:\PROJECTS\2789_CrossRoads_Phase 4\Roadway\Drawings\Sections\0903208-XSEC.CRL. - 240.dgn

(CAUTION) THE LOCATION OF ALL UTILITIES AS SHOWN ARE APPROXIMATE. DUE TO RELOCATION'S PLANNED OR PRESENTLY UNDER CONSTRUCTION THERE ARE SOME UTILITIES THAT WILL BE RELOCATED AND NOT SHOWN ON THESE PLANS. THE CONTRACTOR SHALL BE RESPONSIBLE FOR ANY DAMAGE TO ALL UTILITIES.
 DEPTH & LOCATION OF EXISTING UTILITIES SHALL BE FIELD VERIFIED BY THE CONTRACTOR PRIOR TO CONSTRUCTION.

SEE DRAINAGE AREA MAP SHEETS FOR DRAINAGE SYMBOLOLOGY.

R/W & U/E PURCHASED UNDER JP 09032(05)

POB & ASSOCIATES, OKLAHOMA CITY, OK.

90% PLAN SUBMITTAL

3/4/2024

AREA
 CUT FILL

VOLUME
 CUT FILL

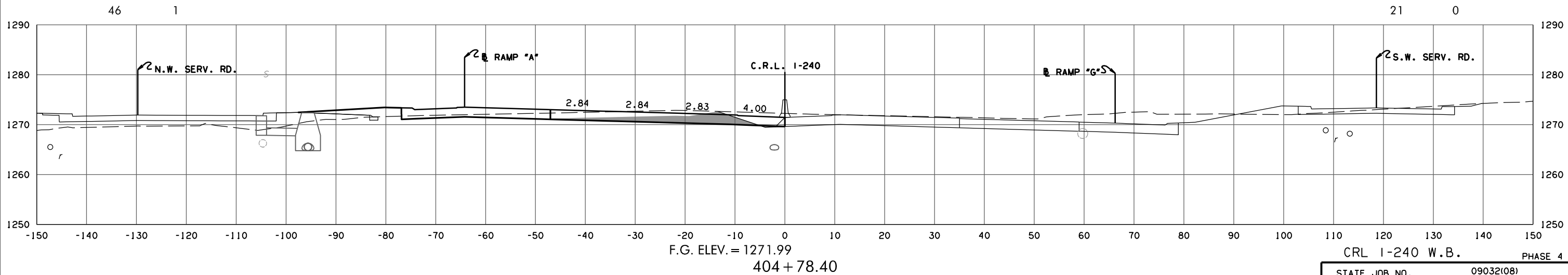
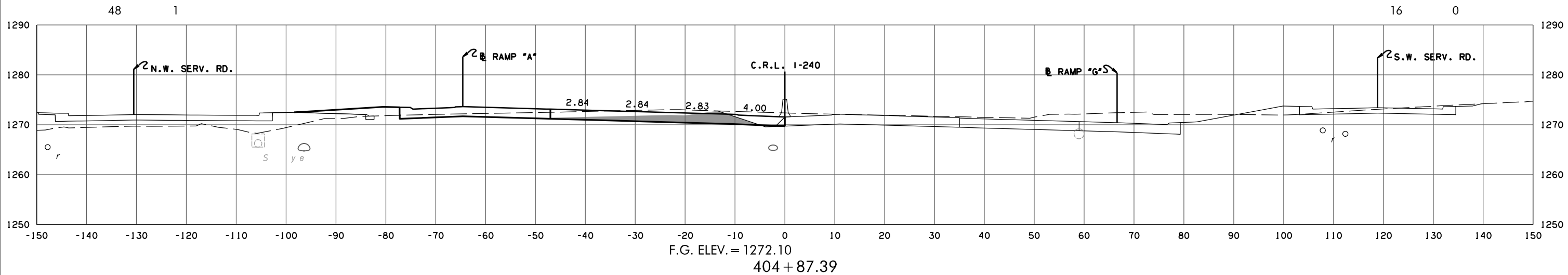
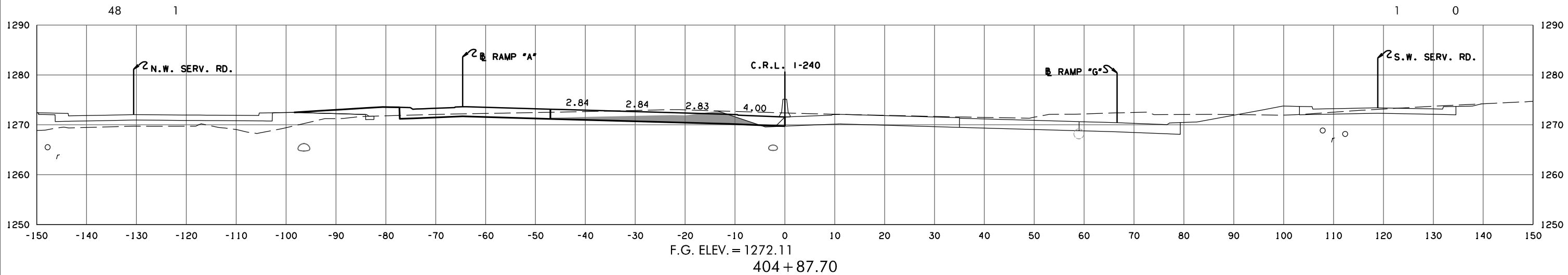

CRL 1-240 W.B. PHASE 4

STATE JOB NO. 09032(08)
 OKLAHOMA COUNTY SHEET NO. X019

3/4/2024 3:54:29 PM H:\PROJECTS\2789_CrossRoads_Phase 4\Roadway\Drawings\Sections\0903208-XSEC.CRL - 240.dgn

(CAUTION) THE LOCATION OF ALL UTILITIES AS SHOWN ARE APPROXIMATE. DUE TO RELOCATION'S PLANNED OR PRESENTLY UNDER CONSTRUCTION THERE ARE SOME UTILITIES THAT WILL BE RELOCATED AND NOT SHOWN ON THESE PLANS. THE CONTRACTOR SHALL BE RESPONSIBLE FOR ANY DAMAGE TO ALL UTILITIES.
 DEPTH & LOCATION OF EXISTING UTILITIES SHALL BE FIELD VERIFIED BY THE CONTRACTOR PRIOR TO CONSTRUCTION.

SEE DRAINAGE AREA MAP SHEETS FOR DRAINAGE SYMBOLOLOGY.

R/W & U/E PURCHASED UNDER JP 09032(05)

POB & ASSOCIATES, OKLAHOMA CITY, OK.

90% PLAN SUBMITTAL

3/4/2024

AREA
 CUT FILL

VOLUME
 CUT FILL

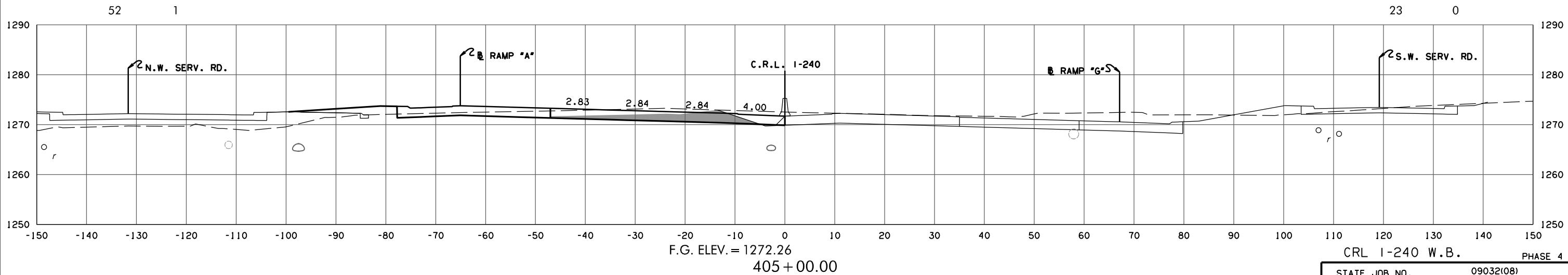
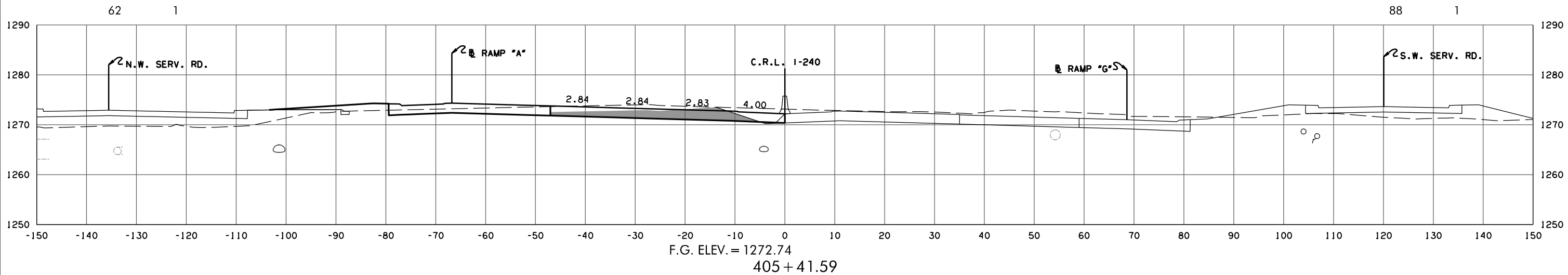
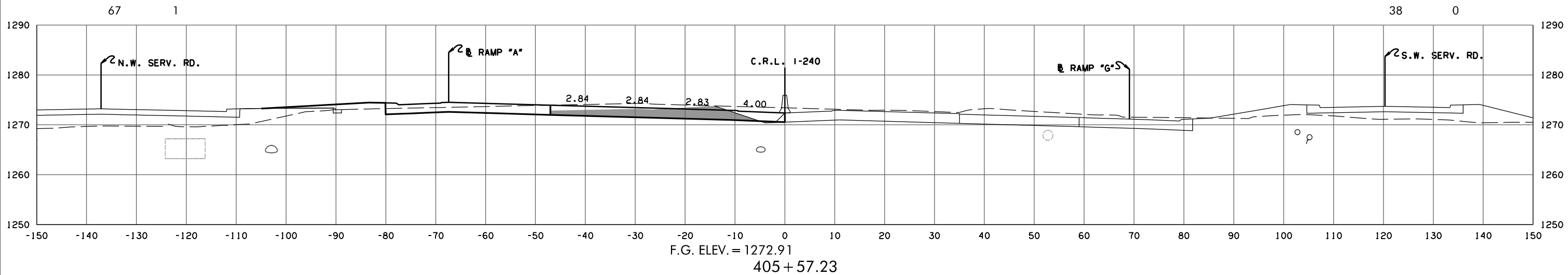

CRL 1-240 W.B. PHASE 4
 STATE JOB NO. 09032(08)
 OKLAHOMA COUNTY SHEET NO. X020

3/4/2024 3:54:31 PM H:\PROJECTS\2789_CrossRoads_Phase 4\Roadway\Drawings\Sections\0903208-XSEC.CRL - 240.dgn

(CAUTION) THE LOCATION OF ALL UTILITIES AS SHOWN ARE APPROXIMATE. DUE TO RELOCATION'S PLANNED OR PRESENTLY UNDER CONSTRUCTION THERE ARE SOME UTILITIES THAT WILL BE RELOCATED AND NOT SHOWN ON THESE PLANS. THE CONTRACTOR SHALL BE RESPONSIBLE FOR ANY DAMAGE TO ALL UTILITIES.

DEPTH & LOCATION OF EXISTING UTILITIES SHALL BE FIELD VERIFIED BY THE CONTRACTOR PRIOR TO CONSTRUCTION.

SEE DRAINAGE AREA MAP SHEETS FOR DRAINAGE SYMBOLOLOGY.

R/W & U/E PURCHASED UNDER JP 09032(05)

POB & ASSOCIATES, OKLAHOMA CITY, OK.

90% PLAN
SUBMITTAL

3/4/2024

AREA
CUT FILL

VOLUME
CUT FILL

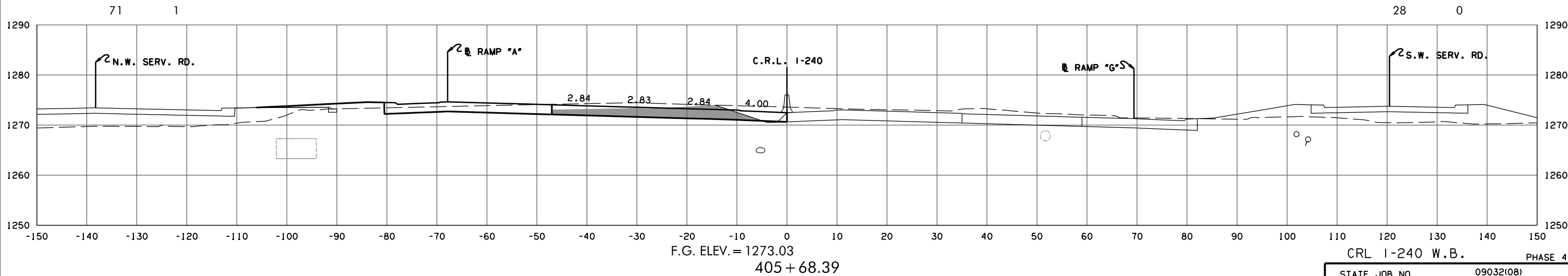
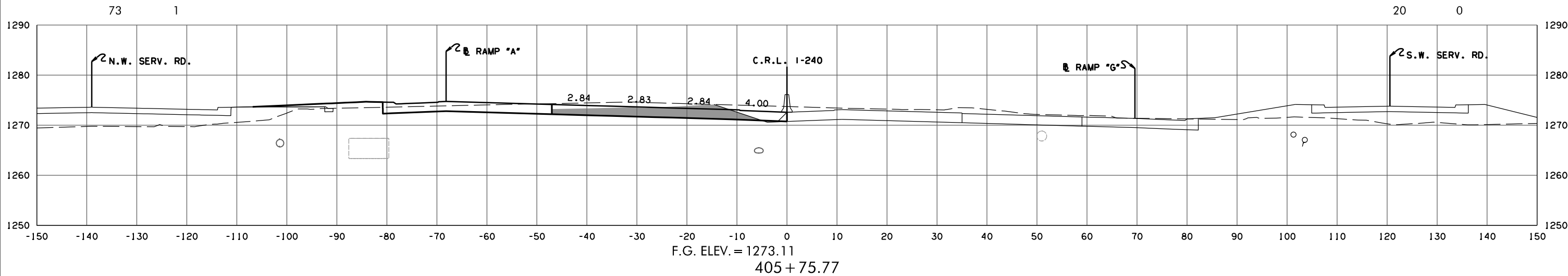
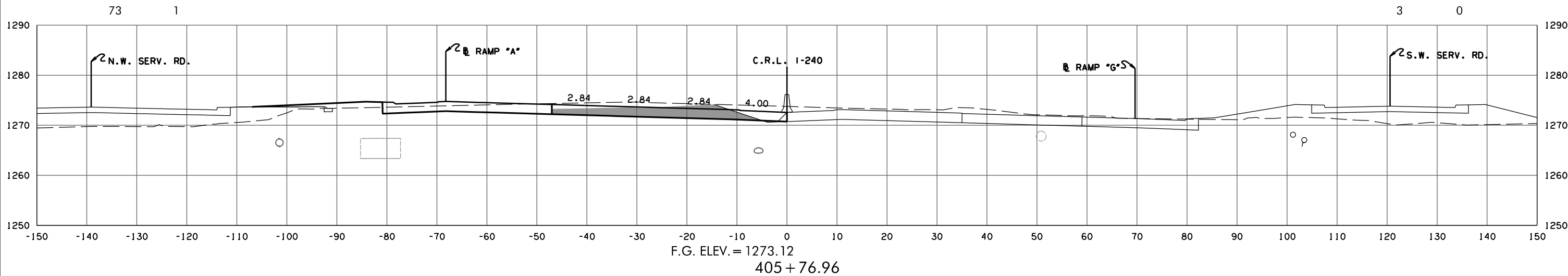

CRL 1-240 W.B. PHASE 4

STATE JOB NO. 09032(08)
OKLAHOMA COUNTY SHEET NO. X021

3/4/2024 3:54:32 PM H:\PROJECTS\2789_CrossRoads_Phase 4\Roadway\Drawings\Sections\0903208-XSEC.CRL - 240.dgn

(CAUTION) THE LOCATION OF ALL UTILITIES AS SHOWN ARE APPROXIMATE. DUE TO RELOCATION'S PLANNED OR PRESENTLY UNDER CONSTRUCTION THERE ARE SOME UTILITIES THAT WILL BE RELOCATED AND NOT SHOWN ON THESE PLANS. THE CONTRACTOR SHALL BE RESPONSIBLE FOR ANY DAMAGE TO ALL UTILITIES.
 DEPTH & LOCATION OF EXISTING UTILITIES SHALL BE FIELD VERIFIED BY THE CONTRACTOR PRIOR TO CONSTRUCTION.

SEE DRAINAGE AREA MAP SHEETS FOR DRAINAGE SYMBOLOLOGY.

R/W & U/E PURCHASED UNDER JP 09032(05)

POB & ASSOCIATES, OKLAHOMA CITY, OK.

90% PLAN SUBMITTAL

3/4/2024

AREA
 CUT FILL

VOLUME
 CUT FILL

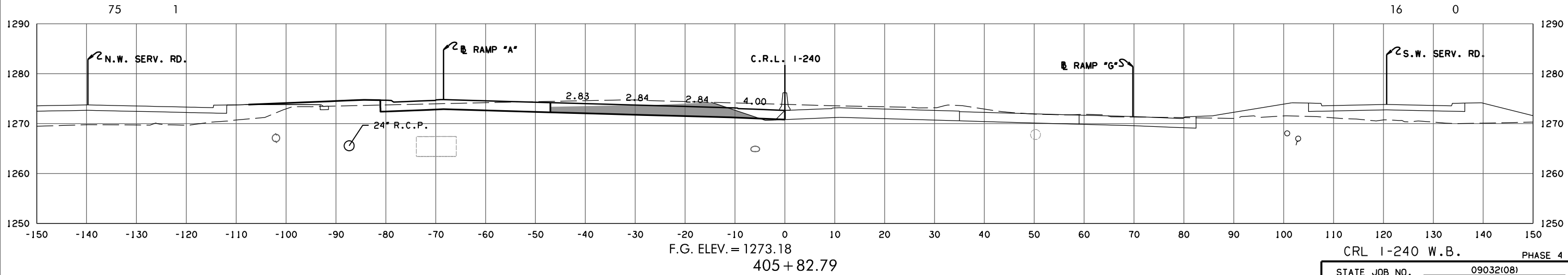
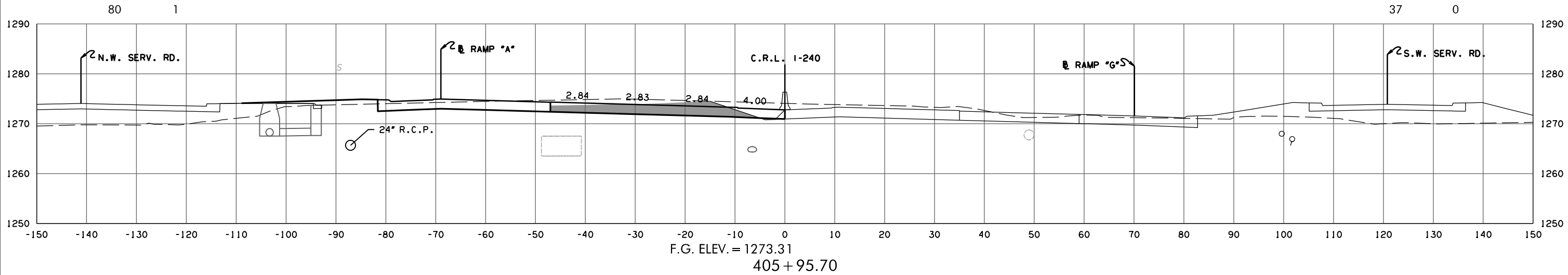
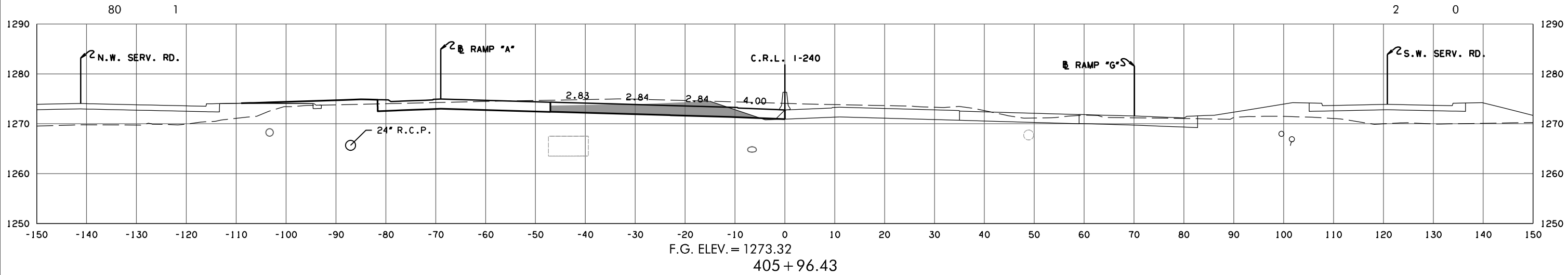

3/4/2024 3:54:34 PM H:\PROJECTS\2789_CrossRoads_Phase 4\Roadway\Drawings\Sections\0903208-XSEC.CRL - 240.dgn

CRL 1-240 W.B. PHASE 4
 STATE JOB NO. 09032(08)
 OKLAHOMA COUNTY SHEET NO. X022

(CAUTION) THE LOCATION OF ALL UTILITIES AS SHOWN ARE APPROXIMATE. DUE TO RELOCATION'S PLANNED OR PRESENTLY UNDER CONSTRUCTION THERE ARE SOME UTILITIES THAT WILL BE RELOCATED AND NOT SHOWN ON THESE PLANS. THE CONTRACTOR SHALL BE RESPONSIBLE FOR ANY DAMAGE TO ALL UTILITIES.
 DEPTH & LOCATION OF EXISTING UTILITIES SHALL BE FIELD VERIFIED BY THE CONTRACTOR PRIOR TO CONSTRUCTION.

SEE DRAINAGE AREA MAP SHEETS FOR DRAINAGE SYMBOLOLOGY.

R/W & U/E PURCHASED UNDER JP 09032(05)

POB & ASSOCIATES, OKLAHOMA CITY, OK.
90% PLAN SUBMITTAL
 3/4/2024

AREA
 CUT FILL

VOLUME
 CUT FILL

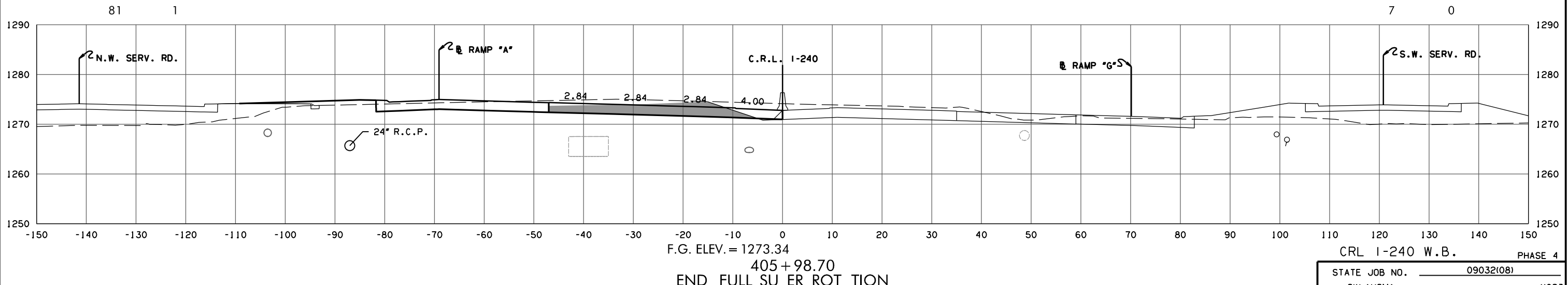
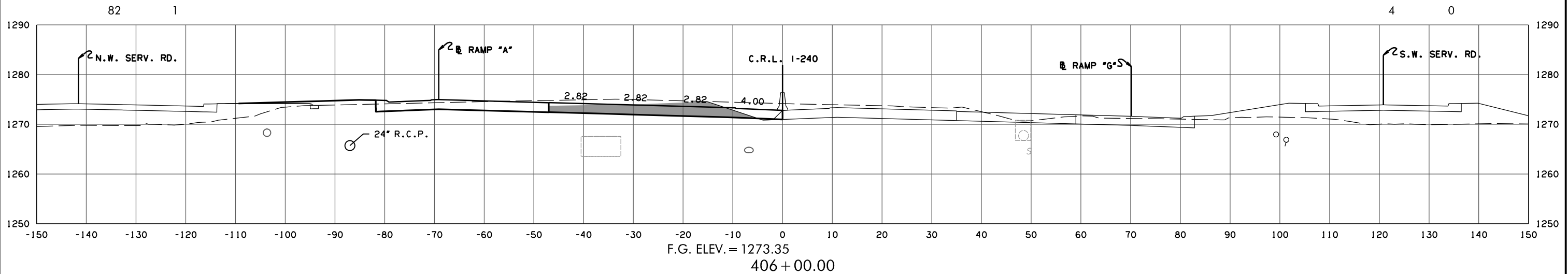
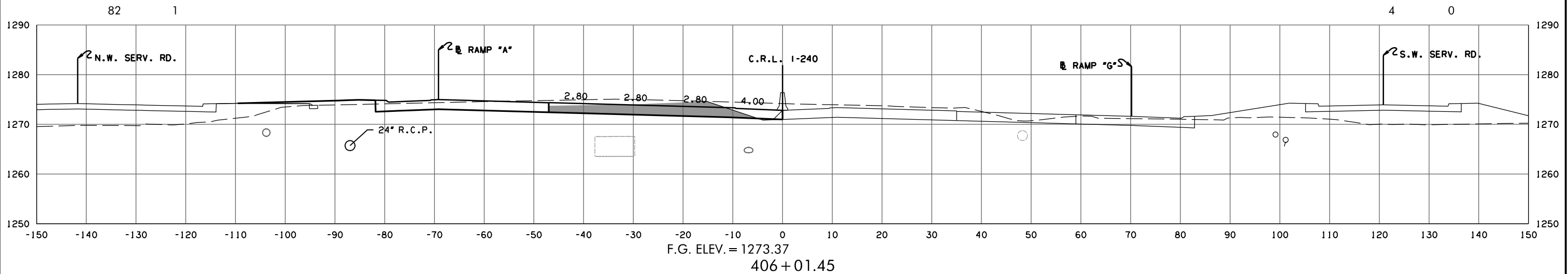

F.G. ELEV. = 1273.34
 405 + 98.70
 END FULL SURVEY

CRL 1-240 W.B. PHASE 4
 STATE JOB NO. 09032(08)
 OKLAHOMA COUNTY SHEET NO. X023

3/4/2024 3:54:36 PM H:\PROJECTS\2789_CrossRoads_Phase 4\Roadway\Drawings\Sections\0903208-XSEC.CRL - 240.dgn

(CAUTION) THE LOCATION OF ALL UTILITIES AS SHOWN ARE APPROXIMATE. DUE TO RELOCATION'S PLANNED OR PRESENTLY UNDER CONSTRUCTION THERE ARE SOME UTILITIES THAT WILL BE RELOCATED AND NOT SHOWN ON THESE PLANS. THE CONTRACTOR SHALL BE RESPONSIBLE FOR ANY DAMAGE TO ALL UTILITIES.

DEPTH & LOCATION OF EXISTING UTILITIES SHALL BE FIELD VERIFIED BY THE CONTRACTOR PRIOR TO CONSTRUCTION.

SEE DRAINAGE AREA MAP SHEETS FOR DRAINAGE SYMBOLOLOGY.

R/W & U/E PURCHASED UNDER JP 09032(05)

POB & ASSOCIATES, OKLAHOMA CITY, OK.

**90% PLAN
SUBMITTAL**

3/4/2024

AREA
CUT FILL

VOLUME
CUT FILL

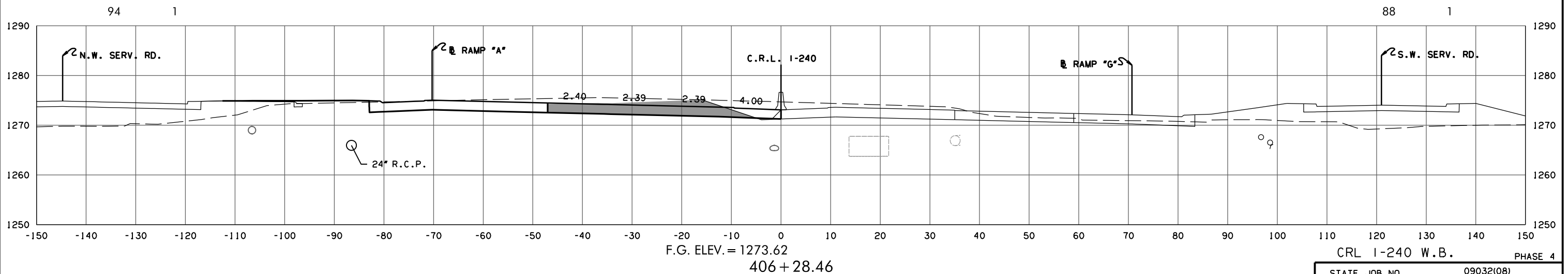
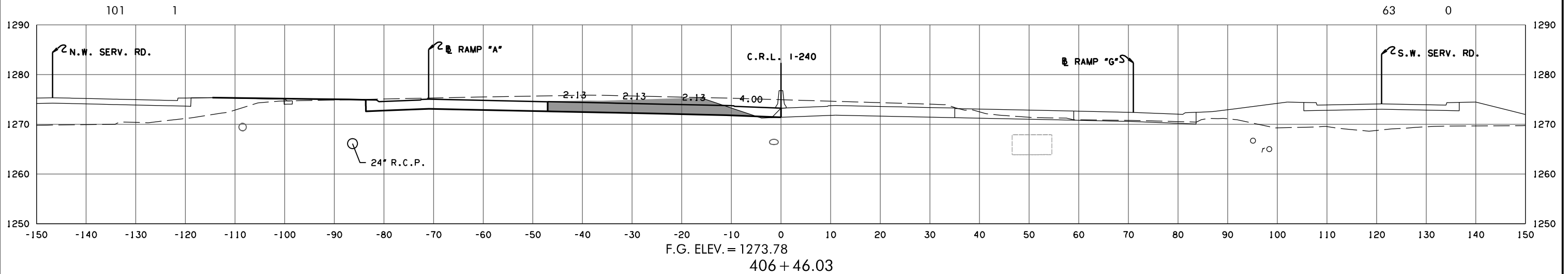
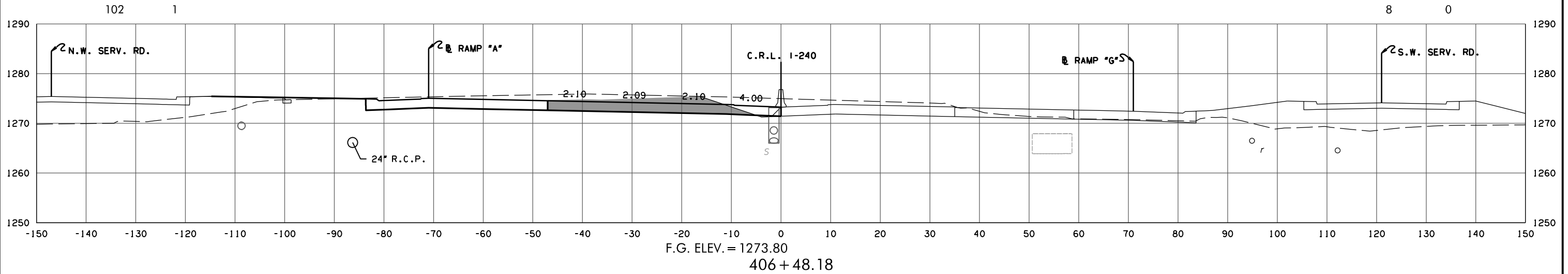

CRL 1-240 W.B. PHASE 4

STATE JOB NO. 09032(08)
OKLAHOMA COUNTY SHEET NO. X024

3/4/2024 3:54:38 PM H:\PROJECTS\2789_CrossRoads_Phase 4\Roadway\Drawings\Sections\0903208-XSEC.CRL - 240.dgn

(CAUTION) THE LOCATION OF ALL UTILITIES AS SHOWN ARE APPROXIMATE. DUE TO RELOCATION'S PLANNED OR PRESENTLY UNDER CONSTRUCTION THERE ARE SOME UTILITIES THAT WILL BE RELOCATED AND NOT SHOWN ON THESE PLANS. THE CONTRACTOR SHALL BE RESPONSIBLE FOR ANY DAMAGE TO ALL UTILITIES.

DEPTH & LOCATION OF EXISTING UTILITIES SHALL BE FIELD VERIFIED BY THE CONTRACTOR PRIOR TO CONSTRUCTION.

SEE DRAINAGE AREA MAP SHEETS FOR DRAINAGE SYMBOLOLOGY.

R/W & U/E PURCHASED UNDER JP 09032(05)

POB & ASSOCIATES, OKLAHOMA CITY, OK.

**90% PLAN
SUBMITTAL**

3/4/2024

AREA
CUT FILL

VOLUME
CUT FILL

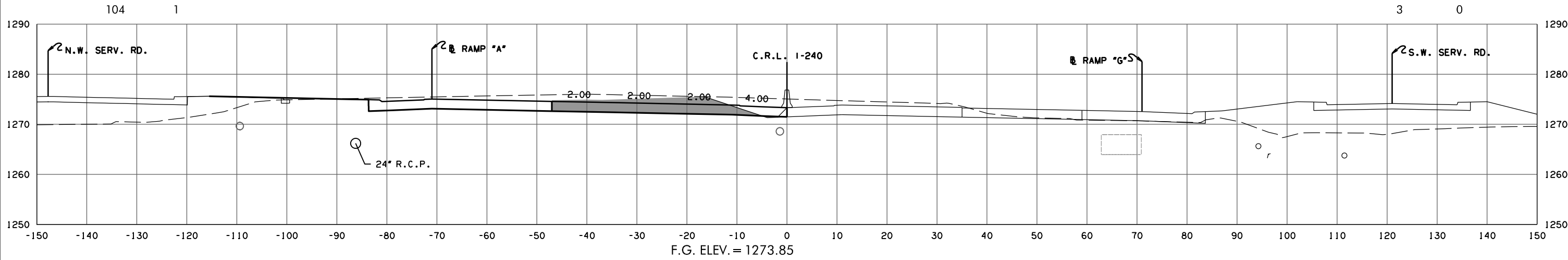

F.G. ELEV. = 1273.85
406 + 54.70
REVERSE CRO N

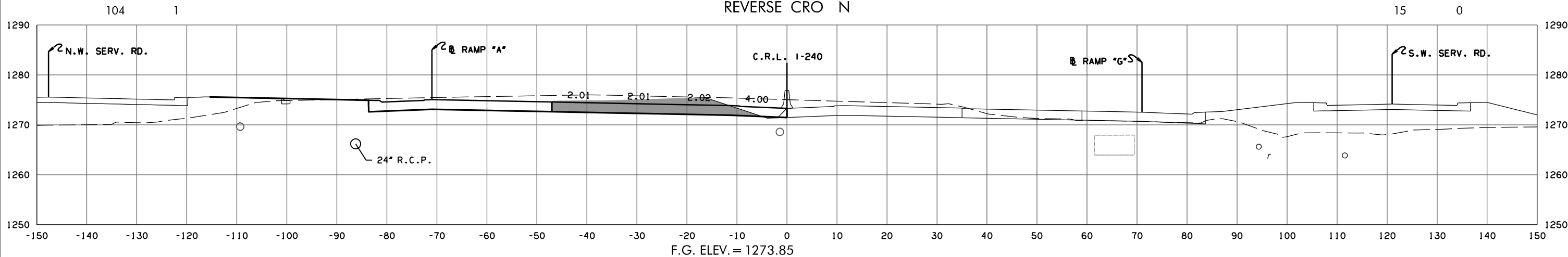

F.G. ELEV. = 1273.85
406 + 53.97

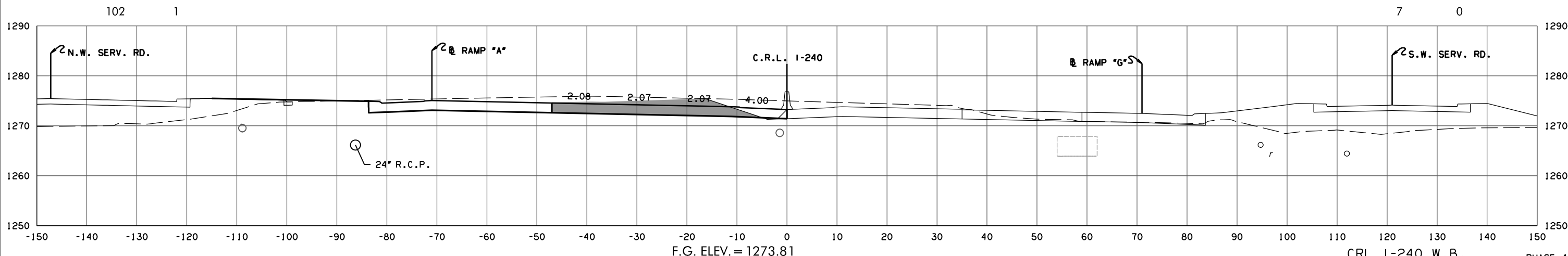

F.G. ELEV. = 1273.81
406 + 50.00

CRL 1-240 W.B. PHASE 4

STATE JOB NO. 09032(08)
OKLAHOMA COUNTY SHEET NO. X025

3/4/2024 3:54:39 PM H:\PROJECTS\2789_CrossRoads_Phase 4\Roadway\Drawings\Sections\0903208-XSEC.CRL - 240.dgn

(CAUTION) THE LOCATION OF ALL UTILITIES AS SHOWN ARE APPROXIMATE. DUE TO RELOCATION'S PLANNED OR PRESENTLY UNDER CONSTRUCTION THERE ARE SOME UTILITIES THAT WILL BE RELOCATED AND NOT SHOWN ON THESE PLANS. THE CONTRACTOR SHALL BE RESPONSIBLE FOR ANY DAMAGE TO ALL UTILITIES.

DEPTH & LOCATION OF EXISTING UTILITIES SHALL BE FIELD VERIFIED BY THE CONTRACTOR PRIOR TO CONSTRUCTION.

SEE DRAINAGE AREA MAP SHEETS FOR DRAINAGE SYMBOLOLOGY.

R/W & U/E PURCHASED UNDER JP 09032(05)

POB & ASSOCIATES, OKLAHOMA CITY, OK.

**90% PLAN
SUBMITTAL**

3/4/2024

AREA
CUT FILL

VOLUME
CUT FILL

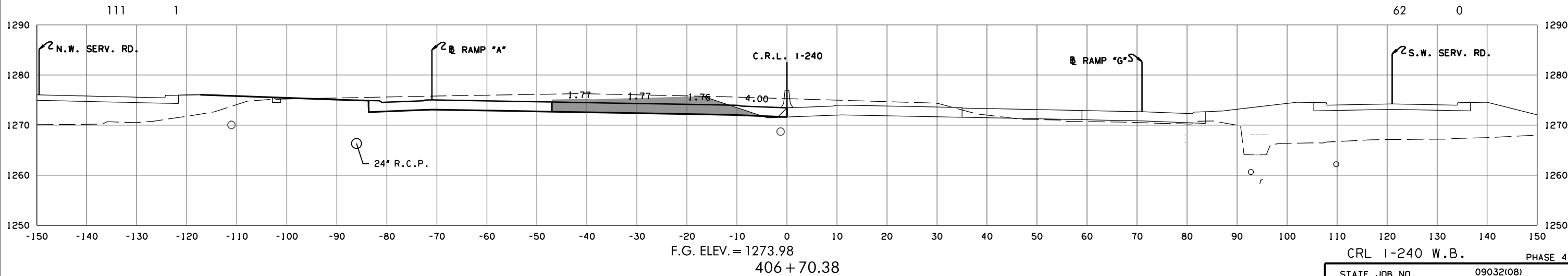
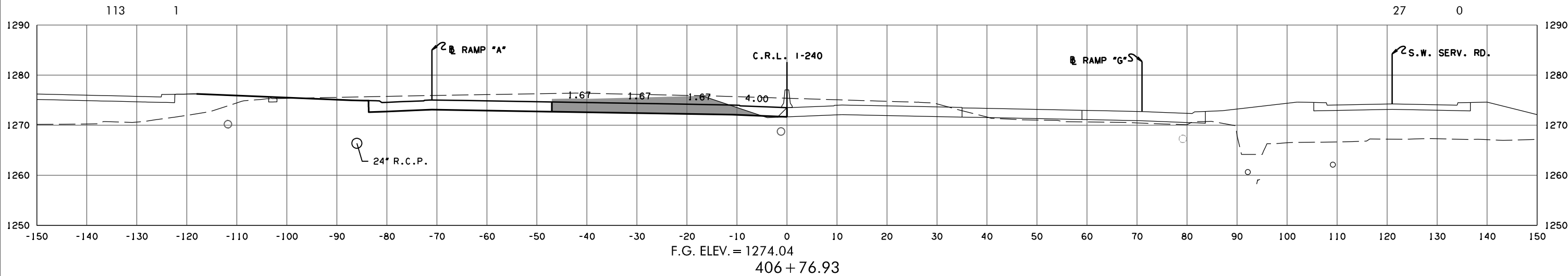
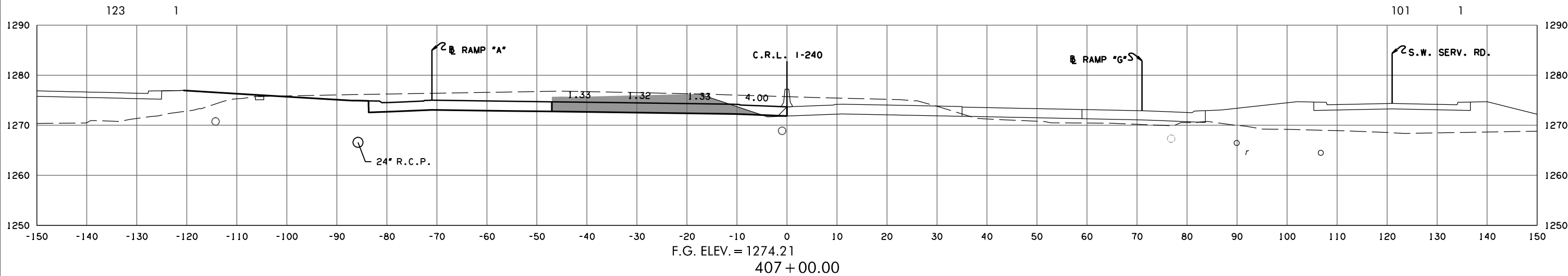

CRL 1-240 W.B. PHASE 4
STATE JOB NO. 09032(08)
OKLAHOMA COUNTY SHEET NO. X026

3/4/2024 3:54:41 PM H:\PROJECTS\2789_CrossRoads_Phase 4\Roadway\Drawings\Sections\0903208-XSEC.CRL - 240.dgn

(CAUTION) THE LOCATION OF ALL UTILITIES AS SHOWN ARE APPROXIMATE. DUE TO RELOCATION'S PLANNED OR PRESENTLY UNDER CONSTRUCTION THERE ARE SOME UTILITIES THAT WILL BE RELOCATED AND NOT SHOWN ON THESE PLANS. THE CONTRACTOR SHALL BE RESPONSIBLE FOR ANY DAMAGE TO ALL UTILITIES.
 DEPTH & LOCATION OF EXISTING UTILITIES SHALL BE FIELD VERIFIED BY THE CONTRACTOR PRIOR TO CONSTRUCTION.

SEE DRAINAGE AREA MAP SHEETS FOR DRAINAGE SYMBOLOLOGY.

R/W & U/E PURCHASED UNDER JP 09032(05)

POB & ASSOCIATES, OKLAHOMA CITY, OK.
90% PLAN SUBMITTAL
 3/4/2024

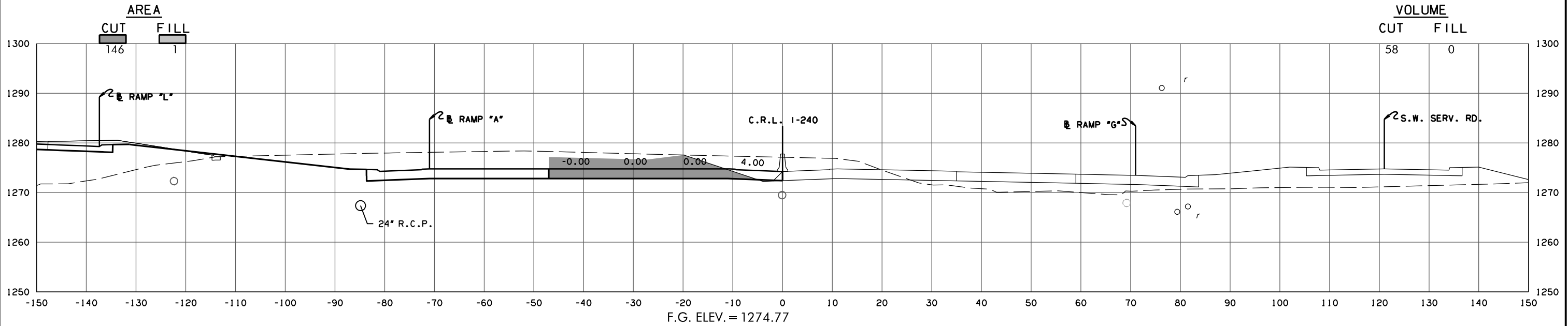

F.G. ELEV. = 1274.77
 407 + 88.03
 FL T

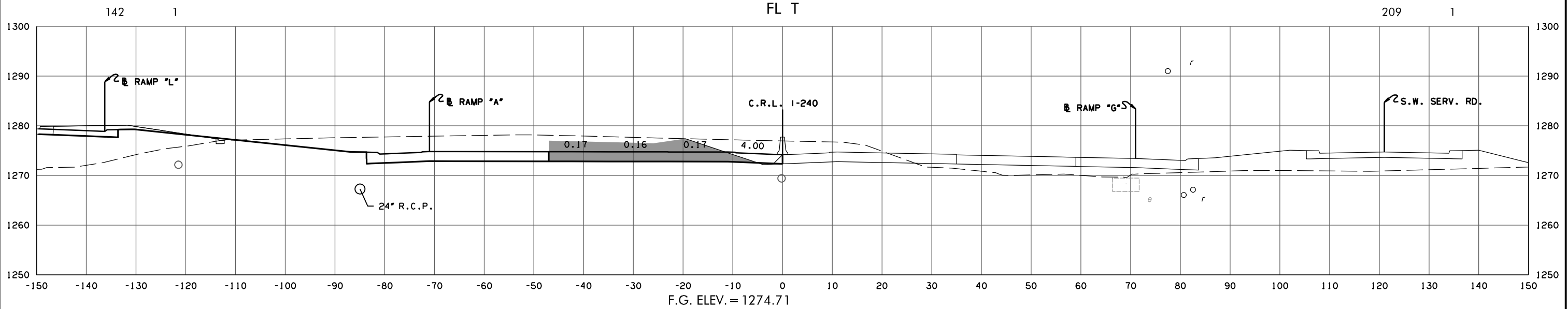

F.G. ELEV. = 1274.71
 407 + 77.15

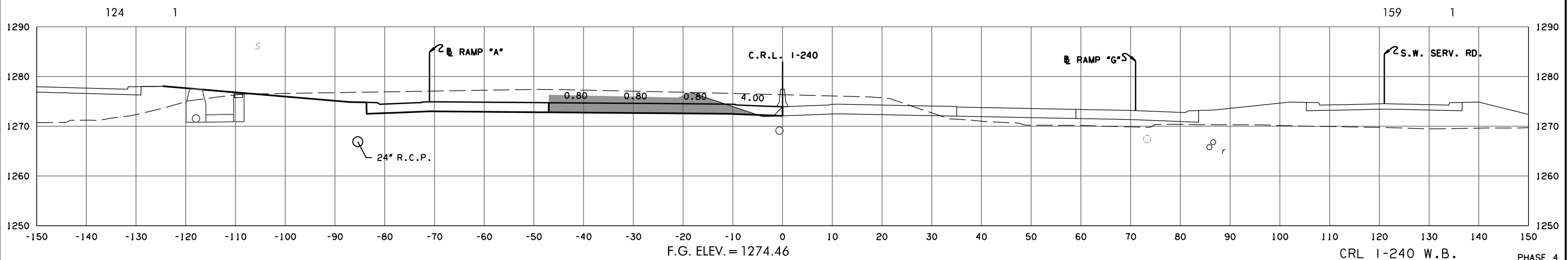

F.G. ELEV. = 1274.46
 407 + 34.75

CRL 1-240 W.B. PHASE 4

STATE JOB NO. 09032(08)
 OKLAHOMA COUNTY SHEET NO. X027

3/4/2024 3:54:43 PM H:\PROJECTS\2789_CrossRoads_Phase 4\Roadway\Drawings\Sections\0903208-XSEC.CRL - 240.dgn

(CAUTION) THE LOCATION OF ALL UTILITIES AS SHOWN ARE APPROXIMATE. DUE TO RELOCATION'S PLANNED OR PRESENTLY UNDER CONSTRUCTION THERE ARE SOME UTILITIES THAT WILL BE RELOCATED AND NOT SHOWN ON THESE PLANS. THE CONTRACTOR SHALL BE RESPONSIBLE FOR ANY DAMAGE TO ALL UTILITIES.
 DEPTH & LOCATION OF EXISTING UTILITIES SHALL BE FIELD VERIFIED BY THE CONTRACTOR PRIOR TO CONSTRUCTION.

SEE DRAINAGE AREA MAP SHEETS FOR DRAINAGE SYMBOLOLOGY.

R/W & U/E PURCHASED UNDER JP 09032(05)

POB & ASSOCIATES, OKLAHOMA CITY, OK.
90% PLAN SUBMITTAL
 3/4/2024

AREA
 CUT FILL

VOLUME
 CUT FILL

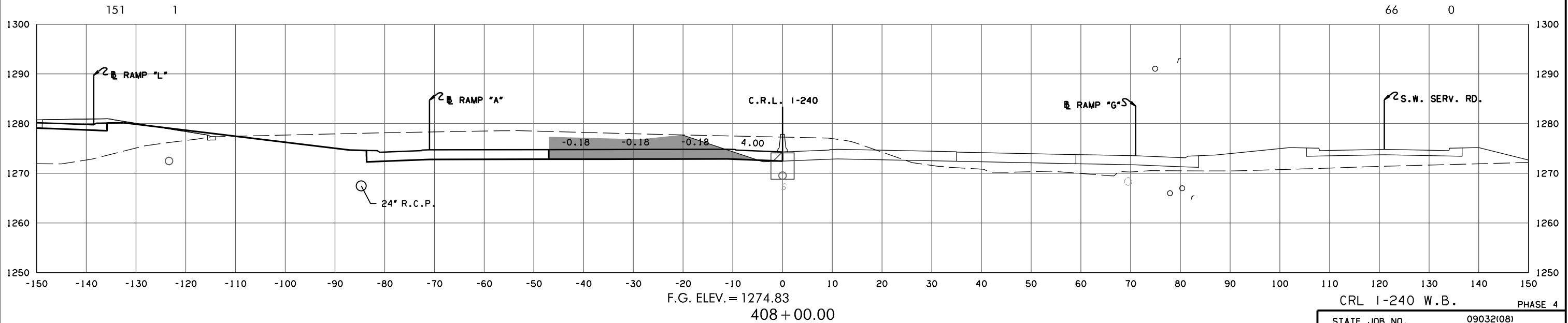
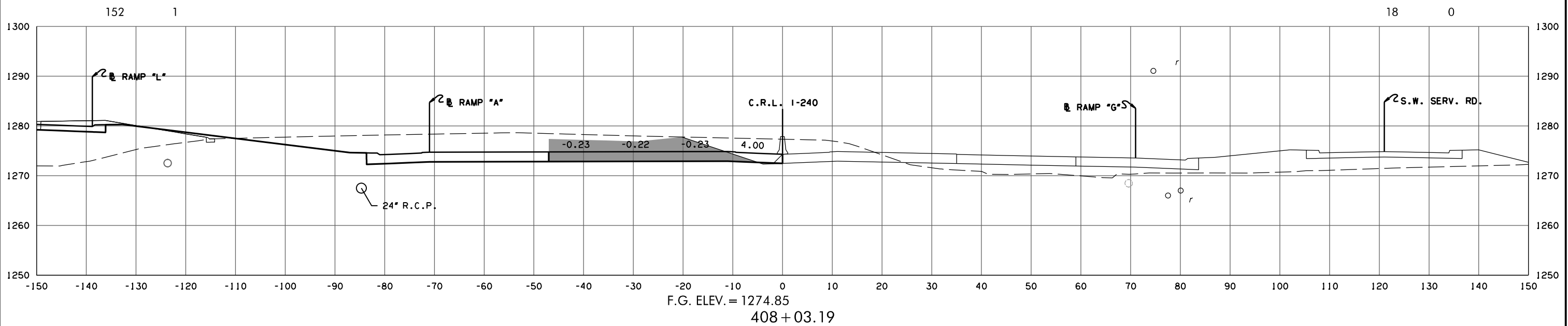

3/4/2024 3:54:44 PM H:\PROJECTS\2789_CrossRoads_Phase 4\Roadway\Drawings\Sections\0903208-XSEC.CRL. - 240.dgn

CRL 1-240 W.B. PHASE 4
 STATE JOB NO. 09032(08)
 OKLAHOMA COUNTY SHEET NO. X028

(CAUTION) THE LOCATION OF ALL UTILITIES AS SHOWN ARE APPROXIMATE. DUE TO RELOCATION'S PLANNED OR PRESENTLY UNDER CONSTRUCTION THERE ARE SOME UTILITIES THAT WILL BE RELOCATED AND NOT SHOWN ON THESE PLANS. THE CONTRACTOR SHALL BE RESPONSIBLE FOR ANY DAMAGE TO ALL UTILITIES.
 DEPTH & LOCATION OF EXISTING UTILITIES SHALL BE FIELD VERIFIED BY THE CONTRACTOR PRIOR TO CONSTRUCTION.

SEE DRAINAGE AREA MAP SHEETS FOR DRAINAGE SYMBOLOLOGY.

R/W & U/E PURCHASED UNDER JP 09032(05)

POB & ASSOCIATES, OKLAHOMA CITY, OK.
90% PLAN SUBMITTAL
 3/4/2024

AREA
 CUT FILL

VOLUME
 CUT FILL

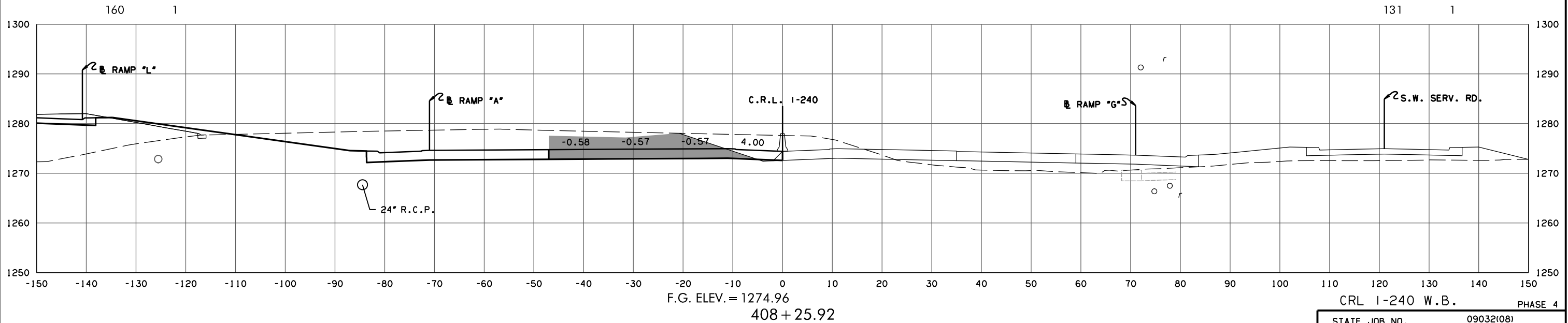
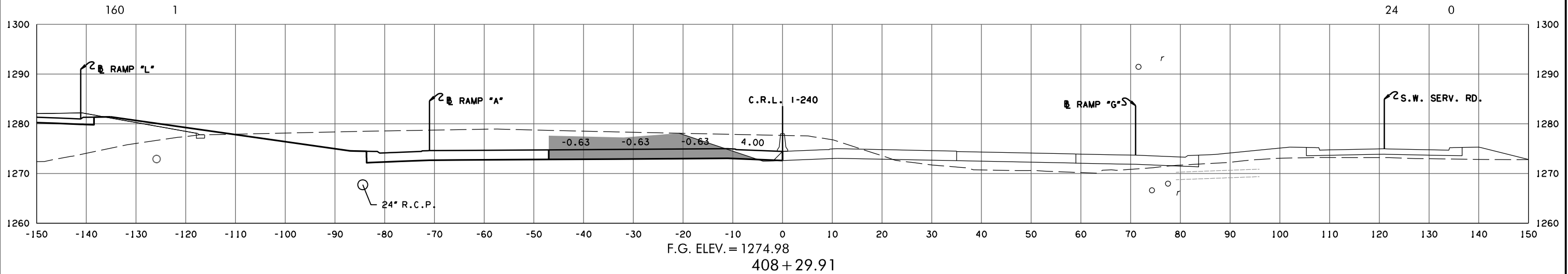
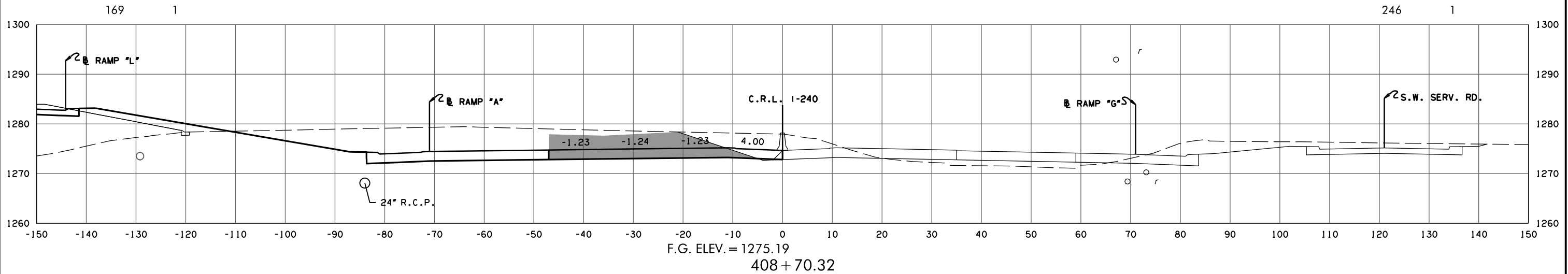

3/4/2024 3:54:46 PM H:\PROJECTS\2789_CrossRoads_Phase 4\Roadway\Drawings\Sections\0903208-XSEC.CRL. - 240.dgn

CRL 1-240 W.B. PHASE 4
 STATE JOB NO. 09032(08)
 OKLAHOMA COUNTY SHEET NO. X029

(CAUTION) THE LOCATION OF ALL UTILITIES AS SHOWN ARE APPROXIMATE. DUE TO RELOCATION'S PLANNED OR PRESENTLY UNDER CONSTRUCTION THERE ARE SOME UTILITIES THAT WILL BE RELOCATED AND NOT SHOWN ON THESE PLANS. THE CONTRACTOR SHALL BE RESPONSIBLE FOR ANY DAMAGE TO ALL UTILITIES.
 DEPTH & LOCATION OF EXISTING UTILITIES SHALL BE FIELD VERIFIED BY THE CONTRACTOR PRIOR TO CONSTRUCTION.

SEE DRAINAGE AREA MAP SHEETS FOR DRAINAGE SYMBOLOLOGY.

R/W & U/E PURCHASED UNDER JP 09032(05)

POB & ASSOCIATES, OKLAHOMA CITY, OK.
90% PLAN SUBMITTAL
 3/4/2024

AREA
 CUT FILL

VOLUME
 CUT FILL

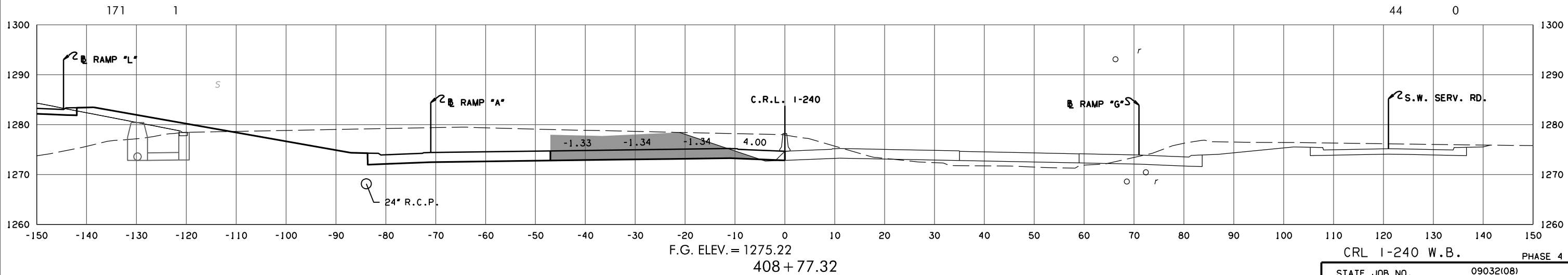
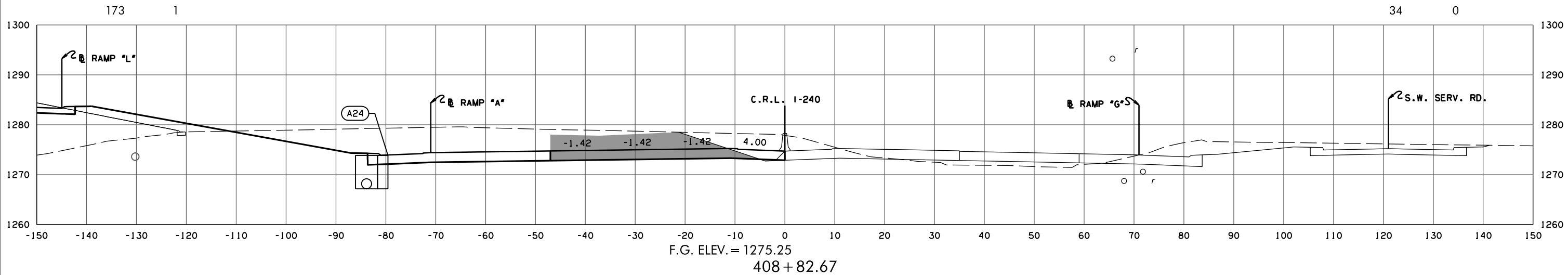
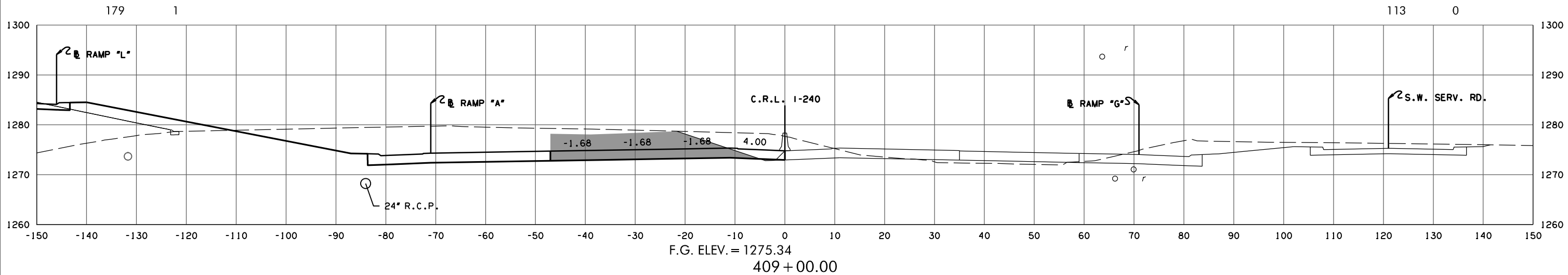

CRL 1-240 W.B. PHASE 4
 STATE JOB NO. 09032(08)
 OKLAHOMA COUNTY SHEET NO. X030

3/4/2024 3:54:48 PM
 H:\PROJECTS\2789_CrossRoads_Phase 4\Roadway\Drawings\Sections\0903208-XSEC.CRL. - 240.dgn

(CAUTION) THE LOCATION OF ALL UTILITIES AS SHOWN ARE APPROXIMATE. DUE TO RELOCATION'S PLANNED OR PRESENTLY UNDER CONSTRUCTION THERE ARE SOME UTILITIES THAT WILL BE RELOCATED AND NOT SHOWN ON THESE PLANS. THE CONTRACTOR SHALL BE RESPONSIBLE FOR ANY DAMAGE TO ALL UTILITIES.
 DEPTH & LOCATION OF EXISTING UTILITIES SHALL BE FIELD VERIFIED BY THE CONTRACTOR PRIOR TO CONSTRUCTION.

SEE DRAINAGE AREA MAP SHEETS FOR DRAINAGE SYMBOLOLOGY.

R/W & U/E PURCHASED UNDER JP 09032(05)

POB & ASSOCIATES, OKLAHOMA CITY, OK.

90% PLAN SUBMITTAL

3/4/2024

AREA
 CUT FILL

VOLUME
 CUT FILL

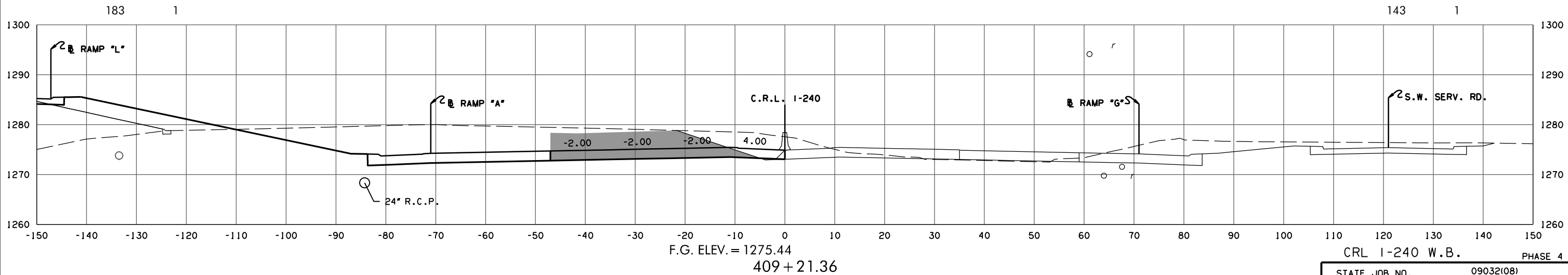
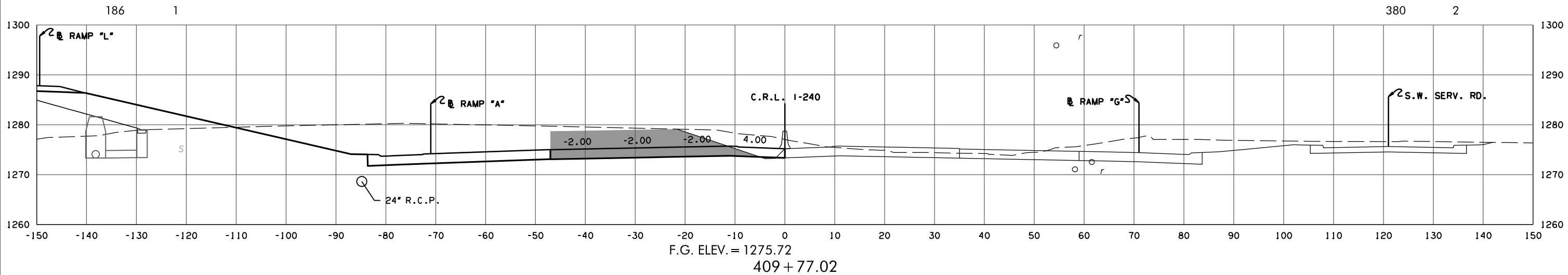
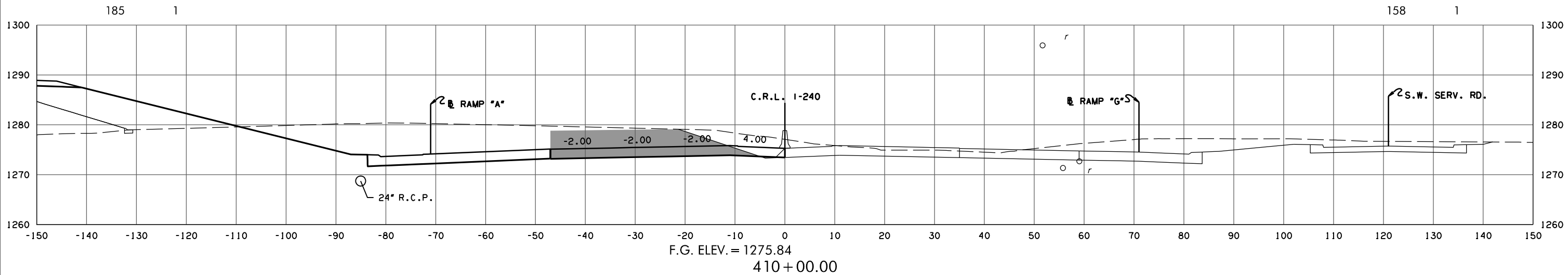

3/4/2024 3:54:50 PM H:\PROJECTS\2789_CrossRoads_Phase 4\Roadway\Drawings\Sections\0903208-XSEC.CRL - 240.dgn

CRL 1-240 W.B. PHASE 4
 STATE JOB NO. 09032(08)
 OKLAHOMA COUNTY SHEET NO. X031

(CAUTION) THE LOCATION OF ALL UTILITIES AS SHOWN ARE APPROXIMATE. DUE TO RELOCATION'S PLANNED OR PRESENTLY UNDER CONSTRUCTION THERE ARE SOME UTILITIES THAT WILL BE RELOCATED AND NOT SHOWN ON THESE PLANS. THE CONTRACTOR SHALL BE RESPONSIBLE FOR ANY DAMAGE TO ALL UTILITIES. DEPTH & LOCATION OF EXISTING UTILITIES SHALL BE FIELD VERIFIED BY THE CONTRACTOR PRIOR TO CONSTRUCTION.

SEE DRAINAGE AREA MAP SHEETS FOR DRAINAGE SYMBOLOLOGY.

R/W & U/E PURCHASED UNDER JP 09032(05)

POB & ASSOCIATES, OKLAHOMA CITY, OK.
90% PLAN
SUBMITTAL
 3/4/2024

AREA
 CUT FILL

VOLUME
 CUT FILL

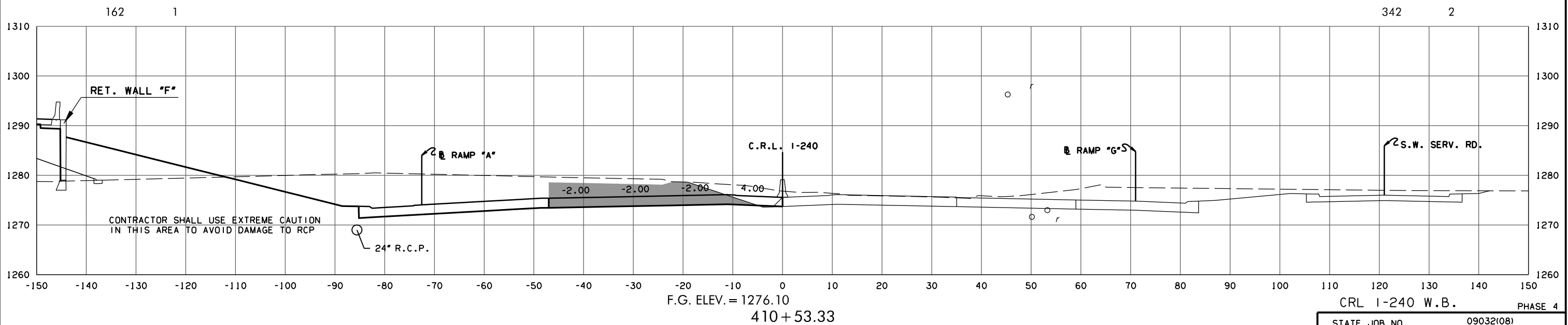
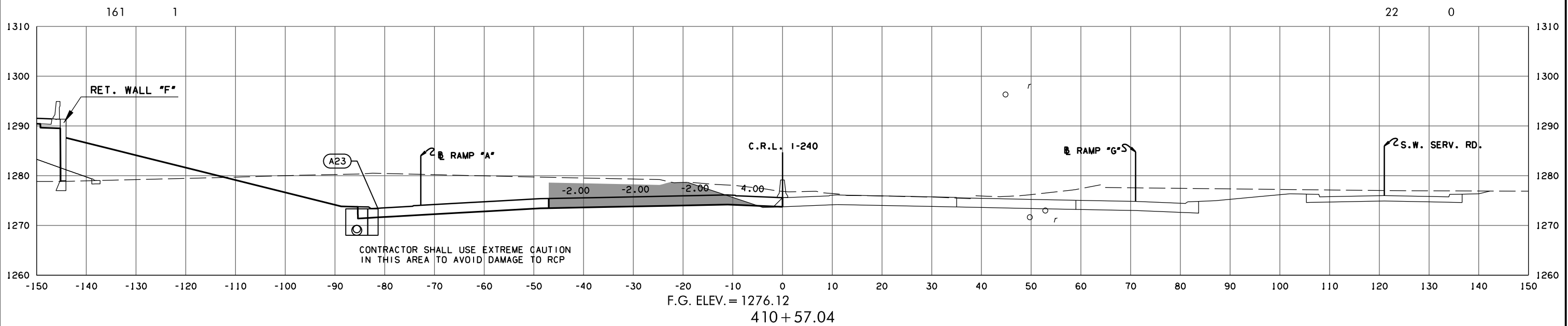

3/4/2024 3:54:52 PM
 H:\PROJECTS\2789_CrossRoads_Phase 4\Roadway\Drawings\Sections\0903208-XSEC.CRL - 240.dgn

CRL 1-240 W.B. PHASE 4
 STATE JOB NO. 09032(08)
 OKLAHOMA COUNTY SHEET NO. X032

(CAUTION) THE LOCATION OF ALL UTILITIES AS SHOWN ARE APPROXIMATE. DUE TO RELOCATION'S PLANNED OR PRESENTLY UNDER CONSTRUCTION THERE ARE SOME UTILITIES THAT WILL BE RELOCATED AND NOT SHOWN ON THESE PLANS. THE CONTRACTOR SHALL BE RESPONSIBLE FOR ANY DAMAGE TO ALL UTILITIES. DEPTH & LOCATION OF EXISTING UTILITIES SHALL BE FIELD VERIFIED BY THE CONTRACTOR PRIOR TO CONSTRUCTION.

SEE DRAINAGE AREA MAP SHEETS FOR DRAINAGE SYMBOLOLOGY.

R/W & U/E PURCHASED UNDER JP 09032(05)

POB & ASSOCIATES, OKLAHOMA CITY, OK.

**90% PLAN
SUBMITTAL**

3/4/2024

AREA
CUT FILL

VOLUME
CUT FILL

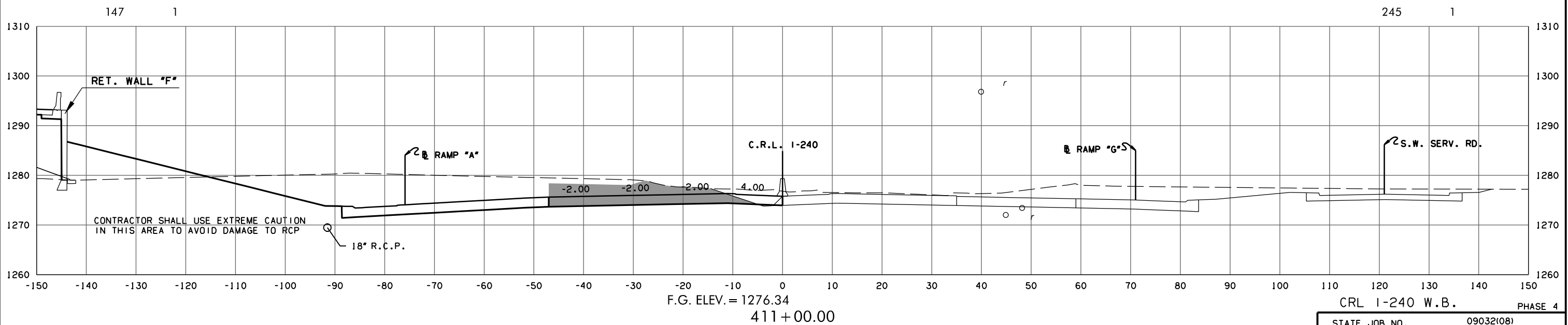
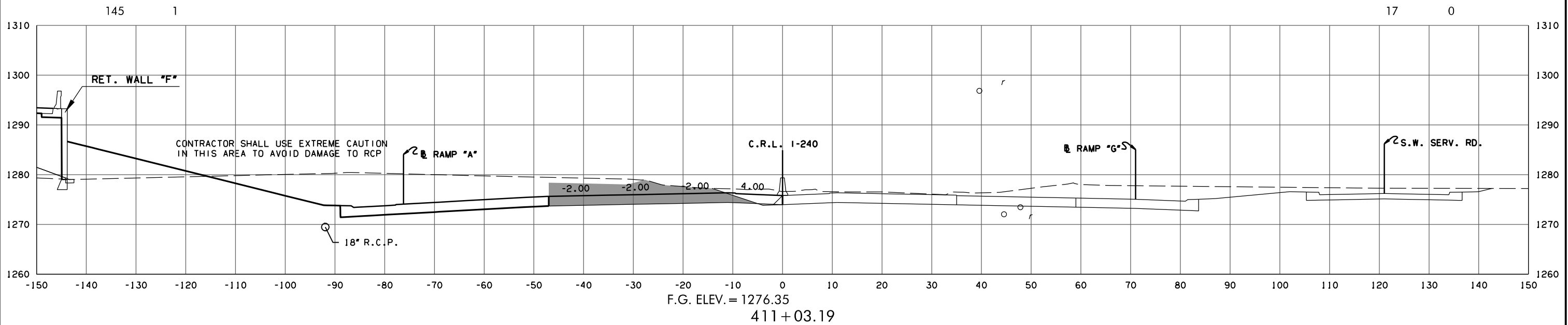

CRL 1-240 W.B. PHASE 4

STATE JOB NO. 09032(08)
OKLAHOMA COUNTY SHEET NO. X033

3/4/2024 3:54:53 PM H:\PROJECTS\2789_CrossRoads_Phase 4\Roadway\Drawings\Sections\0903208-XSEC.CRL - 240.dgn

(CAUTION) THE LOCATION OF ALL UTILITIES AS SHOWN ARE APPROXIMATE. DUE TO RELOCATION'S PLANNED OR PRESENTLY UNDER CONSTRUCTION THERE ARE SOME UTILITIES THAT WILL BE RELOCATED AND NOT SHOWN ON THESE PLANS. THE CONTRACTOR SHALL BE RESPONSIBLE FOR ANY DAMAGE TO ALL UTILITIES. DEPTH & LOCATION OF EXISTING UTILITIES SHALL BE FIELD VERIFIED BY THE CONTRACTOR PRIOR TO CONSTRUCTION.

SEE DRAINAGE AREA MAP SHEETS FOR DRAINAGE SYMBOLOLOGY.

R/W & U/E PURCHASED UNDER JP 09032(05)

POB & ASSOCIATES, OKLAHOMA CITY, OK.
90% PLAN
SUBMITTAL
 3/4/2024

AREA
 CUT FILL

VOLUME
 CUT FILL

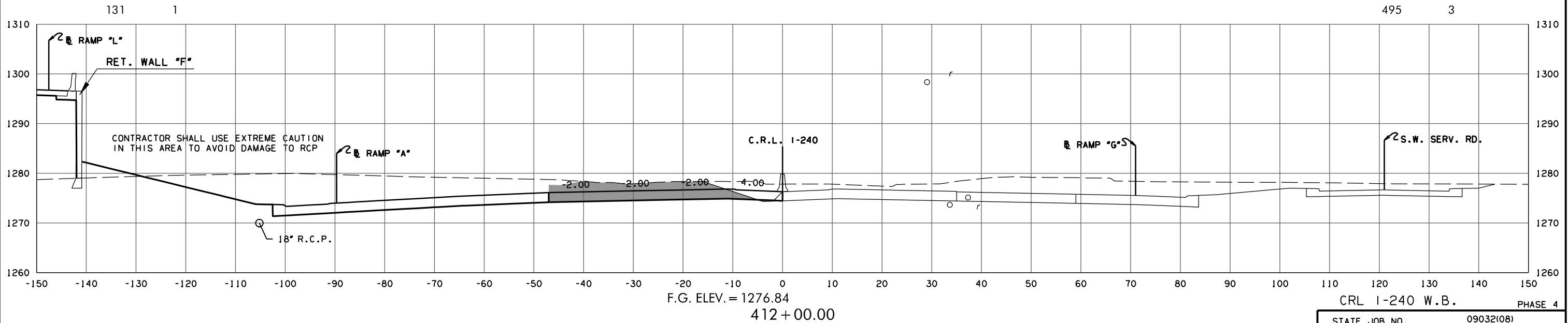
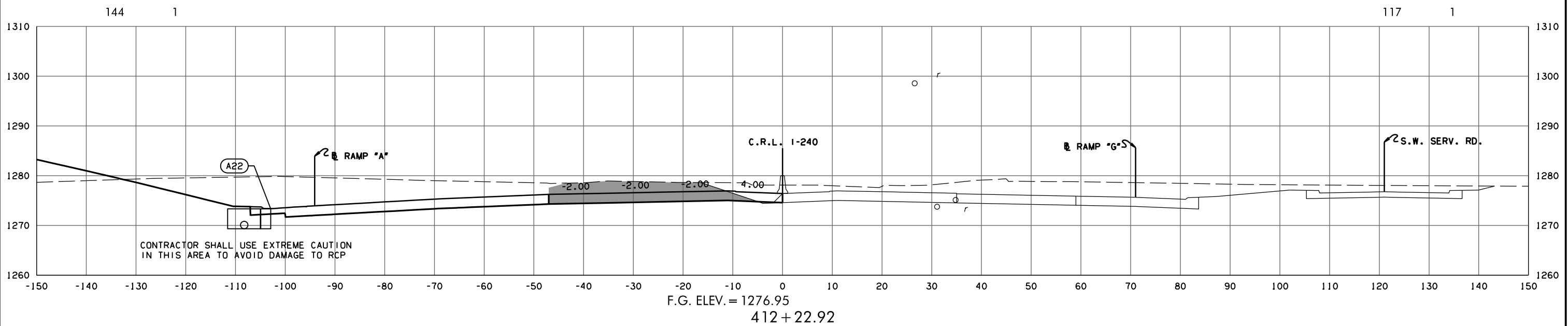

3/4/2024 3:54:55 PM H:\PROJECTS\2789_CrossRoads_Phase 4\Roadway\Drawings\Sections\0903208-XSEC.CRL. - 240.dgn

CRL 1-240 W.B. PHASE 4
 STATE JOB NO. 09032(08)
 OKLAHOMA COUNTY SHEET NO. X034

(CAUTION) THE LOCATION OF ALL UTILITIES AS SHOWN ARE APPROXIMATE. DUE TO RELOCATION'S PLANNED OR PRESENTLY UNDER CONSTRUCTION THERE ARE SOME UTILITIES THAT WILL BE RELOCATED AND NOT SHOWN ON THESE PLANS. THE CONTRACTOR SHALL BE RESPONSIBLE FOR ANY DAMAGE TO ALL UTILITIES. DEPTH & LOCATION OF EXISTING UTILITIES SHALL BE FIELD VERIFIED BY THE CONTRACTOR PRIOR TO CONSTRUCTION.

SEE DRAINAGE AREA MAP SHEETS FOR DRAINAGE SYMBOLOLOGY.

R/W & U/E PURCHASED UNDER JP 09032(05)

POB & ASSOCIATES, OKLAHOMA CITY, OK.
90% PLAN SUBMITTAL
 3/4/2024

AREA
 CUT FILL

VOLUME
 CUT FILL

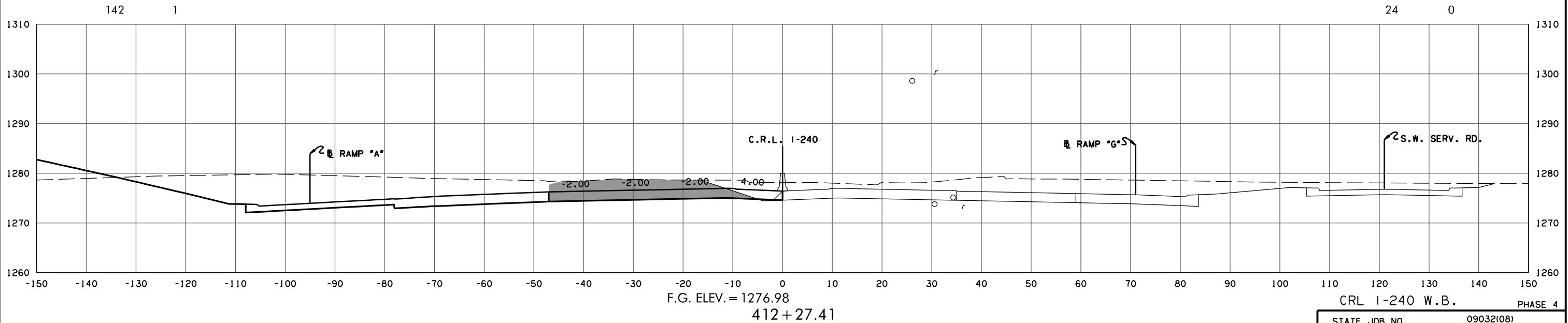
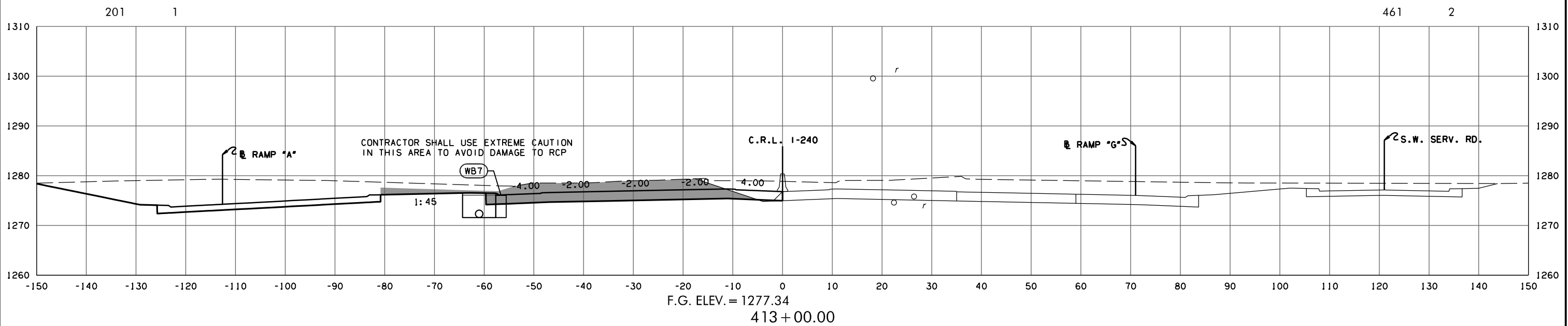

CRL 1-240 W.B. PHASE 4
 STATE JOB NO. 09032(08)
 OKLAHOMA COUNTY SHEET NO. X035

3/4/2024 3:54:57 PM
 H:\PROJECTS\2789_CrossRoads_Phase 4\Roadway\Drawings\Sections\0903208-XSEC.CRL. - 240.dgn

(CAUTION) THE LOCATION OF ALL UTILITIES AS SHOWN ARE APPROXIMATE. DUE TO RELOCATION'S PLANNED OR PRESENTLY UNDER CONSTRUCTION THERE ARE SOME UTILITIES THAT WILL BE RELOCATED AND NOT SHOWN ON THESE PLANS. THE CONTRACTOR SHALL BE RESPONSIBLE FOR ANY DAMAGE TO ALL UTILITIES. DEPTH & LOCATION OF EXISTING UTILITIES SHALL BE FIELD VERIFIED BY THE CONTRACTOR PRIOR TO CONSTRUCTION.

SEE DRAINAGE AREA MAP SHEETS FOR DRAINAGE SYMBOLOLOGY.

R/W & U/E PURCHASED UNDER JP 09032(05)

POB & ASSOCIATES, OKLAHOMA CITY, OK.

**90% PLAN
SUBMITTAL**

3/4/2024

AREA
CUT FILL

VOLUME
CUT FILL

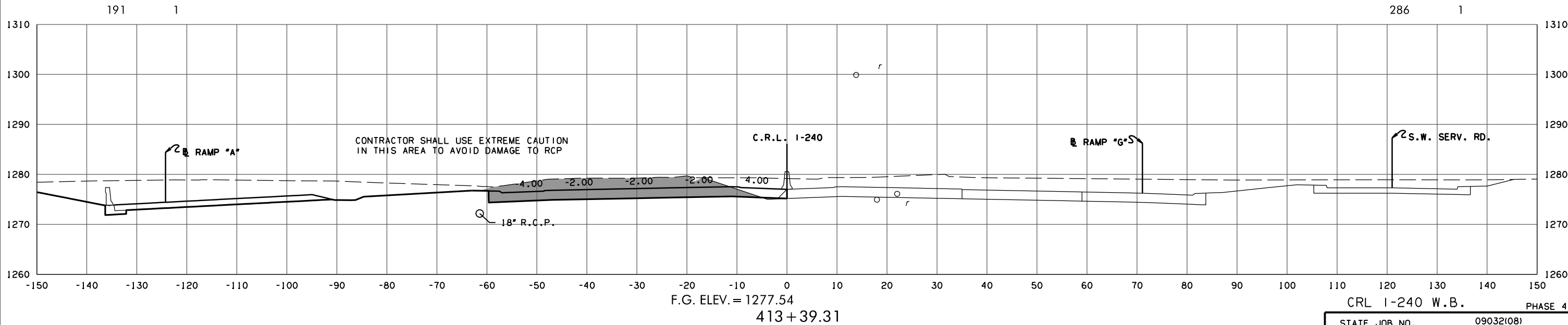
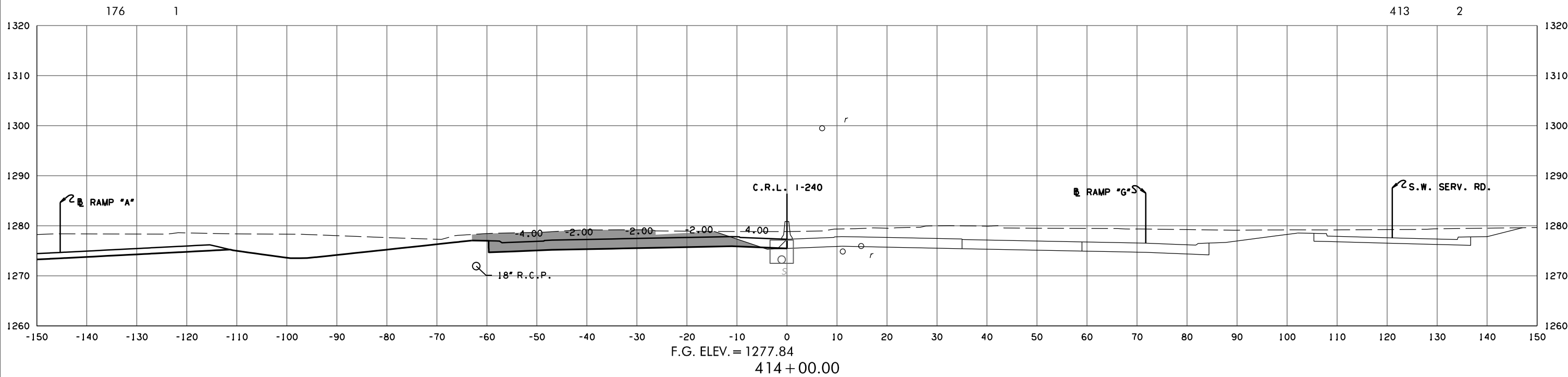

CRL 1-240 W.B. PHASE 4
STATE JOB NO. 09032(08)
OKLAHOMA COUNTY SHEET NO. X036

3/4/2024 3:54:58 PM H:\PROJECTS\2789_CrossRoads_Phase 4\Roadway\Drawings\Sections\0903208-XSEC-CRL - 240.dgn

(CAUTION) THE LOCATION OF ALL UTILITIES AS SHOWN ARE APPROXIMATE. DUE TO RELOCATION'S PLANNED OR PRESENTLY UNDER CONSTRUCTION THERE ARE SOME UTILITIES THAT WILL BE RELOCATED AND NOT SHOWN ON THESE PLANS. THE CONTRACTOR SHALL BE RESPONSIBLE FOR ANY DAMAGE TO ALL UTILITIES.
 DEPTH & LOCATION OF EXISTING UTILITIES SHALL BE FIELD VERIFIED BY THE CONTRACTOR PRIOR TO CONSTRUCTION.

SEE DRAINAGE AREA MAP SHEETS FOR DRAINAGE SYMBOLOLOGY.

R/W & U/E PURCHASED UNDER JP 09032(05)

POB & ASSOCIATES, OKLAHOMA CITY, OK.
90% PLAN SUBMITTAL
 3/4/2024

AREA
 CUT FILL

VOLUME
 CUT FILL

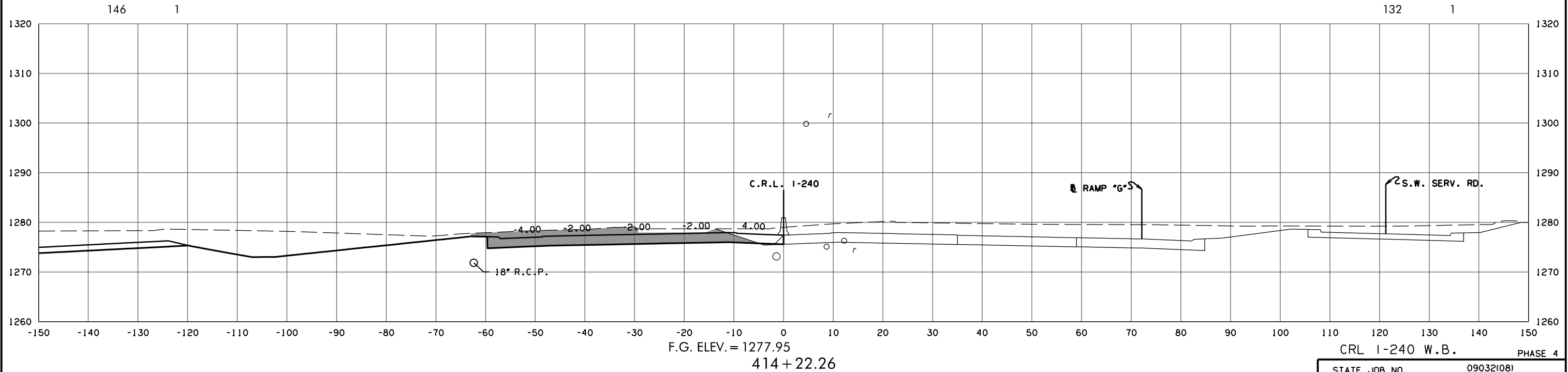
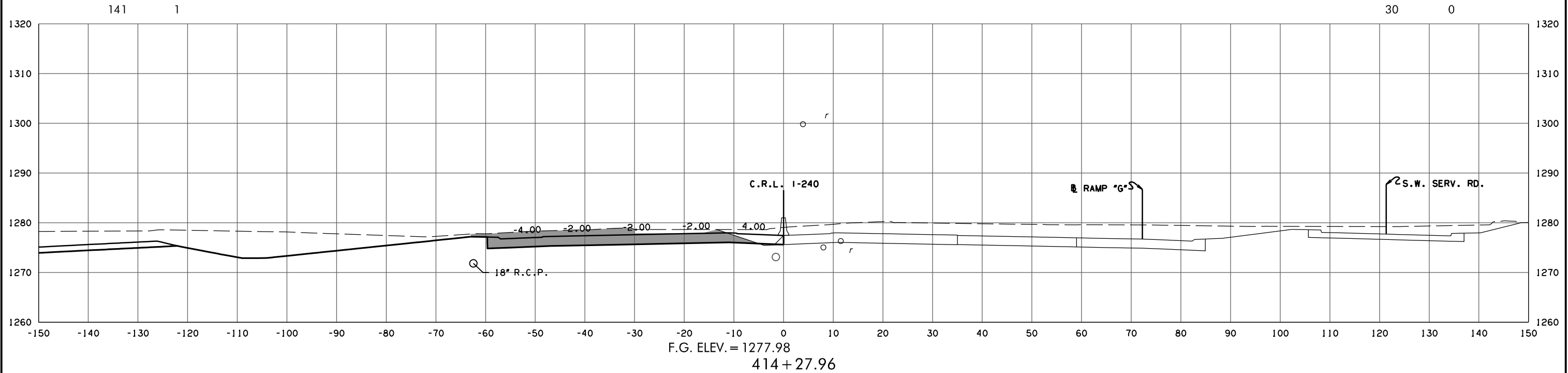

CRL I-240 W.B. PHASE 4
 STATE JOB NO. 09032(08)
 OKLAHOMA COUNTY SHEET NO. X037

3/4/2024 3:55:00 PM H:\PROJECTS\2789_CrossRoads_Phase 4\Roadway\Drawings\Sections\0903208-XSEC.CRL - 240.dgn

(CAUTION) THE LOCATION OF ALL UTILITIES AS SHOWN ARE APPROXIMATE. DUE TO RELOCATION'S PLANNED OR PRESENTLY UNDER CONSTRUCTION THERE ARE SOME UTILITIES THAT WILL BE RELOCATED AND NOT SHOWN ON THESE PLANS. THE CONTRACTOR SHALL BE RESPONSIBLE FOR ANY DAMAGE TO ALL UTILITIES.
 DEPTH & LOCATION OF EXISTING UTILITIES SHALL BE FIELD VERIFIED BY THE CONTRACTOR PRIOR TO CONSTRUCTION.

SEE DRAINAGE AREA MAP SHEETS FOR DRAINAGE SYMBOLOLOGY.

R/W & U/E PURCHASED UNDER JP 09032(05)

POB & ASSOCIATES, OKLAHOMA CITY, OK.
90% PLAN SUBMITTAL
 3/4/2024

AREA
 CUT FILL

VOLUME
 CUT FILL

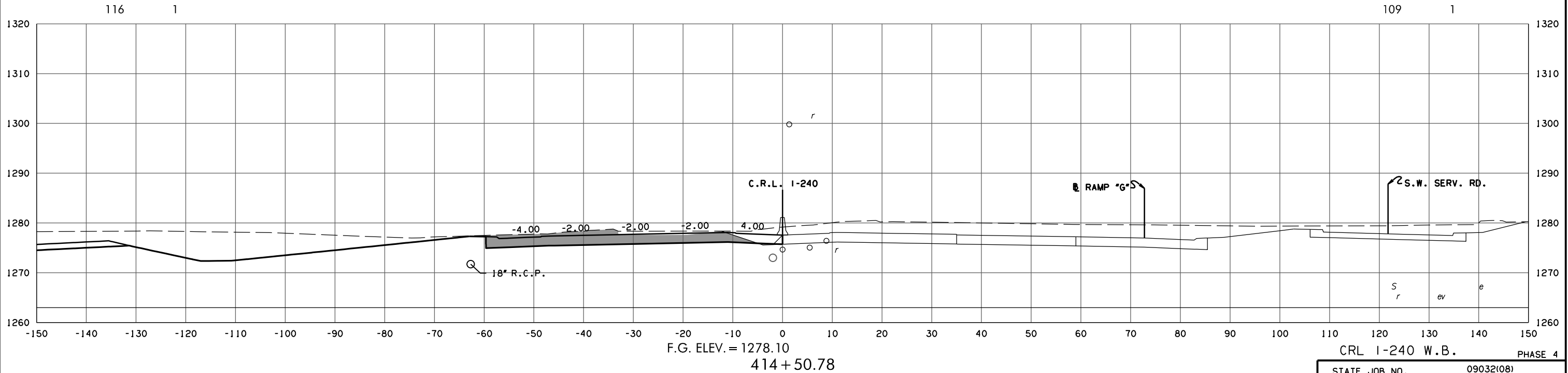
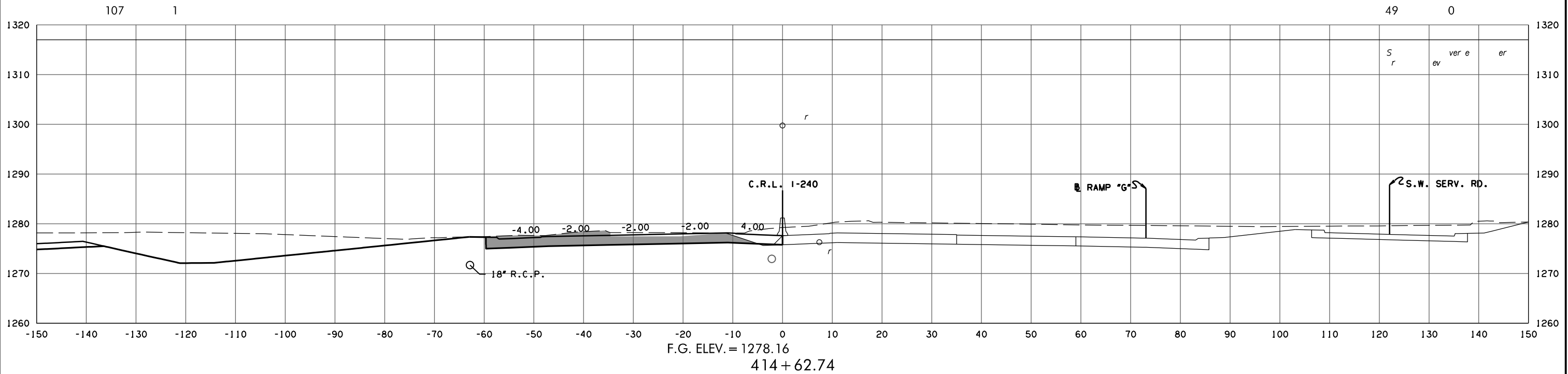

3/4/2024 3:55:02 PM H:\PROJECTS\2789_CrossRoads_Phase 4\Roadway\Drawings\Sections\0903208-XSEC.CRL. - 240.dgn

CRL 1-240 W.B. PHASE 4
 STATE JOB NO. 09032(08)
 OKLAHOMA COUNTY SHEET NO. X038

(CAUTION) THE LOCATION OF ALL UTILITIES AS SHOWN ARE APPROXIMATE. DUE TO RELOCATION'S PLANNED OR PRESENTLY UNDER CONSTRUCTION THERE ARE SOME UTILITIES THAT WILL BE RELOCATED AND NOT SHOWN ON THESE PLANS. THE CONTRACTOR SHALL BE RESPONSIBLE FOR ANY DAMAGE TO ALL UTILITIES.
 DEPTH & LOCATION OF EXISTING UTILITIES SHALL BE FIELD VERIFIED BY THE CONTRACTOR PRIOR TO CONSTRUCTION.

SEE DRAINAGE AREA MAP SHEETS FOR DRAINAGE SYMBOLOLOGY.

R/W & U/E PURCHASED UNDER JP 09032(05)

POB & ASSOCIATES, OKLAHOMA CITY, OK.
90% PLAN
SUBMITTAL
 3/4/2024

AREA
 CUT FILL

VOLUME
 CUT FILL

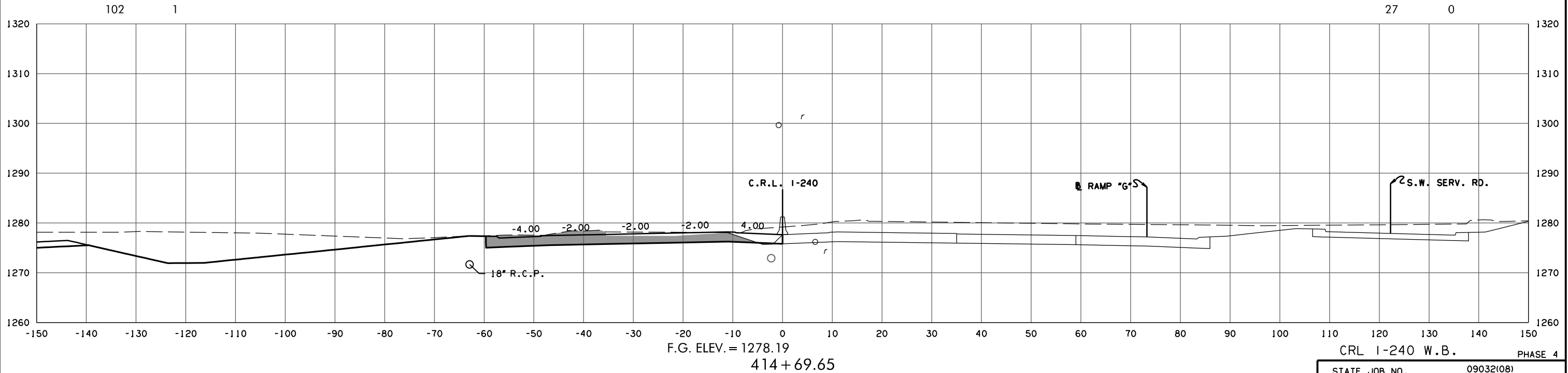
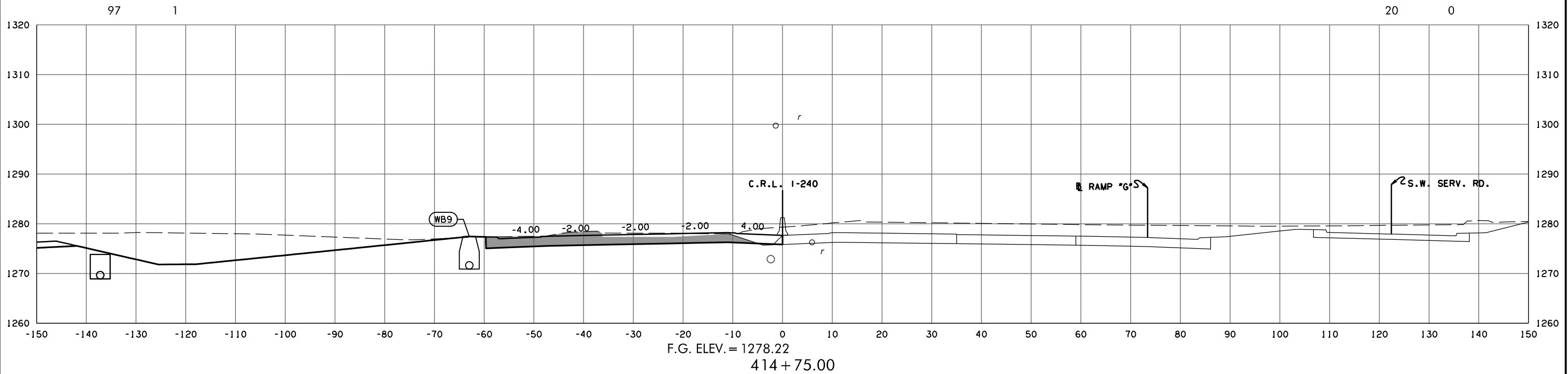

3/4/2024 3:55:03 PM H:\PROJECTS\2789_CrossRoads_Phase 4\Roadway\Drawings\Sections\0903208-XSEC.CRL. - 240.dgn

CRL 1-240 W.B. PHASE 4
 STATE JOB NO. 09032(08)
 OKLAHOMA COUNTY SHEET NO. X039

(CAUTION) THE LOCATION OF ALL UTILITIES AS SHOWN ARE APPROXIMATE. DUE TO RELOCATION'S PLANNED OR PRESENTLY UNDER CONSTRUCTION THERE ARE SOME UTILITIES THAT WILL BE RELOCATED AND NOT SHOWN ON THESE PLANS. THE CONTRACTOR SHALL BE RESPONSIBLE FOR ANY DAMAGE TO ALL UTILITIES.
 DEPTH & LOCATION OF EXISTING UTILITIES SHALL BE FIELD VERIFIED BY THE CONTRACTOR PRIOR TO CONSTRUCTION.

SEE DRAINAGE AREA MAP SHEETS FOR DRAINAGE SYMBOLOLOGY.

R/W & U/E PURCHASED UNDER JP 09032(05)

POB & ASSOCIATES, OKLAHOMA CITY, OK.
90% PLAN SUBMITTAL
 3/4/2024

AREA
 CUT FILL

VOLUME
 CUT FILL

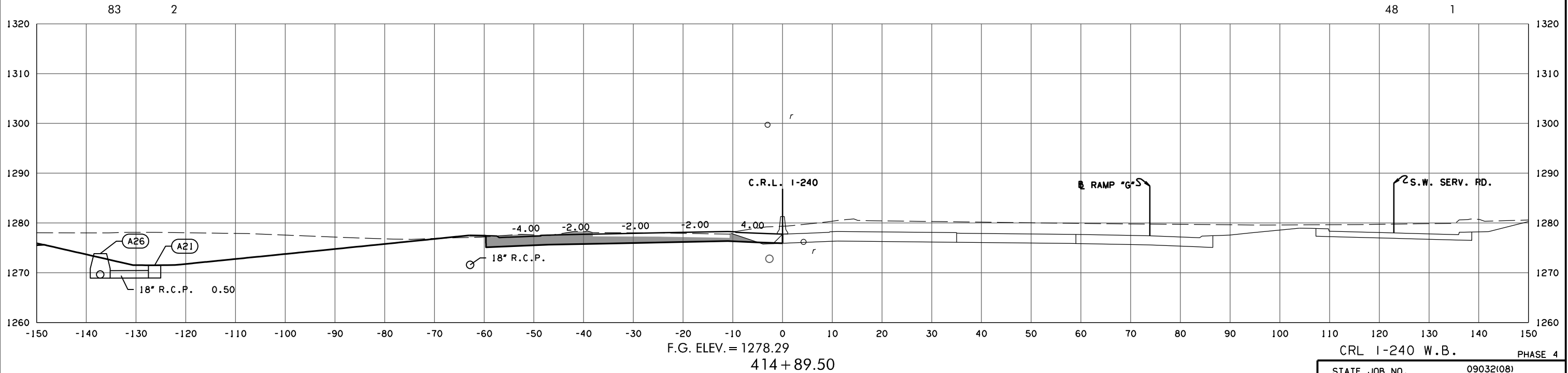
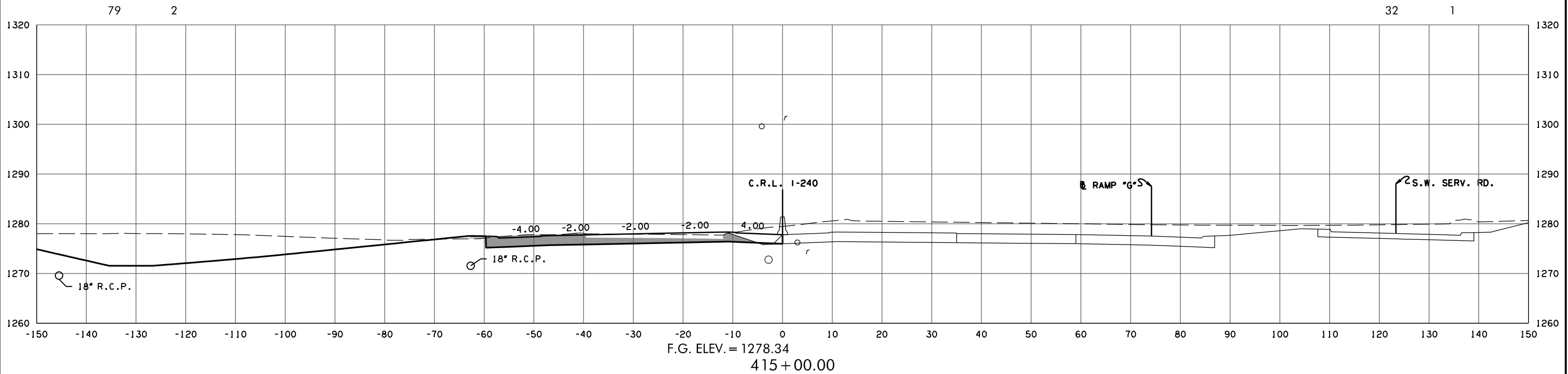

CRL 1-240 W.B. PHASE 4
 STATE JOB NO. 09032(08)
 OKLAHOMA COUNTY SHEET NO. X040

3/4/2024 3:55:05 PM
 H:\PROJECTS\2789_CrossRoads_Phase 4\Roadway\Drawings\Sections\0903208-XSEC.CRL - 240.dgn

(CAUTION) THE LOCATION OF ALL UTILITIES AS SHOWN ARE APPROXIMATE. DUE TO RELOCATION'S PLANNED OR PRESENTLY UNDER CONSTRUCTION THERE ARE SOME UTILITIES THAT WILL BE RELOCATED AND NOT SHOWN ON THESE PLANS. THE CONTRACTOR SHALL BE RESPONSIBLE FOR ANY DAMAGE TO ALL UTILITIES.
 DEPTH & LOCATION OF EXISTING UTILITIES SHALL BE FIELD VERIFIED BY THE CONTRACTOR PRIOR TO CONSTRUCTION.

SEE DRAINAGE AREA MAP SHEETS FOR DRAINAGE SYMBOLOLOGY.

R/W & U/E PURCHASED UNDER JP 09032(05)

POB & ASSOCIATES, OKLAHOMA CITY, OK.
90% PLAN SUBMITTAL
 3/4/2024

AREA
 CUT FILL

VOLUME
 CUT FILL

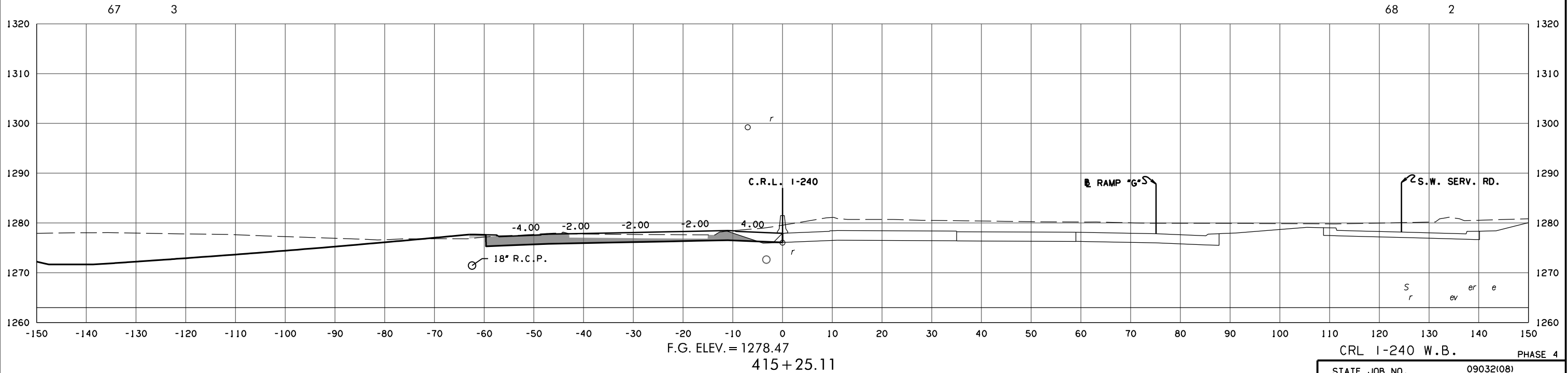
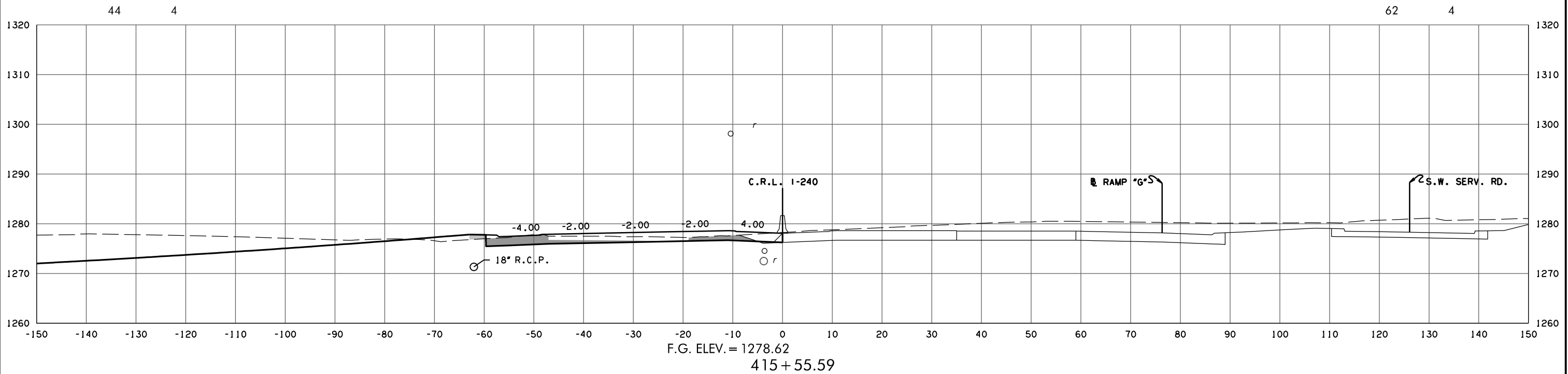

3/4/2024 3:55:07 PM H:\PROJECTS\2789_CrossRoads_Phase 4\Roadway\Drawings\Sections\0903208-XSEC.CRL - 240.dgn

CRL 1-240 W.B. PHASE 4
 STATE JOB NO. 09032(08)
 OKLAHOMA COUNTY SHEET NO. X041

(CAUTION) THE LOCATION OF ALL UTILITIES AS SHOWN ARE APPROXIMATE. DUE TO RELOCATION'S PLANNED OR PRESENTLY UNDER CONSTRUCTION THERE ARE SOME UTILITIES THAT WILL BE RELOCATED AND NOT SHOWN ON THESE PLANS. THE CONTRACTOR SHALL BE RESPONSIBLE FOR ANY DAMAGE TO ALL UTILITIES.
 DEPTH & LOCATION OF EXISTING UTILITIES SHALL BE FIELD VERIFIED BY THE CONTRACTOR PRIOR TO CONSTRUCTION.

SEE DRAINAGE AREA MAP SHEETS FOR DRAINAGE SYMBOLOLOGY.

R/W & U/E PURCHASED UNDER JP 09032(05)

POB & ASSOCIATES, OKLAHOMA CITY, OK.
90% PLAN SUBMITTAL
 3/4/2024

AREA
 CUT FILL

VOLUME
 CUT FILL

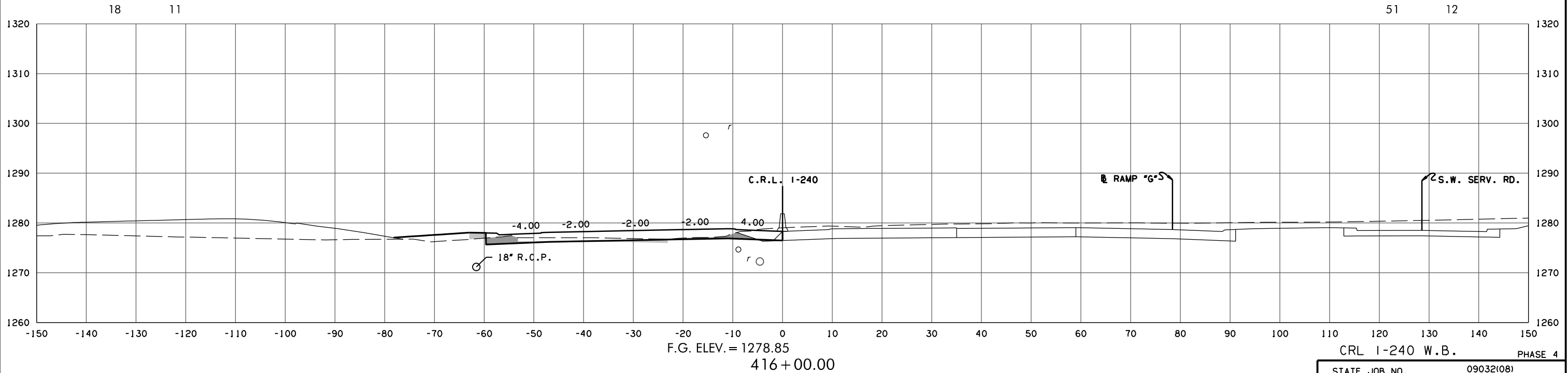
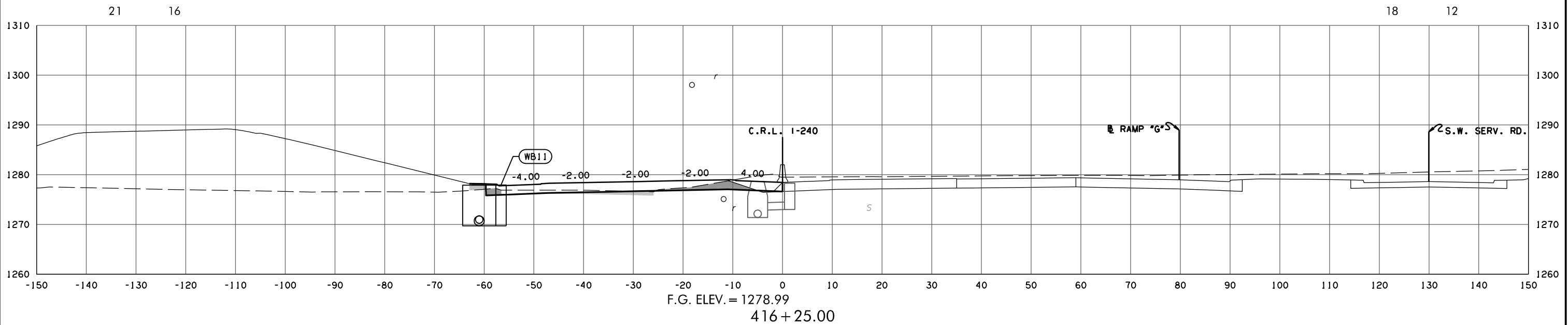

CRL 1-240 W.B. PHASE 4
 STATE JOB NO. 09032(08)
 OKLAHOMA COUNTY SHEET NO. X042

3/4/2024 3:55:09 PM H:\PROJECTS\2789_CrossRoads_Phase 4\Roadway\Drawings\Sections\0903208-XSEC.CRL - 240.dgn

(CAUTION) THE LOCATION OF ALL UTILITIES AS SHOWN ARE APPROXIMATE. DUE TO RELOCATION'S PLANNED OR PRESENTLY UNDER CONSTRUCTION THERE ARE SOME UTILITIES THAT WILL BE RELOCATED AND NOT SHOWN ON THESE PLANS. THE CONTRACTOR SHALL BE RESPONSIBLE FOR ANY DAMAGE TO ALL UTILITIES.
 DEPTH & LOCATION OF EXISTING UTILITIES SHALL BE FIELD VERIFIED BY THE CONTRACTOR PRIOR TO CONSTRUCTION.

SEE DRAINAGE AREA MAP SHEETS FOR DRAINAGE SYMBOLOLOGY.

R/W & U/E PURCHASED UNDER JP 09032(05)

POB & ASSOCIATES, OKLAHOMA CITY, OK.
90% PLAN SUBMITTAL
 3/4/2024

AREA
 CUT FILL

VOLUME
 CUT FILL

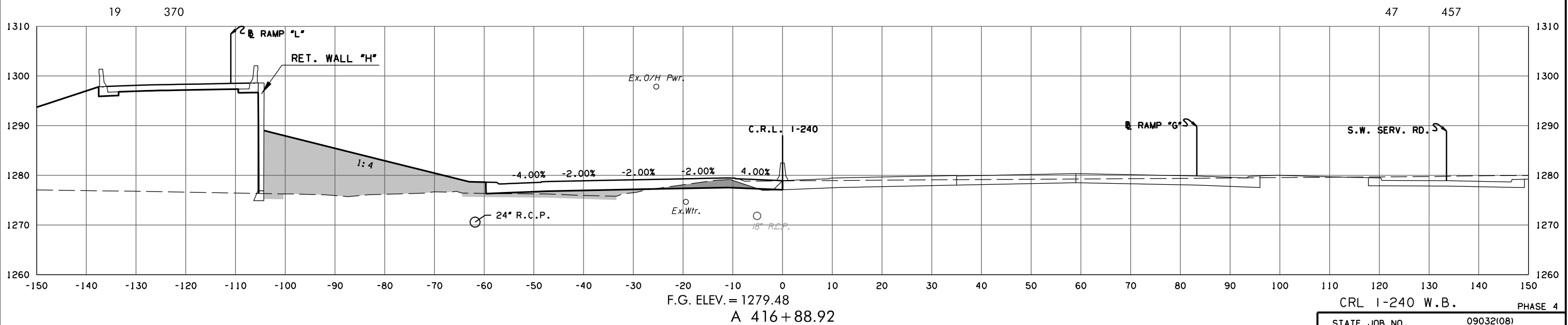
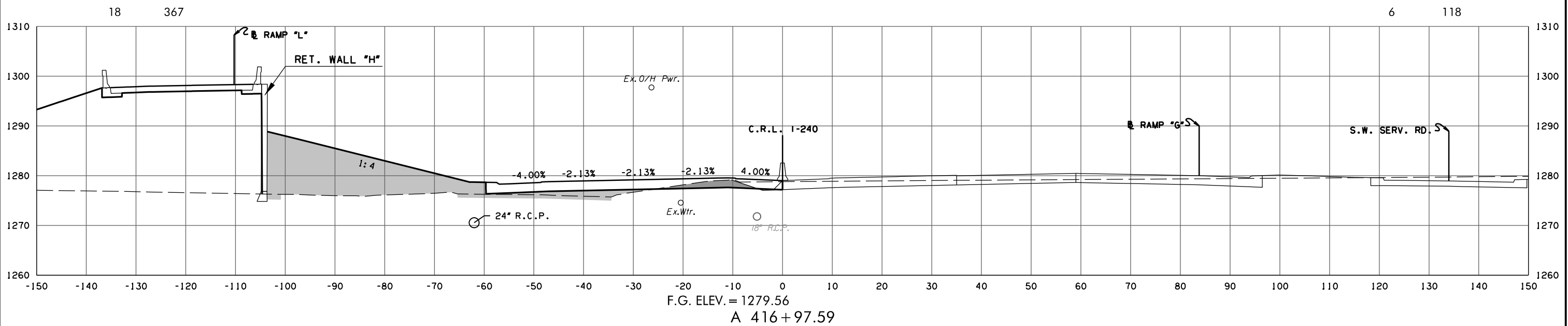

3/4/2024 3:55:19 PM H:\PROJECTS\2789_CrossRoads_Phase 4\Roadway\Drawings\Sections\0903208-XSEC.CRL.WB.I-240.dgn

CRL I-240 W.B. PHASE 4
 STATE JOB NO. 09032(08)
 OKLAHOMA COUNTY SHEET NO. X043

(CAUTION) THE LOCATION OF ALL UTILITIES AS SHOWN ARE APPROXIMATE. DUE TO RELOCATION'S PLANNED OR PRESENTLY UNDER CONSTRUCTION THERE ARE SOME UTILITIES THAT WILL BE RELOCATED AND NOT SHOWN ON THESE PLANS. THE CONTRACTOR SHALL BE RESPONSIBLE FOR ANY DAMAGE TO ALL UTILITIES. DEPTH & LOCATION OF EXISTING UTILITIES SHALL BE FIELD VERIFIED BY THE CONTRACTOR PRIOR TO CONSTRUCTION.

SEE DRAINAGE AREA MAP SHEETS FOR DRAINAGE SYMBOLOLOGY.

R/W & U/E PURCHASED UNDER JP 09032(05)

POB & ASSOCIATES, OKLAHOMA CITY, OK.
90% PLAN SUBMITTAL
 3/4/2024

AREA
 CUT FILL

VOLUME
 CUT FILL

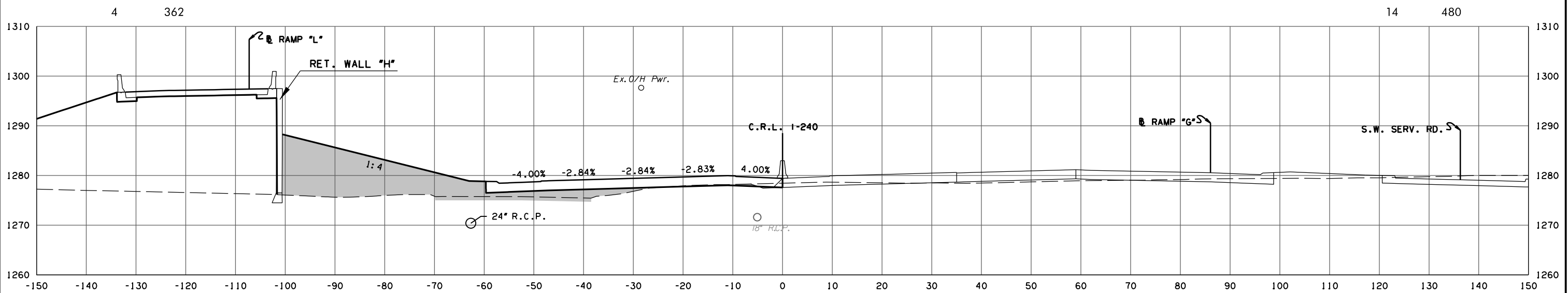

F.G. ELEV. = 1279.96
 A 417+35.64
 BEGIN FULL SUPER ROTATION

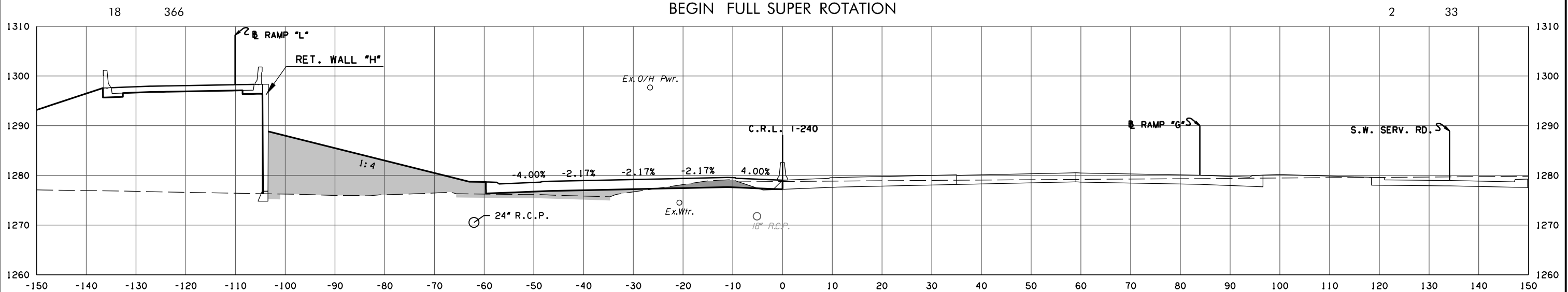

F.G. ELEV. = 1279.58
 A 417+00.00

CRL 1-240 W.B. PHASE 4
 STATE JOB NO. 09032(08)
 OKLAHOMA COUNTY SHEET NO. X044

3/4/2024 3:55:21 PM H:\PROJECTS\2789_CrossRoads_Phase 4\Roadway\Drawings\Sections\0903208-XSEC.CRL.WB.1-240.dgn

(CAUTION) THE LOCATION OF ALL UTILITIES AS SHOWN ARE APPROXIMATE. DUE TO RELOCATION'S PLANNED OR PRESENTLY UNDER CONSTRUCTION THERE ARE SOME UTILITIES THAT WILL BE RELOCATED AND NOT SHOWN ON THESE PLANS. THE CONTRACTOR SHALL BE RESPONSIBLE FOR ANY DAMAGE TO ALL UTILITIES.
 DEPTH & LOCATION OF EXISTING UTILITIES SHALL BE FIELD VERIFIED BY THE CONTRACTOR PRIOR TO CONSTRUCTION.

SEE DRAINAGE AREA MAP SHEETS FOR DRAINAGE SYMBOLOLOGY.

R/W & U/E PURCHASED UNDER JP 09032(05)

POB & ASSOCIATES, OKLAHOMA CITY, OK.
90% PLAN SUBMITTAL
 3/4/2024

AREA
 CUT FILL

VOLUME
 CUT FILL

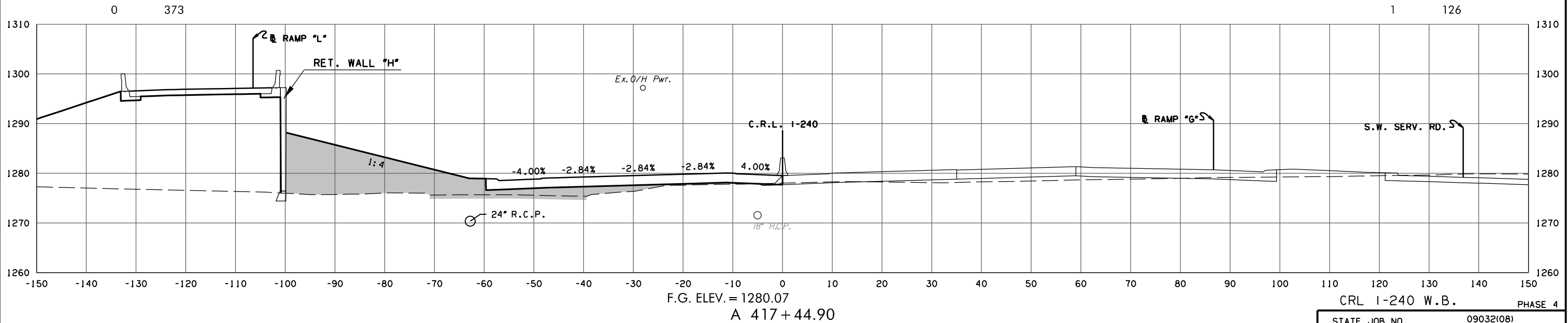
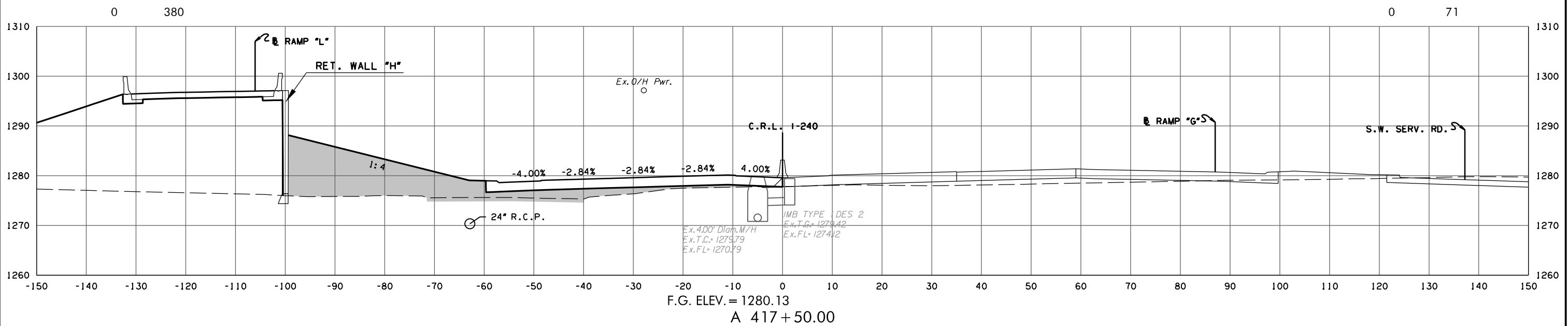

CRL 1-240 W.B. PHASE 4
 STATE JOB NO. 09032(08)
 OKLAHOMA COUNTY SHEET NO. X045

3/4/2024 3:55:22 PM H:\PROJECTS\2789_CrossRoads_Phase 4\Roadway\Drawings\Sections\0903208-XSEC-CRL-WB-1-240.dgn

(CAUTION) THE LOCATION OF ALL UTILITIES AS SHOWN ARE APPROXIMATE. DUE TO RELOCATION'S PLANNED OR PRESENTLY UNDER CONSTRUCTION THERE ARE SOME UTILITIES THAT WILL BE RELOCATED AND NOT SHOWN ON THESE PLANS. THE CONTRACTOR SHALL BE RESPONSIBLE FOR ANY DAMAGE TO ALL UTILITIES.
 DEPTH & LOCATION OF EXISTING UTILITIES SHALL BE FIELD VERIFIED BY THE CONTRACTOR PRIOR TO CONSTRUCTION.

SEE DRAINAGE AREA MAP SHEETS FOR DRAINAGE SYMBOLOLOGY.

R/W & U/E PURCHASED UNDER JP 09032(05)

POB & ASSOCIATES, OKLAHOMA CITY, OK.
90% PLAN SUBMITTAL
 3/4/2024

AREA
 CUT FILL

VOLUME
 CUT FILL

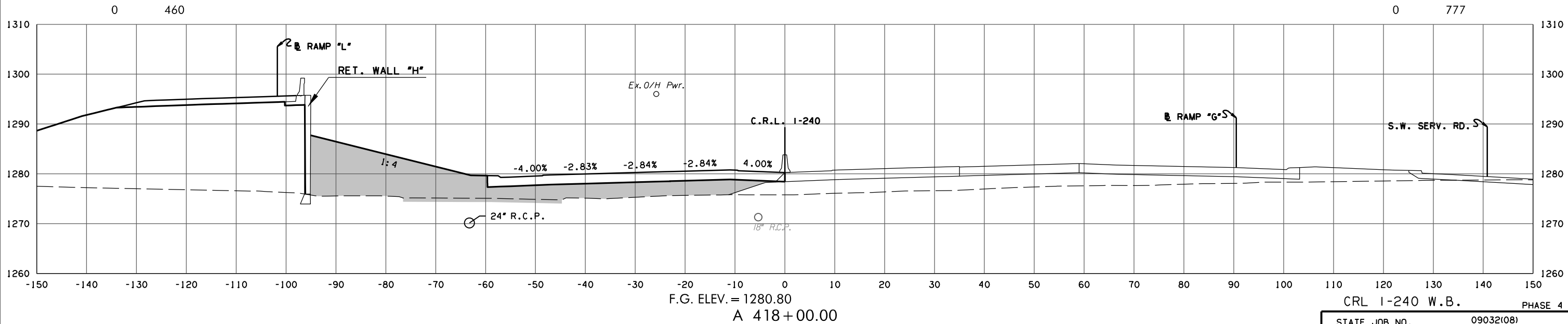
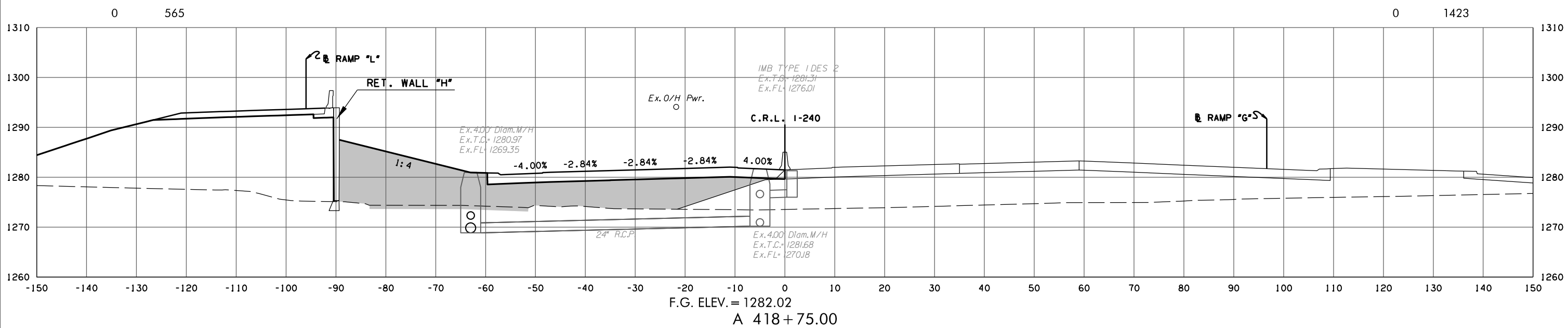

CRL 1-240 W.B. PHASE 4
 STATE JOB NO. 09032(08)
 OKLAHOMA COUNTY SHEET NO. X046

3/4/2024 3:55:24 PM H:\PROJECTS\2789_CrossRoads_Phase 4\Roadway\Drawings\Sections\0903208-XSEC-CRL-WB-1-240.dgn

(CAUTION) THE LOCATION OF ALL UTILITIES AS SHOWN ARE APPROXIMATE. DUE TO RELOCATION'S PLANNED OR PRESENTLY UNDER CONSTRUCTION THERE ARE SOME UTILITIES THAT WILL BE RELOCATED AND NOT SHOWN ON THESE PLANS. THE CONTRACTOR SHALL BE RESPONSIBLE FOR ANY DAMAGE TO ALL UTILITIES.
 DEPTH & LOCATION OF EXISTING UTILITIES SHALL BE FIELD VERIFIED BY THE CONTRACTOR PRIOR TO CONSTRUCTION.

SEE DRAINAGE AREA MAP SHEETS FOR DRAINAGE SYMBOLOLOGY.

R/W & U/E PURCHASED UNDER JP 09032(05)

POB & ASSOCIATES, OKLAHOMA CITY, OK.
90% PLAN SUBMITTAL
 3/4/2024

AREA
 CUT FILL

VOLUME
 CUT FILL

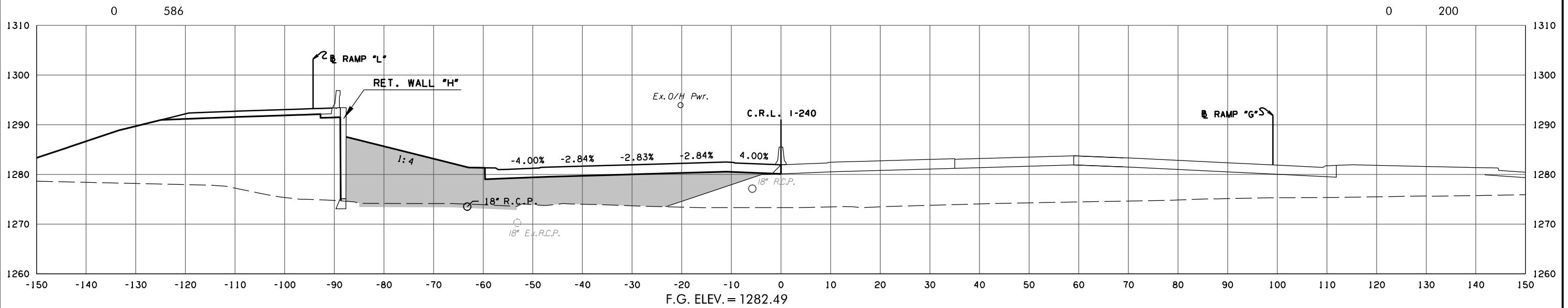

F.G. ELEV. = 1282.49
 A 419+00.00

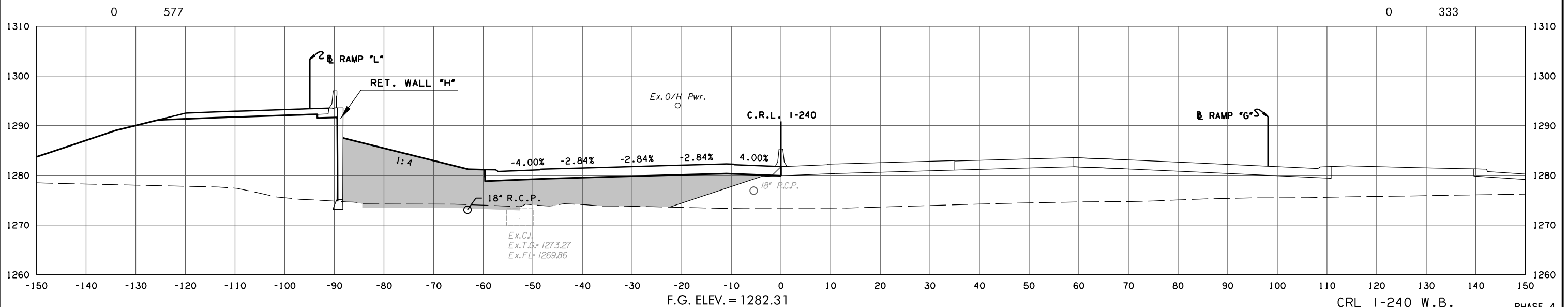

F.G. ELEV. = 1282.31
 A 418+90.73

CRL 1-240 W.B. PHASE 4
 STATE JOB NO. 09032(08)
 OKLAHOMA COUNTY SHEET NO. X047



3/4/2024 3:55:26 PM
 H:\PROJECTS\2789_CrossRoads_Phase 4\Roadway\Drawings\Sections\0903208-XSEC-CRL-WB-1-240.dgn

(CAUTION) THE LOCATION OF ALL UTILITIES AS SHOWN ARE APPROXIMATE. DUE TO RELOCATION'S PLANNED OR PRESENTLY UNDER CONSTRUCTION THERE ARE SOME UTILITIES THAT WILL BE RELOCATED AND NOT SHOWN ON THESE PLANS. THE CONTRACTOR SHALL BE RESPONSIBLE FOR ANY DAMAGE TO ALL UTILITIES.
 DEPTH & LOCATION OF EXISTING UTILITIES SHALL BE FIELD VERIFIED BY THE CONTRACTOR PRIOR TO CONSTRUCTION.

SEE DRAINAGE AREA MAP SHEETS FOR DRAINAGE SYMBOLOLOGY.

R/W & U/E PURCHASED UNDER JP 09032(05)

POB & ASSOCIATES, OKLAHOMA CITY, OK.
90% PLAN SUBMITTAL
 3/4/2024

AREA
 CUT  FILL 

VOLUME
 CUT FILL

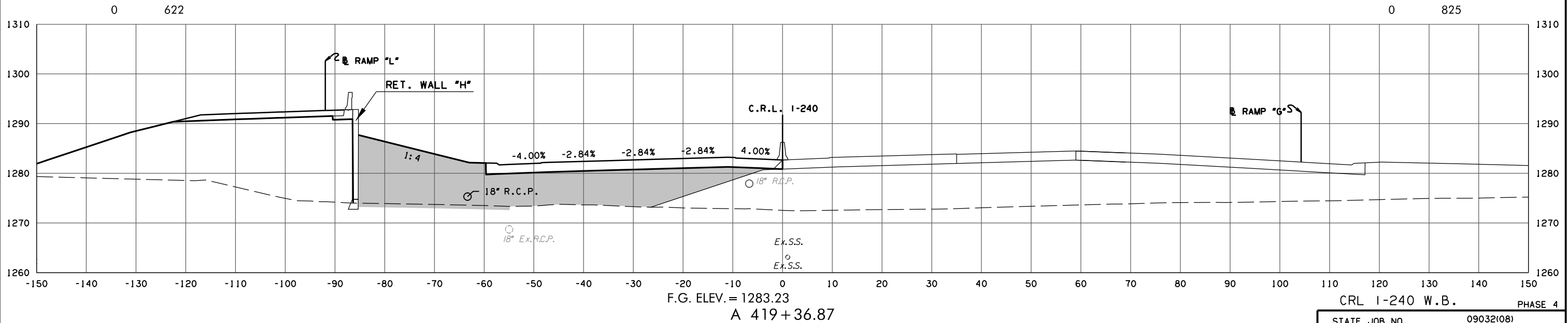
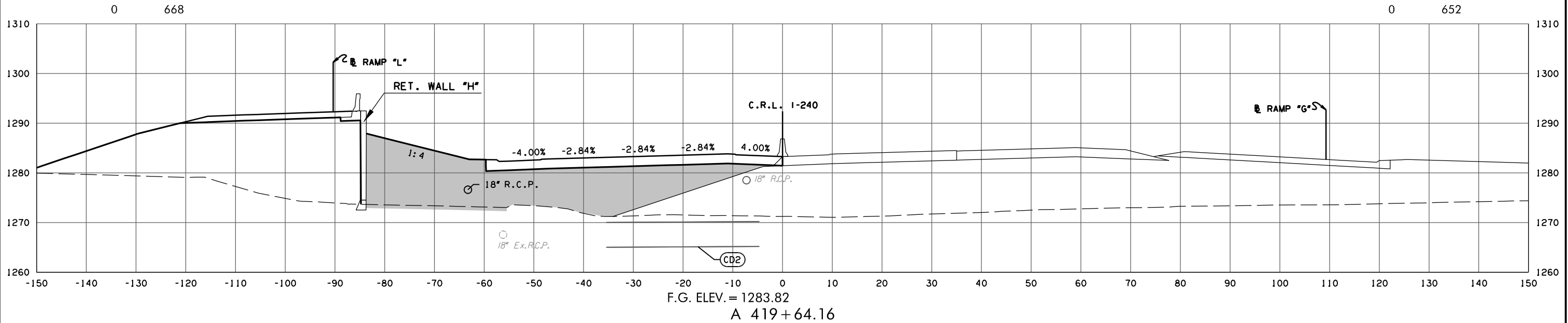

CRL 1-240 W.B. PHASE 4
 STATE JOB NO. 09032(08)
 OKLAHOMA COUNTY SHEET NO. X048

3/4/2024 3:55:27 PM
 H:\PROJECTS\2789_CrossRoads_Phase 4\Roadway\Drawings\Sections\0903208-XSEC.CRL.WB.1-240.dgn

(CAUTION) THE LOCATION OF ALL UTILITIES AS SHOWN ARE APPROXIMATE. DUE TO RELOCATION'S PLANNED OR PRESENTLY UNDER CONSTRUCTION THERE ARE SOME UTILITIES THAT WILL BE RELOCATED AND NOT SHOWN ON THESE PLANS. THE CONTRACTOR SHALL BE RESPONSIBLE FOR ANY DAMAGE TO ALL UTILITIES.
 DEPTH & LOCATION OF EXISTING UTILITIES SHALL BE FIELD VERIFIED BY THE CONTRACTOR PRIOR TO CONSTRUCTION.

SEE DRAINAGE AREA MAP SHEETS FOR DRAINAGE SYMBOLOLOGY.

R/W & U/E PURCHASED UNDER JP 09032(05)

POB & ASSOCIATES, OKLAHOMA CITY, OK.
90% PLAN SUBMITTAL
 3/4/2024

AREA
 CUT FILL

VOLUME
 CUT FILL

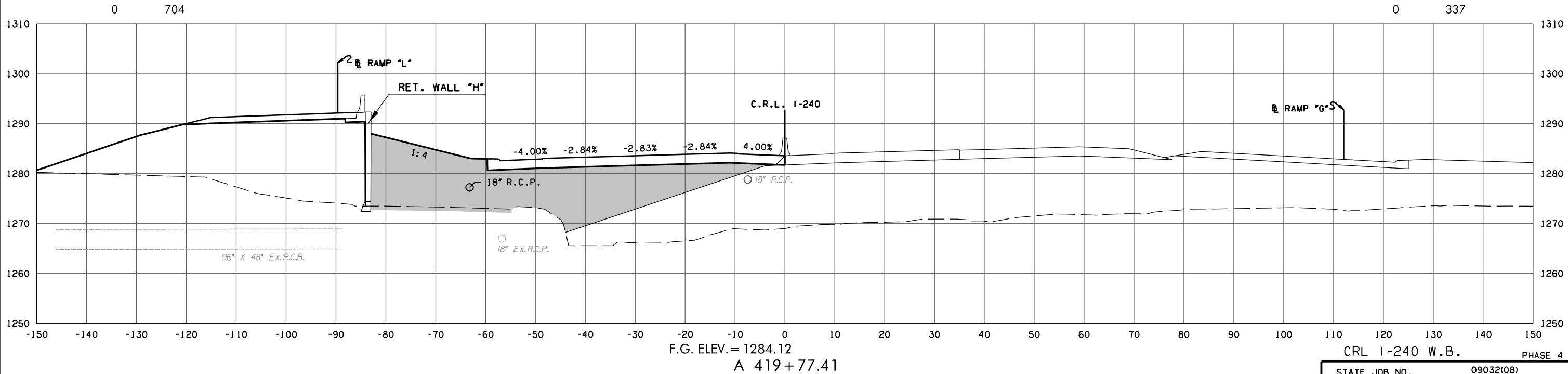
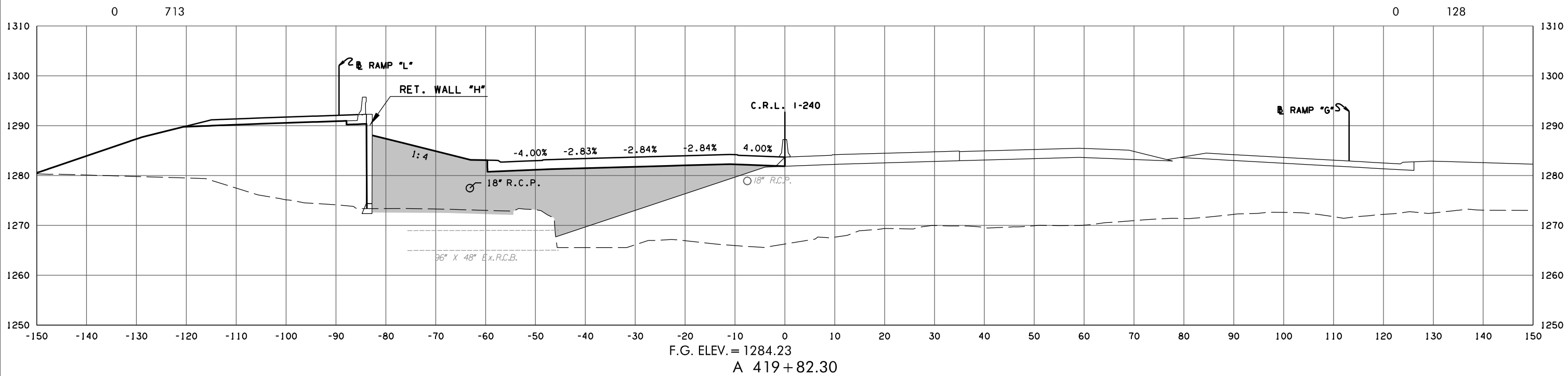

CRL 1-240 W.B. PHASE 4
 STATE JOB NO. 09032(08)
 OKLAHOMA COUNTY SHEET NO. X049

3/4/2024 3:55:29 PM H:\PROJECTS\2789_CrossRoads_Phase 4\Roadway\Drawings\Sections\0903208-XSEC.CRL.WB.1-240.dgn

(CAUTION) THE LOCATION OF ALL UTILITIES AS SHOWN ARE APPROXIMATE. DUE TO RELOCATION'S PLANNED OR PRESENTLY UNDER CONSTRUCTION THERE ARE SOME UTILITIES THAT WILL BE RELOCATED AND NOT SHOWN ON THESE PLANS. THE CONTRACTOR SHALL BE RESPONSIBLE FOR ANY DAMAGE TO ALL UTILITIES.
 DEPTH & LOCATION OF EXISTING UTILITIES SHALL BE FIELD VERIFIED BY THE CONTRACTOR PRIOR TO CONSTRUCTION.

SEE DRAINAGE AREA MAP SHEETS FOR DRAINAGE SYMBOLOLOGY.

R/W & U/E PURCHASED UNDER JP 09032(05)

POB & ASSOCIATES, OKLAHOMA CITY, OK.
90% PLAN SUBMITTAL
 3/4/2024

AREA
 CUT FILL

VOLUME
 CUT FILL

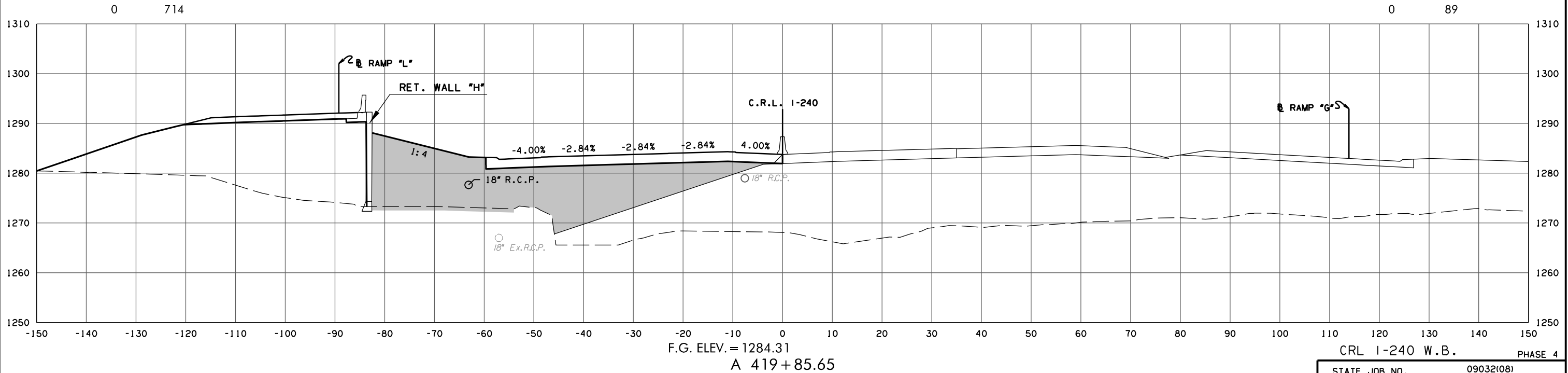
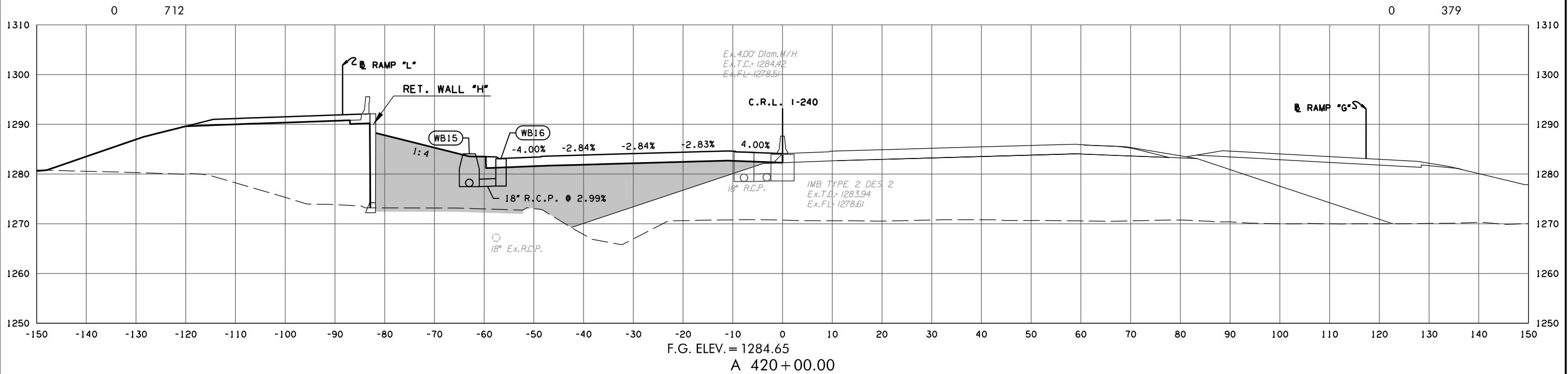

CRL 1-240 W.B. PHASE 4
 STATE JOB NO. 09032(08)
 OKLAHOMA COUNTY SHEET NO. X050

3/4/2024 3:55:31 PM H:\PROJECTS\2789_CrossRoads_Phase 4\Roadway\Drawings\Sections\0903208-XSEC-CRL-WB-1-240.dgn

(CAUTION) THE LOCATION OF ALL UTILITIES AS SHOWN ARE APPROXIMATE. DUE TO RELOCATION'S PLANNED OR PRESENTLY UNDER CONSTRUCTION THERE ARE SOME UTILITIES THAT WILL BE RELOCATED AND NOT SHOWN ON THESE PLANS. THE CONTRACTOR SHALL BE RESPONSIBLE FOR ANY DAMAGE TO ALL UTILITIES.
 DEPTH & LOCATION OF EXISTING UTILITIES SHALL BE FIELD VERIFIED BY THE CONTRACTOR PRIOR TO CONSTRUCTION.

SEE DRAINAGE AREA MAP SHEETS FOR DRAINAGE SYMBOLOLOGY.

R/W & U/E PURCHASED UNDER JP 09032(05)

POB & ASSOCIATES, OKLAHOMA CITY, OK.
90% PLAN SUBMITTAL
 3/4/2024

AREA
 CUT FILL

VOLUME
 CUT FILL

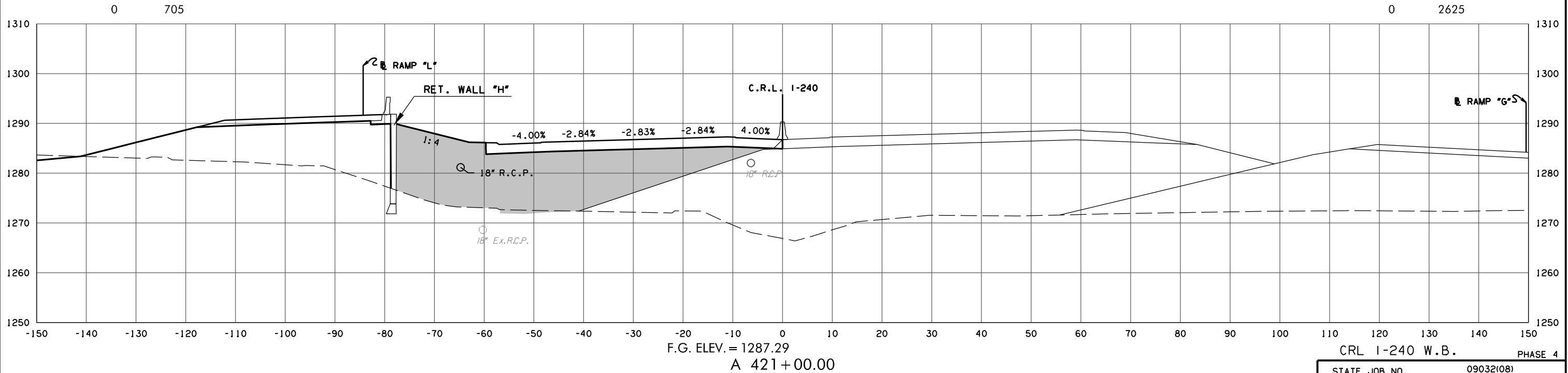
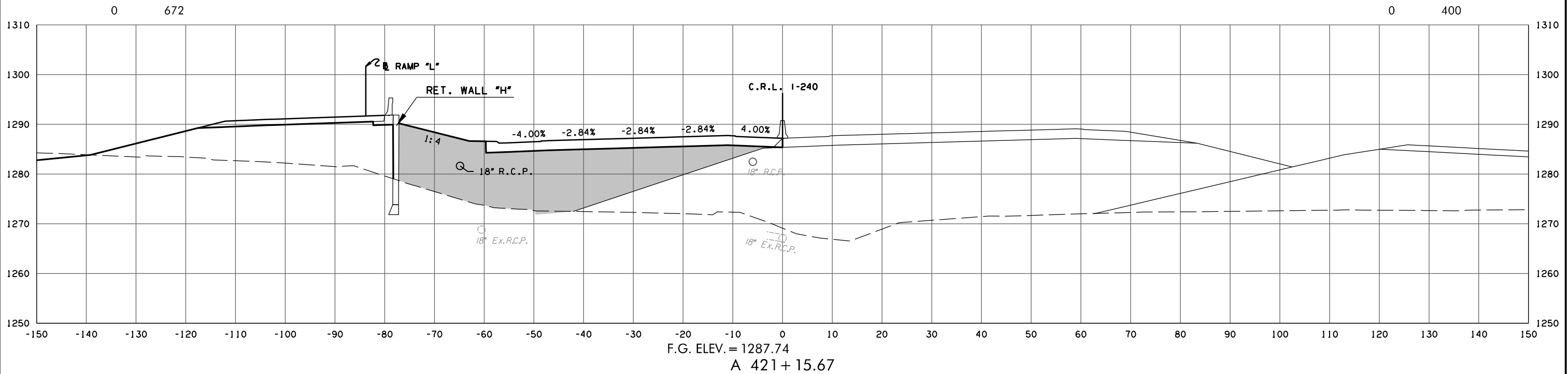

CRL 1-240 W.B. PHASE 4
 STATE JOB NO. 09032(08)
 OKLAHOMA COUNTY SHEET NO. X051

3/4/2024 3:55:33 PM H:\PROJECTS\2789_CrossRoads_Phase 4\Roadway\Drawings\Sections\0903208-XSEC.CRL.WB.1-240.dgn

(CAUTION) THE LOCATION OF ALL UTILITIES AS SHOWN ARE APPROXIMATE. DUE TO RELOCATION'S PLANNED OR PRESENTLY UNDER CONSTRUCTION THERE ARE SOME UTILITIES THAT WILL BE RELOCATED AND NOT SHOWN ON THESE PLANS. THE CONTRACTOR SHALL BE RESPONSIBLE FOR ANY DAMAGE TO ALL UTILITIES.
 DEPTH & LOCATION OF EXISTING UTILITIES SHALL BE FIELD VERIFIED BY THE CONTRACTOR PRIOR TO CONSTRUCTION.

SEE DRAINAGE AREA MAP SHEETS FOR DRAINAGE SYMBOLOLOGY.

R/W & U/E PURCHASED UNDER JP 09032(05)

POB & ASSOCIATES, OKLAHOMA CITY, OK.
90% PLAN SUBMITTAL
 3/4/2024

AREA
 CUT FILL

VOLUME
 CUT FILL

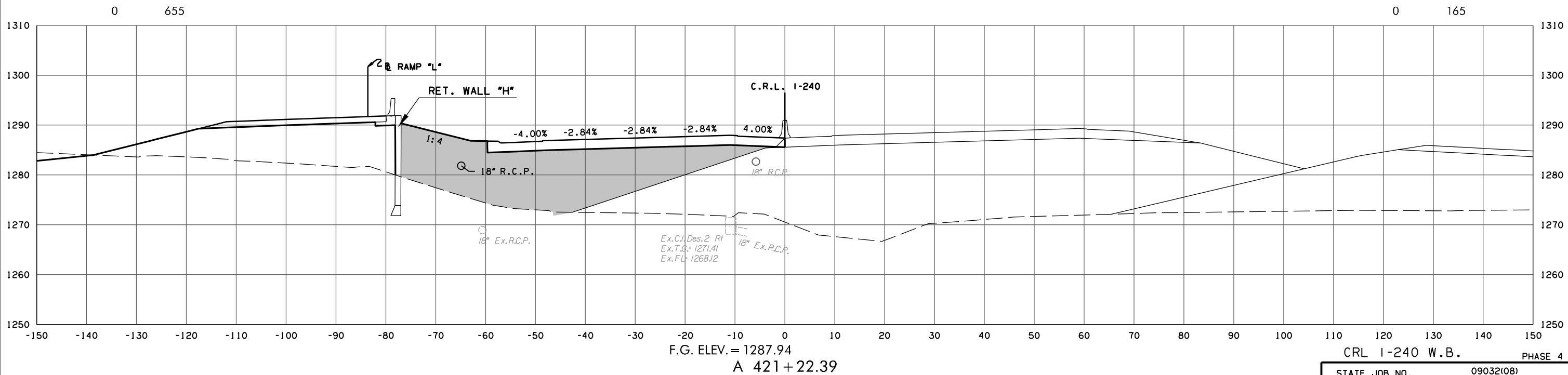
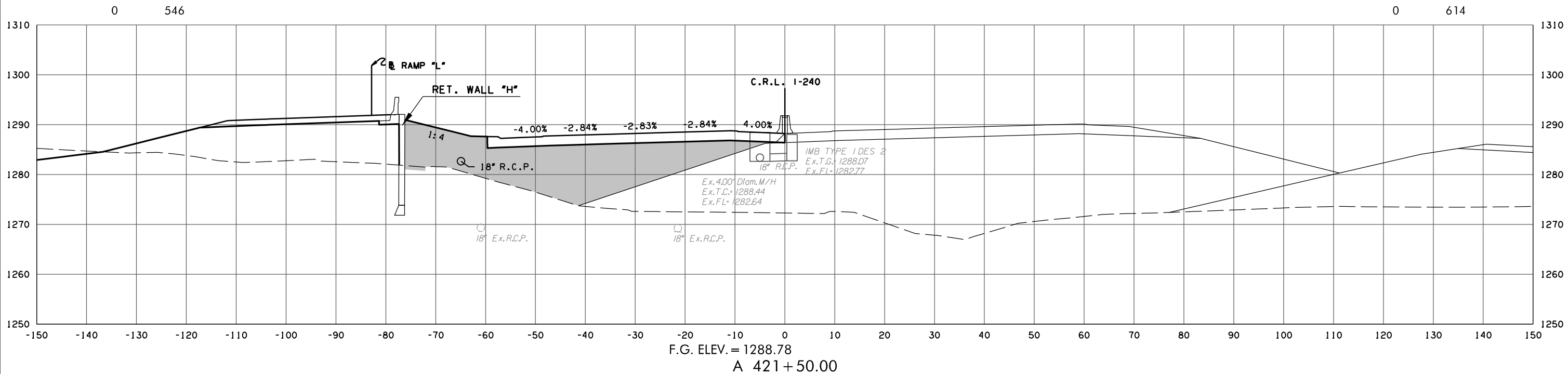

CRL 1-240 W.B. PHASE 4

STATE JOB NO. 09032(08)

OKLAHOMA COUNTY SHEET NO. X052

3/4/2024 3:55:34 PM
 H:\PROJECTS\2789_CrossRoads_Phase 4\Roadway\Drawings\Sections\0903208-XSEC.CRL.WB.1-240.dgn

(CAUTION) THE LOCATION OF ALL UTILITIES AS SHOWN ARE APPROXIMATE. DUE TO RELOCATION'S PLANNED OR PRESENTLY UNDER CONSTRUCTION THERE ARE SOME UTILITIES THAT WILL BE RELOCATED AND NOT SHOWN ON THESE PLANS. THE CONTRACTOR SHALL BE RESPONSIBLE FOR ANY DAMAGE TO ALL UTILITIES.

DEPTH & LOCATION OF EXISTING UTILITIES SHALL BE FIELD VERIFIED BY THE CONTRACTOR PRIOR TO CONSTRUCTION.

SEE DRAINAGE AREA MAP SHEETS FOR DRAINAGE SYMBOLOLOGY.

R/W & U/E PURCHASED UNDER JP 09032(05)

POB & ASSOCIATES, OKLAHOMA CITY, OK.

**90% PLAN
SUBMITTAL**

3/4/2024

AREA

CUT	FILL
0	817

VOLUME

CUT	FILL
0	1179

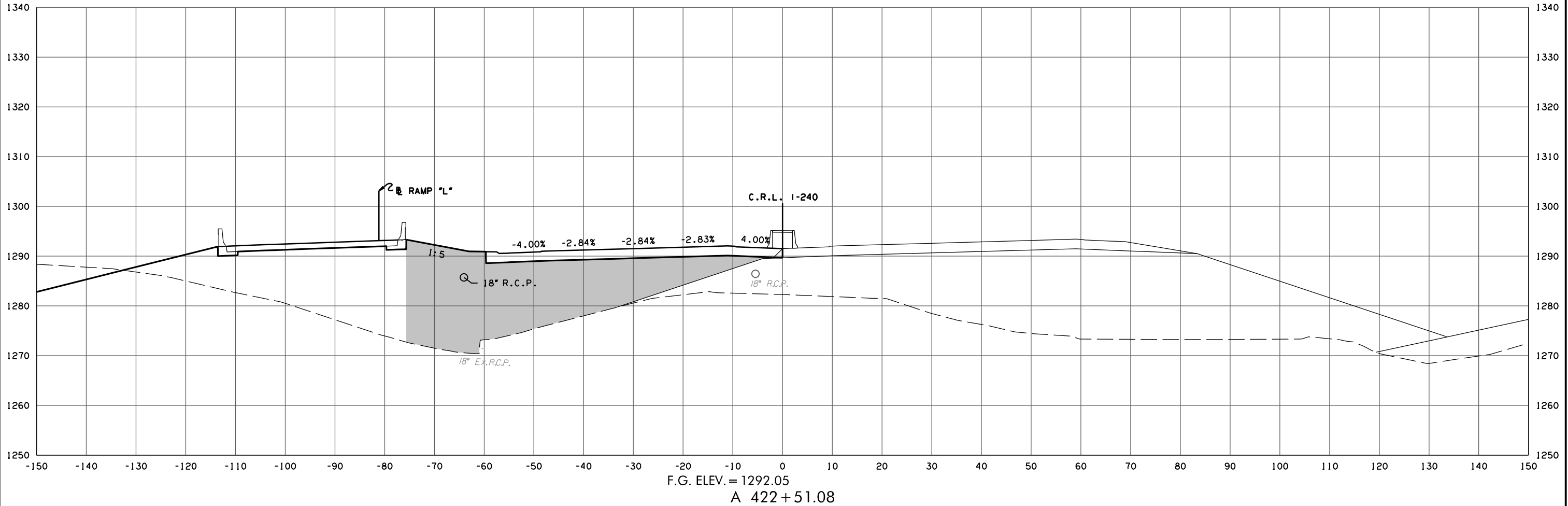

0 430

0 903

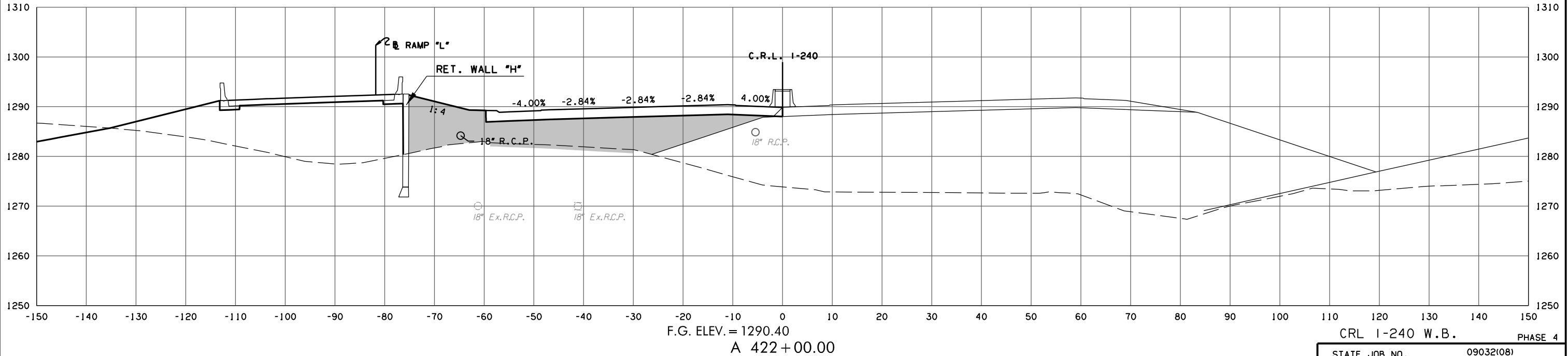

CRL 1-240 W.B. PHASE 4

STATE JOB NO. 09032(08)
OKLAHOMA COUNTY SHEET NO. X053

3/4/2024 3:55:36 PM H:\PROJECTS\2789_CrossRoads_Phase 4\Roadway\Drawings\Sections\0903208-XSEC.CRL-WB-1-240.dgn

(CAUTION) THE LOCATION OF ALL UTILITIES AS SHOWN ARE APPROXIMATE. DUE TO RELOCATION'S PLANNED OR PRESENTLY UNDER CONSTRUCTION THERE ARE SOME UTILITIES THAT WILL BE RELOCATED AND NOT SHOWN ON THESE PLANS. THE CONTRACTOR SHALL BE RESPONSIBLE FOR ANY DAMAGE TO ALL UTILITIES. DEPTH & LOCATION OF EXISTING UTILITIES SHALL BE FIELD VERIFIED BY THE CONTRACTOR PRIOR TO CONSTRUCTION.

SEE DRAINAGE AREA MAP SHEETS FOR DRAINAGE SYMBOLOLOGY.

R/W & U/E PURCHASED UNDER JP 09032(05)

POB & ASSOCIATES, OKLAHOMA CITY, OK.
90% PLAN
SUBMITTAL
 3/4/2024

AREA
 CUT FILL

VOLUME
 CUT FILL

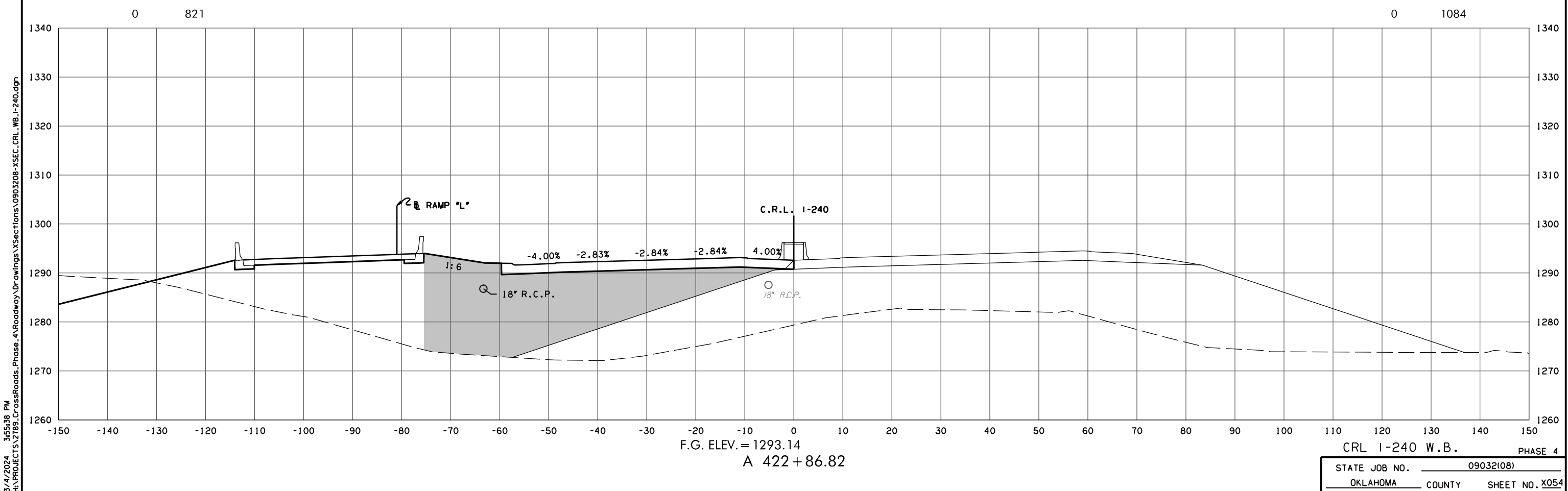

3/4/2024 3:55:38 PM
 H:\PROJECTS\2789_CrossRoads_Phase 4\Roadway\Drawings\Sections\0903208-XSEC-CRL-WB-I-240.dgn

F.G. ELEV. = 1293.14
 A 422 + 86.82

CRL 1-240 W.B. PHASE 4
 STATE JOB NO. 09032(08)
 OKLAHOMA COUNTY SHEET NO. X054

(CAUTION) THE LOCATION OF ALL UTILITIES AS SHOWN ARE APPROXIMATE. DUE TO RELOCATION'S PLANNED OR PRESENTLY UNDER CONSTRUCTION THERE ARE SOME UTILITIES THAT WILL BE RELOCATED AND NOT SHOWN ON THESE PLANS. THE CONTRACTOR SHALL BE RESPONSIBLE FOR ANY DAMAGE TO ALL UTILITIES.
 DEPTH & LOCATION OF EXISTING UTILITIES SHALL BE FIELD VERIFIED BY THE CONTRACTOR PRIOR TO CONSTRUCTION.

SEE DRAINAGE AREA MAP SHEETS FOR DRAINAGE SYMBOLOLOGY.

R/W & U/E PURCHASED UNDER JP 09032(05)

POB & ASSOCIATES, OKLAHOMA CITY, OK.
90% PLAN
SUBMITTAL
 3/4/2024

AREA
 CUT FILL

VOLUME
 CUT FILL

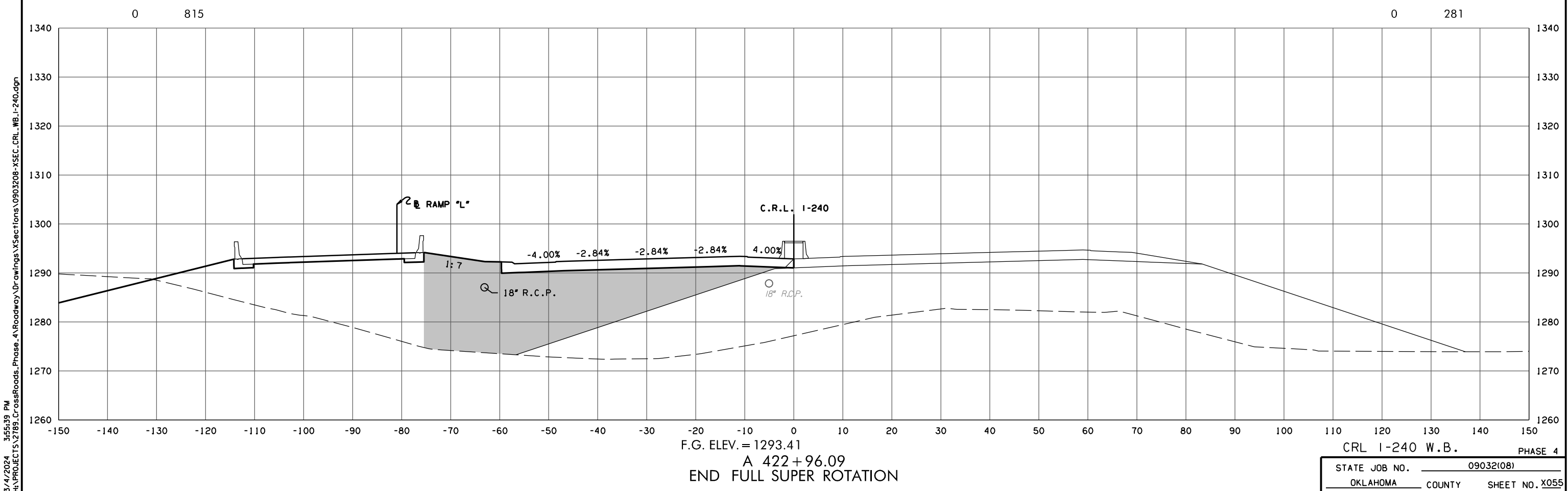

3/4/2024 3:55:39 PM H:\PROJECTS\2789_CrossRoads_Phase 4\Roadway\Drawings\Sections\0903208-XSEC-CRL-WB-I-240.dgn

F.G. ELEV. = 1293.41
 A 422 + 96.09
 END FULL SUPER ROTATION

CRL 1-240 W.B. PHASE 4
 STATE JOB NO. 09032(08)
 OKLAHOMA COUNTY SHEET NO. X055

(CAUTION) THE LOCATION OF ALL UTILITIES AS SHOWN ARE APPROXIMATE. DUE TO RELOCATION'S PLANNED OR PRESENTLY UNDER CONSTRUCTION THERE ARE SOME UTILITIES THAT WILL BE RELOCATED AND NOT SHOWN ON THESE PLANS. THE CONTRACTOR SHALL BE RESPONSIBLE FOR ANY DAMAGE TO ALL UTILITIES.
 DEPTH & LOCATION OF EXISTING UTILITIES SHALL BE FIELD VERIFIED BY THE CONTRACTOR PRIOR TO CONSTRUCTION.

SEE DRAINAGE AREA MAP SHEETS FOR DRAINAGE SYMBOLOLOGY.

R/W & U/E PURCHASED UNDER JP 09032(05)

POB & ASSOCIATES, OKLAHOMA CITY, OK.
90% PLAN
SUBMITTAL
 3/4/2024

AREA
 CUT FILL

VOLUME
 CUT FILL

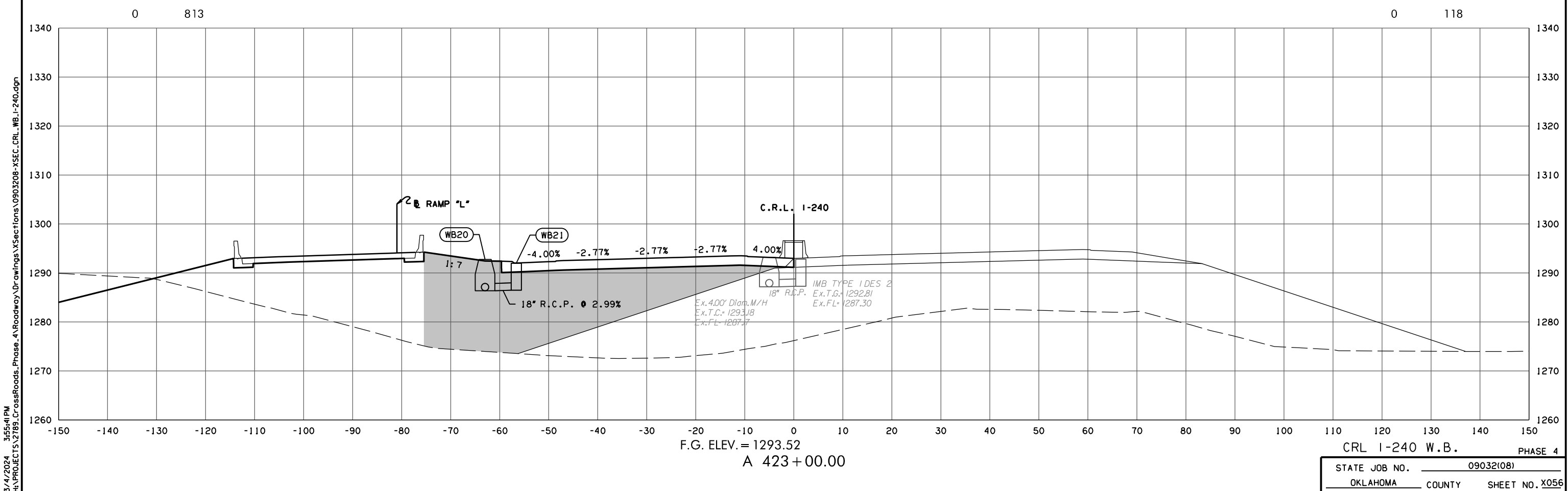

3/4/2024 3:55:41 PM H:\PROJECTS\2789_CrossRoads_Phase 4\Roadway\Drawings\Sections\0903208-XSEC-CRL-WB-1-240.dgn

F.G. ELEV. = 1293.52
 A 423 + 00.00

CRL 1-240 W.B. PHASE 4
 STATE JOB NO. 09032(08)
 OKLAHOMA COUNTY SHEET NO. X056

(CAUTION) THE LOCATION OF ALL UTILITIES AS SHOWN ARE APPROXIMATE. DUE TO RELOCATION'S PLANNED OR PRESENTLY UNDER CONSTRUCTION THERE ARE SOME UTILITIES THAT WILL BE RELOCATED AND NOT SHOWN ON THESE PLANS. THE CONTRACTOR SHALL BE RESPONSIBLE FOR ANY DAMAGE TO ALL UTILITIES.
 DEPTH & LOCATION OF EXISTING UTILITIES SHALL BE FIELD VERIFIED BY THE CONTRACTOR PRIOR TO CONSTRUCTION.

SEE DRAINAGE AREA MAP SHEETS FOR DRAINAGE SYMBOLOLOGY.

R/W & U/E PURCHASED UNDER JP 09032(05)

POB & ASSOCIATES, OKLAHOMA CITY, OK.
90% PLAN
SUBMITTAL
 3/4/2024

AREA
 CUT FILL

VOLUME
 CUT FILL

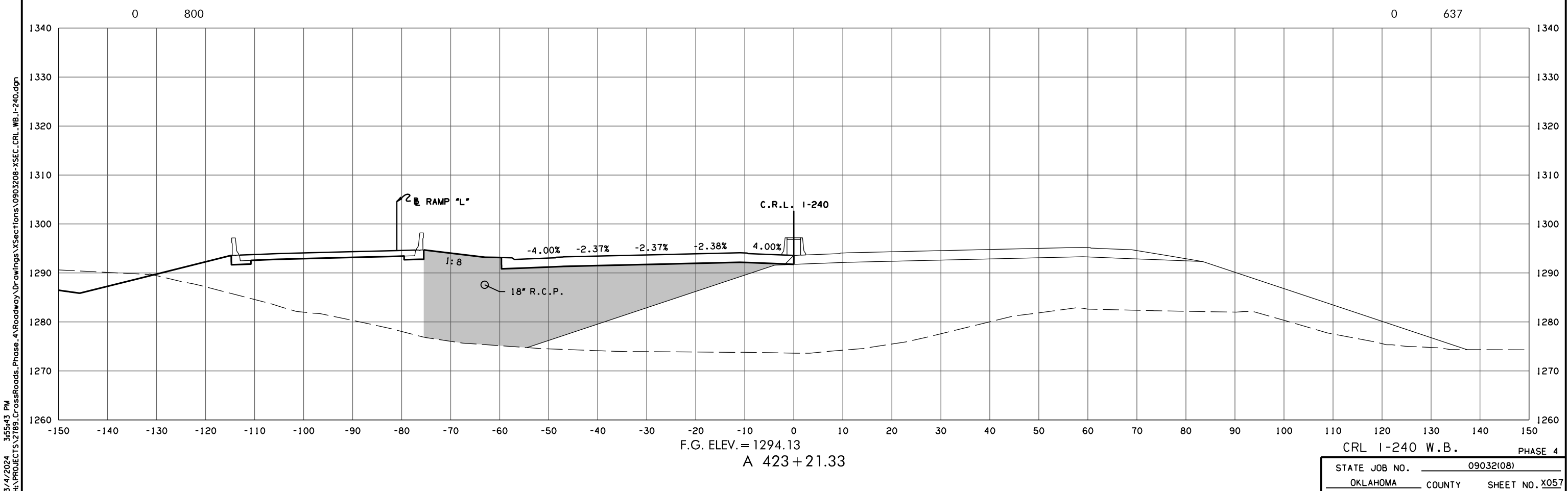

3/4/2024 3:55:43 PM
 H:\PROJECTS\2789_CrossRoads_Phase 4\Roadway\Drawings\Sections\0903208-XSEC_CRL_WB_1-240.dgn

(CAUTION) THE LOCATION OF ALL UTILITIES AS SHOWN ARE APPROXIMATE. DUE TO RELOCATION'S PLANNED OR PRESENTLY UNDER CONSTRUCTION THERE ARE SOME UTILITIES THAT WILL BE RELOCATED AND NOT SHOWN ON THESE PLANS. THE CONTRACTOR SHALL BE RESPONSIBLE FOR ANY DAMAGE TO ALL UTILITIES.
 DEPTH & LOCATION OF EXISTING UTILITIES SHALL BE FIELD VERIFIED BY THE CONTRACTOR PRIOR TO CONSTRUCTION.

SEE DRAINAGE AREA MAP SHEETS FOR DRAINAGE SYMBOLOLOGY.

R/W & U/E PURCHASED UNDER JP 09032(05)

POB & ASSOCIATES, OKLAHOMA CITY, OK.
90% PLAN
SUBMITTAL
 3/4/2024

AREA
 CUT FILL

VOLUME
 CUT FILL

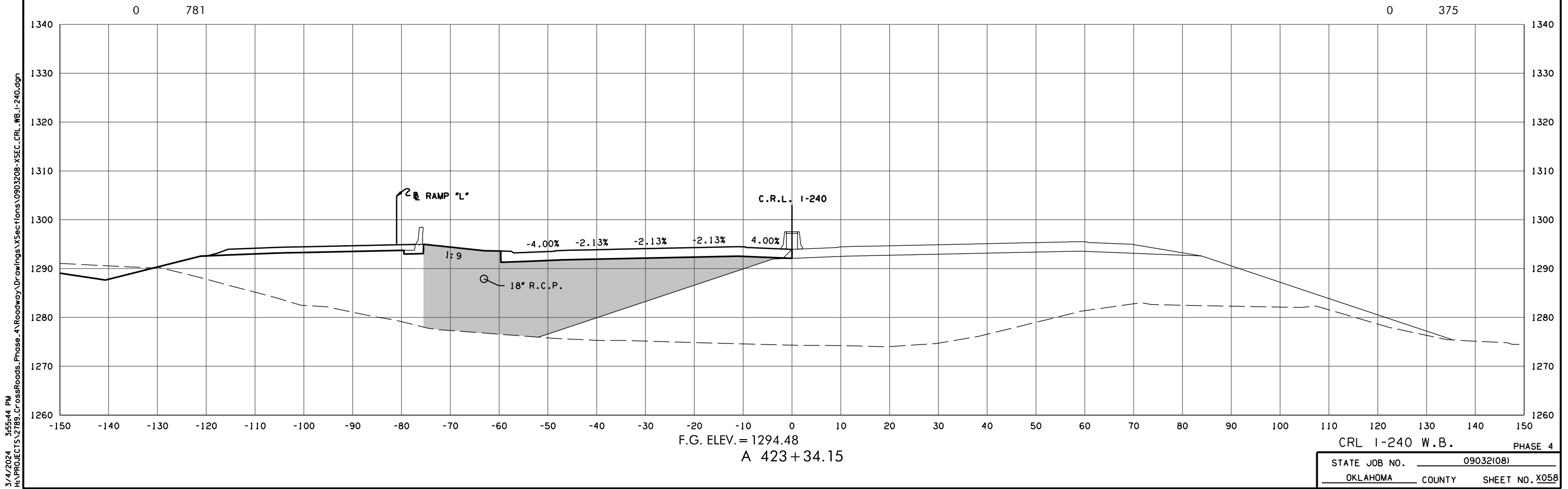

(CAUTION) THE LOCATION OF ALL UTILITIES AS SHOWN ARE APPROXIMATE. DUE TO RELOCATION'S PLANNED OR PRESENTLY UNDER CONSTRUCTION THERE ARE SOME UTILITIES THAT WILL BE RELOCATED AND NOT SHOWN ON THESE PLANS. THE CONTRACTOR SHALL BE RESPONSIBLE FOR ANY DAMAGE TO ALL UTILITIES.
 DEPTH & LOCATION OF EXISTING UTILITIES SHALL BE FIELD VERIFIED BY THE CONTRACTOR PRIOR TO CONSTRUCTION.

SEE DRAINAGE AREA MAP SHEETS FOR DRAINAGE SYMBOLOLOGY.

R/W & U/E PURCHASED UNDER JP 09032(05)

POB & ASSOCIATES, OKLAHOMA CITY, OK.
90% PLAN
SUBMITTAL
 3/4/2024

AREA
 CUT FILL

VOLUME
 CUT FILL

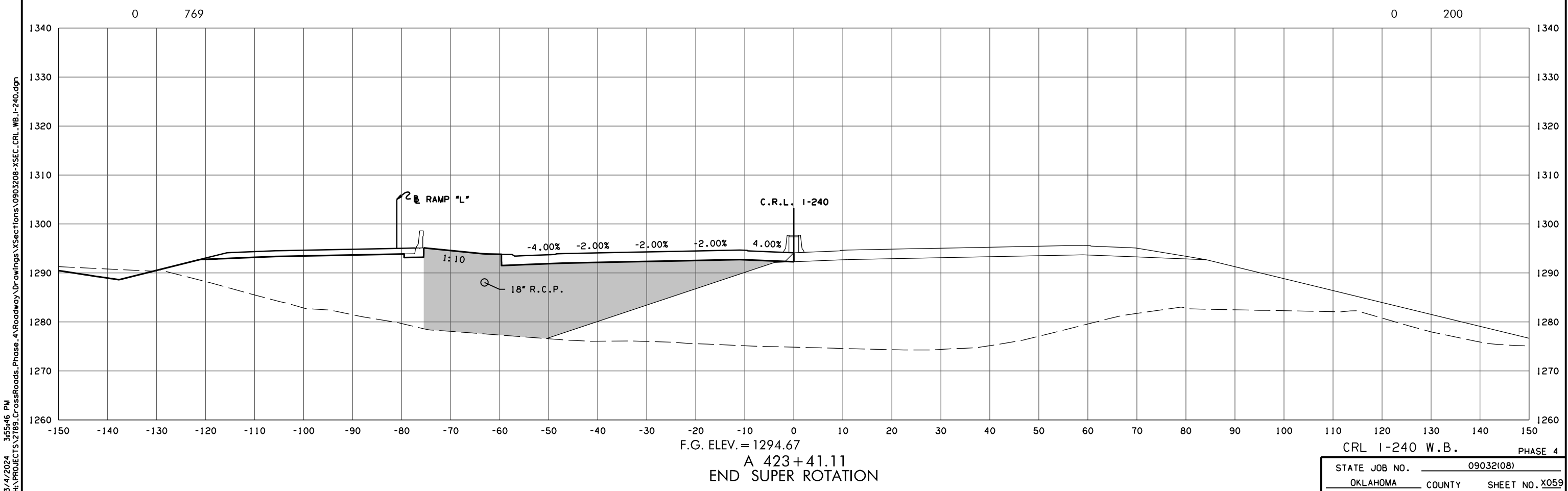

3/4/2024 3:55:46 PM
 H:\PROJECTS\2789_CrossRoads_Phase 4\Roadway\Drawings\Sections\0903208-XSEC_CRL_WB_1-240.dgn

CRL 1-240 W.B. PHASE 4
 STATE JOB NO. 09032(08)
 OKLAHOMA COUNTY SHEET NO. X059

(CAUTION) THE LOCATION OF ALL UTILITIES AS SHOWN ARE APPROXIMATE. DUE TO RELOCATION'S PLANNED OR PRESENTLY UNDER CONSTRUCTION THERE ARE SOME UTILITIES THAT WILL BE RELOCATED AND NOT SHOWN ON THESE PLANS. THE CONTRACTOR SHALL BE RESPONSIBLE FOR ANY DAMAGE TO ALL UTILITIES.
 DEPTH & LOCATION OF EXISTING UTILITIES SHALL BE FIELD VERIFIED BY THE CONTRACTOR PRIOR TO CONSTRUCTION.

SEE DRAINAGE AREA MAP SHEETS FOR DRAINAGE SYMBOLOLOGY.

R/W & U/E PURCHASED UNDER JP 09032(05)

POB & ASSOCIATES, OKLAHOMA CITY, OK.
90% PLAN SUBMITTAL
 3/4/2024

AREA
 CUT FILL

VOLUME
 CUT FILL

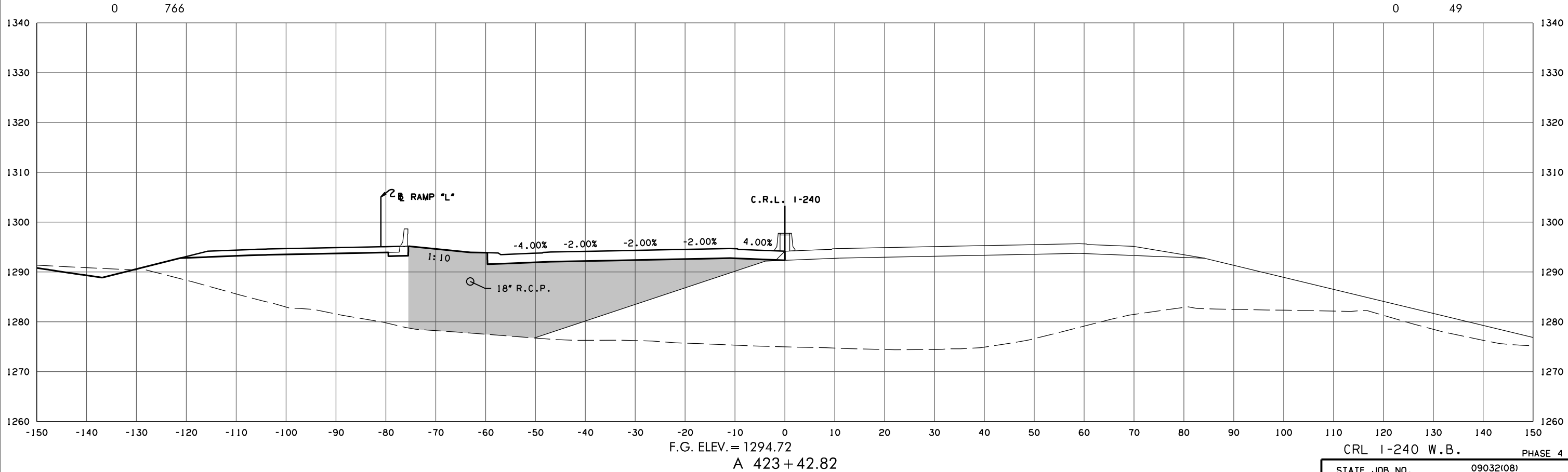
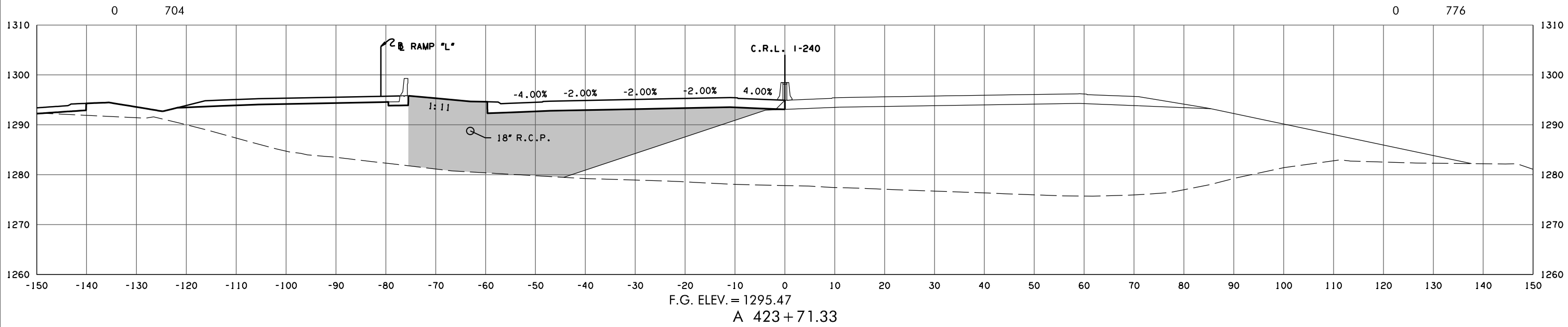

CRL 1-240 W.B. PHASE 4
 STATE JOB NO. 09032(08)
 OKLAHOMA COUNTY SHEET NO. X060

3/4/2024 3:55:48 PM
 H:\PROJECTS\2789_CrossRoads_Phase 4\Roadway\Drawings\Sections\0903208-XSEC-CRL-WB-1-240.dgn

(CAUTION) THE LOCATION OF ALL UTILITIES AS SHOWN ARE APPROXIMATE. DUE TO RELOCATION'S PLANNED OR PRESENTLY UNDER CONSTRUCTION THERE ARE SOME UTILITIES THAT WILL BE RELOCATED AND NOT SHOWN ON THESE PLANS. THE CONTRACTOR SHALL BE RESPONSIBLE FOR ANY DAMAGE TO ALL UTILITIES.
 DEPTH & LOCATION OF EXISTING UTILITIES SHALL BE FIELD VERIFIED BY THE CONTRACTOR PRIOR TO CONSTRUCTION.

SEE DRAINAGE AREA MAP SHEETS FOR DRAINAGE SYMBOLOLOGY.

R/W & U/E PURCHASED UNDER JP 09032(05)

POB & ASSOCIATES, OKLAHOMA CITY, OK.

90% PLAN SUBMITTAL

3/4/2024

AREA
 CUT FILL

0 320

VOLUME
 CUT FILL

0 68

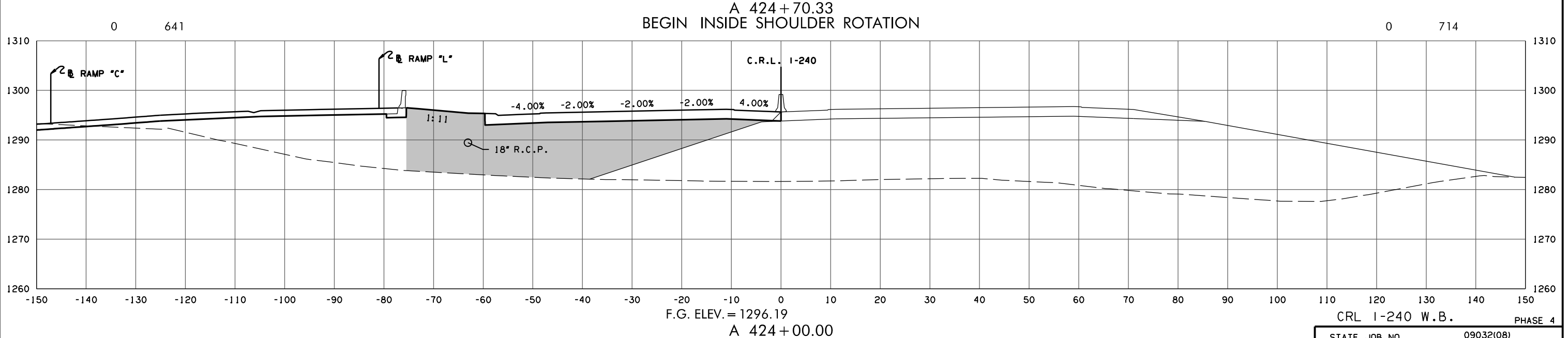
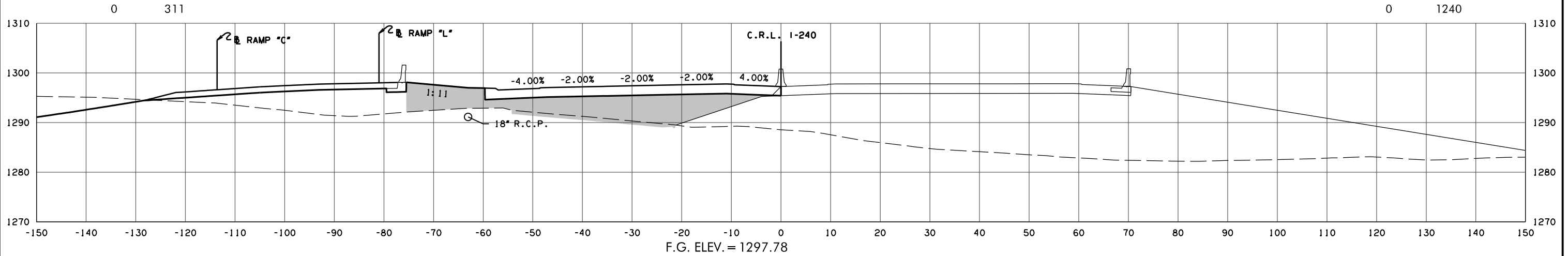
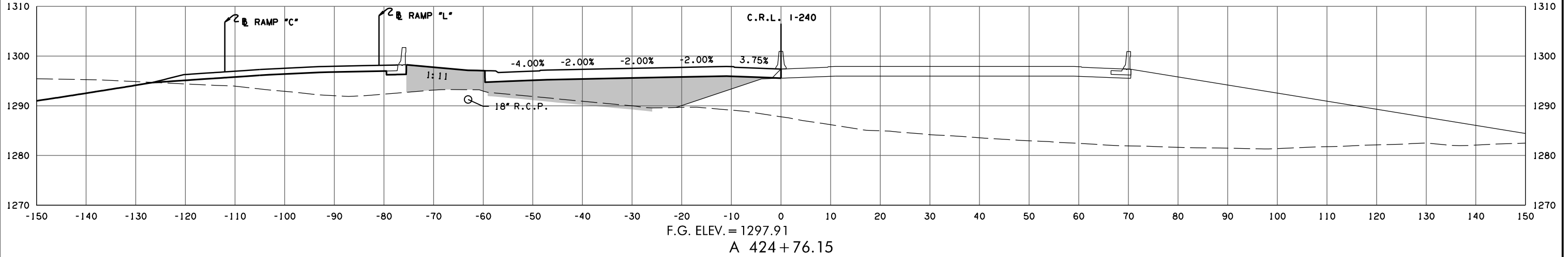

CRL 1-240 W.B. PHASE 4

STATE JOB NO. 09032(08)
 OKLAHOMA COUNTY SHEET NO. X061

3/4/2024 3:55:50 PM
 H:\PROJECTS\2789_CrossRoads_Phase 4\Roadway\Drawings\Sections\0903208-XSEC-CRL-WB-1-240.dgn

(CAUTION) THE LOCATION OF ALL UTILITIES AS SHOWN ARE APPROXIMATE. DUE TO RELOCATION'S PLANNED OR PRESENTLY UNDER CONSTRUCTION THERE ARE SOME UTILITIES THAT WILL BE RELOCATED AND NOT SHOWN ON THESE PLANS. THE CONTRACTOR SHALL BE RESPONSIBLE FOR ANY DAMAGE TO ALL UTILITIES.
 DEPTH & LOCATION OF EXISTING UTILITIES SHALL BE FIELD VERIFIED BY THE CONTRACTOR PRIOR TO CONSTRUCTION.

SEE DRAINAGE AREA MAP SHEETS FOR DRAINAGE SYMBOLOLOGY.

R/W & U/E PURCHASED UNDER JP 09032(05)

POB & ASSOCIATES, OKLAHOMA CITY, OK.
90% PLAN SUBMITTAL
 3/4/2024

AREA
 CUT FILL

VOLUME
 CUT FILL

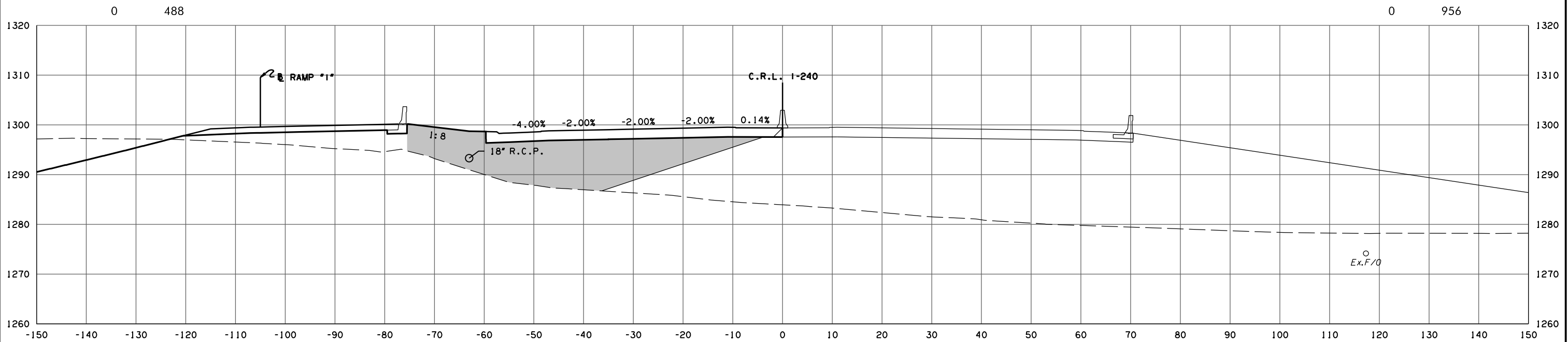

F.G. ELEV. = 1299.52

A 425+61.33

BEGIN OUTSIDE SHOULDER ROTATION

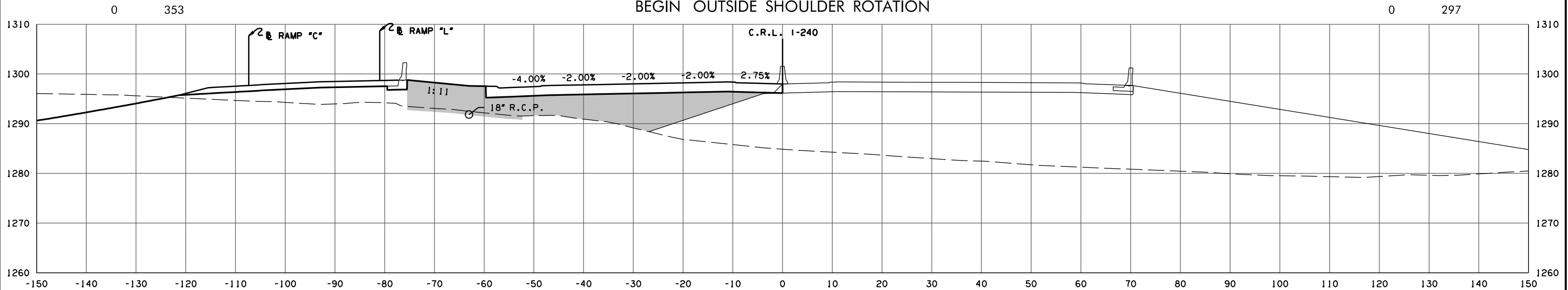

F.G. ELEV. = 1298.39

A 425+00.00

CRL 1-240 W.B. PHASE 4

STATE JOB NO. 09032(08)
 OKLAHOMA COUNTY SHEET NO. X062

3/4/2024 3:55:51 PM H:\PROJECTS\2789_CrossRoads_Phase 4\Roadway\Drawings\Sections\0903208-XSEC-CRL-WB-1-240.dgn

(CAUTION) THE LOCATION OF ALL UTILITIES AS SHOWN ARE APPROXIMATE. DUE TO RELOCATION'S PLANNED OR PRESENTLY UNDER CONSTRUCTION THERE ARE SOME UTILITIES THAT WILL BE RELOCATED AND NOT SHOWN ON THESE PLANS. THE CONTRACTOR SHALL BE RESPONSIBLE FOR ANY DAMAGE TO ALL UTILITIES. DEPTH & LOCATION OF EXISTING UTILITIES SHALL BE FIELD VERIFIED BY THE CONTRACTOR PRIOR TO CONSTRUCTION.

SEE DRAINAGE AREA MAP SHEETS FOR DRAINAGE SYMBOLOLOGY.

R/W & U/E PURCHASED UNDER JP 09032(05)

POB & ASSOCIATES, OKLAHOMA CITY, OK.
90% PLAN SUBMITTAL
 3/4/2024

AREA
 CUT FILL

VOLUME
 CUT FILL

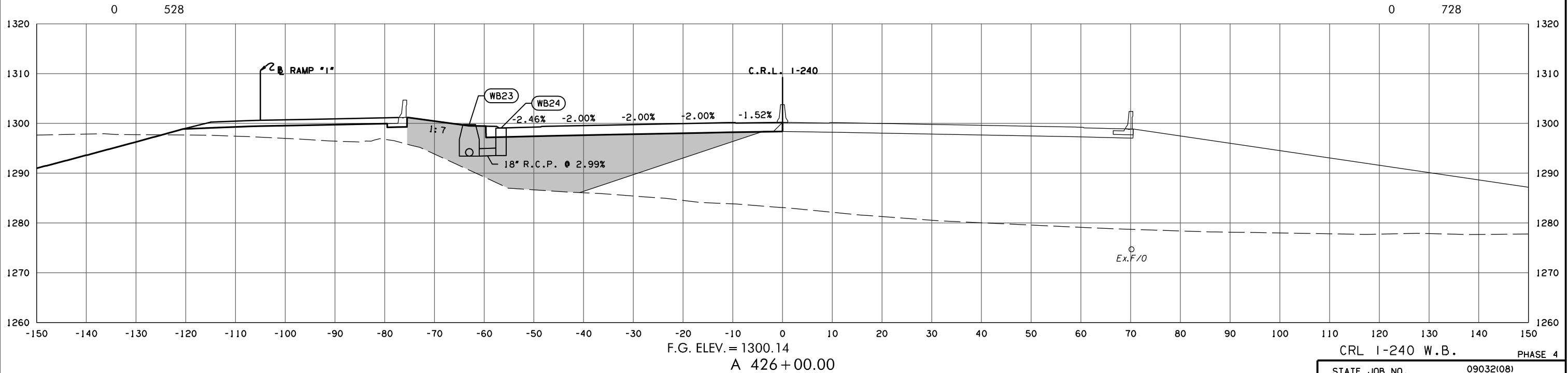
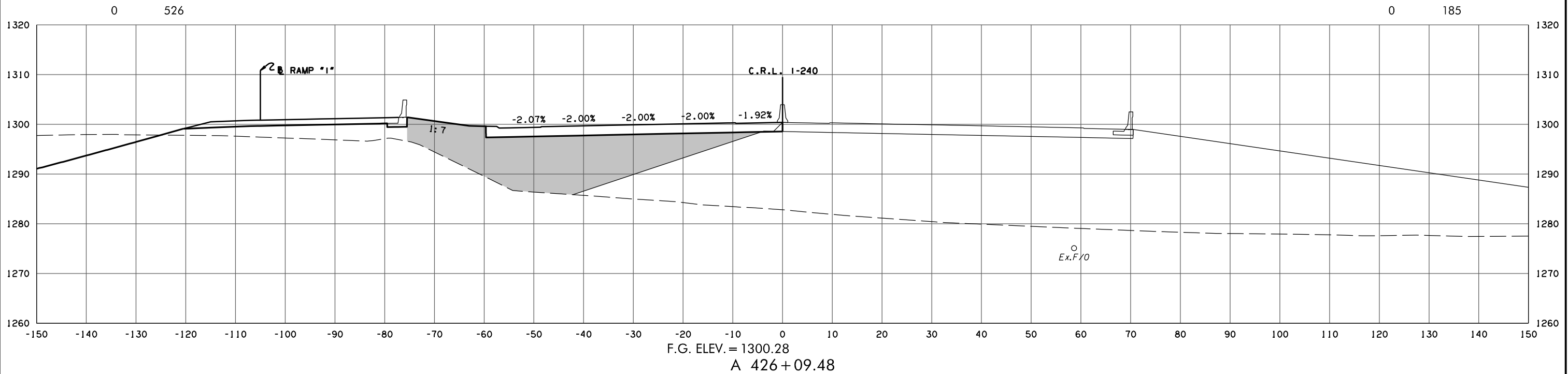

CRL 1-240 W.B. PHASE 4

STATE JOB NO. 09032(08)

OKLAHOMA COUNTY SHEET NO. X063

3/4/2024 3:55:53 PM
 H:\PROJECTS\2789_CrossRoads_Phase 4\Roadway\Drawings\Sections\0903208-XSEC.CRL.WB.1-240.dgn

(CAUTION) THE LOCATION OF ALL UTILITIES AS SHOWN ARE APPROXIMATE. DUE TO RELOCATION'S PLANNED OR PRESENTLY UNDER CONSTRUCTION THERE ARE SOME UTILITIES THAT WILL BE RELOCATED AND NOT SHOWN ON THESE PLANS. THE CONTRACTOR SHALL BE RESPONSIBLE FOR ANY DAMAGE TO ALL UTILITIES. DEPTH & LOCATION OF EXISTING UTILITIES SHALL BE FIELD VERIFIED BY THE CONTRACTOR PRIOR TO CONSTRUCTION.

SEE DRAINAGE AREA MAP SHEETS FOR DRAINAGE SYMBOLOLOGY.

R/W & U/E PURCHASED UNDER JP 09032(05)

POB & ASSOCIATES, OKLAHOMA CITY, OK
90% PLAN SUBMITTAL
 3/4/2024

AREA
 CUT FILL

VOLUME
 CUT FILL

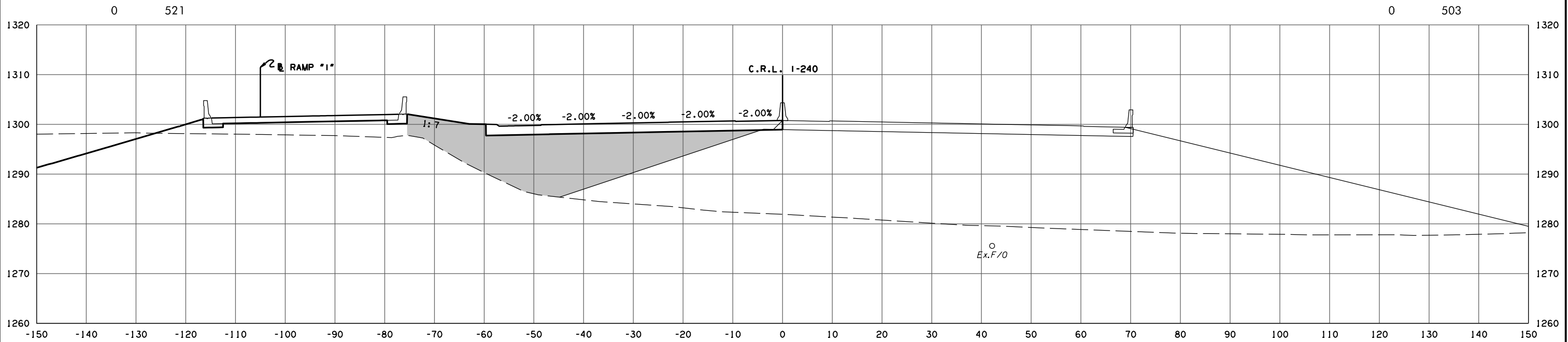

F.G. ELEV. = 1300.68
 A 426+37.33
 BEGIN APPROACH SLAB

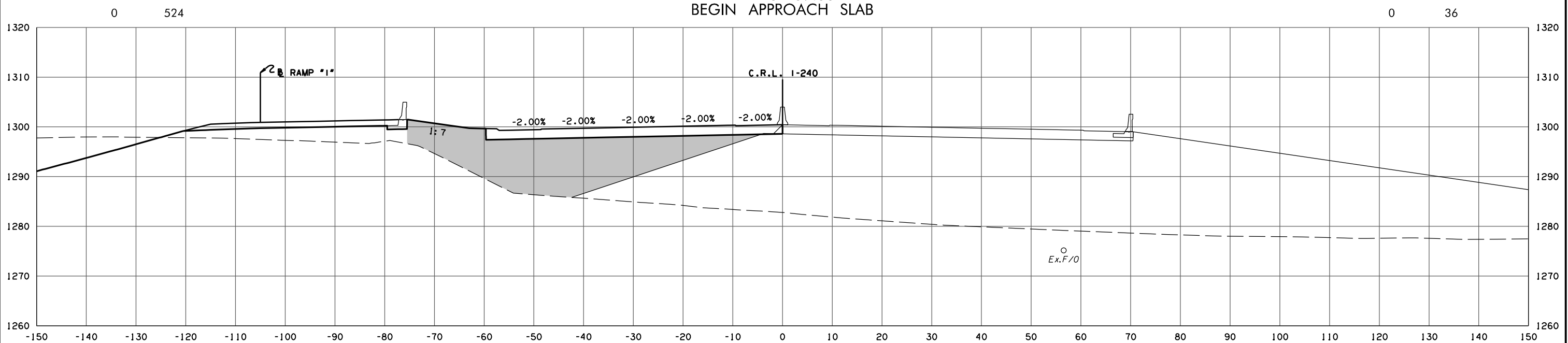

END OUTSIDE SHOULDER ROTATION END INSIDE SHOULDER ROTATION

CRL 1-240 W.B. PHASE 4
 STATE JOB NO. 09032(08)
 OKLAHOMA COUNTY SHEET NO. X064

3/4/2024 3:55:55 PM H:\PROJECTS\2789_CrossRoads_Phase 4\Roadway\Drawings\Sections\0903208-XSEC-CRL-WB-1-240.dgn

(CAUTION) THE LOCATION OF ALL UTILITIES AS SHOWN ARE APPROXIMATE. DUE TO RELOCATION'S PLANNED OR PRESENTLY UNDER CONSTRUCTION THERE ARE SOME UTILITIES THAT WILL BE RELOCATED AND NOT SHOWN ON THESE PLANS. THE CONTRACTOR SHALL BE RESPONSIBLE FOR ANY DAMAGE TO ALL UTILITIES.
 DEPTH & LOCATION OF EXISTING UTILITIES SHALL BE FIELD VERIFIED BY THE CONTRACTOR PRIOR TO CONSTRUCTION.

SEE DRAINAGE AREA MAP SHEETS FOR DRAINAGE SYMBOLOLOGY.

R/W & U/E PURCHASED UNDER JP 09032(05)

POB & ASSOCIATES, OKLAHOMA CITY, OK.
90% PLAN SUBMITTAL
 3/4/2024

AREA
 CUT FILL

VOLUME
 CUT FILL

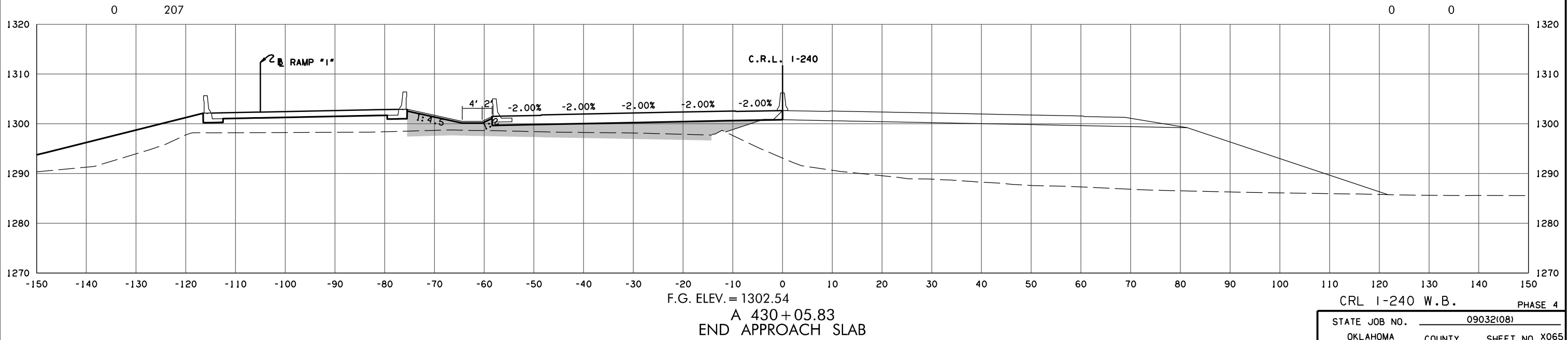
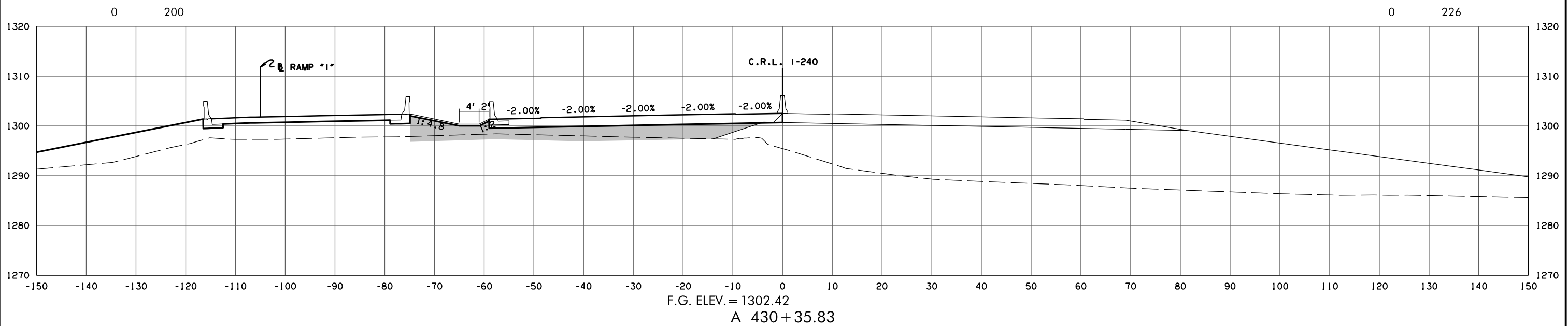

3/4/2024 3:55:56 PM H:\PROJECTS\2789_CrossRoads_Phase 4\Roadway\Drawings\Sections\0903208-XSEC.CRL.WB.I-240.dgn

CRL I-240 W.B. PHASE 4
 STATE JOB NO. 09032(08)
 OKLAHOMA COUNTY SHEET NO. X065

(CAUTION) THE LOCATION OF ALL UTILITIES AS SHOWN ARE APPROXIMATE. DUE TO RELOCATION'S PLANNED OR PRESENTLY UNDER CONSTRUCTION THERE ARE SOME UTILITIES THAT WILL BE RELOCATED AND NOT SHOWN ON THESE PLANS. THE CONTRACTOR SHALL BE RESPONSIBLE FOR ANY DAMAGE TO ALL UTILITIES.
 DEPTH & LOCATION OF EXISTING UTILITIES SHALL BE FIELD VERIFIED BY THE CONTRACTOR PRIOR TO CONSTRUCTION.

SEE DRAINAGE AREA MAP SHEETS FOR DRAINAGE SYMBOLOLOGY.

R/W & U/E PURCHASED UNDER JP 09032(05)

POB & ASSOCIATES, OKLAHOMA CITY, OK.
90% PLAN SUBMITTAL
 3/4/2024

AREA
 CUT FILL

VOLUME
 CUT FILL

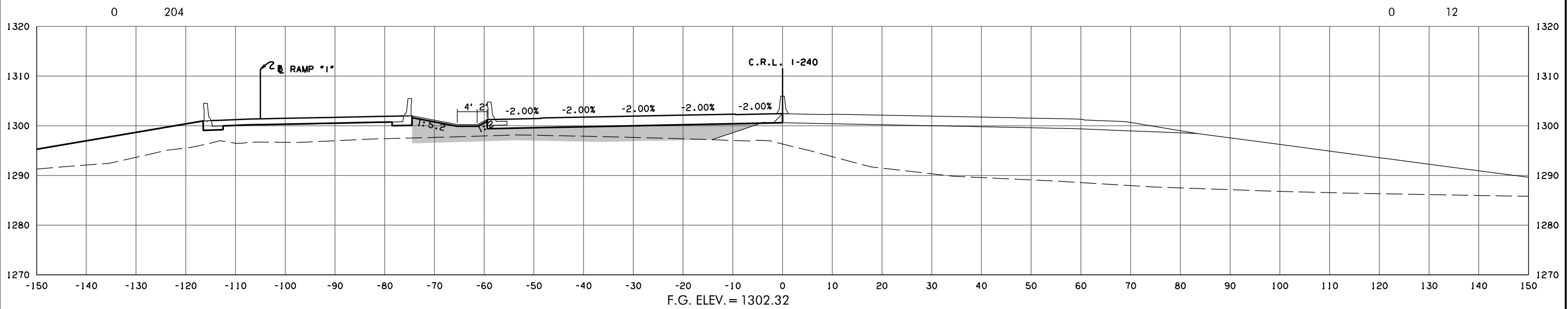

F.G. ELEV. = 1302.32
 A 430+55.83
 BEGIN OUTSIDE SHOULDER ROTATION BEGIN INSIDE SHOULDER ROTATION

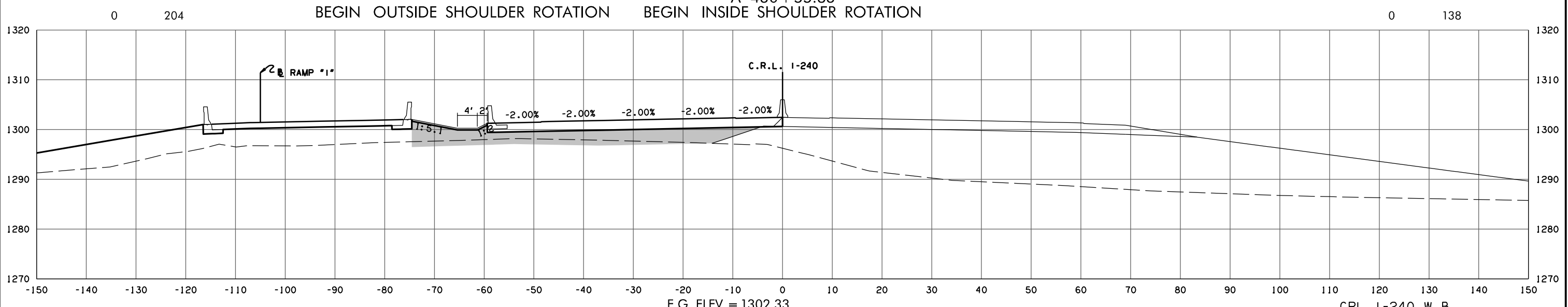

F.G. ELEV. = 1302.33
 A 430+54.22

CRL 1-240 W.B. PHASE 4
 STATE JOB NO. 09032(08)
 OKLAHOMA COUNTY SHEET NO. X066

3/4/2024 3:55:58 PM H:\PROJECTS\2785_CrossRoads_Phase 4\Roadway\Drawings\Sections\0903208-XSEC-CRL-WB-1-240.dgn

(CAUTION) THE LOCATION OF ALL UTILITIES AS SHOWN ARE APPROXIMATE. DUE TO RELOCATION'S PLANNED OR PRESENTLY UNDER CONSTRUCTION THERE ARE SOME UTILITIES THAT WILL BE RELOCATED AND NOT SHOWN ON THESE PLANS. THE CONTRACTOR SHALL BE RESPONSIBLE FOR ANY DAMAGE TO ALL UTILITIES. DEPTH & LOCATION OF EXISTING UTILITIES SHALL BE FIELD VERIFIED BY THE CONTRACTOR PRIOR TO CONSTRUCTION.

SEE DRAINAGE AREA MAP SHEETS FOR DRAINAGE SYMBOLOLOGY.

R/W & U/E PURCHASED UNDER JP 09032(05)

POB & ASSOCIATES, OKLAHOMA CITY, OK.
90% PLAN
SUBMITTAL
 3/4/2024

AREA
 CUT FILL

VOLUME
 CUT FILL

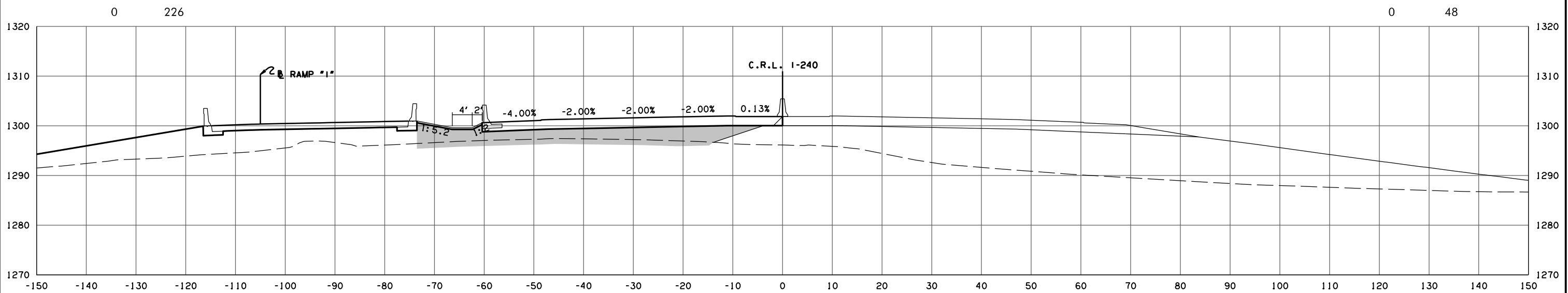

F.G. ELEV. = 1301.98
 A 431+05.83
 END OUTSIDE SHOULDER ROTATION

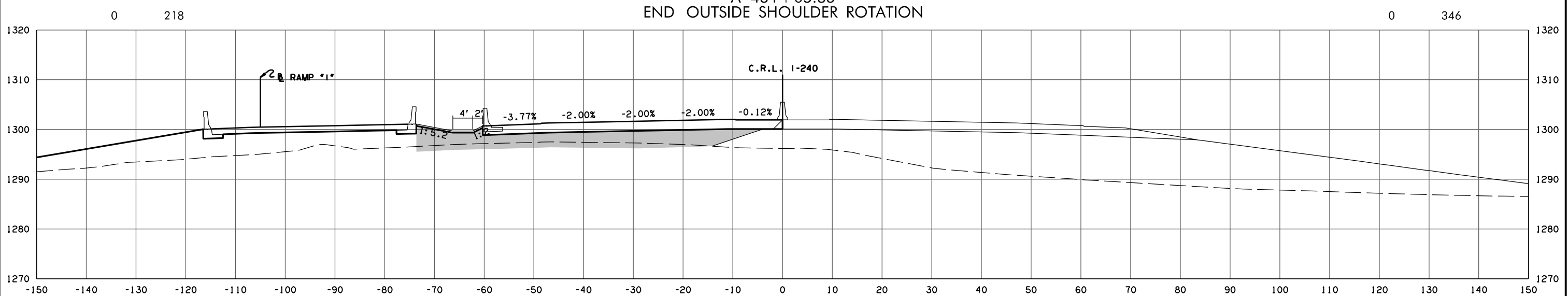

F.G. ELEV. = 1302.03
 A 431+00.00

CRL 1-240 W.B. PHASE 4
 STATE JOB NO. 09032(08)
 OKLAHOMA COUNTY SHEET NO. X067



3/4/2024 3:56:00 PM H:\PROJECTS\2789_CrossRoads_Phase 4\Roadway\Drawings\Sections\0903208-XSEC-CRL-WB-1-240.dgn

(CAUTION) THE LOCATION OF ALL UTILITIES AS SHOWN ARE APPROXIMATE. DUE TO RELOCATION'S PLANNED OR PRESENTLY UNDER CONSTRUCTION THERE ARE SOME UTILITIES THAT WILL BE RELOCATED AND NOT SHOWN ON THESE PLANS. THE CONTRACTOR SHALL BE RESPONSIBLE FOR ANY DAMAGE TO ALL UTILITIES. DEPTH & LOCATION OF EXISTING UTILITIES SHALL BE FIELD VERIFIED BY THE CONTRACTOR PRIOR TO CONSTRUCTION.

SEE DRAINAGE AREA MAP SHEETS FOR DRAINAGE SYMBOLOLOGY.

R/W & U/E PURCHASED UNDER JP 09032(05)

POB & ASSOCIATES, OKLAHOMA CITY, OK
90% PLAN
SUBMITTAL
 3/4/2024

AREA
 CUT  FILL 

VOLUME
 CUT FILL

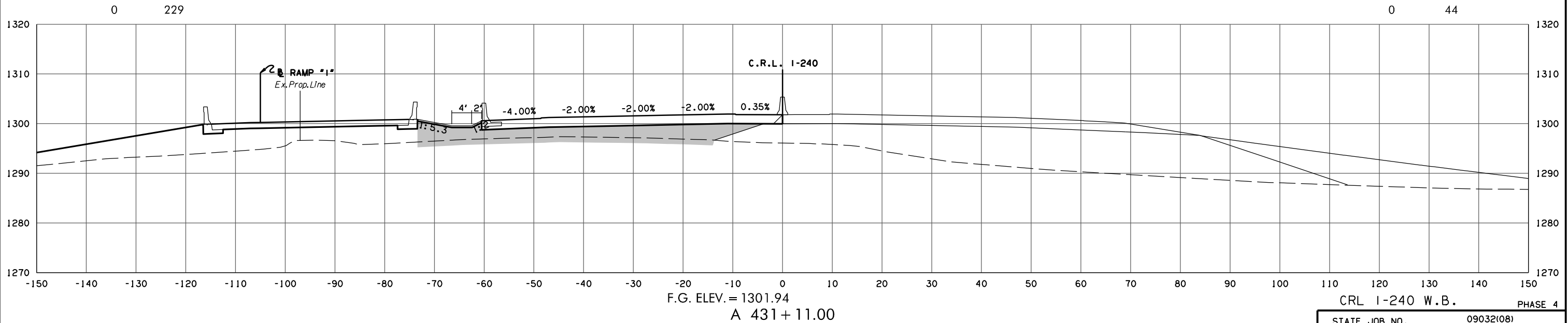
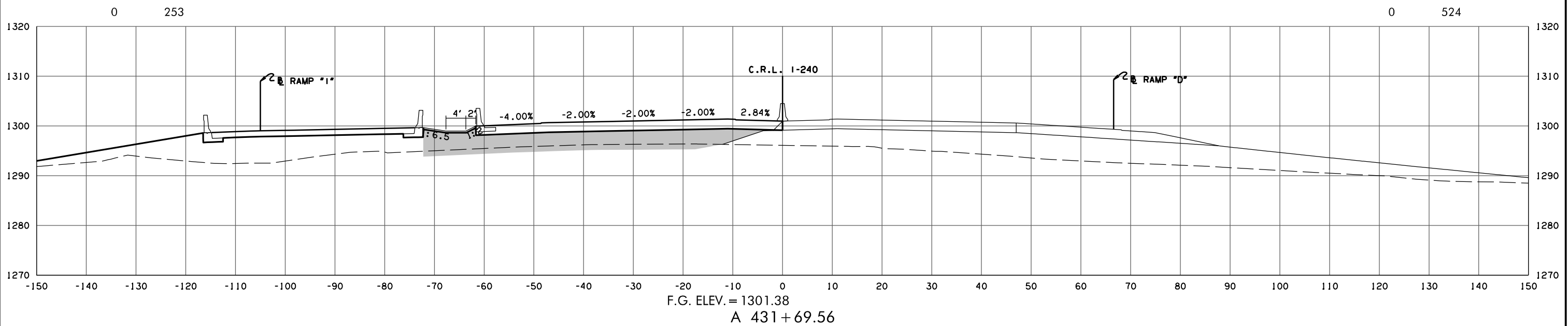

3/4/2024 3:56:02 PM H:\PROJECTS\2789_CrossRoads_Phase 4\Roadway\Drawings\Sections\0903208-XSEC.CRL.WB.1-240.dgn

CRL 1-240 W.B. PHASE 4
 STATE JOB NO. 09032(08)
 OKLAHOMA COUNTY SHEET NO. X068

(CAUTION) THE LOCATION OF ALL UTILITIES AS SHOWN ARE APPROXIMATE. DUE TO RELOCATION'S PLANNED OR PRESENTLY UNDER CONSTRUCTION THERE ARE SOME UTILITIES THAT WILL BE RELOCATED AND NOT SHOWN ON THESE PLANS. THE CONTRACTOR SHALL BE RESPONSIBLE FOR ANY DAMAGE TO ALL UTILITIES.
 DEPTH & LOCATION OF EXISTING UTILITIES SHALL BE FIELD VERIFIED BY THE CONTRACTOR PRIOR TO CONSTRUCTION.

SEE DRAINAGE AREA MAP SHEETS FOR DRAINAGE SYMBOLOLOGY.

R/W & U/E PURCHASED UNDER JP 09032(05)

POB & ASSOCIATES, OKLAHOMA CITY, OK.
90% PLAN SUBMITTAL
 3/4/2024

AREA
 CUT FILL

VOLUME
 CUT FILL

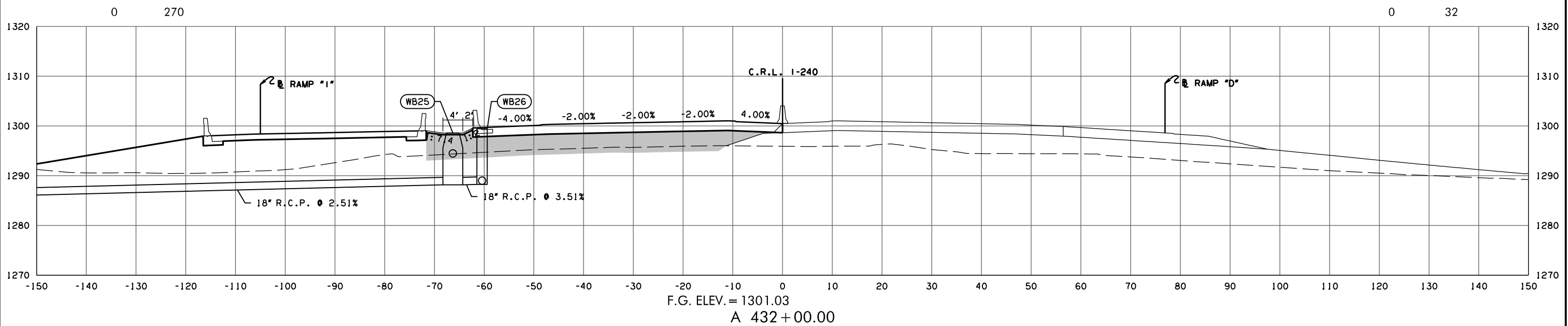

F.G. ELEV. = 1301.03
 A 432+00.00

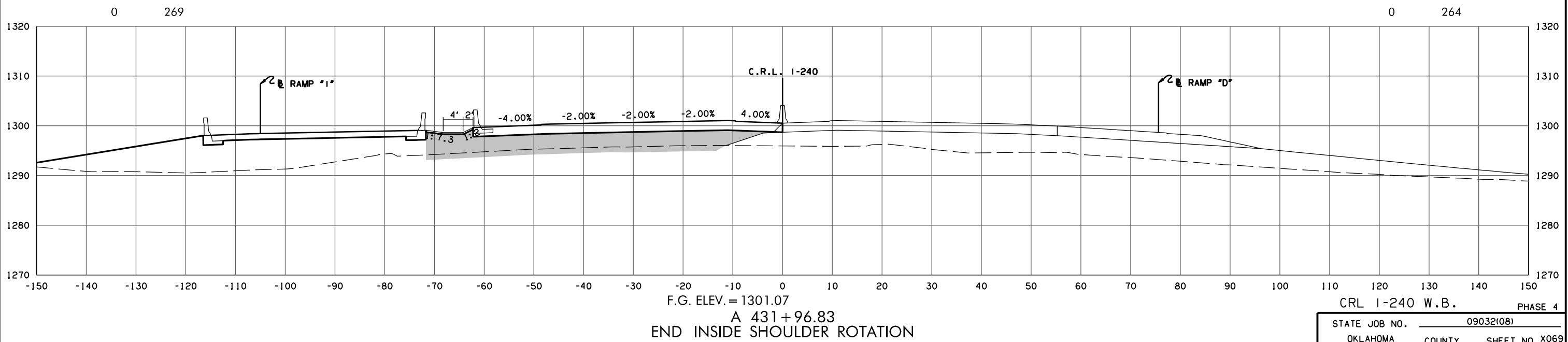

F.G. ELEV. = 1301.07
 A 431+96.83
 END INSIDE SHOULDER ROTATION

CRL I-240 W.B. PHASE 4
 STATE JOB NO. 09032(08)
 OKLAHOMA COUNTY SHEET NO. X069

3/4/2024 3:56:04 PM H:\PROJECTS\2789_CrossRoads_Phase 4\Roadway\Drawings\Sections\0903208-XSEC-CRL-WB-I-240.dgn

(CAUTION) THE LOCATION OF ALL UTILITIES AS SHOWN ARE APPROXIMATE. DUE TO RELOCATION'S PLANNED OR PRESENTLY UNDER CONSTRUCTION THERE ARE SOME UTILITIES THAT WILL BE RELOCATED AND NOT SHOWN ON THESE PLANS. THE CONTRACTOR SHALL BE RESPONSIBLE FOR ANY DAMAGE TO ALL UTILITIES.
 DEPTH & LOCATION OF EXISTING UTILITIES SHALL BE FIELD VERIFIED BY THE CONTRACTOR PRIOR TO CONSTRUCTION.

SEE DRAINAGE AREA MAP SHEETS FOR DRAINAGE SYMBOLOLOGY.

R/W & U/E PURCHASED UNDER JP 09032(05)

POB & ASSOCIATES, OKLAHOMA CITY, OK.
90% PLAN SUBMITTAL
 3/4/2024

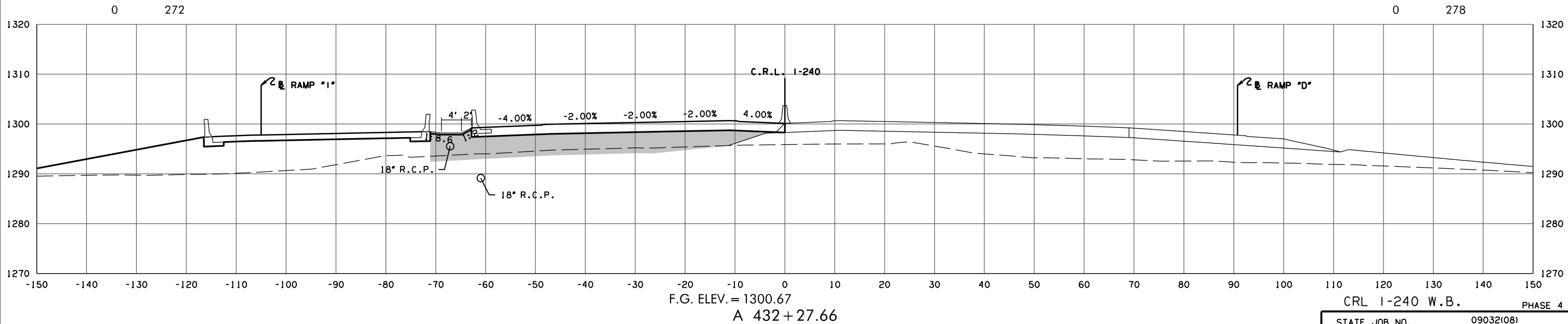
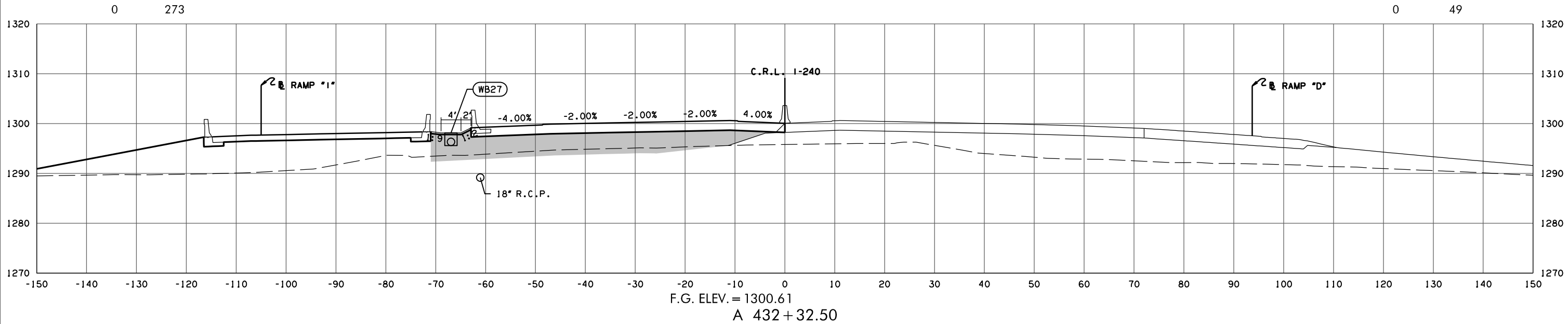
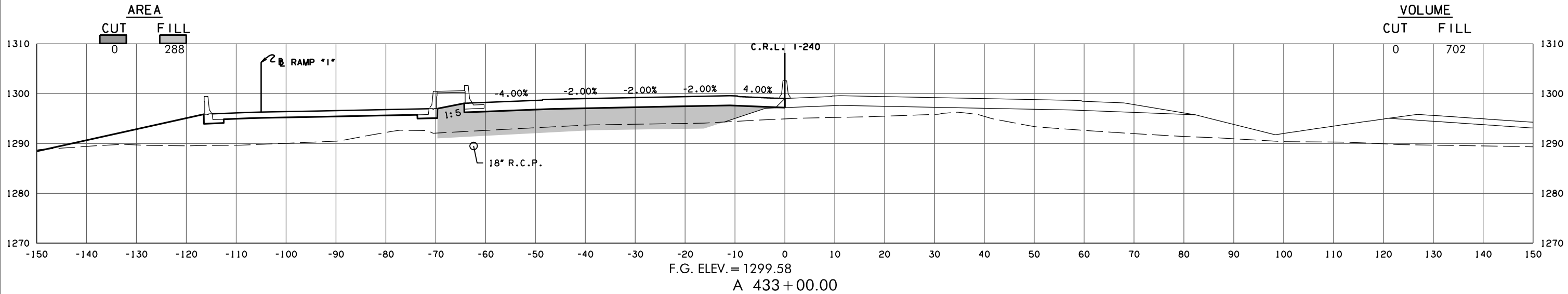

3/4/2024 3:56:05 PM H:\PROJECTS\2789_CrossRoads_Phase 4\Roadway\Drawings\Sections\0903208-XSEC.CRL.WB.1-240.dgn

CRL 1-240 W.B. PHASE 4
 STATE JOB NO. 09032(08)
 OKLAHOMA COUNTY SHEET NO. X070

(CAUTION) THE LOCATION OF ALL UTILITIES AS SHOWN ARE APPROXIMATE. DUE TO RELOCATION'S PLANNED OR PRESENTLY UNDER CONSTRUCTION THERE ARE SOME UTILITIES THAT WILL BE RELOCATED AND NOT SHOWN ON THESE PLANS. THE CONTRACTOR SHALL BE RESPONSIBLE FOR ANY DAMAGE TO ALL UTILITIES.
 DEPTH & LOCATION OF EXISTING UTILITIES SHALL BE FIELD VERIFIED BY THE CONTRACTOR PRIOR TO CONSTRUCTION.

SEE DRAINAGE AREA MAP SHEETS FOR DRAINAGE SYMBOLOLOGY.

R/W & U/E PURCHASED UNDER JP 09032(05)

POB & ASSOCIATES, OKLAHOMA CITY, OK.
90% PLAN SUBMITTAL
 3/4/2024

AREA
 CUT FILL

VOLUME
 CUT FILL

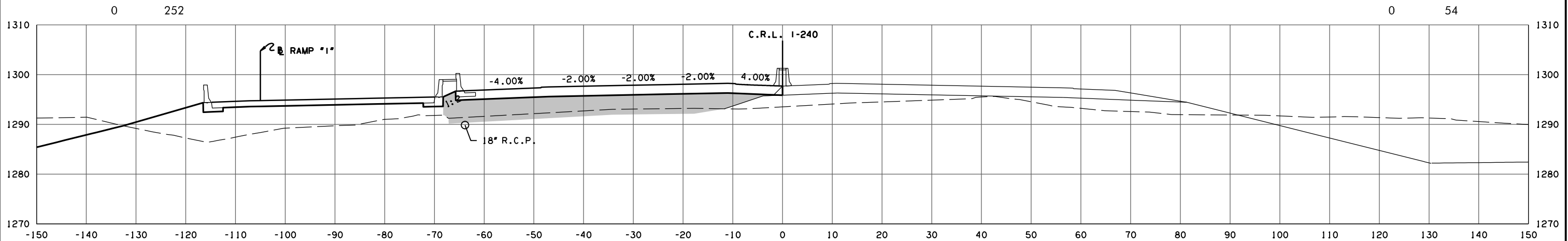

F.G. ELEV. = 1298.25
 A 433+72.00

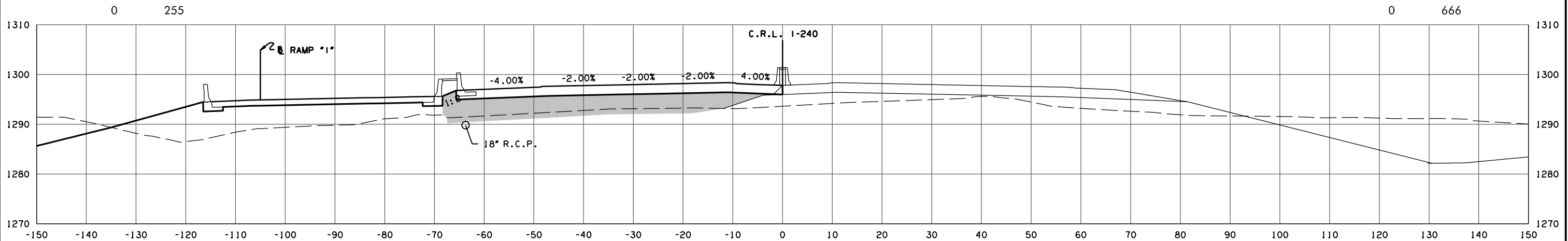

F.G. ELEV. = 1298.36
 A 433+66.22

CRL 1-240 W.B. PHASE 4
 STATE JOB NO. 09032(08)
 OKLAHOMA COUNTY SHEET NO. X071

3/4/2024 3:56:07 PM
 H:\PROJECTS\2789_CrossRoads_Phase 4\Roadway\Drawings\Sections\0903208-XSEC-CRL-WB-1-240.dgn

(CAUTION) THE LOCATION OF ALL UTILITIES AS SHOWN ARE APPROXIMATE. DUE TO RELOCATION'S PLANNED OR PRESENTLY UNDER CONSTRUCTION THERE ARE SOME UTILITIES THAT WILL BE RELOCATED AND NOT SHOWN ON THESE PLANS. THE CONTRACTOR SHALL BE RESPONSIBLE FOR ANY DAMAGE TO ALL UTILITIES.

DEPTH & LOCATION OF EXISTING UTILITIES SHALL BE FIELD VERIFIED BY THE CONTRACTOR PRIOR TO CONSTRUCTION.

SEE DRAINAGE AREA MAP SHEETS FOR DRAINAGE SYMBOLOLOGY.

R/W & U/E PURCHASED UNDER JP 09032(05)

POB & ASSOCIATES, OKLAHOMA CITY, OK.

**90% PLAN
SUBMITTAL**

3/4/2024

AREA
CUT FILL

VOLUME
CUT FILL

0 169

0 444

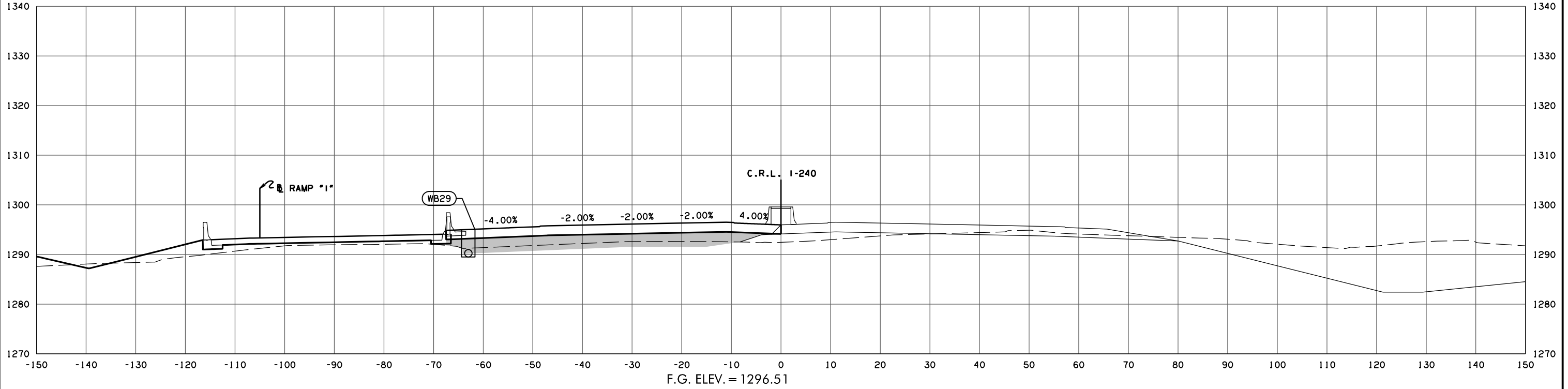

F.G. ELEV. = 1296.51
A 434 + 59.79

0 232

0 251

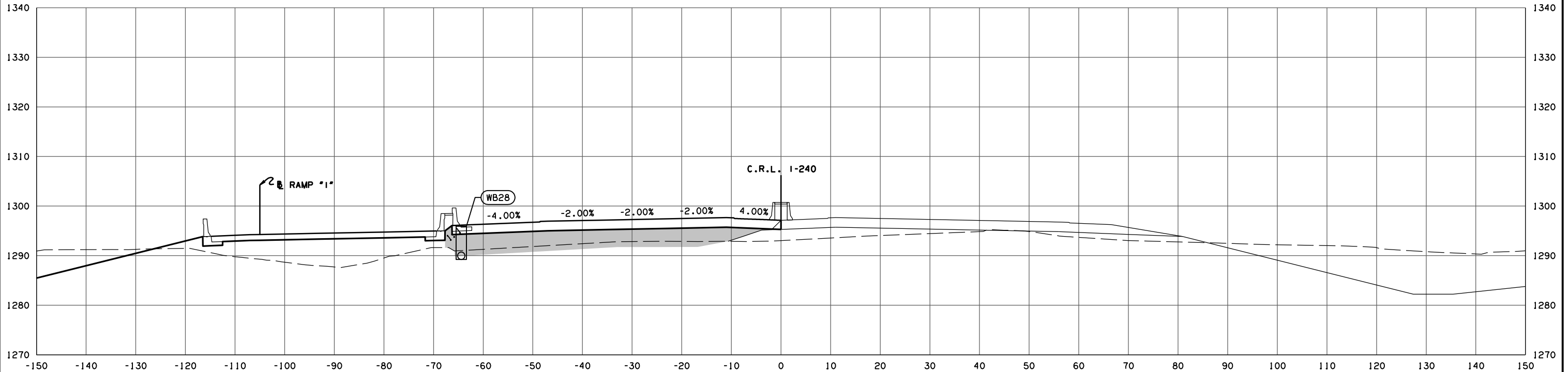

F.G. ELEV. = 1297.67
A 434 + 00.00

CRL 1-240 W.B. PHASE 4

STATE JOB NO. 09032(08)
OKLAHOMA COUNTY SHEET NO. X072

3/4/2024 3:56:09 PM
H:\PROJECTS\2789_CrossRoads_Phase 4\Roadway\Drawings\Sections\0903208-XSEC.CRL.WB.1-240.dgn

(CAUTION) THE LOCATION OF ALL UTILITIES AS SHOWN ARE APPROXIMATE. DUE TO RELOCATION'S PLANNED OR PRESENTLY UNDER CONSTRUCTION THERE ARE SOME UTILITIES THAT WILL BE RELOCATED AND NOT SHOWN ON THESE PLANS. THE CONTRACTOR SHALL BE RESPONSIBLE FOR ANY DAMAGE TO ALL UTILITIES.

SEE DRAINAGE AREA MAP SHEETS FOR DRAINAGE SYMBOLOLOGY.

R/W & U/E PURCHASED UNDER JP 09032(05)

POB & ASSOCIATES, OKLAHOMA CITY, OK.

**90% PLAN
SUBMITTAL**

3/4/2024

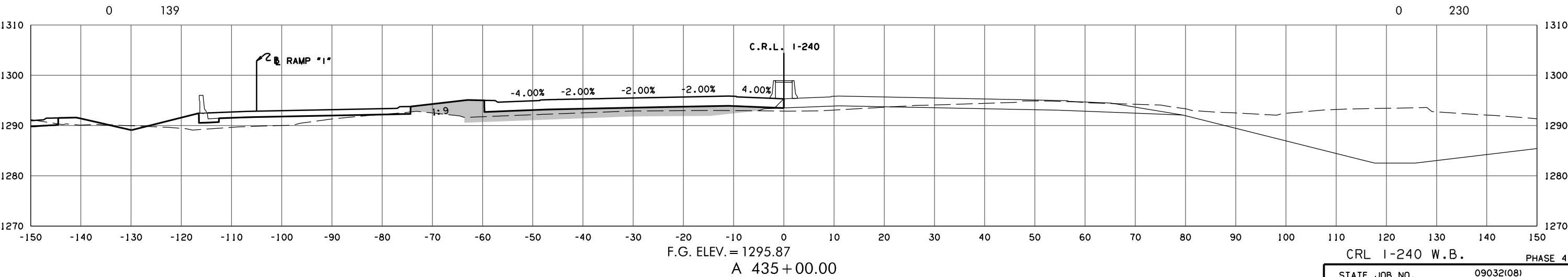
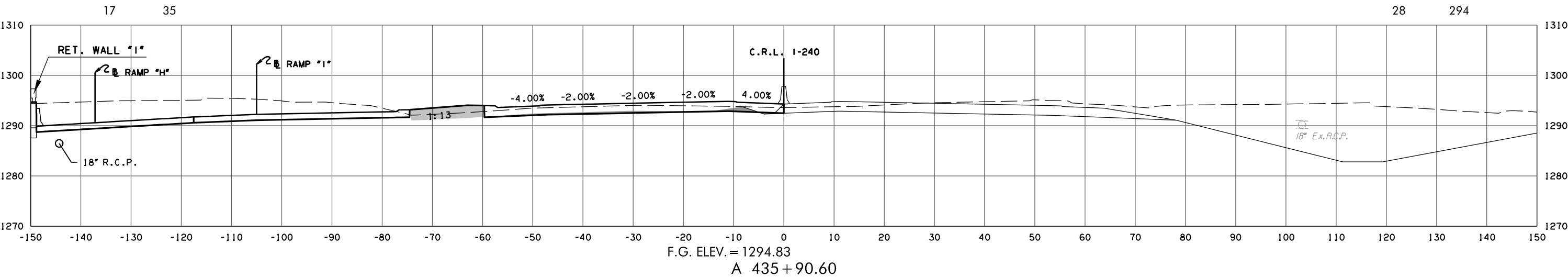
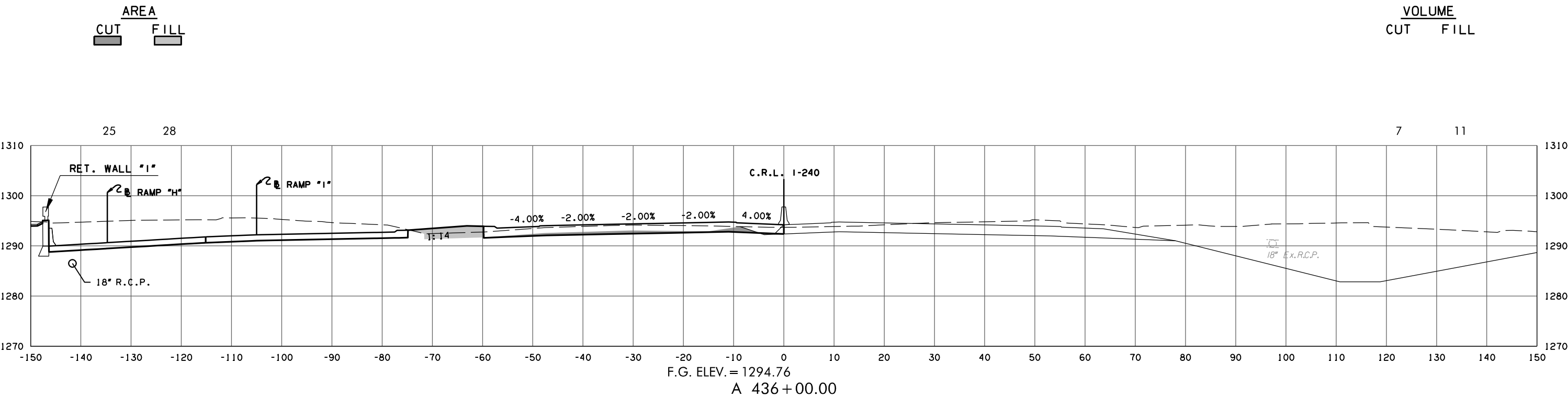

VOLUME
CUT FILL

25 28

7 11

17 35

28 294

0 139

0 230

CRL 1-240 W.B. PHASE 4

STATE JOB NO.	09032(08)
OKLAHOMA COUNTY	SHEET NO. X073

3/4/2024 3:56:40 PM H:\PROJECTS\2789_CrossRoads_Phase 4\Roadway\Drawings\Sections\0903208-XSEC.CRL.WB.1-240.dgn

(CAUTION) THE LOCATION OF ALL UTILITIES AS SHOWN ARE APPROXIMATE. DUE TO RELOCATION'S PLANNED OR PRESENTLY UNDER CONSTRUCTION THERE ARE SOME UTILITIES THAT WILL BE RELOCATED AND NOT SHOWN ON THESE PLANS. THE CONTRACTOR SHALL BE RESPONSIBLE FOR ANY DAMAGE TO ALL UTILITIES.

SEE DRAINAGE AREA MAP SHEETS FOR DRAINAGE SYMBOLOLOGY.

R/W & U/E PURCHASED UNDER JP 09032(05)

POB & ASSOCIATES, OKLAHOMA CITY, OK.

**90% PLAN
SUBMITTAL**

3/4/2024

AREA
CUT FILL

VOLUME
CUT FILL

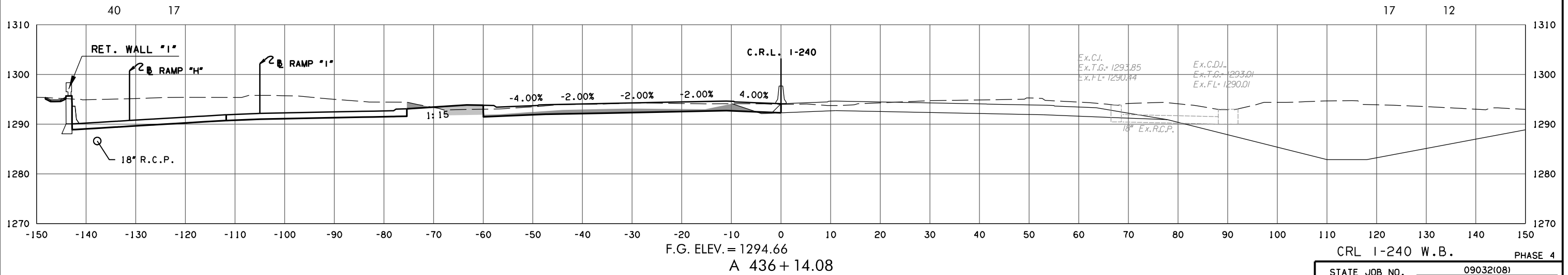
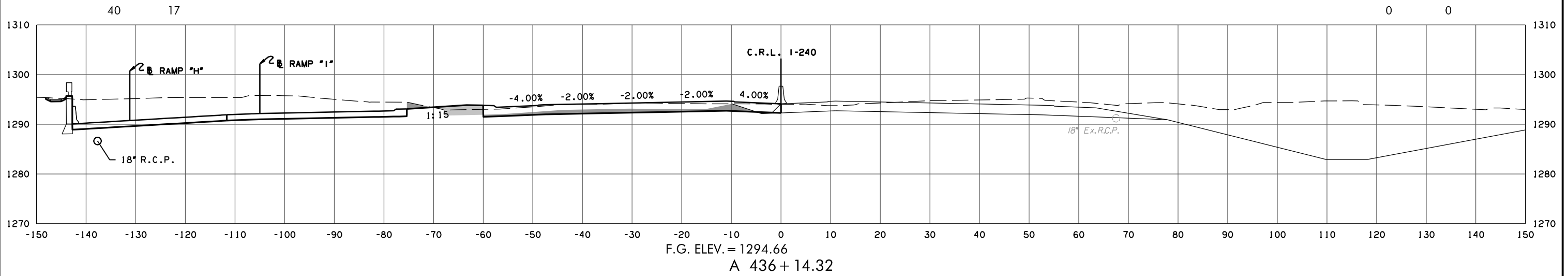
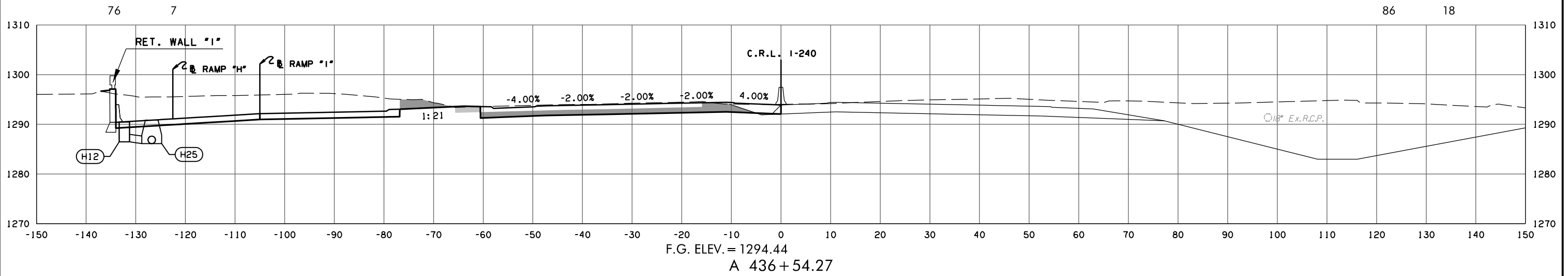

3/4/2024 3:56:42 PM H:\PROJECTS\2789_CrossRoads_Phase 4\Roadway\Drawings\Sections\0903208-XSEC.CRL.WB.1-240.dgn

(CAUTION) THE LOCATION OF ALL UTILITIES AS SHOWN ARE APPROXIMATE. DUE TO RELOCATION'S PLANNED OR PRESENTLY UNDER CONSTRUCTION THERE ARE SOME UTILITIES THAT WILL BE RELOCATED AND NOT SHOWN ON THESE PLANS. THE CONTRACTOR SHALL BE RESPONSIBLE FOR ANY DAMAGE TO ALL UTILITIES.

DEPTH & LOCATION OF EXISTING UTILITIES SHALL BE FIELD VERIFIED BY THE CONTRACTOR PRIOR TO CONSTRUCTION.

SEE DRAINAGE AREA MAP SHEETS FOR DRAINAGE SYMBOLOLOGY.

R/W & U/E PURCHASED UNDER JP 09032(05)

POB & ASSOCIATES, OKLAHOMA CITY, OK.

**90% PLAN
SUBMITTAL**

3/4/2024

AREA
CUT FILL

VOLUME
CUT FILL

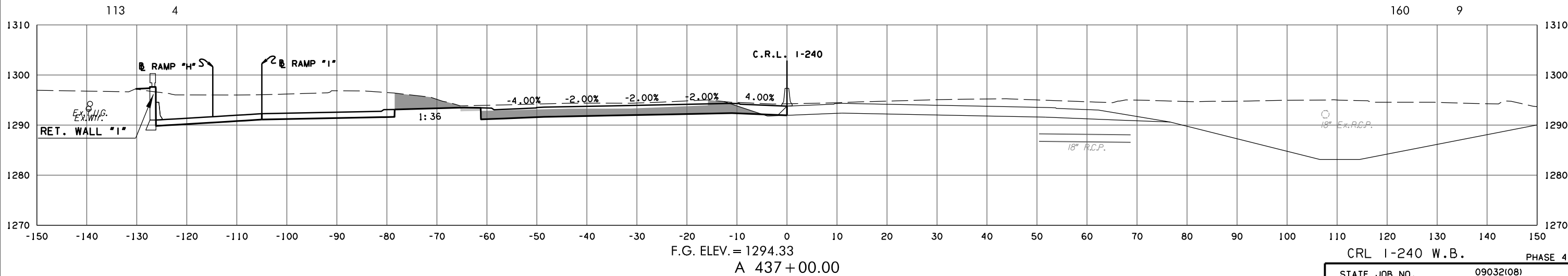
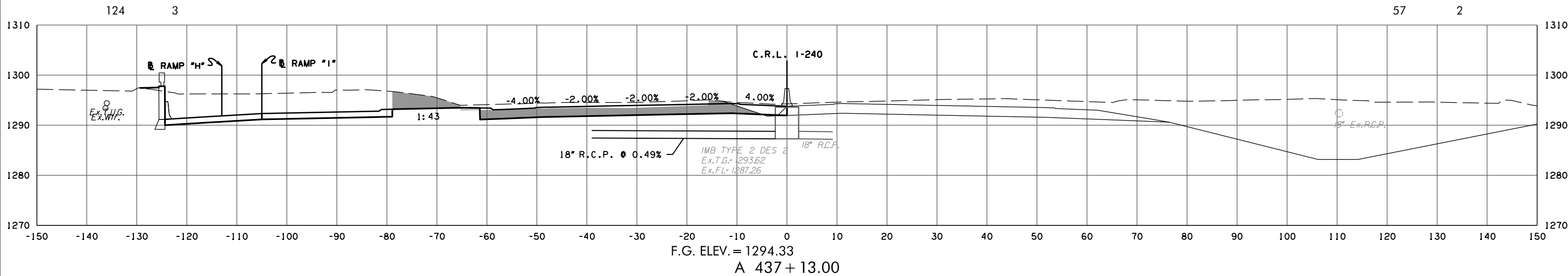
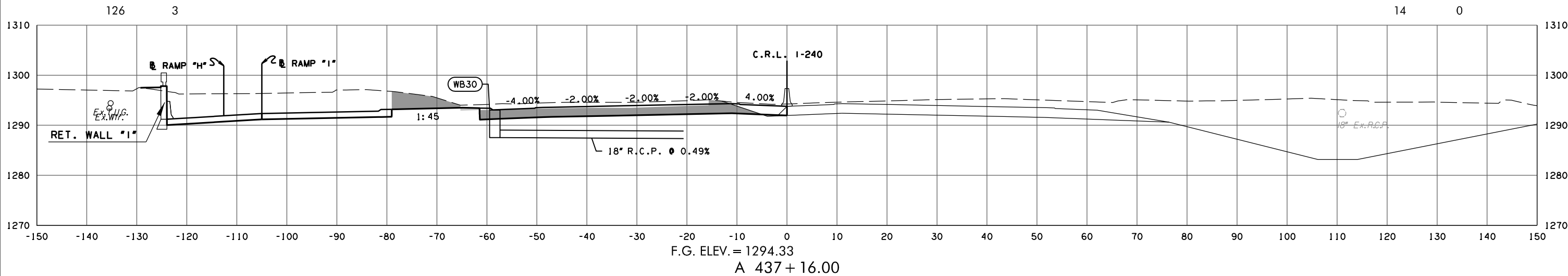

CRL 1-240 W.B. PHASE 4
STATE JOB NO. 09032(08)
OKLAHOMA COUNTY SHEET NO. X075

3/4/2024 3:56:14 PM H:\PROJECTS\2789_CrossRoads_Phase 4\Roadway\Drawings\Sections\0903208-XSEC_CRL_WB_1-240.dgn

(CAUTION) THE LOCATION OF ALL UTILITIES AS SHOWN ARE APPROXIMATE. DUE TO RELOCATION'S PLANNED OR PRESENTLY UNDER CONSTRUCTION THERE ARE SOME UTILITIES THAT WILL BE RELOCATED AND NOT SHOWN ON THESE PLANS. THE CONTRACTOR SHALL BE RESPONSIBLE FOR ANY DAMAGE TO ALL UTILITIES.

SEE DRAINAGE AREA MAP SHEETS FOR DRAINAGE SYMBOLOLOGY.

R/W & U/E PURCHASED UNDER JP 09032(05)

POB & ASSOCIATES, OKLAHOMA CITY, OK.

90% PLAN SUBMITTAL

3/4/2024

DEPTH & LOCATION OF EXISTING UTILITIES SHALL BE FIELD VERIFIED BY THE CONTRACTOR PRIOR TO CONSTRUCTION.

AREA
CUT FILL

VOLUME
CUT FILL

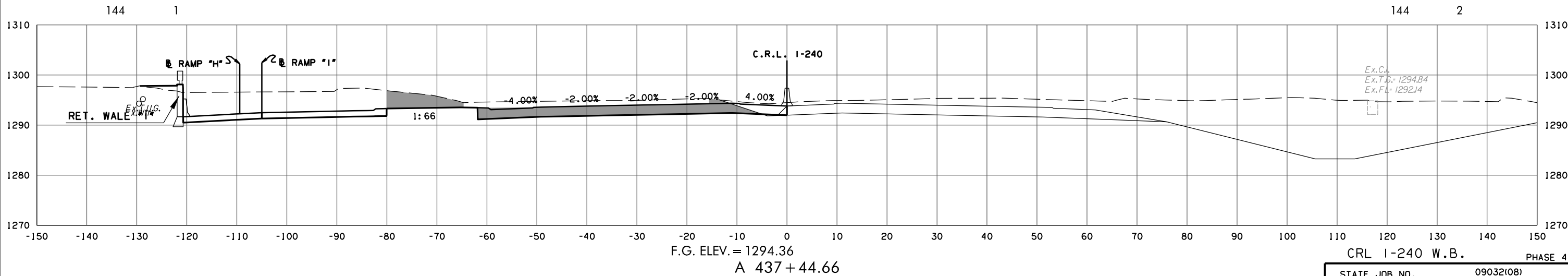
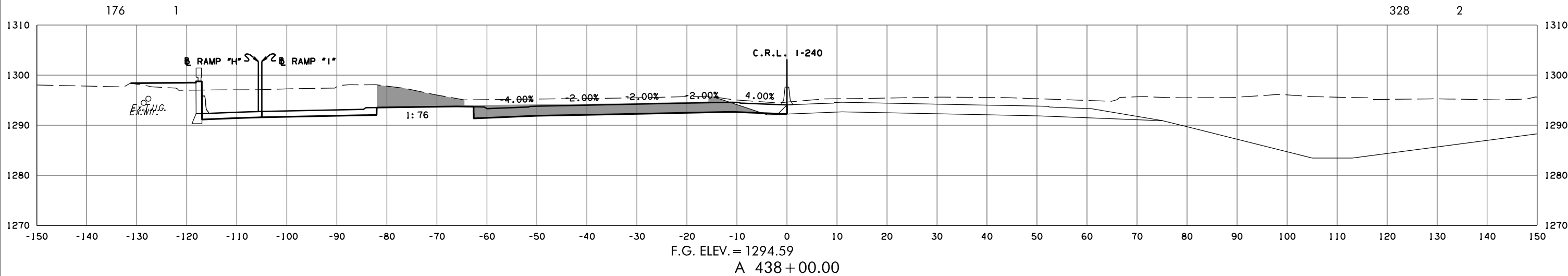
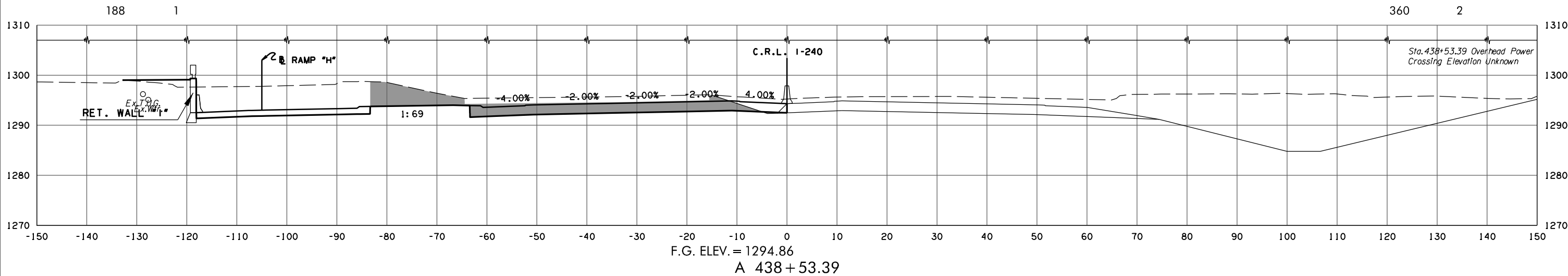

CRL 1-240 W.B. PHASE 4
STATE JOB NO. 09032(08)
OKLAHOMA COUNTY SHEET NO. X076

3/4/2024 3:56:45 PM H:\PROJECTS\2789_CrossRoads_Phase 4\Roadway\Drawings\Sections\0903208-XSEC.CRL.WB.1-240.dgn

(CAUTION) THE LOCATION OF ALL UTILITIES AS SHOWN ARE APPROXIMATE. DUE TO RELOCATION'S PLANNED OR PRESENTLY UNDER CONSTRUCTION THERE ARE SOME UTILITIES THAT WILL BE RELOCATED AND NOT SHOWN ON THESE PLANS. THE CONTRACTOR SHALL BE RESPONSIBLE FOR ANY DAMAGE TO ALL UTILITIES.
 DEPTH & LOCATION OF EXISTING UTILITIES SHALL BE FIELD VERIFIED BY THE CONTRACTOR PRIOR TO CONSTRUCTION.

SEE DRAINAGE AREA MAP SHEETS FOR DRAINAGE SYMBOLOLOGY.

R/W & U/E PURCHASED UNDER JP 09032(05)

POB & ASSOCIATES, OKLAHOMA CITY, OK.
90% PLAN SUBMITTAL
 3/4/2024

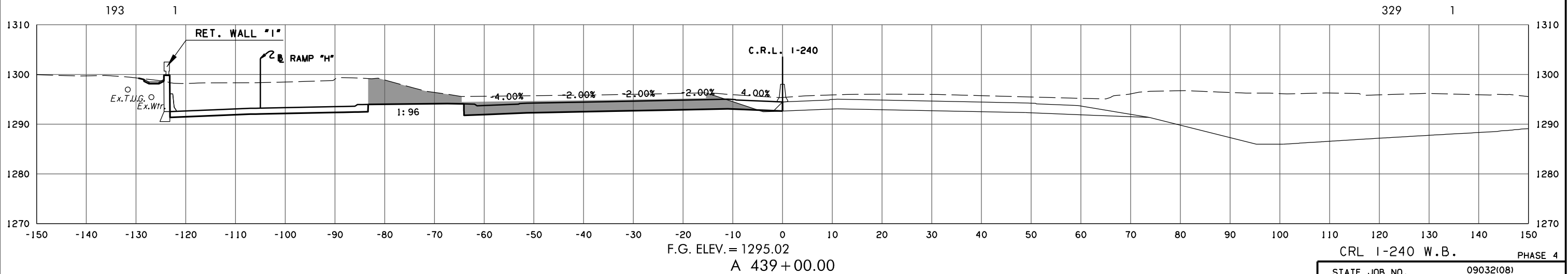
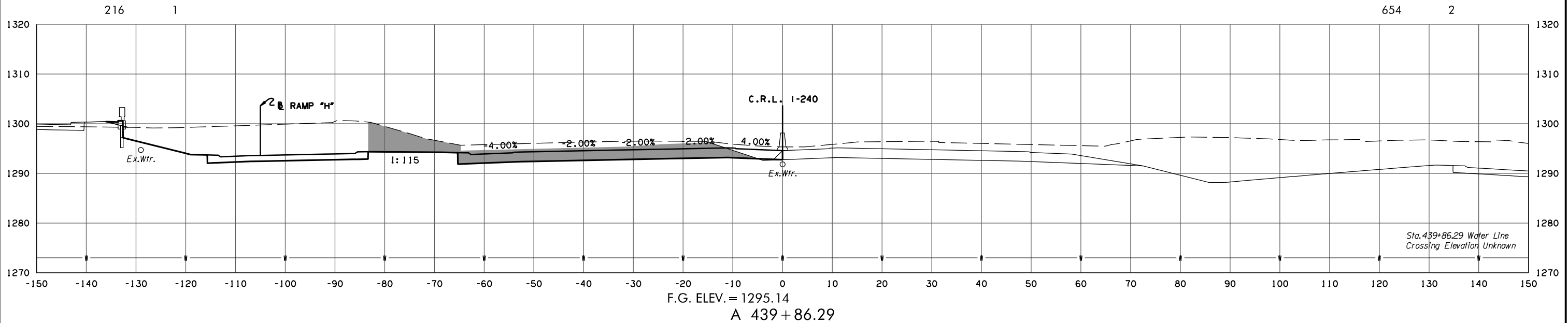
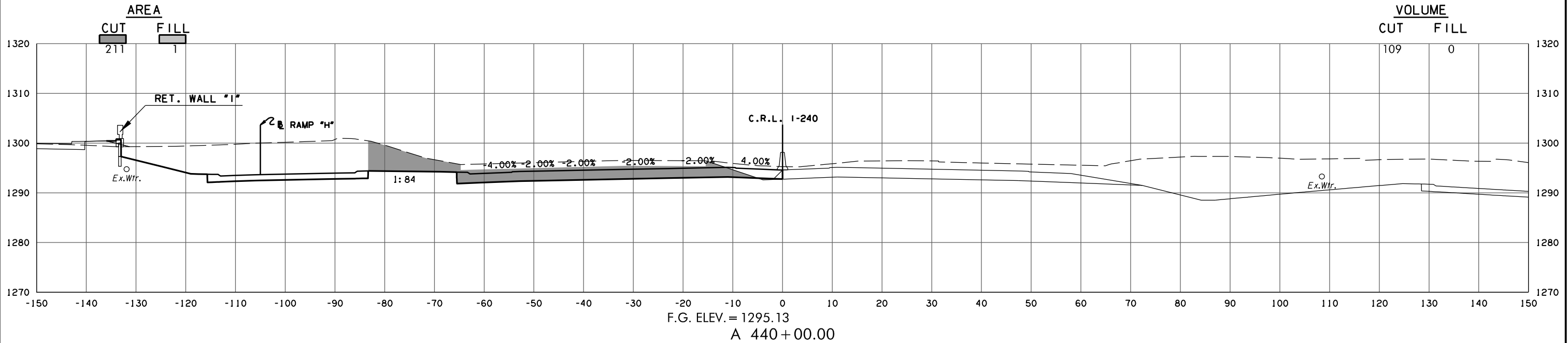

CRL 1-240 W.B. PHASE 4
 STATE JOB NO. 09032(08)
 OKLAHOMA COUNTY SHEET NO. X077

3/4/2024 3:56:17 PM H:\PROJECTS\2789_CrossRoads_Phase 4\Roadway\Drawings\Sections\0903208-XSEC.CRL.WB.1-240.dgn

(CAUTION) THE LOCATION OF ALL UTILITIES AS SHOWN ARE APPROXIMATE. DUE TO RELOCATION'S PLANNED OR PRESENTLY UNDER CONSTRUCTION THERE ARE SOME UTILITIES THAT WILL BE RELOCATED AND NOT SHOWN ON THESE PLANS. THE CONTRACTOR SHALL BE RESPONSIBLE FOR ANY DAMAGE TO ALL UTILITIES.
 DEPTH & LOCATION OF EXISTING UTILITIES SHALL BE FIELD VERIFIED BY THE CONTRACTOR PRIOR TO CONSTRUCTION.

SEE DRAINAGE AREA MAP SHEETS FOR DRAINAGE SYMBOLOLOGY.

R/W & U/E PURCHASED UNDER JP 09032(05)

POB & ASSOCIATES, OKLAHOMA CITY, OK.
90% PLAN SUBMITTAL
 3/4/2024

AREA
 CUT FILL

VOLUME
 CUT FILL

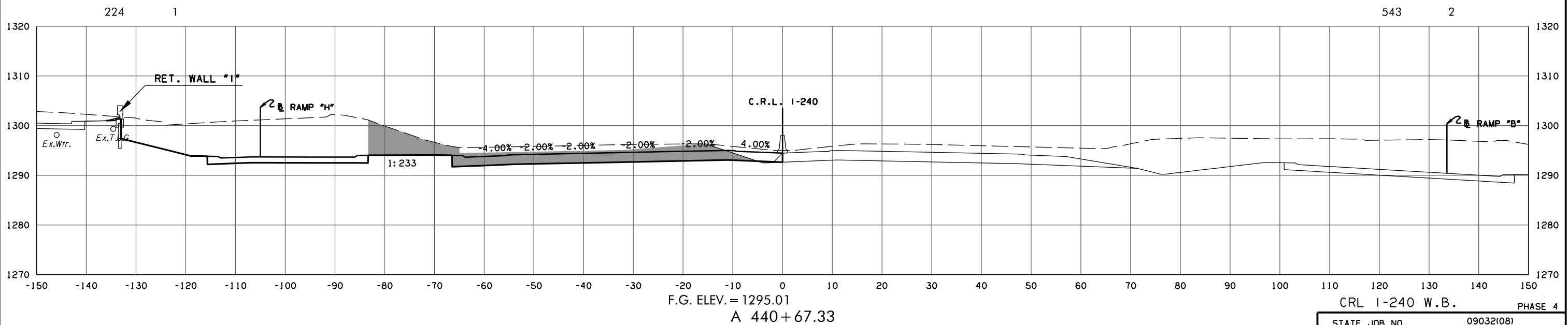
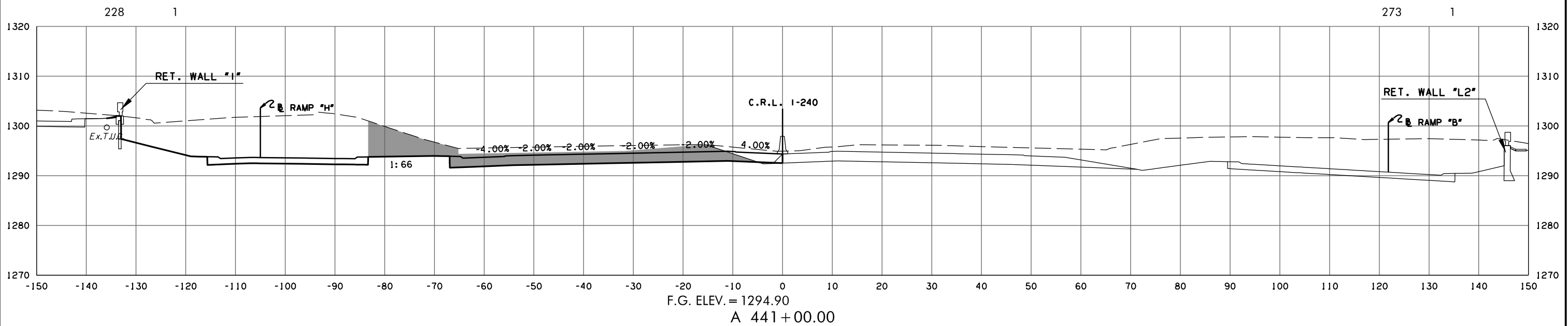

CRL 1-240 W.B. PHASE 4
 STATE JOB NO. 09032(08)
 OKLAHOMA COUNTY SHEET NO. X078

3/4/2024 3:56:49 PM
 H:\PROJECTS\2789_CrossRoads_Phase 4\Roadway\Drawings\Sections\0903208-XSEC.CRL.WB.1-240.dgn

(CAUTION) THE LOCATION OF ALL UTILITIES AS SHOWN ARE APPROXIMATE. DUE TO RELOCATION'S PLANNED OR PRESENTLY UNDER CONSTRUCTION THERE ARE SOME UTILITIES THAT WILL BE RELOCATED AND NOT SHOWN ON THESE PLANS. THE CONTRACTOR SHALL BE RESPONSIBLE FOR ANY DAMAGE TO ALL UTILITIES.
 DEPTH & LOCATION OF EXISTING UTILITIES SHALL BE FIELD VERIFIED BY THE CONTRACTOR PRIOR TO CONSTRUCTION.

SEE DRAINAGE AREA MAP SHEETS FOR DRAINAGE SYMBOLOLOGY.

R/W & U/E PURCHASED UNDER JP 09032(05)

POB & ASSOCIATES, OKLAHOMA CITY, OK.

90% PLAN SUBMITTAL

3/4/2024

AREA
 CUT FILL

VOLUME
 CUT FILL

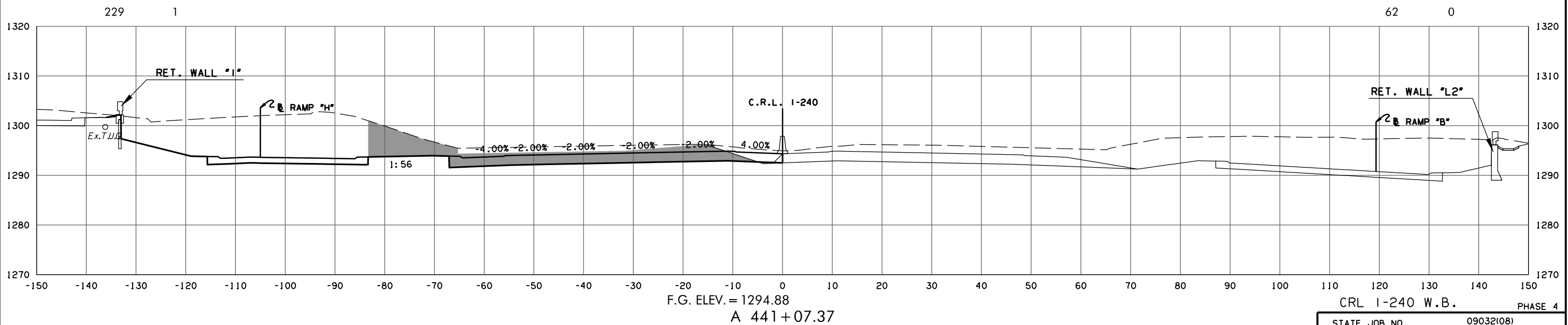
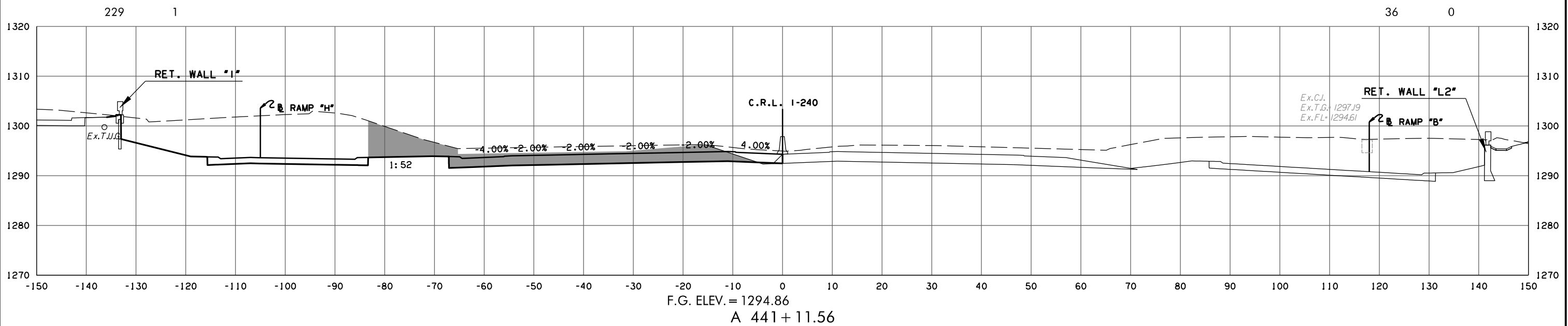

CRL 1-240 W.B. PHASE 4
 STATE JOB NO. 09032(08)
 OKLAHOMA COUNTY SHEET NO. X079

3/4/2024 3:56:21 PM H:\PROJECTS\2789_CrossRoads_Phase 4\Roadway\Drawings\Sections\0903208-XSEC-CRL-WB-1-240.dgn

(CAUTION) THE LOCATION OF ALL UTILITIES AS SHOWN ARE APPROXIMATE. DUE TO RELOCATION'S PLANNED OR PRESENTLY UNDER CONSTRUCTION THERE ARE SOME UTILITIES THAT WILL BE RELOCATED AND NOT SHOWN ON THESE PLANS. THE CONTRACTOR SHALL BE RESPONSIBLE FOR ANY DAMAGE TO ALL UTILITIES.
 DEPTH & LOCATION OF EXISTING UTILITIES SHALL BE FIELD VERIFIED BY THE CONTRACTOR PRIOR TO CONSTRUCTION.

SEE DRAINAGE AREA MAP SHEETS FOR DRAINAGE SYMBOLOLOGY.

R/W & U/E PURCHASED UNDER JP 09032(05)

POB & ASSOCIATES, OKLAHOMA CITY, OK.
90% PLAN SUBMITTAL
 3/4/2024

AREA
 CUT FILL

VOLUME
 CUT FILL

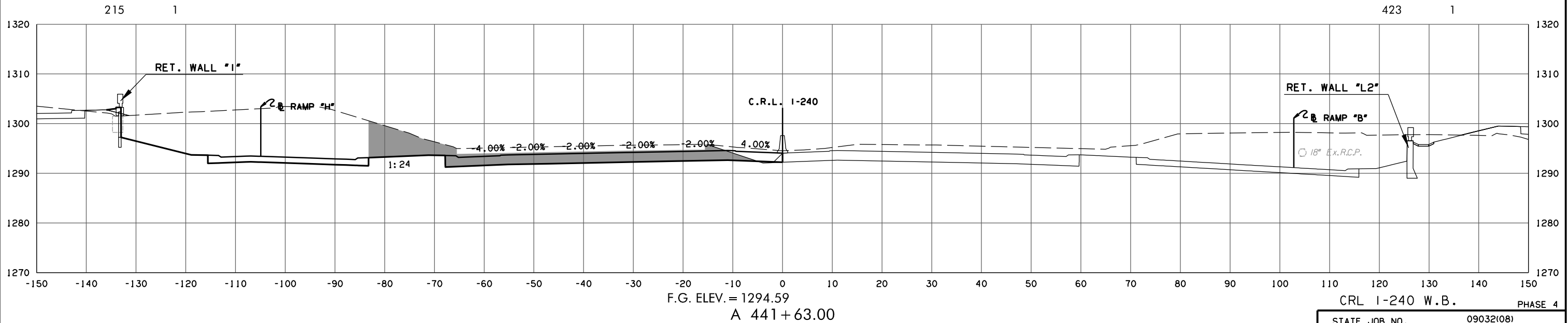
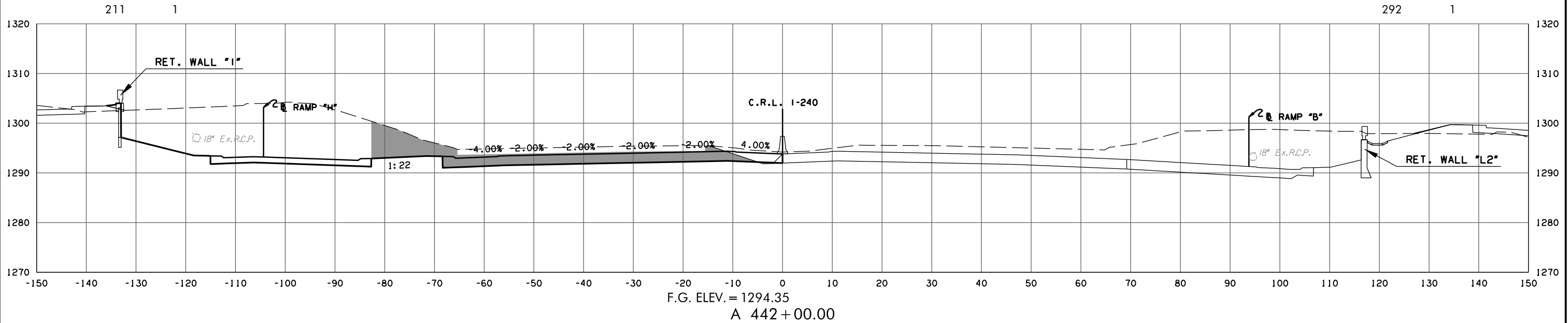

CRL 1-240 W.B. PHASE 4
 STATE JOB NO. 09032(08)
 OKLAHOMA COUNTY SHEET NO. X080

3/4/2024 3:56:22 PM H:\PROJECTS\2789_CrossRoads_Phase 4\Roadway\Drawings\Sections\0903208-XSEC-CRL-WB-1-240.dgn

(CAUTION) THE LOCATION OF ALL UTILITIES AS SHOWN ARE APPROXIMATE. DUE TO RELOCATION'S PLANNED OR PRESENTLY UNDER CONSTRUCTION THERE ARE SOME UTILITIES THAT WILL BE RELOCATED AND NOT SHOWN ON THESE PLANS. THE CONTRACTOR SHALL BE RESPONSIBLE FOR ANY DAMAGE TO ALL UTILITIES.
 DEPTH & LOCATION OF EXISTING UTILITIES SHALL BE FIELD VERIFIED BY THE CONTRACTOR PRIOR TO CONSTRUCTION.

SEE DRAINAGE AREA MAP SHEETS FOR DRAINAGE SYMBOLOLOGY.

R/W & U/E PURCHASED UNDER JP 09032(05)

POB & ASSOCIATES, OKLAHOMA CITY, OK.

**90% PLAN
 SUBMITTAL**

3/4/2024

AREA
 CUT FILL

VOLUME
 CUT FILL

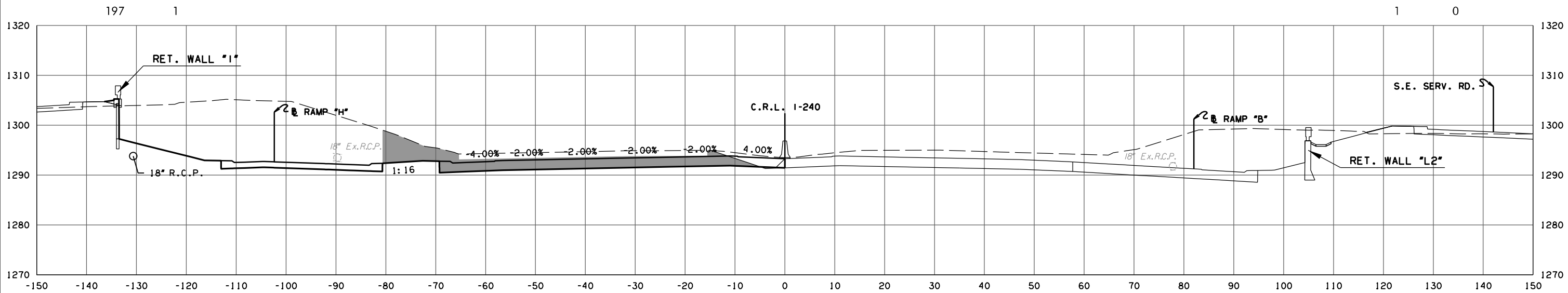

F.G. ELEV. = 1293.83
 A 442 + 62.94

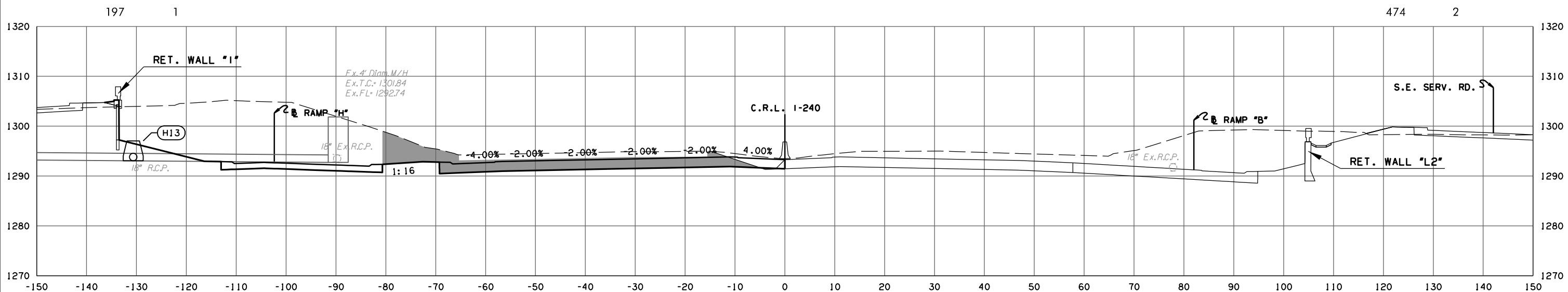

F.G. ELEV. = 1293.83
 A 442 + 62.82

CRL 1-240 W.B. PHASE 4

STATE JOB NO. 09032(08)
 OKLAHOMA COUNTY SHEET NO. X08

3/4/2024 3:56:24 PM
 H:\PROJECTS\2789_CrossRoads_Phase 4\Roadway\Drawings\Sections\0903208-XSEC-CRL-WB-1-240.dgn

(CAUTION) THE LOCATION OF ALL UTILITIES AS SHOWN ARE APPROXIMATE. DUE TO RELOCATION'S PLANNED OR PRESENTLY UNDER CONSTRUCTION THERE ARE SOME UTILITIES THAT WILL BE RELOCATED AND NOT SHOWN ON THESE PLANS. THE CONTRACTOR SHALL BE RESPONSIBLE FOR ANY DAMAGE TO ALL UTILITIES.
 DEPTH & LOCATION OF EXISTING UTILITIES SHALL BE FIELD VERIFIED BY THE CONTRACTOR PRIOR TO CONSTRUCTION.

SEE DRAINAGE AREA MAP SHEETS FOR DRAINAGE SYMBOLOLOGY.

R/W & U/E PURCHASED UNDER JP 09032(05)

POB & ASSOCIATES, OKLAHOMA CITY, OK.
90% PLAN SUBMITTAL
 3/4/2024

AREA
 CUT FILL

VOLUME
 CUT FILL

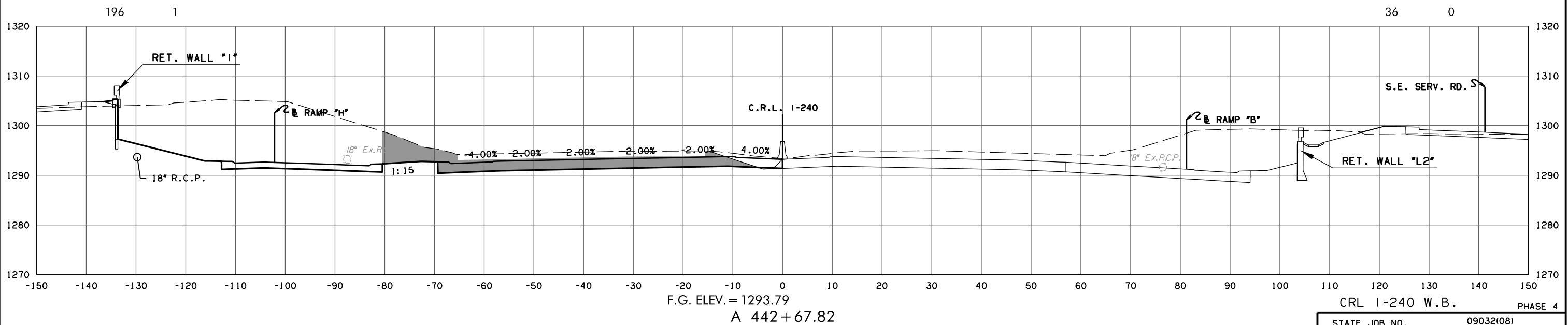
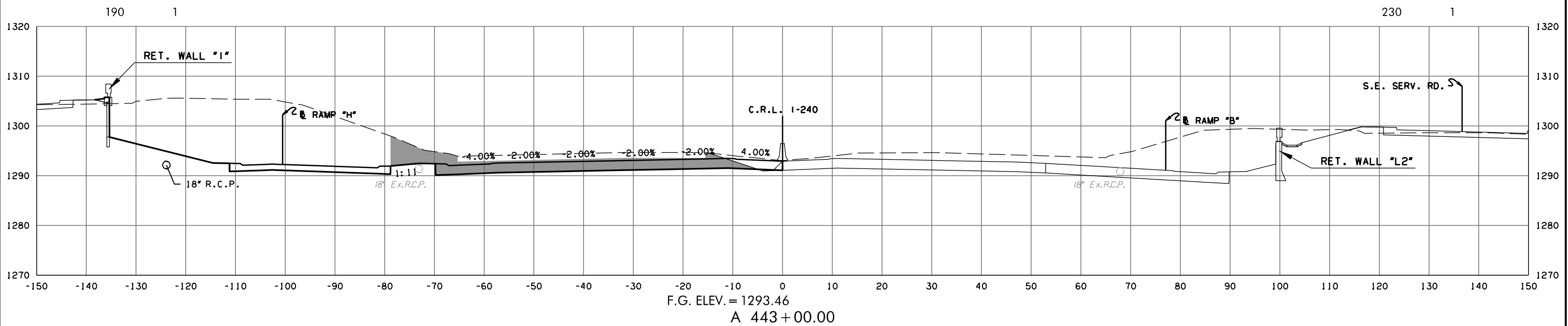

3/4/2024 3:56:26 PM H:\PROJECTS\2789_CrossRoads_Phase 4\Roadway\Drawings\Sections\0903208-XSEC-CRL-WB-1-240.dgn

CRL 1-240 W.B. PHASE 4
 STATE JOB NO. 09032(08)
 OKLAHOMA COUNTY SHEET NO. X082

(CAUTION) THE LOCATION OF ALL UTILITIES AS SHOWN ARE APPROXIMATE. DUE TO RELOCATION'S PLANNED OR PRESENTLY UNDER CONSTRUCTION THERE ARE SOME UTILITIES THAT WILL BE RELOCATED AND NOT SHOWN ON THESE PLANS. THE CONTRACTOR SHALL BE RESPONSIBLE FOR ANY DAMAGE TO ALL UTILITIES.
 DEPTH & LOCATION OF EXISTING UTILITIES SHALL BE FIELD VERIFIED BY THE CONTRACTOR PRIOR TO CONSTRUCTION.

SEE DRAINAGE AREA MAP SHEETS FOR DRAINAGE SYMBOLOLOGY.

R/W & U/E PURCHASED UNDER JP 09032(05)

POB & ASSOCIATES, OKLAHOMA CITY, OK.
90% PLAN SUBMITTAL
 3/4/2024

AREA
 CUT FILL

VOLUME
 CUT FILL

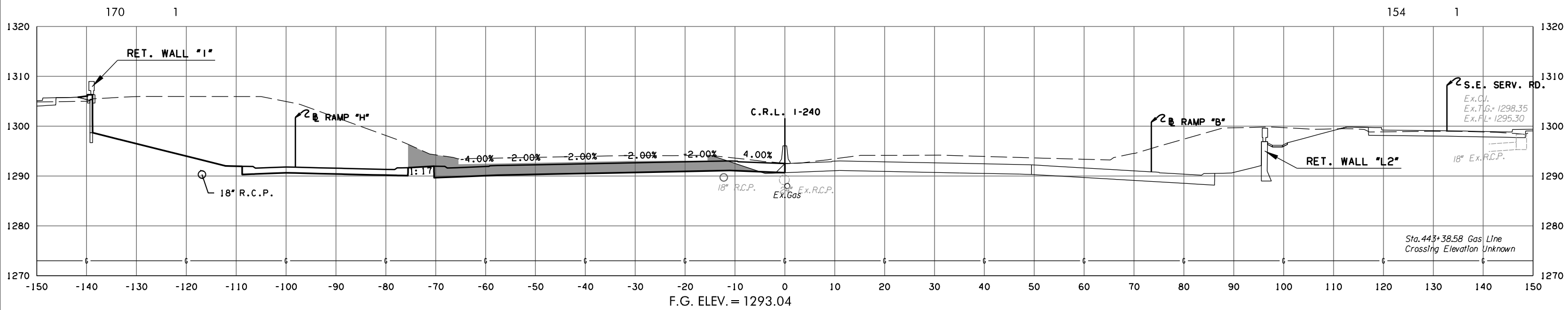

F.G. ELEV. = 1293.04
 A 443 + 38.58

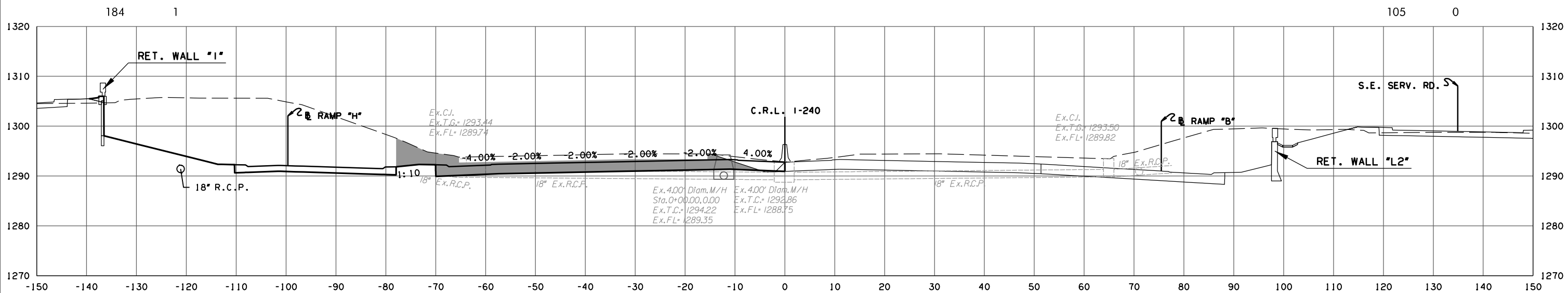

F.G. ELEV. = 1293.30
 A 443 + 15.15

CRL 1-240 W.B. PHASE 4
 STATE JOB NO. 09032(08)
 OKLAHOMA COUNTY SHEET NO. X083

3/4/2024 3:56:28 PM
 H:\PROJECTS\2789_CrossRoads_Phase 4\Roadway\Drawings\Sections\0903208-XSEC-CRL.WB.1-240.dgn

(CAUTION) THE LOCATION OF ALL UTILITIES AS SHOWN ARE APPROXIMATE. DUE TO RELOCATION'S PLANNED OR PRESENTLY UNDER CONSTRUCTION THERE ARE SOME UTILITIES THAT WILL BE RELOCATED AND NOT SHOWN ON THESE PLANS. THE CONTRACTOR SHALL BE RESPONSIBLE FOR ANY DAMAGE TO ALL UTILITIES.
 DEPTH & LOCATION OF EXISTING UTILITIES SHALL BE FIELD VERIFIED BY THE CONTRACTOR PRIOR TO CONSTRUCTION.

SEE DRAINAGE AREA MAP SHEETS FOR DRAINAGE SYMBOLOLOGY.

R/W & U/E PURCHASED UNDER JP 09032(05)

POB & ASSOCIATES, OKLAHOMA CITY, OK.
90% PLAN SUBMITTAL
 3/4/2024

AREA
 CUT FILL

VOLUME
 CUT FILL

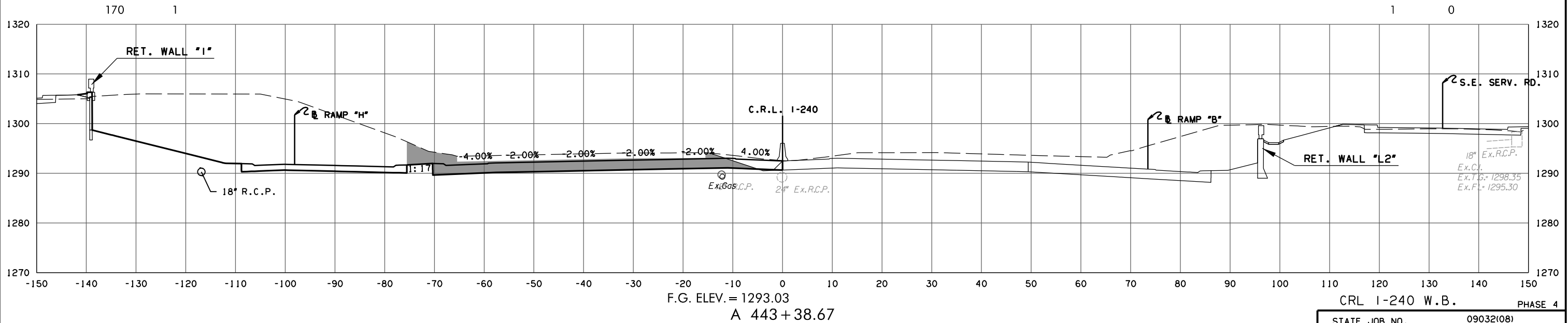
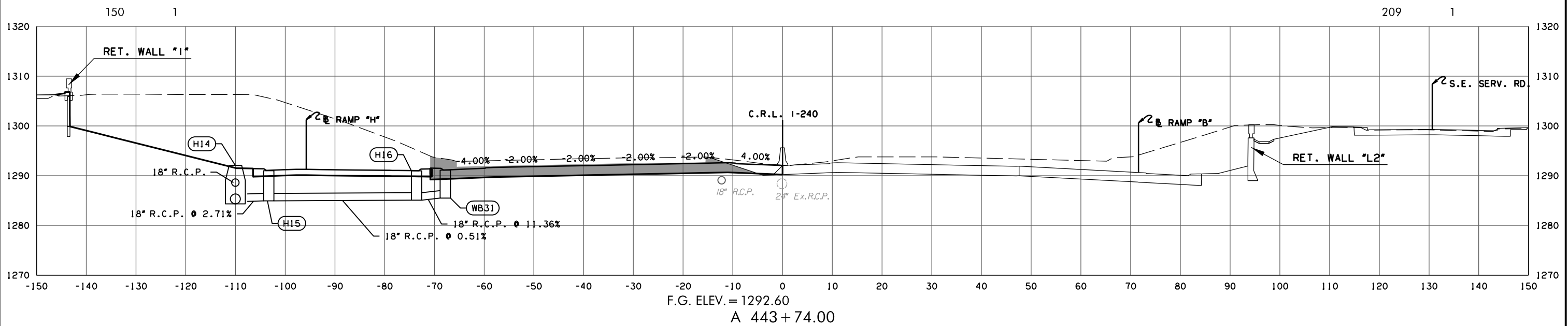

3/4/2024 3:56:29 PM H:\PROJECTS\2789_CrossRoads_Phase 4\Roadway\Drawings\Sections\0903208-XSEC-CRL-WB-1-240.dgn

CRL 1-240 W.B. PHASE 4
 STATE JOB NO. 09032(08)
 OKLAHOMA COUNTY SHEET NO. X084

(CAUTION) THE LOCATION OF ALL UTILITIES AS SHOWN ARE APPROXIMATE. DUE TO RELOCATION'S PLANNED OR PRESENTLY UNDER CONSTRUCTION THERE ARE SOME UTILITIES THAT WILL BE RELOCATED AND NOT SHOWN ON THESE PLANS. THE CONTRACTOR SHALL BE RESPONSIBLE FOR ANY DAMAGE TO ALL UTILITIES. DEPTH & LOCATION OF EXISTING UTILITIES SHALL BE FIELD VERIFIED BY THE CONTRACTOR PRIOR TO CONSTRUCTION.

SEE DRAINAGE AREA MAP SHEETS FOR DRAINAGE SYMBOLOLOGY.

R/W & U/E PURCHASED UNDER JP 09032(05)

POB & ASSOCIATES, OKLAHOMA CITY, OK.
90% PLAN SUBMITTAL
 3/4/2024

AREA
 CUT FILL

VOLUME
 CUT FILL

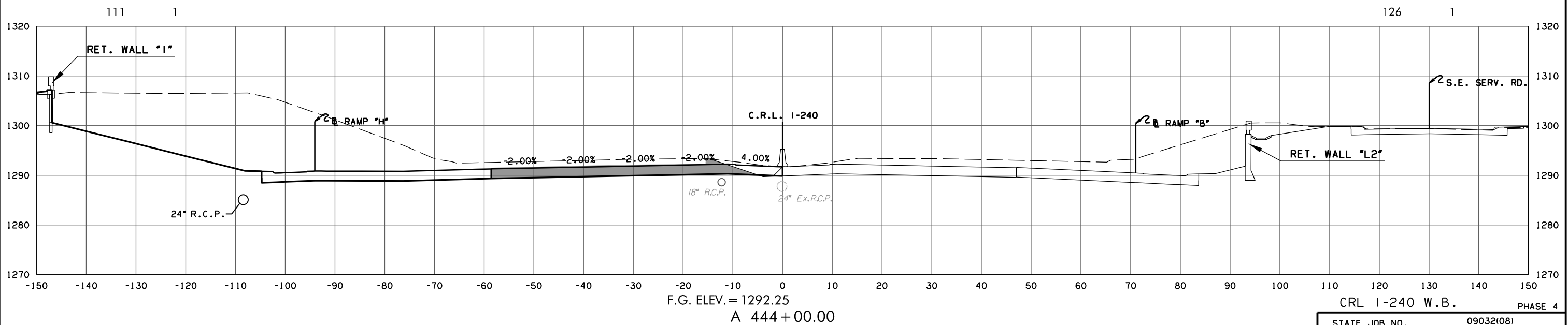
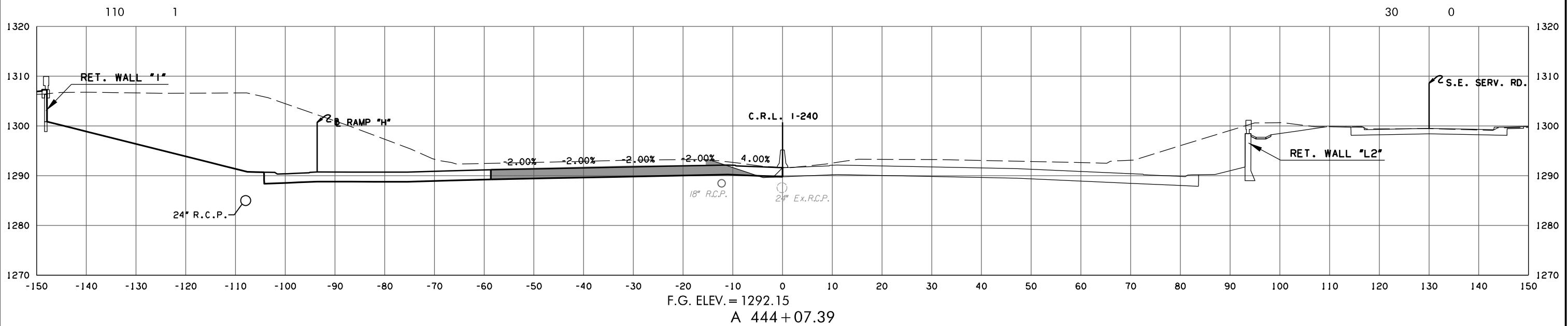

CRL 1-240 W.B. PHASE 4
 STATE JOB NO. 09032(08)
 OKLAHOMA COUNTY SHEET NO. X085

3/4/2024 3:56:31 PM H:\PROJECTS\2789_CrossRoads_Phase 4\Roadway\Drawings\Sections\0903208-XSEC-CRL-WB-1-240.dgn

(CAUTION) THE LOCATION OF ALL UTILITIES AS SHOWN ARE APPROXIMATE. DUE TO RELOCATION'S PLANNED OR PRESENTLY UNDER CONSTRUCTION THERE ARE SOME UTILITIES THAT WILL BE RELOCATED AND NOT SHOWN ON THESE PLANS. THE CONTRACTOR SHALL BE RESPONSIBLE FOR ANY DAMAGE TO ALL UTILITIES.
 DEPTH & LOCATION OF EXISTING UTILITIES SHALL BE FIELD VERIFIED BY THE CONTRACTOR PRIOR TO CONSTRUCTION.

SEE DRAINAGE AREA MAP SHEETS FOR DRAINAGE SYMBOLOLOGY.

R/W & U/E PURCHASED UNDER JP 09032(05)

POB & ASSOCIATES, OKLAHOMA CITY, OK.
90% PLAN SUBMITTAL
 3/4/2024

AREA
 CUT FILL

VOLUME
 CUT FILL

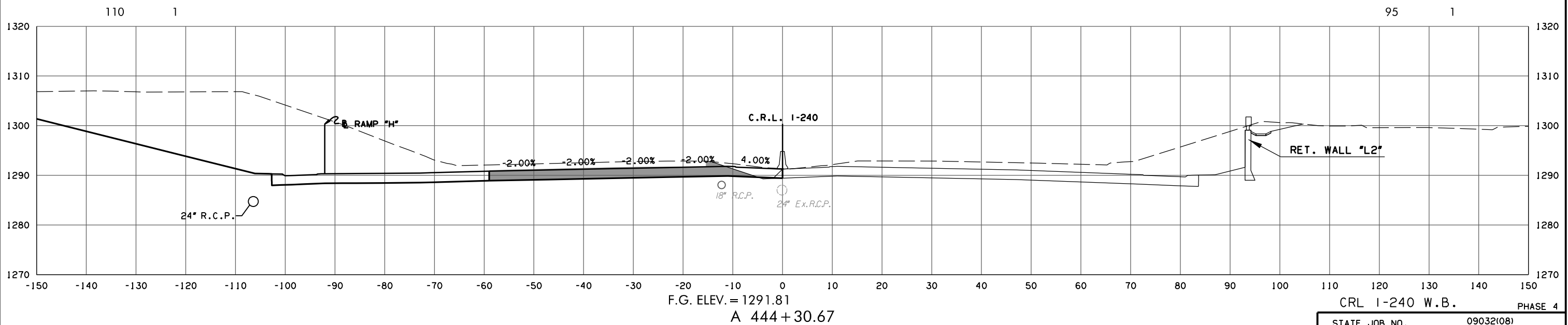
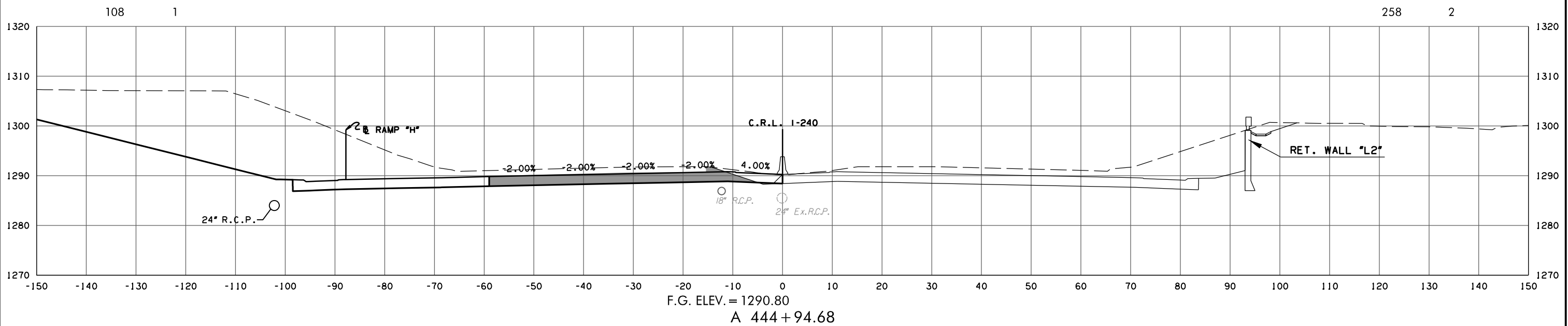

CRL 1-240 W.B. PHASE 4
 STATE JOB NO. 09032(08)
 OKLAHOMA COUNTY SHEET NO. X086

3/4/2024 3:56:33 PM H:\PROJECTS\2789_CrossRoads_Phase 4\Roadway\Drawings\Sections\0903208-XSEC-CRL-WB-1-240.dgn

(CAUTION) THE LOCATION OF ALL UTILITIES AS SHOWN ARE APPROXIMATE. DUE TO RELOCATION'S PLANNED OR PRESENTLY UNDER CONSTRUCTION THERE ARE SOME UTILITIES THAT WILL BE RELOCATED AND NOT SHOWN ON THESE PLANS. THE CONTRACTOR SHALL BE RESPONSIBLE FOR ANY DAMAGE TO ALL UTILITIES. DEPTH & LOCATION OF EXISTING UTILITIES SHALL BE FIELD VERIFIED BY THE CONTRACTOR PRIOR TO CONSTRUCTION.

SEE DRAINAGE AREA MAP SHEETS FOR DRAINAGE SYMBOLOLOGY.

R/W & U/E PURCHASED UNDER JP 09032(05)

POB & ASSOCIATES, OKLAHOMA CITY, OK.
90% PLAN SUBMITTAL
 3/4/2024

AREA
 CUT FILL

VOLUME
 CUT FILL

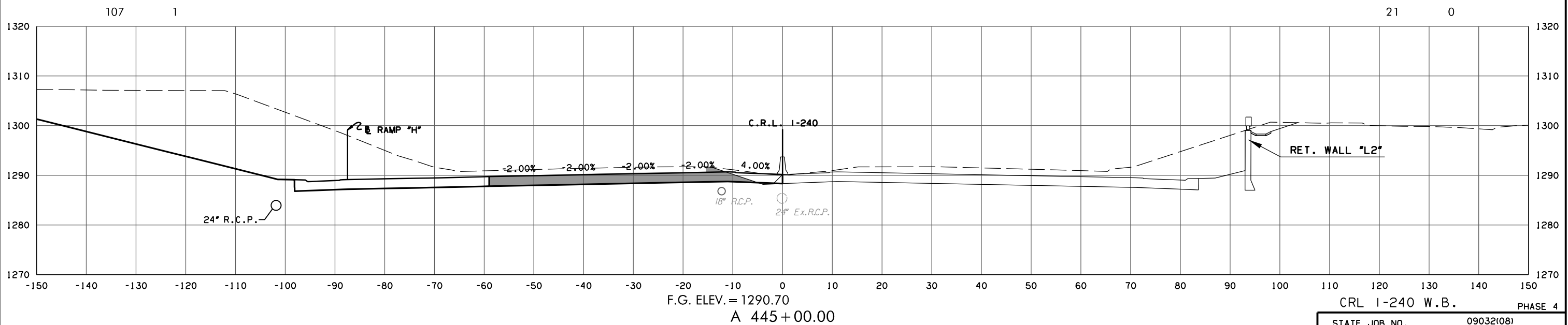
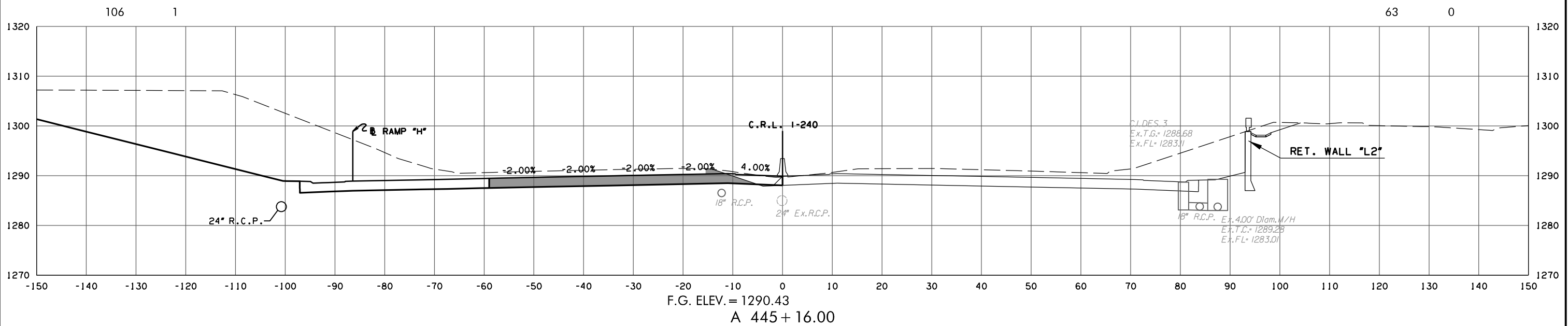

CRL 1-240 W.B. PHASE 4
 STATE JOB NO. 09032(08)
 OKLAHOMA COUNTY SHEET NO. X087

3/4/2024 3:56:34 PM
 H:\PROJECTS\2789_CrossRoads_Phase 4\Roadway\Drawings\Sections\0903208-XSEC.CRL.WB.1-240.dgn

(CAUTION) THE LOCATION OF ALL UTILITIES AS SHOWN ARE APPROXIMATE. DUE TO RELOCATION'S PLANNED OR PRESENTLY UNDER CONSTRUCTION THERE ARE SOME UTILITIES THAT WILL BE RELOCATED AND NOT SHOWN ON THESE PLANS. THE CONTRACTOR SHALL BE RESPONSIBLE FOR ANY DAMAGE TO ALL UTILITIES. DEPTH & LOCATION OF EXISTING UTILITIES SHALL BE FIELD VERIFIED BY THE CONTRACTOR PRIOR TO CONSTRUCTION.

SEE DRAINAGE AREA MAP SHEETS FOR DRAINAGE SYMBOLOLOGY.

R/W & U/E PURCHASED UNDER JP 09032(05)

POB & ASSOCIATES, OKLAHOMA CITY, OK.
90% PLAN SUBMITTAL
 3/4/2024

AREA
 CUT FILL

VOLUME
 CUT FILL

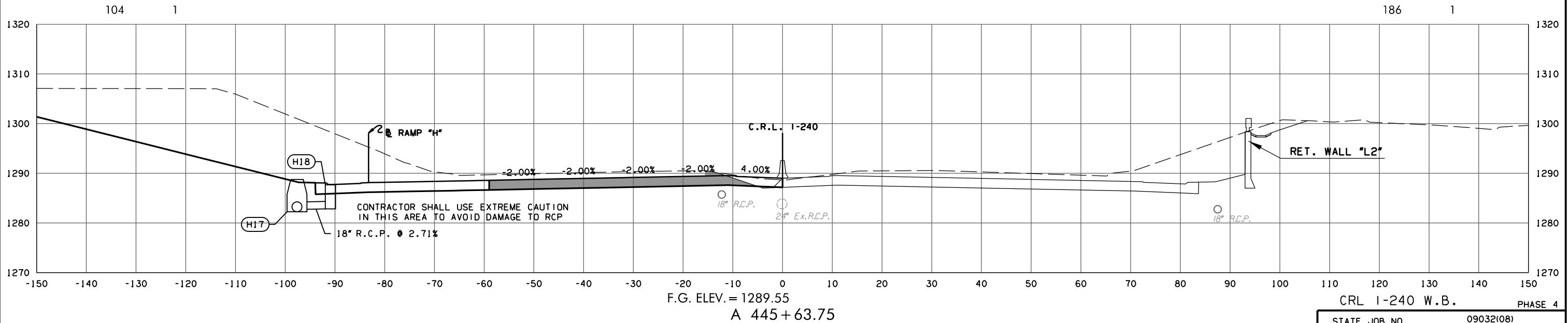
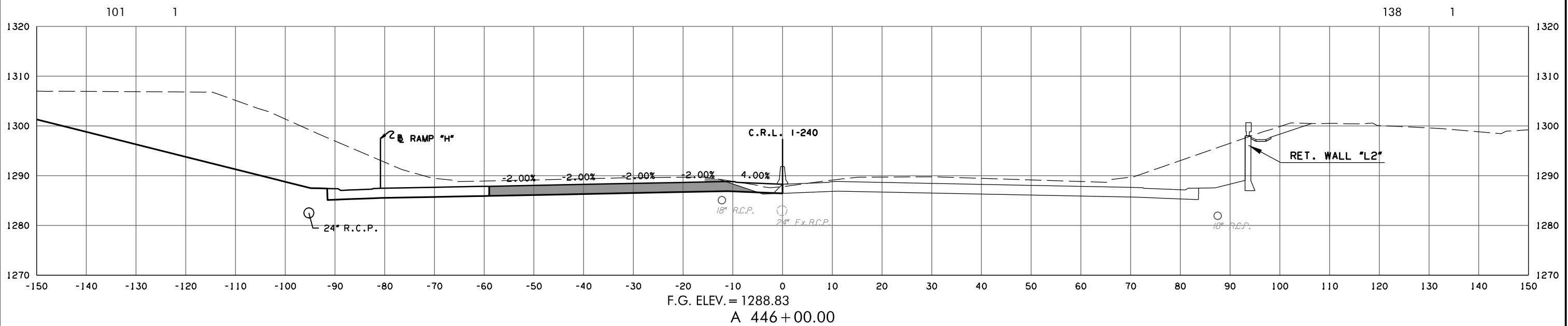

3/4/2024 3:56:36 PM H:\PROJECTS\2789_CrossRoads_Phase 4\Roadway\Drawings\Sections\0903208-XSEC-CRL-WB-I-240.dgn

CRL I-240 W.B. PHASE 4
 STATE JOB NO. 09032(08)
 OKLAHOMA COUNTY SHEET NO. X088

(CAUTION) THE LOCATION OF ALL UTILITIES AS SHOWN ARE APPROXIMATE. DUE TO RELOCATION'S PLANNED OR PRESENTLY UNDER CONSTRUCTION THERE ARE SOME UTILITIES THAT WILL BE RELOCATED AND NOT SHOWN ON THESE PLANS. THE CONTRACTOR SHALL BE RESPONSIBLE FOR ANY DAMAGE TO ALL UTILITIES. DEPTH & LOCATION OF EXISTING UTILITIES SHALL BE FIELD VERIFIED BY THE CONTRACTOR PRIOR TO CONSTRUCTION.

SEE DRAINAGE AREA MAP SHEETS FOR DRAINAGE SYMBOLOLOGY.

R/W & U/E PURCHASED UNDER JP 09032(05)

POB & ASSOCIATES, OKLAHOMA CITY, OK.
90% PLAN SUBMITTAL
 3/4/2024

AREA
 CUT FILL

VOLUME
 CUT FILL

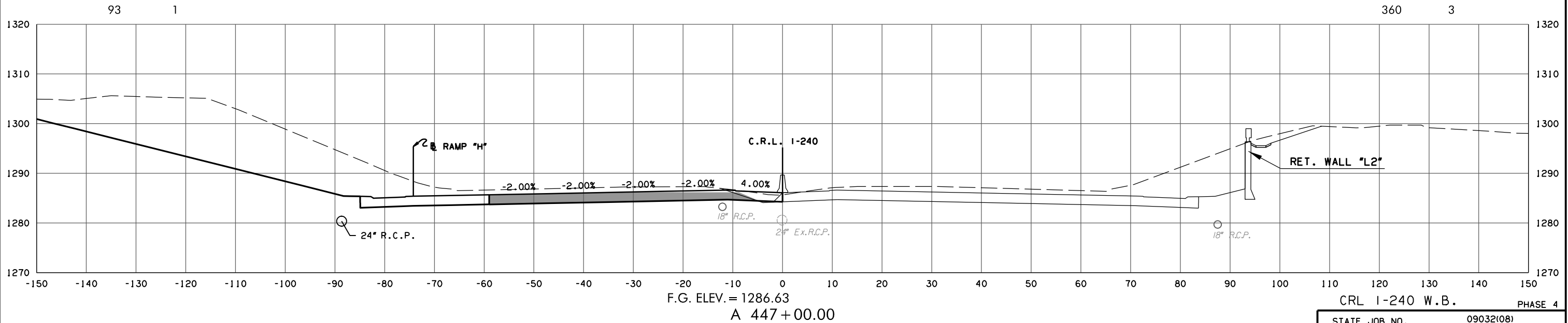
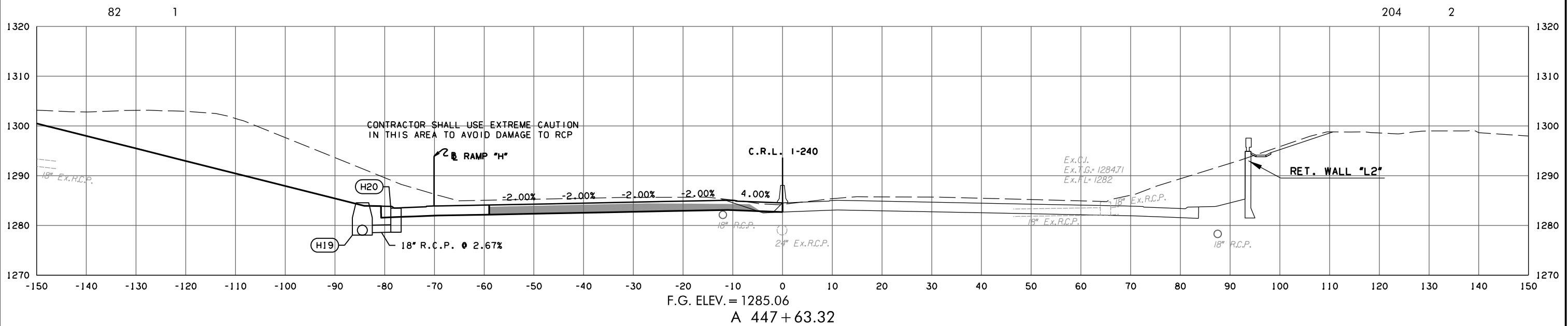

3/4/2024 3:56:38 PM H:\PROJECTS\2789_CrossRoads_Phase 4\Roadway\Drawings\Sections\0903208-XSEC-CRL-WB-I-240.dgn

CRL 1-240 W.B. PHASE 4
 STATE JOB NO. 09032(08)
 OKLAHOMA COUNTY SHEET NO. X089

(CAUTION) THE LOCATION OF ALL UTILITIES AS SHOWN ARE APPROXIMATE. DUE TO RELOCATION'S PLANNED OR PRESENTLY UNDER CONSTRUCTION THERE ARE SOME UTILITIES THAT WILL BE RELOCATED AND NOT SHOWN ON THESE PLANS. THE CONTRACTOR SHALL BE RESPONSIBLE FOR ANY DAMAGE TO ALL UTILITIES.
 DEPTH & LOCATION OF EXISTING UTILITIES SHALL BE FIELD VERIFIED BY THE CONTRACTOR PRIOR TO CONSTRUCTION.

SEE DRAINAGE AREA MAP SHEETS FOR DRAINAGE SYMBOLOLOGY.

R/W & U/E PURCHASED UNDER JP 09032(05)

POB & ASSOCIATES, OKLAHOMA CITY, OK.
90% PLAN SUBMITTAL
 3/4/2024

AREA
 CUT FILL

VOLUME
 CUT FILL

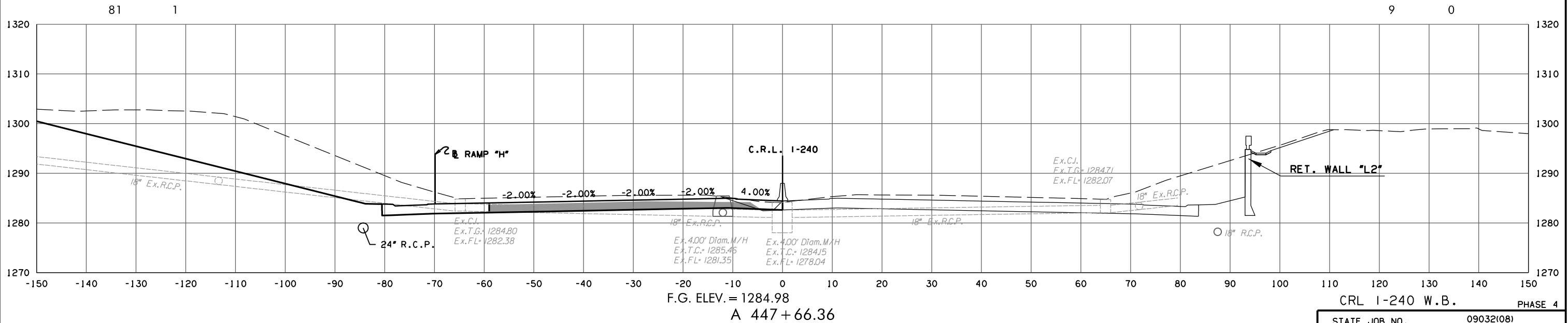
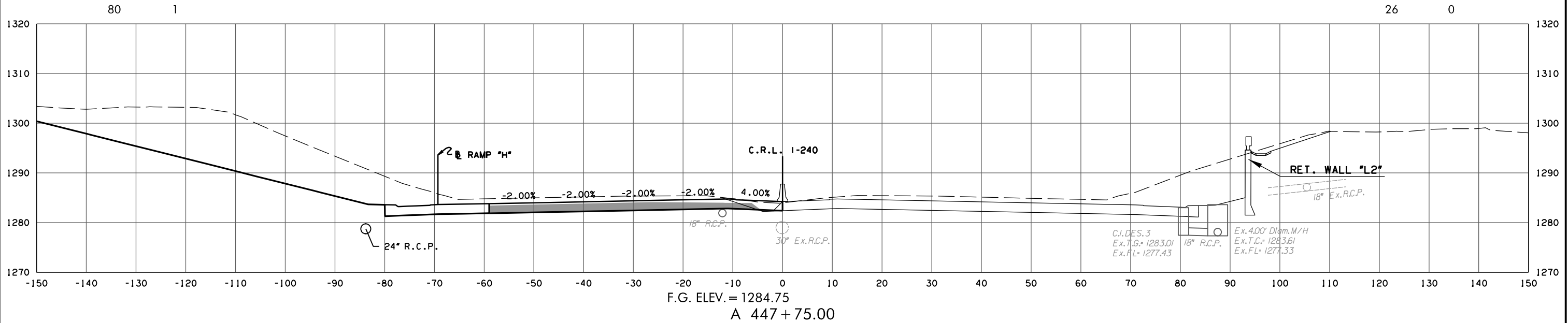

CRL 1-240 W.B. PHASE 4
 STATE JOB NO. 09032(08)
 OKLAHOMA COUNTY SHEET NO. X090

3/4/2024 3:56:39 PM H:\PROJECTS\2789_CrossRoads_Phase 4\Roadway\Drawings\Sections\0903208-XSEC-CRL-WB-1-240.dgn

(CAUTION) THE LOCATION OF ALL UTILITIES AS SHOWN ARE APPROXIMATE. DUE TO RELOCATION'S PLANNED OR PRESENTLY UNDER CONSTRUCTION THERE ARE SOME UTILITIES THAT WILL BE RELOCATED AND NOT SHOWN ON THESE PLANS. THE CONTRACTOR SHALL BE RESPONSIBLE FOR ANY DAMAGE TO ALL UTILITIES. DEPTH & LOCATION OF EXISTING UTILITIES SHALL BE FIELD VERIFIED BY THE CONTRACTOR PRIOR TO CONSTRUCTION.

SEE DRAINAGE AREA MAP SHEETS FOR DRAINAGE SYMBOLOLOGY.

R/W & U/E PURCHASED UNDER JP 09032(05)

POB & ASSOCIATES, OKLAHOMA CITY, OK.

**90% PLAN
SUBMITTAL**

3/4/2024

AREA
CUT FILL

VOLUME
CUT FILL

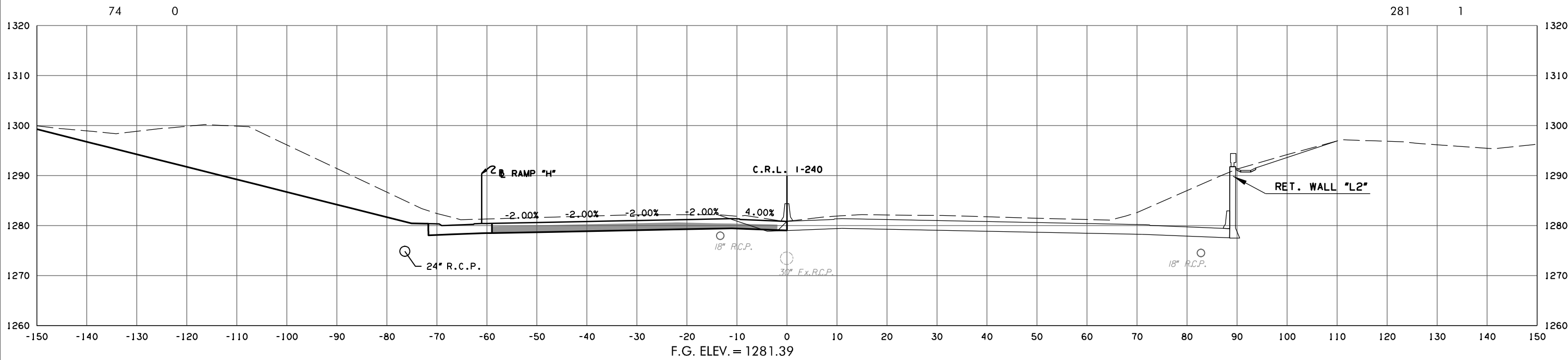

F.G. ELEV. = 1281.39
A 449 + 00.00

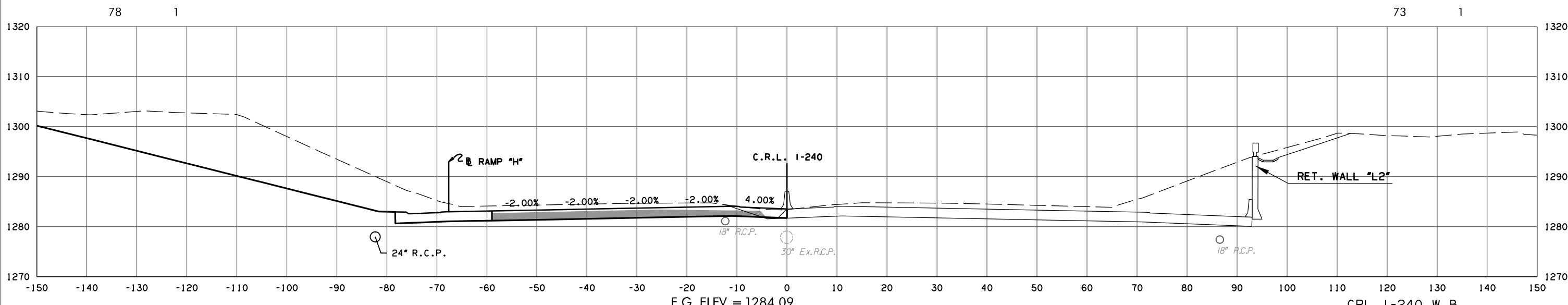

F.G. ELEV. = 1284.09
A 448 + 00.00

CRL 1-240 W.B. PHASE 4

STATE JOB NO. 09032(08)
OKLAHOMA COUNTY SHEET NO. X091

3/4/2024 3:56:41 PM H:\PROJECTS\2789_CrossRoads_Phase 4\Roadway\Drawings\Sections\0903208-XSEC-CRL-WB-1-240.dgn

(CAUTION) THE LOCATION OF ALL UTILITIES AS SHOWN ARE APPROXIMATE. DUE TO RELOCATION'S PLANNED OR PRESENTLY UNDER CONSTRUCTION THERE ARE SOME UTILITIES THAT WILL BE RELOCATED AND NOT SHOWN ON THESE PLANS. THE CONTRACTOR SHALL BE RESPONSIBLE FOR ANY DAMAGE TO ALL UTILITIES. DEPTH & LOCATION OF EXISTING UTILITIES SHALL BE FIELD VERIFIED BY THE CONTRACTOR PRIOR TO CONSTRUCTION.

SEE DRAINAGE AREA MAP SHEETS FOR DRAINAGE SYMBOLOLOGY.

R/W & U/E PURCHASED UNDER JP 09032(05)

POB & ASSOCIATES, OKLAHOMA CITY, OK.
90% PLAN SUBMITTAL
 3/4/2024

AREA
 CUT FILL

VOLUME
 CUT FILL

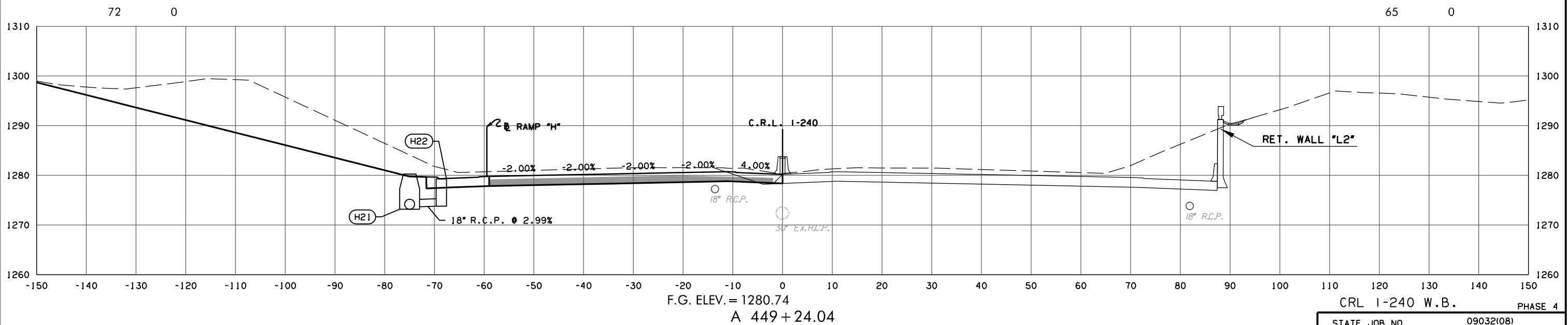
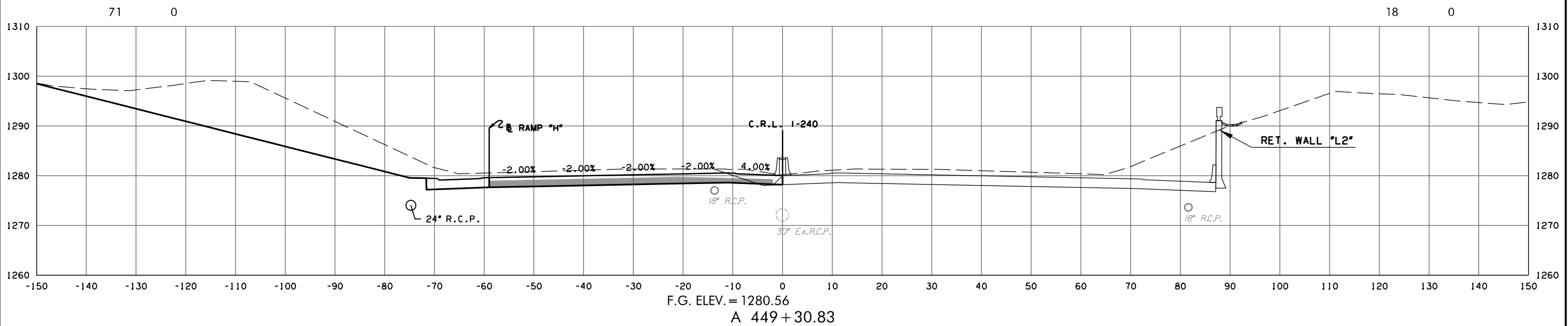

CRL 1-240 W.B. PHASE 4
 STATE JOB NO. 09032(08)
 OKLAHOMA COUNTY SHEET NO. X092

3/4/2024 3:56:43 PM H:\PROJECTS\2789_CrossRoads_Phase 4\Roadway\Drawings\Sections\0903208-XSEC-CRL-WB-1-240.dgn

(CAUTION) THE LOCATION OF ALL UTILITIES AS SHOWN ARE APPROXIMATE. DUE TO RELOCATION'S PLANNED OR PRESENTLY UNDER CONSTRUCTION THERE ARE SOME UTILITIES THAT WILL BE RELOCATED AND NOT SHOWN ON THESE PLANS. THE CONTRACTOR SHALL BE RESPONSIBLE FOR ANY DAMAGE TO ALL UTILITIES.
 DEPTH & LOCATION OF EXISTING UTILITIES SHALL BE FIELD VERIFIED BY THE CONTRACTOR PRIOR TO CONSTRUCTION.

SEE DRAINAGE AREA MAP SHEETS FOR DRAINAGE SYMBOLOLOGY.

R/W & U/E PURCHASED UNDER JP 09032(05)

POB & ASSOCIATES, OKLAHOMA CITY, OK.
90% PLAN SUBMITTAL
 3/4/2024

AREA
 CUT FILL

VOLUME
 CUT FILL

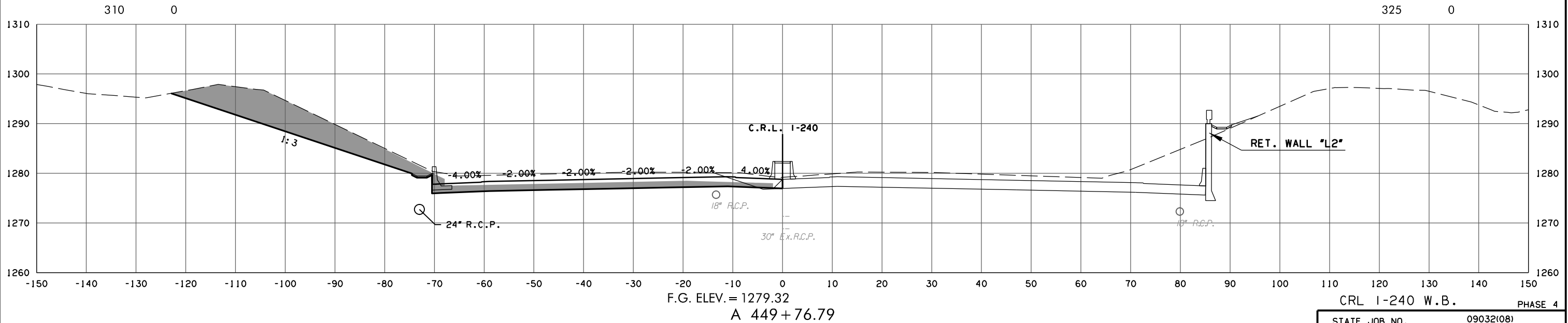
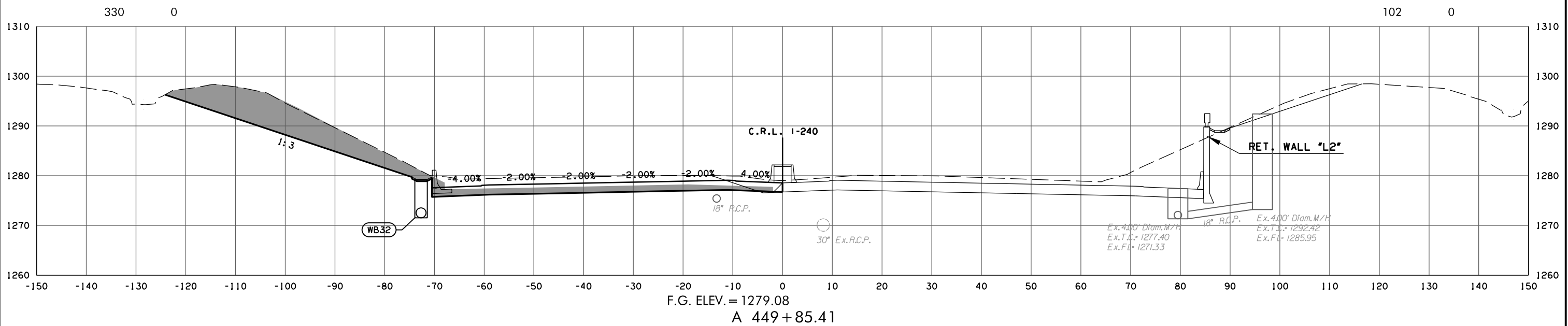

3/4/2024 3:56:45 PM H:\PROJECTS\2789_CrossRoads_Phase 4\Roadway\Drawings\Sections\0903208-XSEC-CRL-WB-I-240.dgn

CRL I-240 W.B. PHASE 4
 STATE JOB NO. 09032(08)
 OKLAHOMA COUNTY SHEET NO. X093

(CAUTION) THE LOCATION OF ALL UTILITIES AS SHOWN ARE APPROXIMATE. DUE TO RELOCATION'S PLANNED OR PRESENTLY UNDER CONSTRUCTION THERE ARE SOME UTILITIES THAT WILL BE RELOCATED AND NOT SHOWN ON THESE PLANS. THE CONTRACTOR SHALL BE RESPONSIBLE FOR ANY DAMAGE TO ALL UTILITIES.
 DEPTH & LOCATION OF EXISTING UTILITIES SHALL BE FIELD VERIFIED BY THE CONTRACTOR PRIOR TO CONSTRUCTION.

SEE DRAINAGE AREA MAP SHEETS FOR DRAINAGE SYMBOLOLOGY.

R/W & U/E PURCHASED UNDER JP 09032(05)

POB & ASSOCIATES, OKLAHOMA CITY, OK.
90% PLAN SUBMITTAL
 3/4/2024

AREA
 CUT FILL

VOLUME
 CUT FILL

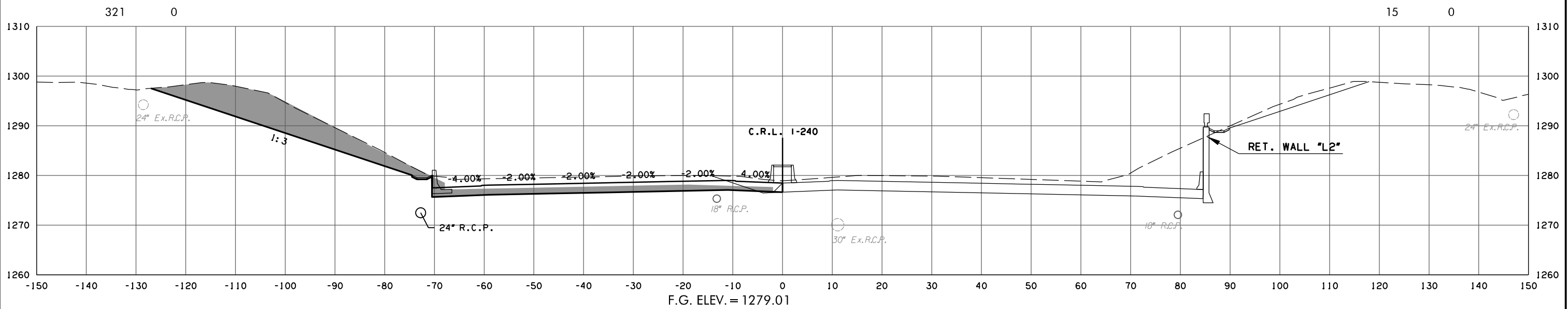

F.G. ELEV. = 1279.01
 A 449 + 88.23

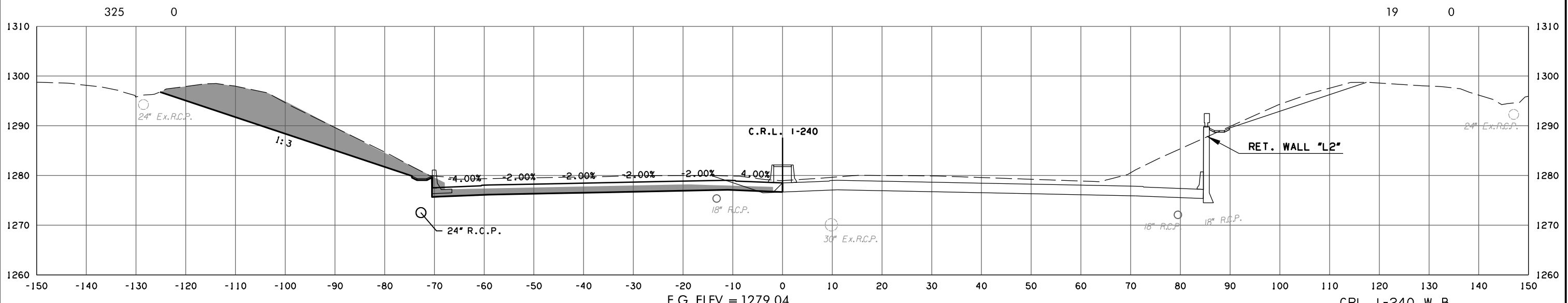

F.G. ELEV. = 1279.04
 A 449 + 87.00

CRL 1-240 W.B. PHASE 4

STATE JOB NO. 09032(08)
 OKLAHOMA COUNTY SHEET NO. X094

3/4/2024 3:56:46 PM H:\PROJECTS\2789_CrossRoads_Phase 4\Roadway\Drawings\Sections\0903208-XSEC-CRL-WB-1-240.dgn

(CAUTION) THE LOCATION OF ALL UTILITIES AS SHOWN ARE APPROXIMATE. DUE TO RELOCATION'S PLANNED OR PRESENTLY UNDER CONSTRUCTION THERE ARE SOME UTILITIES THAT WILL BE RELOCATED AND NOT SHOWN ON THESE PLANS. THE CONTRACTOR SHALL BE RESPONSIBLE FOR ANY DAMAGE TO ALL UTILITIES. DEPTH & LOCATION OF EXISTING UTILITIES SHALL BE FIELD VERIFIED BY THE CONTRACTOR PRIOR TO CONSTRUCTION.

SEE DRAINAGE AREA MAP SHEETS FOR DRAINAGE SYMBOLOLOGY.

R/W & U/E PURCHASED UNDER JP 09032(05)

POB & ASSOCIATES, OKLAHOMA CITY, OK.

**90% PLAN
SUBMITTAL**

3/4/2024

AREA
CUT FILL

VOLUME
CUT FILL

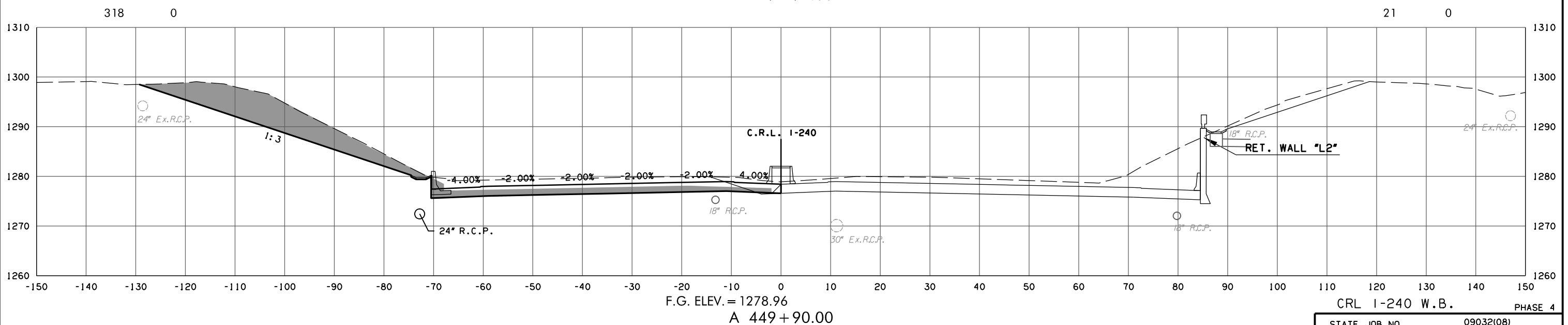
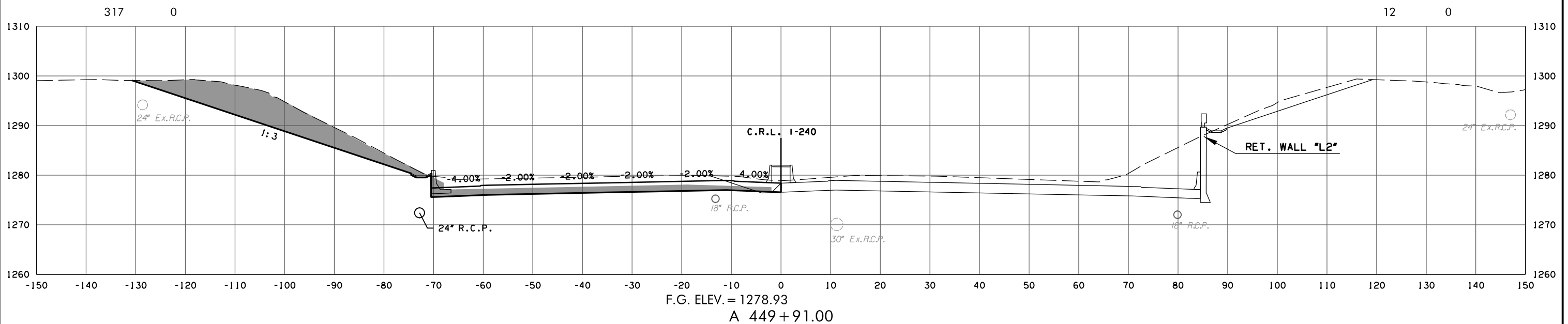

CRL 1-240 W.B. PHASE 4

STATE JOB NO. 09032(08)
OKLAHOMA COUNTY SHEET NO. X095

3/4/2024 3:56:48 PM H:\PROJECTS\2789_CrossRoads_Phase 4\Roadway\Drawings\Sections\0903208-XSEC-CRL-WB-1-240.dgn

(CAUTION) THE LOCATION OF ALL UTILITIES AS SHOWN ARE APPROXIMATE. DUE TO RELOCATION'S PLANNED OR PRESENTLY UNDER CONSTRUCTION THERE ARE SOME UTILITIES THAT WILL BE RELOCATED AND NOT SHOWN ON THESE PLANS. THE CONTRACTOR SHALL BE RESPONSIBLE FOR ANY DAMAGE TO ALL UTILITIES.

DEPTH & LOCATION OF EXISTING UTILITIES SHALL BE FIELD VERIFIED BY THE CONTRACTOR PRIOR TO CONSTRUCTION.

SEE DRAINAGE AREA MAP SHEETS FOR DRAINAGE SYMBOLOLOGY.

R/W & U/E PURCHASED UNDER JP 09032(05)

POB & ASSOCIATES, OKLAHOMA CITY, OK.

**90% PLAN
SUBMITTAL**

3/4/2024

AREA
CUT FILL

VOLUME
CUT FILL

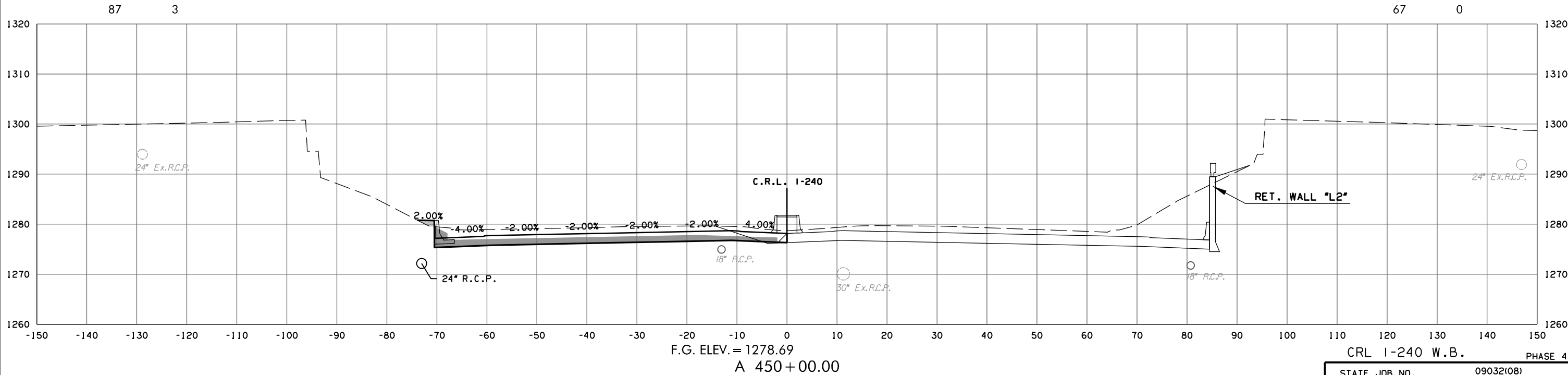
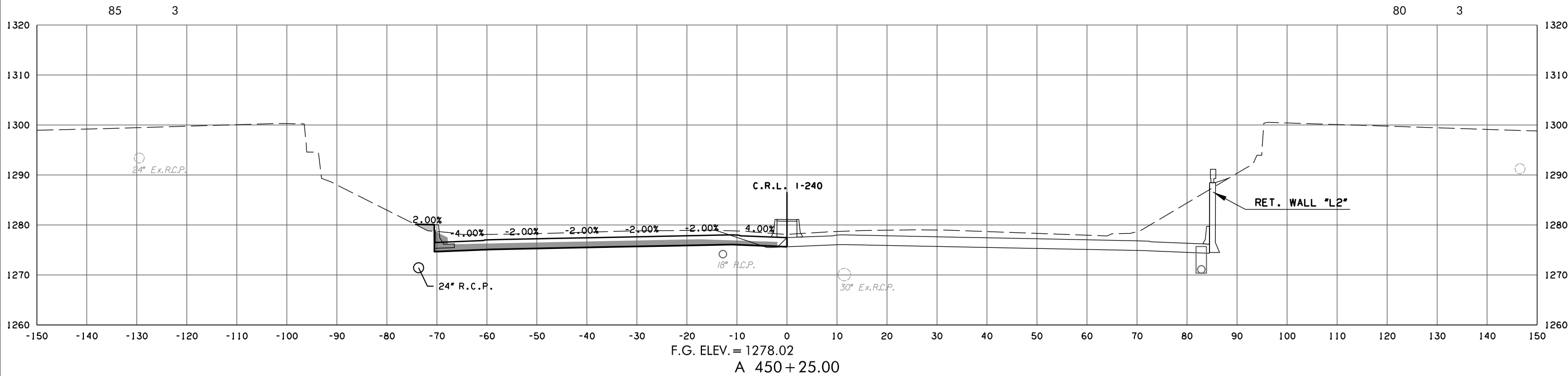

CRL 1-240 W.B. PHASE 4
STATE JOB NO. 09032(08)
OKLAHOMA COUNTY SHEET NO. X096

3/4/2024 3:56:50 PM H:\PROJECTS\2789_CrossRoads_Phase 4\Roadway\Drawings\Sections\0903208-XSEC_CRL_WB_1-240.dgn

(CAUTION) THE LOCATION OF ALL UTILITIES AS SHOWN ARE APPROXIMATE. DUE TO RELOCATION'S PLANNED OR PRESENTLY UNDER CONSTRUCTION THERE ARE SOME UTILITIES THAT WILL BE RELOCATED AND NOT SHOWN ON THESE PLANS. THE CONTRACTOR SHALL BE RESPONSIBLE FOR ANY DAMAGE TO ALL UTILITIES.
 DEPTH & LOCATION OF EXISTING UTILITIES SHALL BE FIELD VERIFIED BY THE CONTRACTOR PRIOR TO CONSTRUCTION.

SEE DRAINAGE AREA MAP SHEETS FOR DRAINAGE SYMBOLOLOGY.

R/W & U/E PURCHASED UNDER JP 09032(05)

POB & ASSOCIATES, OKLAHOMA CITY, OK.
90% PLAN SUBMITTAL
 3/4/2024

AREA
 CUT FILL

VOLUME
 CUT FILL

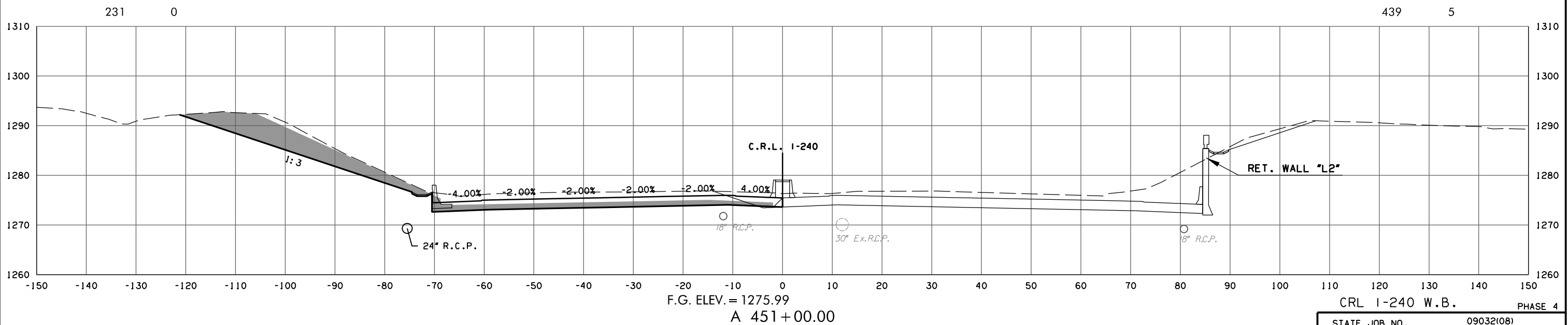
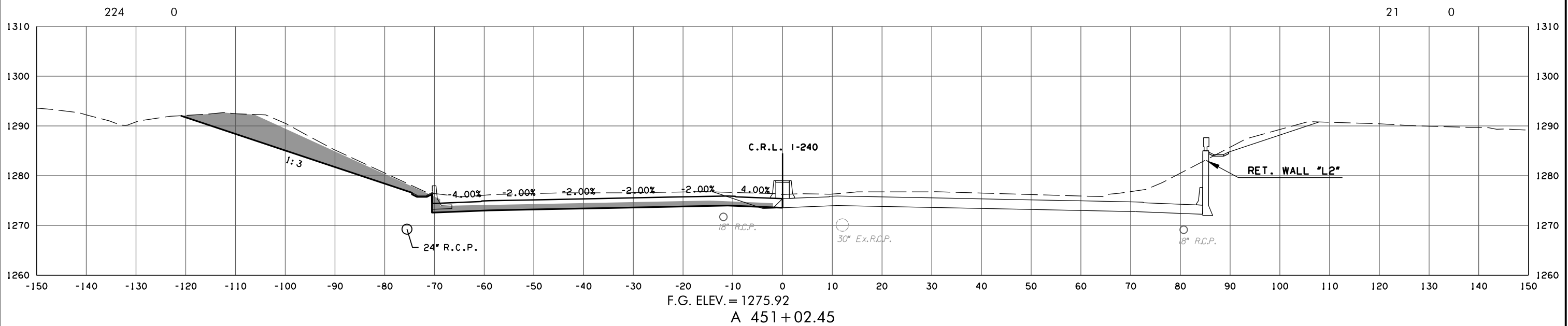

CRL 1-240 W.B. PHASE 4
 STATE JOB NO. 09032(08)
 OKLAHOMA COUNTY SHEET NO. X097

3/4/2024 3:56:52 PM
 H:\PROJECTS\2789_CrossRoads_Phase 4\Roadway\Drawings\Sections\0903208-XSEC.CRL.WB.1-240.dgn

(CAUTION) THE LOCATION OF ALL UTILITIES AS SHOWN ARE APPROXIMATE. DUE TO RELOCATION'S PLANNED OR PRESENTLY UNDER CONSTRUCTION THERE ARE SOME UTILITIES THAT WILL BE RELOCATED AND NOT SHOWN ON THESE PLANS. THE CONTRACTOR SHALL BE RESPONSIBLE FOR ANY DAMAGE TO ALL UTILITIES.
 DEPTH & LOCATION OF EXISTING UTILITIES SHALL BE FIELD VERIFIED BY THE CONTRACTOR PRIOR TO CONSTRUCTION.

SEE DRAINAGE AREA MAP SHEETS FOR DRAINAGE SYMBOLOLOGY.

R/W & U/E PURCHASED UNDER JP 09032(05)

POB & ASSOCIATES, OKLAHOMA CITY, OK.

90% PLAN SUBMITTAL

3/4/2024

AREA
 CUT FILL

VOLUME
 CUT FILL

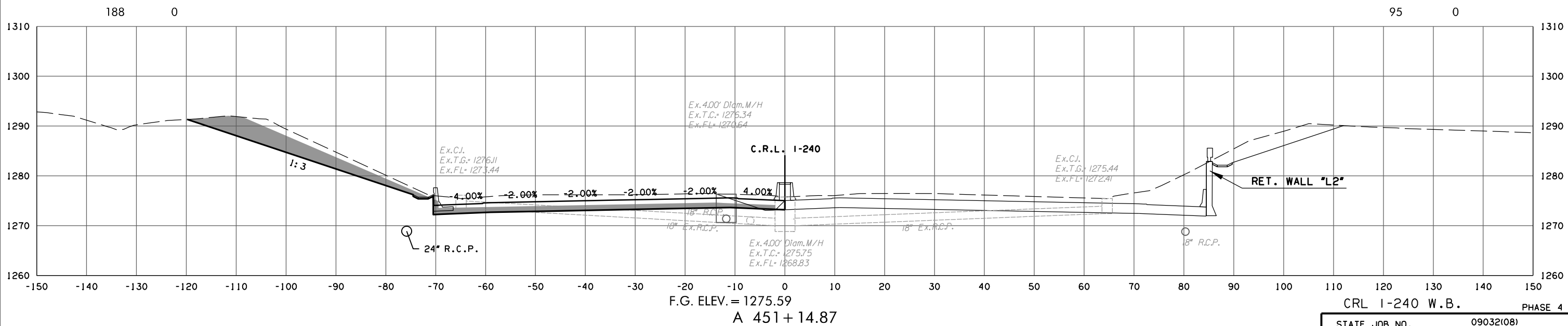
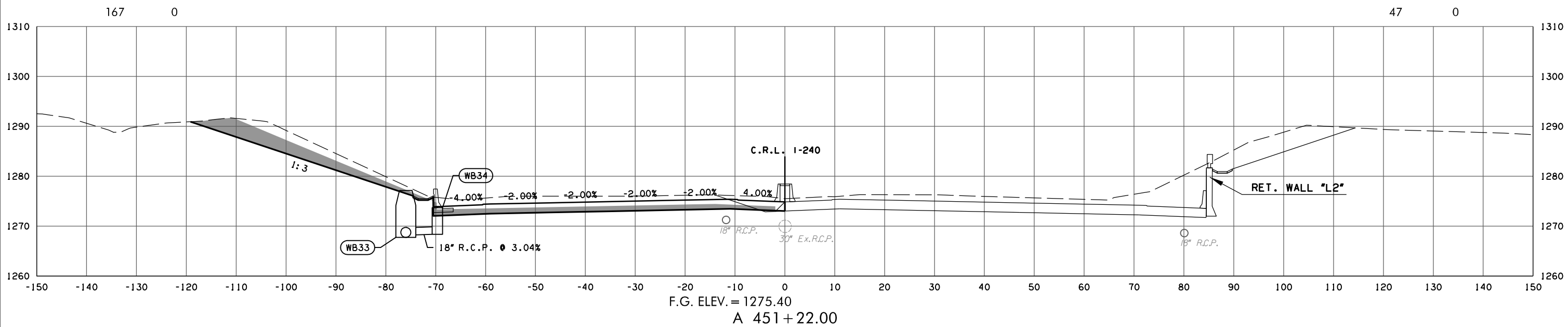

3/4/2024 3:56:53 PM H:\PROJECTS\2789_CrossRoads_Phase 4\Roadway\Drawings\Sections\0903208-XSEC.CRL.WB.1-240.dgn

(CAUTION) THE LOCATION OF ALL UTILITIES AS SHOWN ARE APPROXIMATE. DUE TO RELOCATION'S PLANNED OR PRESENTLY UNDER CONSTRUCTION THERE ARE SOME UTILITIES THAT WILL BE RELOCATED AND NOT SHOWN ON THESE PLANS. THE CONTRACTOR SHALL BE RESPONSIBLE FOR ANY DAMAGE TO ALL UTILITIES.
 DEPTH & LOCATION OF EXISTING UTILITIES SHALL BE FIELD VERIFIED BY THE CONTRACTOR PRIOR TO CONSTRUCTION.

SEE DRAINAGE AREA MAP SHEETS FOR DRAINAGE SYMBOLOLOGY.

R/W & U/E PURCHASED UNDER JP 09032(105)

POB & ASSOCIATES, OKLAHOMA CITY, OK.
90% PLAN SUBMITTAL
 3/4/2024

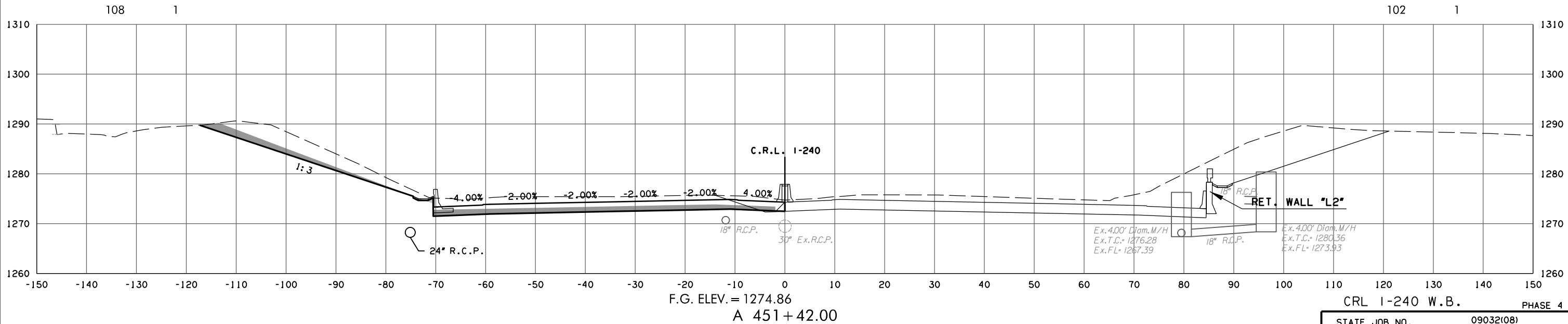
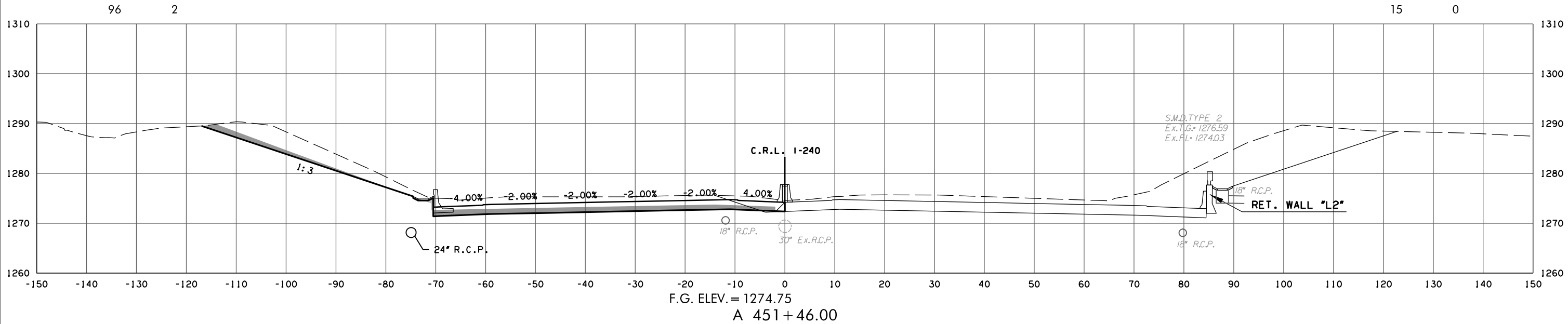
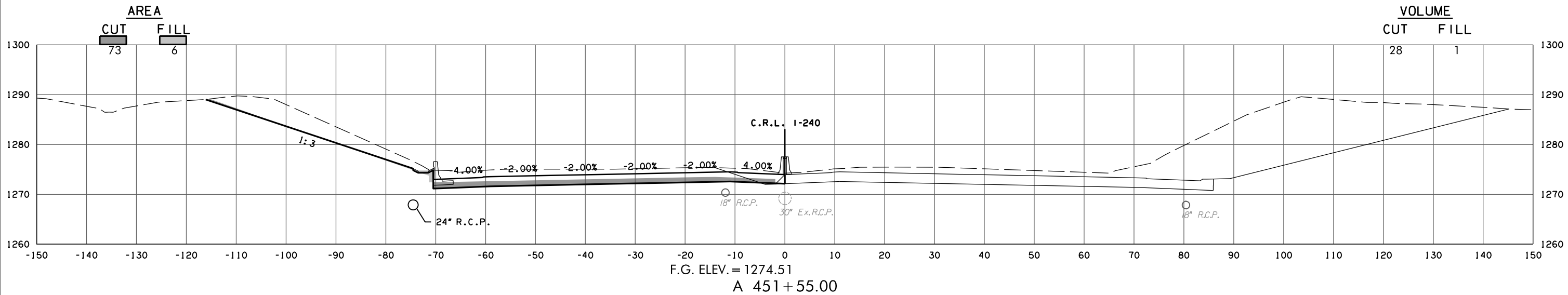

CRL 1-240 W.B. PHASE 4
 STATE JOB NO. 09032(108)
 OKLAHOMA COUNTY SHEET NO. X099

3/4/2024 3:56:55 PM H:\PROJECTS\2789_CrossRoads_Phase 4\Roadway\Drawings\Sections\0903208-XSEC.CRL.WB.1-240.dgn

(CAUTION) THE LOCATION OF ALL UTILITIES AS SHOWN ARE APPROXIMATE. DUE TO RELOCATION'S PLANNED OR PRESENTLY UNDER CONSTRUCTION THERE ARE SOME UTILITIES THAT WILL BE RELOCATED AND NOT SHOWN ON THESE PLANS. THE CONTRACTOR SHALL BE RESPONSIBLE FOR ANY DAMAGE TO ALL UTILITIES.
 DEPTH & LOCATION OF EXISTING UTILITIES SHALL BE FIELD VERIFIED BY THE CONTRACTOR PRIOR TO CONSTRUCTION.

SEE DRAINAGE AREA MAP SHEETS FOR DRAINAGE SYMBOLOLOGY.

R/W & U/E PURCHASED UNDER JP 09032(05)

POB & ASSOCIATES, OKLAHOMA CITY, OK.
90% PLAN SUBMITTAL
 3/4/2024

AREA
 CUT FILL

VOLUME
 CUT FILL

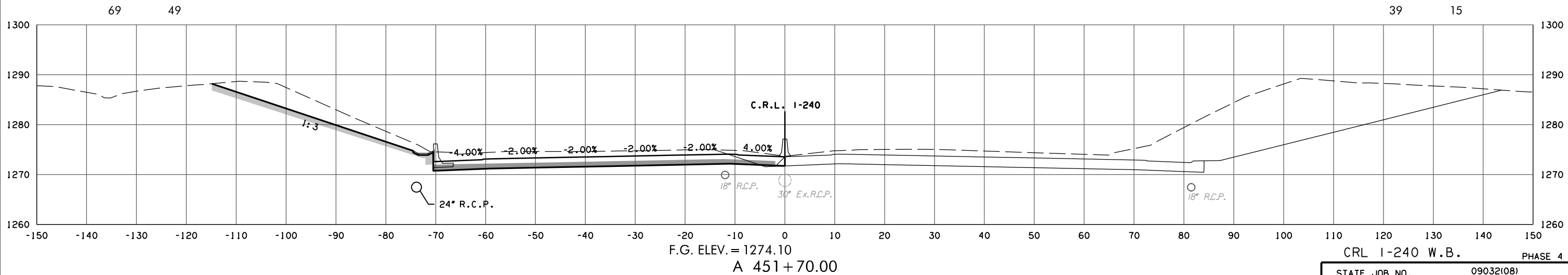
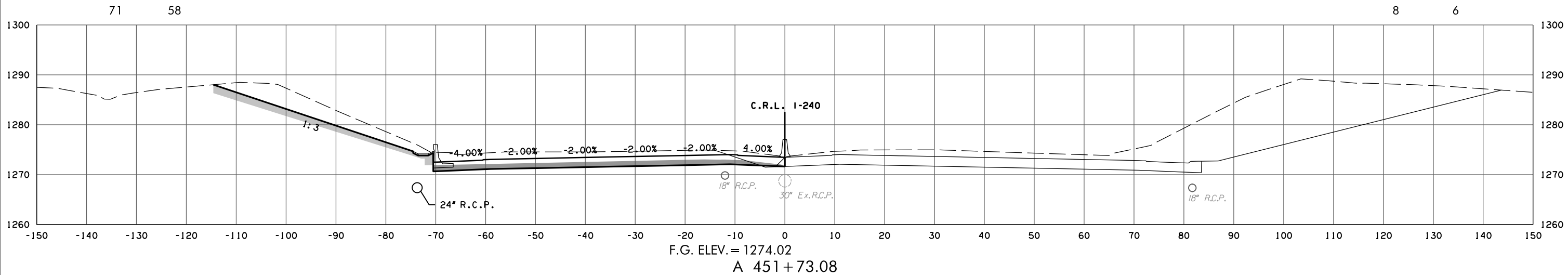
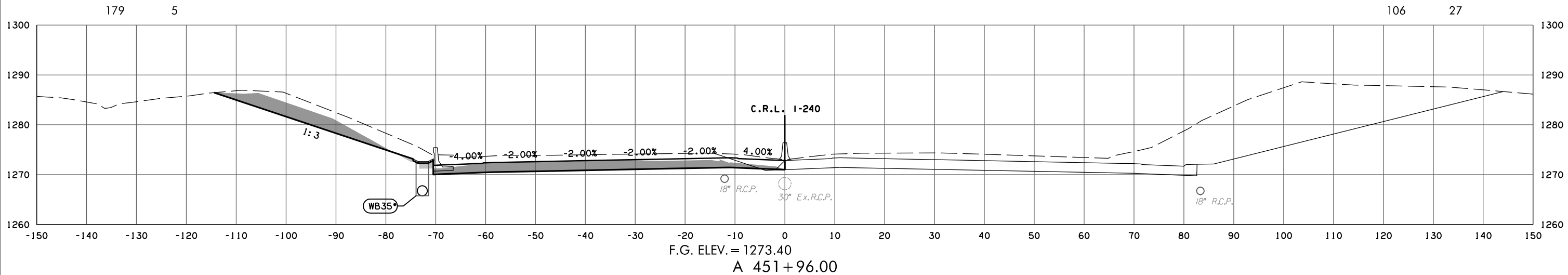

CRL 1-240 W.B. PHASE 4
 STATE JOB NO. 09032(08)
 OKLAHOMA COUNTY SHEET NO. X100

3/4/2024 3:56:57 PM
 H:\PROJECTS\2789_CrossRoads_Phase 4\Roadway\Drawings\Sections\0903208-XSEC.CRL.WB.1-240.dgn

(CAUTION) THE LOCATION OF ALL UTILITIES AS SHOWN ARE APPROXIMATE. DUE TO RELOCATION'S PLANNED OR PRESENTLY UNDER CONSTRUCTION THERE ARE SOME UTILITIES THAT WILL BE RELOCATED AND NOT SHOWN ON THESE PLANS. THE CONTRACTOR SHALL BE RESPONSIBLE FOR ANY DAMAGE TO ALL UTILITIES.
 DEPTH & LOCATION OF EXISTING UTILITIES SHALL BE FIELD VERIFIED BY THE CONTRACTOR PRIOR TO CONSTRUCTION.

SEE DRAINAGE AREA MAP SHEETS FOR DRAINAGE SYMBOLOLOGY.

R/W & U/E PURCHASED UNDER JP 09032(05)

POB & ASSOCIATES, OKLAHOMA CITY, OK.
90% PLAN
SUBMITTAL
 3/4/2024

AREA
 CUT FILL

VOLUME
 CUT FILL

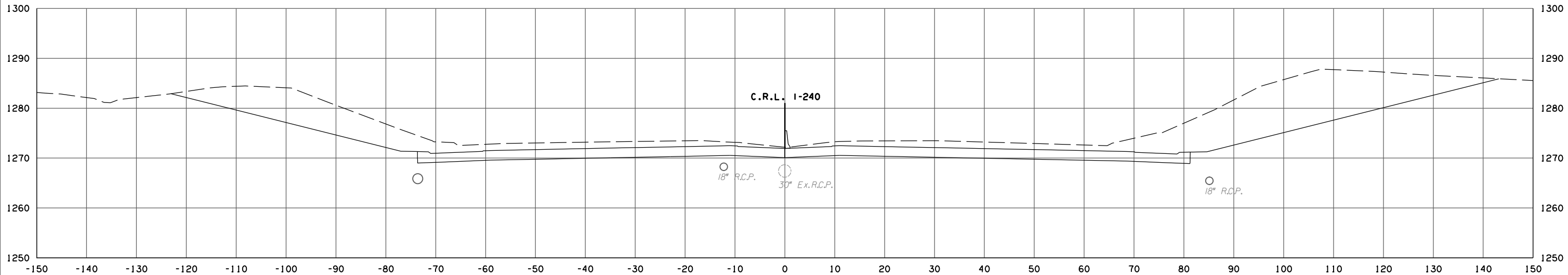

A 452+30.00

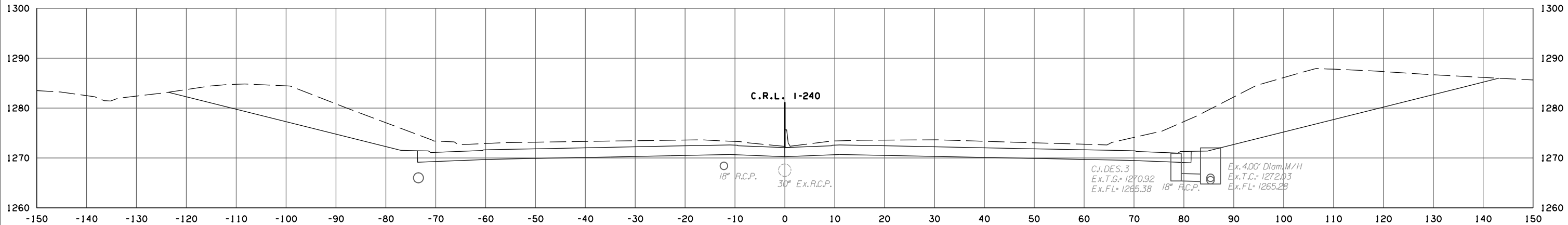

A 452+25.00

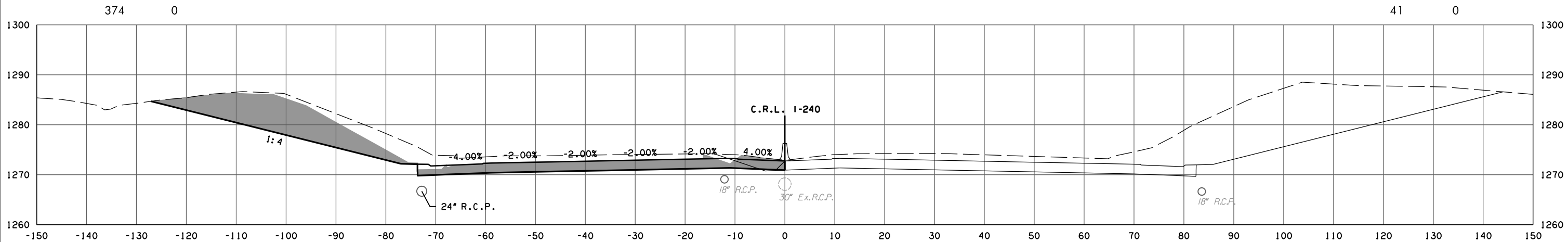

F.G. ELEV. = 1273.29
 A 452+00.00

CRL 1-240 W.B. PHASE 4
 STATE JOB NO. 09032(08)
 OKLAHOMA COUNTY SHEET NO. X101

3/4/2024 3:56:58 PM
 H:\PROJECTS\2789_CrossRoads_Phase 4\Roadway\Drawings\Sections\0903208-XSEC.CRL.WB.1-240.dgn

(CAUTION) THE LOCATION OF ALL UTILITIES AS SHOWN ARE APPROXIMATE. DUE TO RELOCATION'S PLANNED OR PRESENTLY UNDER CONSTRUCTION THERE ARE SOME UTILITIES THAT WILL BE RELOCATED AND NOT SHOWN ON THESE PLANS. THE CONTRACTOR SHALL BE RESPONSIBLE FOR ANY DAMAGE TO ALL UTILITIES.
 DEPTH & LOCATION OF EXISTING UTILITIES SHALL BE FIELD VERIFIED BY THE CONTRACTOR PRIOR TO CONSTRUCTION.

SEE DRAINAGE AREA MAP SHEETS FOR DRAINAGE SYMBOLOLOGY.

R/W & U/E PURCHASED UNDER JP 09032(05)

POB & ASSOCIATES, OKLAHOMA CITY, OK.

90% PLAN SUBMITTAL

3/4/2024

AREA
 CUT FILL

VOLUME
 CUT FILL

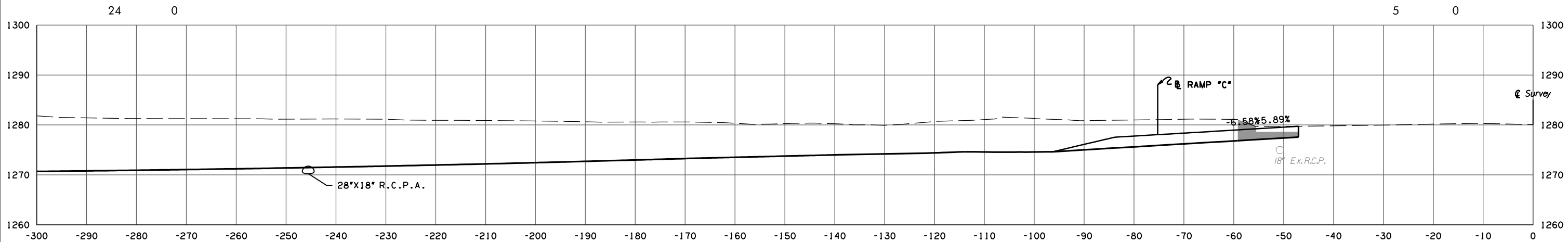

83 + 00.00

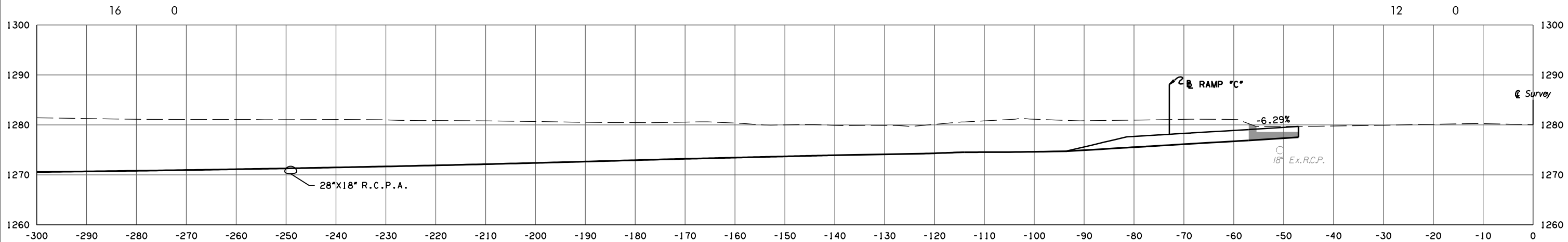

82 + 93.82

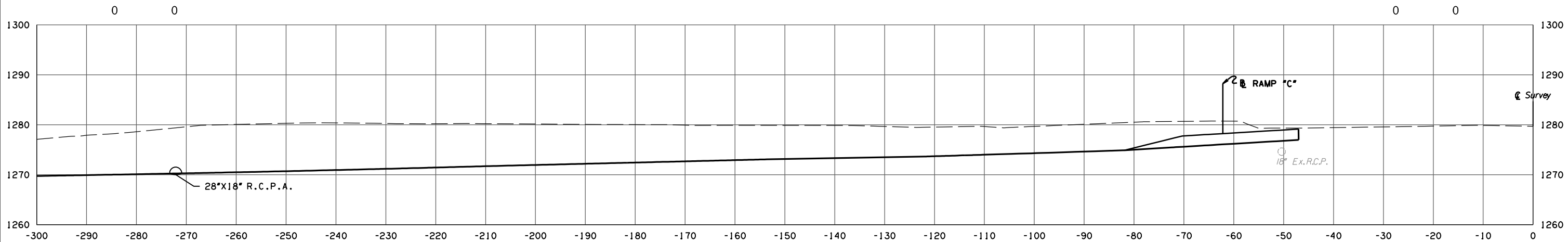

82 + 53.28
 BEGIN CONSTRUCTION

CL 1-35 WIDENING PHASE 4

STATE JOB NO. 09032(08)
 OKLAHOMA COUNTY SHEET NO. X102

3/4/2024 3:56:59 PM H:\PROJECTS\2789_CrossRoads_Phase 4\Roadway\Drawings\Sections\0903208-XSEC-I-35 SB SHLDR WIDENING.dgn

(CAUTION) THE LOCATION OF ALL UTILITIES AS SHOWN ARE APPROXIMATE. DUE TO RELOCATION'S PLANNED OR PRESENTLY UNDER CONSTRUCTION THERE ARE SOME UTILITIES THAT WILL BE RELOCATED AND NOT SHOWN ON THESE PLANS. THE CONTRACTOR SHALL BE RESPONSIBLE FOR ANY DAMAGE TO ALL UTILITIES.

DEPTH & LOCATION OF EXISTING UTILITIES SHALL BE FIELD VERIFIED BY THE CONTRACTOR PRIOR TO CONSTRUCTION.

SEE DRAINAGE AREA MAP SHEETS FOR DRAINAGE SYMBOLOLOGY.

R/W & U/E PURCHASED UNDER JP 09032(05)

POB & ASSOCIATES, OKLAHOMA CITY, OK.

**90% PLAN
SUBMITTAL**

3/4/2024

AREA
CUT FILL

VOLUME
CUT FILL

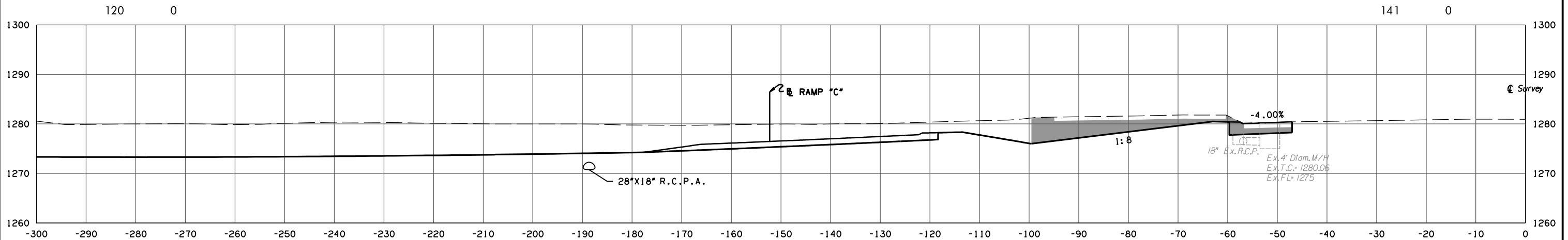

84 + 00.00

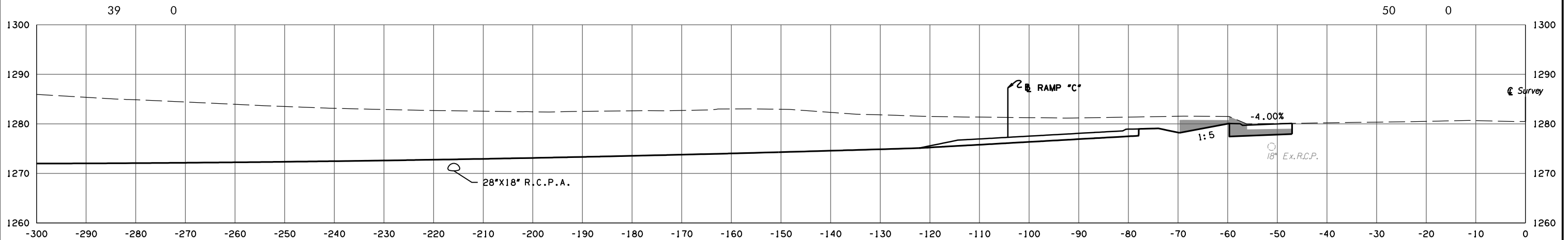

83 + 52.09

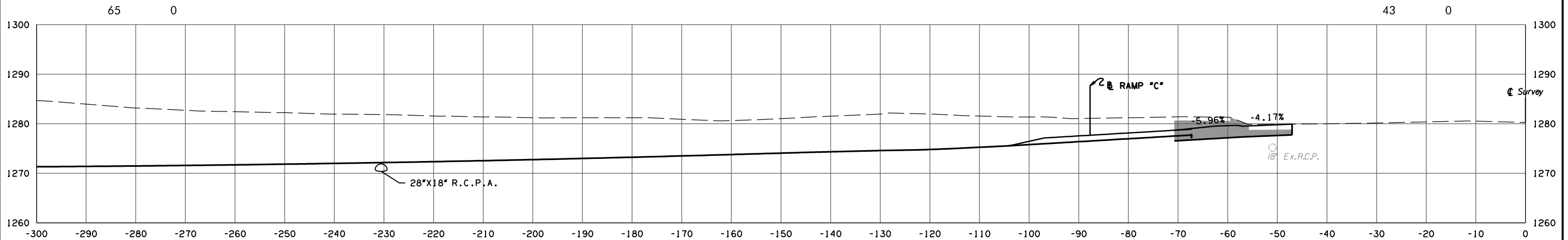

83 + 26.37

CL 1-35 WIDENING PHASE 4
STATE JOB NO. 09032(08)
OKLAHOMA COUNTY SHEET NO. X103

3/4/2024 3:57:00 PM
H:\PROJECTS\2785_CrossRoads_Phase 4\Roadway\Drawings\Sections\0903208-XSEC-I-35 SB SHLDR WIDENING.dgn

(CAUTION) THE LOCATION OF ALL UTILITIES AS SHOWN ARE APPROXIMATE. DUE TO RELOCATION'S PLANNED OR PRESENTLY UNDER CONSTRUCTION THERE ARE SOME UTILITIES THAT WILL BE RELOCATED AND NOT SHOWN ON THESE PLANS. THE CONTRACTOR SHALL BE RESPONSIBLE FOR ANY DAMAGE TO ALL UTILITIES.

DEPTH & LOCATION OF EXISTING UTILITIES SHALL BE FIELD VERIFIED BY THE CONTRACTOR PRIOR TO CONSTRUCTION.

SEE DRAINAGE AREA MAP SHEETS FOR DRAINAGE SYMBOLOLOGY.

R/W & U/E PURCHASED UNDER JP 09032(05)

POB & ASSOCIATES, OKLAHOMA CITY, OK

**90% PLAN
SUBMITTAL**

3/4/2024

AREA
CUT FILL

VOLUME
CUT FILL

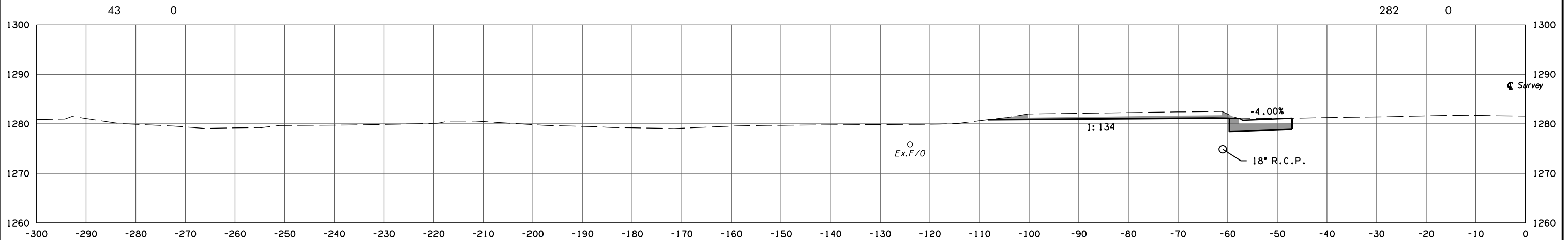

85+00.00

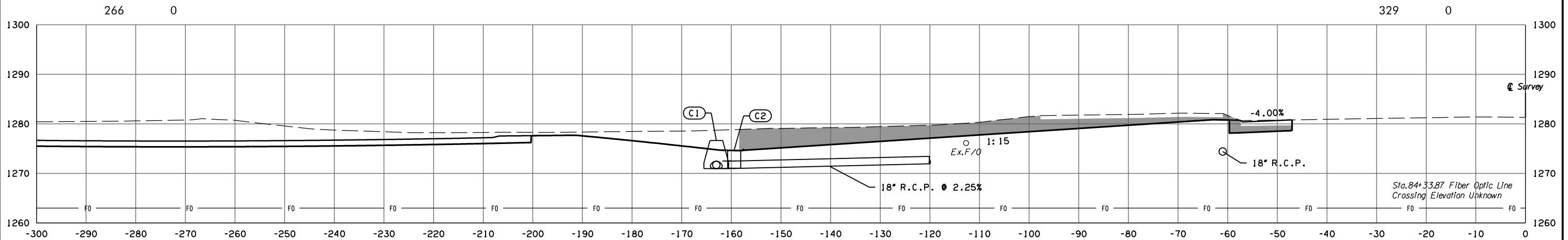

84+50.57

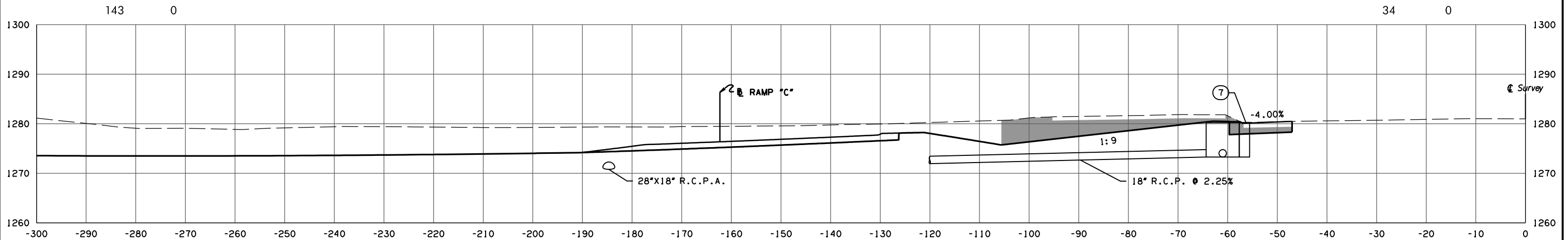

84+07.00

CL 1-35 WIDENING PHASE 4

STATE JOB NO. 09032(08)
OKLAHOMA COUNTY SHEET NO. X104

3/4/2024 3:57:01 PM H:\PROJECTS\2789_CrossRoads_Phase 4\Roadway\Drawings\Sections\0903208-XSEC1-35 SB SHLDR WIDENING.dgn

(CAUTION) THE LOCATION OF ALL UTILITIES AS SHOWN ARE APPROXIMATE. DUE TO RELOCATION'S PLANNED OR PRESENTLY UNDER CONSTRUCTION THERE ARE SOME UTILITIES THAT WILL BE RELOCATED AND NOT SHOWN ON THESE PLANS. THE CONTRACTOR SHALL BE RESPONSIBLE FOR ANY DAMAGE TO ALL UTILITIES.

DEPTH & LOCATION OF EXISTING UTILITIES SHALL BE FIELD VERIFIED BY THE CONTRACTOR PRIOR TO CONSTRUCTION.

SEE DRAINAGE AREA MAP SHEETS FOR DRAINAGE SYMBOLOLOGY.

R/W & U/E PURCHASED UNDER JP 09032(05)

POB & ASSOCIATES, OKLAHOMA CITY, OK.

**90% PLAN
SUBMITTAL**

3/4/2024

AREA
CUT FILL

VOLUME
CUT FILL

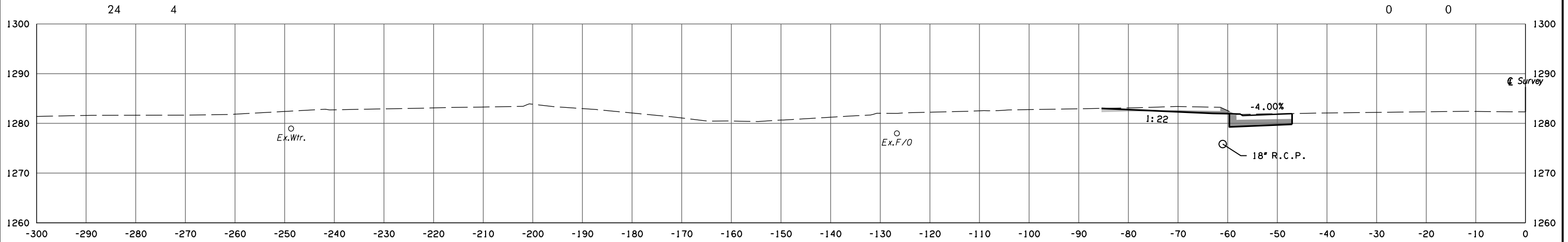

86+00.00

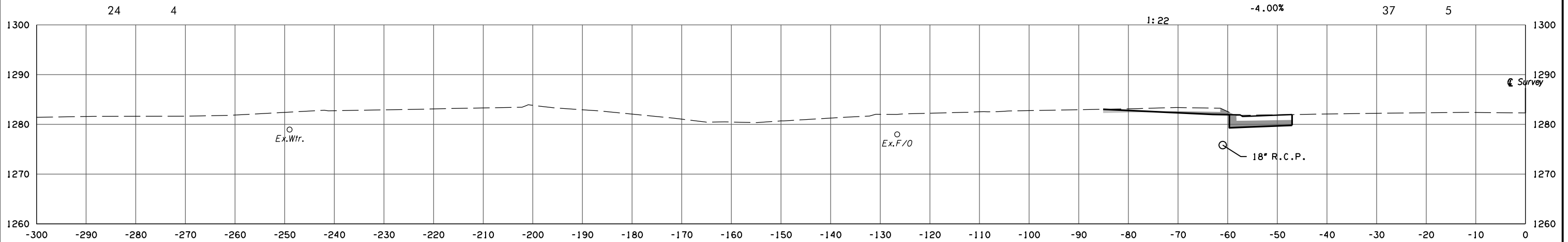

85+99.69

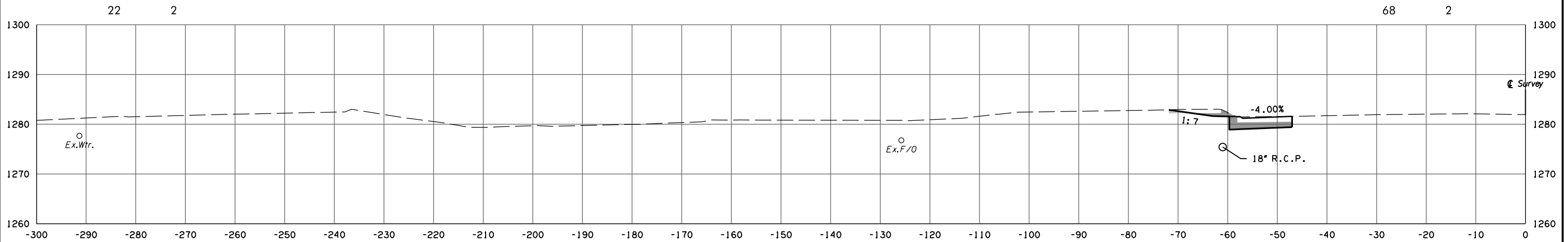

85+56.50

CL 1-35 WIDENING PHASE 4

STATE JOB NO.	09032(08)
OKLAHOMA COUNTY	SHEET NO. X105

3/4/2024 3:57:01 PM H:\PROJECTS\2785_CrossRoads_Phase 4\Roadway\Drawings\Sections\0903208-XSEC-I-35 SB SHLDR WIDENING.dgn

(CAUTION) THE LOCATION OF ALL UTILITIES AS SHOWN ARE APPROXIMATE. DUE TO RELOCATION'S PLANNED OR PRESENTLY UNDER CONSTRUCTION THERE ARE SOME UTILITIES THAT WILL BE RELOCATED AND NOT SHOWN ON THESE PLANS. THE CONTRACTOR SHALL BE RESPONSIBLE FOR ANY DAMAGE TO ALL UTILITIES.
 DEPTH & LOCATION OF EXISTING UTILITIES SHALL BE FIELD VERIFIED BY THE CONTRACTOR PRIOR TO CONSTRUCTION.

SEE DRAINAGE AREA MAP SHEETS FOR DRAINAGE SYMBOLOLOGY.

R/W & U/E PURCHASED UNDER JP 09032(05)

POB & ASSOCIATES, OKLAHOMA CITY, OK.
90% PLAN SUBMITTAL
 3/4/2024

AREA
 CUT FILL

VOLUME
 CUT FILL

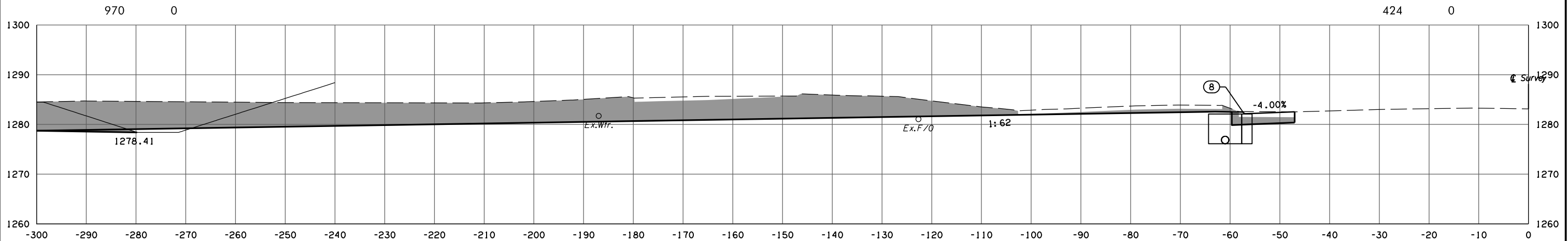

87+12.00

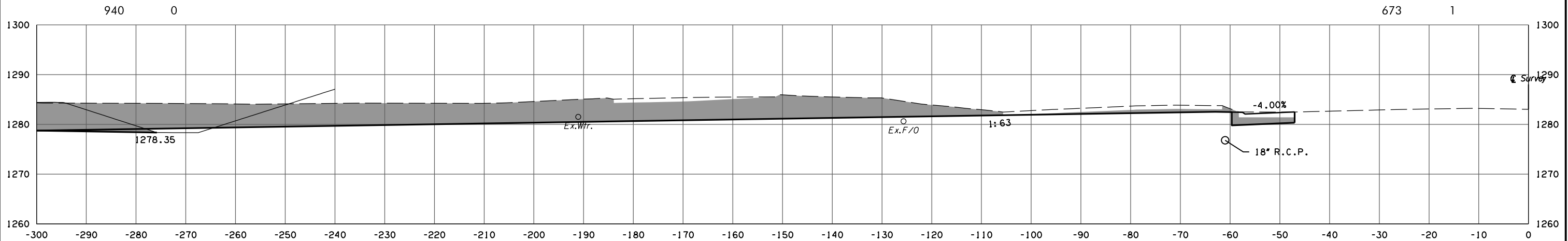

87+00.00

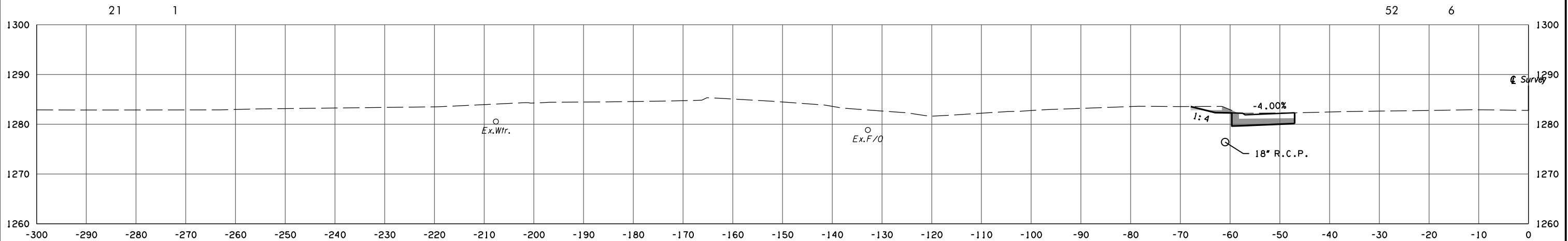

86+62.19

CL 1-35 WIDENING PHASE 4
 STATE JOB NO. 09032(08)
 OKLAHOMA COUNTY SHEET NO. X106

3/4/2024 3:57:02 PM
 H:\PROJECTS\2785_CrossRoads_Phase 4\Roadway\Drawings\Sections\0903208-XSEC-I-35 SB SHLDR WIDENING.dgn

(CAUTION) THE LOCATION OF ALL UTILITIES AS SHOWN ARE APPROXIMATE. DUE TO RELOCATION'S PLANNED OR PRESENTLY UNDER CONSTRUCTION THERE ARE SOME UTILITIES THAT WILL BE RELOCATED AND NOT SHOWN ON THESE PLANS. THE CONTRACTOR SHALL BE RESPONSIBLE FOR ANY DAMAGE TO ALL UTILITIES.

DEPTH & LOCATION OF EXISTING UTILITIES SHALL BE FIELD VERIFIED BY THE CONTRACTOR PRIOR TO CONSTRUCTION.

SEE DRAINAGE AREA MAP SHEETS FOR DRAINAGE SYMBOLOLOGY.

R/W & U/E PURCHASED UNDER JP 09032(05)

POB & ASSOCIATES, OKLAHOMA CITY, OK.

**90% PLAN
SUBMITTAL**

3/4/2024

AREA
CUT FILL

VOLUME
CUT FILL

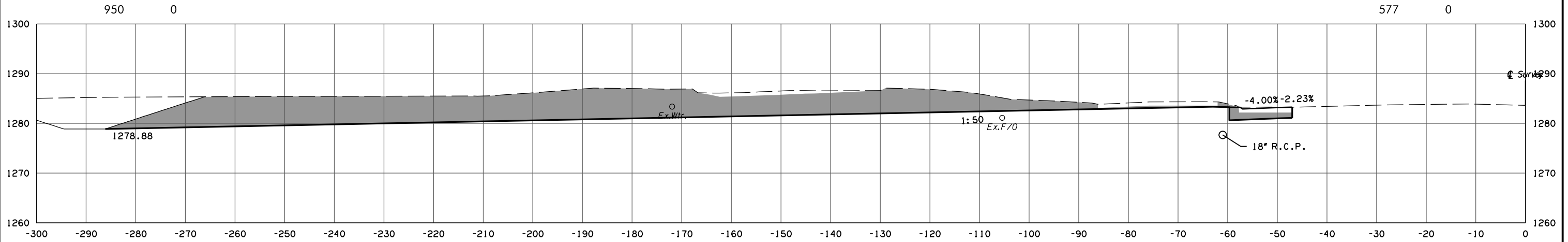

88 + 00.00

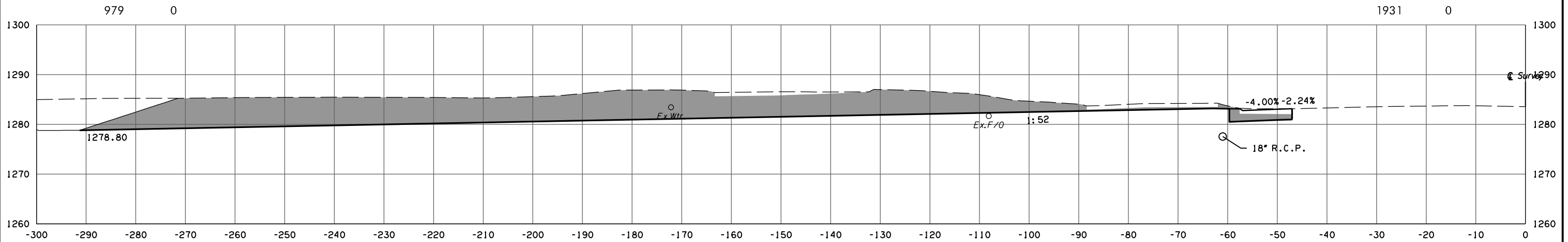

87 + 83.85

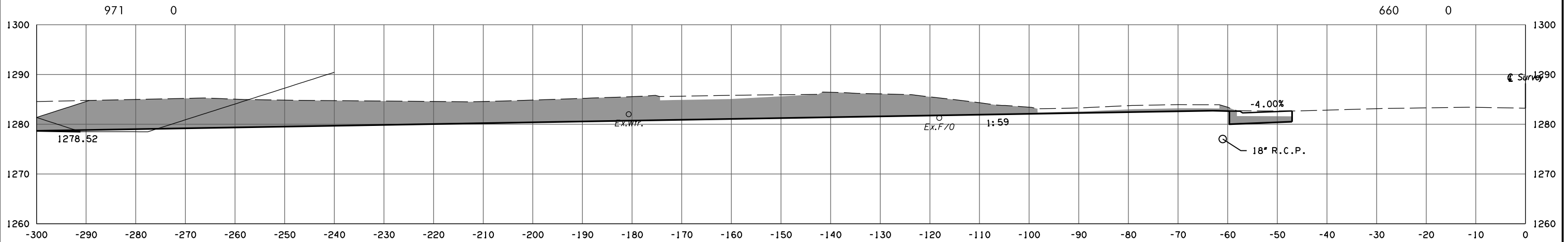

87 + 30.36

CL 1-35 WIDENING PHASE 4
STATE JOB NO. 09032(08)
OKLAHOMA COUNTY SHEET NO. X107

3/4/2024 3:57:03 PM H:\PROJECTS\2789_CrossRoads_Phase 4\Roadway\Drawings\Sections\0903208-XSEC-I-35 SB SHLDR WIDENING.dgn

(CAUTION) THE LOCATION OF ALL UTILITIES AS SHOWN ARE APPROXIMATE. DUE TO RELOCATION'S PLANNED OR PRESENTLY UNDER CONSTRUCTION THERE ARE SOME UTILITIES THAT WILL BE RELOCATED AND NOT SHOWN ON THESE PLANS. THE CONTRACTOR SHALL BE RESPONSIBLE FOR ANY DAMAGE TO ALL UTILITIES.
 DEPTH & LOCATION OF EXISTING UTILITIES SHALL BE FIELD VERIFIED BY THE CONTRACTOR PRIOR TO CONSTRUCTION.

SEE DRAINAGE AREA MAP SHEETS FOR DRAINAGE SYMBOLOLOGY.

R/W & U/E PURCHASED UNDER JP 09032(05)

POB & ASSOCIATES, OKLAHOMA CITY, OK.
90% PLAN SUBMITTAL
 3/4/2024

AREA
 CUT FILL

VOLUME
 CUT FILL

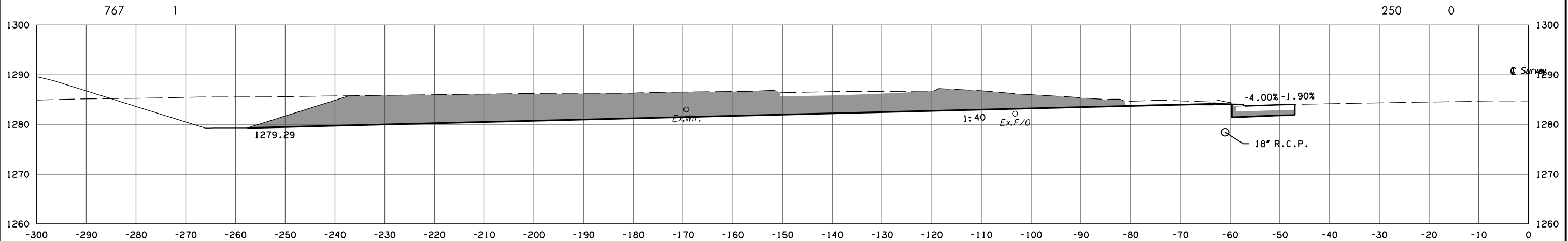

88+78.30

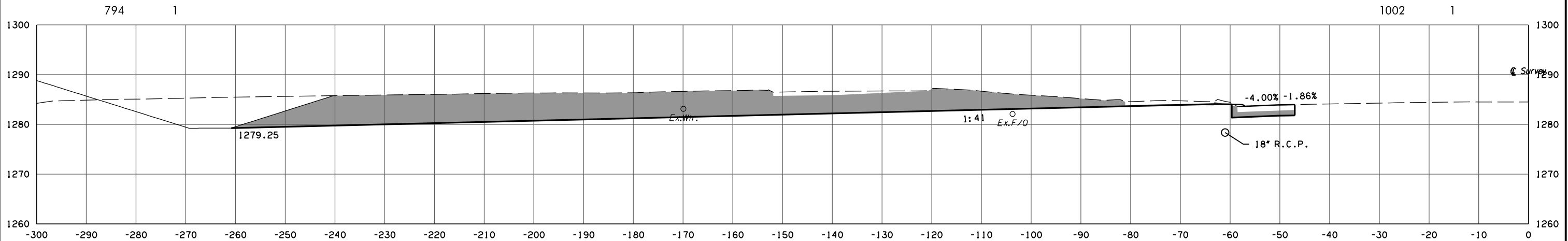

88+69.66

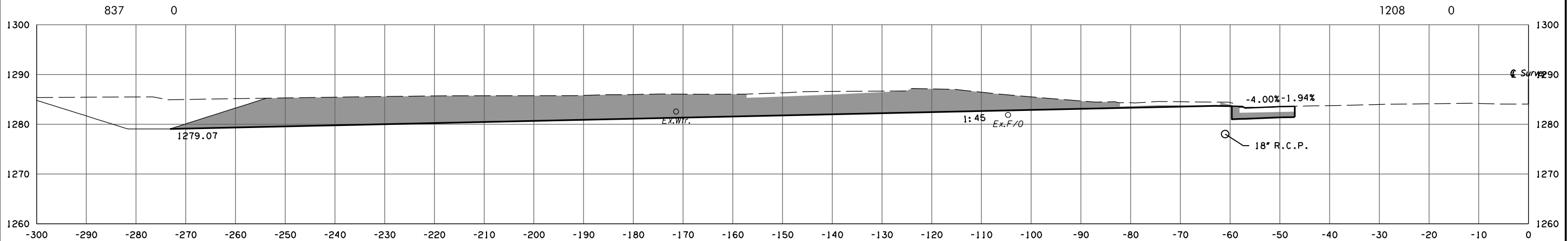

88+36.48

CL 1-35 WIDENING PHASE 4
 STATE JOB NO. 09032(08)
 OKLAHOMA COUNTY SHEET NO. X108

3/4/2024 3:57:03 PM
 H:\PROJECTS\2789_CrossRoads_Phase 4\Roadway\Drawings\Sections\0903208-XSEC-I-35 SB SHLDR WIDENING.dgn

(CAUTION) THE LOCATION OF ALL UTILITIES AS SHOWN ARE APPROXIMATE. DUE TO RELOCATION'S PLANNED OR PRESENTLY UNDER CONSTRUCTION THERE ARE SOME UTILITIES THAT WILL BE RELOCATED AND NOT SHOWN ON THESE PLANS. THE CONTRACTOR SHALL BE RESPONSIBLE FOR ANY DAMAGE TO ALL UTILITIES.
 DEPTH & LOCATION OF EXISTING UTILITIES SHALL BE FIELD VERIFIED BY THE CONTRACTOR PRIOR TO CONSTRUCTION.

SEE DRAINAGE AREA MAP SHEETS FOR DRAINAGE SYMBOLOLOGY.

R/W & U/E PURCHASED UNDER JP 09032(05)

POB & ASSOCIATES, OKLAHOMA CITY, OK.
90% PLAN SUBMITTAL
 3/4/2024

AREA
 CUT FILL

VOLUME
 CUT FILL

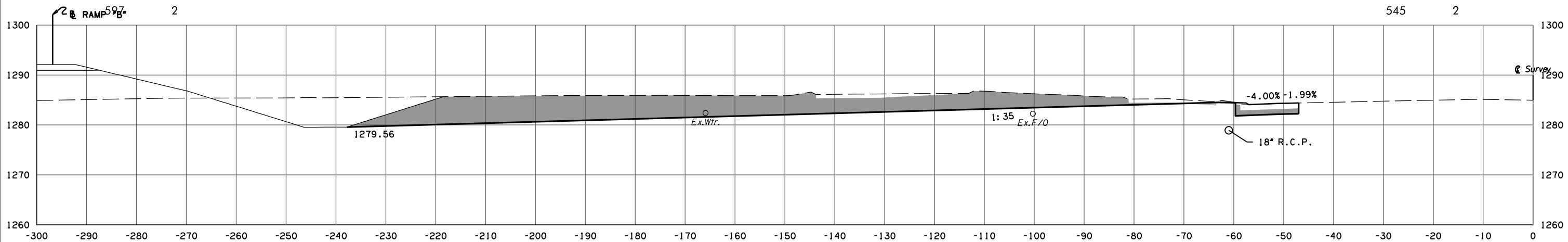

89+29.37

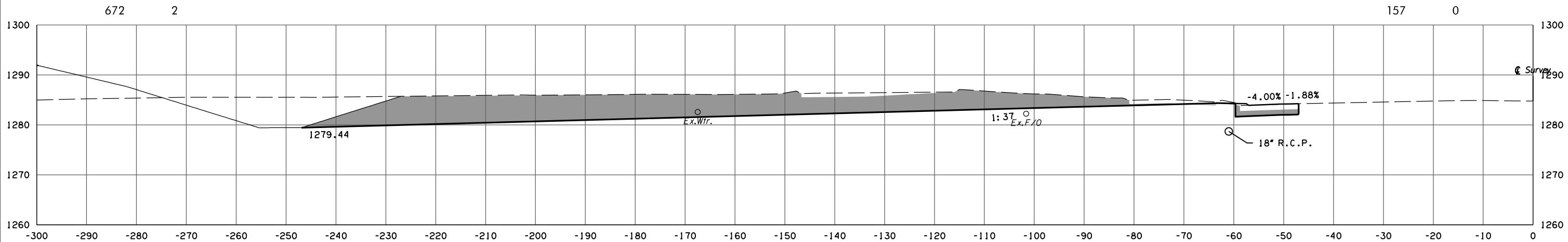

89+06.21

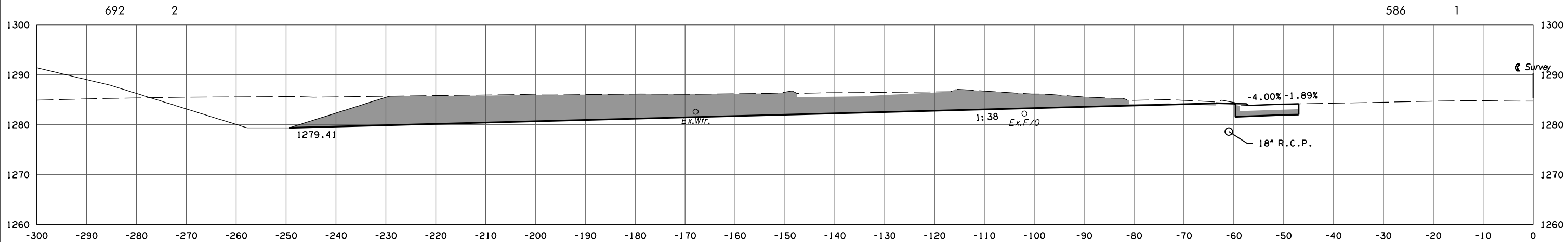

89+00.00

CL 1-35 WIDENING PHASE 4

STATE JOB NO. 09032(08)
 OKLAHOMA COUNTY SHEET NO. X109

3/4/2024 3:57:04 PM
 H:\PROJECTS\2789_CrossRoads_Phase 4\Roadway\Drawings\Sections\0903208-XSEC-I-35 SB SHLDR WIDENING.dgn

(CAUTION) THE LOCATION OF ALL UTILITIES AS SHOWN ARE APPROXIMATE. DUE TO RELOCATION'S PLANNED OR PRESENTLY UNDER CONSTRUCTION THERE ARE SOME UTILITIES THAT WILL BE RELOCATED AND NOT SHOWN ON THESE PLANS. THE CONTRACTOR SHALL BE RESPONSIBLE FOR ANY DAMAGE TO ALL UTILITIES.

DEPTH & LOCATION OF EXISTING UTILITIES SHALL BE FIELD VERIFIED BY THE CONTRACTOR PRIOR TO CONSTRUCTION.

SEE DRAINAGE AREA MAP SHEETS FOR DRAINAGE SYMBOLOLOGY.

R/W & U/E PURCHASED UNDER JP 09032(05)

POB & ASSOCIATES, OKLAHOMA CITY, OK.

**90% PLAN
SUBMITTAL**

3/4/2024

AREA
CUT FILL

VOLUME
CUT FILL

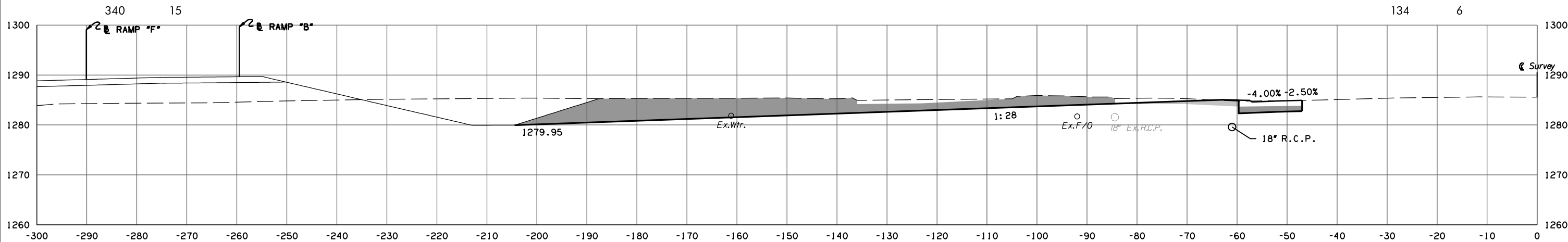

90+00.00

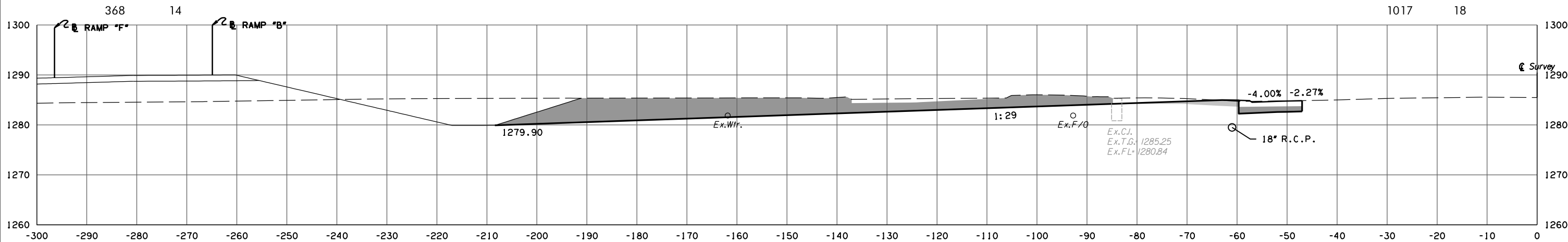

89+89.81

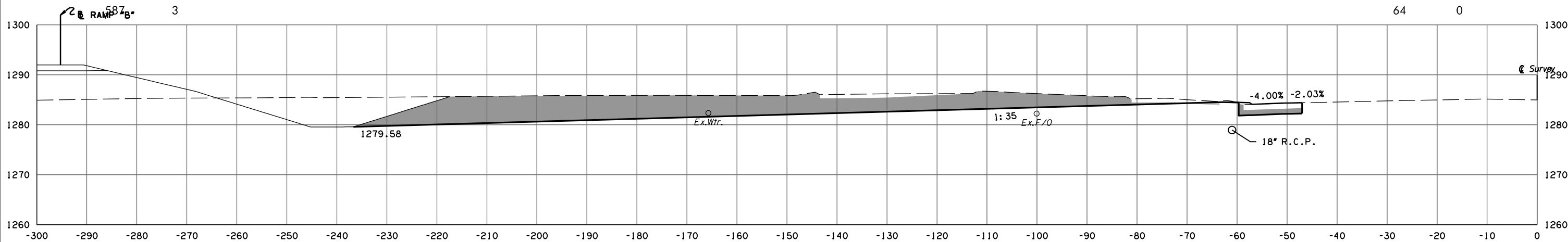

89+32.30

CL 1-35 WIDENING PHASE 4

STATE JOB NO. 09032(08)
OKLAHOMA COUNTY SHEET NO. X110

3/4/2024 3:57:05 PM H:\PROJECTS\21789_CrossRoads_Phase 4\Roadway\Drawings\Sections\0903208-XSEC-I-35 SB SHLDR WIDENING.dgn

(CAUTION) THE LOCATION OF ALL UTILITIES AS SHOWN ARE APPROXIMATE. DUE TO RELOCATION'S PLANNED OR PRESENTLY UNDER CONSTRUCTION THERE ARE SOME UTILITIES THAT WILL BE RELOCATED AND NOT SHOWN ON THESE PLANS. THE CONTRACTOR SHALL BE RESPONSIBLE FOR ANY DAMAGE TO ALL UTILITIES.

DEPTH & LOCATION OF EXISTING UTILITIES SHALL BE FIELD VERIFIED BY THE CONTRACTOR PRIOR TO CONSTRUCTION.

SEE DRAINAGE AREA MAP SHEETS FOR DRAINAGE SYMBOLOLOGY.

R/W & U/E PURCHASED UNDER JP 09032(05)

POB & ASSOCIATES, OKLAHOMA CITY, OK.

**90% PLAN
SUBMITTAL**

3/4/2024

AREA

CUT	FILL
93	35

VOLUME

CUT	FILL
176	38

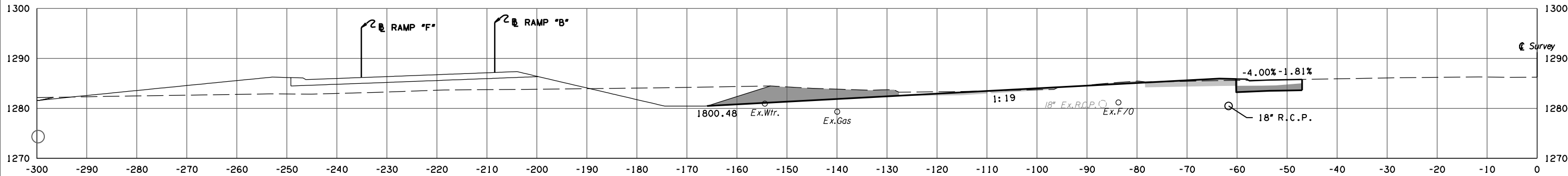

91+00.00

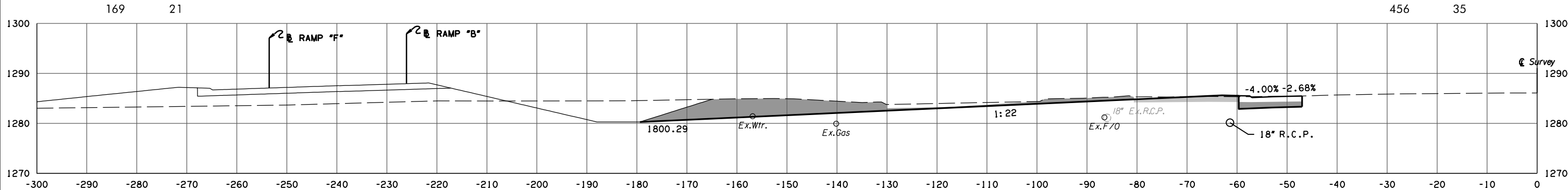

90+63.80

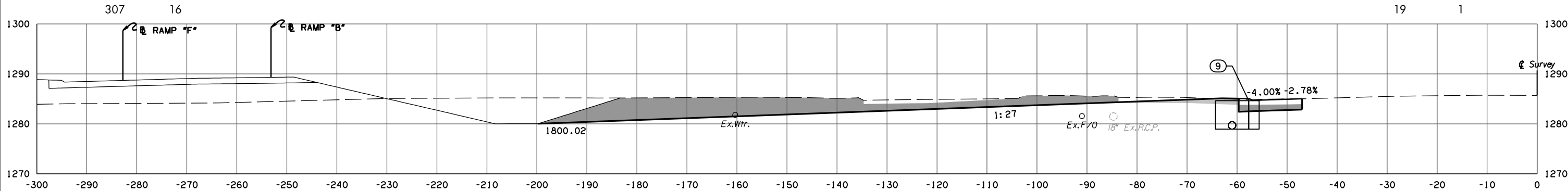

90+12.00

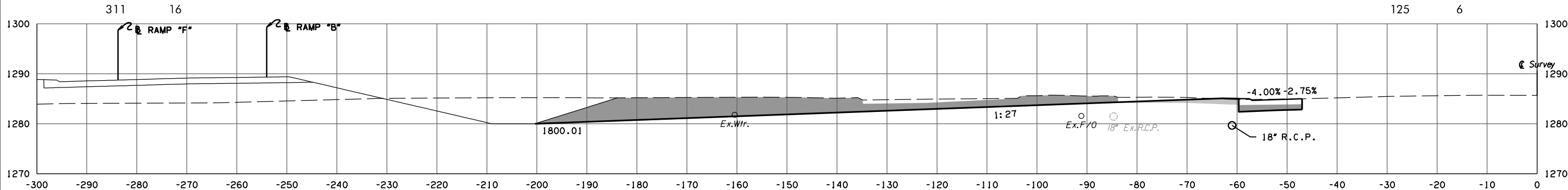

90+10.37

CL 1-35 WIDENING PHASE 4

STATE JOB NO. 09032(08)
OKLAHOMA COUNTY SHEET NO. X111

3/4/2024 3:57:05 PM H:\PROJECTS\2789_CrossRoads_Phase 4\Roadway\Drawings\Sections\0903208-XSEC-I-35 SB SHLDR WIDENING.dgn

(CAUTION) THE LOCATION OF ALL UTILITIES AS SHOWN ARE APPROXIMATE. DUE TO RELOCATION'S PLANNED OR PRESENTLY UNDER CONSTRUCTION THERE ARE SOME UTILITIES THAT WILL BE RELOCATED AND NOT SHOWN ON THESE PLANS. THE CONTRACTOR SHALL BE RESPONSIBLE FOR ANY DAMAGE TO ALL UTILITIES.

SEE DRAINAGE AREA MAP SHEETS FOR DRAINAGE SYMBOLOLOGY.

R/W & U/E PURCHASED UNDER JP 09032(05)

POE & ASSOCIATES, OKLAHOMA CITY, OK.

**90% PLAN
SUBMITTAL**

3/4/2024

DEPTH & LOCATION OF EXISTING UTILITIES SHALL BE FIELD VERIFIED BY THE CONTRACTOR PRIOR TO CONSTRUCTION.

AREA
CUT FILL

VOLUME
CUT FILL



91+99.52

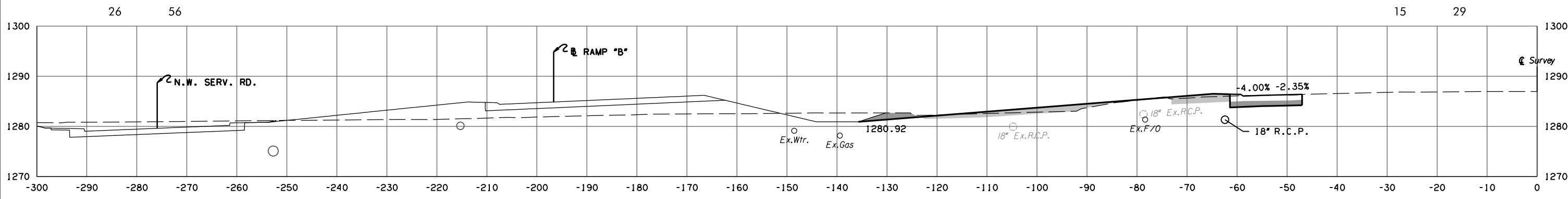

91+87.16

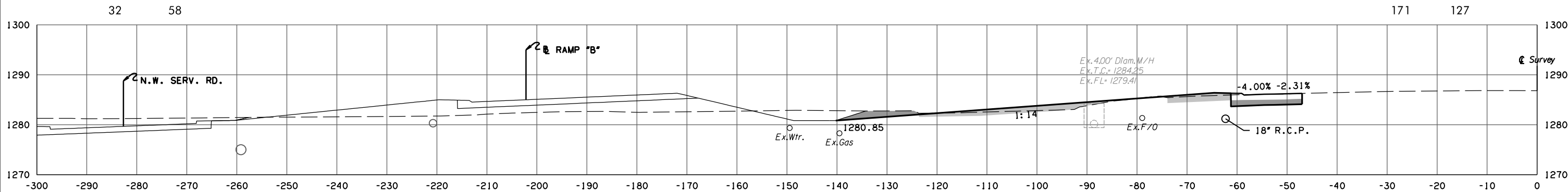

91+73.59

3/4/2024 3:57:06 PM H:\PROJECTS\2789_CrossRoads_Phase 4\Roadway\Drawings\Sections\0903208-XSEC-I-35 SB SHLDR WIDENING.dgn

CL 1-35 WIDENING PHASE 4
STATE JOB NO. 09032(08)
OKLAHOMA COUNTY SHEET NO. X112

(CAUTION) THE LOCATION OF ALL UTILITIES AS SHOWN ARE APPROXIMATE. DUE TO RELOCATION'S PLANNED OR PRESENTLY UNDER CONSTRUCTION THERE ARE SOME UTILITIES THAT WILL BE RELOCATED AND NOT SHOWN ON THESE PLANS. THE CONTRACTOR SHALL BE RESPONSIBLE FOR ANY DAMAGE TO ALL UTILITIES.
 DEPTH & LOCATION OF EXISTING UTILITIES SHALL BE FIELD VERIFIED BY THE CONTRACTOR PRIOR TO CONSTRUCTION.

SEE DRAINAGE AREA MAP SHEETS FOR DRAINAGE SYMBOLOLOGY.

R/W & U/E PURCHASED UNDER JP 09032(05)

POB & ASSOCIATES, OKLAHOMA CITY, OK.

90% PLAN SUBMITTAL

3/4/2024

AREA
 CUT FILL

VOLUME
 CUT FILL

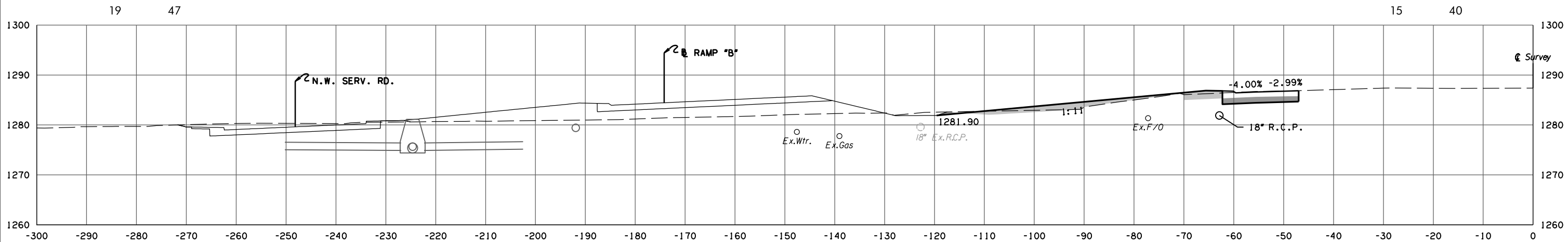

92 + 47.05

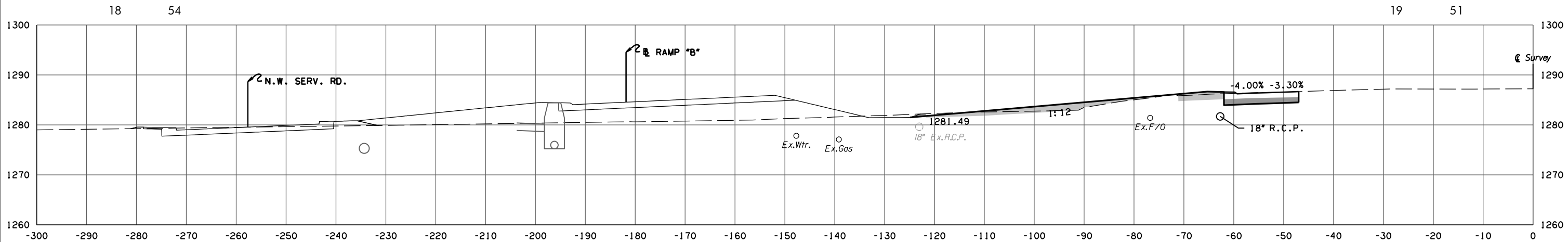

92 + 25.73

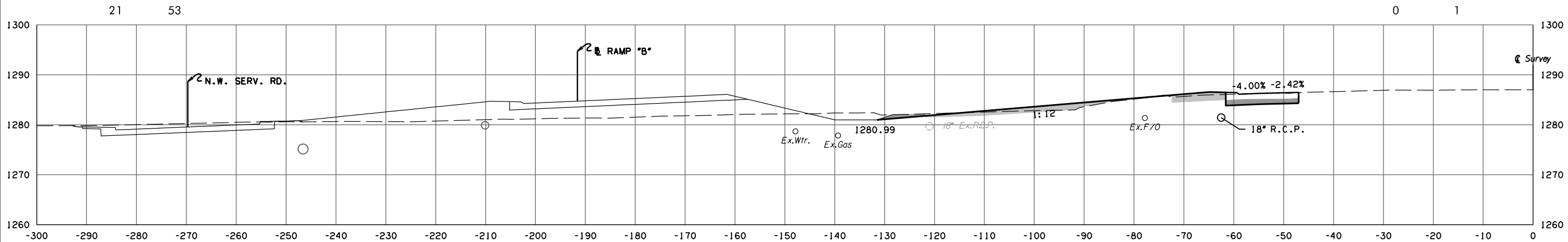

92 + 00.00

CL 1-35 WIDENING PHASE 4

STATE JOB NO. 09032(08)
 OKLAHOMA COUNTY SHEET NO. X113

3/4/2024 3:57:06 PM
 H:\PROJECTS\2789_CrossRoads_Phase 4\Roadway\Drawings\Sections\0903208-XSEC-I-35 SB SHLDR WIDENING.dgn

(CAUTION) THE LOCATION OF ALL UTILITIES AS SHOWN ARE APPROXIMATE. DUE TO RELOCATION'S PLANNED OR PRESENTLY UNDER CONSTRUCTION THERE ARE SOME UTILITIES THAT WILL BE RELOCATED AND NOT SHOWN ON THESE PLANS. THE CONTRACTOR SHALL BE RESPONSIBLE FOR ANY DAMAGE TO ALL UTILITIES.
 DEPTH & LOCATION OF EXISTING UTILITIES SHALL BE FIELD VERIFIED BY THE CONTRACTOR PRIOR TO CONSTRUCTION.

SEE DRAINAGE AREA MAP SHEETS FOR DRAINAGE SYMBOLOLOGY.

R/W & U/E PURCHASED UNDER JP 09032(05)

POB & ASSOCIATES, OKLAHOMA CITY, OK.
90% PLAN SUBMITTAL
 3/4/2024

AREA
 CUT FILL

VOLUME
 CUT FILL

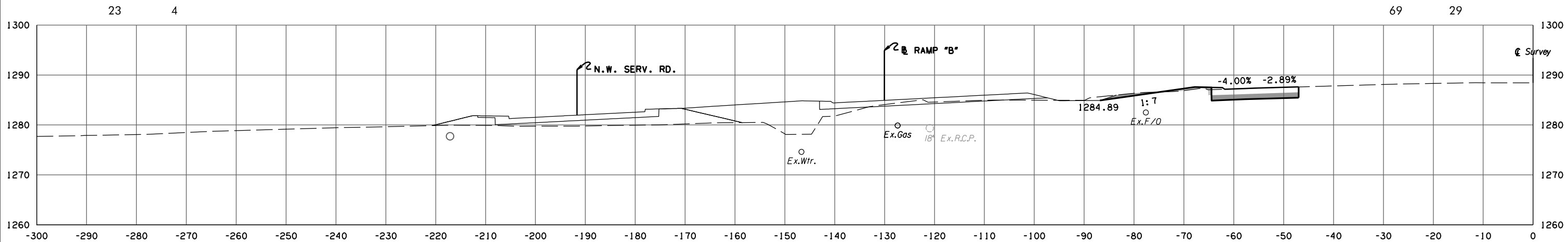

94+00.00

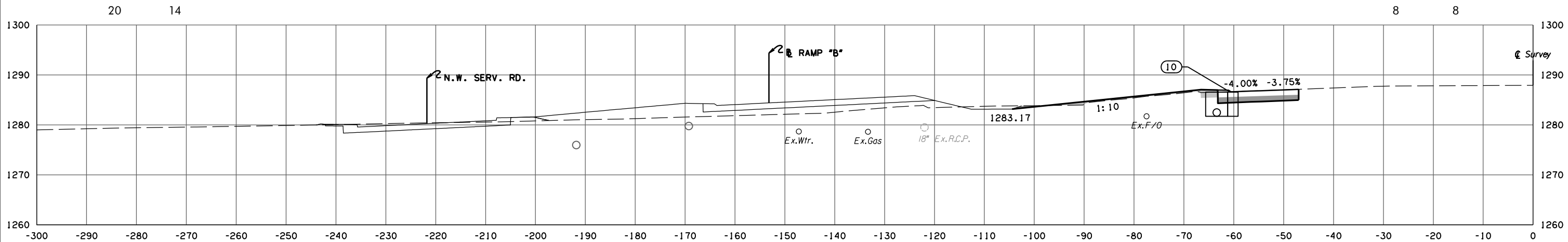

93+12.00

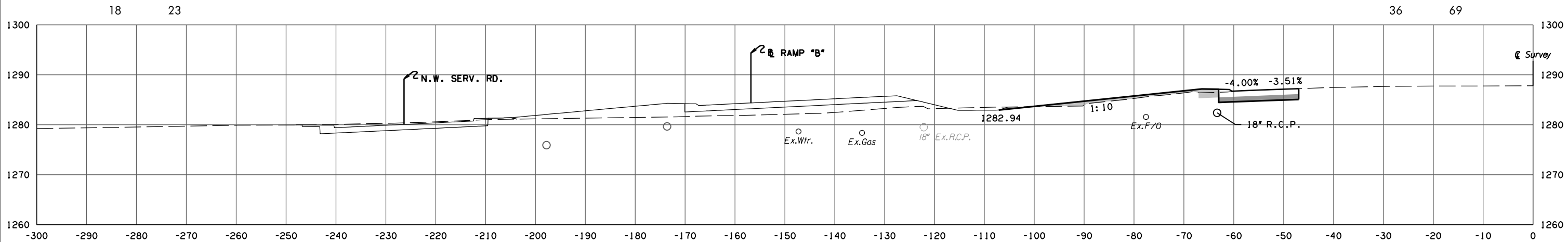

93+00.00

CL 1-35 WIDENING PHASE 4
 STATE JOB NO. 09032(08)
 OKLAHOMA COUNTY SHEET NO. X114

3/4/2024 3:57:07 PM
 H:\PROJECTS\2789_CrossRoads_Phase 4\Roadway\Drawings\Sections\0903208-XSEC-I-35 SB SHLDR WIDENING.dgn

(CAUTION) THE LOCATION OF ALL UTILITIES AS SHOWN ARE APPROXIMATE. DUE TO RELOCATION'S PLANNED OR PRESENTLY UNDER CONSTRUCTION THERE ARE SOME UTILITIES THAT WILL BE RELOCATED AND NOT SHOWN ON THESE PLANS. THE CONTRACTOR SHALL BE RESPONSIBLE FOR ANY DAMAGE TO ALL UTILITIES.
 DEPTH & LOCATION OF EXISTING UTILITIES SHALL BE FIELD VERIFIED BY THE CONTRACTOR PRIOR TO CONSTRUCTION.

SEE DRAINAGE AREA MAP SHEETS FOR DRAINAGE SYMBOLOLOGY.

R/W & U/E PURCHASED UNDER JP 09032(05)

POE & ASSOCIATES, OKLAHOMA CITY, OK.
90% PLAN SUBMITTAL
 3/4/2024

AREA
 CUT FILL

VOLUME
 CUT FILL

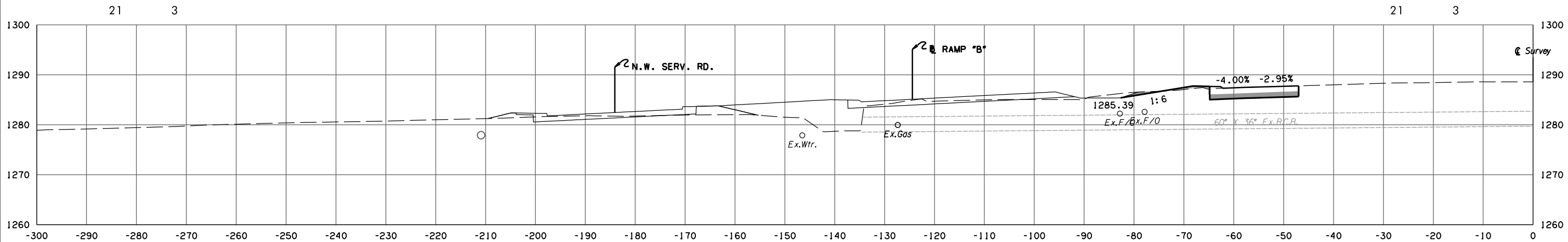
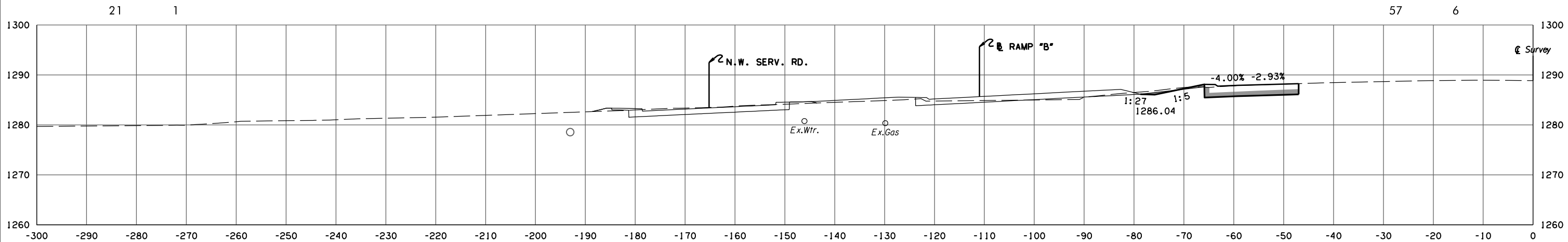
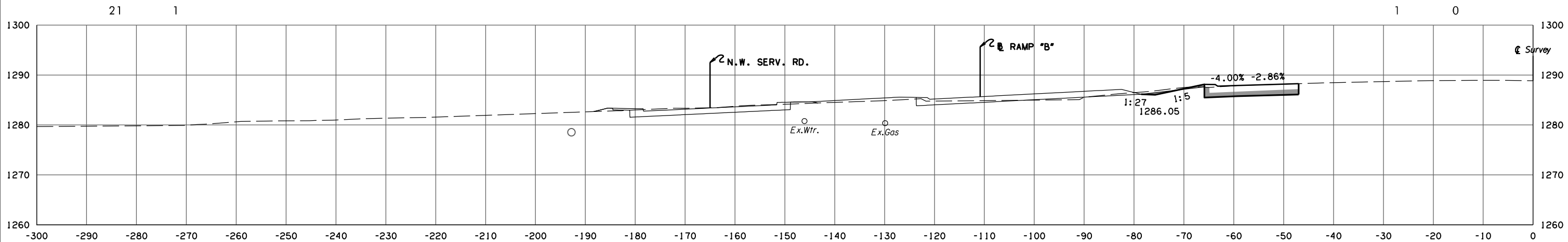

3/4/2024 3:57:08 PM H:\PROJECTS\2789_CrossRoads_Phase 4\Roadway\Drawings\Sections\0903208-XSEC-I-35 SB SHLDR WIDENING.dgn

CL 1-35 WIDENING PHASE 4
 STATE JOB NO. 09032(08)
 OKLAHOMA COUNTY SHEET NO. X115

(CAUTION) THE LOCATION OF ALL UTILITIES AS SHOWN ARE APPROXIMATE. DUE TO RELOCATION'S PLANNED OR PRESENTLY UNDER CONSTRUCTION THERE ARE SOME UTILITIES THAT WILL BE RELOCATED AND NOT SHOWN ON THESE PLANS. THE CONTRACTOR SHALL BE RESPONSIBLE FOR ANY DAMAGE TO ALL UTILITIES.
 DEPTH & LOCATION OF EXISTING UTILITIES SHALL BE FIELD VERIFIED BY THE CONTRACTOR PRIOR TO CONSTRUCTION.

SEE DRAINAGE AREA MAP SHEETS FOR DRAINAGE SYMBOLOLOGY.

R/W & U/E PURCHASED UNDER JP 09032(05)

POB & ASSOCIATES, OKLAHOMA CITY, OK.
90% PLAN SUBMITTAL
 3/4/2024

AREA
 CUT FILL

VOLUME
 CUT FILL

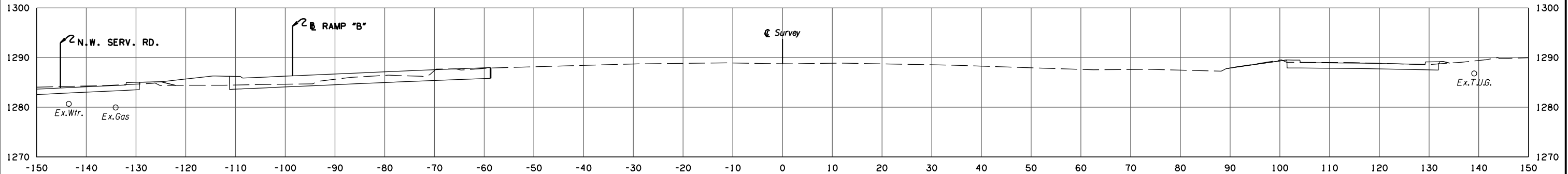

96+04.21

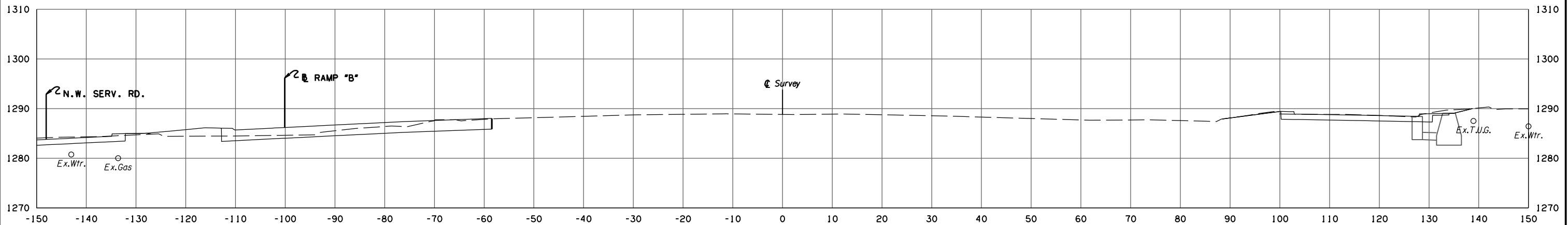

95+86.09

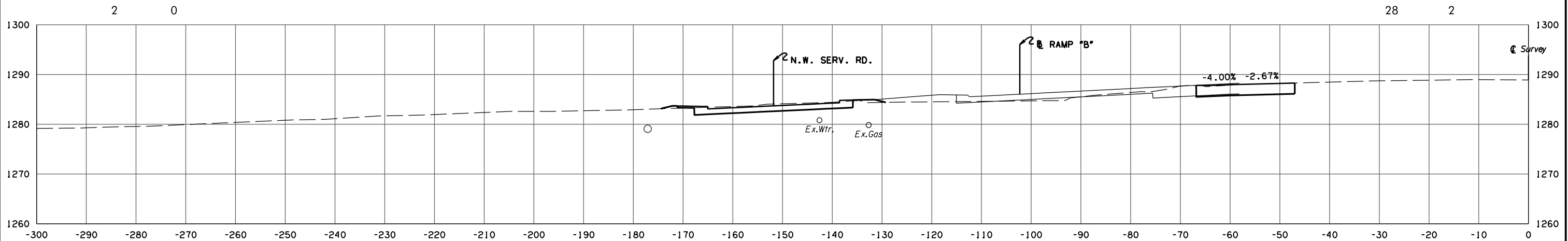

95+64.51
 END CONSTRUCTION

CL 1-35 WIDENING PHASE 4
 STATE JOB NO. 09032(08)
 OKLAHOMA COUNTY SHEET NO. X116

3/4/2024 3:57:08 PM
 H:\PROJECTS\2789_CrossRoads_Phase 4\Roadway\Drawings\Sections\0903208-XSEC-I-35 SB SHLDR WIDENING.dgn

(CAUTION) THE LOCATION OF ALL UTILITIES AS SHOWN ARE APPROXIMATE. DUE TO RELOCATION'S PLANNED OR PRESENTLY UNDER CONSTRUCTION THERE ARE SOME UTILITIES THAT WILL BE RELOCATED AND NOT SHOWN ON THESE PLANS. THE CONTRACTOR SHALL BE RESPONSIBLE FOR ANY DAMAGE TO ALL UTILITIES.
 DEPTH & LOCATION OF EXISTING UTILITIES SHALL BE FIELD VERIFIED BY THE CONTRACTOR PRIOR TO CONSTRUCTION.

SEE DRAINAGE AREA MAP SHEETS FOR DRAINAGE SYMBOLOLOGY.

R/W & U/E PURCHASED UNDER JP 09032(05)

POB & ASSOCIATES, OKLAHOMA CITY, OK.
90% PLAN SUBMITTAL
 3/4/2024

AREA
 CUT FILL

VOLUME
 CUT FILL

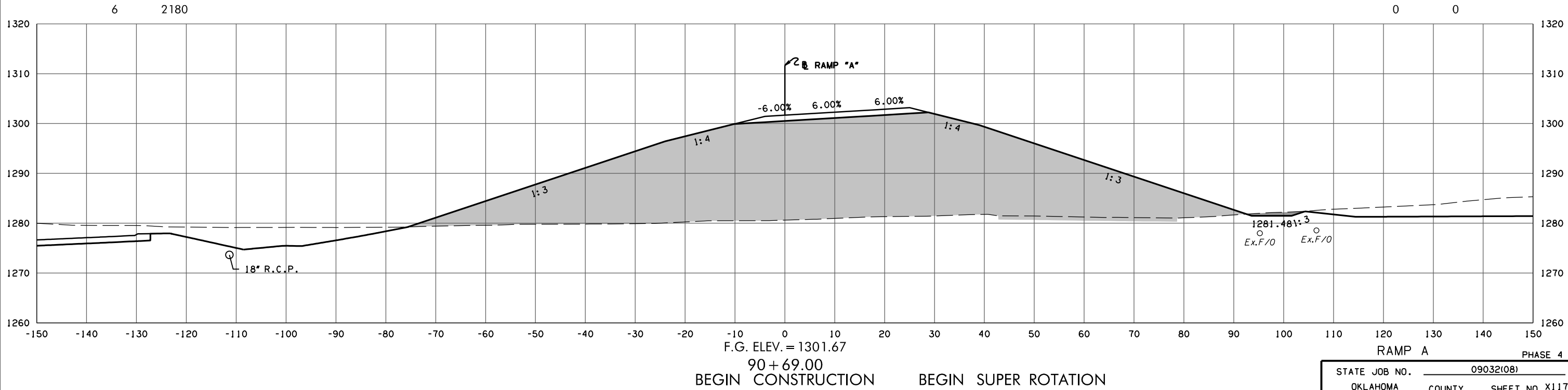
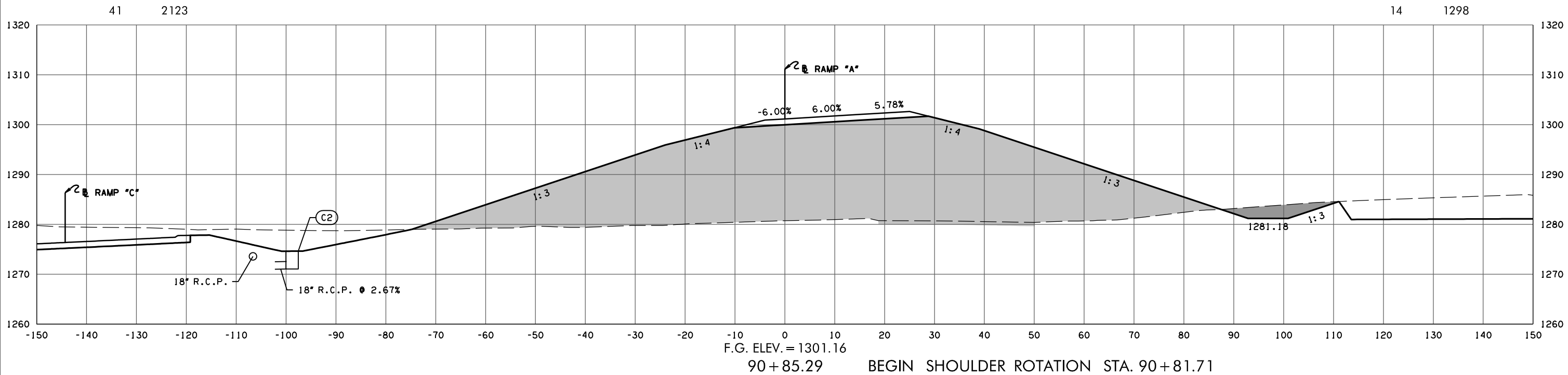

3/4/2024 3:57:09 PM H:\PROJECTS\2789_CrossRoads_Phase 4\Roadway\Drawings\Sections\0903208-XSEC_Ramp_A.dgn

STATE JOB NO. 09032(08)
 OKLAHOMA COUNTY SHEET NO. X117

(CAUTION) THE LOCATION OF ALL UTILITIES AS SHOWN ARE APPROXIMATE. DUE TO RELOCATION'S PLANNED OR PRESENTLY UNDER CONSTRUCTION THERE ARE SOME UTILITIES THAT WILL BE RELOCATED AND NOT SHOWN ON THESE PLANS. THE CONTRACTOR SHALL BE RESPONSIBLE FOR ANY DAMAGE TO ALL UTILITIES.

DEPTH & LOCATION OF EXISTING UTILITIES SHALL BE FIELD VERIFIED BY THE CONTRACTOR PRIOR TO CONSTRUCTION.

SEE DRAINAGE AREA MAP SHEETS FOR DRAINAGE SYMBOLOLOGY.

R/W & U/E PURCHASED UNDER JP 09032(05)

POB & ASSOCIATES, OKLAHOMA CITY, OK.

**90% PLAN
SUBMITTAL**

3/4/2024

AREA
CUT FILL

VOLUME
CUT FILL

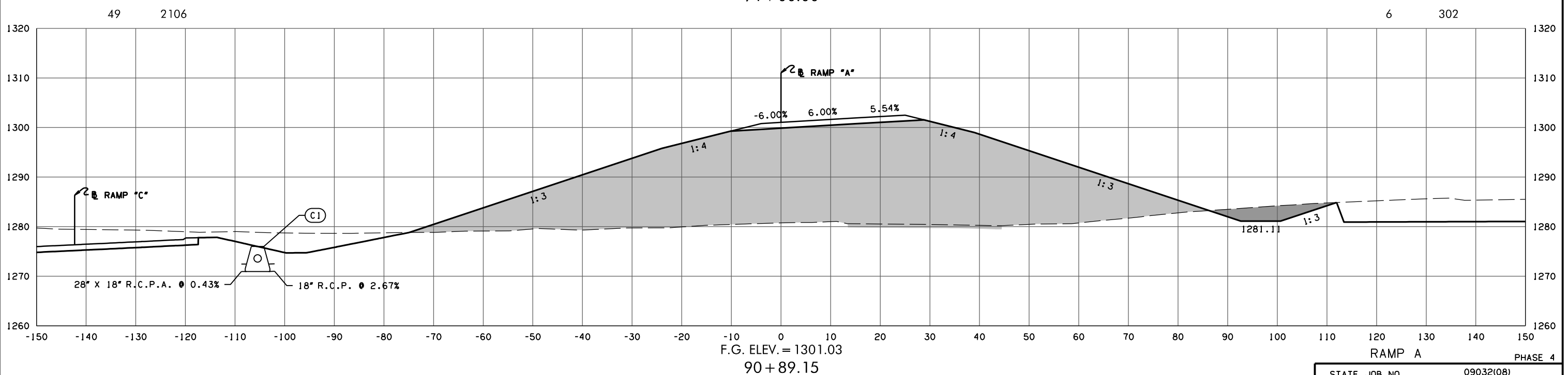
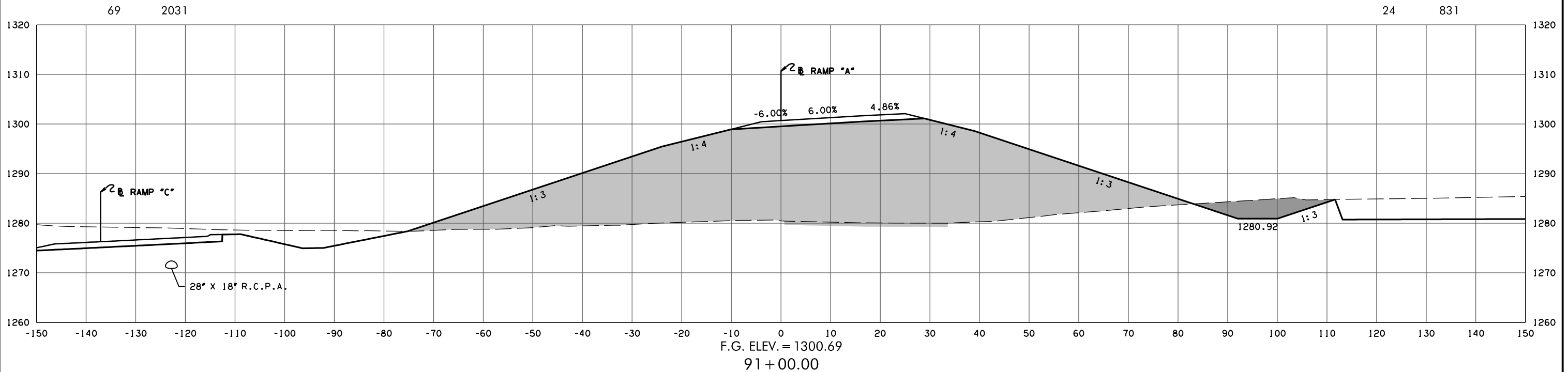

RAMP A PHASE 4

STATE JOB NO. 09032(08)

OKLAHOMA COUNTY SHEET NO. X118

3/4/2024 3:57:10 PM H:\PROJECTS\2789_CrossRoads_Phase 4\Roadway\Drawings\Sections\0903208-XSEC_Ramp_A.dgn

(CAUTION) THE LOCATION OF ALL UTILITIES AS SHOWN ARE APPROXIMATE. DUE TO RELOCATION'S PLANNED OR PRESENTLY UNDER CONSTRUCTION THERE ARE SOME UTILITIES THAT WILL BE RELOCATED AND NOT SHOWN ON THESE PLANS. THE CONTRACTOR SHALL BE RESPONSIBLE FOR ANY DAMAGE TO ALL UTILITIES.
 DEPTH & LOCATION OF EXISTING UTILITIES SHALL BE FIELD VERIFIED BY THE CONTRACTOR PRIOR TO CONSTRUCTION.

SEE DRAINAGE AREA MAP SHEETS FOR DRAINAGE SYMBOLOLOGY.

R/W & U/E PURCHASED UNDER JP 09032(05)

POB & ASSOCIATES, OKLAHOMA CITY, OK.

90% PLAN SUBMITTAL

3/4/2024

AREA
 CUT FILL

VOLUME
 CUT FILL

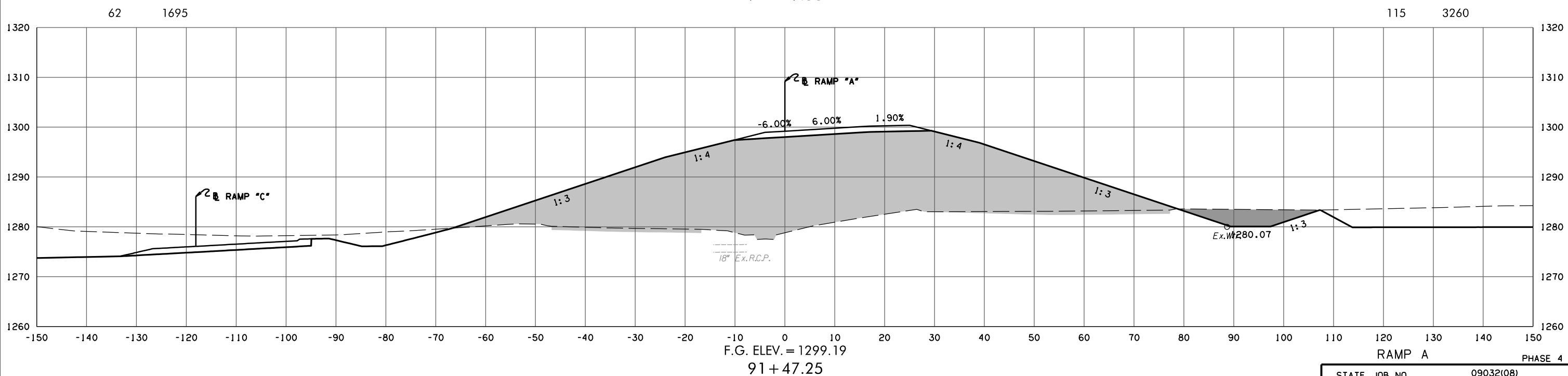
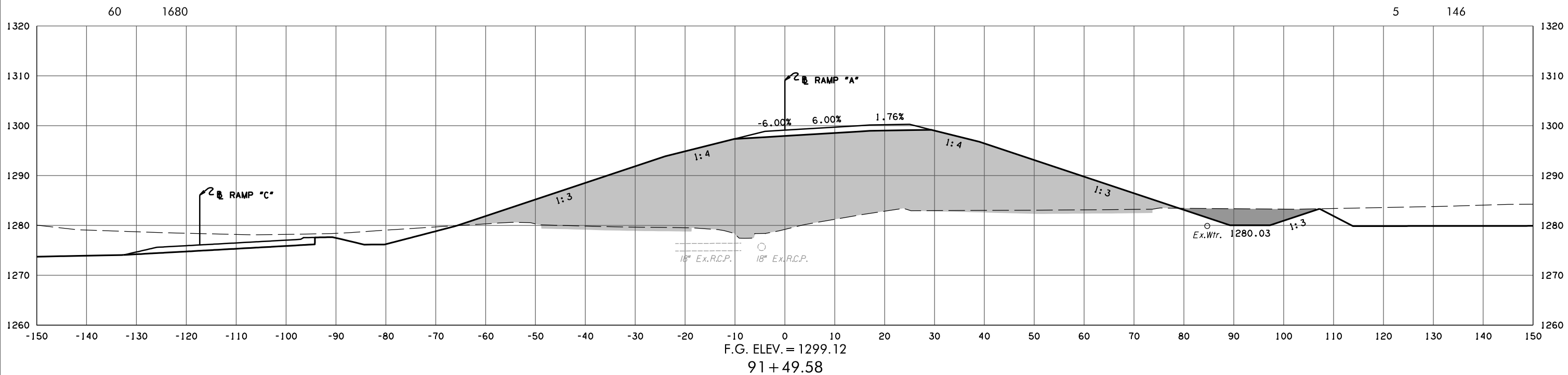

RAMP A PHASE 4

STATE JOB NO. 09032(08)

OKLAHOMA COUNTY SHEET NO. X119

3/4/2024 3:57:11 PM
 H:\PROJECTS\2789_CrossRoads_Phase 4\Roadway\Drawings\Sections\0903208-XSEC_Ramp_A.dgn

(CAUTION) THE LOCATION OF ALL UTILITIES AS SHOWN ARE APPROXIMATE. DUE TO RELOCATION'S PLANNED OR PRESENTLY UNDER CONSTRUCTION THERE ARE SOME UTILITIES THAT WILL BE RELOCATED AND NOT SHOWN ON THESE PLANS. THE CONTRACTOR SHALL BE RESPONSIBLE FOR ANY DAMAGE TO ALL UTILITIES.

DEPTH & LOCATION OF EXISTING UTILITIES SHALL BE FIELD VERIFIED BY THE CONTRACTOR PRIOR TO CONSTRUCTION.

SEE DRAINAGE AREA MAP SHEETS FOR DRAINAGE SYMBOLOLOGY.

R/W & U/E PURCHASED UNDER JP 09032(05)

POB & ASSOCIATES, OKLAHOMA CITY, OK.

**90% PLAN
SUBMITTAL**

3/4/2024

AREA
CUT FILL

VOLUME
CUT FILL

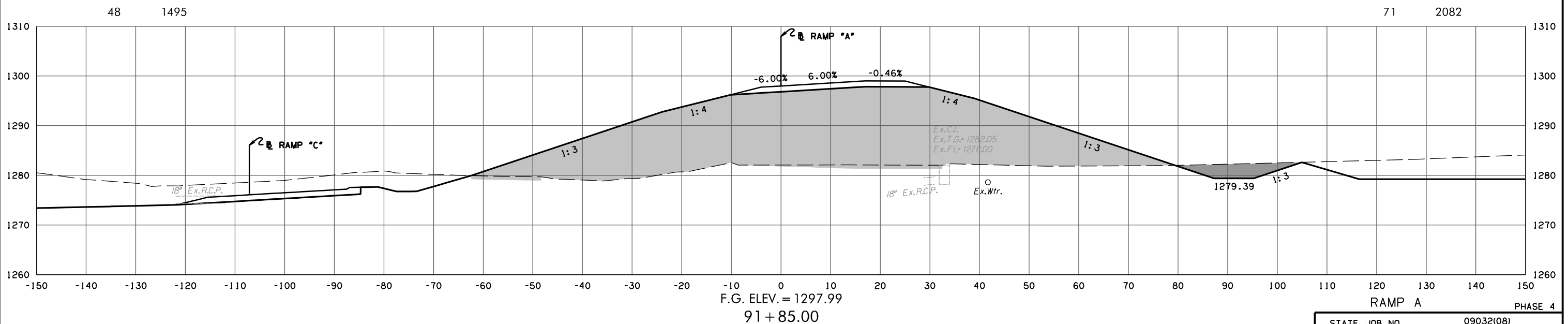
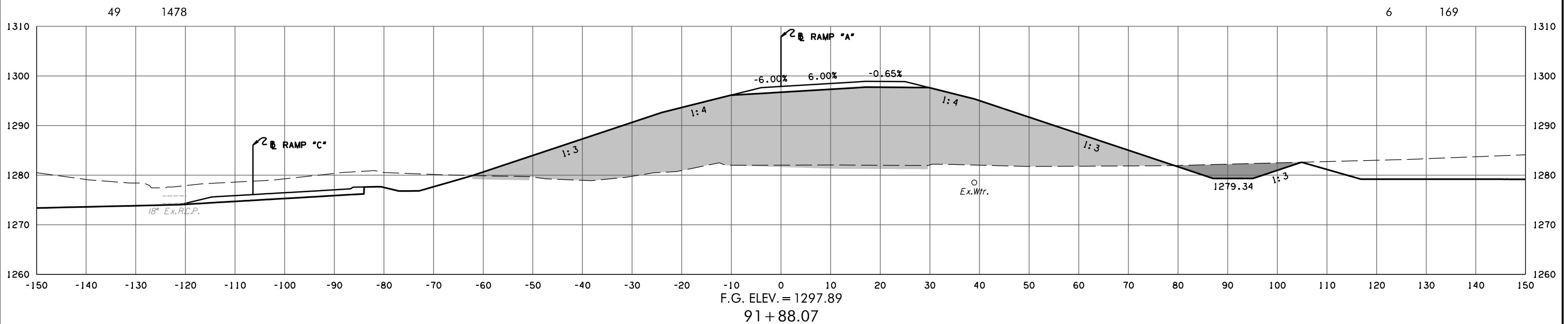

RAMP A PHASE 4

STATE JOB NO. 09032(08)
OKLAHOMA COUNTY SHEET NO. X120

3/4/2024 3:57:42 PM H:\PROJECTS\2789_CrossRoads_Phase 4\Roadway\Drawings\Sections\0903208-XSEC_Ramp_A.dgn

(CAUTION) THE LOCATION OF ALL UTILITIES AS SHOWN ARE APPROXIMATE. DUE TO RELOCATION'S PLANNED OR PRESENTLY UNDER CONSTRUCTION THERE ARE SOME UTILITIES THAT WILL BE RELOCATED AND NOT SHOWN ON THESE PLANS. THE CONTRACTOR SHALL BE RESPONSIBLE FOR ANY DAMAGE TO ALL UTILITIES.

DEPTH & LOCATION OF EXISTING UTILITIES SHALL BE FIELD VERIFIED BY THE CONTRACTOR PRIOR TO CONSTRUCTION.

SEE DRAINAGE AREA MAP SHEETS FOR DRAINAGE SYMBOLOLOGY.

R/W & U/E PURCHASED UNDER JP 09032(05)

POB & ASSOCIATES, OKLAHOMA CITY, OK.

**90% PLAN
SUBMITTAL**

3/4/2024

AREA
CUT FILL

VOLUME
CUT FILL

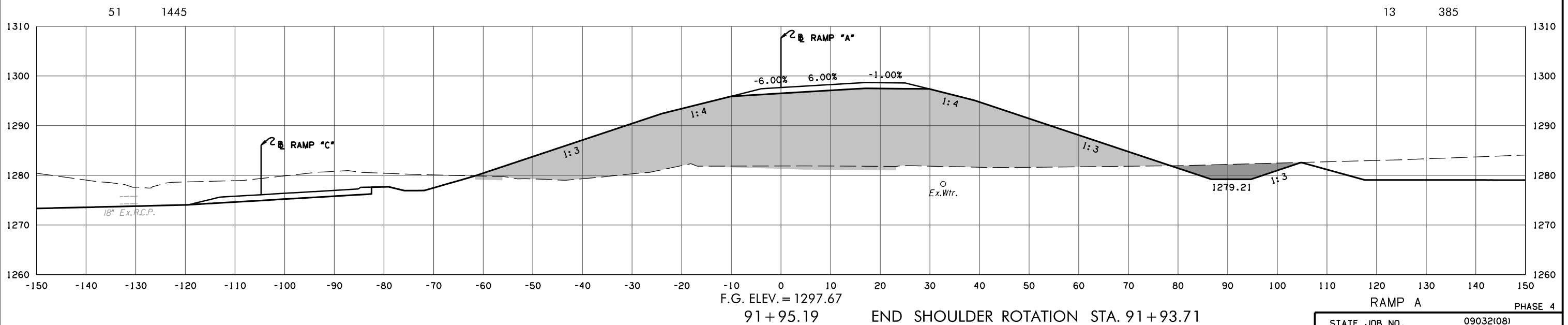
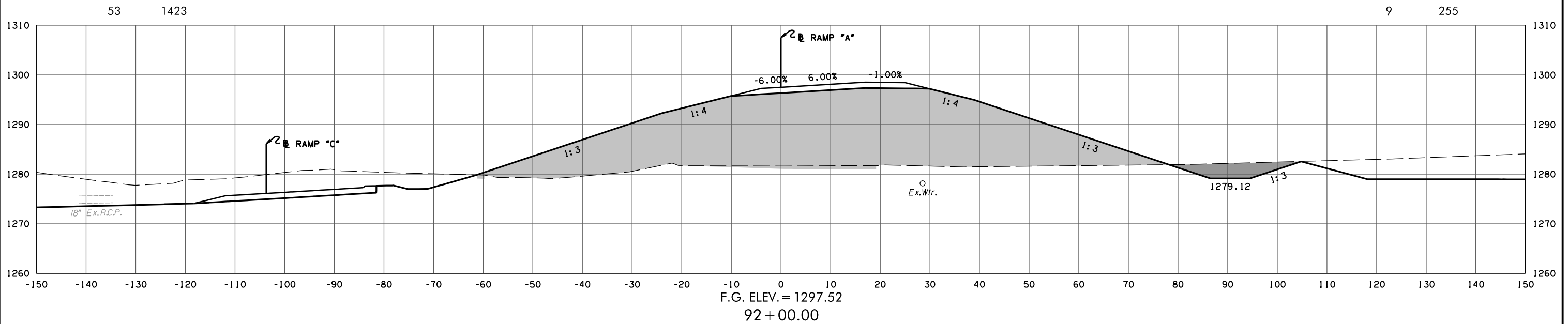

END SHOULDER ROTATION STA. 91+93.71

STATE JOB NO.	09032(08)
OKLAHOMA COUNTY	SHEET NO. X121

3/4/2024 3:57:13 PM H:\PROJECTS\2789_CrossRoads_Phase 4\Roadway\Drawings\Sections\0903208-XSEC_Ramp_A.dgn

(CAUTION) THE LOCATION OF ALL UTILITIES AS SHOWN ARE APPROXIMATE. DUE TO RELOCATION'S PLANNED OR PRESENTLY UNDER CONSTRUCTION THERE ARE SOME UTILITIES THAT WILL BE RELOCATED AND NOT SHOWN ON THESE PLANS. THE CONTRACTOR SHALL BE RESPONSIBLE FOR ANY DAMAGE TO ALL UTILITIES.
 DEPTH & LOCATION OF EXISTING UTILITIES SHALL BE FIELD VERIFIED BY THE CONTRACTOR PRIOR TO CONSTRUCTION.

SEE DRAINAGE AREA MAP SHEETS FOR DRAINAGE SYMBOLOLOGY.

R/W & U/E PURCHASED UNDER JP 09032(05)

POB & ASSOCIATES, OKLAHOMA CITY, OK.
90% PLAN SUBMITTAL
 3/4/2024

AREA
 CUT FILL

VOLUME
 CUT FILL

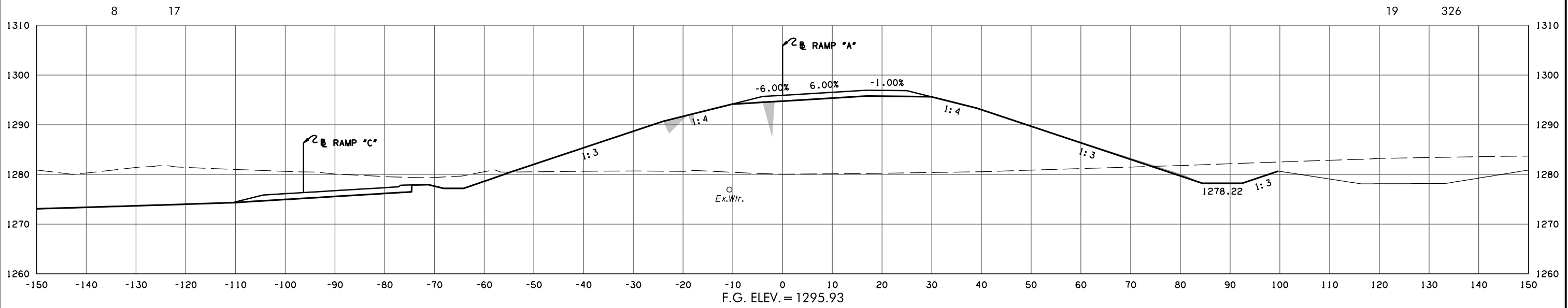

F.G. ELEV. = 1295.93
 92 + 50.00
 END CONSTRUCTION END FULL SUPER ROTATION

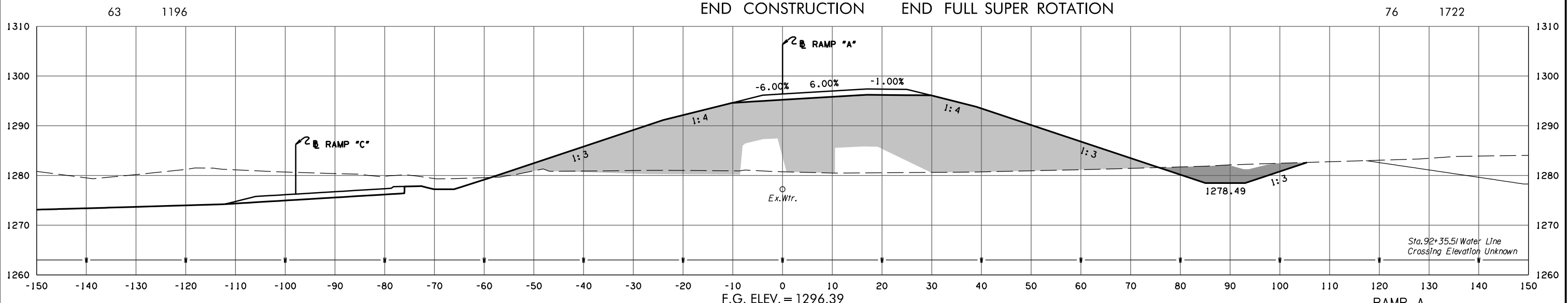

F.G. ELEV. = 1296.39
 92 + 35.51
 RAMP A PHASE 4

STATE JOB NO. 09032(08)
 OKLAHOMA COUNTY SHEET NO. X122

3/4/2024 3:57:14 PM
 H:\PROJECTS\2789_CrossRoads_Phase 4\Roadway\Drawings\Sections\0903208-XSEC_Ramp_A.dgn

(CAUTION) THE LOCATION OF ALL UTILITIES AS SHOWN ARE APPROXIMATE. DUE TO RELOCATION'S PLANNED OR PRESENTLY UNDER CONSTRUCTION THERE ARE SOME UTILITIES THAT WILL BE RELOCATED AND NOT SHOWN ON THESE PLANS. THE CONTRACTOR SHALL BE RESPONSIBLE FOR ANY DAMAGE TO ALL UTILITIES.
 DEPTH & LOCATION OF EXISTING UTILITIES SHALL BE FIELD VERIFIED BY THE CONTRACTOR PRIOR TO CONSTRUCTION.

SEE DRAINAGE AREA MAP SHEETS FOR DRAINAGE SYMBOLOLOGY.

R/W & U/E PURCHASED UNDER JP 09032(05)

POB & ASSOCIATES, OKLAHOMA CITY, OK.
90% PLAN SUBMITTAL
 3/4/2024

AREA
 CUT FILL

VOLUME
 CUT FILL

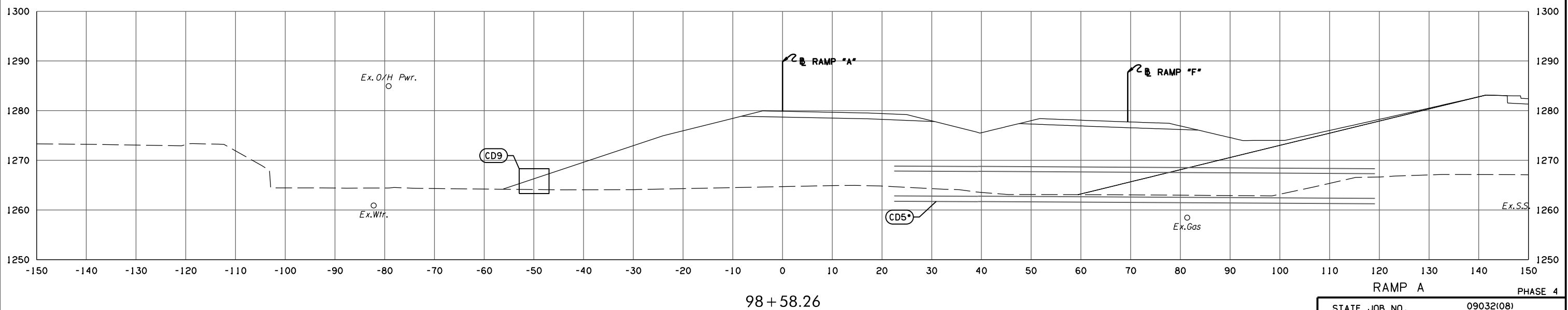
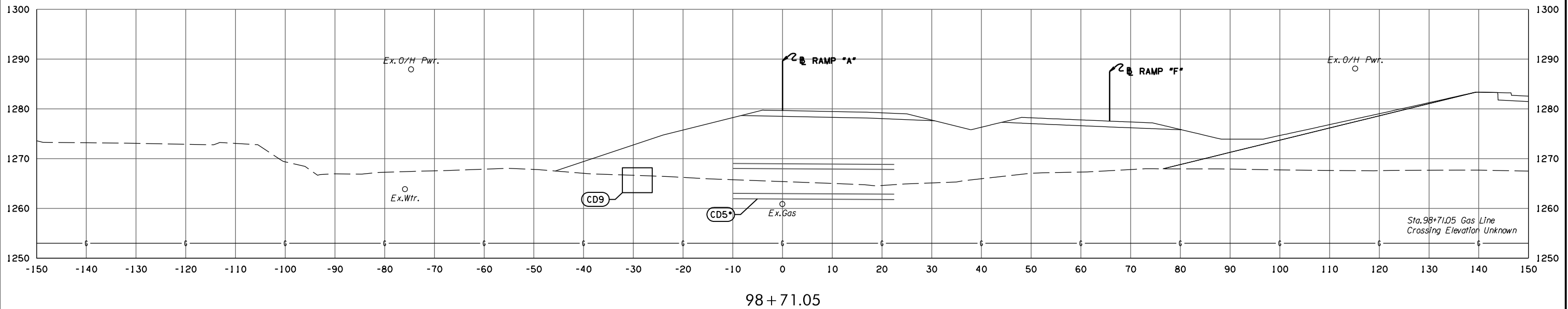

3/4/2024 3:57:14 PM H:\PROJECTS\2789_CrossRoads_Phase 4\Roadway\Drawings\Sections\0903208-XSEC_Ramp_A.dgn

RAMP A PHASE 4
 STATE JOB NO. 09032(08)
 OKLAHOMA COUNTY SHEET NO. X123

(CAUTION) THE LOCATION OF ALL UTILITIES AS SHOWN ARE APPROXIMATE. DUE TO RELOCATION'S PLANNED OR PRESENTLY UNDER CONSTRUCTION THERE ARE SOME UTILITIES THAT WILL BE RELOCATED AND NOT SHOWN ON THESE PLANS. THE CONTRACTOR SHALL BE RESPONSIBLE FOR ANY DAMAGE TO ALL UTILITIES.

DEPTH & LOCATION OF EXISTING UTILITIES SHALL BE FIELD VERIFIED BY THE CONTRACTOR PRIOR TO CONSTRUCTION.

SEE DRAINAGE AREA MAP SHEETS FOR DRAINAGE SYMBOLOLOGY.

R/W & U/E PURCHASED UNDER JP 09032(05)

POB & ASSOCIATES, OKLAHOMA CITY, OK.

**90% PLAN
SUBMITTAL**

3/4/2024

AREA
CUT FILL

VOLUME
CUT FILL

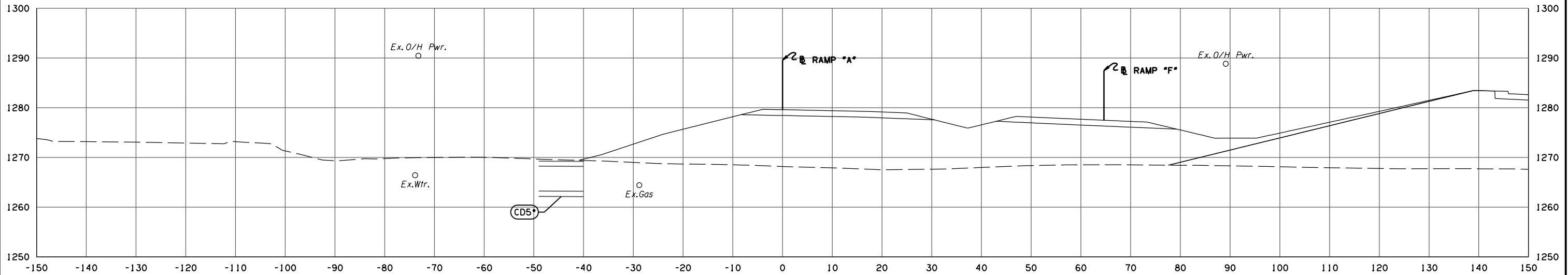

98+75.22

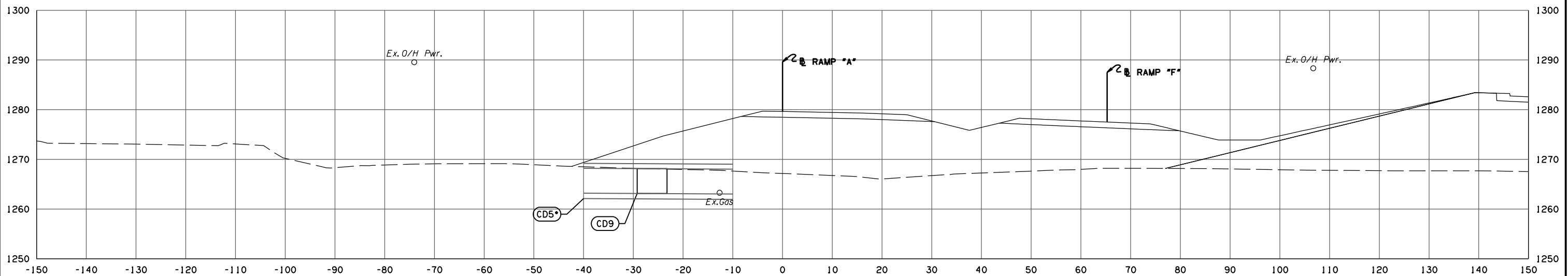

98+72.88

RAMP A PHASE 4

STATE JOB NO. 09032(08)
OKLAHOMA COUNTY SHEET NO. X124

3/4/2024 3:57:45 PM
H:\PROJECTS\2789_CrossRoads_Phase 4\Roadway\Drawings\Sections\0903208-XSEC_Ramp_A.dgn

(CAUTION) THE LOCATION OF ALL UTILITIES AS SHOWN ARE APPROXIMATE. DUE TO RELOCATION'S PLANNED OR PRESENTLY UNDER CONSTRUCTION THERE ARE SOME UTILITIES THAT WILL BE RELOCATED AND NOT SHOWN ON THESE PLANS. THE CONTRACTOR SHALL BE RESPONSIBLE FOR ANY DAMAGE TO ALL UTILITIES.
 DEPTH & LOCATION OF EXISTING UTILITIES SHALL BE FIELD VERIFIED BY THE CONTRACTOR PRIOR TO CONSTRUCTION.

SEE DRAINAGE AREA MAP SHEETS FOR DRAINAGE SYMBOLOLOGY.

R/W & U/E PURCHASED UNDER JP 09032(05)

POB & ASSOCIATES, OKLAHOMA CITY, OK.
90% PLAN SUBMITTAL
 3/4/2024

AREA
 CUT FILL

VOLUME
 CUT FILL

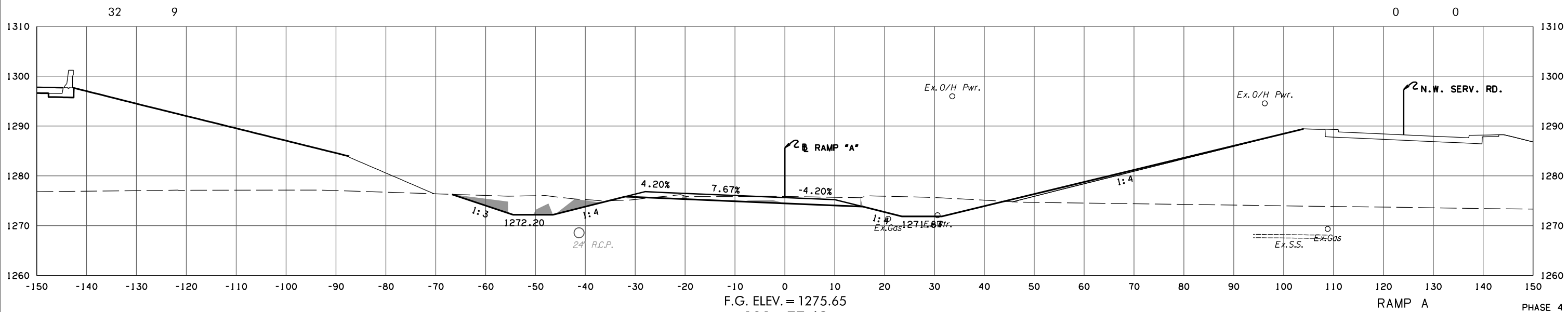
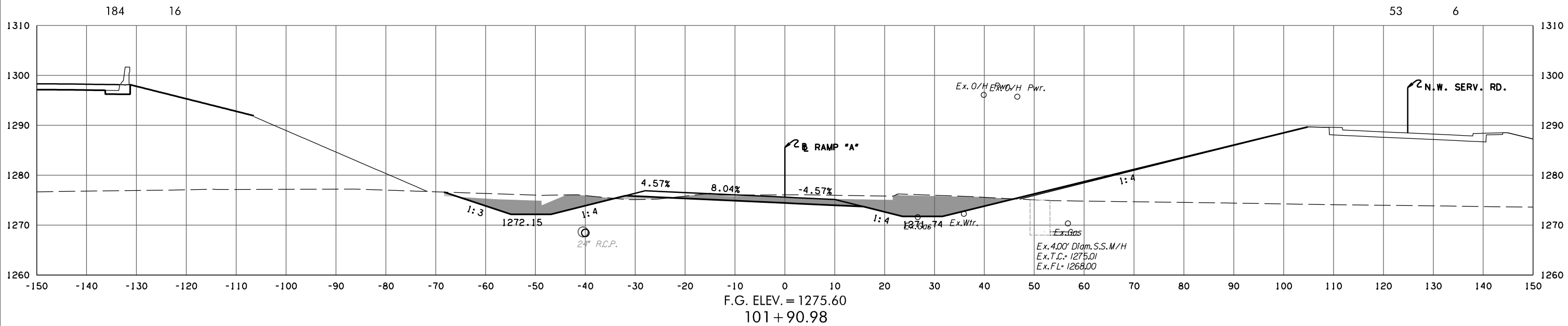

BEGIN CONSTRUCTION BEGIN SUPER ROTATION

RAMP A PHASE 4
 STATE JOB NO. 09032(08)
 OKLAHOMA COUNTY SHEET NO. X125

3/4/2024 3:57:16 PM H:\PROJECTS\2789_CrossRoads_Phase 4\Roadway\Drawings\Sections\0903208-XSEC_Ramp_A.dgn

(CAUTION) THE LOCATION OF ALL UTILITIES AS SHOWN ARE APPROXIMATE. DUE TO RELOCATION'S PLANNED OR PRESENTLY UNDER CONSTRUCTION THERE ARE SOME UTILITIES THAT WILL BE RELOCATED AND NOT SHOWN ON THESE PLANS. THE CONTRACTOR SHALL BE RESPONSIBLE FOR ANY DAMAGE TO ALL UTILITIES. DEPTH & LOCATION OF EXISTING UTILITIES SHALL BE FIELD VERIFIED BY THE CONTRACTOR PRIOR TO CONSTRUCTION.

SEE DRAINAGE AREA MAP SHEETS FOR DRAINAGE SYMBOLOLOGY.

R/W & U/E PURCHASED UNDER JP 09032(05)

POB & ASSOCIATES, OKLAHOMA CITY, OK.

90% PLAN SUBMITTAL

3/4/2024

AREA
CUT FILL

VOLUME
CUT FILL

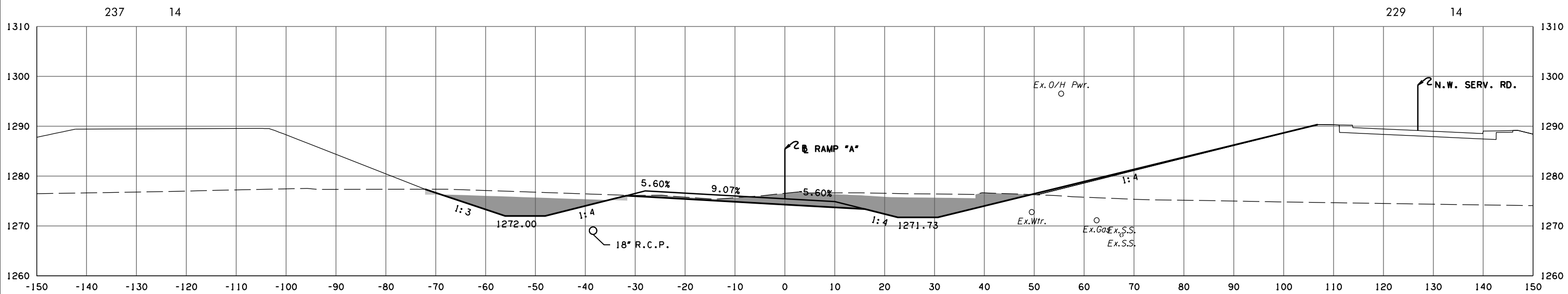

F.G. ELEV. = 1275.45

102 + 28.03

BEGIN FULL SUPER ROTATION

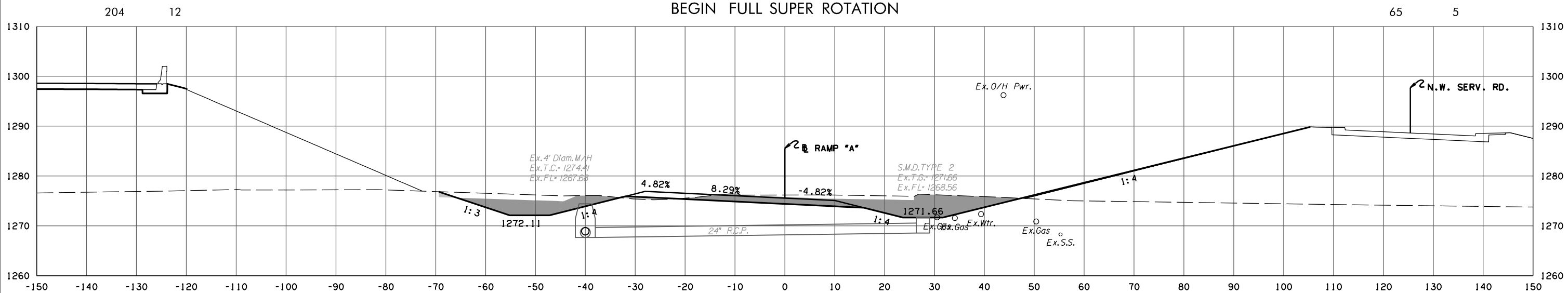

F.G. ELEV. = 1275.56

102 + 00.00

RAMP A PHASE 4

STATE JOB NO. 09032(08)
OKLAHOMA COUNTY SHEET NO. X126

3/4/2024 3:57:17 PM H:\PROJECTS\2789_CrossRoads_Phase 4\Roadway\Drawings\Sections\0903208-XSEC_Ramp_A.dgn

(CAUTION) THE LOCATION OF ALL UTILITIES AS SHOWN ARE APPROXIMATE. DUE TO RELOCATION'S PLANNED OR PRESENTLY UNDER CONSTRUCTION THERE ARE SOME UTILITIES THAT WILL BE RELOCATED AND NOT SHOWN ON THESE PLANS. THE CONTRACTOR SHALL BE RESPONSIBLE FOR ANY DAMAGE TO ALL UTILITIES.
 DEPTH & LOCATION OF EXISTING UTILITIES SHALL BE FIELD VERIFIED BY THE CONTRACTOR PRIOR TO CONSTRUCTION.

SEE DRAINAGE AREA MAP SHEETS FOR DRAINAGE SYMBOLOLOGY.

R/W & U/E PURCHASED UNDER JP 09032(05)

POB & ASSOCIATES, OKLAHOMA CITY, OK.
90% PLAN SUBMITTAL
 3/4/2024

AREA
 CUT FILL

VOLUME
 CUT FILL

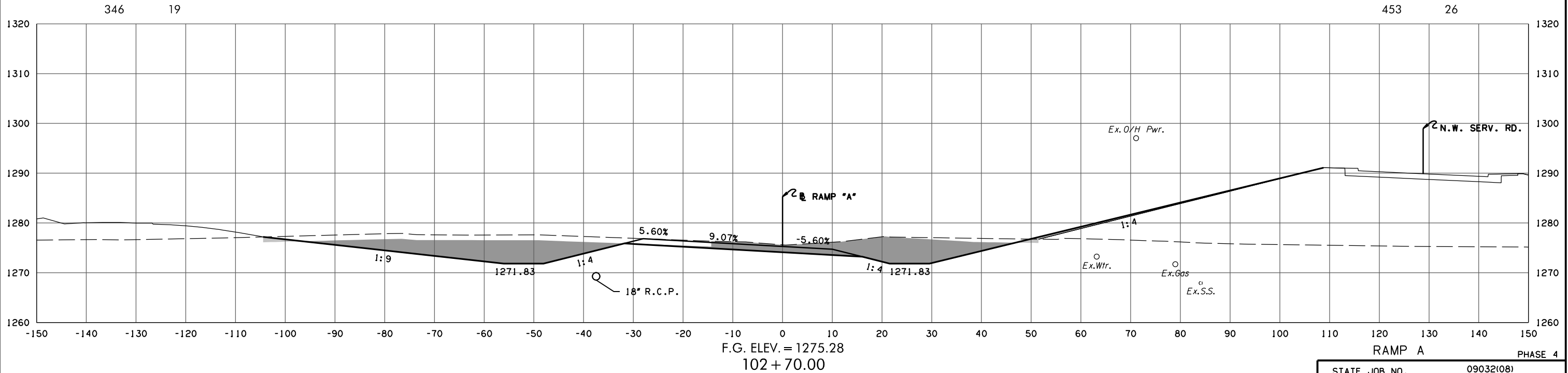
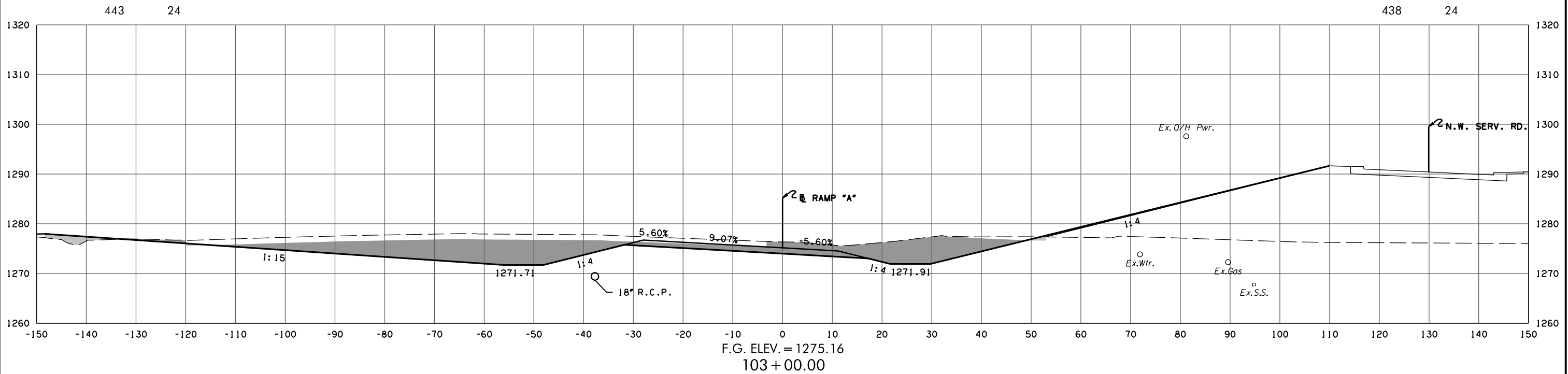

3/4/2024 3:57:18 PM H:\PROJECTS\2789_CrossRoads_Phase 4\Roadway\Drawings\Sections\0903208-XSEC_Ramp_A.dgn

RAMP A PHASE 4
 STATE JOB NO. 09032(08)
 OKLAHOMA COUNTY SHEET NO. X127

(CAUTION) THE LOCATION OF ALL UTILITIES AS SHOWN ARE APPROXIMATE. DUE TO RELOCATION'S PLANNED OR PRESENTLY UNDER CONSTRUCTION THERE ARE SOME UTILITIES THAT WILL BE RELOCATED AND NOT SHOWN ON THESE PLANS. THE CONTRACTOR SHALL BE RESPONSIBLE FOR ANY DAMAGE TO ALL UTILITIES.

SEE DRAINAGE AREA MAP SHEETS FOR DRAINAGE SYMBOLOLOGY.

R/W & U/E PURCHASED UNDER JP 09032(05)

POB & ASSOCIATES, OKLAHOMA CITY, OK.

**90% PLAN
SUBMITTAL**

3/4/2024

AREA
CUT FILL

VOLUME
CUT FILL

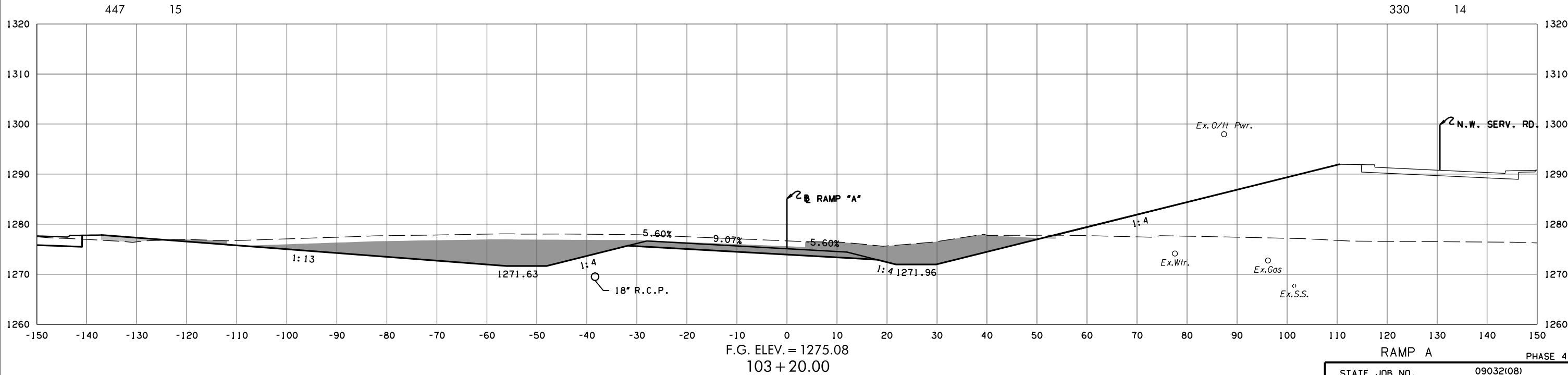
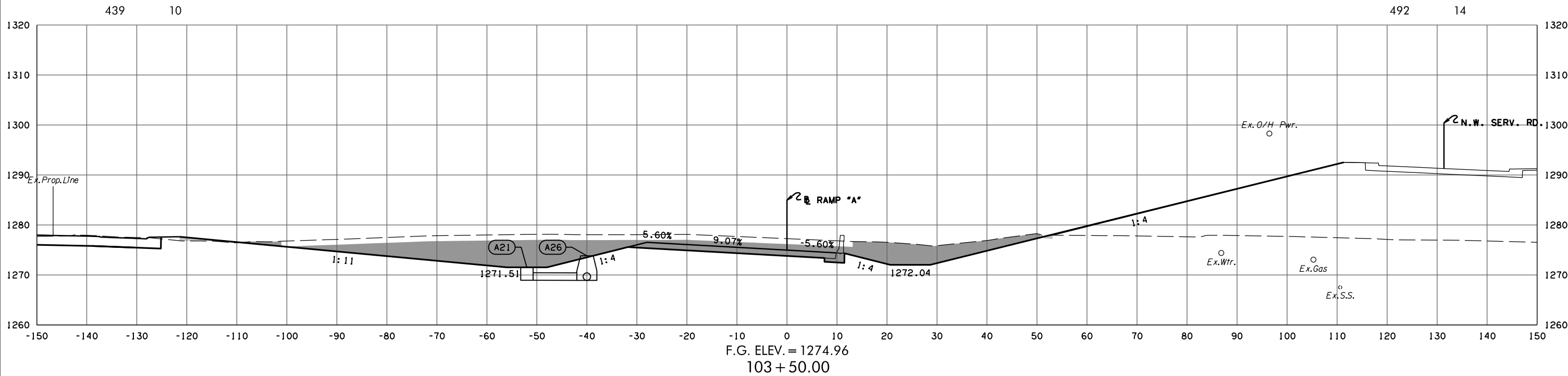

3/4/2024 3:57:18 PM H:\PROJECTS\2789_CrossRoads_Phase 4\Roadway\Drawings\Sections\0903208-XSEC_Ramp_A.dgn

RAMP A PHASE 4

STATE JOB NO. 09032(08)
OKLAHOMA COUNTY SHEET NO. X128

(CAUTION) THE LOCATION OF ALL UTILITIES AS SHOWN ARE APPROXIMATE. DUE TO RELOCATION'S PLANNED OR PRESENTLY UNDER CONSTRUCTION THERE ARE SOME UTILITIES THAT WILL BE RELOCATED AND NOT SHOWN ON THESE PLANS. THE CONTRACTOR SHALL BE RESPONSIBLE FOR ANY DAMAGE TO ALL UTILITIES.

DEPTH & LOCATION OF EXISTING UTILITIES SHALL BE FIELD VERIFIED BY THE CONTRACTOR PRIOR TO CONSTRUCTION.

SEE DRAINAGE AREA MAP SHEETS FOR DRAINAGE SYMBOLOLOGY.

R/W & U/E PURCHASED UNDER JP 09032(05)

POB & ASSOCIATES, OKLAHOMA CITY, OK.

**90% PLAN
SUBMITTAL**

3/4/2024

AREA
CUT FILL

VOLUME
CUT FILL

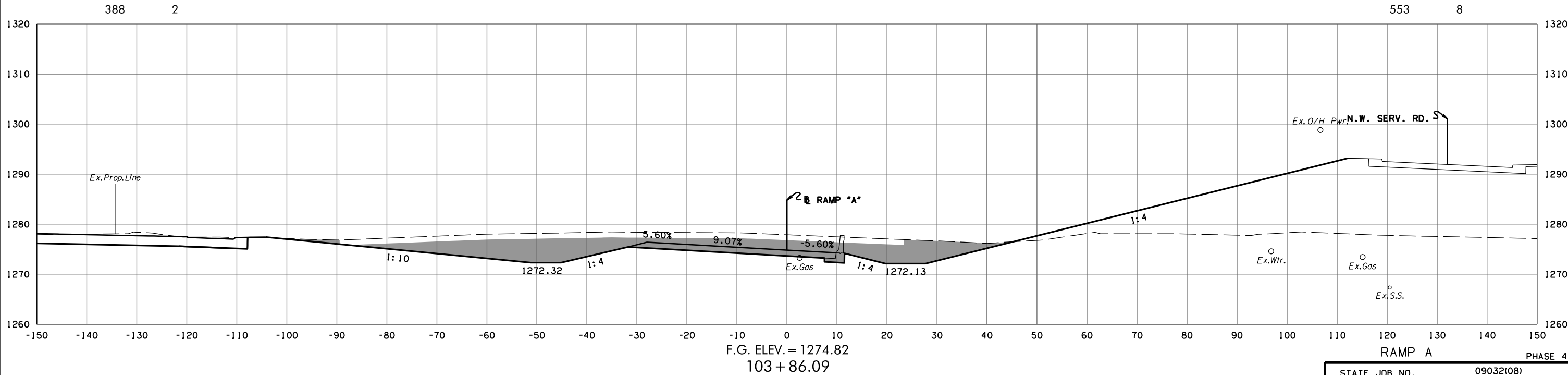
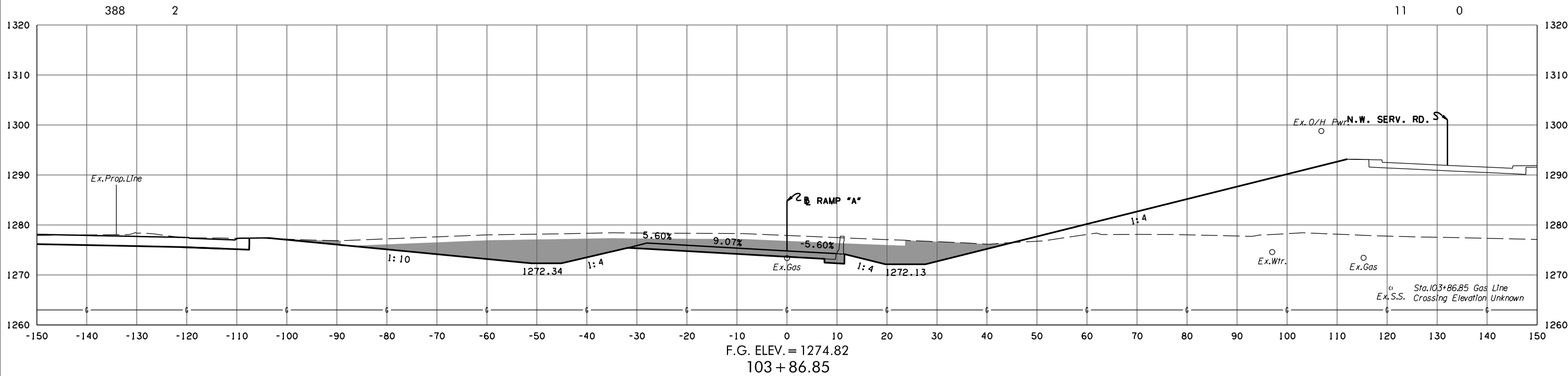

STATE JOB NO. 09032(08)
OKLAHOMA COUNTY SHEET NO. X129

3/4/2024 3:57:19 PM H:\PROJECTS\2789_CrossRoads_Phase 4\Roadway\Drawings\Sections\0903208-XSEC_Ramp_A.dgn

(CAUTION) THE LOCATION OF ALL UTILITIES AS SHOWN ARE APPROXIMATE. DUE TO RELOCATION'S PLANNED OR PRESENTLY UNDER CONSTRUCTION THERE ARE SOME UTILITIES THAT WILL BE RELOCATED AND NOT SHOWN ON THESE PLANS. THE CONTRACTOR SHALL BE RESPONSIBLE FOR ANY DAMAGE TO ALL UTILITIES.
 DEPTH & LOCATION OF EXISTING UTILITIES SHALL BE FIELD VERIFIED BY THE CONTRACTOR PRIOR TO CONSTRUCTION.

SEE DRAINAGE AREA MAP SHEETS FOR DRAINAGE SYMBOLOLOGY.

R/W & U/E PURCHASED UNDER JP 09032(05)

POB & ASSOCIATES, OKLAHOMA CITY, OK.
90% PLAN SUBMITTAL
 3/4/2024

AREA
 CUT FILL

VOLUME
 CUT FILL

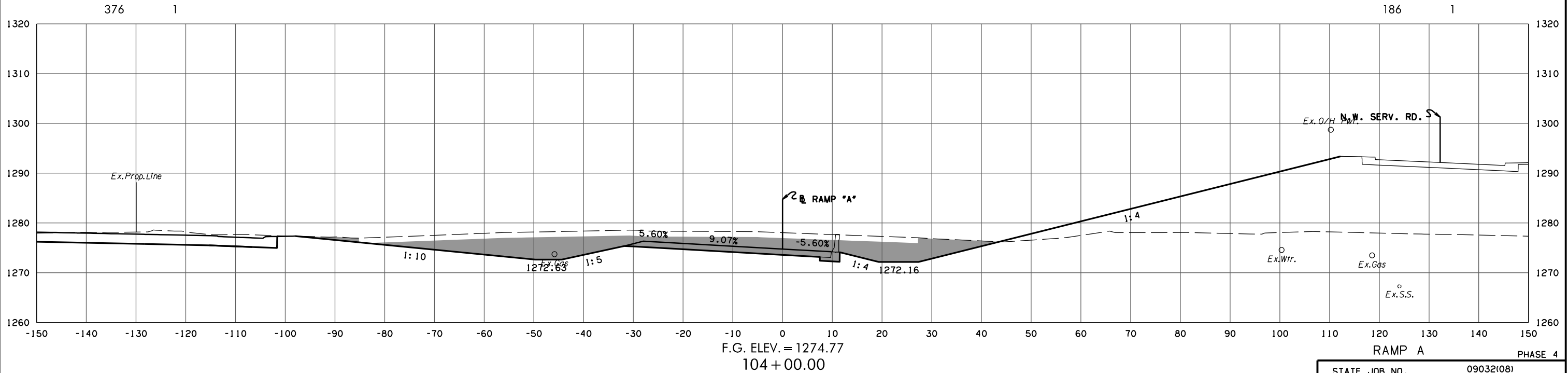
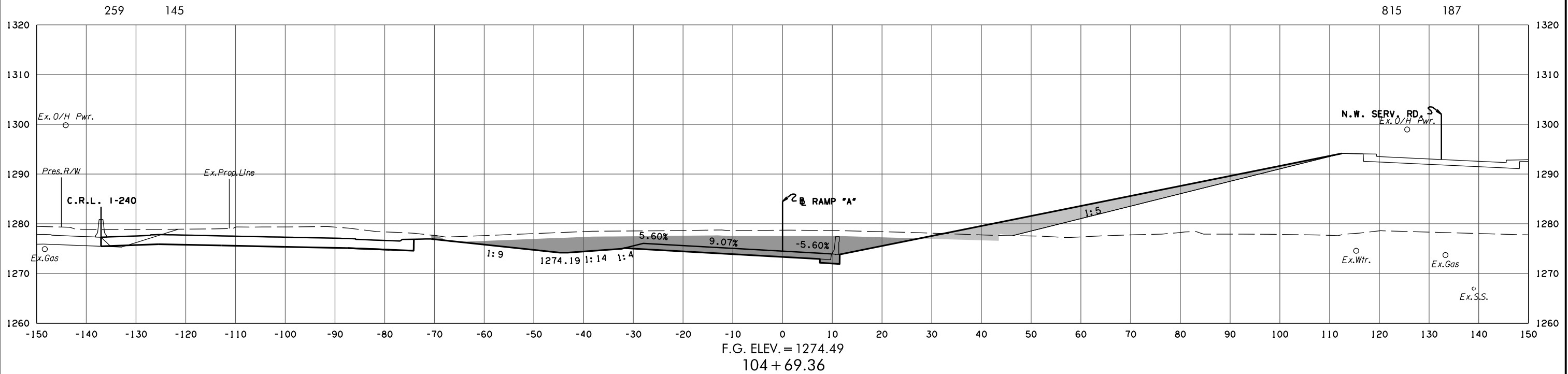

RAMP A PHASE 4
 STATE JOB NO. 09032(08)
 OKLAHOMA COUNTY SHEET NO. X130

3/4/2024 3:57:20 PM
 H:\PROJECTS\2789_CrossRoads_Phase 4\Roadway\Drawings\Sections\0903208-XSEC_Ramp_A.dgn

(CAUTION) THE LOCATION OF ALL UTILITIES AS SHOWN ARE APPROXIMATE. DUE TO RELOCATION'S PLANNED OR PRESENTLY UNDER CONSTRUCTION THERE ARE SOME UTILITIES THAT WILL BE RELOCATED AND NOT SHOWN ON THESE PLANS. THE CONTRACTOR SHALL BE RESPONSIBLE FOR ANY DAMAGE TO ALL UTILITIES.
 DEPTH & LOCATION OF EXISTING UTILITIES SHALL BE FIELD VERIFIED BY THE CONTRACTOR PRIOR TO CONSTRUCTION.

SEE DRAINAGE AREA MAP SHEETS FOR DRAINAGE SYMBOLOLOGY.

R/W & U/E PURCHASED UNDER JP 09032(05)

POB & ASSOCIATES, OKLAHOMA CITY, OK.
90% PLAN SUBMITTAL
 3/4/2024

AREA
 CUT FILL

VOLUME
 CUT FILL

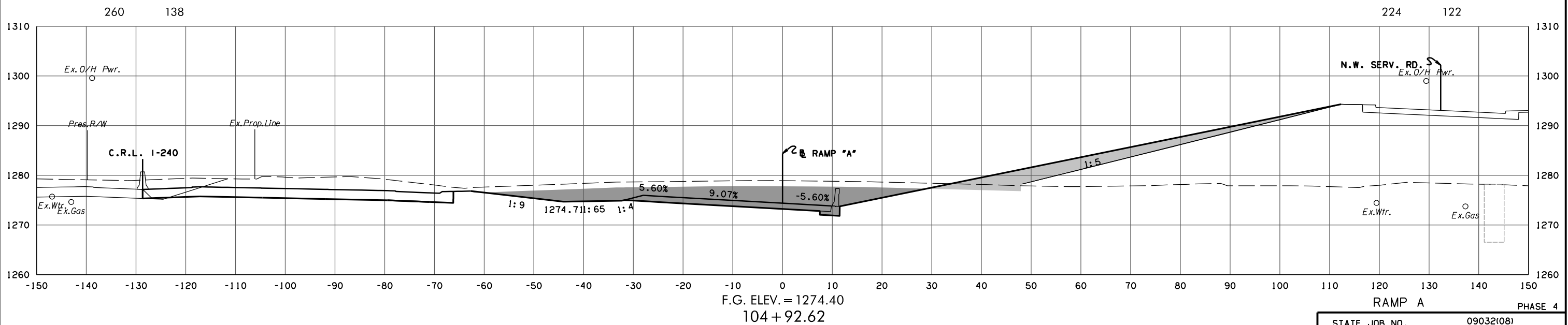
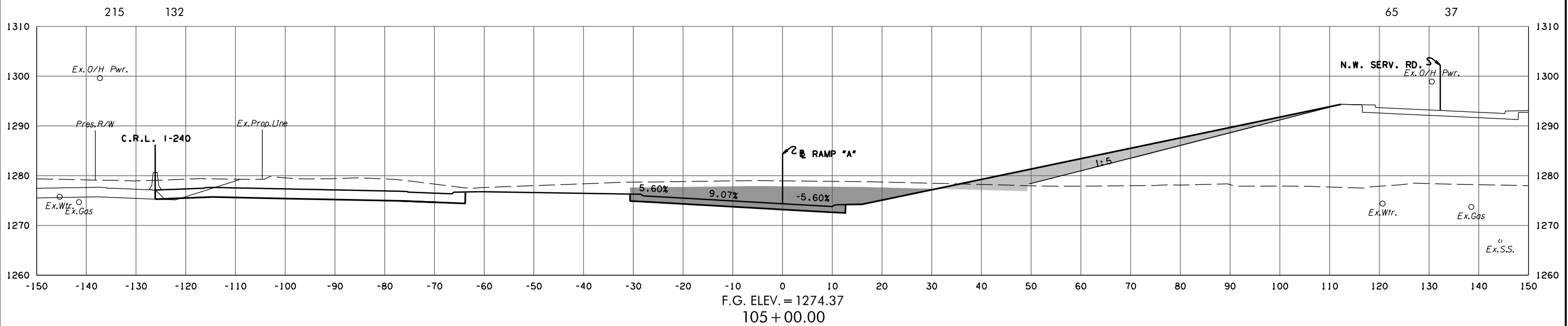

3/4/2024 3:57:21 PM
 H:\PROJECTS\2789_CrossRoads_Phase 4\Roadway\Drawings\Sections\0903208-XSEC_Ramp_A.dgn

STATE JOB NO. 09032(08)
 OKLAHOMA COUNTY SHEET NO. X131

(CAUTION) THE LOCATION OF ALL UTILITIES AS SHOWN ARE APPROXIMATE. DUE TO RELOCATION'S PLANNED OR PRESENTLY UNDER CONSTRUCTION THERE ARE SOME UTILITIES THAT WILL BE RELOCATED AND NOT SHOWN ON THESE PLANS. THE CONTRACTOR SHALL BE RESPONSIBLE FOR ANY DAMAGE TO ALL UTILITIES.
 DEPTH & LOCATION OF EXISTING UTILITIES SHALL BE FIELD VERIFIED BY THE CONTRACTOR PRIOR TO CONSTRUCTION.

SEE DRAINAGE AREA MAP SHEETS FOR DRAINAGE SYMBOLOLOGY.

R/W & U/E PURCHASED UNDER JP 09032(05)

POB & ASSOCIATES, OKLAHOMA CITY, OK.
90% PLAN SUBMITTAL
 3/4/2024

AREA
 CUT FILL

VOLUME
 CUT FILL

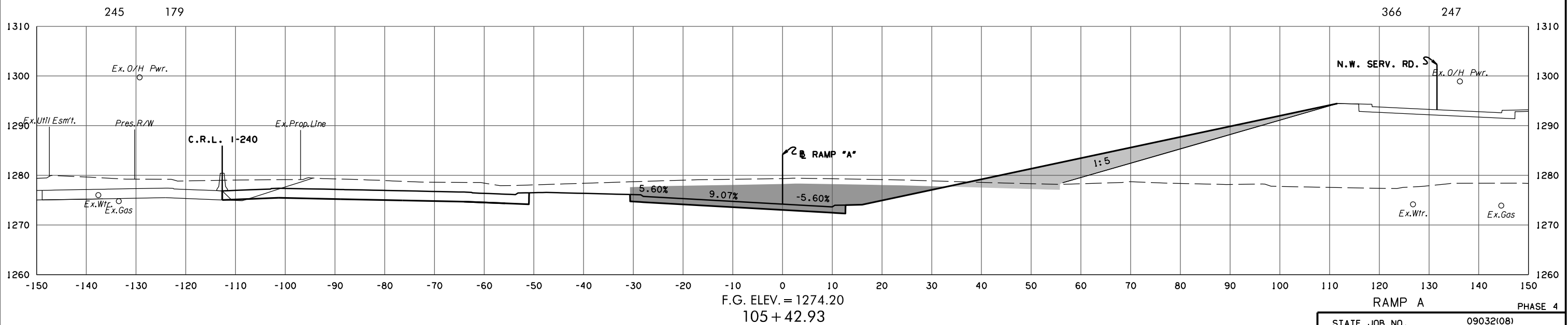
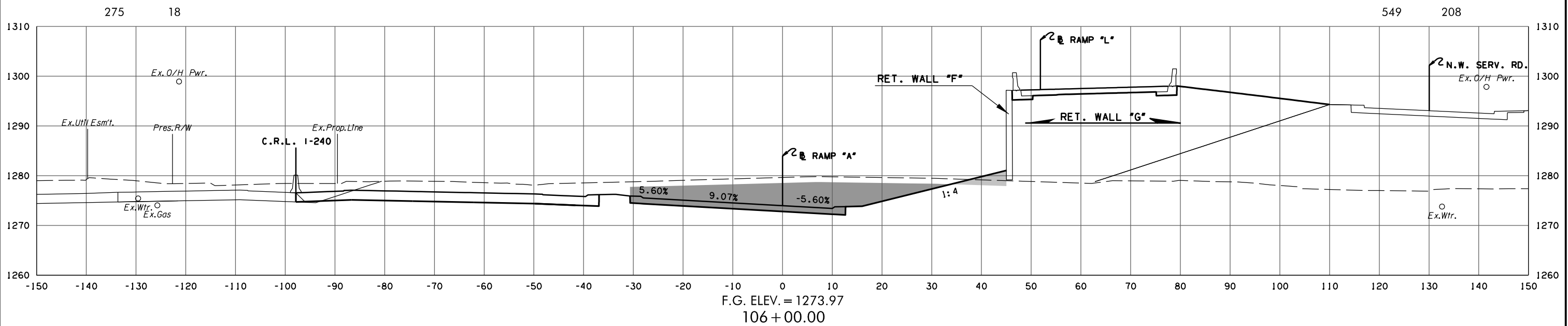

3/4/2024 3:57:22 PM
 H:\PROJECTS\2789_CrossRoads_Phase 4\Roadway\Drawings\Sections\0903208-XSEC_Ramp_A.dgn

STATE JOB NO. 09032(08)
 OKLAHOMA COUNTY SHEET NO. X132

(CAUTION) THE LOCATION OF ALL UTILITIES AS SHOWN ARE APPROXIMATE. DUE TO RELOCATION'S PLANNED OR PRESENTLY UNDER CONSTRUCTION THERE ARE SOME UTILITIES THAT WILL BE RELOCATED AND NOT SHOWN ON THESE PLANS. THE CONTRACTOR SHALL BE RESPONSIBLE FOR ANY DAMAGE TO ALL UTILITIES.
 DEPTH & LOCATION OF EXISTING UTILITIES SHALL BE FIELD VERIFIED BY THE CONTRACTOR PRIOR TO CONSTRUCTION.

SEE DRAINAGE AREA MAP SHEETS FOR DRAINAGE SYMBOLOLOGY.

R/W & U/E PURCHASED UNDER JP 09032(05)

POB & ASSOCIATES, OKLAHOMA CITY, OK.
90% PLAN SUBMITTAL
 3/4/2024

AREA
 CUT FILL

VOLUME
 CUT FILL

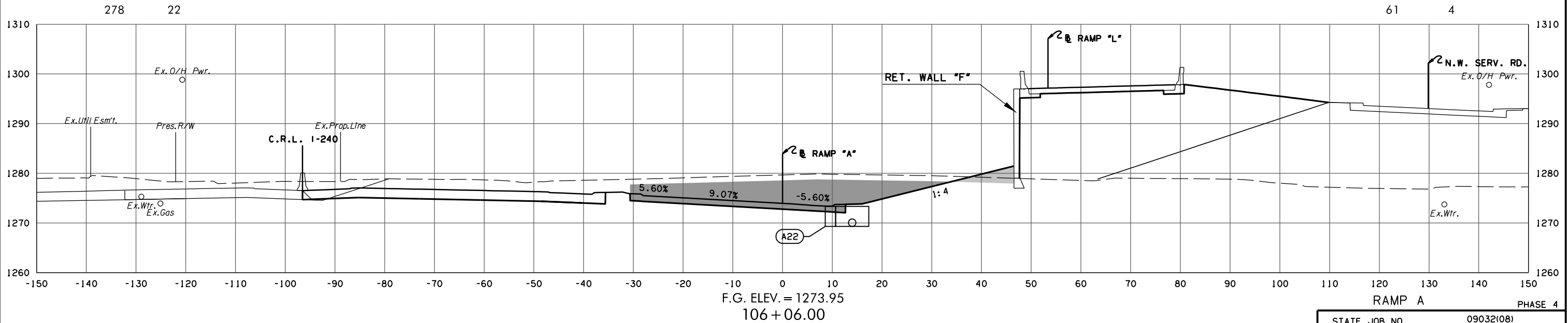
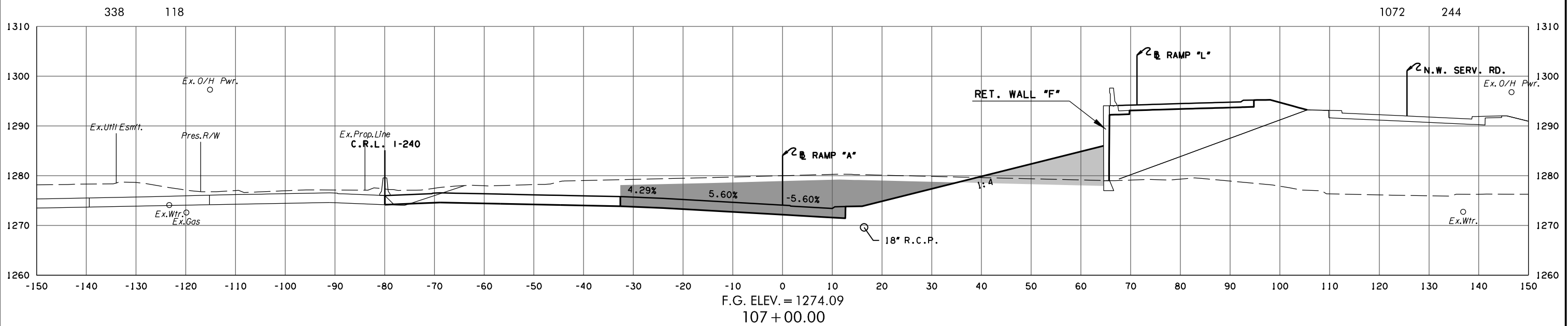

3/4/2024 3:57:23 PM H:\PROJECTS\2785_CrossRoads_Phase 4\Roadway\Drawings\Sections\0903208-XSEC_Ramp_A.dgn

STATE JOB NO. 09032(08)
 OKLAHOMA COUNTY SHEET NO. X133

(CAUTION) THE LOCATION OF ALL UTILITIES AS SHOWN ARE APPROXIMATE. DUE TO RELOCATION'S PLANNED OR PRESENTLY UNDER CONSTRUCTION THERE ARE SOME UTILITIES THAT WILL BE RELOCATED AND NOT SHOWN ON THESE PLANS. THE CONTRACTOR SHALL BE RESPONSIBLE FOR ANY DAMAGE TO ALL UTILITIES. DEPTH & LOCATION OF EXISTING UTILITIES SHALL BE FIELD VERIFIED BY THE CONTRACTOR PRIOR TO CONSTRUCTION.

SEE DRAINAGE AREA MAP SHEETS FOR DRAINAGE SYMBOLOLOGY.

R/W & U/E PURCHASED UNDER JP 09032(05)

POB & ASSOCIATES, OKLAHOMA CITY, OK.

**90% PLAN
SUBMITTAL**

3/4/2024

AREA
CUT FILL

VOLUME
CUT FILL

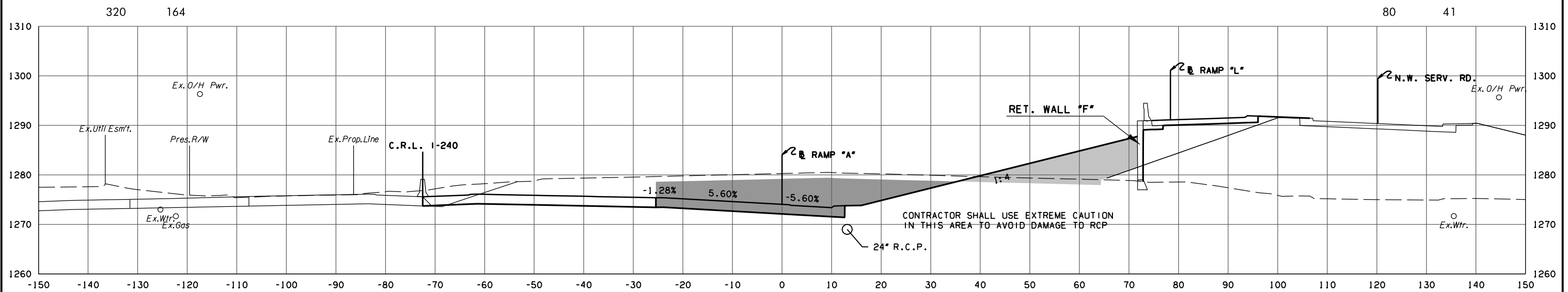

F.G. ELEV. = 1274.05
107+81.71
END FULL SUPER ROTATION

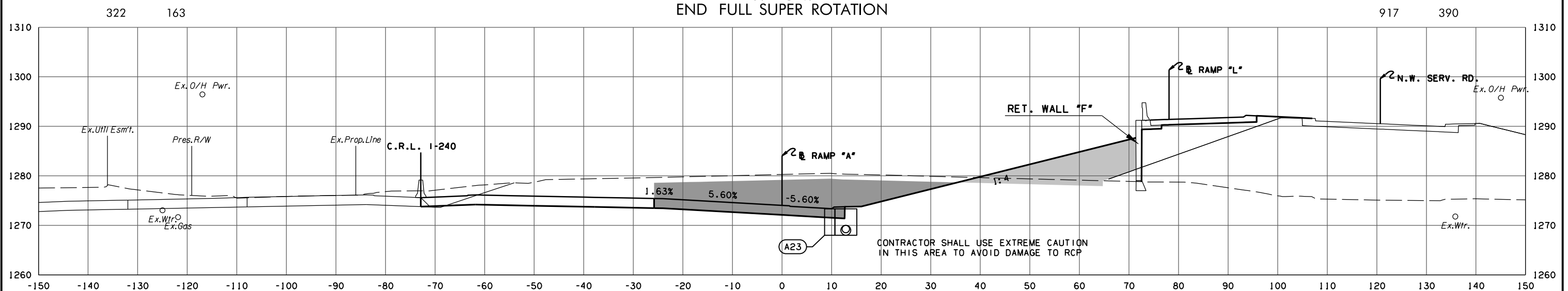

F.G. ELEV. = 1274.04
107+75.00

RAMP A PHASE 4

STATE JOB NO. 09032(08)
OKLAHOMA COUNTY SHEET NO. X134

3/4/2024 3:57:23 PM H:\PROJECTS\2789_CrossRoads_Phase 4\Roadway\Drawings\Sections\0903208-XSEC_Ramp_A.dgn

(CAUTION) THE LOCATION OF ALL UTILITIES AS SHOWN ARE APPROXIMATE. DUE TO RELOCATION'S PLANNED OR PRESENTLY UNDER CONSTRUCTION THERE ARE SOME UTILITIES THAT WILL BE RELOCATED AND NOT SHOWN ON THESE PLANS. THE CONTRACTOR SHALL BE RESPONSIBLE FOR ANY DAMAGE TO ALL UTILITIES.

DEPTH & LOCATION OF EXISTING UTILITIES SHALL BE FIELD VERIFIED BY THE CONTRACTOR PRIOR TO CONSTRUCTION.

SEE DRAINAGE AREA MAP SHEETS FOR DRAINAGE SYMBOLOLOGY.

R/W & U/E PURCHASED UNDER JP 09032(05)

POB & ASSOCIATES, OKLAHOMA CITY, OK.

**90% PLAN
SUBMITTAL**

3/4/2024

AREA
CUT FILL

VOLUME
CUT FILL

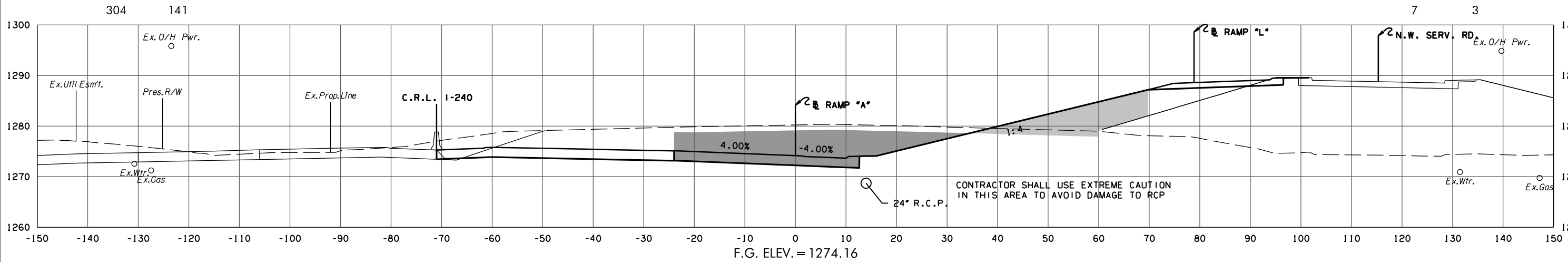

F.G. ELEV. = 1274.16
108 + 39.30

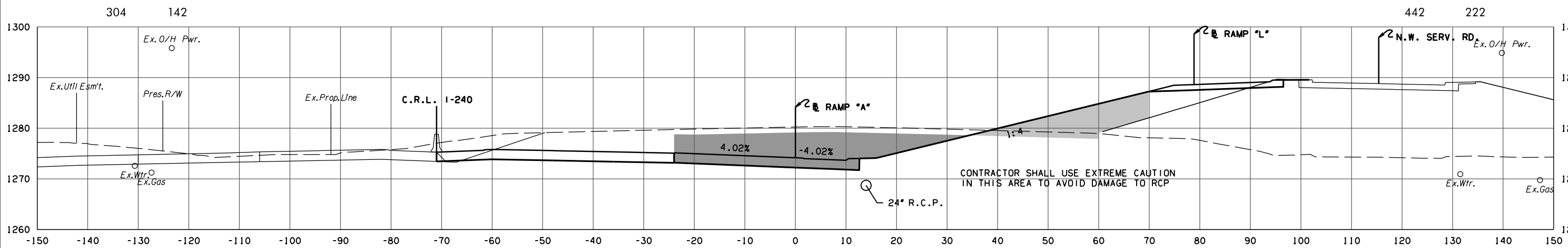

F.G. ELEV. = 1274.16
108 + 38.64

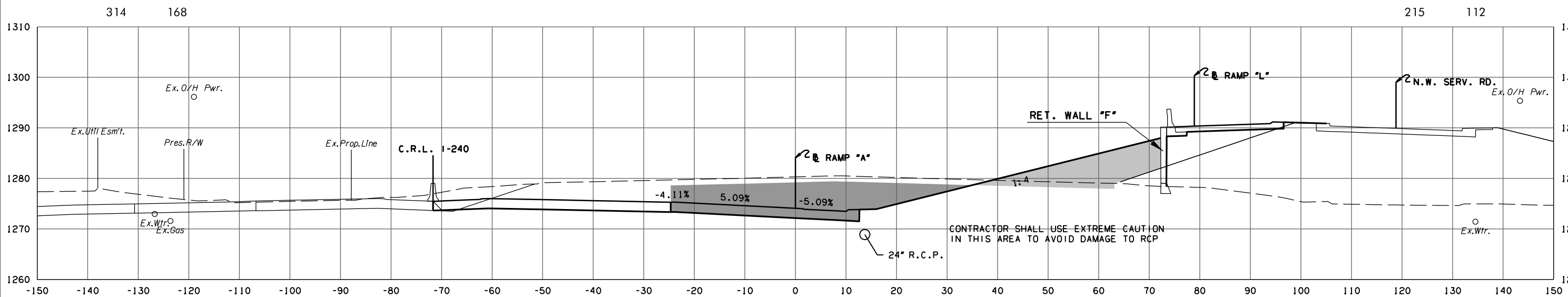

F.G. ELEV. = 1274.09
108 + 00.00

RAMP A PHASE 4

STATE JOB NO. 09032(08)
OKLAHOMA COUNTY SHEET NO. X135

3/4/2024 3:57:24 PM H:\PROJECTS\2789_CrossRoads_Phase 4\Roadway\Drawings\Sections\0903208-XSEC_Ramp_A.dgn

(CAUTION) THE LOCATION OF ALL UTILITIES AS SHOWN ARE APPROXIMATE. DUE TO RELOCATION'S PLANNED OR PRESENTLY UNDER CONSTRUCTION THERE ARE SOME UTILITIES THAT WILL BE RELOCATED AND NOT SHOWN ON THESE PLANS. THE CONTRACTOR SHALL BE RESPONSIBLE FOR ANY DAMAGE TO ALL UTILITIES.

SEE DRAINAGE AREA MAP SHEETS FOR DRAINAGE SYMBOLOLOGY.

R/W & U/E PURCHASED UNDER JP 09032(05)

POB & ASSOCIATES, OKLAHOMA CITY, OK.
90% PLAN SUBMITTAL
 3/4/2024

DEPTH & LOCATION OF EXISTING UTILITIES SHALL BE FIELD VERIFIED BY THE CONTRACTOR PRIOR TO CONSTRUCTION.

AREA
 CUT FILL

VOLUME
 CUT FILL

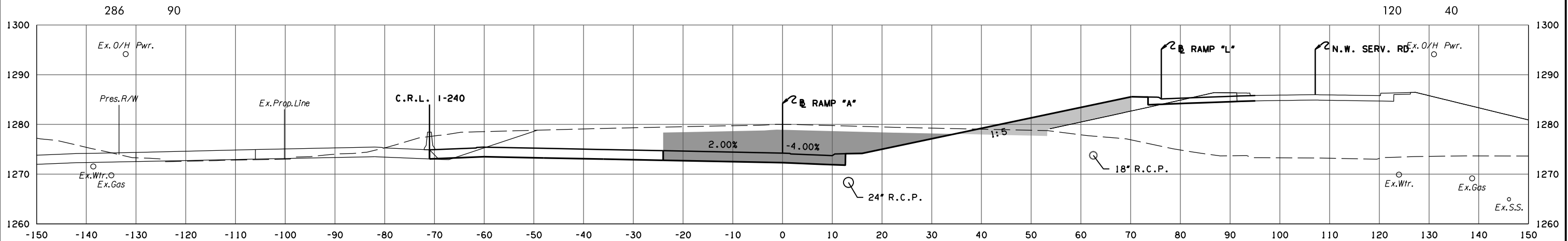

F.G. ELEV. = 1274.24
 109 + 11.31
 REVERSE CROWN

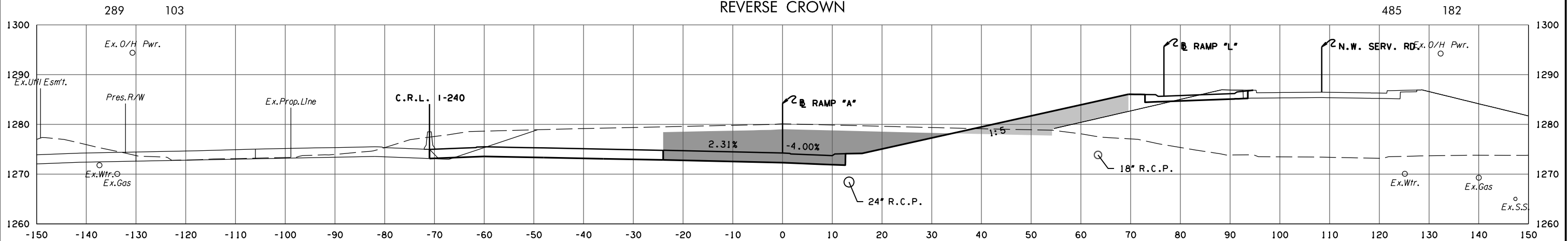

F.G. ELEV. = 1274.23
 109 + 00.00

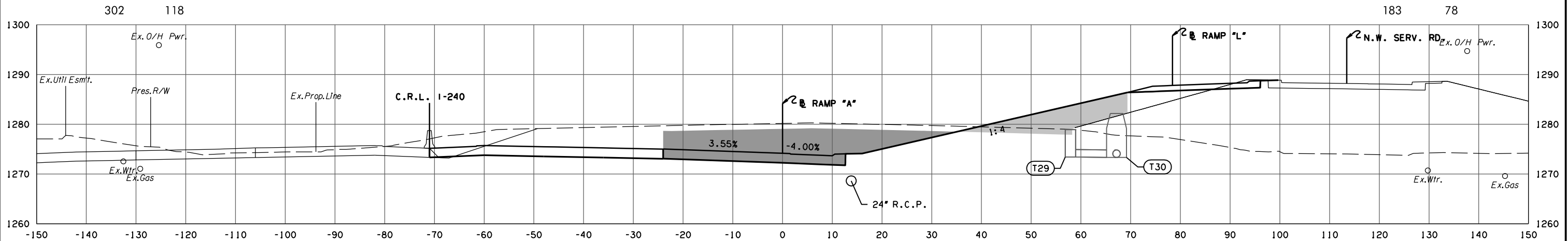

F.G. ELEV. = 1274.18
 108 + 55.65

STATE JOB NO. 09032(08)
 OKLAHOMA COUNTY SHEET NO. X136

3/4/2024 3:57:25 PM H:\PROJECTS\2789_CrossRoads_Phase 4\Roadway\Drawings\Sections\0903208-XSEC_Ramp_A.dgn

(CAUTION) THE LOCATION OF ALL UTILITIES AS SHOWN ARE APPROXIMATE. DUE TO RELOCATION'S PLANNED OR PRESENTLY UNDER CONSTRUCTION THERE ARE SOME UTILITIES THAT WILL BE RELOCATED AND NOT SHOWN ON THESE PLANS. THE CONTRACTOR SHALL BE RESPONSIBLE FOR ANY DAMAGE TO ALL UTILITIES.

DEPTH & LOCATION OF EXISTING UTILITIES SHALL BE FIELD VERIFIED BY THE CONTRACTOR PRIOR TO CONSTRUCTION.

SEE DRAINAGE AREA MAP SHEETS FOR DRAINAGE SYMBOLOLOGY.

R/W & U/E PURCHASED UNDER JP 09032(05)

POB & ASSOCIATES, OKLAHOMA CITY, OK.

**90% PLAN
SUBMITTAL**

3/4/2024

AREA
CUT FILL

VOLUME
CUT FILL

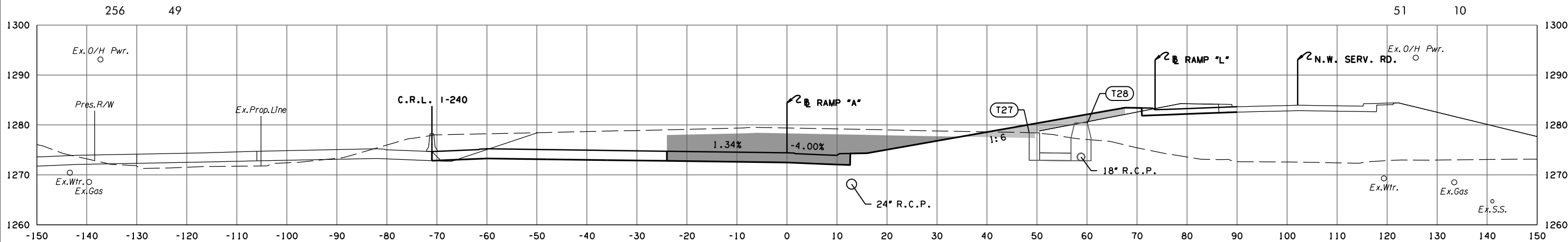

F.G. ELEV. = 1274.42
109 + 55.34

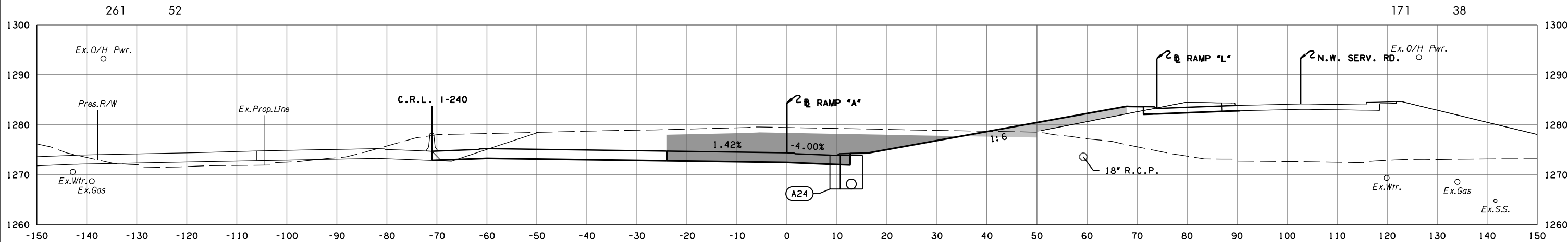

F.G. ELEV. = 1274.40
109 + 50.00

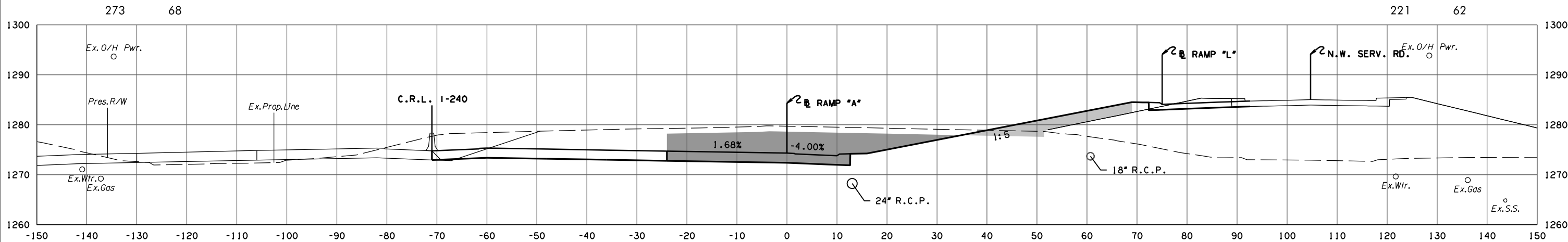

F.G. ELEV. = 1274.33
109 + 32.67

RAMP A PHASE 4

STATE JOB NO. 09032(08)
OKLAHOMA COUNTY SHEET NO. X137

3/4/2024 3:57:26 PM H:\PROJECTS\2789_CrossRoads_Phase 4\Roadway\Drawings\Sections\0903208-XSEC_Ramp_A.dgn

(CAUTION) THE LOCATION OF ALL UTILITIES AS SHOWN ARE APPROXIMATE. DUE TO RELOCATION'S PLANNED OR PRESENTLY UNDER CONSTRUCTION THERE ARE SOME UTILITIES THAT WILL BE RELOCATED AND NOT SHOWN ON THESE PLANS. THE CONTRACTOR SHALL BE RESPONSIBLE FOR ANY DAMAGE TO ALL UTILITIES.
 DEPTH & LOCATION OF EXISTING UTILITIES SHALL BE FIELD VERIFIED BY THE CONTRACTOR PRIOR TO CONSTRUCTION.

SEE DRAINAGE AREA MAP SHEETS FOR DRAINAGE SYMBOLOLOGY.

R/W & U/E PURCHASED UNDER JP 09032(05)

POB & ASSOCIATES, OKLAHOMA CITY, OK.
90% PLAN SUBMITTAL
 3/4/2024

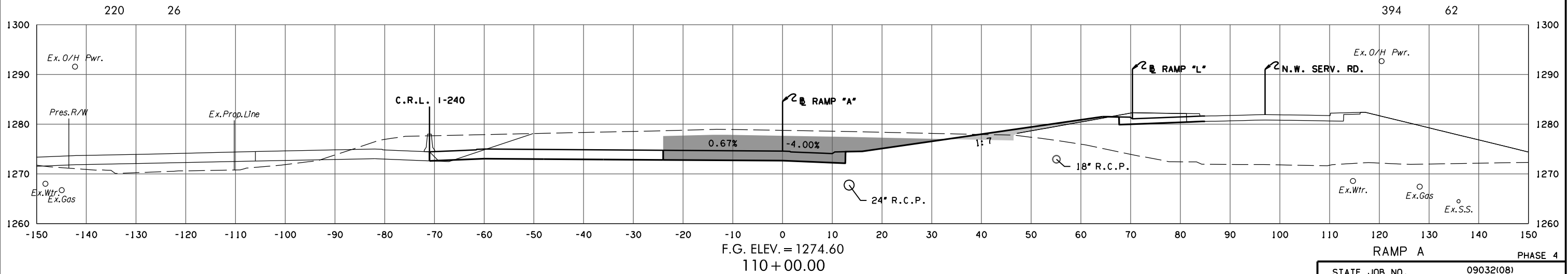
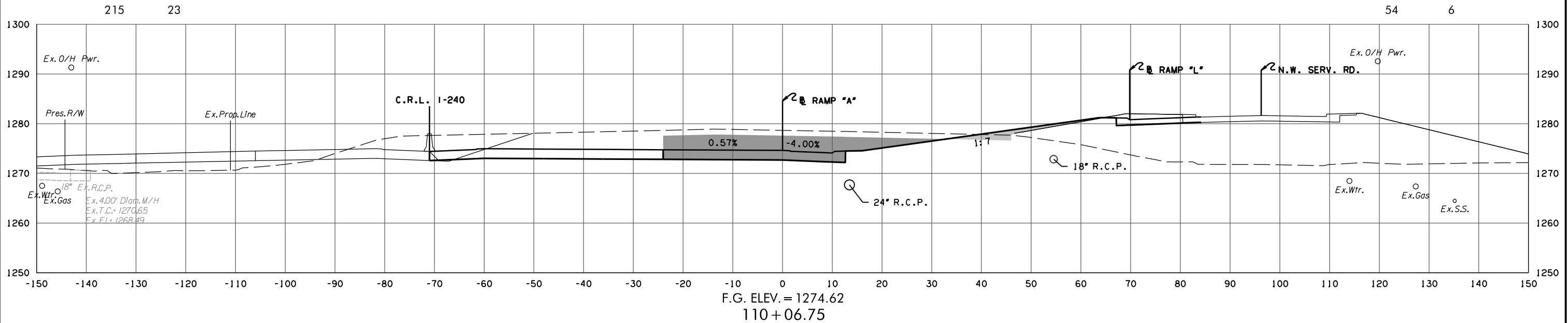
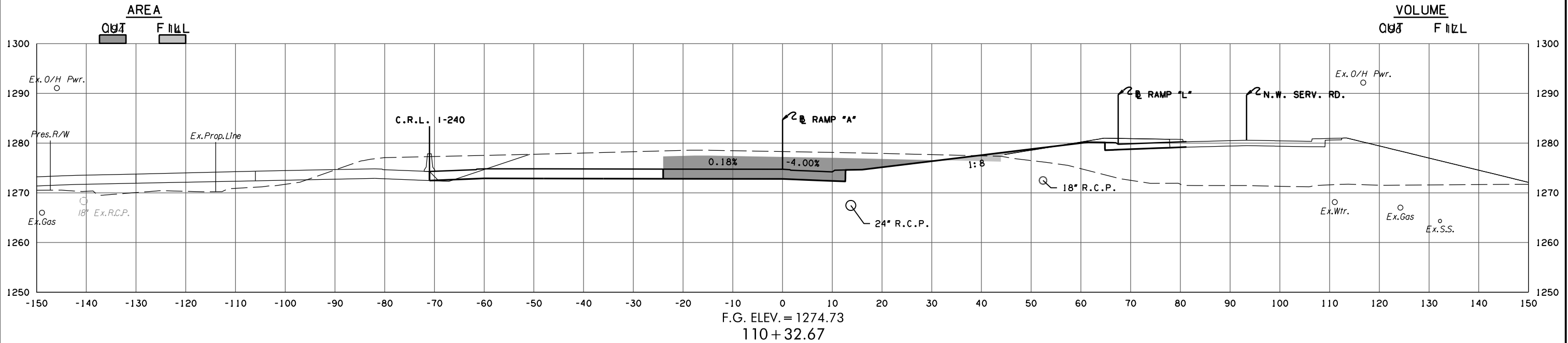

3/4/2024 3:57:27 PM H:\PROJECTS\2789_CrossRoads_Phase 4\Roadway\Drawings\Sections\0903208-XSEC-Ramp-A.dgn

(CAUTION) THE LOCATION OF ALL UTILITIES AS SHOWN ARE APPROXIMATE. DUE TO RELOCATION'S PLANNED OR PRESENTLY UNDER CONSTRUCTION THERE ARE SOME UTILITIES THAT WILL BE RELOCATED AND NOT SHOWN ON THESE PLANS. THE CONTRACTOR SHALL BE RESPONSIBLE FOR ANY DAMAGE TO ALL UTILITIES.

DEPTH & LOCATION OF EXISTING UTILITIES SHALL BE FIELD VERIFIED BY THE CONTRACTOR PRIOR TO CONSTRUCTION.

SEE DRAINAGE AREA MAP SHEETS FOR DRAINAGE SYMBOLOLOGY.

R/W & U/E PURCHASED UNDER JP 09032(05)

POB & ASSOCIATES, OKLAHOMA CITY, OK.

**90% PLAN
SUBMITTAL**

3/4/2024

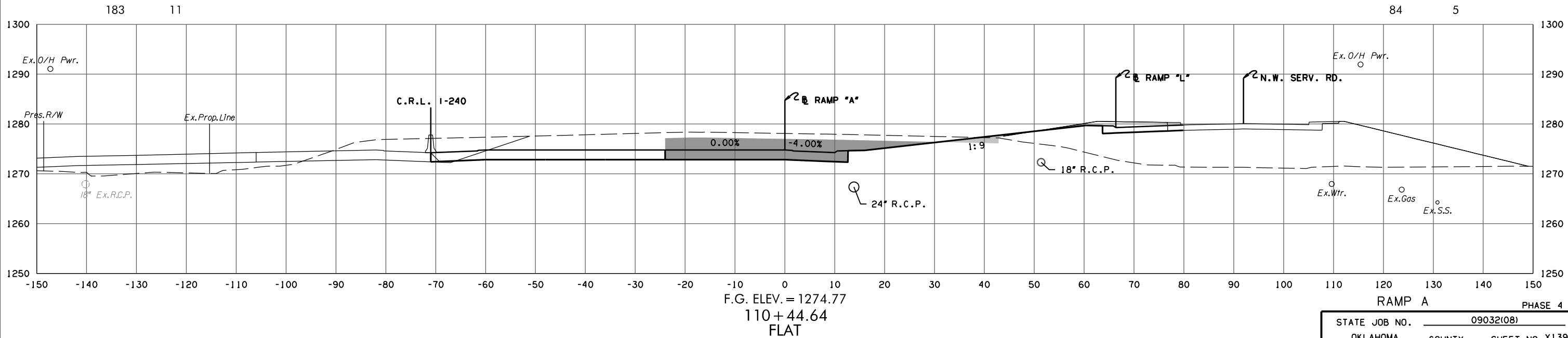
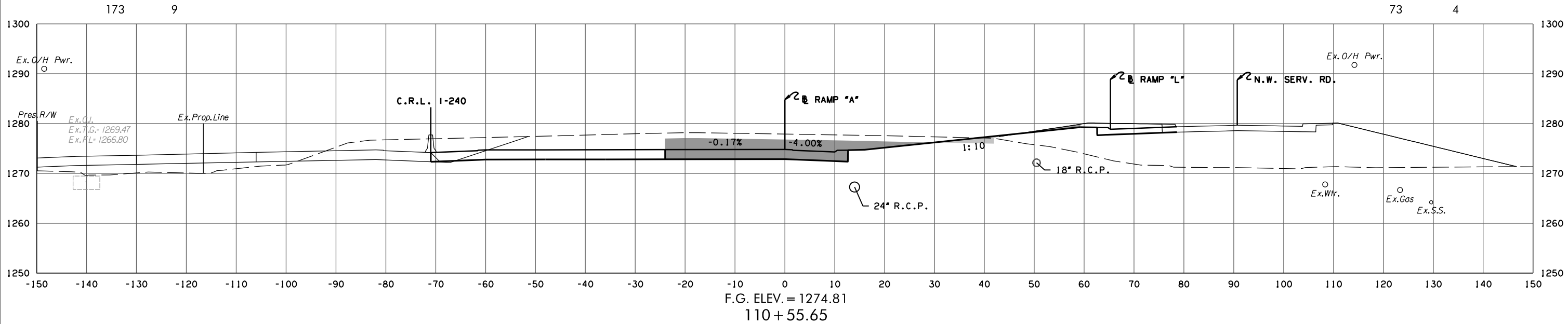
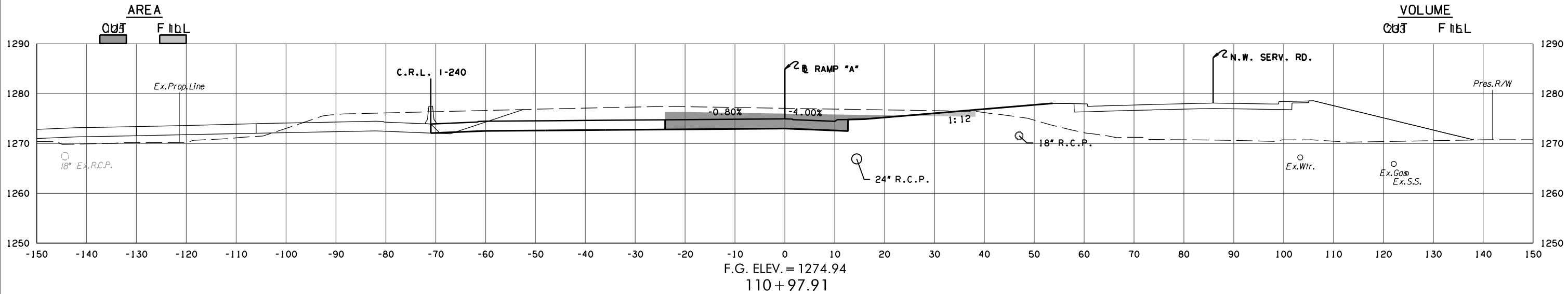

3/4/2024 3:57:27 PM H:\PROJECTS\2789_CrossRoads_Phase 4\Roadway\Drawings\Sections\0903208-XSEC_Ramp_A.dgn

(CAUTION) THE LOCATION OF ALL UTILITIES AS SHOWN ARE APPROXIMATE. DUE TO RELOCATION'S PLANNED OR PRESENTLY UNDER CONSTRUCTION THERE ARE SOME UTILITIES THAT WILL BE RELOCATED AND NOT SHOWN ON THESE PLANS. THE CONTRACTOR SHALL BE RESPONSIBLE FOR ANY DAMAGE TO ALL UTILITIES.

SEE DRAINAGE AREA MAP SHEETS FOR DRAINAGE SYMBOLOLOGY.

R/W & U/E PURCHASED UNDER JP 09032(05)

POB & ASSOCIATES, OKLAHOMA CITY, OK.

90% PLAN
SUBMITTAL

3/4/2024

DEPTH & LOCATION OF EXISTING UTILITIES SHALL BE FIELD VERIFIED BY THE CONTRACTOR PRIOR TO CONSTRUCTION.

AREA
CUT FILL

VOLUME
CUT FILL

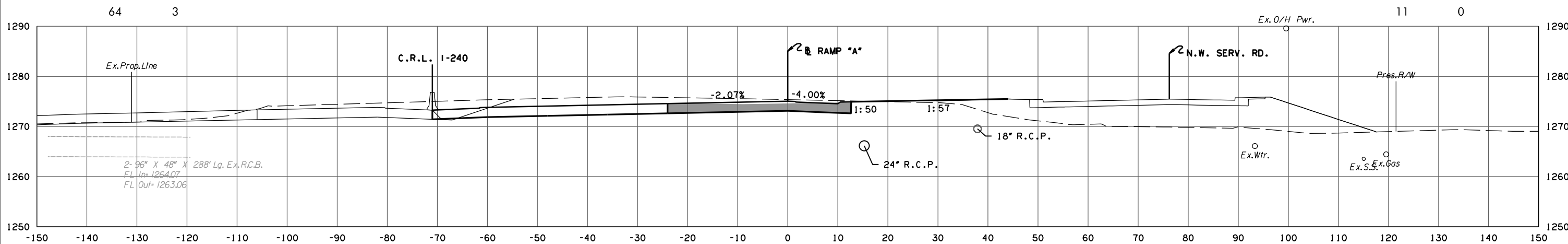

F.G. ELEV. = 1275.05
111+82.67

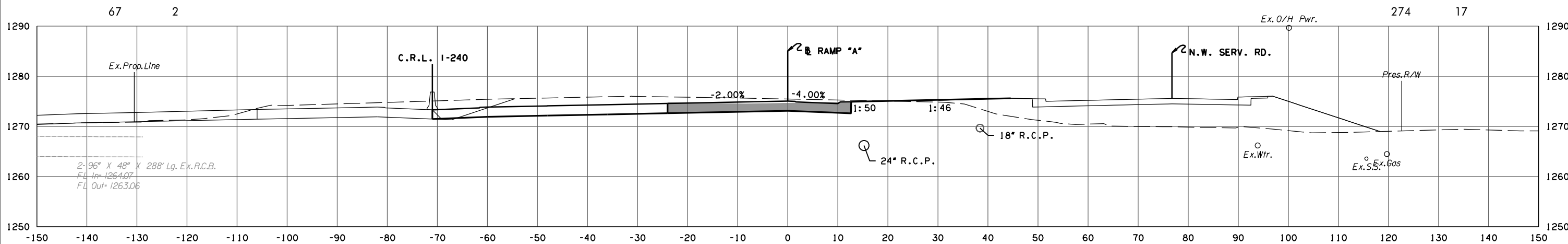

F.G. ELEV. = 1275.05
111+77.97
CONTINUOUS ROTATION

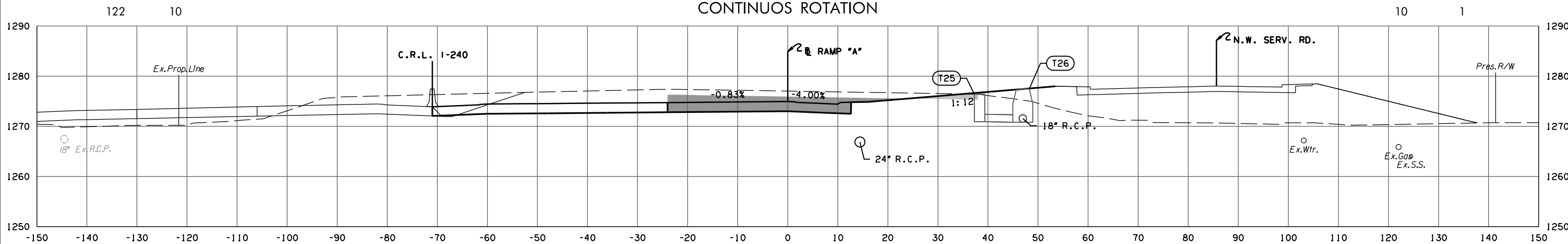

F.G. ELEV. = 1274.94
111+00.00

RAMP A PHASE 4

STATE JOB NO. 09032(08)
OKLAHOMA COUNTY SHEET NO. X140

3/4/2024 3:57:28 PM
H:\PROJECTS\2789_CrossRoads_Phase 4\Roadway\Drawings\Sections\0903208-XSEC-Ramp_A.dgn

(CAUTION) THE LOCATION OF ALL UTILITIES AS SHOWN ARE APPROXIMATE. DUE TO RELOCATION'S PLANNED OR PRESENTLY UNDER CONSTRUCTION THERE ARE SOME UTILITIES THAT WILL BE RELOCATED AND NOT SHOWN ON THESE PLANS. THE CONTRACTOR SHALL BE RESPONSIBLE FOR ANY DAMAGE TO ALL UTILITIES.
 DEPTH & LOCATION OF EXISTING UTILITIES SHALL BE FIELD VERIFIED BY THE CONTRACTOR PRIOR TO CONSTRUCTION.

SEE DRAINAGE AREA MAP SHEETS FOR DRAINAGE SYMBOLOLOGY.

R/W & U/E PURCHASED UNDER JP 09032(05)

POB & ASSOCIATES, OKLAHOMA CITY, OK.

90% PLAN SUBMITTAL

3/4/2024

AREA
 CUT FILL

VOLUME
 CUT FILL

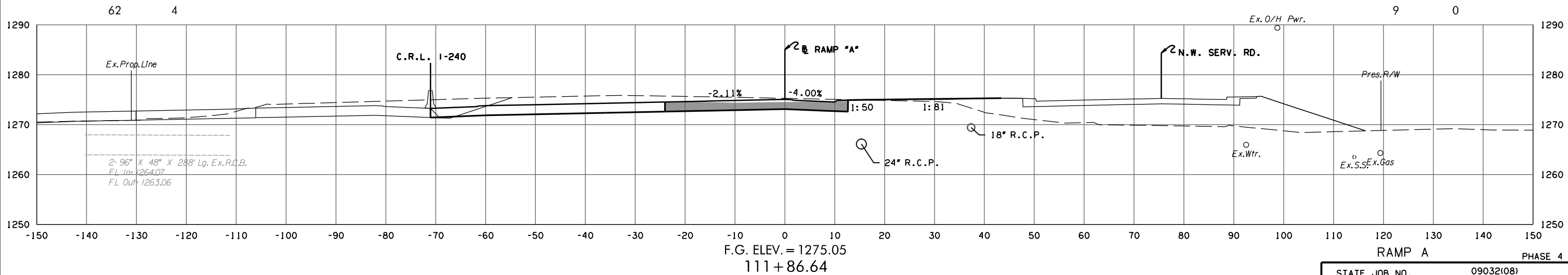
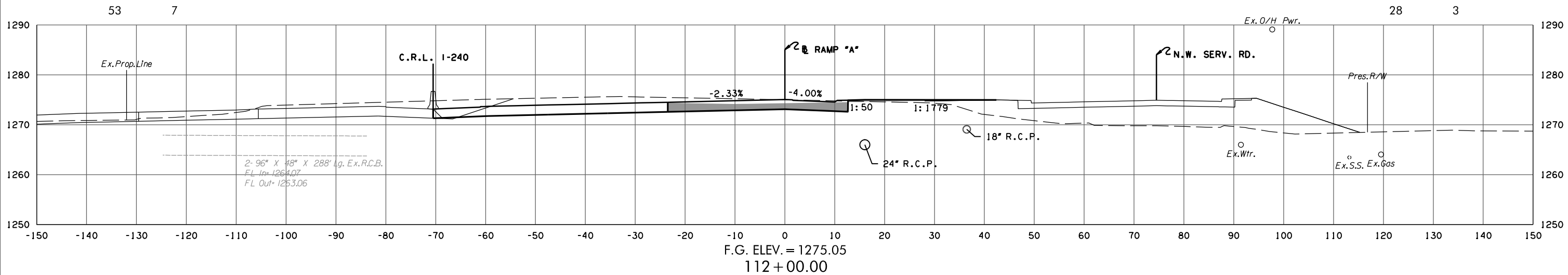
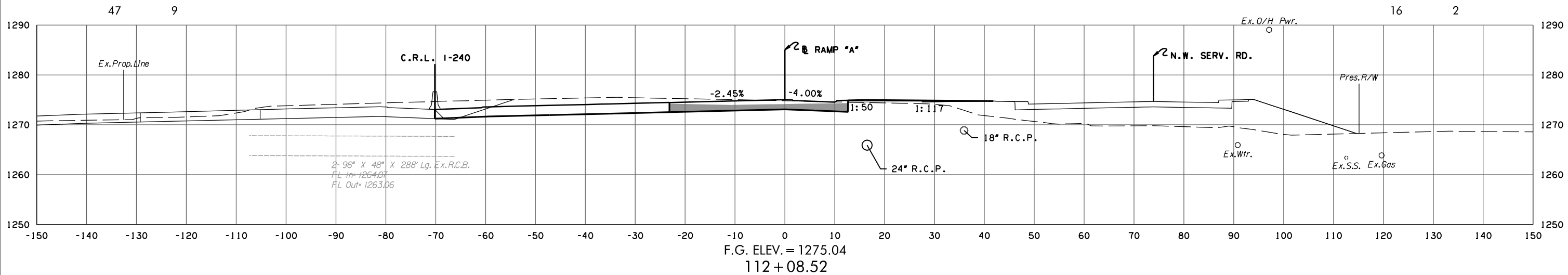

3/4/2024 3:57:29 PM H:\PROJECTS\2789_CrossRoads_Phase 4\Roadway\Drawings\Sections\0903208-XSEC_Ramp_A.dgn

(CAUTION) THE LOCATION OF ALL UTILITIES AS SHOWN ARE APPROXIMATE. DUE TO RELOCATION'S PLANNED OR PRESENTLY UNDER CONSTRUCTION THERE ARE SOME UTILITIES THAT WILL BE RELOCATED AND NOT SHOWN ON THESE PLANS. THE CONTRACTOR SHALL BE RESPONSIBLE FOR ANY DAMAGE TO ALL UTILITIES.

SEE DRAINAGE AREA MAP SHEETS FOR DRAINAGE SYMBOLOLOGY.

R/W & U/E PURCHASED UNDER JP 09032(05)

POB & ASSOCIATES, OKLAHOMA CITY, OK.

**90% PLAN
SUBMITTAL**

3/4/2024

AREA
CUT FILL

VOLUME
CUT FILL

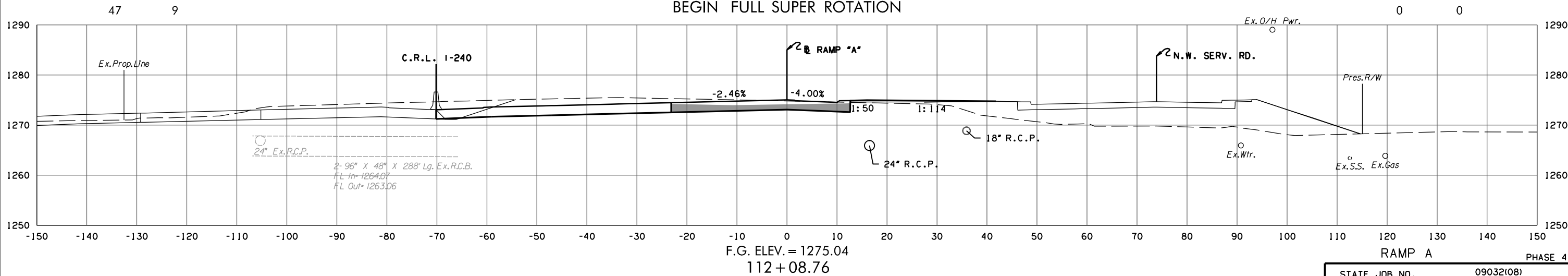
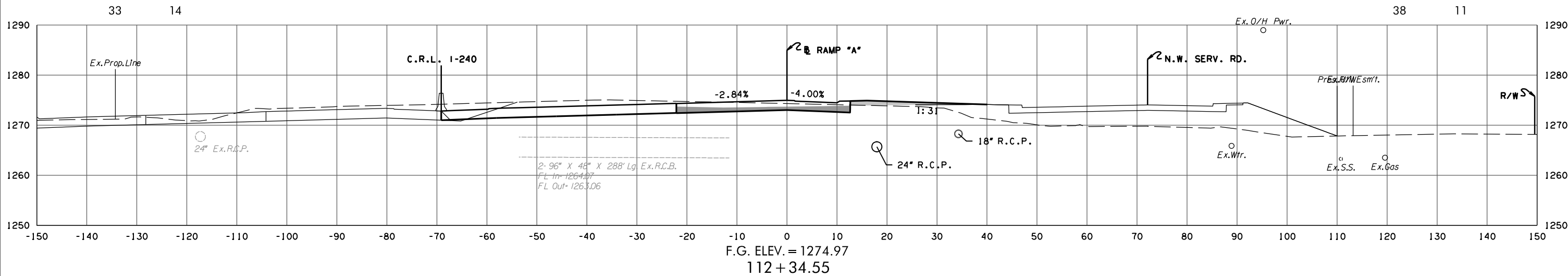
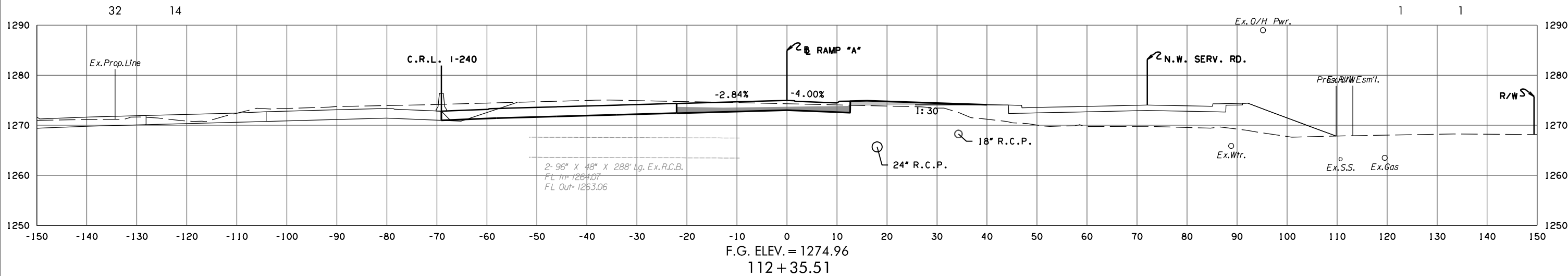

3/4/2024 3:57:30 PM H:\PROJECTS\2789_CrossRoads_Phase 4\Roadway\Drawings\Sections\0903208-XSEC_Ramp_A.dgn

(CAUTION) THE LOCATION OF ALL UTILITIES AS SHOWN ARE APPROXIMATE. DUE TO RELOCATION'S PLANNED OR PRESENTLY UNDER CONSTRUCTION THERE ARE SOME UTILITIES THAT WILL BE RELOCATED AND NOT SHOWN ON THESE PLANS. THE CONTRACTOR SHALL BE RESPONSIBLE FOR ANY DAMAGE TO ALL UTILITIES.
 DEPTH & LOCATION OF EXISTING UTILITIES SHALL BE FIELD VERIFIED BY THE CONTRACTOR PRIOR TO CONSTRUCTION.

SEE DRAINAGE AREA MAP SHEETS FOR DRAINAGE SYMBOLOLOGY.

R/W & U/E PURCHASED UNDER JP 09032(05)

POB & ASSOCIATES, OKLAHOMA CITY, OK.
90% PLAN SUBMITTAL
 3/4/2024

AREA
 CUT FILL

VOLUME
 CUT FILL

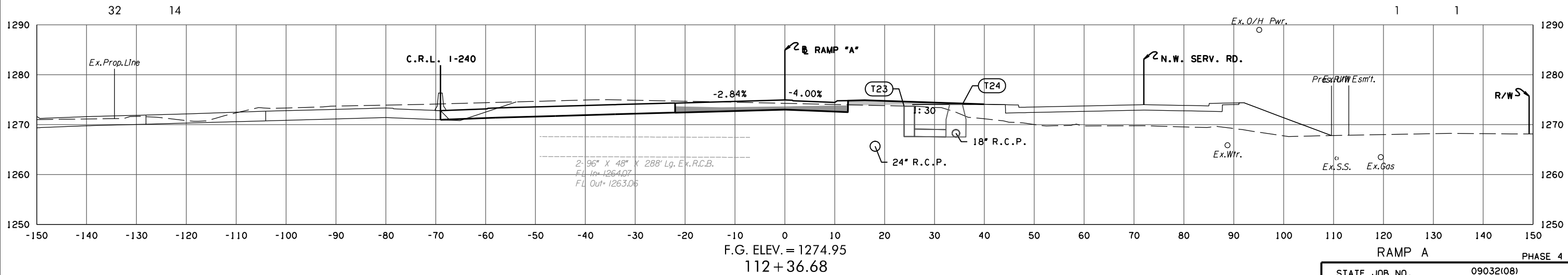
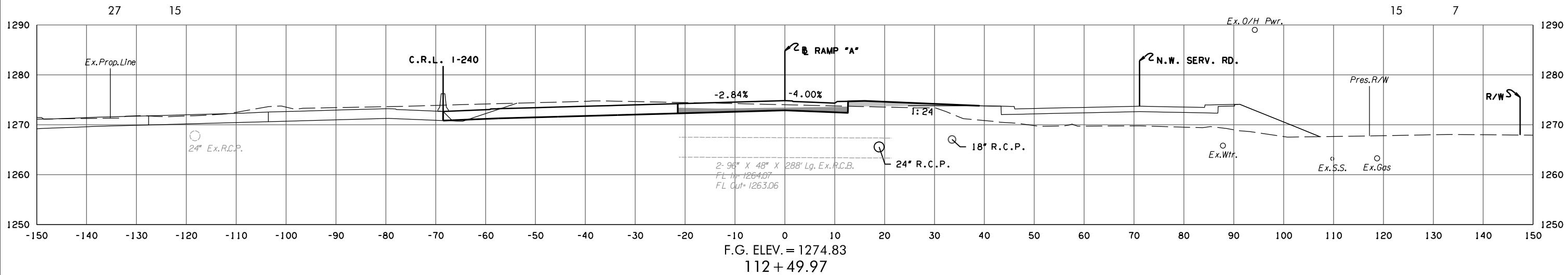
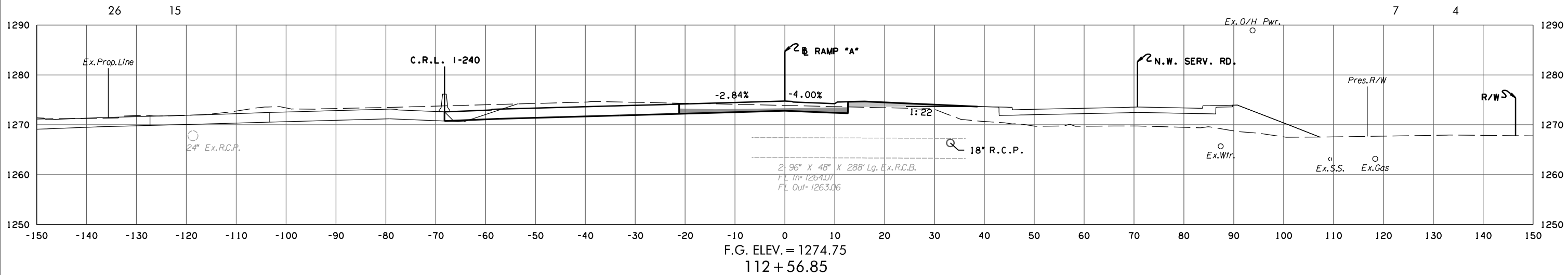

3/4/2024 3:57:38 PM
 H:\PROJECTS\2789_CrossRoads_Phase 4\Roadway\Drawings\Sections\0903208-XSEC_Ramp_A.dgn

STATE JOB NO. 09032(08)
 OKLAHOMA COUNTY SHEET NO. X143

(CAUTION) THE LOCATION OF ALL UTILITIES AS SHOWN ARE APPROXIMATE. DUE TO RELOCATION'S PLANNED OR PRESENTLY UNDER CONSTRUCTION THERE ARE SOME UTILITIES THAT WILL BE RELOCATED AND NOT SHOWN ON THESE PLANS. THE CONTRACTOR SHALL BE RESPONSIBLE FOR ANY DAMAGE TO ALL UTILITIES.

SEE DRAINAGE AREA MAP SHEETS FOR DRAINAGE SYMBOLOLOGY.

R/W & U/E PURCHASED UNDER JP 09032(05)

POE & ASSOCIATES, OKLAHOMA CITY, OK.

**90% PLAN
SUBMITTAL**

3/4/2024

DEPTH & LOCATION OF EXISTING UTILITIES SHALL BE FIELD VERIFIED BY THE CONTRACTOR PRIOR TO CONSTRUCTION.

AREA
CUT FILL

VOLUME
CUT FILL

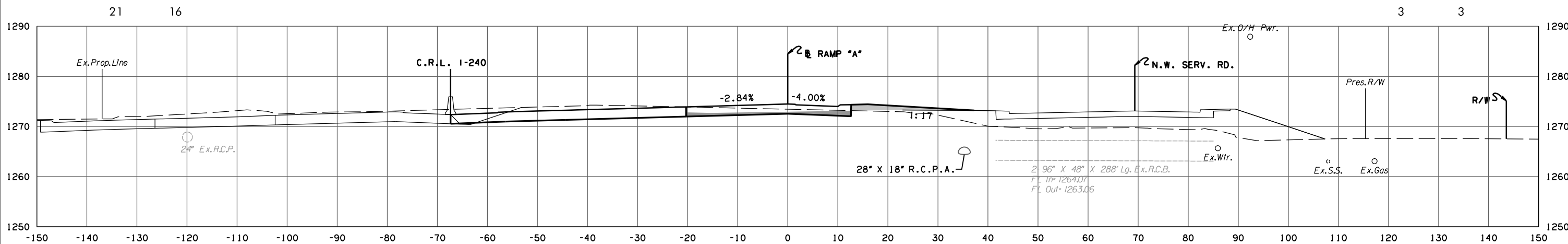

F.G. ELEV. = 1274.49
112+79.30

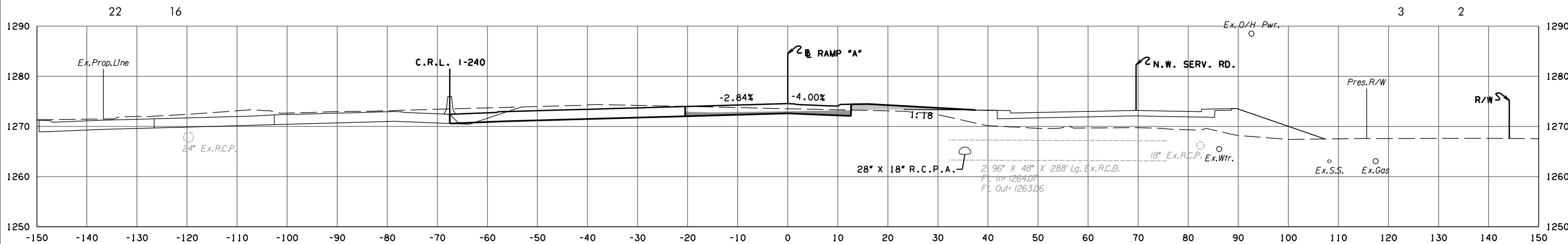

F.G. ELEV. = 1274.54
112+74.98

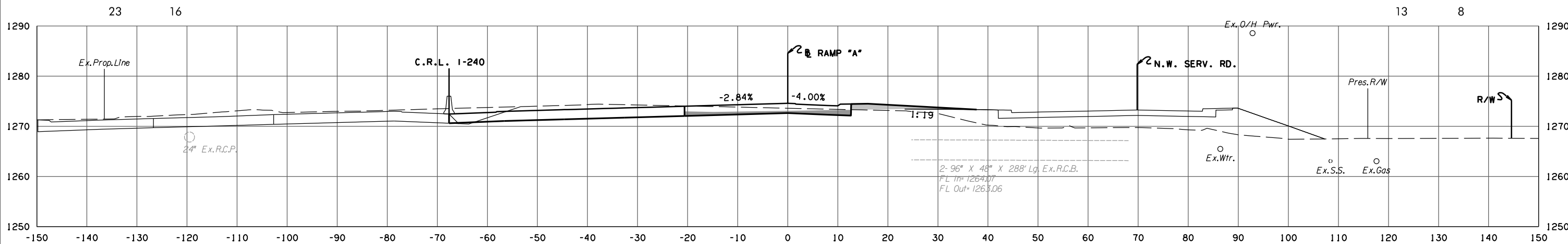

F.G. ELEV. = 1274.58
112+71.50

RAMP A PHASE 4

STATE JOB NO. 09032(08)
OKLAHOMA COUNTY SHEET NO. X144

3/4/2024 3:57:39 PM H:\PROJECTS\2789_CrossRoads_Phase 4\Roadway\Drawings\Sections\0903208-XSEC_Ramp_A.dgn

(CAUTION) THE LOCATION OF ALL UTILITIES AS SHOWN ARE APPROXIMATE. DUE TO RELOCATION'S PLANNED OR PRESENTLY UNDER CONSTRUCTION THERE ARE SOME UTILITIES THAT WILL BE RELOCATED AND NOT SHOWN ON THESE PLANS. THE CONTRACTOR SHALL BE RESPONSIBLE FOR ANY DAMAGE TO ALL UTILITIES.
 DEPTH & LOCATION OF EXISTING UTILITIES SHALL BE FIELD VERIFIED BY THE CONTRACTOR PRIOR TO CONSTRUCTION.

SEE DRAINAGE AREA MAP SHEETS FOR DRAINAGE SYMBOLOLOGY.

R/W & U/E PURCHASED UNDER JP 09032(05)

POB & ASSOCIATES, OKLAHOMA CITY, OK.
90% PLAN SUBMITTAL
 3/4/2024

AREA
 CUT FILL

VOLUME
 CUT FILL

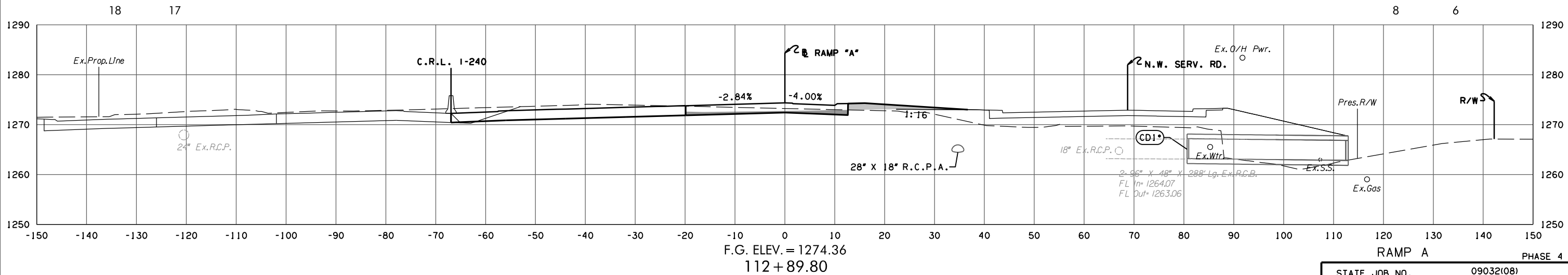
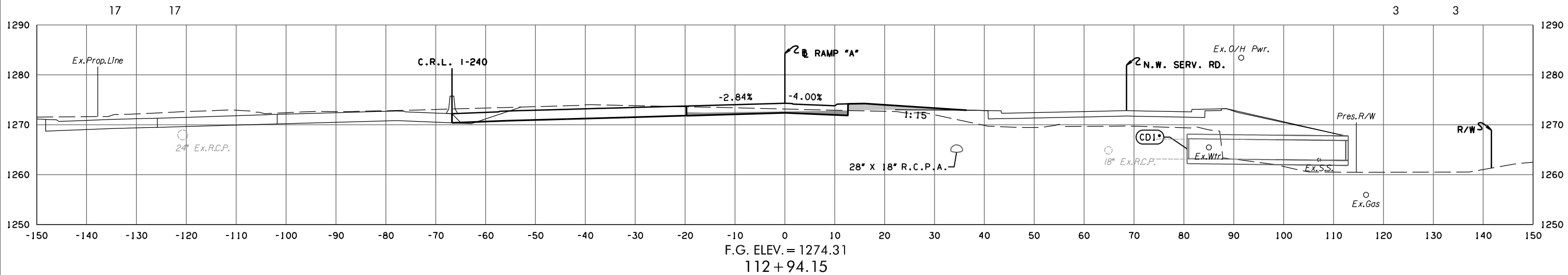
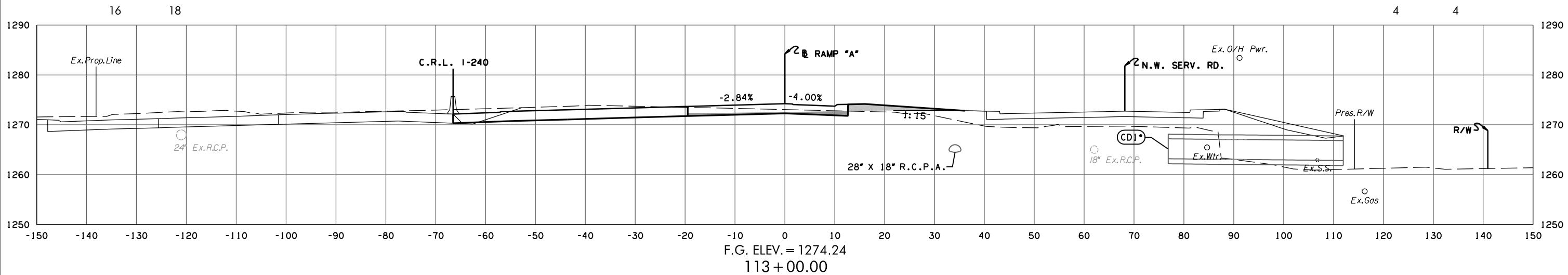

3/4/2024 3:57:39 PM H:\PROJECTS\2785_CrossRoads_Phase 4\Roadway\Drawings\Sections\0903208-XSEC_Ramp_A.dgn

STATE JOB NO. 09032(08)
 OKLAHOMA COUNTY SHEET NO. X145

(CAUTION) THE LOCATION OF ALL UTILITIES AS SHOWN ARE APPROXIMATE. DUE TO RELOCATION'S PLANNED OR PRESENTLY UNDER CONSTRUCTION THERE ARE SOME UTILITIES THAT WILL BE RELOCATED AND NOT SHOWN ON THESE PLANS. THE CONTRACTOR SHALL BE RESPONSIBLE FOR ANY DAMAGE TO ALL UTILITIES.
 DEPTH & LOCATION OF EXISTING UTILITIES SHALL BE FIELD VERIFIED BY THE CONTRACTOR PRIOR TO CONSTRUCTION.

SEE DRAINAGE AREA MAP SHEETS FOR DRAINAGE SYMBOLOLOGY.

R/W & U/E PURCHASED UNDER JP 09032(05)

POB & ASSOCIATES, OKLAHOMA CITY, OK.
90% PLAN SUBMITTAL
 3/4/2024

AREA
 CUT FILL

VOLUME
 CUT FILL

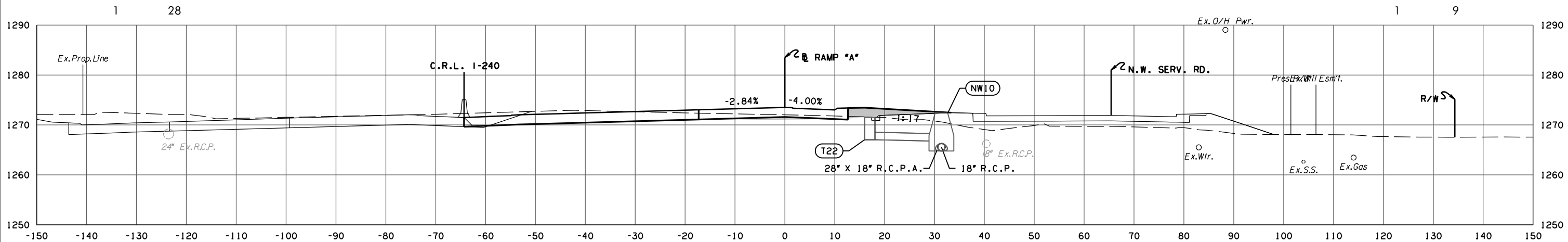

F.G. ELEV. = 1273.52
 113 + 55.13

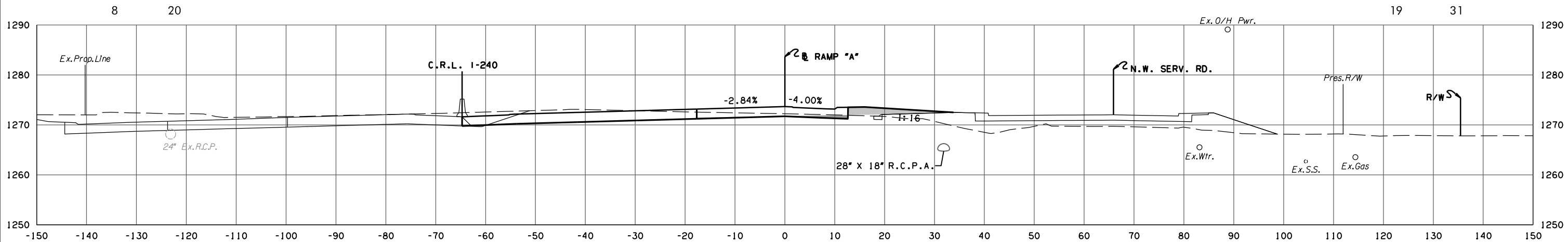

F.G. ELEV. = 1273.66
 113 + 45.30

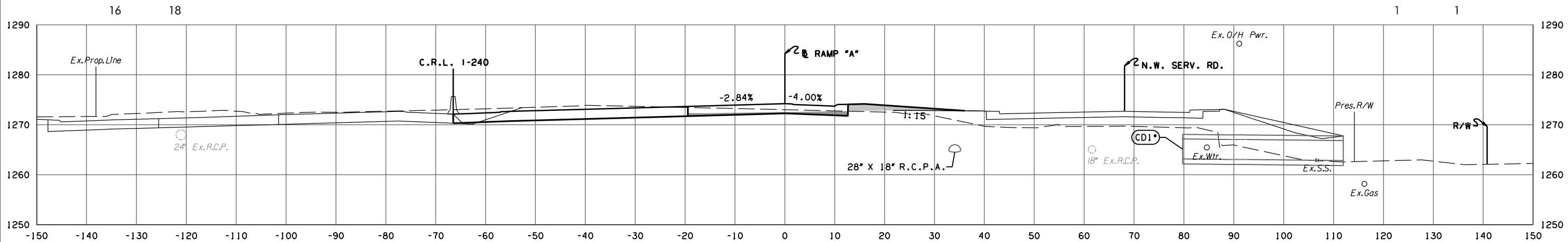

F.G. ELEV. = 1274.23
 113 + 01.00

STATE JOB NO. 09032(08)
 OKLAHOMA COUNTY SHEET NO. X146

3/4/2024 3:57:40 PM
 H:\PROJECTS\2789_Crossroads_Phase 4\Roadway\Drawings\Sections\0903208-XSEC_Ramp_A.dgn

(CAUTION) THE LOCATION OF ALL UTILITIES AS SHOWN ARE APPROXIMATE. DUE TO RELOCATION'S PLANNED OR PRESENTLY UNDER CONSTRUCTION THERE ARE SOME UTILITIES THAT WILL BE RELOCATED AND NOT SHOWN ON THESE PLANS. THE CONTRACTOR SHALL BE RESPONSIBLE FOR ANY DAMAGE TO ALL UTILITIES.

DEPTH & LOCATION OF EXISTING UTILITIES SHALL BE FIELD VERIFIED BY THE CONTRACTOR PRIOR TO CONSTRUCTION.

SEE DRAINAGE AREA MAP SHEETS FOR DRAINAGE SYMBOLOLOGY.

R/W & U/E PURCHASED UNDER JP 09032(05)

POB & ASSOCIATES, OKLAHOMA CITY, OK.

**90% PLAN
SUBMITTAL**

3/4/2024

AREA
CUT FILL

VOLUME
CUT FILL

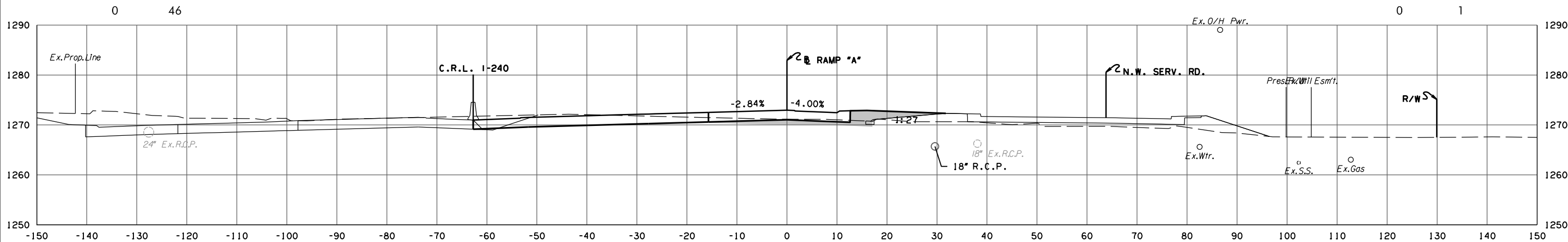

F.G. ELEV. = 1272.97
113+94.39

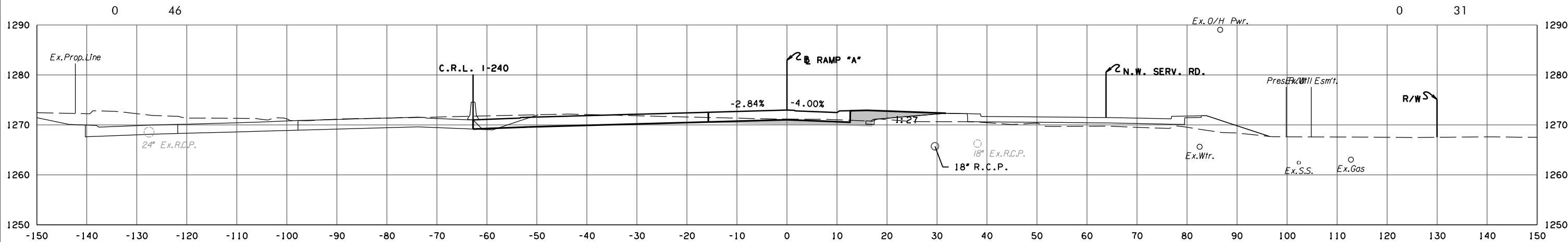

F.G. ELEV. = 1272.97
113+94.00

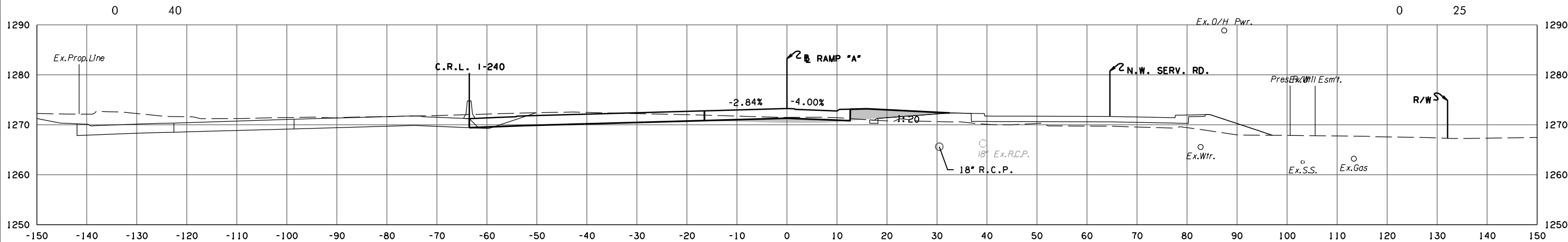

F.G. ELEV. = 1273.25
113+74.70

RAMP A PHASE 4

STATE JOB NO. 09032(08)
OKLAHOMA COUNTY SHEET NO. X147

3/4/2024 3:57:41 PM H:\PROJECTS\2789_CrossRoads_Phase 4\Roadway\Drawings\Sections\0903208-XSEC_Ramp_A.dgn

(CAUTION) THE LOCATION OF ALL UTILITIES AS SHOWN ARE APPROXIMATE. DUE TO RELOCATION'S PLANNED OR PRESENTLY UNDER CONSTRUCTION THERE ARE SOME UTILITIES THAT WILL BE RELOCATED AND NOT SHOWN ON THESE PLANS. THE CONTRACTOR SHALL BE RESPONSIBLE FOR ANY DAMAGE TO ALL UTILITIES.

DEPTH & LOCATION OF EXISTING UTILITIES SHALL BE FIELD VERIFIED BY THE CONTRACTOR PRIOR TO CONSTRUCTION.

SEE DRAINAGE AREA MAP SHEETS FOR DRAINAGE SYMBOLOLOGY.

R/W & U/E PURCHASED UNDER JP 09032(05)

POB & ASSOCIATES, OKLAHOMA CITY, OK.

**90% PLAN
SUBMITTAL**

3/4/2024

AREA
CUT FILL

VOLUME
CUT FILL

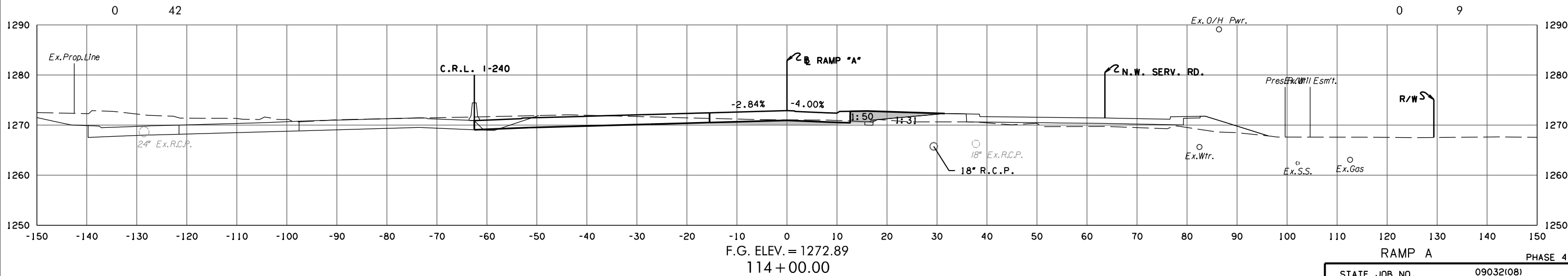
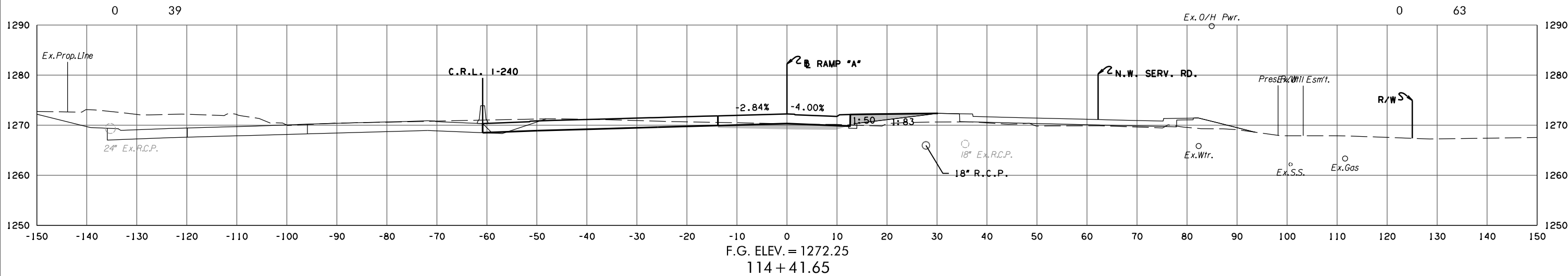
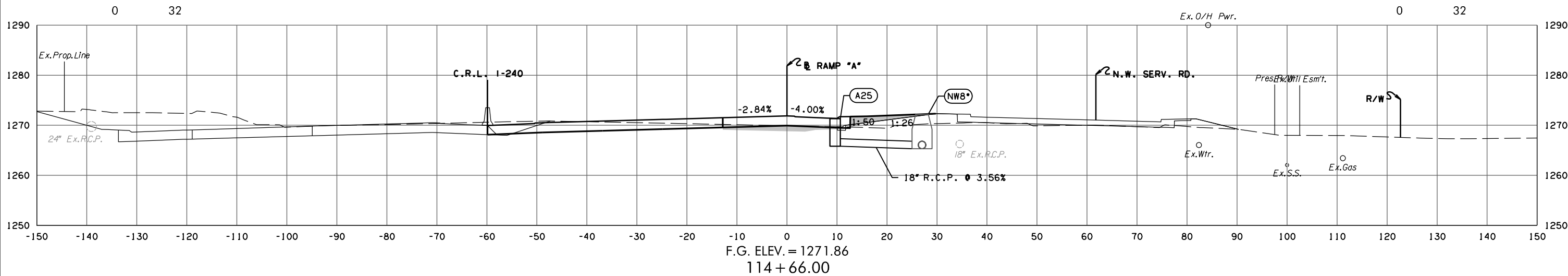

3/4/2024 3:57:42 PM H:\PROJECTS\2789_CrossRoads_Phase 4\Roadway\Drawings\Sections\0903208-XSEC_Ramp_A.dgn

(CAUTION) THE LOCATION OF ALL UTILITIES AS SHOWN ARE APPROXIMATE. DUE TO RELOCATION'S PLANNED OR PRESENTLY UNDER CONSTRUCTION THERE ARE SOME UTILITIES THAT WILL BE RELOCATED AND NOT SHOWN ON THESE PLANS. THE CONTRACTOR SHALL BE RESPONSIBLE FOR ANY DAMAGE TO ALL UTILITIES.
 DEPTH & LOCATION OF EXISTING UTILITIES SHALL BE FIELD VERIFIED BY THE CONTRACTOR PRIOR TO CONSTRUCTION.

SEE DRAINAGE AREA MAP SHEETS FOR DRAINAGE SYMBOLOLOGY.

R/W & U/E PURCHASED UNDER JP 09032(05)

POB & ASSOCIATES, OKLAHOMA CITY, OK.
90% PLAN
SUBMITTAL
 3/4/2024

AREA
 CUT FILL

VOLUME
 CUT FILL

3/4/2024 3:57:43 PM H:\PROJECTS\2789_CrossRoads_Phase 4\Roadway\Drawings\Sections\0903208-XSEC_Ramp_A.dgn

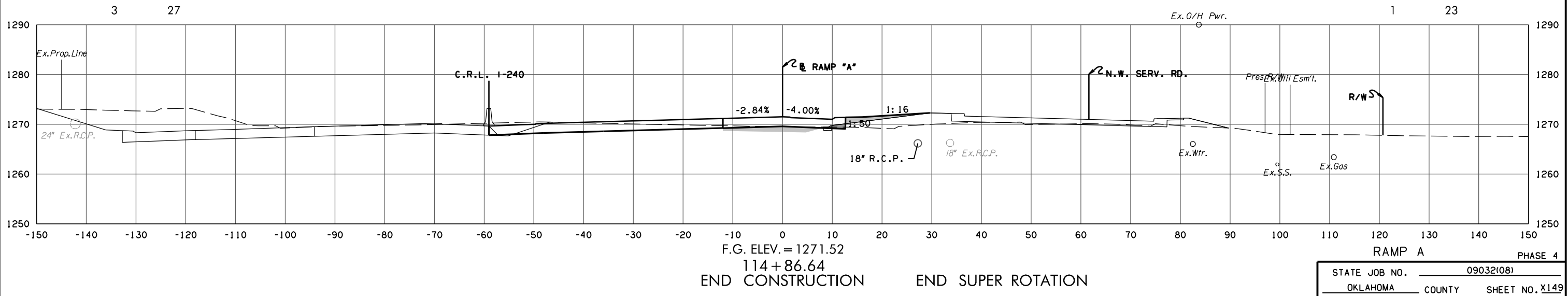

F.G. ELEV. = 1271.52
 114+86.64
 END CONSTRUCTION END SUPER ROTATION

STATE JOB NO. 09032(08)
 OKLAHOMA COUNTY SHEET NO. X149

(CAUTION) THE LOCATION OF ALL UTILITIES AS SHOWN ARE APPROXIMATE. DUE TO RELOCATION'S PLANNED OR PRESENTLY UNDER CONSTRUCTION THERE ARE SOME UTILITIES THAT WILL BE RELOCATED AND NOT SHOWN ON THESE PLANS. THE CONTRACTOR SHALL BE RESPONSIBLE FOR ANY DAMAGE TO ALL UTILITIES.
 DEPTH & LOCATION OF EXISTING UTILITIES SHALL BE FIELD VERIFIED BY THE CONTRACTOR PRIOR TO CONSTRUCTION.

SEE DRAINAGE AREA MAP SHEETS FOR DRAINAGE SYMBOLOLOGY.

R/W & U/E PURCHASED UNDER JP 09032(05)

POB & ASSOCIATES, OKLAHOMA CITY, OK.
90% PLAN SUBMITTAL
 3/4/2024

AREA
 CUT FILL

VOLUME
 CUT FILL

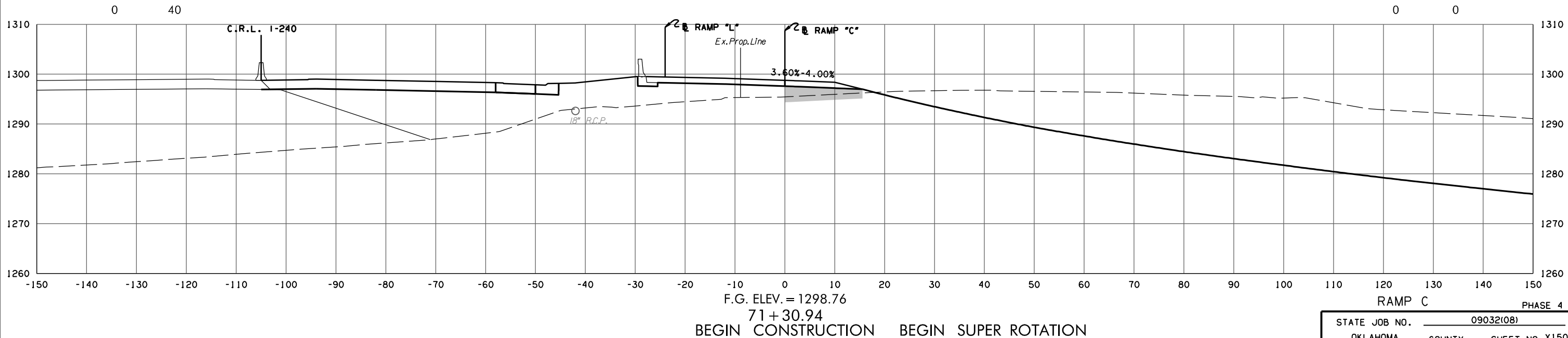
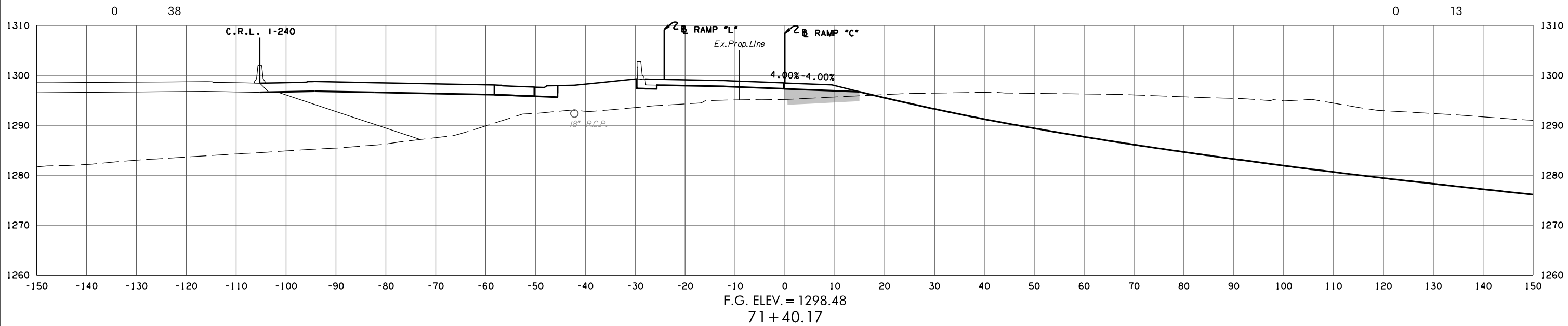

BEGIN CONSTRUCTION BEGIN SUPER ROTATION

STATE JOB NO. 09032(08)
 OKLAHOMA COUNTY SHEET NO. X150

3/4/2024 3:57:44 PM
 H:\PROJECTS\2789_CrossRoads_Phase 4\Roadway\Drawings\Sections\0903208-XSEC_Ramp_C.dgn

(CAUTION) THE LOCATION OF ALL UTILITIES AS SHOWN ARE APPROXIMATE. DUE TO RELOCATION'S PLANNED OR PRESENTLY UNDER CONSTRUCTION THERE ARE SOME UTILITIES THAT WILL BE RELOCATED AND NOT SHOWN ON THESE PLANS. THE CONTRACTOR SHALL BE RESPONSIBLE FOR ANY DAMAGE TO ALL UTILITIES.
 DEPTH & LOCATION OF EXISTING UTILITIES SHALL BE FIELD VERIFIED BY THE CONTRACTOR PRIOR TO CONSTRUCTION.

SEE DRAINAGE AREA MAP SHEETS FOR DRAINAGE SYMBOLOLOGY.

R/W & U/E PURCHASED UNDER JP 09032(05)

POB & ASSOCIATES, OKLAHOMA CITY, OK.

90% PLAN SUBMITTAL

3/4/2024

AREA
 CUT FILL

VOLUME
 CUT FILL

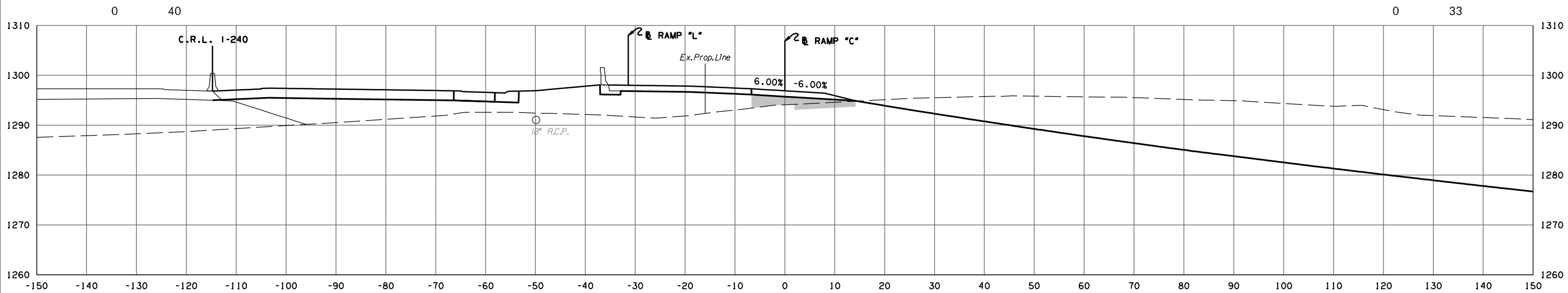

F.G. ELEV. = 1296.90

71+85.77

BEGIN FULL SUPER ROTATION

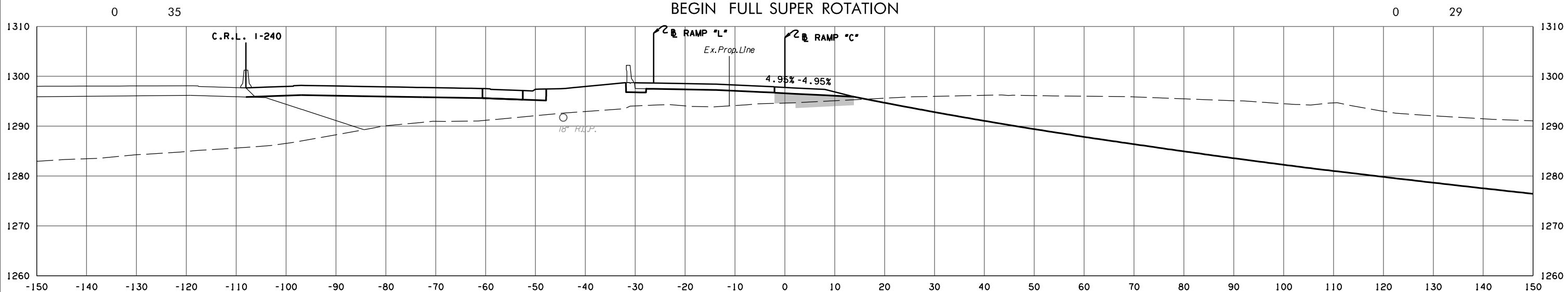

F.G. ELEV. = 1297.76

71+61.83

RAMP C PHASE 4

STATE JOB NO. 09032(08)
 OKLAHOMA COUNTY SHEET NO. X151

3/4/2024 3:57:45 PM H:\PROJECTS\2789_CrossRoads_Phase 4\Roadway\Drawings\Sections\0903208-XSEC_Ramp_C.dgn

(CAUTION) THE LOCATION OF ALL UTILITIES AS SHOWN ARE APPROXIMATE. DUE TO RELOCATION'S PLANNED OR PRESENTLY UNDER CONSTRUCTION THERE ARE SOME UTILITIES THAT WILL BE RELOCATED AND NOT SHOWN ON THESE PLANS. THE CONTRACTOR SHALL BE RESPONSIBLE FOR ANY DAMAGE TO ALL UTILITIES.
 DEPTH & LOCATION OF EXISTING UTILITIES SHALL BE FIELD VERIFIED BY THE CONTRACTOR PRIOR TO CONSTRUCTION.

SEE DRAINAGE AREA MAP SHEETS FOR DRAINAGE SYMBOLOLOGY.

R/W & U/E PURCHASED UNDER JP 09032(05)

POB & ASSOCIATES, OKLAHOMA CITY, OK.

**90% PLAN
SUBMITTAL**

3/4/2024

AREA
CUT FILL

VOLUME
CUT FILL

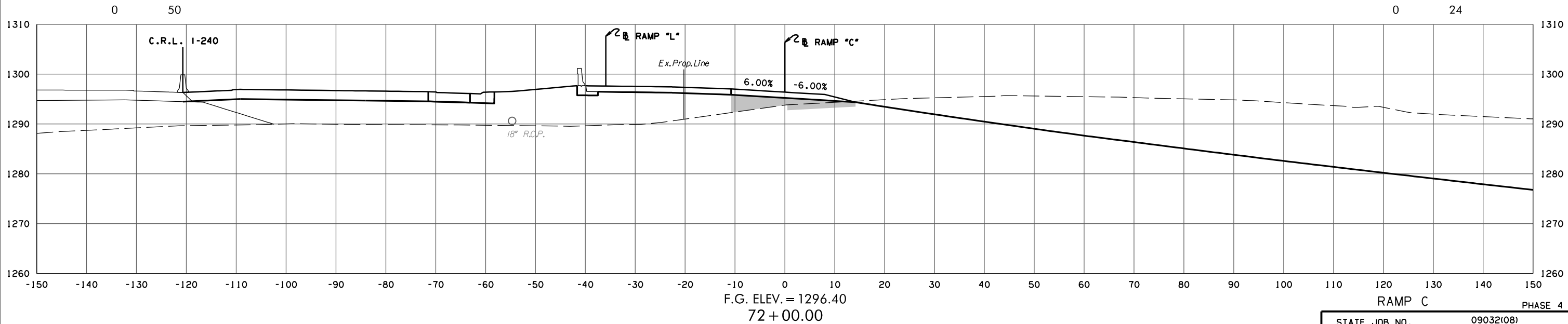
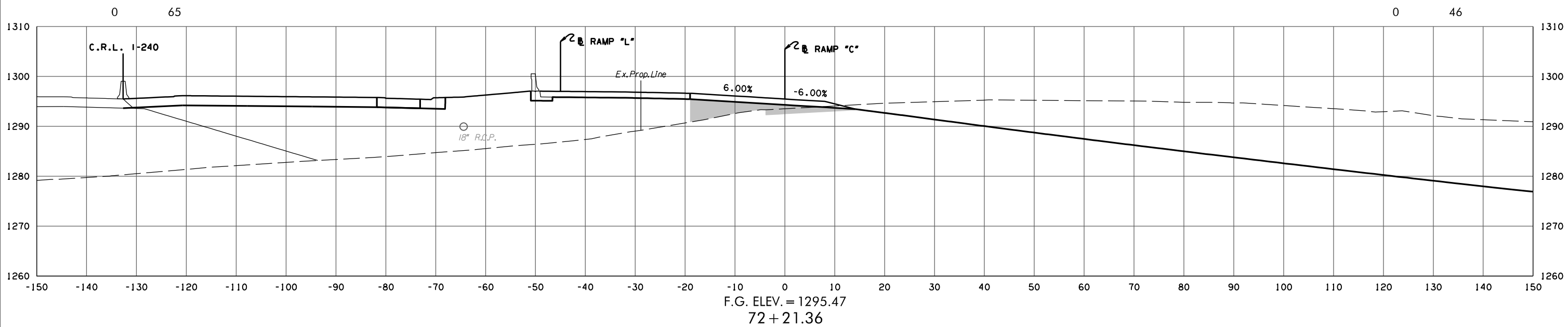

3/4/2024 3:57:45 PM H:\PROJECTS\2789_CrossRoads_Phase 4\Roadway\Drawings\Sections\0903208-XSEC_Ramp_C.dgn

STATE JOB NO. 09032(08)
 OKLAHOMA COUNTY SHEET NO. X152

(CAUTION) THE LOCATION OF ALL UTILITIES AS SHOWN ARE APPROXIMATE. DUE TO RELOCATION'S PLANNED OR PRESENTLY UNDER CONSTRUCTION THERE ARE SOME UTILITIES THAT WILL BE RELOCATED AND NOT SHOWN ON THESE PLANS. THE CONTRACTOR SHALL BE RESPONSIBLE FOR ANY DAMAGE TO ALL UTILITIES.

DEPTH & LOCATION OF EXISTING UTILITIES SHALL BE FIELD VERIFIED BY THE CONTRACTOR PRIOR TO CONSTRUCTION.

SEE DRAINAGE AREA MAP SHEETS FOR DRAINAGE SYMBOLOLOGY.

R/W & U/E PURCHASED UNDER JP 09032(05)

POB & ASSOCIATES, OKLAHOMA CITY, OK.

**90% PLAN
SUBMITTAL**

3/4/2024

AREA
CUT FILL

VOLUME
CUT FILL

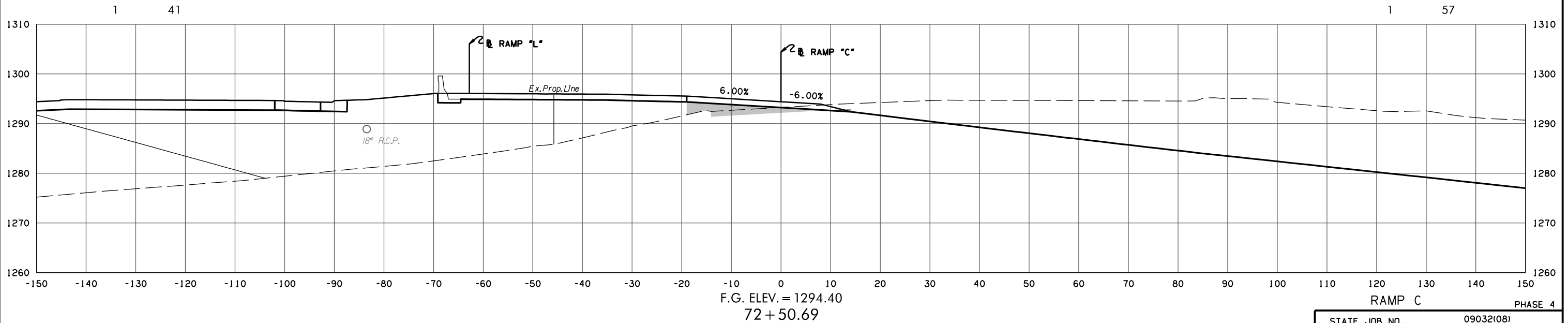
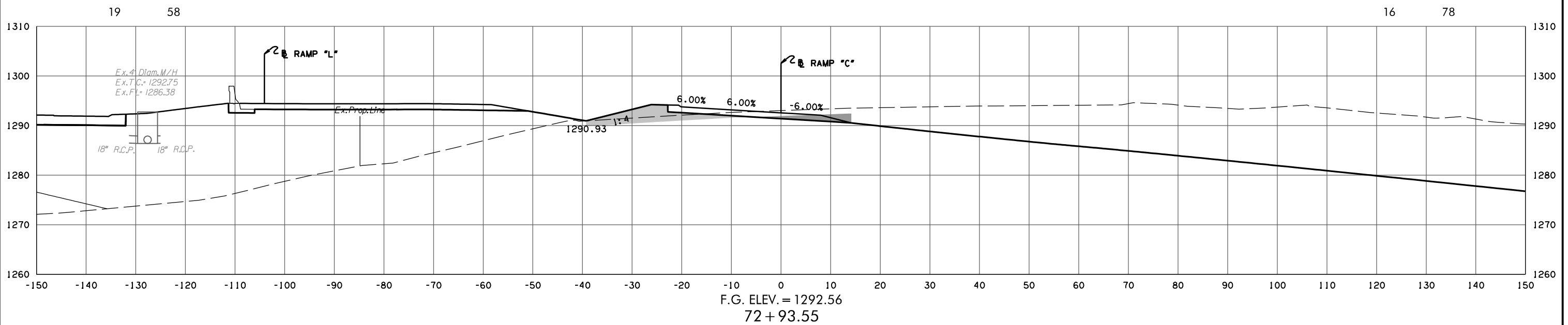

3/4/2024 3:57:46 PM H:\PROJECTS\2789_CrossRoads_Phase 4\Roadway\Drawings\Sections\0903208-XSEC_Ramp_C.dgn

(CAUTION) THE LOCATION OF ALL UTILITIES AS SHOWN ARE APPROXIMATE. DUE TO RELOCATION'S PLANNED OR PRESENTLY UNDER CONSTRUCTION THERE ARE SOME UTILITIES THAT WILL BE RELOCATED AND NOT SHOWN ON THESE PLANS. THE CONTRACTOR SHALL BE RESPONSIBLE FOR ANY DAMAGE TO ALL UTILITIES.
 DEPTH & LOCATION OF EXISTING UTILITIES SHALL BE FIELD VERIFIED BY THE CONTRACTOR PRIOR TO CONSTRUCTION.

SEE DRAINAGE AREA MAP SHEETS FOR DRAINAGE SYMBOLOLOGY.

R/W & U/E PURCHASED UNDER JP 09032(05)

POB & ASSOCIATES, OKLAHOMA CITY, OK.
90% PLAN SUBMITTAL
 3/4/2024

AREA
 CUT FILL

VOLUME
 CUT FILL

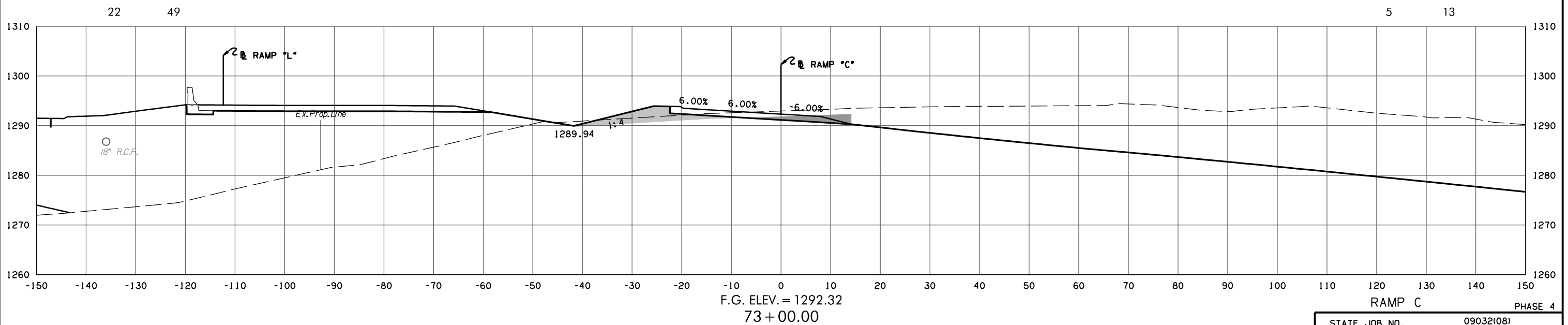
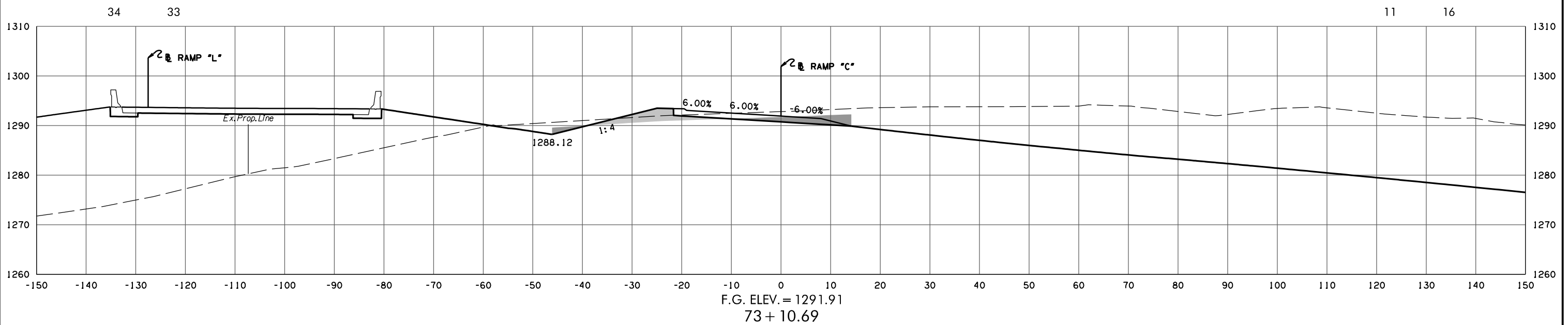

3/4/2024 3:57:47 PM H:\PROJECTS\2789_CrossRoads_Phase 4\Roadway\Drawings\Sections\0903208-XSEC_Ramp_C.dgn

RAMP C PHASE 4
 STATE JOB NO. 09032(08)
 OKLAHOMA COUNTY SHEET NO. X154

(CAUTION) THE LOCATION OF ALL UTILITIES AS SHOWN ARE APPROXIMATE. DUE TO RELOCATION'S PLANNED OR PRESENTLY UNDER CONSTRUCTION THERE ARE SOME UTILITIES THAT WILL BE RELOCATED AND NOT SHOWN ON THESE PLANS. THE CONTRACTOR SHALL BE RESPONSIBLE FOR ANY DAMAGE TO ALL UTILITIES.
 DEPTH & LOCATION OF EXISTING UTILITIES SHALL BE FIELD VERIFIED BY THE CONTRACTOR PRIOR TO CONSTRUCTION.

SEE DRAINAGE AREA MAP SHEETS FOR DRAINAGE SYMBOLOLOGY.

R/W & U/E PURCHASED UNDER JP 09032(05)

POB & ASSOCIATES, OKLAHOMA CITY, OK.
90% PLAN SUBMITTAL
 3/4/2024

AREA
 CUT FILL

VOLUME
 CUT FILL

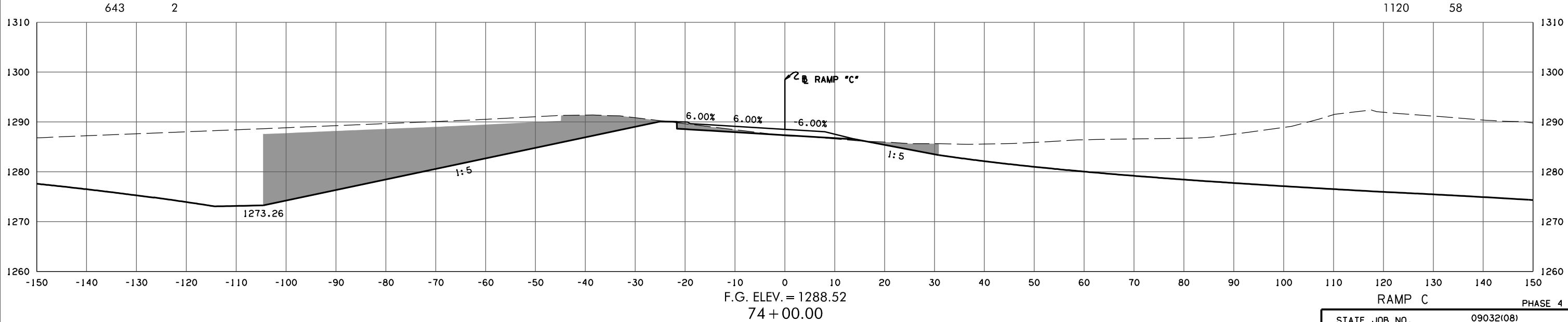
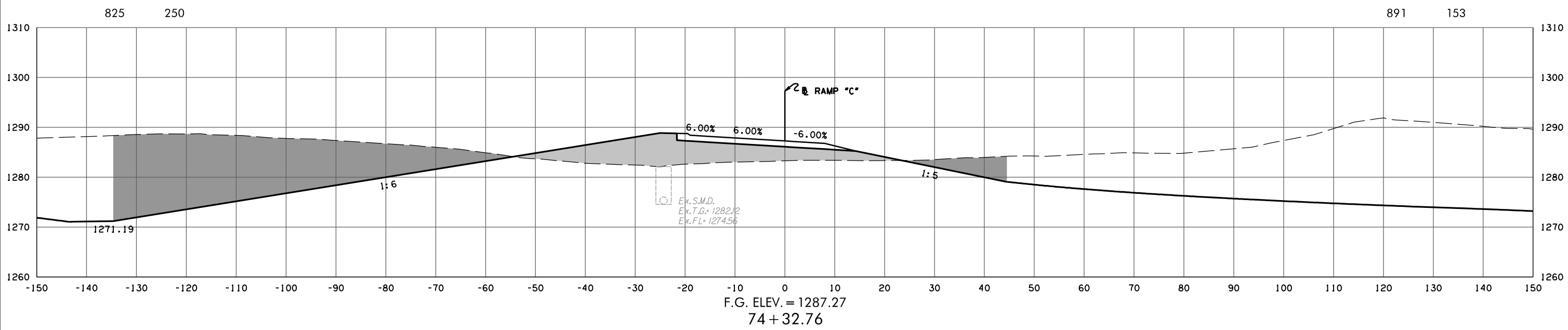

STATE JOB NO. 09032(08)
 OKLAHOMA COUNTY SHEET NO. X155

3/4/2024 3:57:48 PM
 H:\PROJECTS\2789_CrossRoads_Phase 4\Roadway\Drawings\Sections\0903208-XSEC_Ramp_C.dgn

(CAUTION) THE LOCATION OF ALL UTILITIES AS SHOWN ARE APPROXIMATE. DUE TO RELOCATION'S PLANNED OR PRESENTLY UNDER CONSTRUCTION THERE ARE SOME UTILITIES THAT WILL BE RELOCATED AND NOT SHOWN ON THESE PLANS. THE CONTRACTOR SHALL BE RESPONSIBLE FOR ANY DAMAGE TO ALL UTILITIES.

DEPTH & LOCATION OF EXISTING UTILITIES SHALL BE FIELD VERIFIED BY THE CONTRACTOR PRIOR TO CONSTRUCTION.

SEE DRAINAGE AREA MAP SHEETS FOR DRAINAGE SYMBOLOLOGY.

R/W & U/E PURCHASED UNDER JP 09032(05)

POB & ASSOCIATES, OKLAHOMA CITY, OK.

**90% PLAN
SUBMITTAL**

3/4/2024

AREA
CUT FILL

VOLUME
CUT FILL

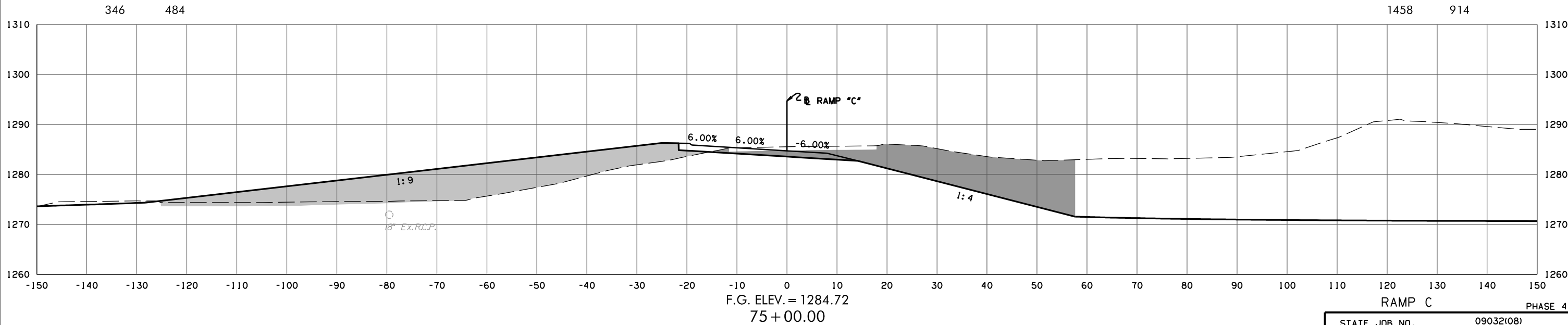
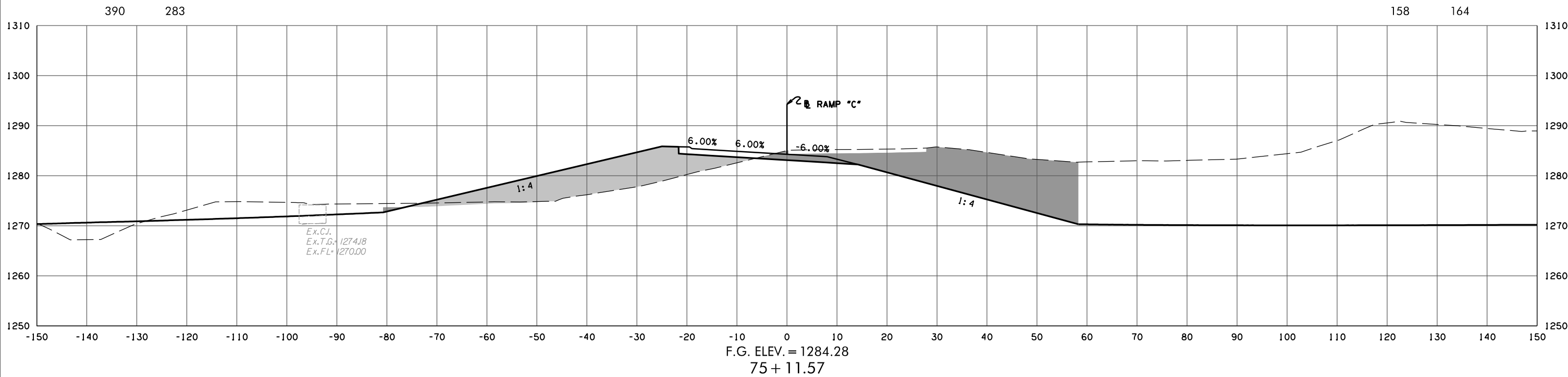

3/4/2024 3:57:48 PM H:\PROJECTS\2789_CrossRoads_Phase 4\Roadway\Drawings\Sections\0903208-XSEC_Ramp_C.dgn

(CAUTION) THE LOCATION OF ALL UTILITIES AS SHOWN ARE APPROXIMATE. DUE TO RELOCATION'S PLANNED OR PRESENTLY UNDER CONSTRUCTION THERE ARE SOME UTILITIES THAT WILL BE RELOCATED AND NOT SHOWN ON THESE PLANS. THE CONTRACTOR SHALL BE RESPONSIBLE FOR ANY DAMAGE TO ALL UTILITIES.
 DEPTH & LOCATION OF EXISTING UTILITIES SHALL BE FIELD VERIFIED BY THE CONTRACTOR PRIOR TO CONSTRUCTION.

SEE DRAINAGE AREA MAP SHEETS FOR DRAINAGE SYMBOLOLOGY.

R/W & U/E PURCHASED UNDER JP 09032(05)

POB & ASSOCIATES, OKLAHOMA CITY, OK.

90% PLAN SUBMITTAL

3/4/2024

AREA
 CUT FILL

VOLUME
 CUT FILL

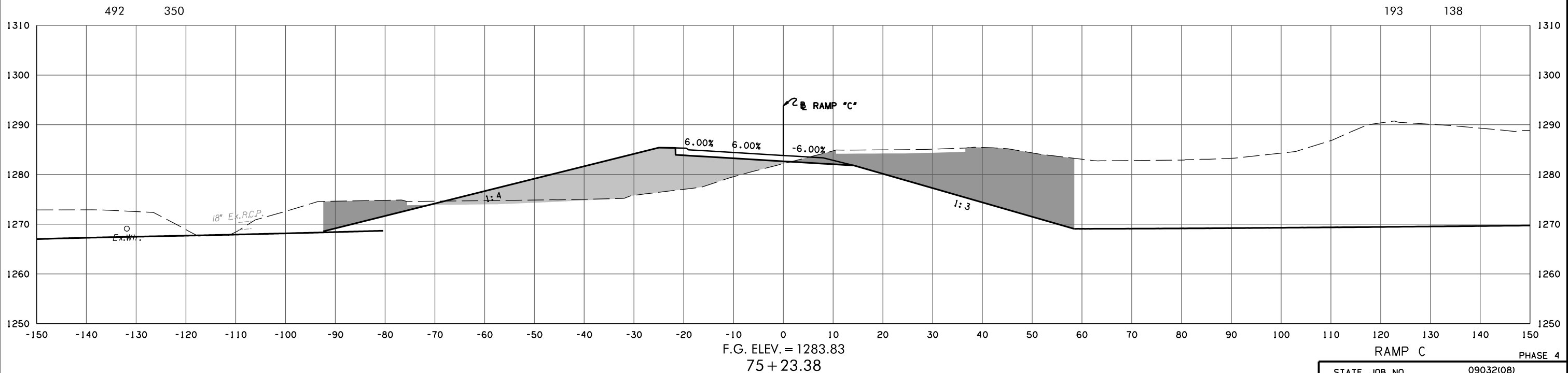
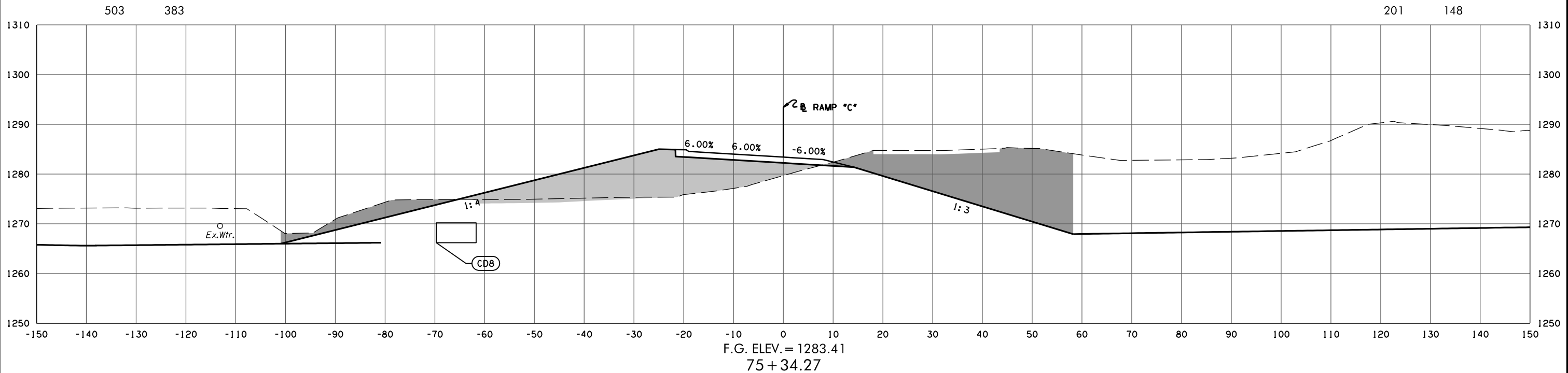

RAMP C PHASE 4
 STATE JOB NO. 09032(08)
 OKLAHOMA COUNTY SHEET NO. X157

3/4/2024 3:57:49 PM
 H:\PROJECTS\2789_CrossRoads_Phase 4\Roadway\Drawings\Sections\0903208-XSEC_Ramp_C.dgn

(CAUTION) THE LOCATION OF ALL UTILITIES AS SHOWN ARE APPROXIMATE. DUE TO RELOCATION'S PLANNED OR PRESENTLY UNDER CONSTRUCTION THERE ARE SOME UTILITIES THAT WILL BE RELOCATED AND NOT SHOWN ON THESE PLANS. THE CONTRACTOR SHALL BE RESPONSIBLE FOR ANY DAMAGE TO ALL UTILITIES.
 DEPTH & LOCATION OF EXISTING UTILITIES SHALL BE FIELD VERIFIED BY THE CONTRACTOR PRIOR TO CONSTRUCTION.

SEE DRAINAGE AREA MAP SHEETS FOR DRAINAGE SYMBOLOLOGY.

R/W & U/E PURCHASED UNDER JP 09032(05)

POB & ASSOCIATES, OKLAHOMA CITY, OK.
90% PLAN SUBMITTAL
 3/4/2024

AREA
 CUT FILL

VOLUME
 CUT FILL

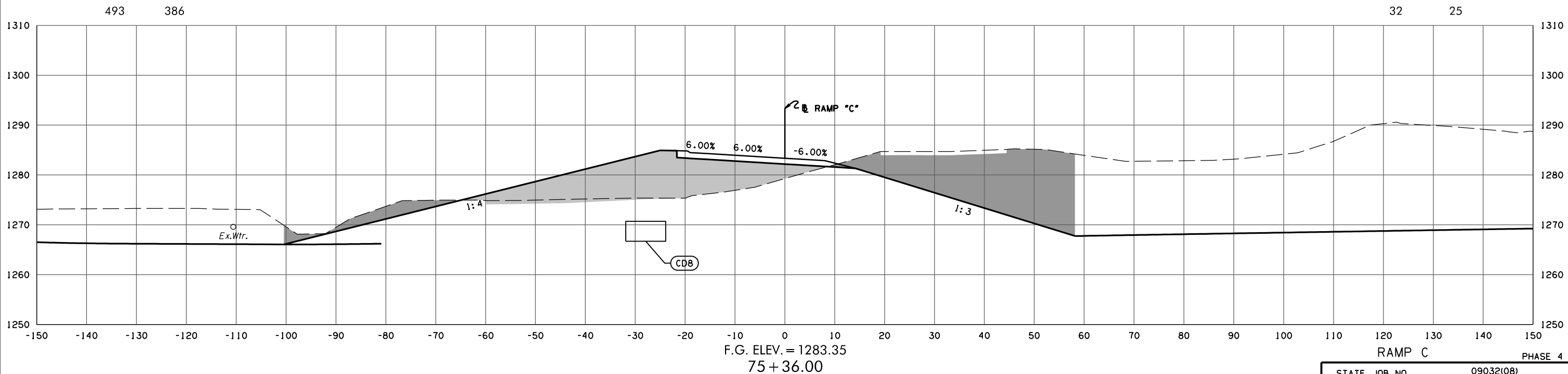
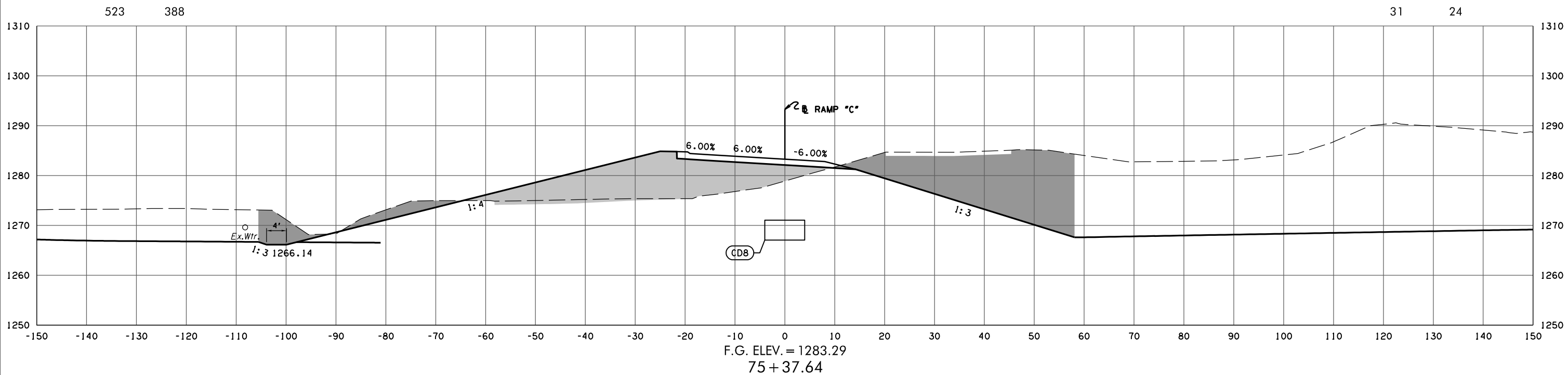

3/4/2024 3:57:50 PM H:\PROJECTS\2789_CrossRoads_Phase 4\Roadway\Drawings\Sections\0903208-XSEC_Ramp_C.dgn

STATE JOB NO. 09032(08)
 OKLAHOMA COUNTY SHEET NO. X158

(CAUTION) THE LOCATION OF ALL UTILITIES AS SHOWN ARE APPROXIMATE. DUE TO RELOCATION'S PLANNED OR PRESENTLY UNDER CONSTRUCTION THERE ARE SOME UTILITIES THAT WILL BE RELOCATED AND NOT SHOWN ON THESE PLANS. THE CONTRACTOR SHALL BE RESPONSIBLE FOR ANY DAMAGE TO ALL UTILITIES.
 DEPTH & LOCATION OF EXISTING UTILITIES SHALL BE FIELD VERIFIED BY THE CONTRACTOR PRIOR TO CONSTRUCTION.

SEE DRAINAGE AREA MAP SHEETS FOR DRAINAGE SYMBOLOLOGY.

R/W & U/E PURCHASED UNDER JP 09032(05)

POB & ASSOCIATES, OKLAHOMA CITY, OK.
90% PLAN SUBMITTAL
 3/4/2024

AREA
 CUT FILL

VOLUME
 CUT FILL

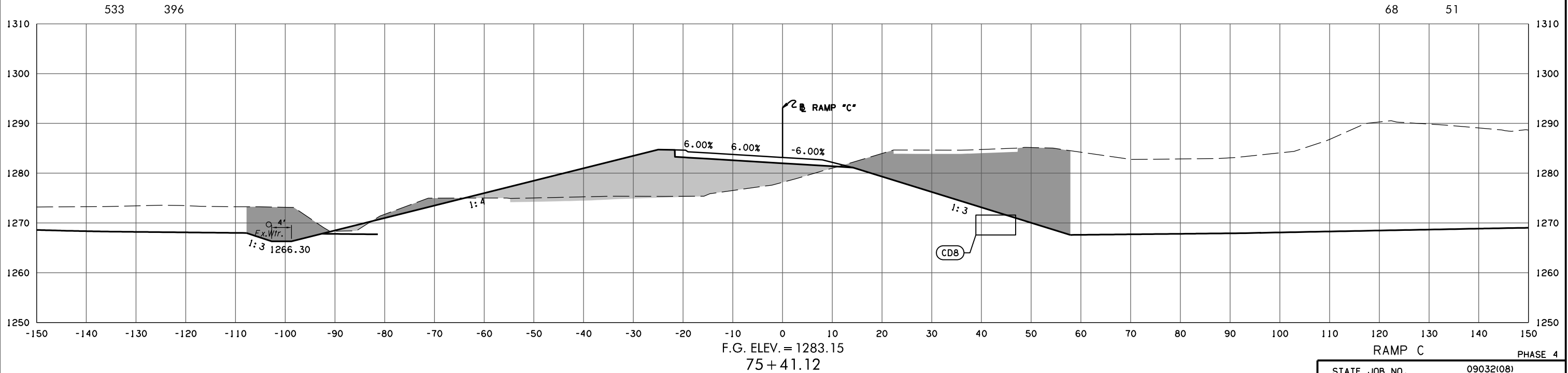
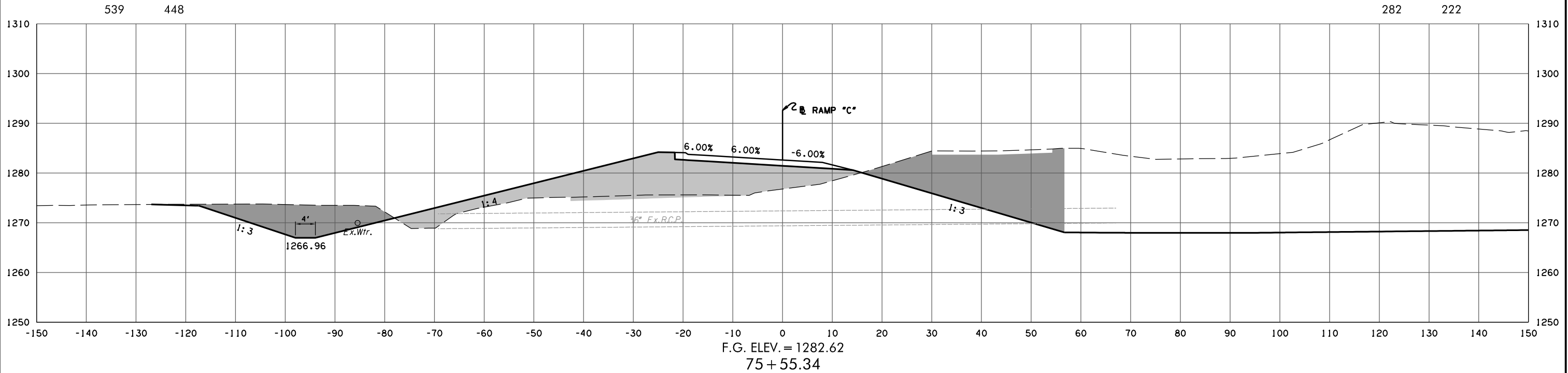

RAMP C PHASE 4
 STATE JOB NO. 09032(08)
 OKLAHOMA COUNTY SHEET NO. X159

3/4/2024 3:57:51 PM
 H:\PROJECTS\2789_CrossRoads_Phase 4\Roadway\Drawings\Sections\0903208-XSEC_Ramp_C.dgn

(CAUTION) THE LOCATION OF ALL UTILITIES AS SHOWN ARE APPROXIMATE. DUE TO RELOCATION'S PLANNED OR PRESENTLY UNDER CONSTRUCTION THERE ARE SOME UTILITIES THAT WILL BE RELOCATED AND NOT SHOWN ON THESE PLANS. THE CONTRACTOR SHALL BE RESPONSIBLE FOR ANY DAMAGE TO ALL UTILITIES.

DEPTH & LOCATION OF EXISTING UTILITIES SHALL BE FIELD VERIFIED BY THE CONTRACTOR PRIOR TO CONSTRUCTION.

SEE DRAINAGE AREA MAP SHEETS FOR DRAINAGE SYMBOLOLOGY.

R/W & U/E PURCHASED UNDER JP 09032(05)

POB & ASSOCIATES, OKLAHOMA CITY, OK.

**90% PLAN
SUBMITTAL**

3/4/2024

AREA
CUT FILL

VOLUME
CUT FILL

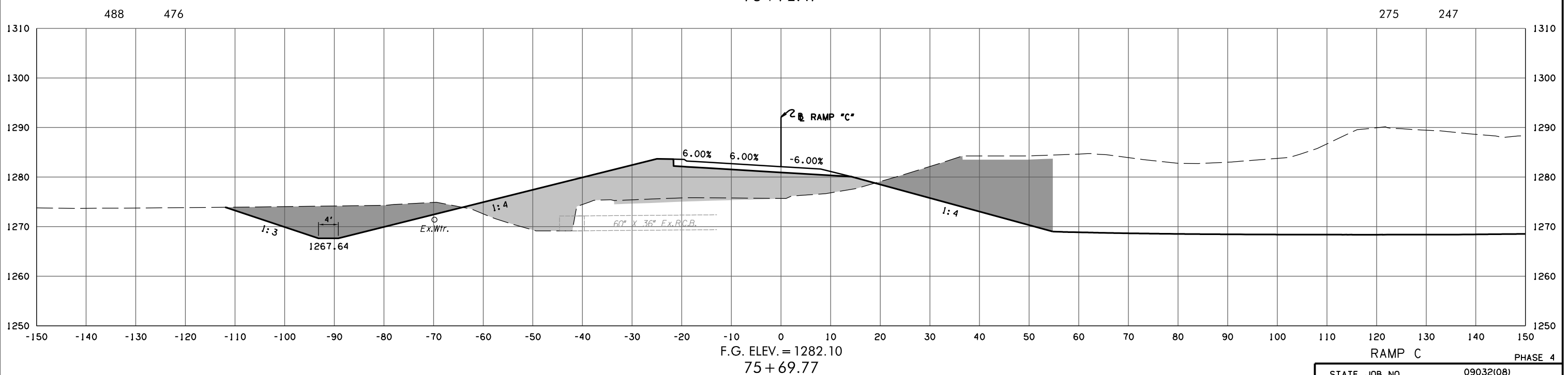
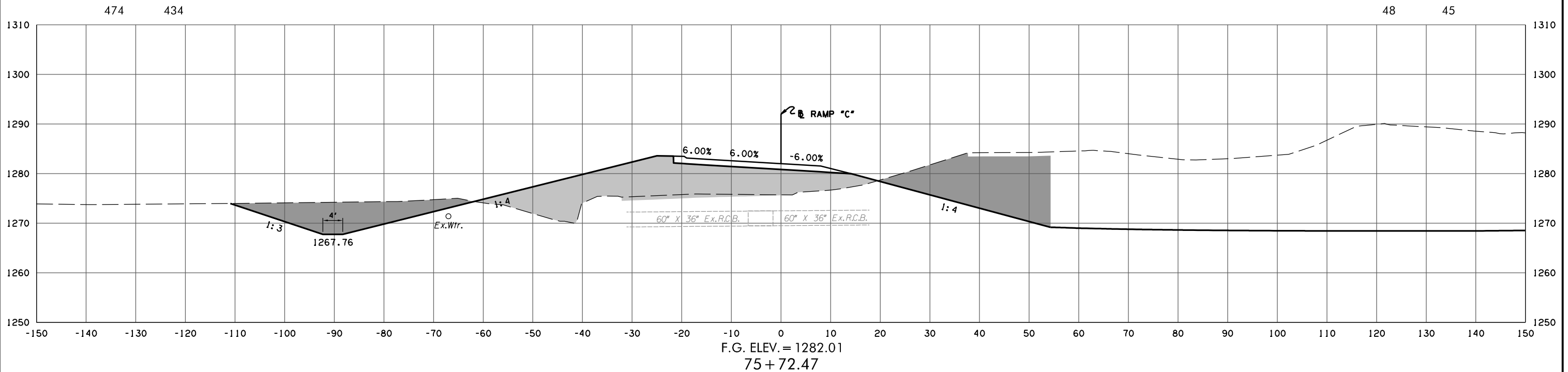

RAMP C PHASE 4
STATE JOB NO. 09032(08)
OKLAHOMA COUNTY SHEET NO. X160

3/4/2024 3:57:51 PM H:\PROJECTS\2789_CrossRoads_Phase 4\Roadway\Drawings\Sections\0903208-XSEC_Ramp_C.dgn

(CAUTION) THE LOCATION OF ALL UTILITIES AS SHOWN ARE APPROXIMATE. DUE TO RELOCATION'S PLANNED OR PRESENTLY UNDER CONSTRUCTION THERE ARE SOME UTILITIES THAT WILL BE RELOCATED AND NOT SHOWN ON THESE PLANS. THE CONTRACTOR SHALL BE RESPONSIBLE FOR ANY DAMAGE TO ALL UTILITIES.

DEPTH & LOCATION OF EXISTING UTILITIES SHALL BE FIELD VERIFIED BY THE CONTRACTOR PRIOR TO CONSTRUCTION.

SEE DRAINAGE AREA MAP SHEETS FOR DRAINAGE SYMBOLOLOGY.

R/W & U/E PURCHASED UNDER JP 09032(05)

POB & ASSOCIATES, OKLAHOMA CITY, OK.

**90% PLAN
SUBMITTAL**

3/4/2024

AREA
CUT FILL

VOLUME
CUT FILL

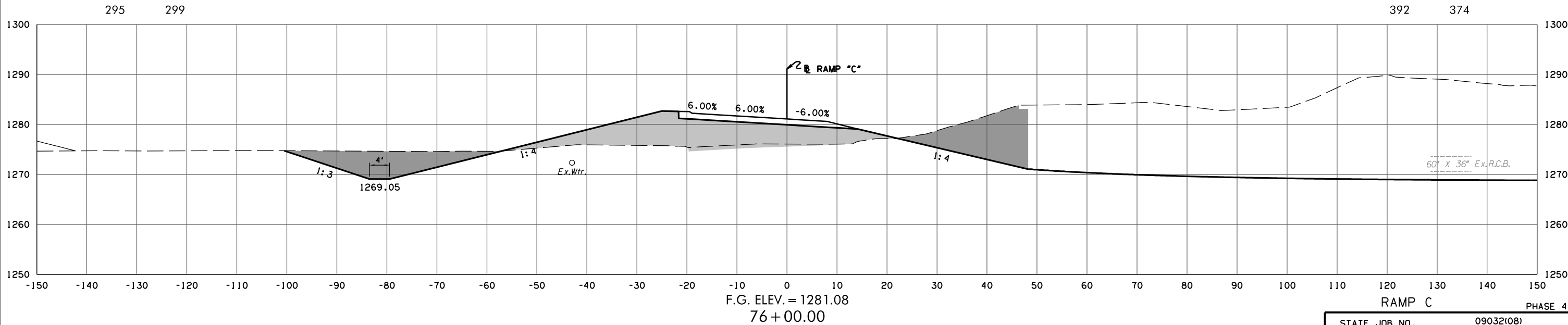
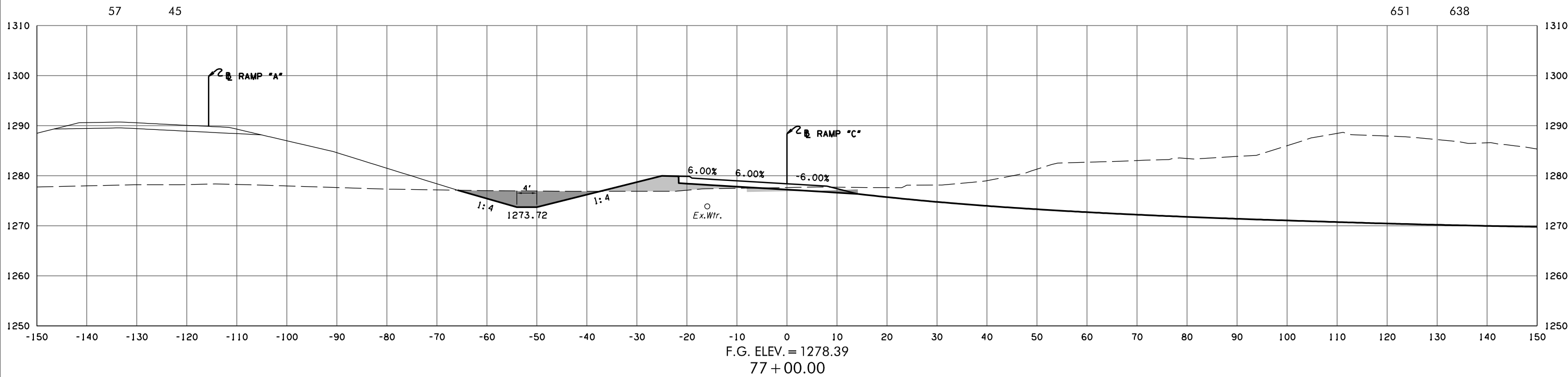

RAMP C PHASE 4

STATE JOB NO. 09032(08)
OKLAHOMA COUNTY SHEET NO. X16

3/4/2024 3:57:52 PM H:\PROJECTS\2789_CrossRoads_Phase 4\Roadway\Drawings\Sections\0903208-XSEC_Ramp_C.dgn

(CAUTION) THE LOCATION OF ALL UTILITIES AS SHOWN ARE APPROXIMATE. DUE TO RELOCATION'S PLANNED OR PRESENTLY UNDER CONSTRUCTION THERE ARE SOME UTILITIES THAT WILL BE RELOCATED AND NOT SHOWN ON THESE PLANS. THE CONTRACTOR SHALL BE RESPONSIBLE FOR ANY DAMAGE TO ALL UTILITIES. DEPTH & LOCATION OF EXISTING UTILITIES SHALL BE FIELD VERIFIED BY THE CONTRACTOR PRIOR TO CONSTRUCTION.

SEE DRAINAGE AREA MAP SHEETS FOR DRAINAGE SYMBOLOLOGY.

R/W & U/E PURCHASED UNDER JP 09032(05)

POB & ASSOCIATES, OKLAHOMA CITY, OK.
90% PLAN
SUBMITTAL
 3/4/2024

AREA
 CUT FILL

VOLUME
 CUT FILL

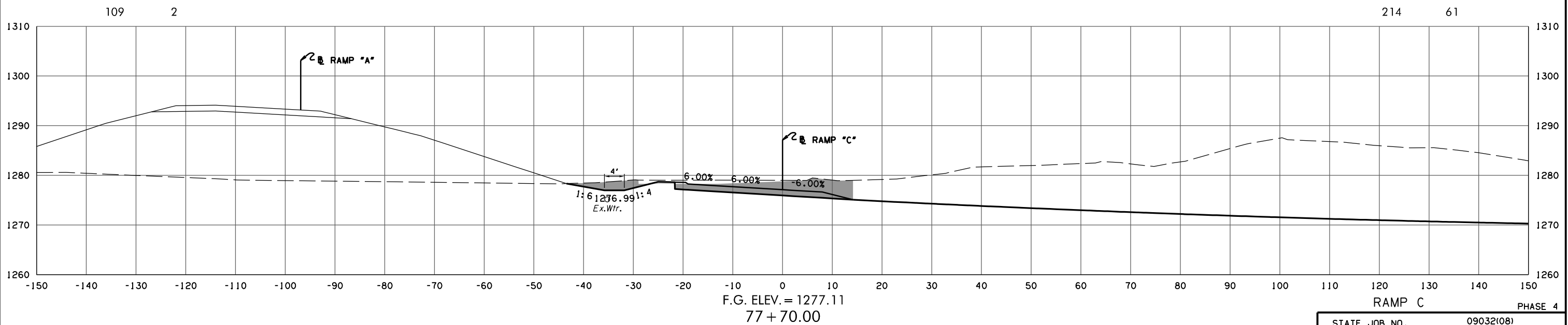
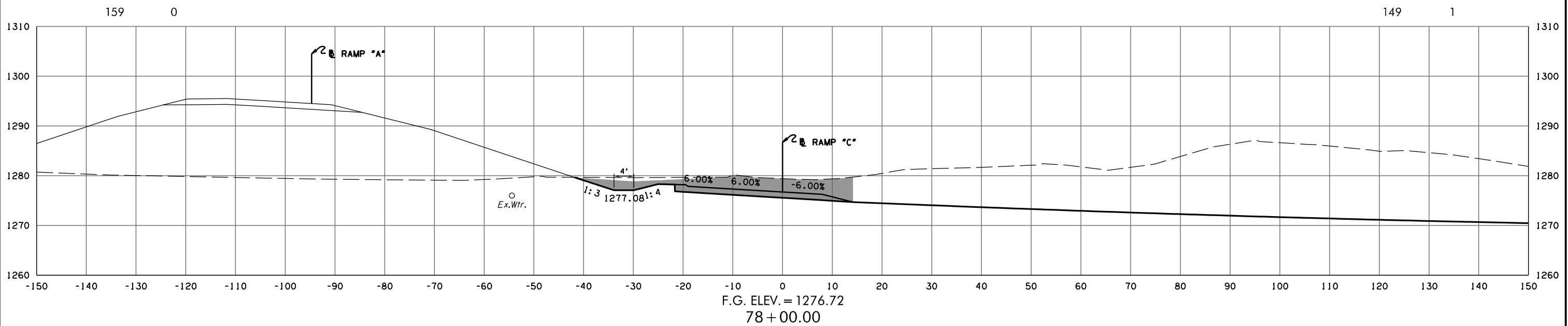

RAMP C PHASE 4
 STATE JOB NO. 09032(08)
 OKLAHOMA COUNTY SHEET NO. X162

3/4/2024 3:57:53 PM
 H:\PROJECTS\2789_CrossRoads_Phase 4\Roadway\Drawings\Sections\0903208-XSEC_Ramp_C.dgn

(CAUTION) THE LOCATION OF ALL UTILITIES AS SHOWN ARE APPROXIMATE. DUE TO RELOCATION'S PLANNED OR PRESENTLY UNDER CONSTRUCTION THERE ARE SOME UTILITIES THAT WILL BE RELOCATED AND NOT SHOWN ON THESE PLANS. THE CONTRACTOR SHALL BE RESPONSIBLE FOR ANY DAMAGE TO ALL UTILITIES. DEPTH & LOCATION OF EXISTING UTILITIES SHALL BE FIELD VERIFIED BY THE CONTRACTOR PRIOR TO CONSTRUCTION.

SEE DRAINAGE AREA MAP SHEETS FOR DRAINAGE SYMBOLOLOGY.

R/W & U/E PURCHASED UNDER JP 09032(05)

POB & ASSOCIATES, OKLAHOMA CITY, OK.

**90% PLAN
SUBMITTAL**

3/4/2024

AREA
CUT FILL

VOLUME
CUT FILL

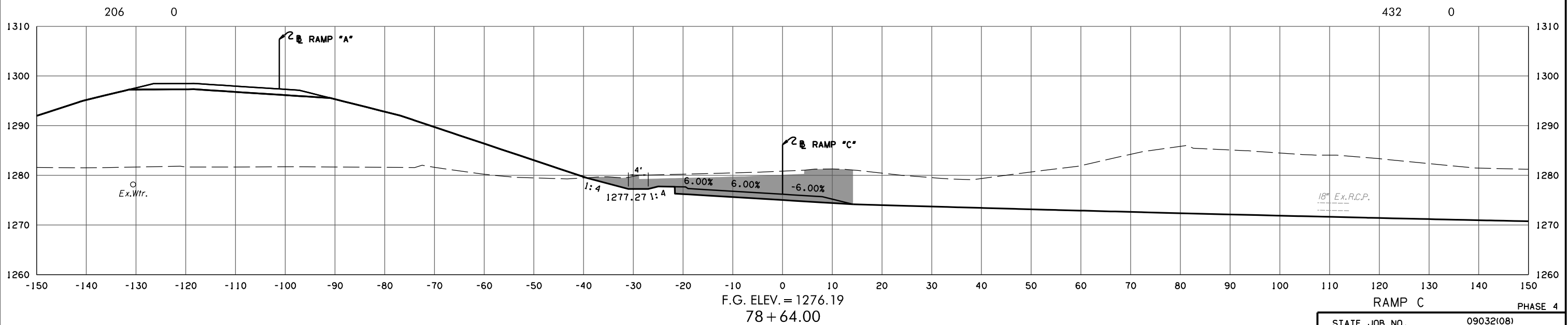
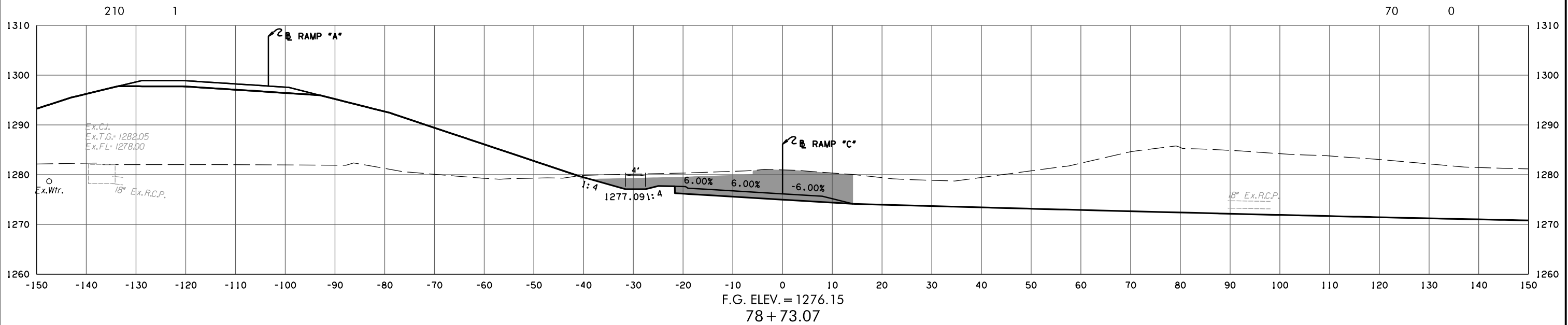

RAMP C PHASE 4

STATE JOB NO. 09032(08)
OKLAHOMA COUNTY SHEET NO. X163

3/4/2024 3:57:54 PM H:\PROJECTS\2789_CrossRoads_Phase 4\Roadway\Drawings\Sections\0903208-XSEC_Ramp_C.dgn

(CAUTION) THE LOCATION OF ALL UTILITIES AS SHOWN ARE APPROXIMATE. DUE TO RELOCATION'S PLANNED OR PRESENTLY UNDER CONSTRUCTION THERE ARE SOME UTILITIES THAT WILL BE RELOCATED AND NOT SHOWN ON THESE PLANS. THE CONTRACTOR SHALL BE RESPONSIBLE FOR ANY DAMAGE TO ALL UTILITIES.

SEE DRAINAGE AREA MAP SHEETS FOR DRAINAGE SYMBOLOLOGY.

R/W & U/E PURCHASED UNDER JP 09032(05)

POB & ASSOCIATES, OKLAHOMA CITY, OK.

**90% PLAN
SUBMITTAL**

3/4/2024

DEPTH & LOCATION OF EXISTING UTILITIES SHALL BE FIELD VERIFIED BY THE CONTRACTOR PRIOR TO CONSTRUCTION.

AREA
CUT FILL

VOLUME
CUT FILL

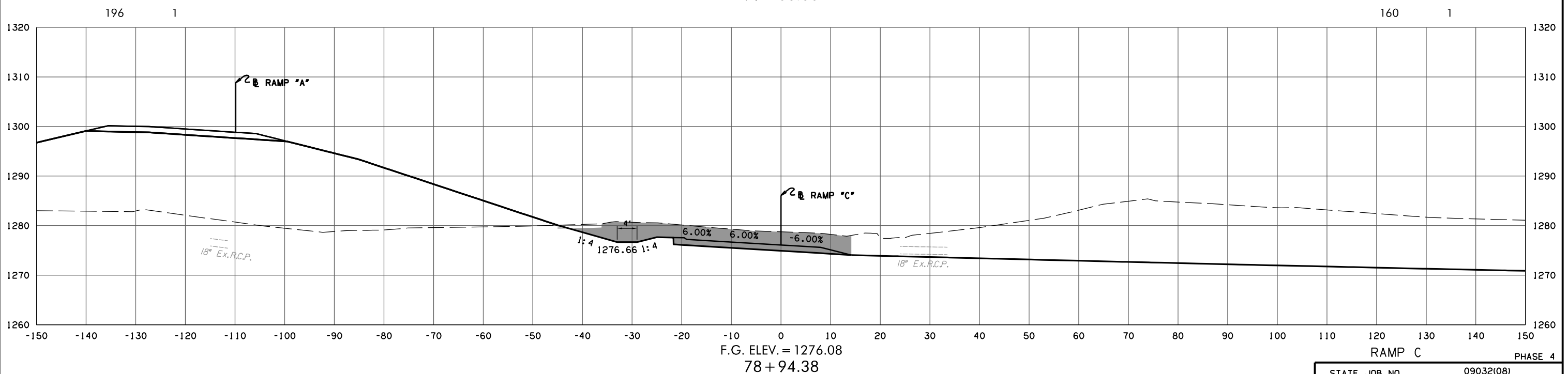
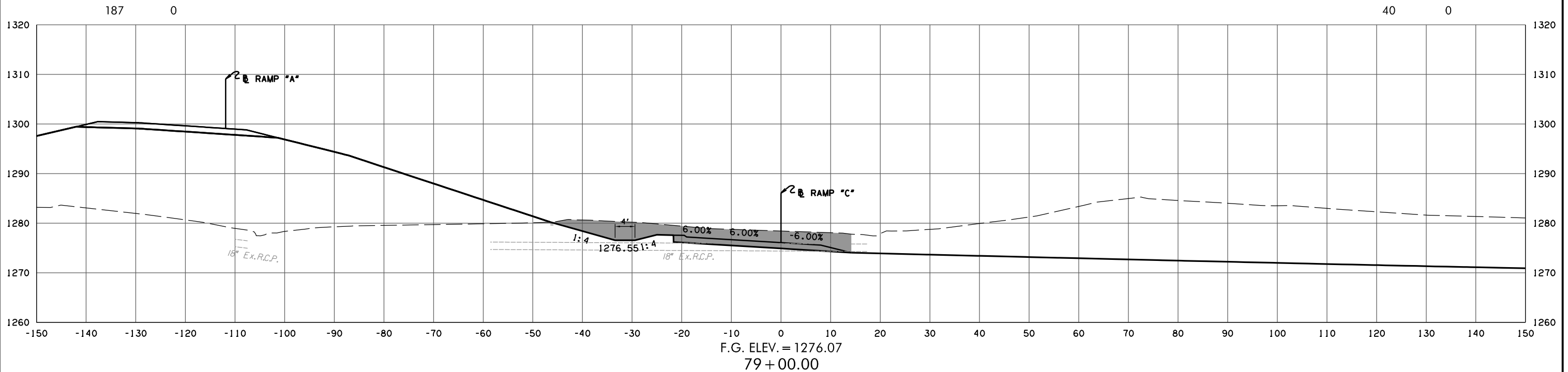

3/4/2024 3:57:55 PM H:\PROJECTS\2789_CrossRoads_Phase 4\Roadway\Drawings\Sections\0903208-XSEC_Ramp_C.dgn

(CAUTION) THE LOCATION OF ALL UTILITIES AS SHOWN ARE APPROXIMATE. DUE TO RELOCATION'S PLANNED OR PRESENTLY UNDER CONSTRUCTION THERE ARE SOME UTILITIES THAT WILL BE RELOCATED AND NOT SHOWN ON THESE PLANS. THE CONTRACTOR SHALL BE RESPONSIBLE FOR ANY DAMAGE TO ALL UTILITIES.
 DEPTH & LOCATION OF EXISTING UTILITIES SHALL BE FIELD VERIFIED BY THE CONTRACTOR PRIOR TO CONSTRUCTION.

SEE DRAINAGE AREA MAP SHEETS FOR DRAINAGE SYMBOLOLOGY.

R/W & U/E PURCHASED UNDER JP 09032(05)

POB & ASSOCIATES, OKLAHOMA CITY, OK.
90% PLAN SUBMITTAL
 3/4/2024

AREA
 CUT FILL

VOLUME
 CUT FILL

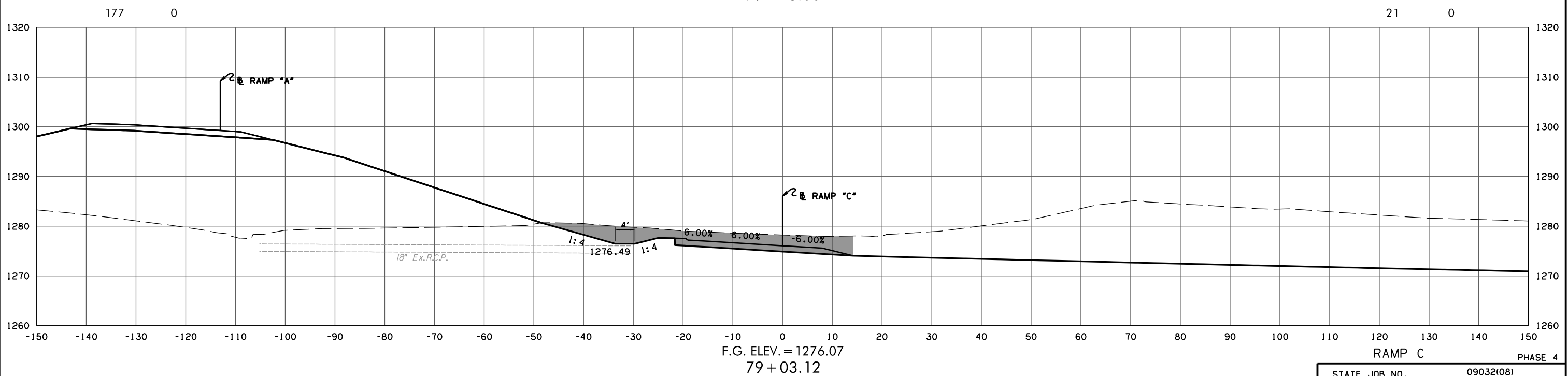
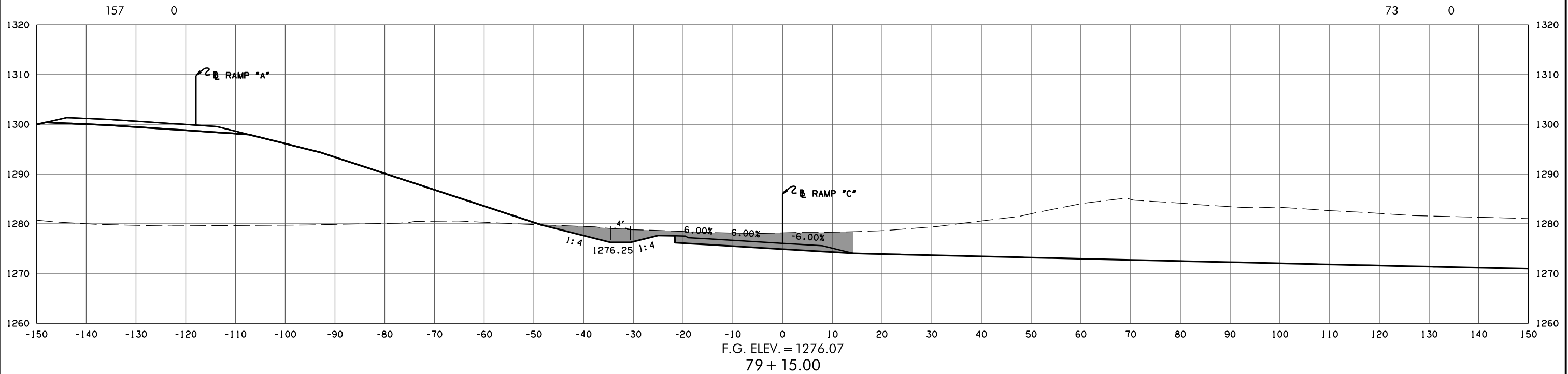

RAMP C PHASE 4
 STATE JOB NO. 09032(08)
 OKLAHOMA COUNTY SHEET NO. X165

3/4/2024 3:57:55 PM
 H:\PROJECTS\2789_CrossRoads_Phase 4\Roadway\Drawings\Sections\0903208-XSEC_Ramp_C.dgn

(CAUTION) THE LOCATION OF ALL UTILITIES AS SHOWN ARE APPROXIMATE. DUE TO RELOCATION'S PLANNED OR PRESENTLY UNDER CONSTRUCTION THERE ARE SOME UTILITIES THAT WILL BE RELOCATED AND NOT SHOWN ON THESE PLANS. THE CONTRACTOR SHALL BE RESPONSIBLE FOR ANY DAMAGE TO ALL UTILITIES.

DEPTH & LOCATION OF EXISTING UTILITIES SHALL BE FIELD VERIFIED BY THE CONTRACTOR PRIOR TO CONSTRUCTION.

SEE DRAINAGE AREA MAP SHEETS FOR DRAINAGE SYMBOLOLOGY.

R/W & U/E PURCHASED UNDER JP 09032(05)

POB & ASSOCIATES, OKLAHOMA CITY, OK.

**90% PLAN
SUBMITTAL**

3/4/2024

AREA
CUT FILL

VOLUME
CUT FILL

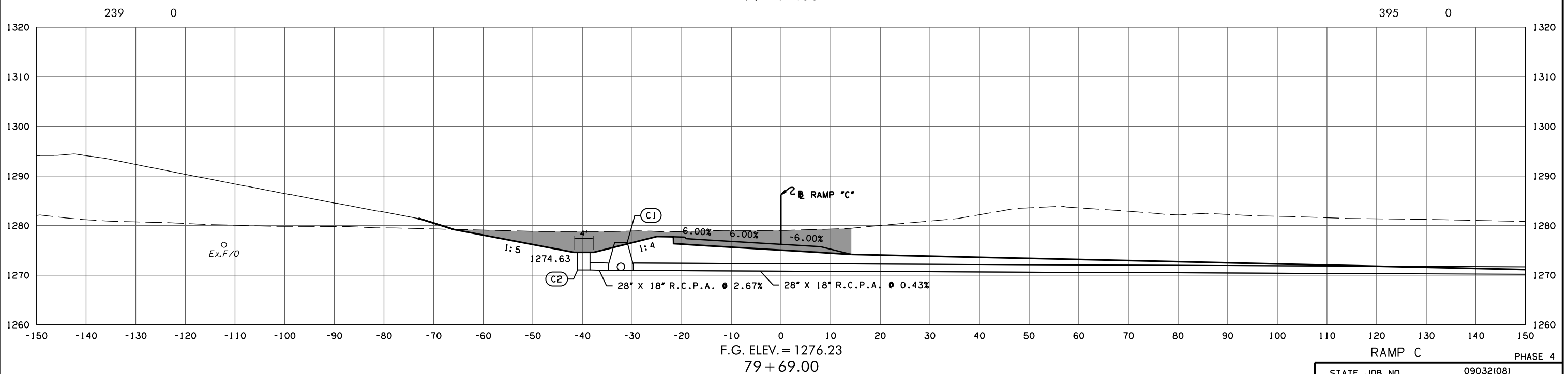
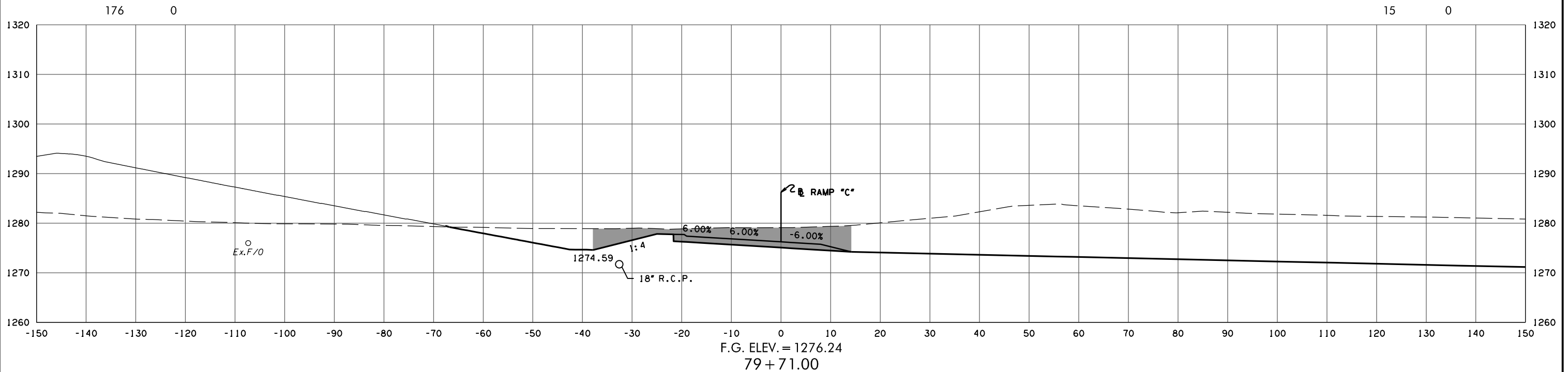

RAMP C PHASE 4

STATE JOB NO. 09032(08)
OKLAHOMA COUNTY SHEET NO. X166

3/4/2024 3:57:56 PM
H:\PROJECTS\2789_CrossRoads_Phase 4\Roadway\Drawings\Sections\0903208-XSEC_Ramp_C.dgn

(CAUTION) THE LOCATION OF ALL UTILITIES AS SHOWN ARE APPROXIMATE. DUE TO RELOCATION'S PLANNED OR PRESENTLY UNDER CONSTRUCTION THERE ARE SOME UTILITIES THAT WILL BE RELOCATED AND NOT SHOWN ON THESE PLANS. THE CONTRACTOR SHALL BE RESPONSIBLE FOR ANY DAMAGE TO ALL UTILITIES.
 DEPTH & LOCATION OF EXISTING UTILITIES SHALL BE FIELD VERIFIED BY THE CONTRACTOR PRIOR TO CONSTRUCTION.

SEE DRAINAGE AREA MAP SHEETS FOR DRAINAGE SYMBOLOLOGY.

R/W & U/E PURCHASED UNDER JP 09032(05)

POB & ASSOCIATES, OKLAHOMA CITY, OK.

90% PLAN SUBMITTAL

3/4/2024

AREA
 CUT FILL

VOLUME
 CUT FILL

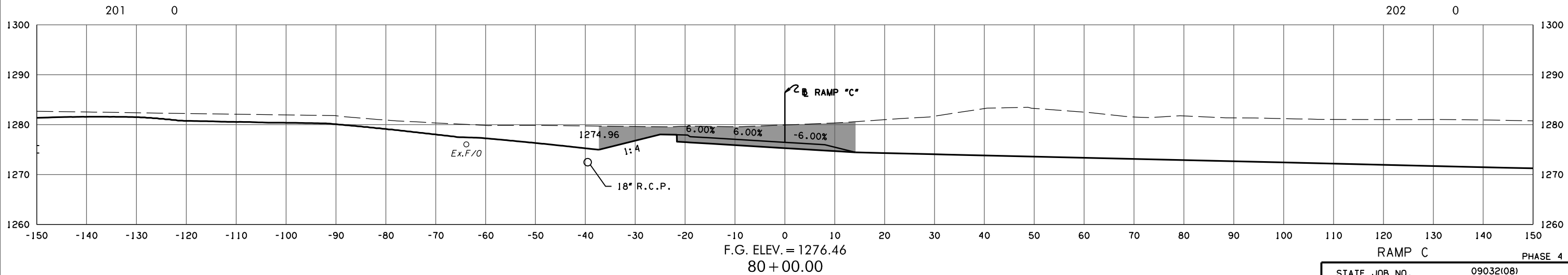
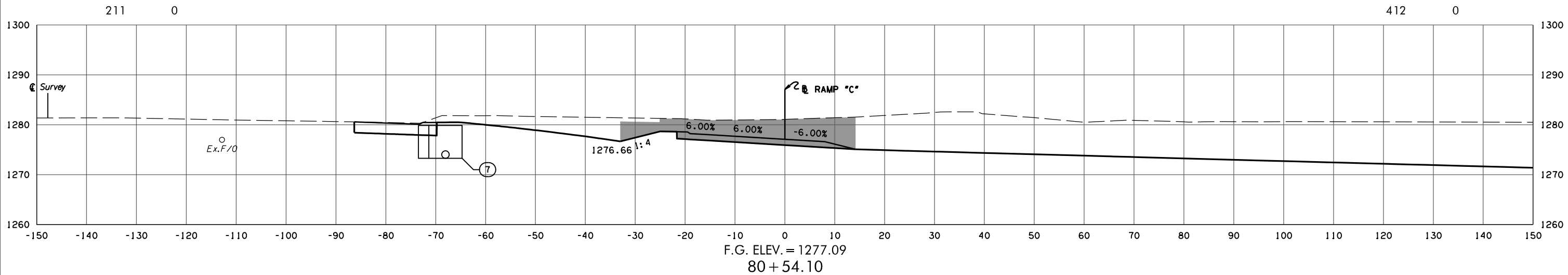
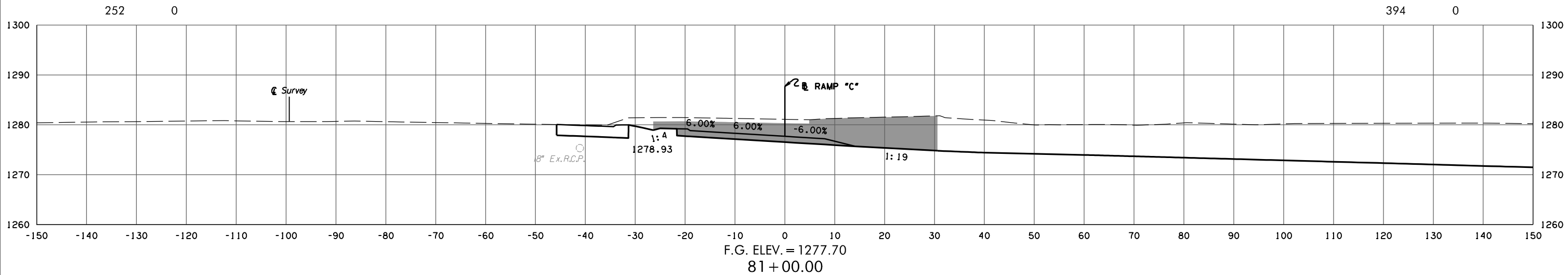

3/4/2024 3:57:57 PM H:\PROJECTS\2789_CrossRoads_Phase 4\Roadway\Drawings\Sections\0903208-XSEC_Ramp_C.dgn

(CAUTION) THE LOCATION OF ALL UTILITIES AS SHOWN ARE APPROXIMATE. DUE TO RELOCATION'S PLANNED OR PRESENTLY UNDER CONSTRUCTION THERE ARE SOME UTILITIES THAT WILL BE RELOCATED AND NOT SHOWN ON THESE PLANS. THE CONTRACTOR SHALL BE RESPONSIBLE FOR ANY DAMAGE TO ALL UTILITIES.
 DEPTH & LOCATION OF EXISTING UTILITIES SHALL BE FIELD VERIFIED BY THE CONTRACTOR PRIOR TO CONSTRUCTION.

SEE DRAINAGE AREA MAP SHEETS FOR DRAINAGE SYMBOLOLOGY.

R/W & U/E PURCHASED UNDER JP 09032(05)

POB & ASSOCIATES, OKLAHOMA CITY, OK.
90% PLAN SUBMITTAL
 3/4/2024

AREA
 CUT FILL

VOLUME
 CUT FILL

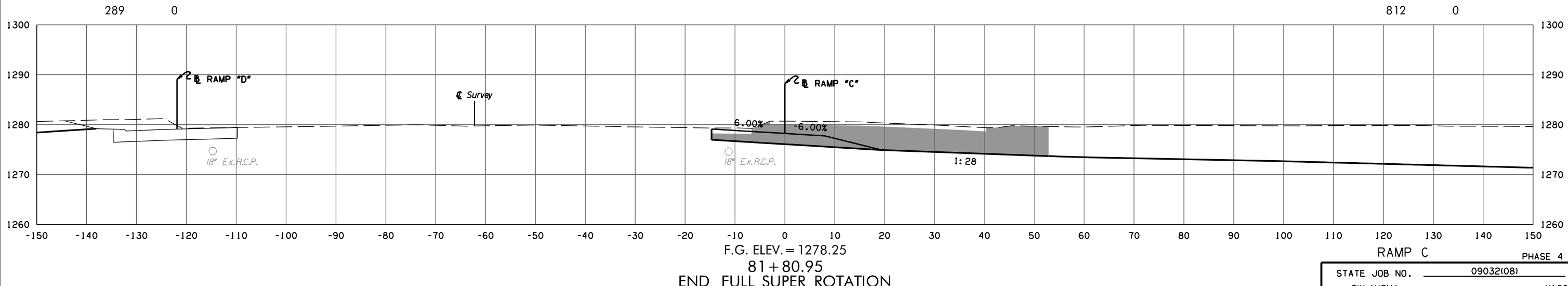
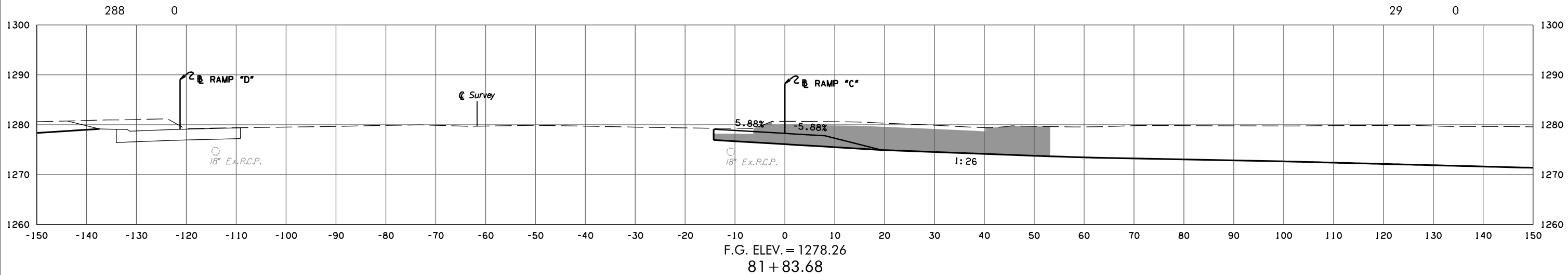
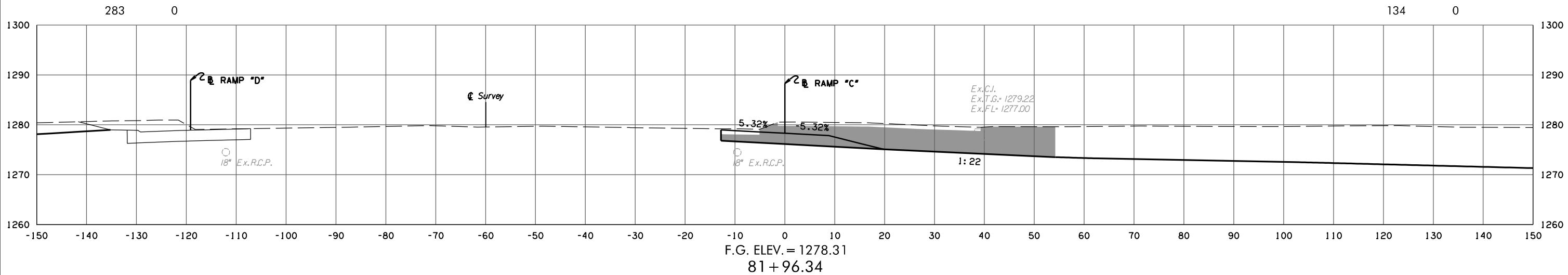

3/4/2024 3:57:58 PM H:\PROJECTS\2789_CrossRoads_Phase 4\Roadway\Drawings\Sections\0903208-XSEC_Ramp_C.dgn

STATE JOB NO. 09032(08)
 OKLAHOMA COUNTY SHEET NO. X168

RAMP C PHASE 4
 F.G. ELEV. = 1278.25
 81+80.95
 END FULL SUPER ROTATION

(CAUTION) THE LOCATION OF ALL UTILITIES AS SHOWN ARE APPROXIMATE. DUE TO RELOCATION'S PLANNED OR PRESENTLY UNDER CONSTRUCTION THERE ARE SOME UTILITIES THAT WILL BE RELOCATED AND NOT SHOWN ON THESE PLANS. THE CONTRACTOR SHALL BE RESPONSIBLE FOR ANY DAMAGE TO ALL UTILITIES.

DEPTH & LOCATION OF EXISTING UTILITIES SHALL BE FIELD VERIFIED BY THE CONTRACTOR PRIOR TO CONSTRUCTION.

SEE DRAINAGE AREA MAP SHEETS FOR DRAINAGE SYMBOLOLOGY.

R/W & U/E PURCHASED UNDER JP 09032(05)

POB & ASSOCIATES, OKLAHOMA CITY, OK.

**90% PLAN
SUBMITTAL**

3/4/2024

AREA
CUT FILL

VOLUME
CUT FILL

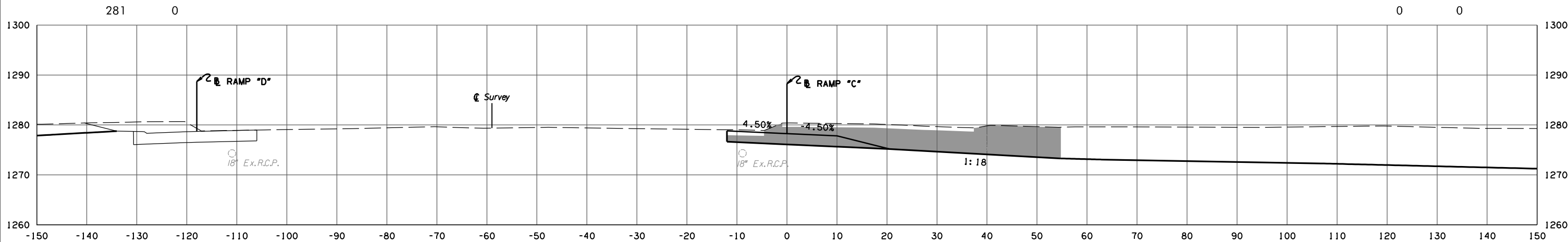

F.G. ELEV. = 1278.27
82 + 15.04

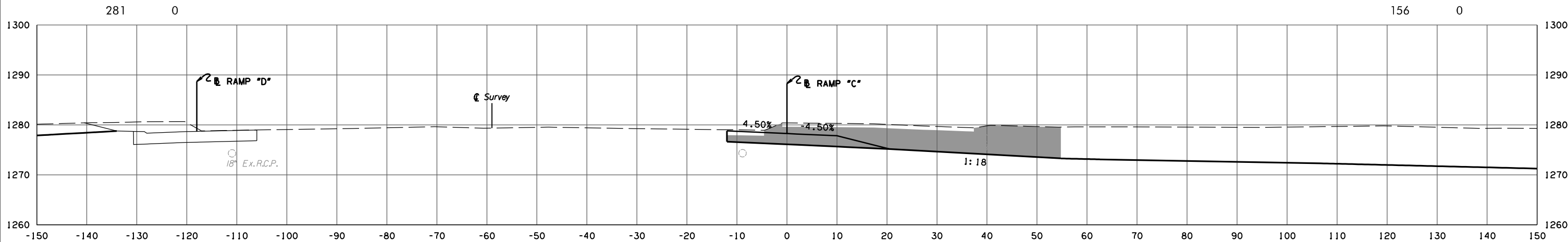

F.G. ELEV. = 1278.27
82 + 15.00

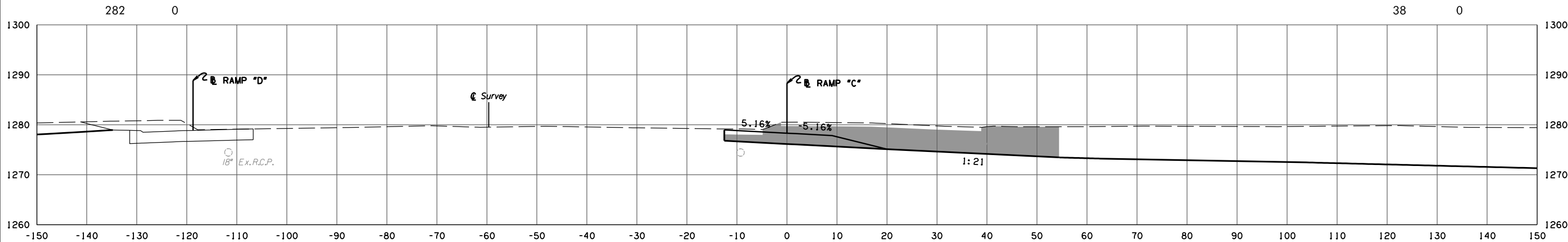

F.G. ELEV. = 1278.32
82 + 00.00

RAMP C PHASE 4

STATE JOB NO. 09032(08)
OKLAHOMA COUNTY SHEET NO. X169

3/4/2024 3:57:58 PM H:\PROJECTS\2789_CrossRoads_Phase 4\Roadway\Drawings\Sections\0903208-XSEC_Ramp_C.dgn

(CAUTION) THE LOCATION OF ALL UTILITIES AS SHOWN ARE APPROXIMATE. DUE TO RELOCATION'S PLANNED OR PRESENTLY UNDER CONSTRUCTION THERE ARE SOME UTILITIES THAT WILL BE RELOCATED AND NOT SHOWN ON THESE PLANS. THE CONTRACTOR SHALL BE RESPONSIBLE FOR ANY DAMAGE TO ALL UTILITIES.

DEPTH & LOCATION OF EXISTING UTILITIES SHALL BE FIELD VERIFIED BY THE CONTRACTOR PRIOR TO CONSTRUCTION.

SEE DRAINAGE AREA MAP SHEETS FOR DRAINAGE SYMBOLOLOGY.

R/W & U/E PURCHASED UNDER JP 09032(05)

POB & ASSOCIATES, OKLAHOMA CITY, OK.

**90% PLAN
SUBMITTAL**

3/4/2024

AREA
CUT FILL

VOLUME
CUT FILL

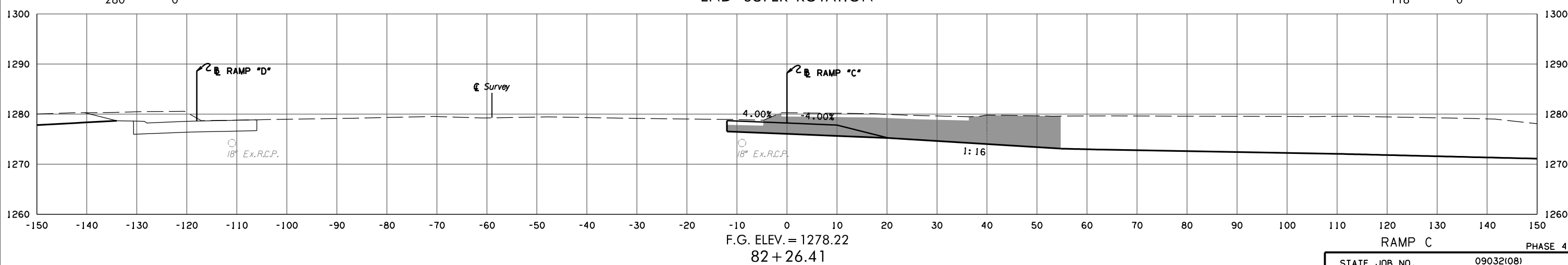
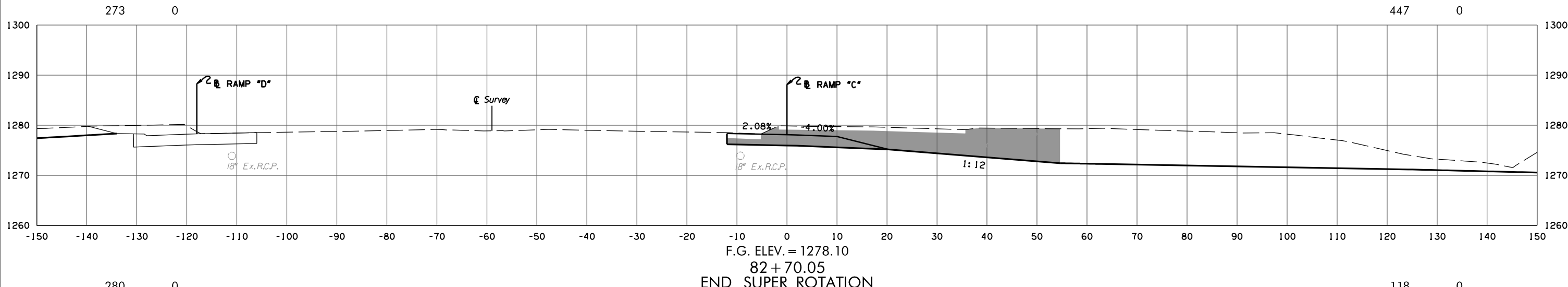
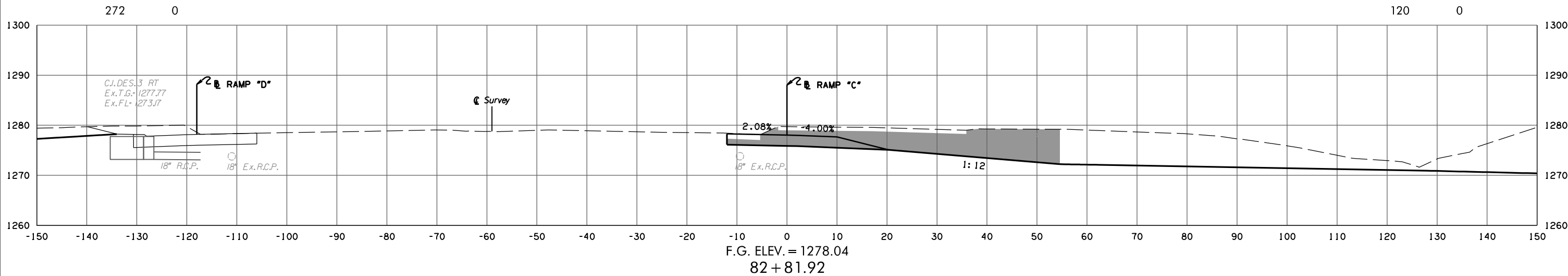

3/4/2024 3:57:59 PM H:\PROJECTS\2789_CrossRoads_Phase 4\Roadway\Drawings\Sections\0903208-XSEC_Ramp_C.dgn

(CAUTION) THE LOCATION OF ALL UTILITIES AS SHOWN ARE APPROXIMATE. DUE TO RELOCATION'S PLANNED OR PRESENTLY UNDER CONSTRUCTION THERE ARE SOME UTILITIES THAT WILL BE RELOCATED AND NOT SHOWN ON THESE PLANS. THE CONTRACTOR SHALL BE RESPONSIBLE FOR ANY DAMAGE TO ALL UTILITIES.

DEPTH & LOCATION OF EXISTING UTILITIES SHALL BE FIELD VERIFIED BY THE CONTRACTOR PRIOR TO CONSTRUCTION.

SEE DRAINAGE AREA MAP SHEETS FOR DRAINAGE SYMBOLOLOGY.

R/W & U/E PURCHASED UNDER JP 09032(05)

POB & ASSOCIATES, OKLAHOMA CITY, OK.

90% PLAN SUBMITTAL

3/4/2024

AREA
CUT FILL

VOLUME
CUT FILL

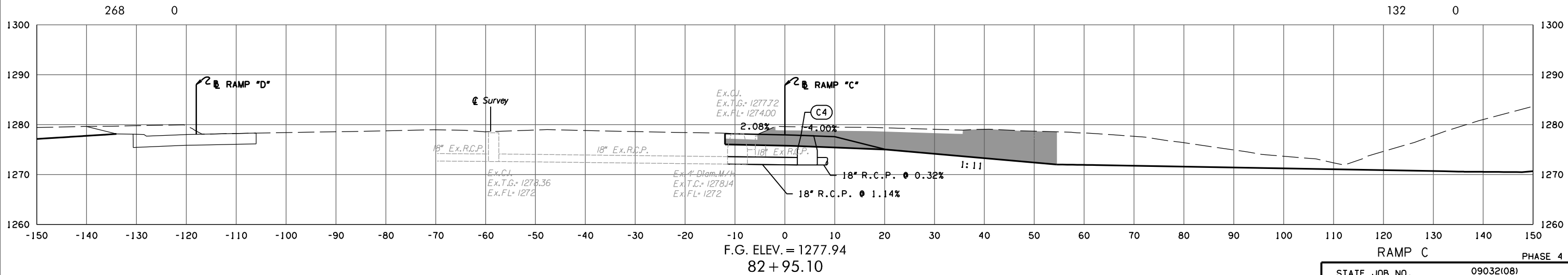
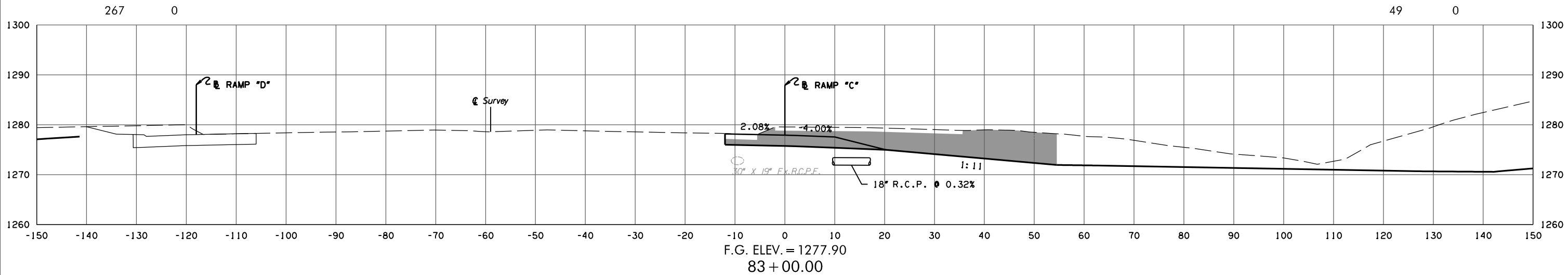
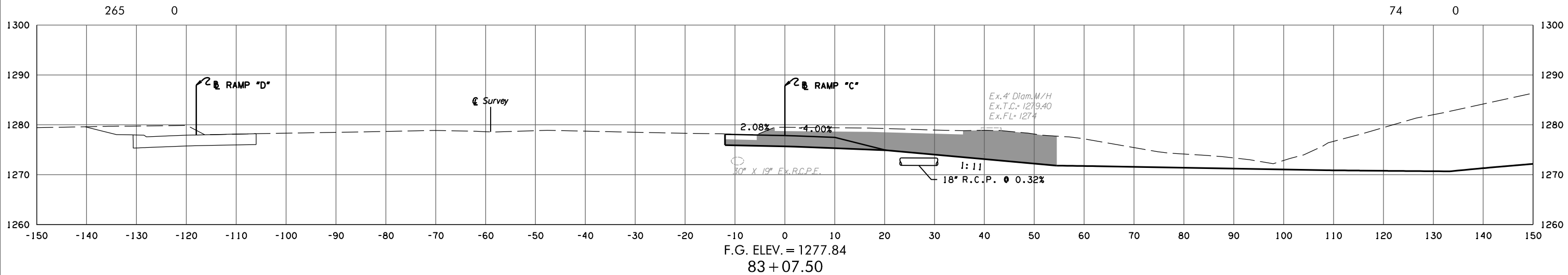

3/4/2024 3:58:00 PM H:\PROJECTS\2789_CrossRoads_Phase 4\Roadway\Drawings\Sections\0903208-XSEC_Ramp_C.dgn

(CAUTION) THE LOCATION OF ALL UTILITIES AS SHOWN ARE APPROXIMATE. DUE TO RELOCATION'S PLANNED OR PRESENTLY UNDER CONSTRUCTION THERE ARE SOME UTILITIES THAT WILL BE RELOCATED AND NOT SHOWN ON THESE PLANS. THE CONTRACTOR SHALL BE RESPONSIBLE FOR ANY DAMAGE TO ALL UTILITIES.
 DEPTH & LOCATION OF EXISTING UTILITIES SHALL BE FIELD VERIFIED BY THE CONTRACTOR PRIOR TO CONSTRUCTION.

SEE DRAINAGE AREA MAP SHEETS FOR DRAINAGE SYMBOLOLOGY.

R/W & U/E PURCHASED UNDER JP 09032(05)

POB & ASSOCIATES, OKLAHOMA CITY, OK.
90% PLAN SUBMITTAL
 3/4/2024

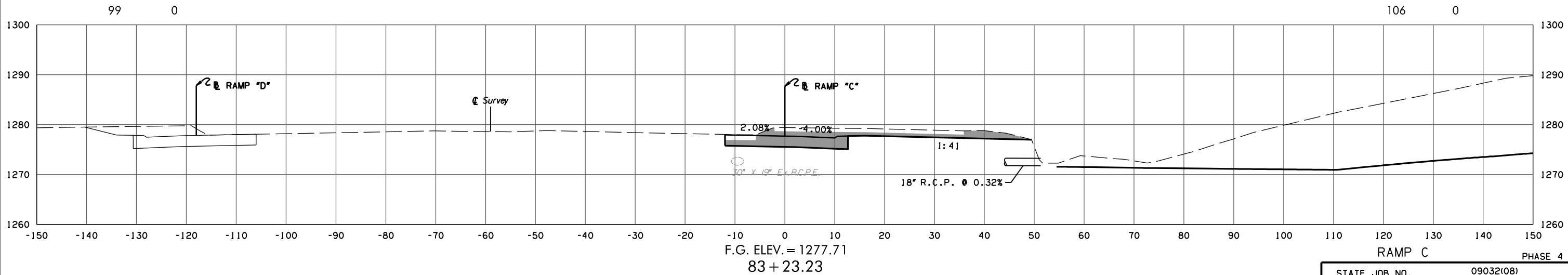
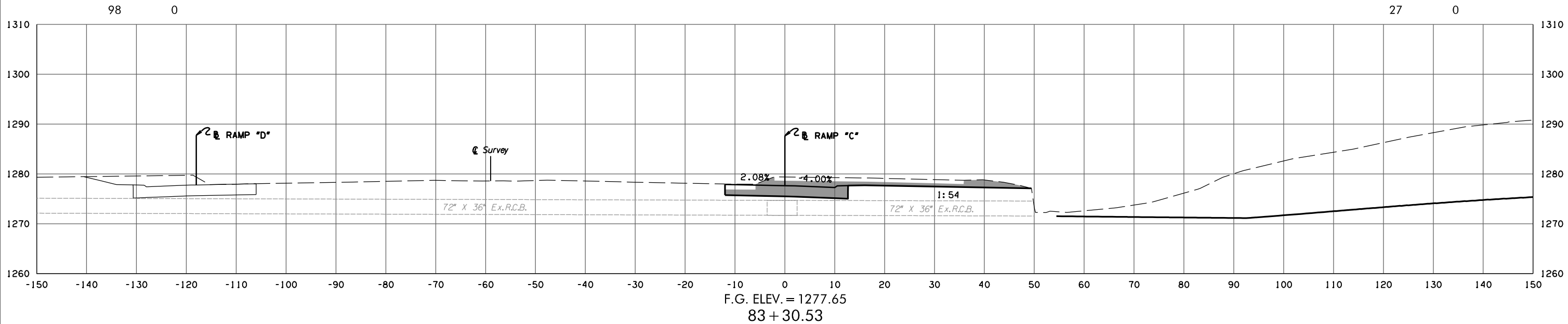
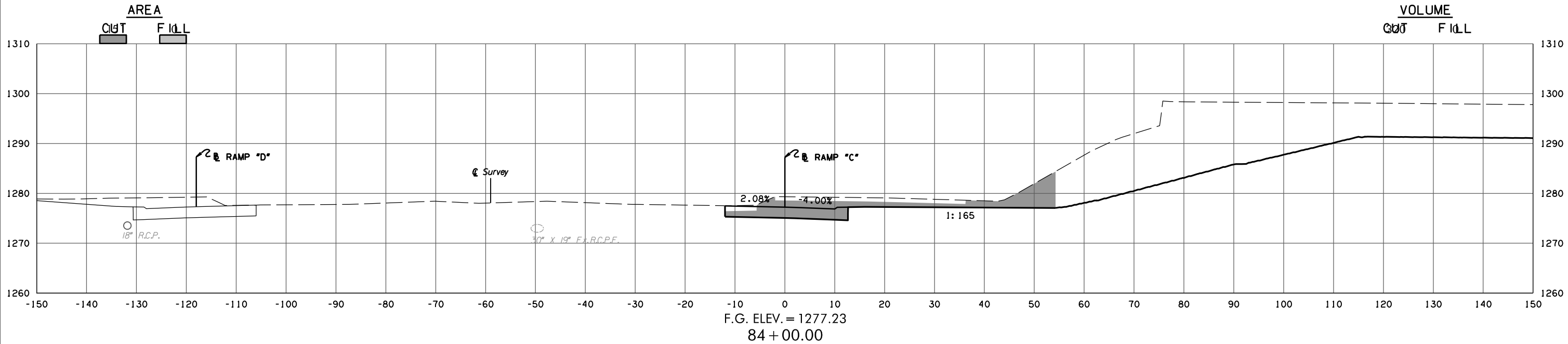

STATE JOB NO. 09032(08)
 OKLAHOMA COUNTY SHEET NO. X172

3/4/2024 3:58:01 PM H:\PROJECTS\2789_CrossRoads_Phase 4\Roadway\Drawings\Sections\0903208-XSEC_Ramp_C.dgn

(CAUTION) THE LOCATION OF ALL UTILITIES AS SHOWN ARE APPROXIMATE. DUE TO RELOCATION'S PLANNED OR PRESENTLY UNDER CONSTRUCTION THERE ARE SOME UTILITIES THAT WILL BE RELOCATED AND NOT SHOWN ON THESE PLANS. THE CONTRACTOR SHALL BE RESPONSIBLE FOR ANY DAMAGE TO ALL UTILITIES.

DEPTH & LOCATION OF EXISTING UTILITIES SHALL BE FIELD VERIFIED BY THE CONTRACTOR PRIOR TO CONSTRUCTION.

SEE DRAINAGE AREA MAP SHEETS FOR DRAINAGE SYMBOLOLOGY.

R/W & U/E PURCHASED UNDER JP 09032(05)

POB & ASSOCIATES, OKLAHOMA CITY, OK.

**90% PLAN
SUBMITTAL**

3/4/2024

AREA
CUT FILL

VOLUME
CUT FILL

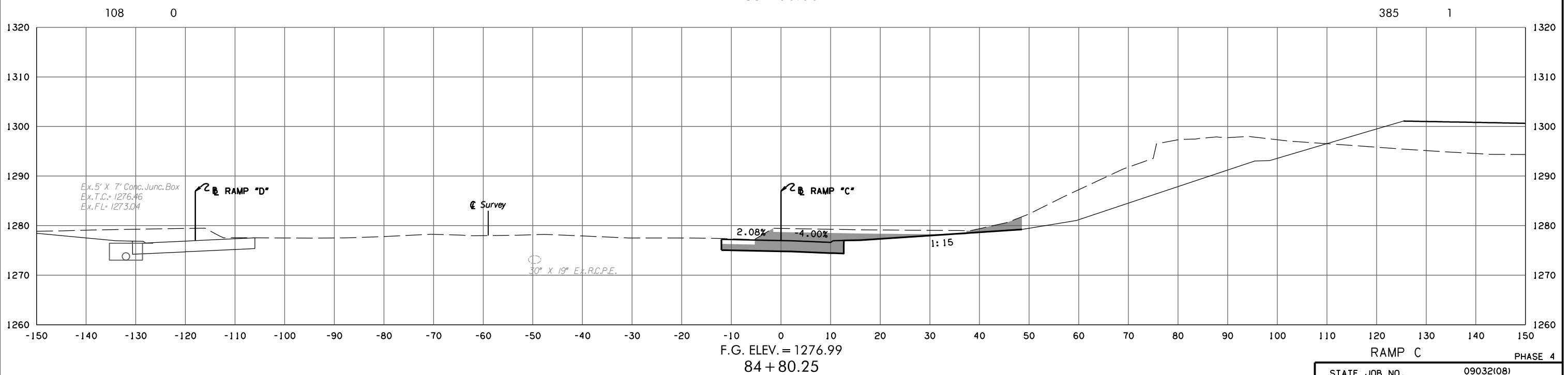
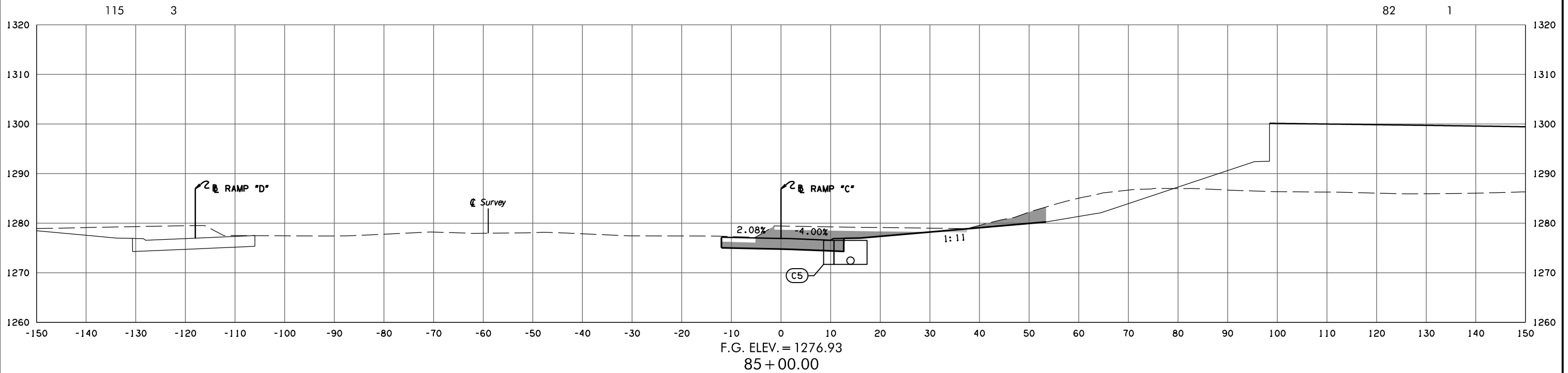

RAMP C PHASE 4

STATE JOB NO. 09032(08)
OKLAHOMA COUNTY SHEET NO. X173

3/4/2024 3:58:02 PM H:\PROJECTS\2789_CrossRoads_Phase 4\Roadway\Drawings\Sections\0903208-XSEC_Ramp_C.dgn

(CAUTION) THE LOCATION OF ALL UTILITIES AS SHOWN ARE APPROXIMATE. DUE TO RELOCATION'S PLANNED OR PRESENTLY UNDER CONSTRUCTION THERE ARE SOME UTILITIES THAT WILL BE RELOCATED AND NOT SHOWN ON THESE PLANS. THE CONTRACTOR SHALL BE RESPONSIBLE FOR ANY DAMAGE TO ALL UTILITIES.

DEPTH & LOCATION OF EXISTING UTILITIES SHALL BE FIELD VERIFIED BY THE CONTRACTOR PRIOR TO CONSTRUCTION.

SEE DRAINAGE AREA MAP SHEETS FOR DRAINAGE SYMBOLOLOGY.

R/W & U/E PURCHASED UNDER JP 09032(05)

POB & ASSOCIATES, OKLAHOMA CITY, OK.

**90% PLAN
SUBMITTAL**

3/4/2024

AREA
CUT FILL

VOLUME
CUT FILL

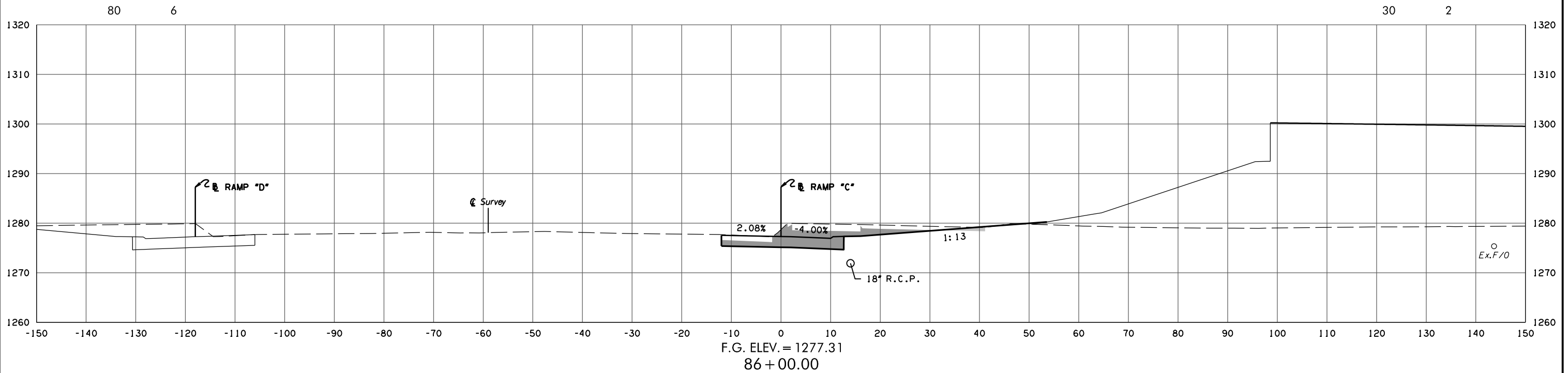

F.G. ELEV. = 1277.31
86+00.00

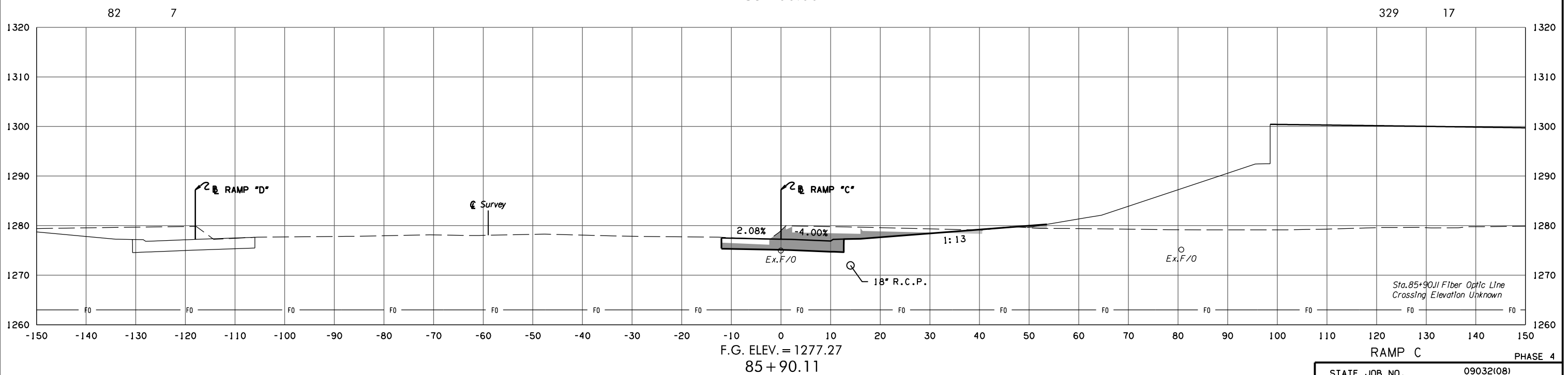

F.G. ELEV. = 1277.27
85+90.11

RAMP C PHASE 4

STATE JOB NO. 09032(08)
OKLAHOMA COUNTY SHEET NO. X174

3/4/2024 3:58:02 PM H:\PROJECTS\2789_CrossRoads_Phase 4\Roadway\Drawings\Sections\0903208-XSEC_Ramp_C.dgn

(CAUTION) THE LOCATION OF ALL UTILITIES AS SHOWN ARE APPROXIMATE. DUE TO RELOCATION'S PLANNED OR PRESENTLY UNDER CONSTRUCTION THERE ARE SOME UTILITIES THAT WILL BE RELOCATED AND NOT SHOWN ON THESE PLANS. THE CONTRACTOR SHALL BE RESPONSIBLE FOR ANY DAMAGE TO ALL UTILITIES.
 DEPTH & LOCATION OF EXISTING UTILITIES SHALL BE FIELD VERIFIED BY THE CONTRACTOR PRIOR TO CONSTRUCTION.

SEE DRAINAGE AREA MAP SHEETS FOR DRAINAGE SYMBOLOLOGY.

R/W & U/E PURCHASED UNDER JP 09032(05)

POB & ASSOCIATES, OKLAHOMA CITY, OK.
90% PLAN SUBMITTAL
 3/4/2024

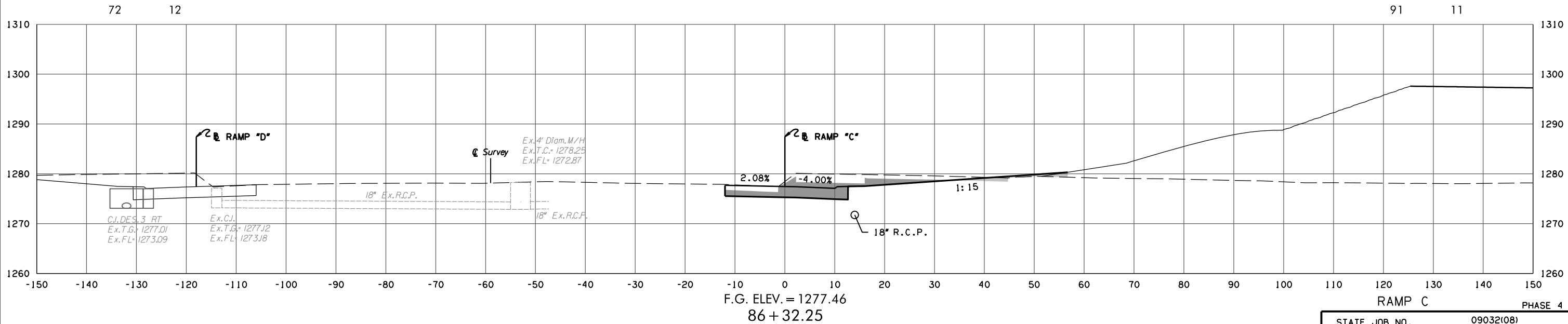
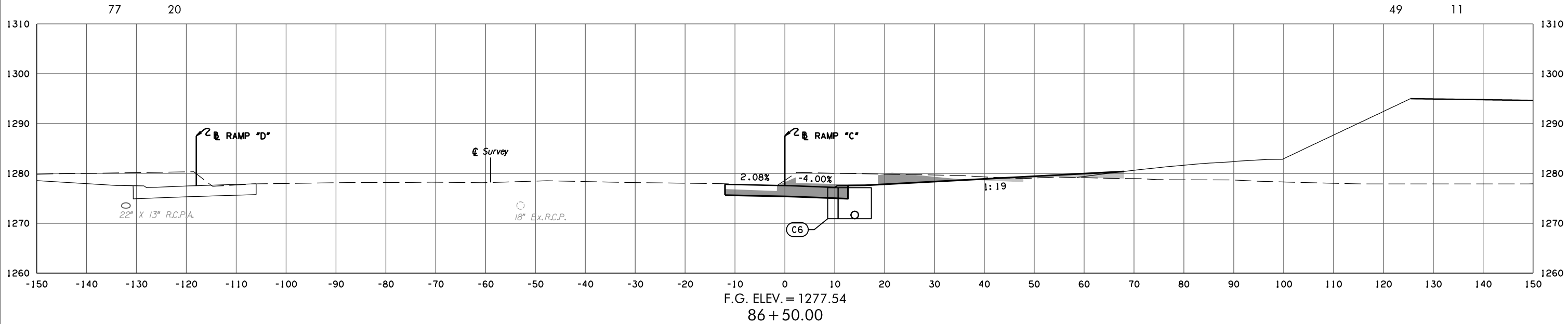
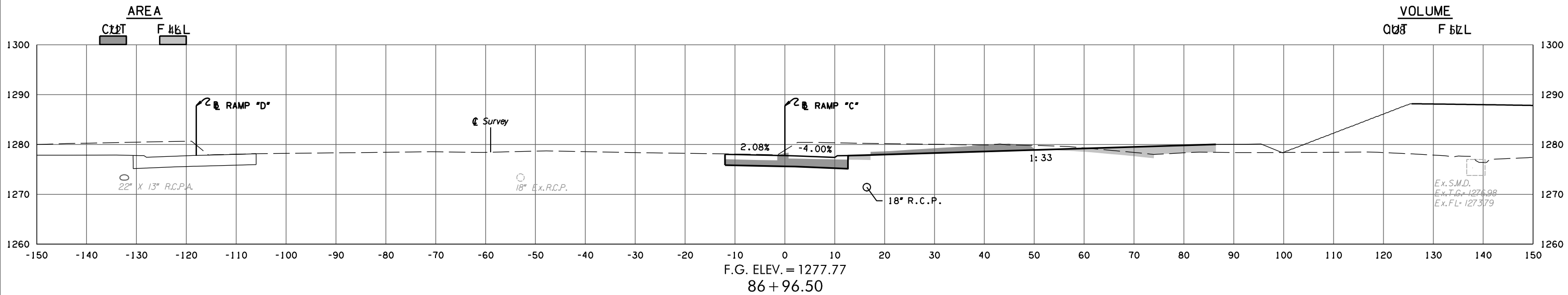

3/4/2024 3:58:03 PM H:\PROJECTS\2789_CrossRoads_Phase 4\Roadway\Drawings\Sections\0903208-XSEC-Ramp_C.dgn

RAMP C PHASE 4
 STATE JOB NO. 09032(08)
 OKLAHOMA COUNTY SHEET NO. X175

(CAUTION) THE LOCATION OF ALL UTILITIES AS SHOWN ARE APPROXIMATE. DUE TO RELOCATION'S PLANNED OR PRESENTLY UNDER CONSTRUCTION THERE ARE SOME UTILITIES THAT WILL BE RELOCATED AND NOT SHOWN ON THESE PLANS. THE CONTRACTOR SHALL BE RESPONSIBLE FOR ANY DAMAGE TO ALL UTILITIES.

SEE DRAINAGE AREA MAP SHEETS FOR DRAINAGE SYMBOLOLOGY.

R/W & U/E PURCHASED UNDER JP 09032(05)

POB & ASSOCIATES, OKLAHOMA CITY, OK.

**90% PLAN
SUBMITTAL**

3/4/2024

DEPTH & LOCATION OF EXISTING UTILITIES SHALL BE FIELD VERIFIED BY THE CONTRACTOR PRIOR TO CONSTRUCTION.

AREA
CUT FILL

VOLUME
CUT FILL

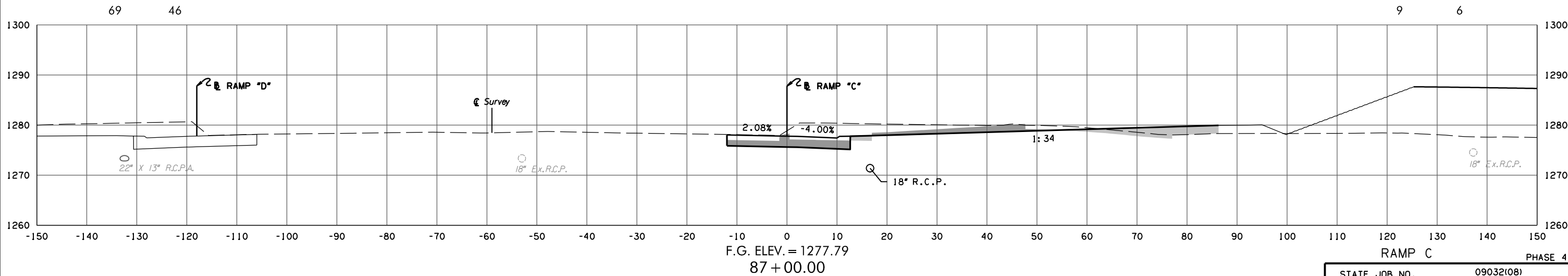
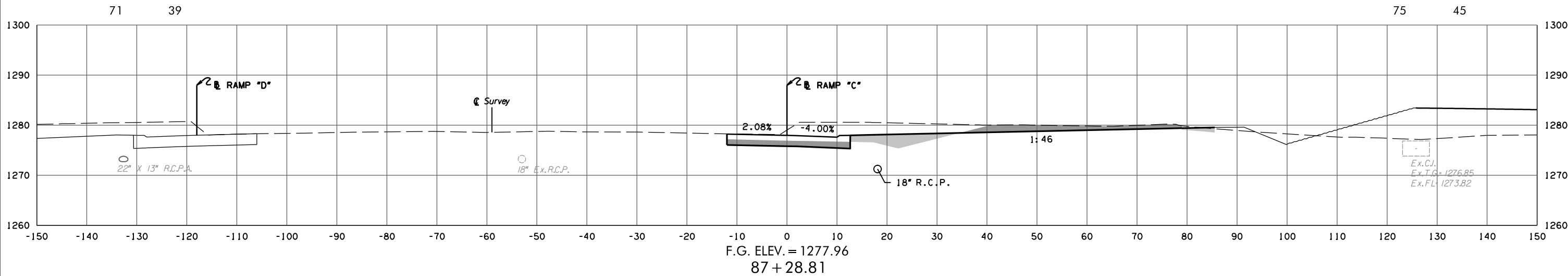
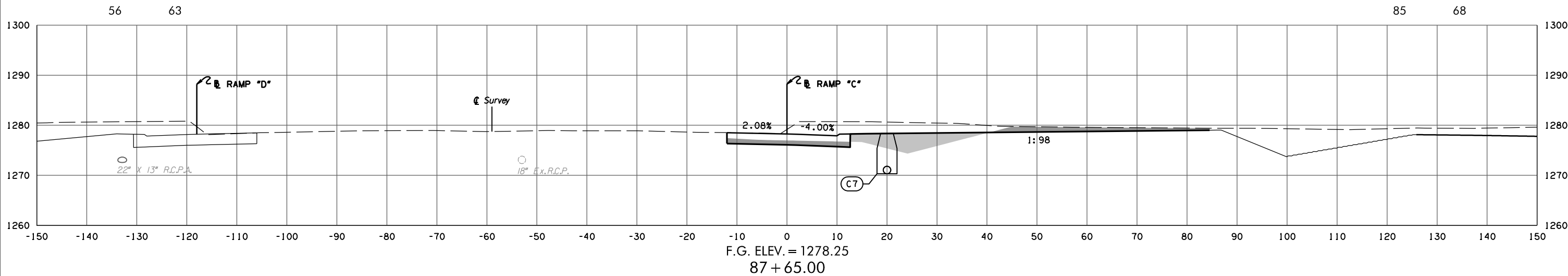

3/4/2024 3:58:04 PM H:\PROJECTS\2789_CrossRoads_Phase 4\Roadway\Drawings\Sections\0903208-XSEC_Ramp-C.dgn

(CAUTION) THE LOCATION OF ALL UTILITIES AS SHOWN ARE APPROXIMATE. DUE TO RELOCATION'S PLANNED OR PRESENTLY UNDER CONSTRUCTION THERE ARE SOME UTILITIES THAT WILL BE RELOCATED AND NOT SHOWN ON THESE PLANS. THE CONTRACTOR SHALL BE RESPONSIBLE FOR ANY DAMAGE TO ALL UTILITIES.

SEE DRAINAGE AREA MAP SHEETS FOR DRAINAGE SYMBOLLOGY.

R/W & U/E PURCHASED UNDER JP 09032(05)

POB & ASSOCIATES, OKLAHOMA CITY, OK.

**90% PLAN
SUBMITTAL**

3/4/2024

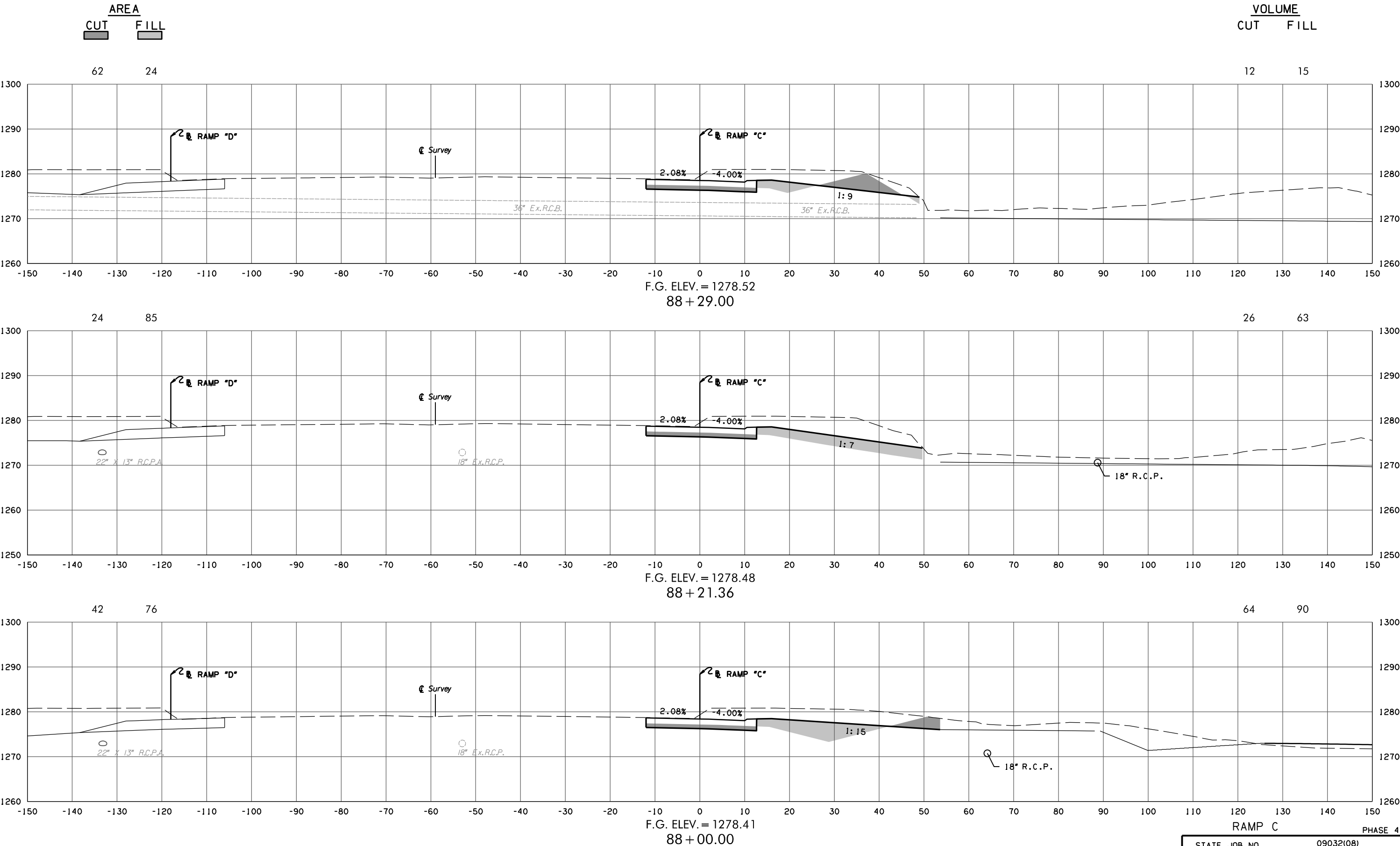

3/4/2024 3:58:05 PM H:\PROJECTS\2789_CrossRoads_Phase 4\Roadway\Drawings\Sections\0903208-XSEC_Ramp_C.dgn

(CAUTION) THE LOCATION OF ALL UTILITIES AS SHOWN ARE APPROXIMATE. DUE TO RELOCATION'S PLANNED OR PRESENTLY UNDER CONSTRUCTION THERE ARE SOME UTILITIES THAT WILL BE RELOCATED AND NOT SHOWN ON THESE PLANS. THE CONTRACTOR SHALL BE RESPONSIBLE FOR ANY DAMAGE TO ALL UTILITIES. DEPTH & LOCATION OF EXISTING UTILITIES SHALL BE FIELD VERIFIED BY THE CONTRACTOR PRIOR TO CONSTRUCTION.

SEE DRAINAGE AREA MAP SHEETS FOR DRAINAGE SYMBOLOLOGY.

R/W & U/E PURCHASED UNDER JP 09032(05)

POB & ASSOCIATES, OKLAHOMA CITY, OK.
90% PLAN
SUBMITTAL
 3/4/2024

AREA
 CUT FILL

VOLUME
 CUT FILL

3/4/2024 3:58:05 PM H:\PROJECTS\21789_CrossRoads_Phase 4\Roadway\Drawings\Sections\0903208-XSEC_Ramp_C.dgn

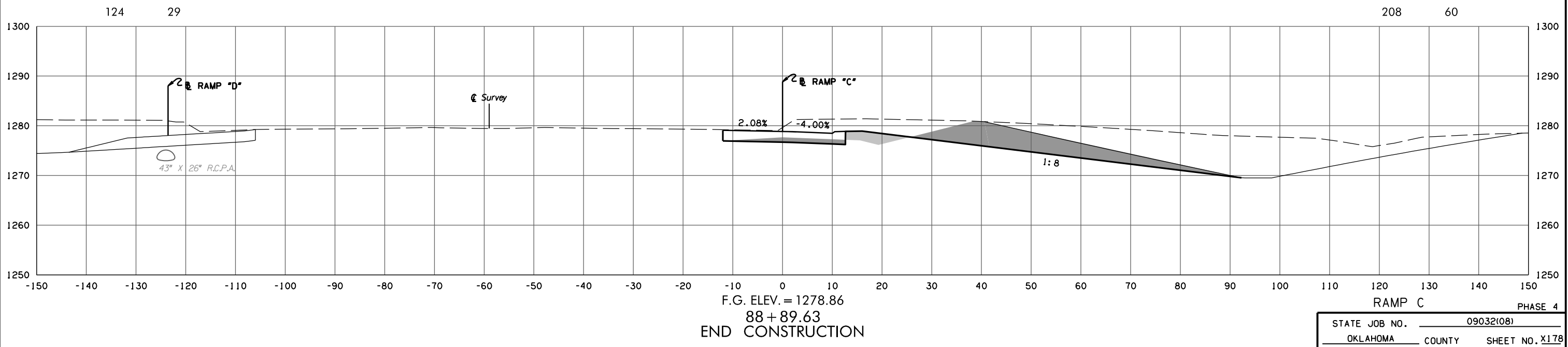

STATE JOB NO. 09032(08)
 OKLAHOMA COUNTY SHEET NO. X178

(CAUTION) THE LOCATION OF ALL UTILITIES AS SHOWN ARE APPROXIMATE. DUE TO RELOCATION'S PLANNED OR PRESENTLY UNDER CONSTRUCTION THERE ARE SOME UTILITIES THAT WILL BE RELOCATED AND NOT SHOWN ON THESE PLANS. THE CONTRACTOR SHALL BE RESPONSIBLE FOR ANY DAMAGE TO ALL UTILITIES.

DEPTH & LOCATION OF EXISTING UTILITIES SHALL BE FIELD VERIFIED BY THE CONTRACTOR PRIOR TO CONSTRUCTION.

SEE DRAINAGE AREA MAP SHEETS FOR DRAINAGE SYMBOLOLOGY.

R/W & U/E PURCHASED UNDER JP 09032(05)

POB & ASSOCIATES, OKLAHOMA CITY, OK.

**90% PLAN
SUBMITTAL**

3/4/2024

AREA
CUT FILL

VOLUME
CUT FILL

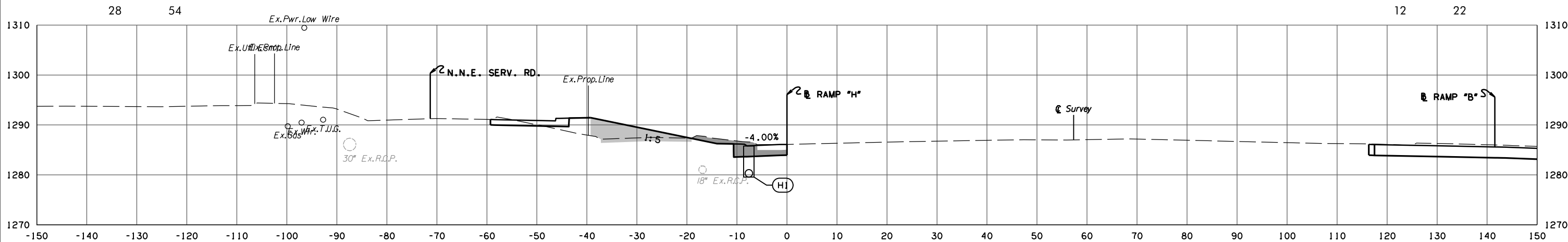

F.G. ELEV. = 1286.11
414+55.00
BEGIN CONSTRUCTION

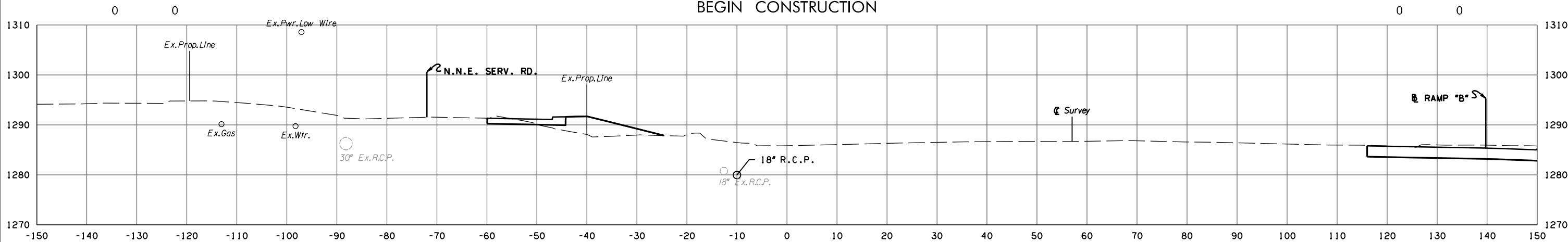

414+32.34

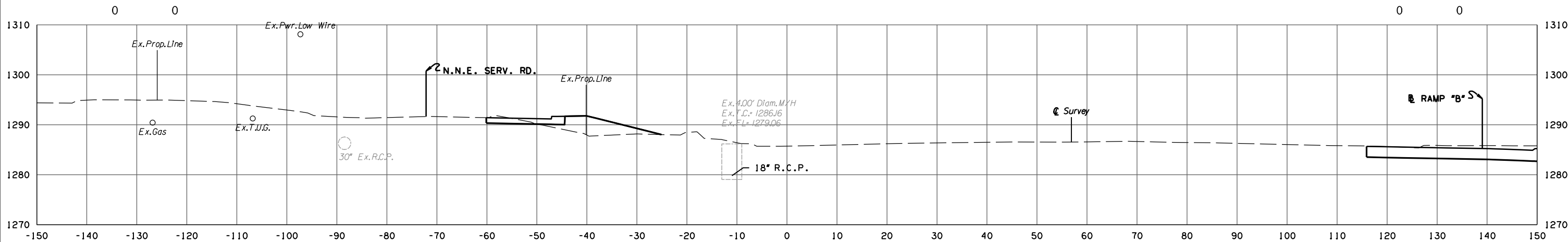

414+23.71

RAMP H PHASE 4

STATE JOB NO. 09032(08)
OKLAHOMA COUNTY SHEET NO. X179

3/4/2024 3:58:07 PM H:\PROJECTS\2789_CrossRoads_Phase 4 Roadway\Drawings\Sections\0903208-XSEC_Ramp_H.dgn

(CAUTION) THE LOCATION OF ALL UTILITIES AS SHOWN ARE APPROXIMATE. DUE TO RELOCATION'S PLANNED OR PRESENTLY UNDER CONSTRUCTION THERE ARE SOME UTILITIES THAT WILL BE RELOCATED AND NOT SHOWN ON THESE PLANS. THE CONTRACTOR SHALL BE RESPONSIBLE FOR ANY DAMAGE TO ALL UTILITIES.

DEPTH & LOCATION OF EXISTING UTILITIES SHALL BE FIELD VERIFIED BY THE CONTRACTOR PRIOR TO CONSTRUCTION.

SEE DRAINAGE AREA MAP SHEETS FOR DRAINAGE SYMBOLOLOGY.

R/W & U/E PURCHASED UNDER JP 09032(05)

POE & ASSOCIATES, OKLAHOMA CITY, OK.

**90% PLAN
SUBMITTAL**

3/4/2024

AREA
CUT FILL

VOLUME
CUT FILL

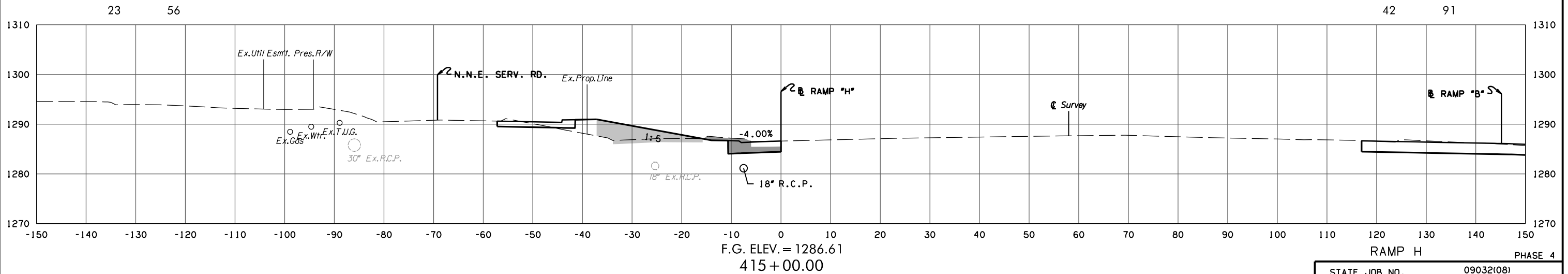
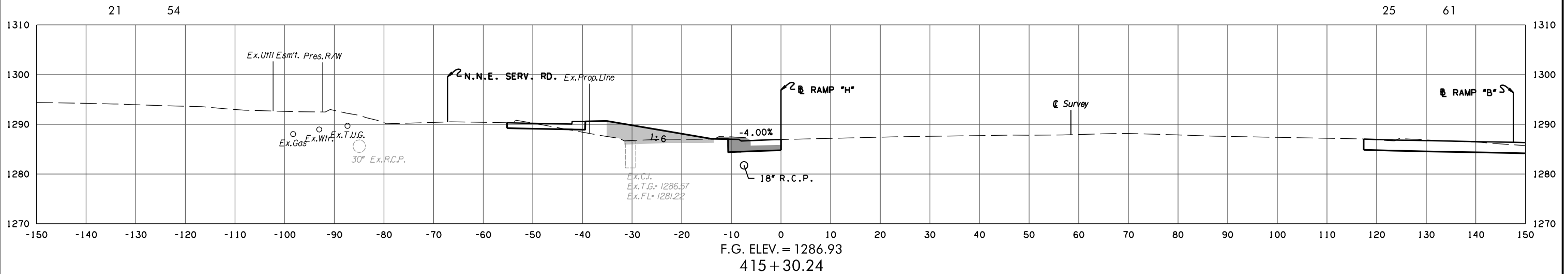
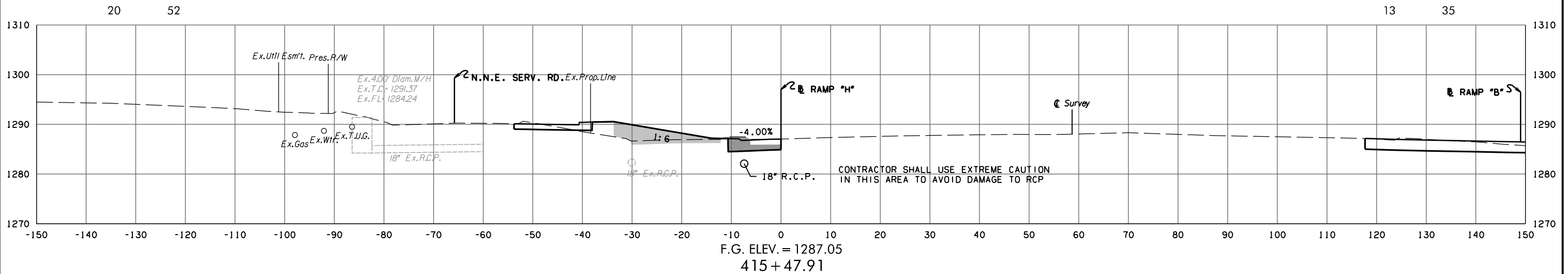

3/4/2024 3:58:08 PM H:\PROJECTS\2789_CrossRoads_Phase 4\Roadway\Drawings\Sections\0903208-XSEC_Ramp_H.dgn

(CAUTION) THE LOCATION OF ALL UTILITIES AS SHOWN ARE APPROXIMATE. DUE TO RELOCATION'S PLANNED OR PRESENTLY UNDER CONSTRUCTION THERE ARE SOME UTILITIES THAT WILL BE RELOCATED AND NOT SHOWN ON THESE PLANS. THE CONTRACTOR SHALL BE RESPONSIBLE FOR ANY DAMAGE TO ALL UTILITIES.

DEPTH & LOCATION OF EXISTING UTILITIES SHALL BE FIELD VERIFIED BY THE CONTRACTOR PRIOR TO CONSTRUCTION.

SEE DRAINAGE AREA MAP SHEETS FOR DRAINAGE SYMBOLOLOGY.

R/W & U/E PURCHASED UNDER JP 09032(05)

POB & ASSOCIATES, OKLAHOMA CITY, OK.

**90% PLAN
SUBMITTAL**

3/4/2024

AREA
CUT FILL

VOLUME
CUT FILL

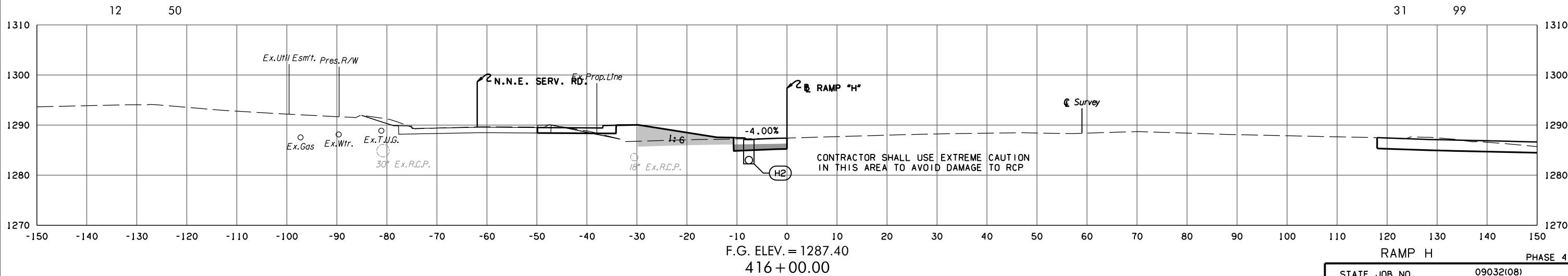
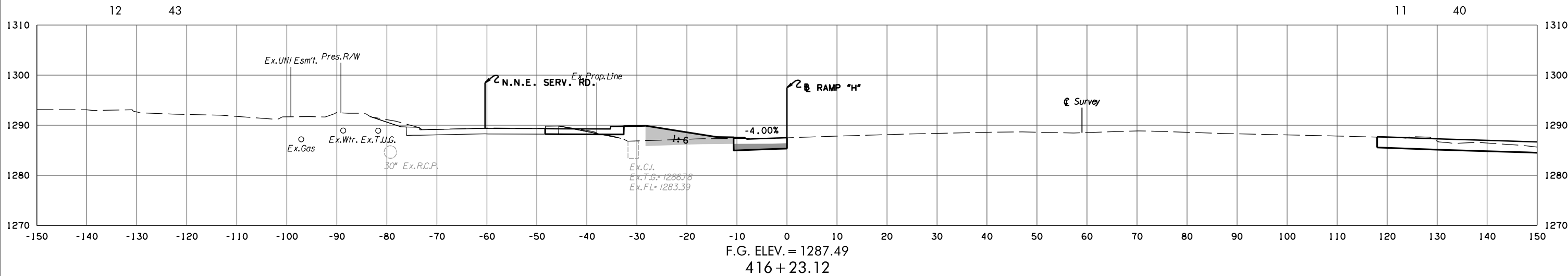
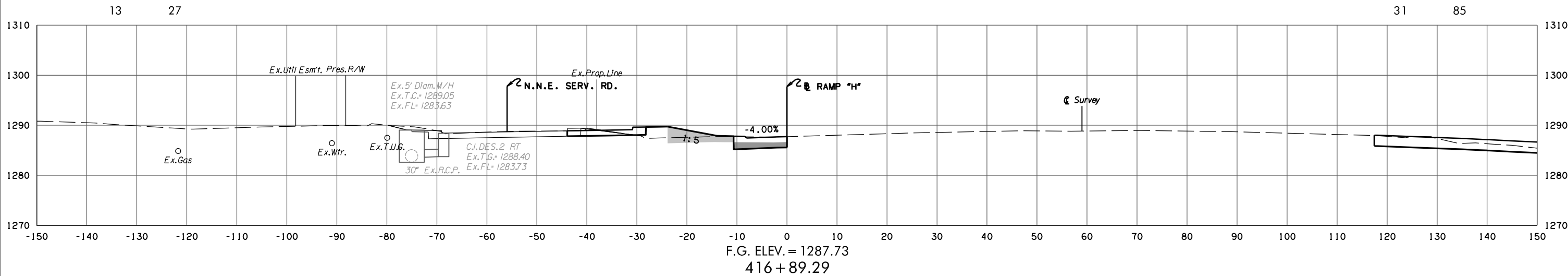

CONTRACTOR SHALL USE EXTREME CAUTION IN THIS AREA TO AVOID DAMAGE TO RCP

3/4/2024 3:58:09 PM H:\PROJECTS\2789_CrossRoads_Phase 4\Roadway\Drawings\Sections\0903208-XSEC_Ramp_H.dgn

(CAUTION) THE LOCATION OF ALL UTILITIES AS SHOWN ARE APPROXIMATE. DUE TO RELOCATION'S PLANNED OR PRESENTLY UNDER CONSTRUCTION THERE ARE SOME UTILITIES THAT WILL BE RELOCATED AND NOT SHOWN ON THESE PLANS. THE CONTRACTOR SHALL BE RESPONSIBLE FOR ANY DAMAGE TO ALL UTILITIES. DEPTH & LOCATION OF EXISTING UTILITIES SHALL BE FIELD VERIFIED BY THE CONTRACTOR PRIOR TO CONSTRUCTION.

SEE DRAINAGE AREA MAP SHEETS FOR DRAINAGE SYMBOLOLOGY.

R/W & U/E PURCHASED UNDER JP 09032(05)

POB & ASSOCIATES, OKLAHOMA CITY, OK.

90% PLAN SUBMITTAL

3/4/2024

AREA
CUT FILL

VOLUME
CUT FILL

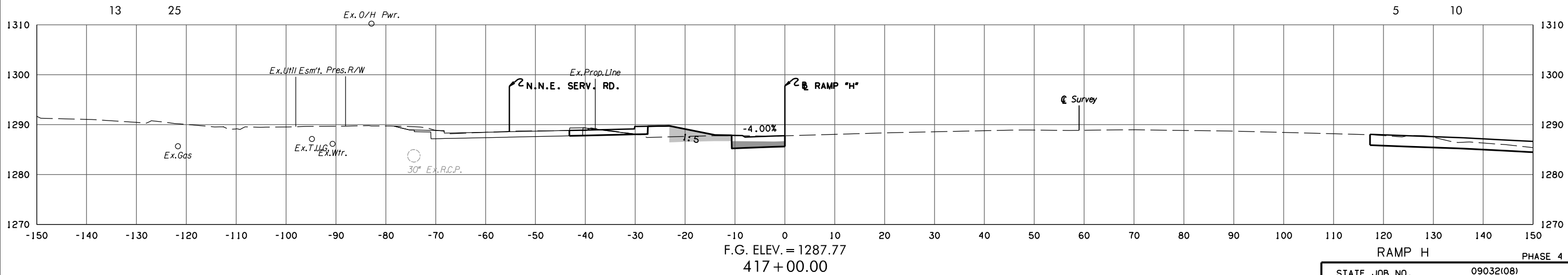
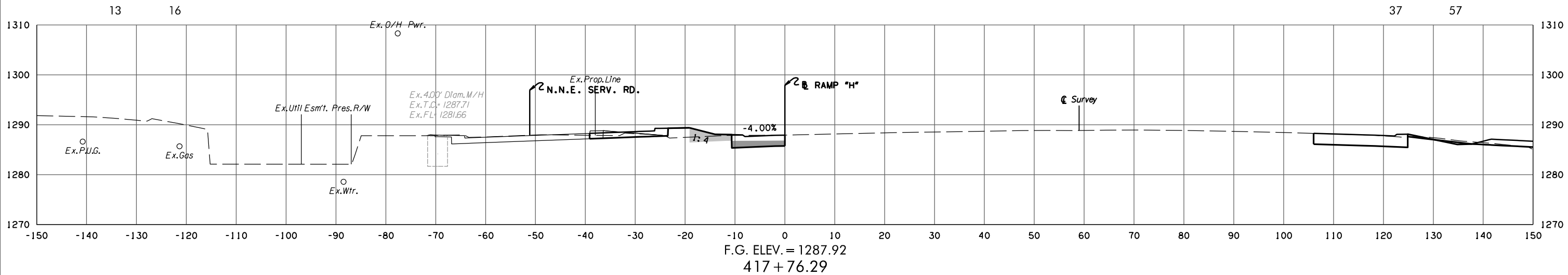
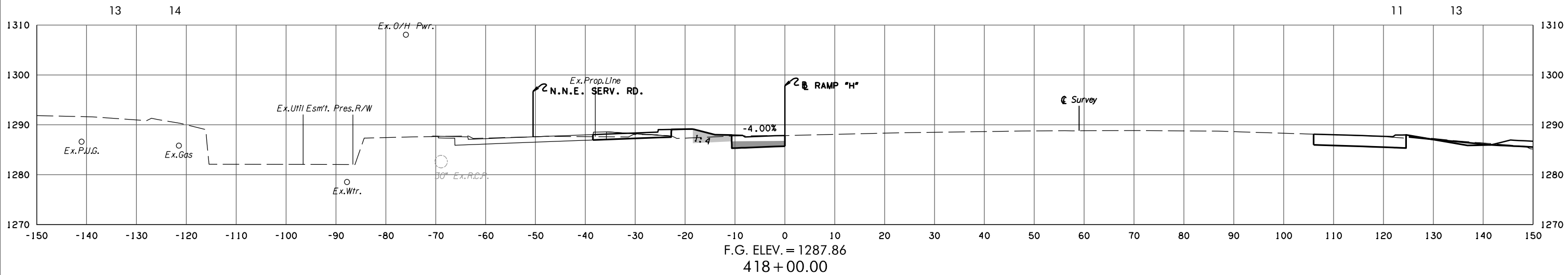

3/4/2024 3:58:10 PM H:\PROJECTS\2789_CrossRoads_Phase 4\Roadway\Drawings\Sections\0903208-XSEC_Ramp_H.dgn

(CAUTION) THE LOCATION OF ALL UTILITIES AS SHOWN ARE APPROXIMATE. DUE TO RELOCATION'S PLANNED OR PRESENTLY UNDER CONSTRUCTION THERE ARE SOME UTILITIES THAT WILL BE RELOCATED AND NOT SHOWN ON THESE PLANS. THE CONTRACTOR SHALL BE RESPONSIBLE FOR ANY DAMAGE TO ALL UTILITIES.
 DEPTH & LOCATION OF EXISTING UTILITIES SHALL BE FIELD VERIFIED BY THE CONTRACTOR PRIOR TO CONSTRUCTION.

SEE DRAINAGE AREA MAP SHEETS FOR DRAINAGE SYMBOLOLOGY.

R/W & U/E PURCHASED UNDER JP 09032(05)

POB & ASSOCIATES, OKLAHOMA CITY, OK.
90% PLAN SUBMITTAL
 3/4/2024

AREA
 CUT FILL

VOLUME
 CUT FILL

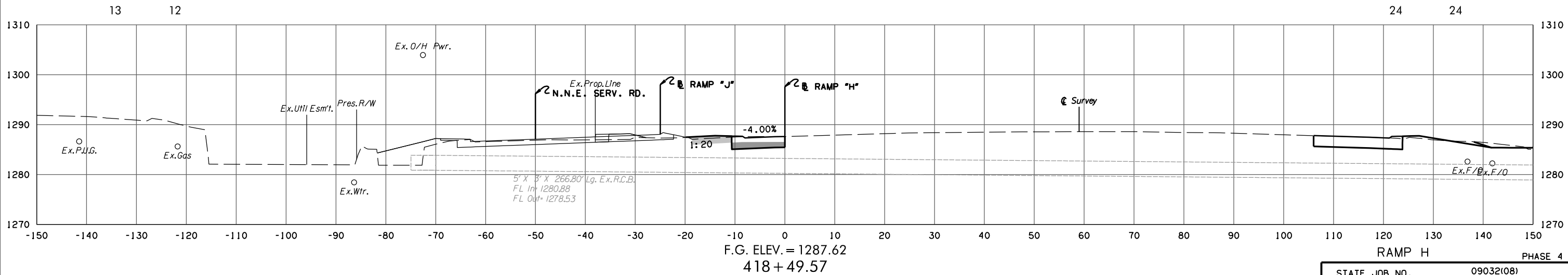
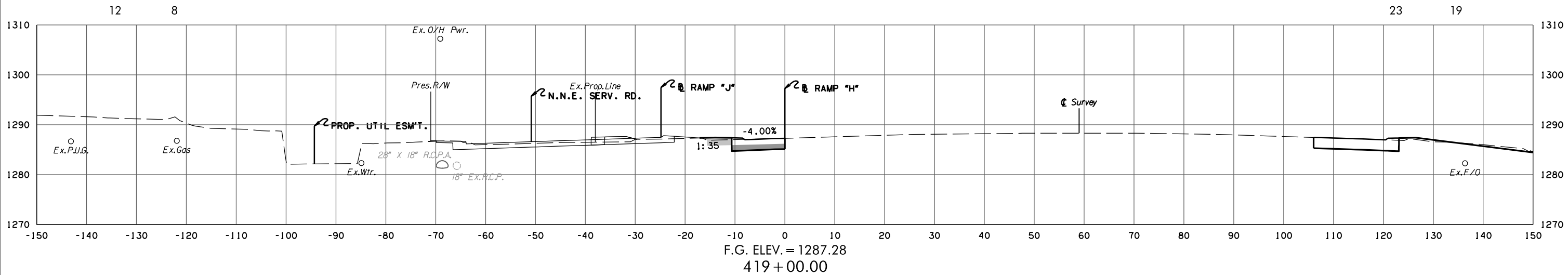
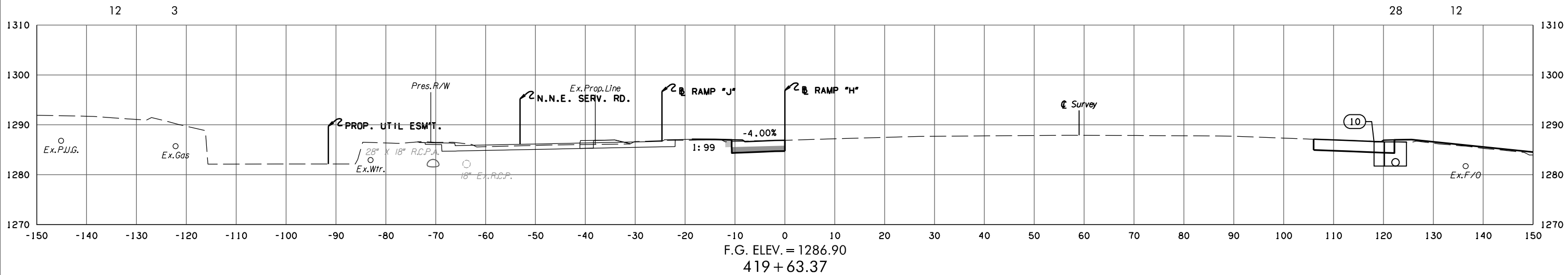

3/4/2024 3:58:11 PM H:\PROJECTS\2789_Crossroads_Phase 4\Roadway\Drawings\Sections\0903208-XSEC_Ramp_H.dgn

STATE JOB NO. 09032(08)
 OKLAHOMA COUNTY SHEET NO. X183

(CAUTION) THE LOCATION OF ALL UTILITIES AS SHOWN ARE APPROXIMATE. DUE TO RELOCATION'S PLANNED OR PRESENTLY UNDER CONSTRUCTION THERE ARE SOME UTILITIES THAT WILL BE RELOCATED AND NOT SHOWN ON THESE PLANS. THE CONTRACTOR SHALL BE RESPONSIBLE FOR ANY DAMAGE TO ALL UTILITIES.

DEPTH & LOCATION OF EXISTING UTILITIES SHALL BE FIELD VERIFIED BY THE CONTRACTOR PRIOR TO CONSTRUCTION.

SEE DRAINAGE AREA MAP SHEETS FOR DRAINAGE SYMBOLOLOGY.

R/W & U/E PURCHASED UNDER JP 09032(05)

POB & ASSOCIATES, OKLAHOMA CITY, OK.

**90% PLAN
SUBMITTAL**

3/4/2024

AREA
CUT FILL

VOLUME
CUT FILL

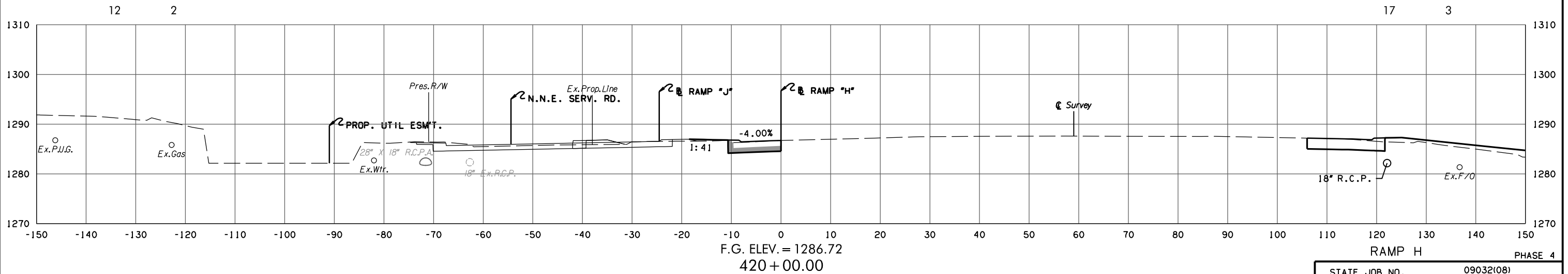
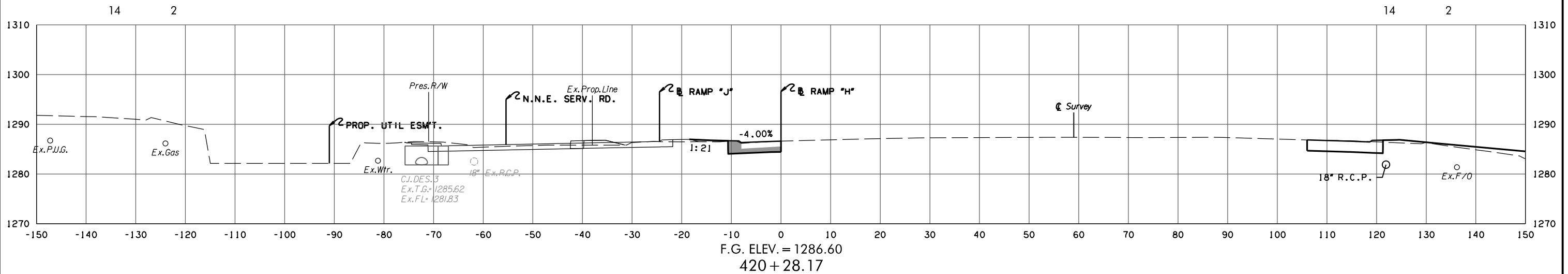
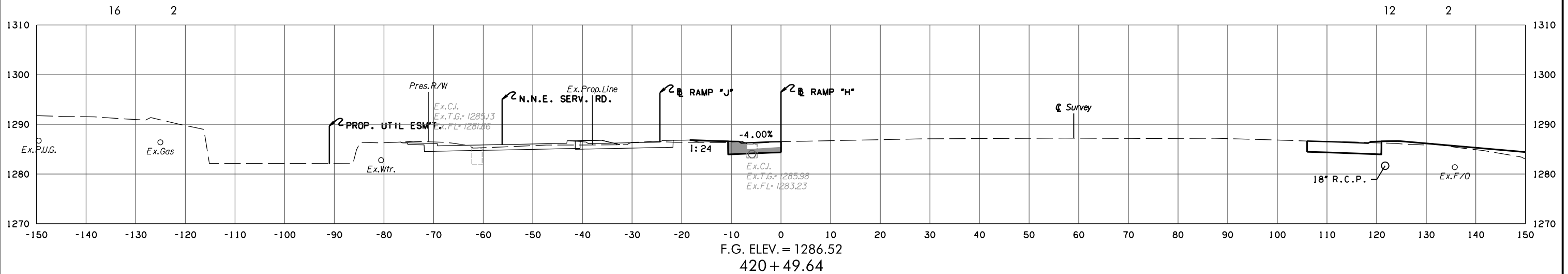

3/4/2024 3:58:42 PM H:\PROJECTS\2789_CrossRoads_Phase 4\Roadway\Drawings\Sections\0903208-XSEC_Ramp_H.dgn

STATE JOB NO. 09032(08)
OKLAHOMA COUNTY SHEET NO. X184

(CAUTION) THE LOCATION OF ALL UTILITIES AS SHOWN ARE APPROXIMATE. DUE TO RELOCATION'S PLANNED OR PRESENTLY UNDER CONSTRUCTION THERE ARE SOME UTILITIES THAT WILL BE RELOCATED AND NOT SHOWN ON THESE PLANS. THE CONTRACTOR SHALL BE RESPONSIBLE FOR ANY DAMAGE TO ALL UTILITIES.

DEPTH & LOCATION OF EXISTING UTILITIES SHALL BE FIELD VERIFIED BY THE CONTRACTOR PRIOR TO CONSTRUCTION.

SEE DRAINAGE AREA MAP SHEETS FOR DRAINAGE SYMBOLOLOGY.

R/W & U/E PURCHASED UNDER JP 09032(05)

POB & ASSOCIATES, OKLAHOMA CITY, OK.

**90% PLAN
SUBMITTAL**

3/4/2024

AREA
CUT FILL

VOLUME
CUT FILL

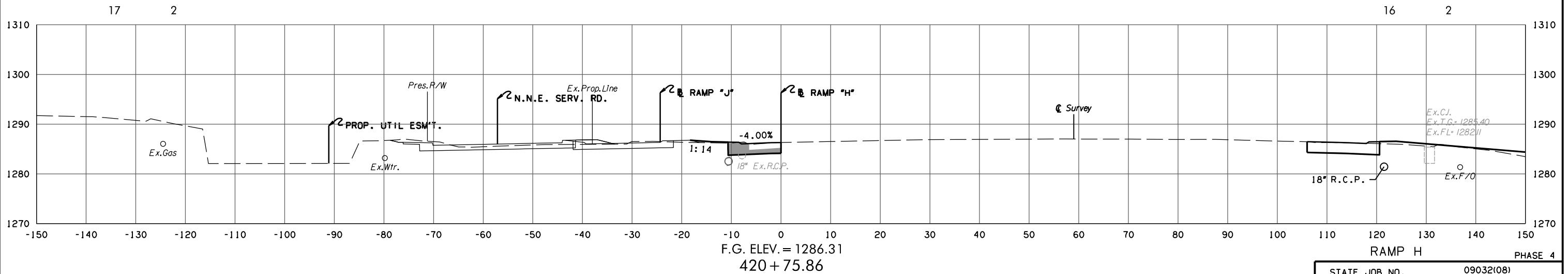
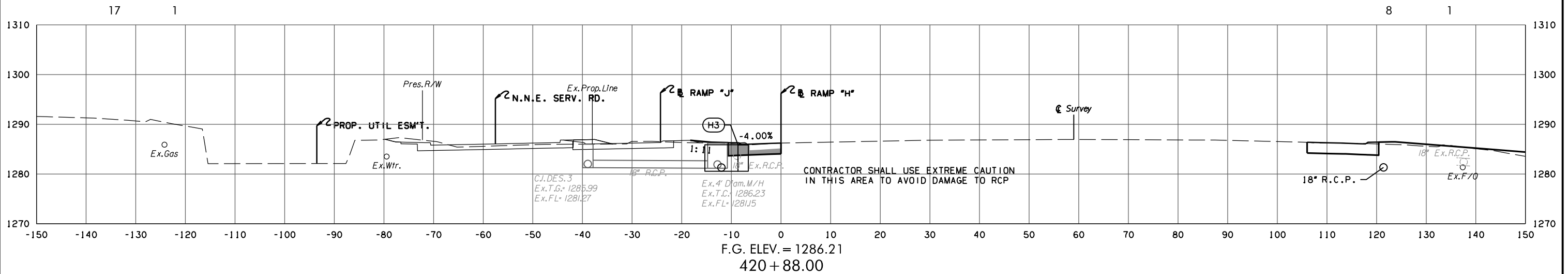
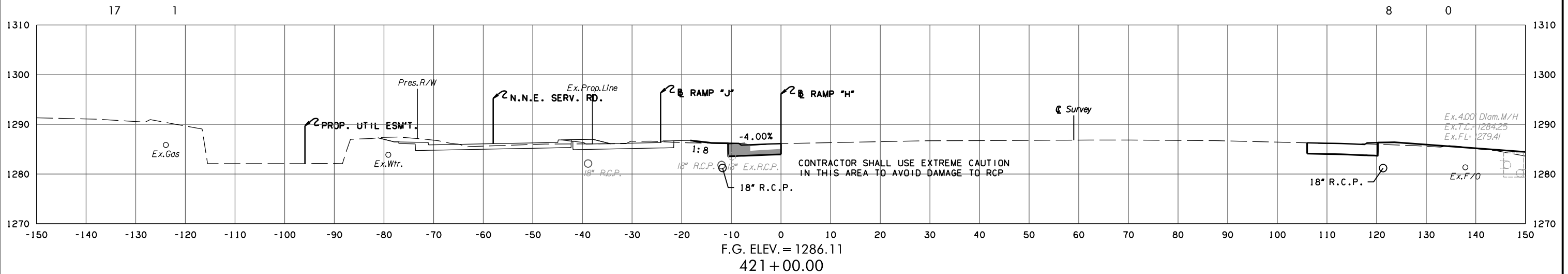

RAMP H PHASE 4

STATE JOB NO. 09032(08)

OKLAHOMA COUNTY SHEET NO. X185

3/4/2024 3:58:14 PM H:\PROJECTS\2785_CrossRoads_Phase 4\Roadway\Drawings\Sections\0903208-XSEC_Ramp_H.dgn

(CAUTION) THE LOCATION OF ALL UTILITIES AS SHOWN ARE APPROXIMATE. DUE TO RELOCATION'S PLANNED OR PRESENTLY UNDER CONSTRUCTION THERE ARE SOME UTILITIES THAT WILL BE RELOCATED AND NOT SHOWN ON THESE PLANS. THE CONTRACTOR SHALL BE RESPONSIBLE FOR ANY DAMAGE TO ALL UTILITIES.

DEPTH & LOCATION OF EXISTING UTILITIES SHALL BE FIELD VERIFIED BY THE CONTRACTOR PRIOR TO CONSTRUCTION.

SEE DRAINAGE AREA MAP SHEETS FOR DRAINAGE SYMBOLOLOGY.

R/W & U/E PURCHASED UNDER JP 09032(05)

POE & ASSOCIATES, OKLAHOMA CITY, OK.

**90% PLAN
SUBMITTAL**

3/4/2024

AREA
CUT FILL

VOLUME
CUT FILL

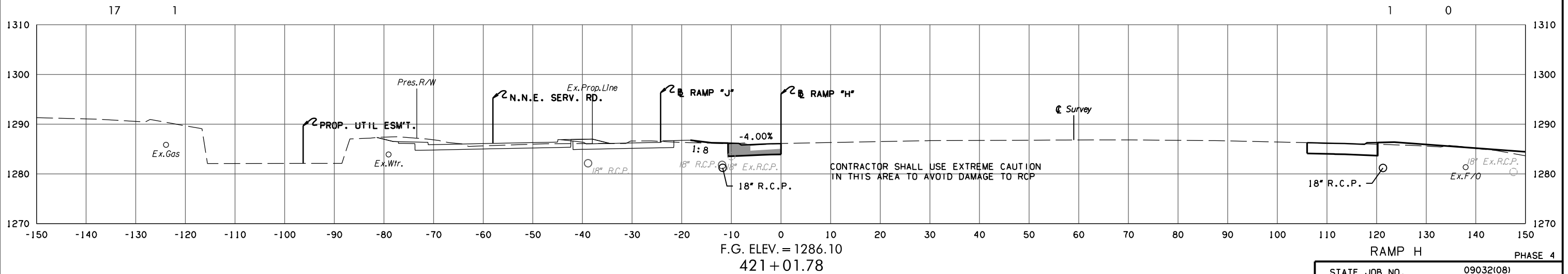
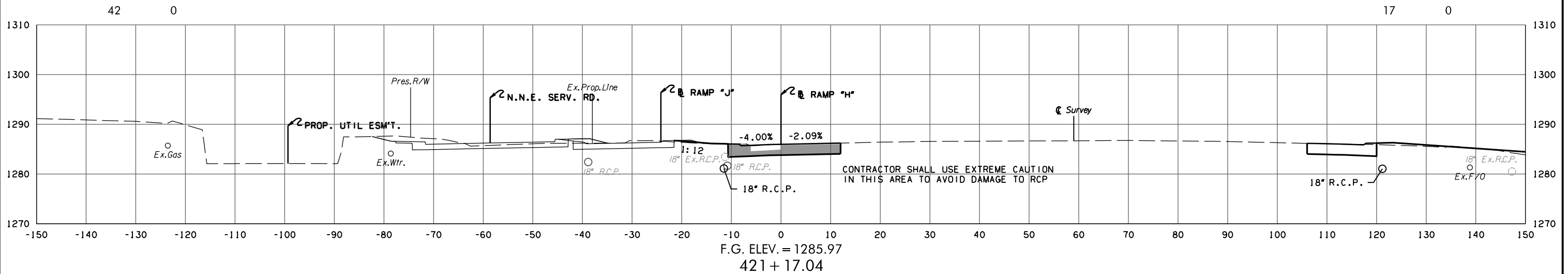
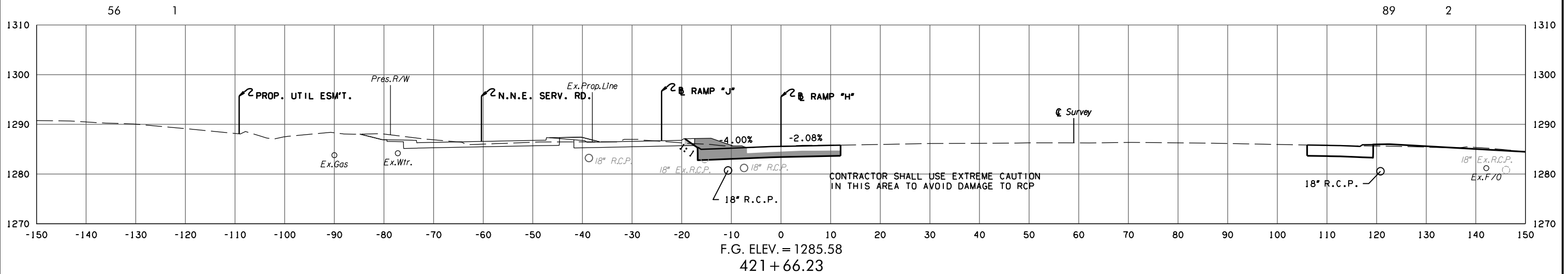

RAMP H PHASE 4

STATE JOB NO. 09032(08)
OKLAHOMA COUNTY SHEET NO. X186

3/4/2024 3:58:45 PM H:\PROJECTS\2785_CrossRoads_Phase 4\Roadway\Drawings\Sections\0903208-XSEC_Ramp_H.dgn

(CAUTION) THE LOCATION OF ALL UTILITIES AS SHOWN ARE APPROXIMATE. DUE TO RELOCATION'S PLANNED OR PRESENTLY UNDER CONSTRUCTION THERE ARE SOME UTILITIES THAT WILL BE RELOCATED AND NOT SHOWN ON THESE PLANS. THE CONTRACTOR SHALL BE RESPONSIBLE FOR ANY DAMAGE TO ALL UTILITIES.

DEPTH & LOCATION OF EXISTING UTILITIES SHALL BE FIELD VERIFIED BY THE CONTRACTOR PRIOR TO CONSTRUCTION.

SEE DRAINAGE AREA MAP SHEETS FOR DRAINAGE SYMBOLOLOGY.

R/W & U/E PURCHASED UNDER JP 09032(05)

POB & ASSOCIATES, OKLAHOMA CITY, OK.

90% PLAN SUBMITTAL

3/4/2024

AREA
CUT FILL

VOLUME
CUT FILL

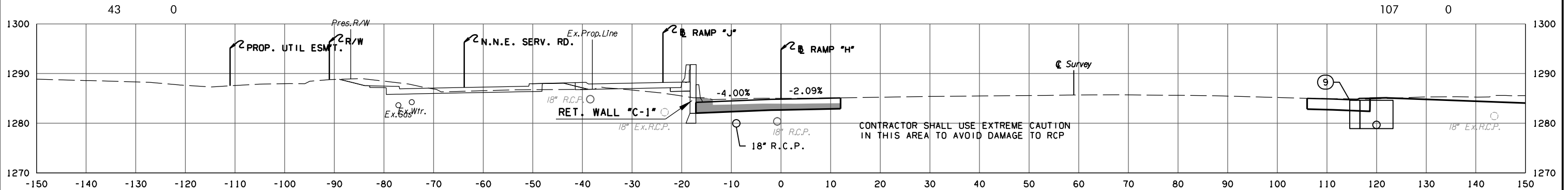

F.G. ELEV. = 1284.85
422 + 63.37

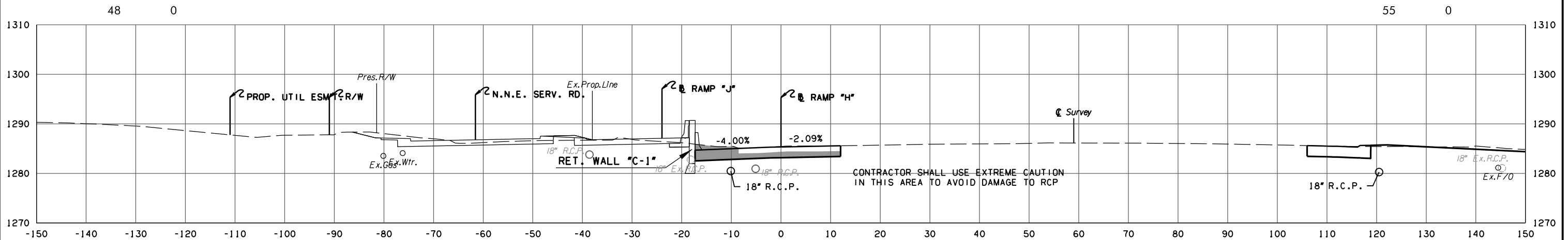

F.G. ELEV. = 1285.33
422 + 00.00

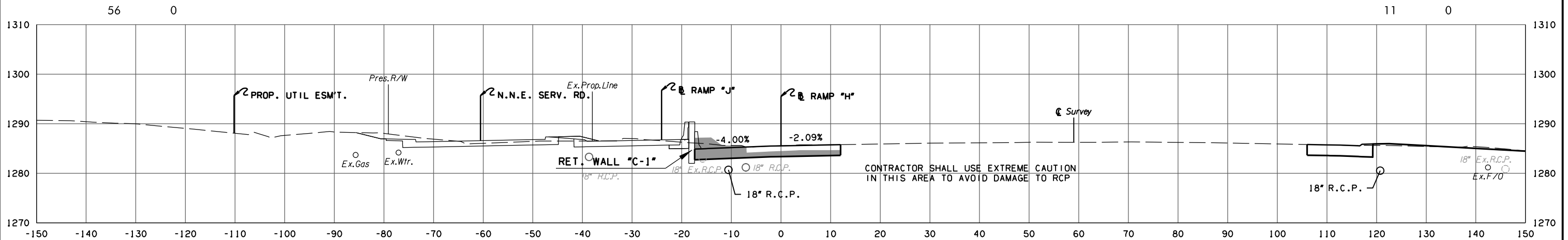

F.G. ELEV. = 1285.54
421 + 71.30

RAMP H PHASE 4

STATE JOB NO. 09032(08)
OKLAHOMA COUNTY SHEET NO. X187

3/4/2024 3:58:16 PM H:\PROJECTS\2785_CrossRoads_Phase 4\Roadway\Drawings\Sections\0903208-XSEC_Ramp_H.dgn

(CAUTION) THE LOCATION OF ALL UTILITIES AS SHOWN ARE APPROXIMATE. DUE TO RELOCATION'S PLANNED OR PRESENTLY UNDER CONSTRUCTION THERE ARE SOME UTILITIES THAT WILL BE RELOCATED AND NOT SHOWN ON THESE PLANS. THE CONTRACTOR SHALL BE RESPONSIBLE FOR ANY DAMAGE TO ALL UTILITIES.

DEPTH & LOCATION OF EXISTING UTILITIES SHALL BE FIELD VERIFIED BY THE CONTRACTOR PRIOR TO CONSTRUCTION.

SEE DRAINAGE AREA MAP SHEETS FOR DRAINAGE SYMBOLOLOGY.

R/W & U/E PURCHASED UNDER JP 09032(105)

POE & ASSOCIATES, OKLAHOMA CITY, OK.

90% PLAN SUBMITTAL

3/4/2024

AREA

CUT	FILL
43	0

VOLUME

CUT	FILL
23	0

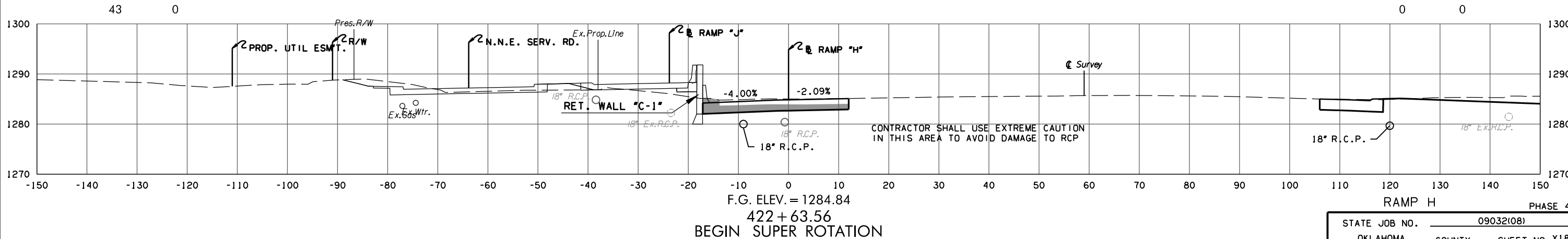
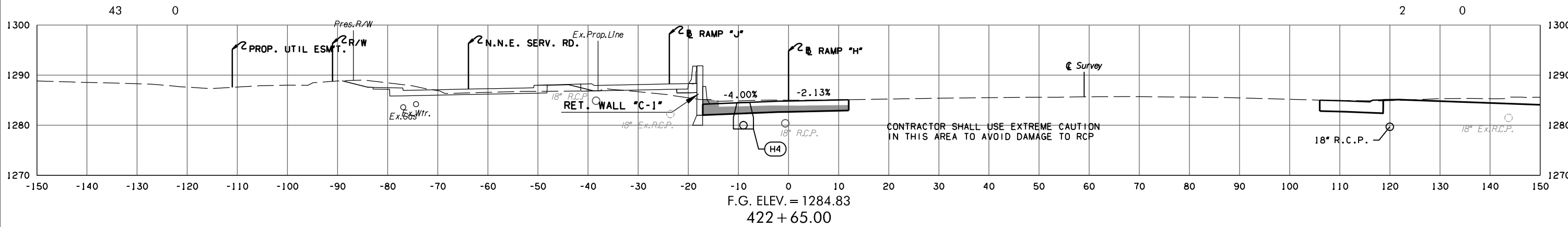
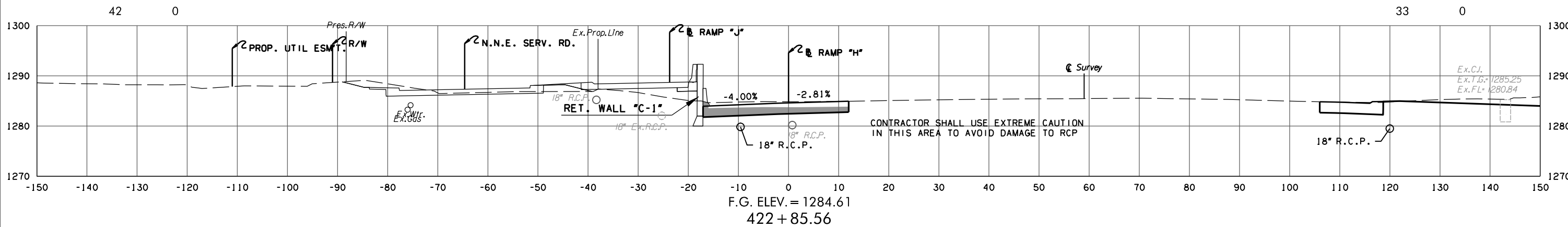
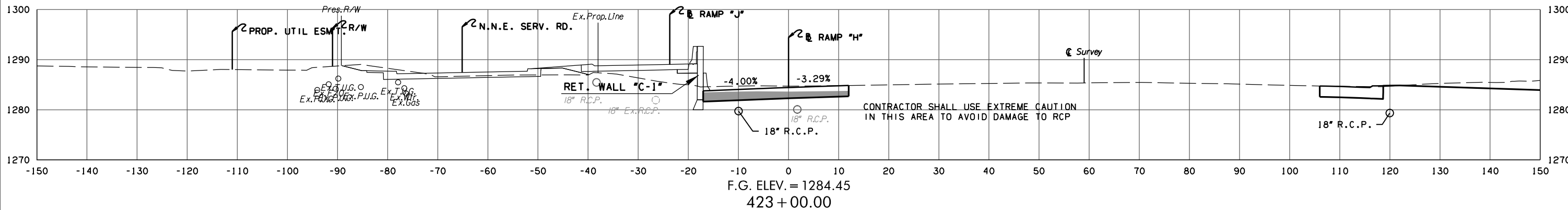

3/4/2024 3:58:17 PM H:\PROJECTS\2789_CrossRoads_Phase 4\Roadway\Drawings\Sections\0903208-XSEC-Ramp_H.dgn

(CAUTION) THE LOCATION OF ALL UTILITIES AS SHOWN ARE APPROXIMATE. DUE TO RELOCATION'S PLANNED OR PRESENTLY UNDER CONSTRUCTION THERE ARE SOME UTILITIES THAT WILL BE RELOCATED AND NOT SHOWN ON THESE PLANS. THE CONTRACTOR SHALL BE RESPONSIBLE FOR ANY DAMAGE TO ALL UTILITIES.

DEPTH & LOCATION OF EXISTING UTILITIES SHALL BE FIELD VERIFIED BY THE CONTRACTOR PRIOR TO CONSTRUCTION.

SEE DRAINAGE AREA MAP SHEETS FOR DRAINAGE SYMBOLOLOGY.

R/W & U/E PURCHASED UNDER JP 09032(05)

POE & ASSOCIATES, OKLAHOMA CITY, OK.

**90% PLAN
SUBMITTAL**

3/4/2024

AREA
CUT FILL

VOLUME
CUT FILL

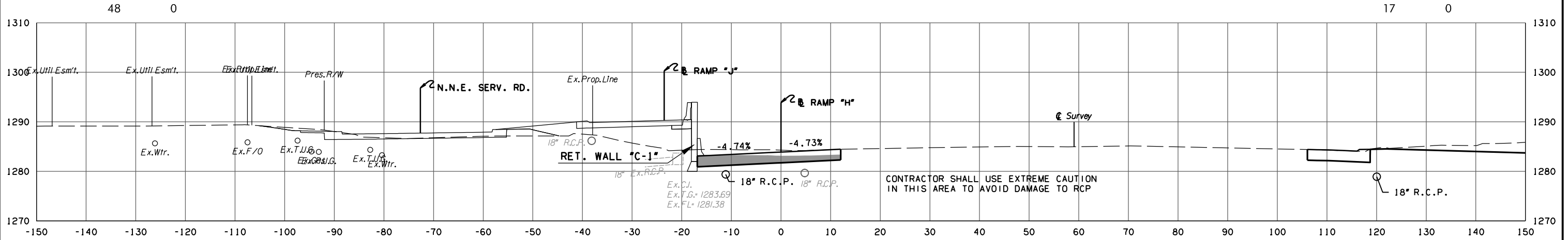

F.G. ELEV. = 1283.90
423 + 43.26

CONTRACTOR SHALL USE EXTREME CAUTION
IN THIS AREA TO AVOID DAMAGE TO RCP

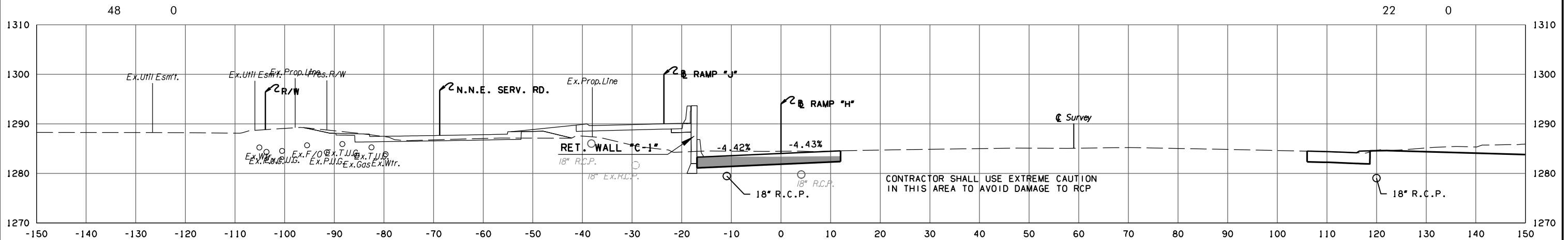

F.G. ELEV. = 1284.02
423 + 33.91

CONTRACTOR SHALL USE EXTREME CAUTION
IN THIS AREA TO AVOID DAMAGE TO RCP

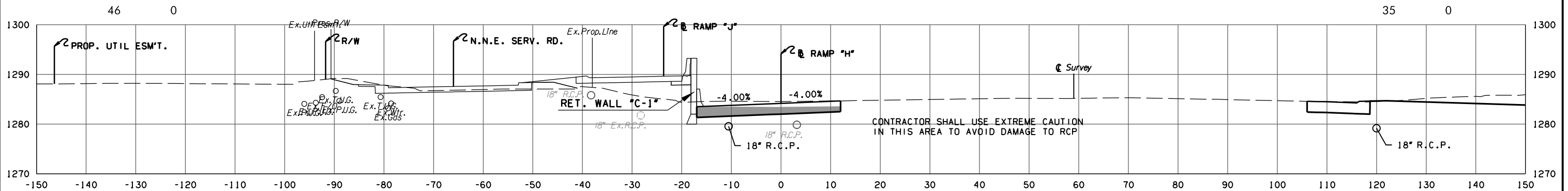

F.G. ELEV. = 1284.18
423 + 21.16

CONTRACTOR SHALL USE EXTREME CAUTION
IN THIS AREA TO AVOID DAMAGE TO RCP

RAMP H PHASE 4

STATE JOB NO. 09032(08)
OKLAHOMA COUNTY SHEET NO. X189

3/4/2024 3:58:48 PM H:\PROJECTS\2789_CrossRoads_Phase 4\Roadway\Drawings\Sections\0903208-XSEC_Ramp_H.dgn

(CAUTION) THE LOCATION OF ALL UTILITIES AS SHOWN ARE APPROXIMATE. DUE TO RELOCATION'S PLANNED OR PRESENTLY UNDER CONSTRUCTION THERE ARE SOME UTILITIES THAT WILL BE RELOCATED AND NOT SHOWN ON THESE PLANS. THE CONTRACTOR SHALL BE RESPONSIBLE FOR ANY DAMAGE TO ALL UTILITIES. DEPTH & LOCATION OF EXISTING UTILITIES SHALL BE FIELD VERIFIED BY THE CONTRACTOR PRIOR TO CONSTRUCTION.

SEE DRAINAGE AREA MAP SHEETS FOR DRAINAGE SYMBOLOLOGY.

R/W & U/E PURCHASED UNDER JP 09032(05)

POB & ASSOCIATES, OKLAHOMA CITY, OK.
90% PLAN SUBMITTAL
 3/4/2024

AREA
 CUT FILL

VOLUME
 CUT FILL

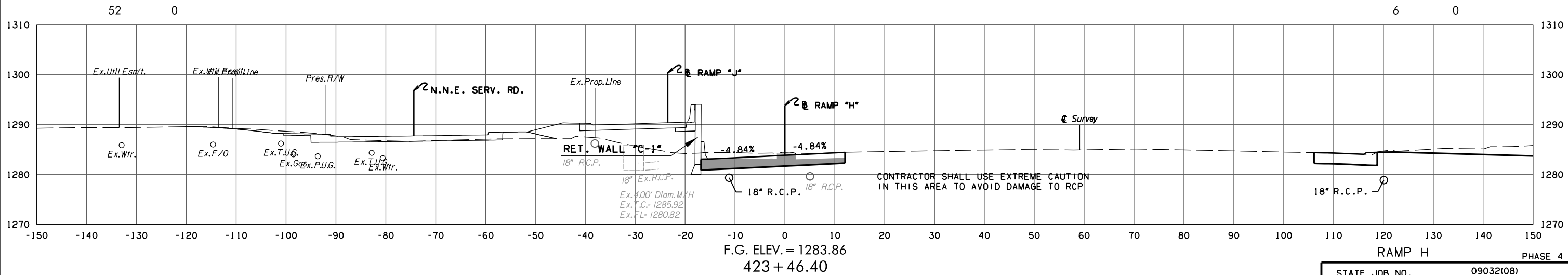
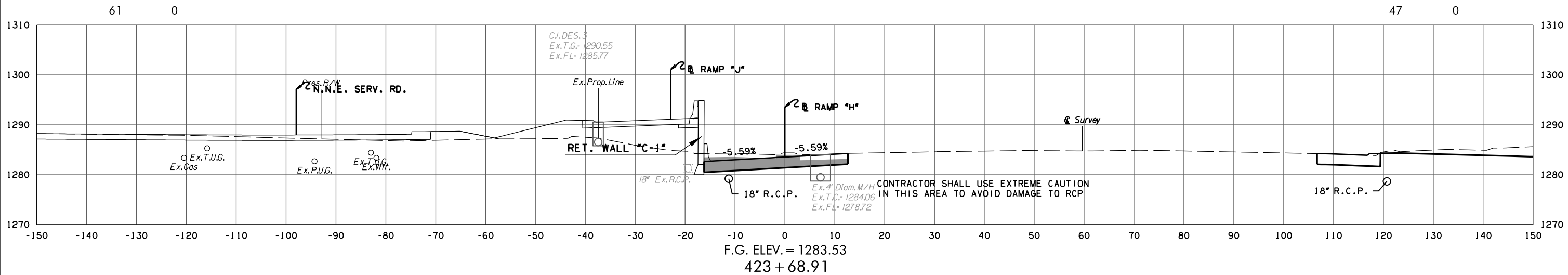
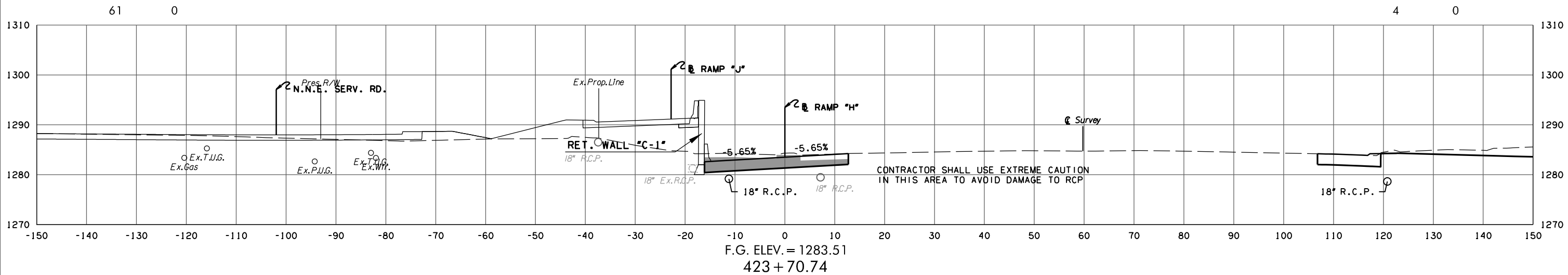

RAMP H PHASE 4
 STATE JOB NO. 09032(08)
 OKLAHOMA COUNTY SHEET NO. X190

3/4/2024 3:58:19 PM
 H:\PROJECTS\2785_CrossRoads_Phase 4\Roadway\Drawings\Sections\0903208-XSEC_Ramp_H.dgn

(CAUTION) THE LOCATION OF ALL UTILITIES AS SHOWN ARE APPROXIMATE. DUE TO RELOCATION'S PLANNED OR PRESENTLY UNDER CONSTRUCTION THERE ARE SOME UTILITIES THAT WILL BE RELOCATED AND NOT SHOWN ON THESE PLANS. THE CONTRACTOR SHALL BE RESPONSIBLE FOR ANY DAMAGE TO ALL UTILITIES.

DEPTH & LOCATION OF EXISTING UTILITIES SHALL BE FIELD VERIFIED BY THE CONTRACTOR PRIOR TO CONSTRUCTION.

SEE DRAINAGE AREA MAP SHEETS FOR DRAINAGE SYMBOLOLOGY.

R/W & U/E PURCHASED UNDER JP 09032(05)

POB & ASSOCIATES, OKLAHOMA CITY, OK.

**90% PLAN
SUBMITTAL**

3/4/2024

AREA
CUT FILL

VOLUME
CUT FILL

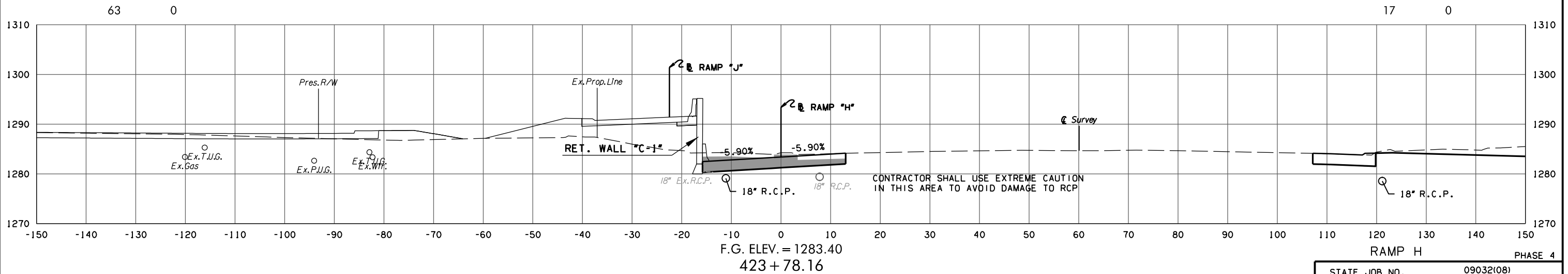
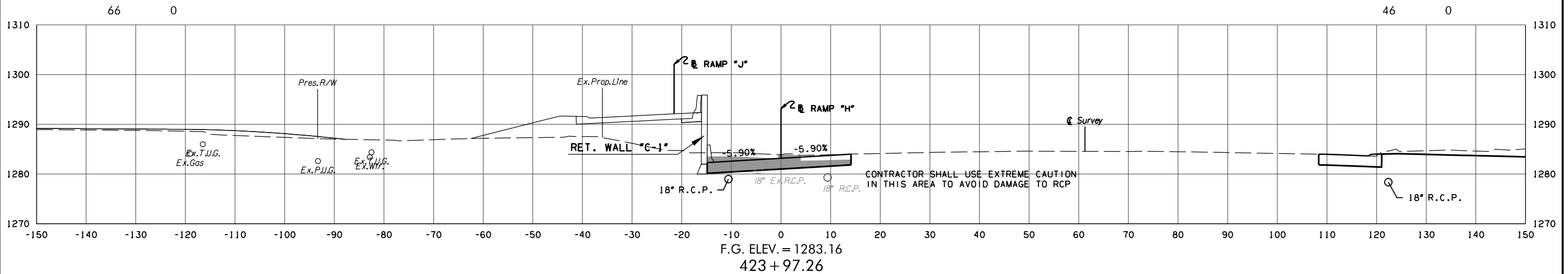
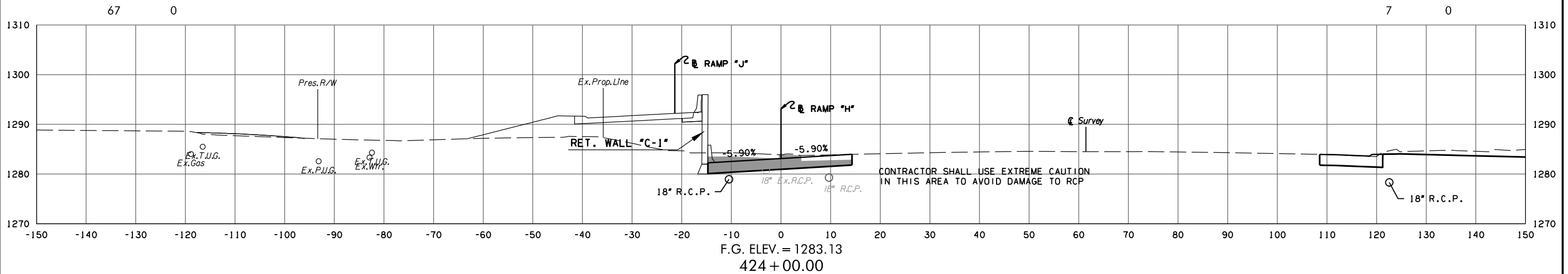

F.G. ELEV. = 1283.40
423 + 78.16
BEGIN FULL SUPER ROTATION

STATE JOB NO. 09032(08)
OKLAHOMA COUNTY SHEET NO. X191

3/4/2024 3:58:20 PM H:\PROJECTS\2785_CrossRoads_Phase 4\Roadway\Drawings\Sections\0903208-XSEC_Ramp_H.dgn

(CAUTION) THE LOCATION OF ALL UTILITIES AS SHOWN ARE APPROXIMATE. DUE TO RELOCATION'S PLANNED OR PRESENTLY UNDER CONSTRUCTION THERE ARE SOME UTILITIES THAT WILL BE RELOCATED AND NOT SHOWN ON THESE PLANS. THE CONTRACTOR SHALL BE RESPONSIBLE FOR ANY DAMAGE TO ALL UTILITIES.

DEPTH & LOCATION OF EXISTING UTILITIES SHALL BE FIELD VERIFIED BY THE CONTRACTOR PRIOR TO CONSTRUCTION.

SEE DRAINAGE AREA MAP SHEETS FOR DRAINAGE SYMBOLOLOGY.

R/W & U/E PURCHASED UNDER JP 09032(05)

POB & ASSOCIATES, OKLAHOMA CITY, OK.

**90% PLAN
SUBMITTAL**

3/4/2024

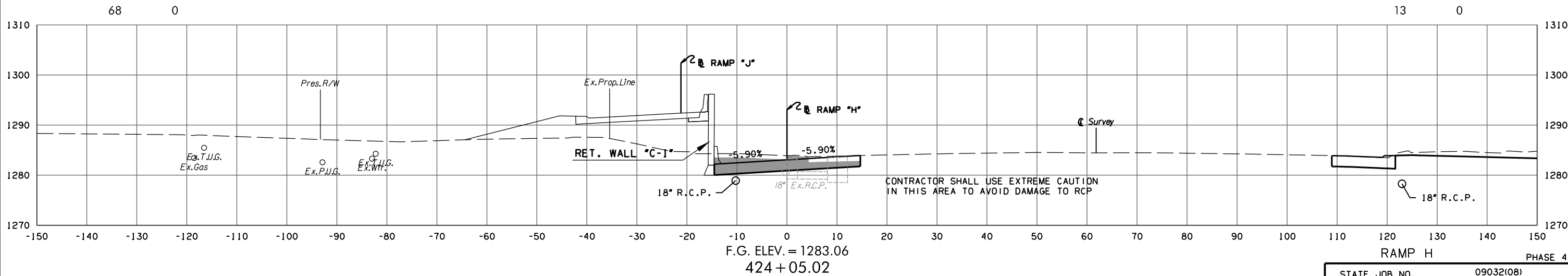
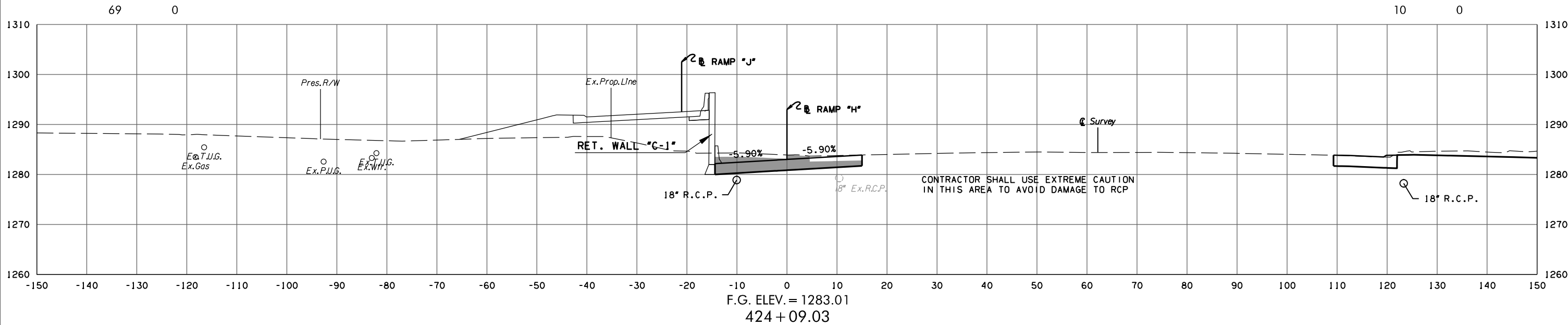
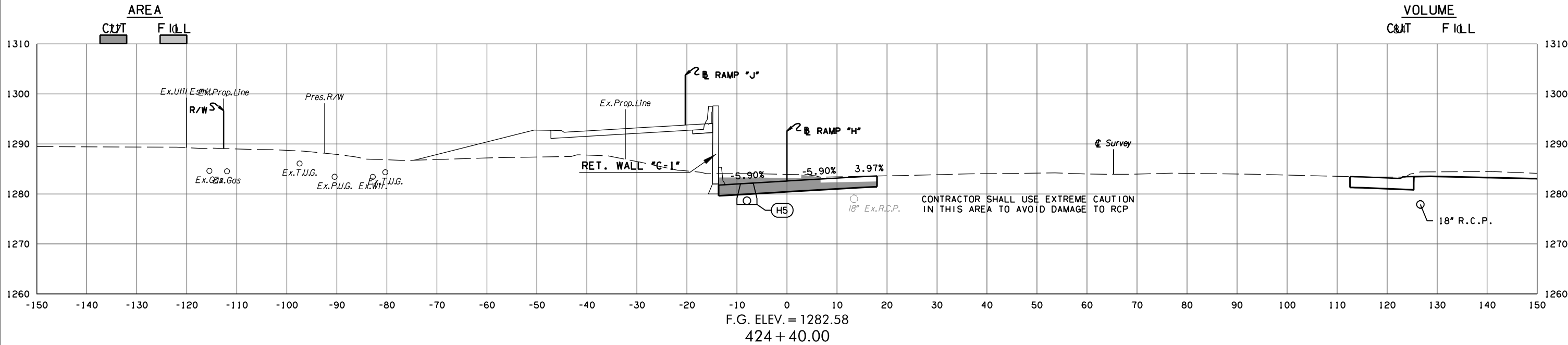

STATE JOB NO. 09032(08)
OKLAHOMA COUNTY SHEET NO. X192

3/4/2024 3:58:21 PM H:\PROJECTS\2789_CrossRoads_Phase 4\Roadway\Drawings\Sections\0903208-XSEC_Ramp_H.dgn

(CAUTION) THE LOCATION OF ALL UTILITIES AS SHOWN ARE APPROXIMATE. DUE TO RELOCATION'S PLANNED OR PRESENTLY UNDER CONSTRUCTION THERE ARE SOME UTILITIES THAT WILL BE RELOCATED AND NOT SHOWN ON THESE PLANS. THE CONTRACTOR SHALL BE RESPONSIBLE FOR ANY DAMAGE TO ALL UTILITIES. DEPTH & LOCATION OF EXISTING UTILITIES SHALL BE FIELD VERIFIED BY THE CONTRACTOR PRIOR TO CONSTRUCTION.

SEE DRAINAGE AREA MAP SHEETS FOR DRAINAGE SYMBOLOLOGY.

R/W & U/E PURCHASED UNDER JP 09032(05)

POE & ASSOCIATES, OKLAHOMA CITY, OK.
90% PLAN
SUBMITTAL
 3/4/2024

AREA
 CUT FILL

VOLUME
 CUT FILL

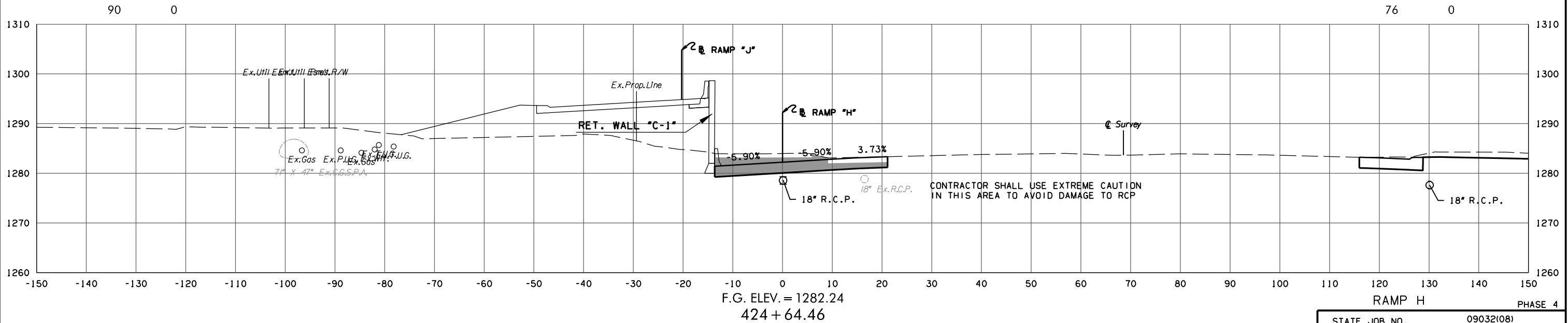
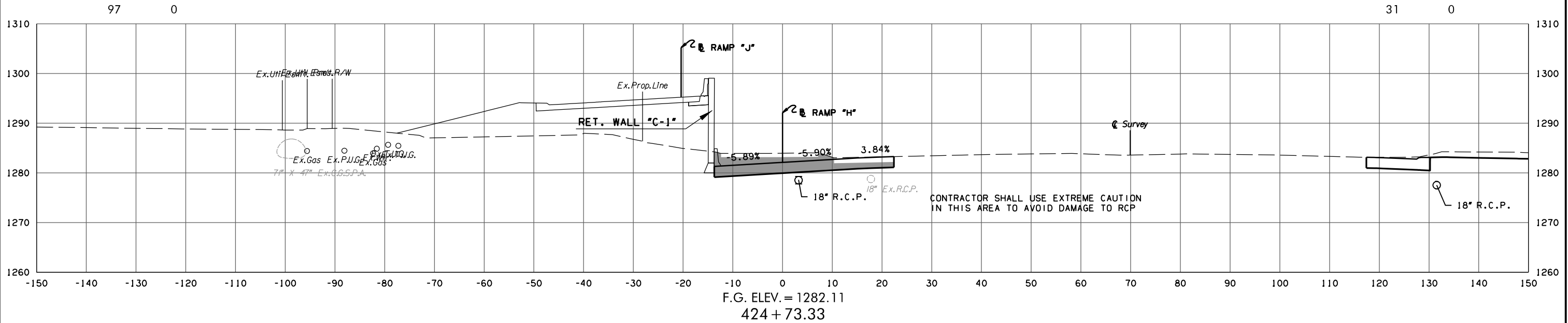

RAMP H PHASE 4

STATE JOB NO. 09032(08)
 OKLAHOMA COUNTY SHEET NO. X193

3/4/2024 3:58:22 PM H:\PROJECTS\2789_CrossRoads_Phase 4\Roadway\Drawings\Sections\0903208-XSEC_Ramp_H.dgn

(CAUTION) THE LOCATION OF ALL UTILITIES AS SHOWN ARE APPROXIMATE. DUE TO RELOCATION'S PLANNED OR PRESENTLY UNDER CONSTRUCTION THERE ARE SOME UTILITIES THAT WILL BE RELOCATED AND NOT SHOWN ON THESE PLANS. THE CONTRACTOR SHALL BE RESPONSIBLE FOR ANY DAMAGE TO ALL UTILITIES. DEPTH & LOCATION OF EXISTING UTILITIES SHALL BE FIELD VERIFIED BY THE CONTRACTOR PRIOR TO CONSTRUCTION.

SEE DRAINAGE AREA MAP SHEETS FOR DRAINAGE SYMBOLOLOGY.

R/W & U/E PURCHASED UNDER JP 09032(05)

POB & ASSOCIATES, OKLAHOMA CITY, OK.
90% PLAN SUBMITTAL
 3/4/2024

AREA
 CUT FILL

VOLUME
 CUT FILL

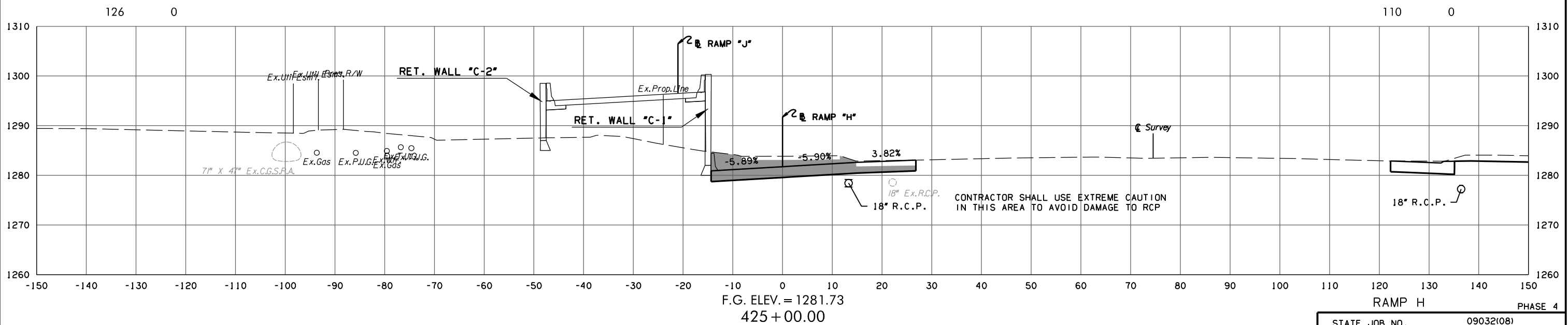
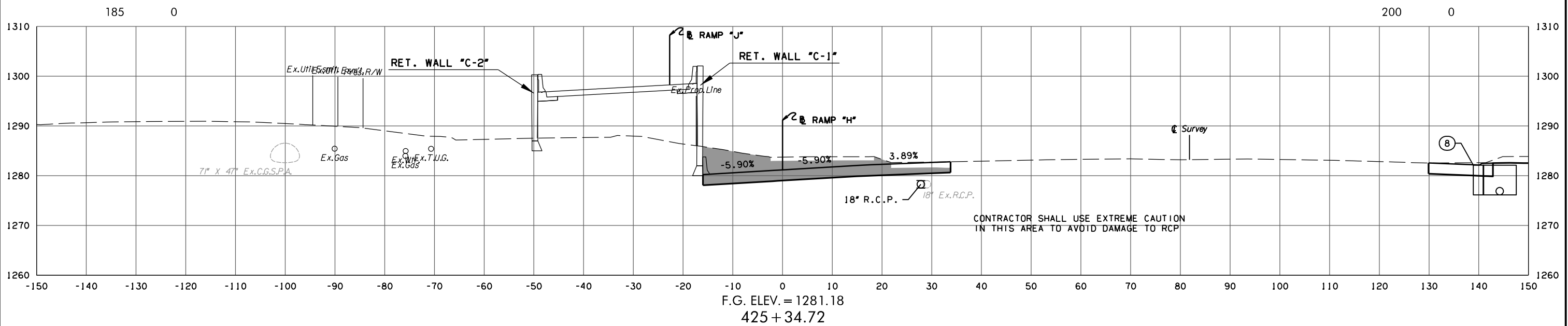

RAMP H PHASE 4

STATE JOB NO. 09032(08)
 OKLAHOMA COUNTY SHEET NO. X194

3/4/2024 3:58:24 PM
 H:\PROJECTS\2789_CrossRoads_Phase 4\Roadway\Drawings\Sections\0903208-XSEC_Ramp_H.dgn

(CAUTION) THE LOCATION OF ALL UTILITIES AS SHOWN ARE APPROXIMATE. DUE TO RELOCATION'S PLANNED OR PRESENTLY UNDER CONSTRUCTION THERE ARE SOME UTILITIES THAT WILL BE RELOCATED AND NOT SHOWN ON THESE PLANS. THE CONTRACTOR SHALL BE RESPONSIBLE FOR ANY DAMAGE TO ALL UTILITIES.

DEPTH & LOCATION OF EXISTING UTILITIES SHALL BE FIELD VERIFIED BY THE CONTRACTOR PRIOR TO CONSTRUCTION.

SEE DRAINAGE AREA MAP SHEETS FOR DRAINAGE SYMBOLOLOGY.

R/W & U/E PURCHASED UNDER JP 09032(05)

POE & ASSOCIATES, OKLAHOMA CITY, OK.

**90% PLAN
SUBMITTAL**

3/4/2024

AREA
CUT FILL

VOLUME
CUT FILL

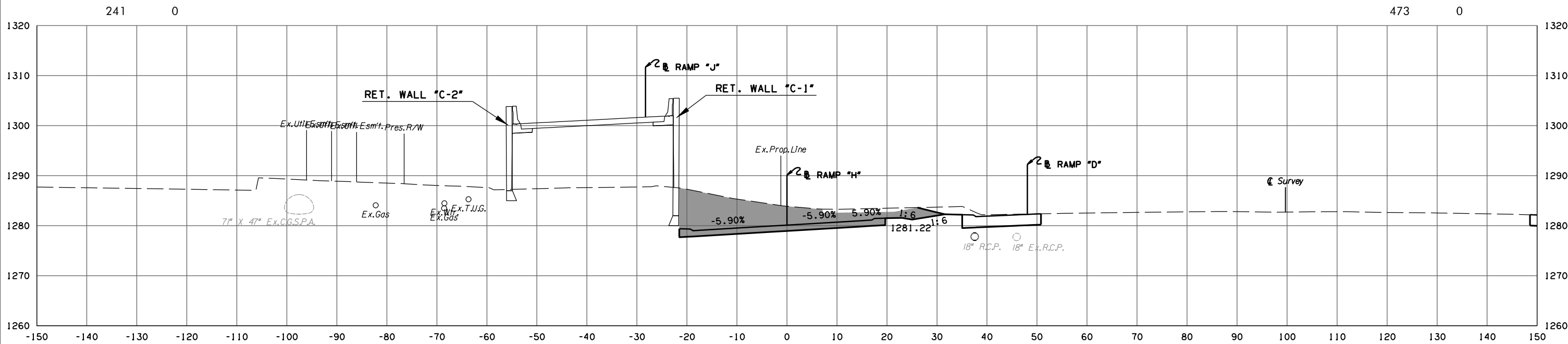

F.G. ELEV. = 1280.12
426 + 00.00

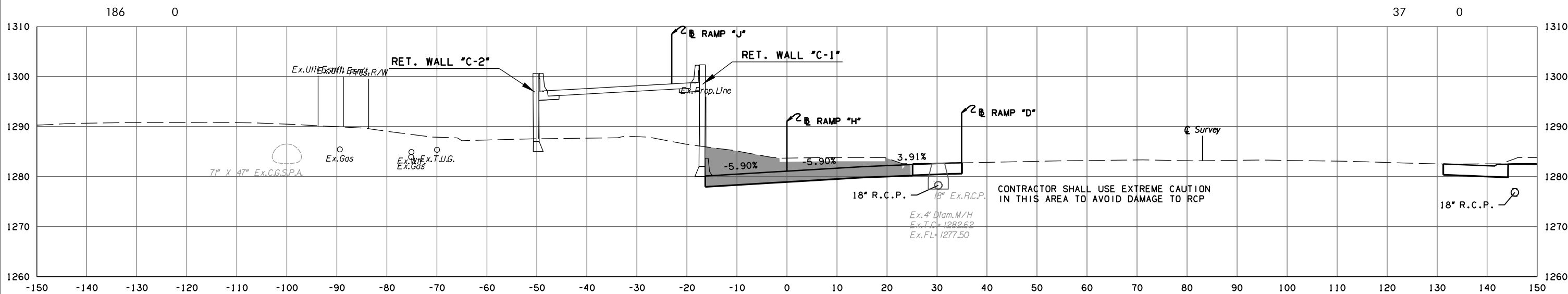

F.G. ELEV. = 1281.08
425 + 40.13

RAMP H PHASE 4

STATE JOB NO. 09032(08)
OKLAHOMA COUNTY SHEET NO. X195

3/4/2024 3:58:25 PM H:\PROJECTS\2789_CrossRoads_Phase 4\Roadway\Drawings\Sections\0903208-XSEC_Ramp_H.dgn

(CAUTION) THE LOCATION OF ALL UTILITIES AS SHOWN ARE APPROXIMATE. DUE TO RELOCATION'S PLANNED OR PRESENTLY UNDER CONSTRUCTION THERE ARE SOME UTILITIES THAT WILL BE RELOCATED AND NOT SHOWN ON THESE PLANS. THE CONTRACTOR SHALL BE RESPONSIBLE FOR ANY DAMAGE TO ALL UTILITIES.

SEE DRAINAGE AREA MAP SHEETS FOR DRAINAGE SYMBOLOLOGY.

R/W & U/E PURCHASED UNDER JP 09032(05)

POB & ASSOCIATES, OKLAHOMA CITY, OK.

**90% PLAN
SUBMITTAL**

3/4/2024

DEPTH & LOCATION OF EXISTING UTILITIES SHALL BE FIELD VERIFIED BY THE CONTRACTOR PRIOR TO CONSTRUCTION.

AREA
CUT FILL

VOLUME
CUT FILL

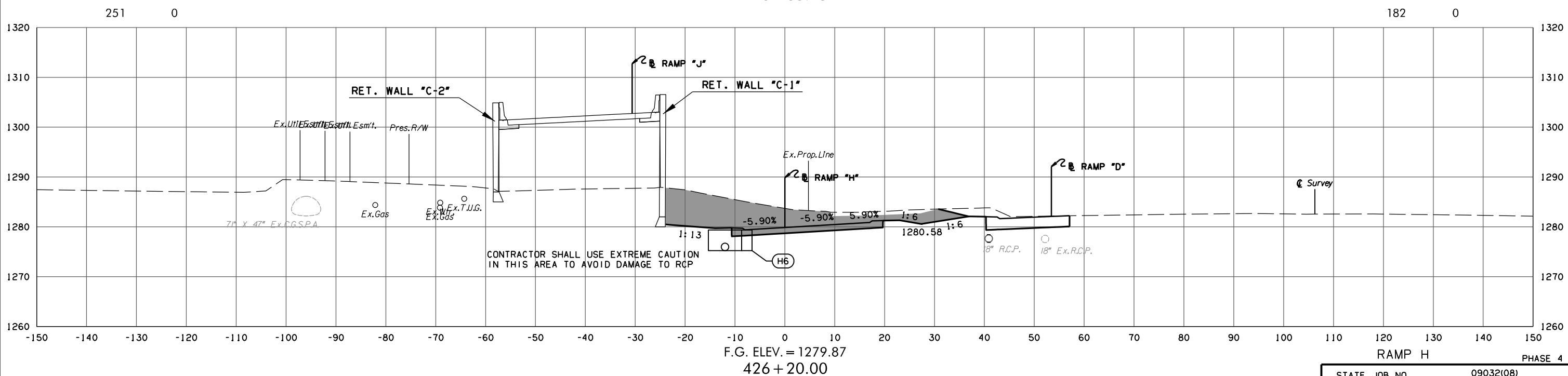
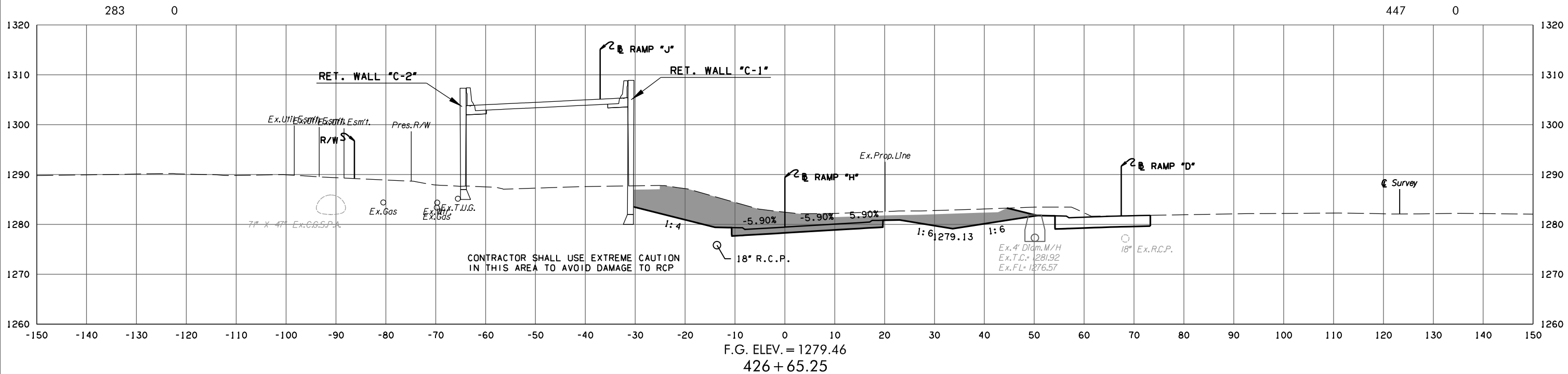

3/4/2024 3:58:26 PM H:\PROJECTS\2789_CrossRoads_Phase 4\Roadway\Drawings\Sections\0903208-XSEC_Ramp_H.dgn

(CAUTION) THE LOCATION OF ALL UTILITIES AS SHOWN ARE APPROXIMATE. DUE TO RELOCATION'S PLANNED OR PRESENTLY UNDER CONSTRUCTION THERE ARE SOME UTILITIES THAT WILL BE RELOCATED AND NOT SHOWN ON THESE PLANS. THE CONTRACTOR SHALL BE RESPONSIBLE FOR ANY DAMAGE TO ALL UTILITIES.

DEPTH & LOCATION OF EXISTING UTILITIES SHALL BE FIELD VERIFIED BY THE CONTRACTOR PRIOR TO CONSTRUCTION.

SEE DRAINAGE AREA MAP SHEETS FOR DRAINAGE SYMBOLOLOGY.

R/W & U/E PURCHASED UNDER JP 09032(05)

POB & ASSOCIATES, OKLAHOMA CITY, OK.

**90% PLAN
SUBMITTAL**

3/4/2024

AREA
CUT FILL

VOLUME
CUT FILL

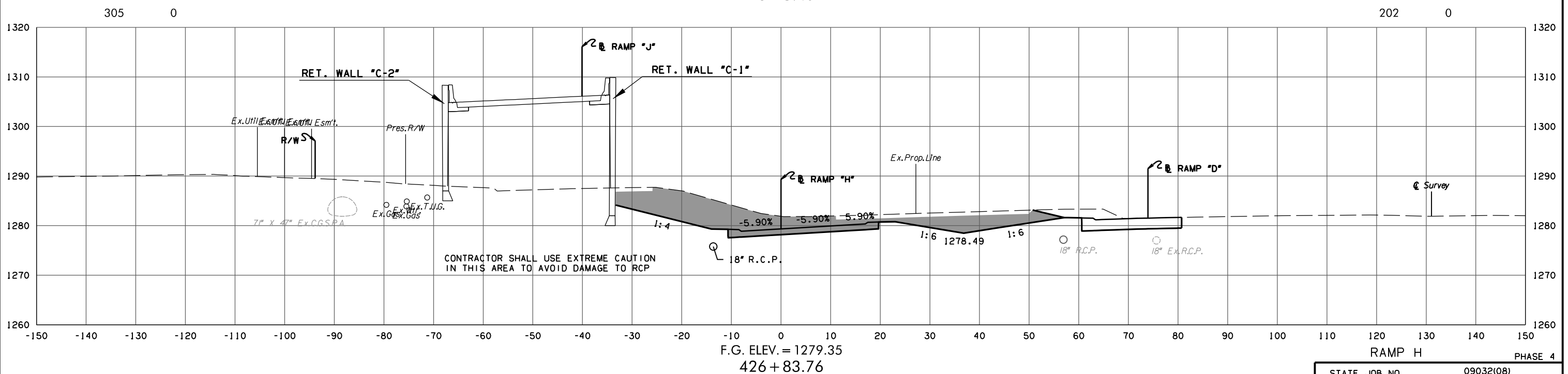
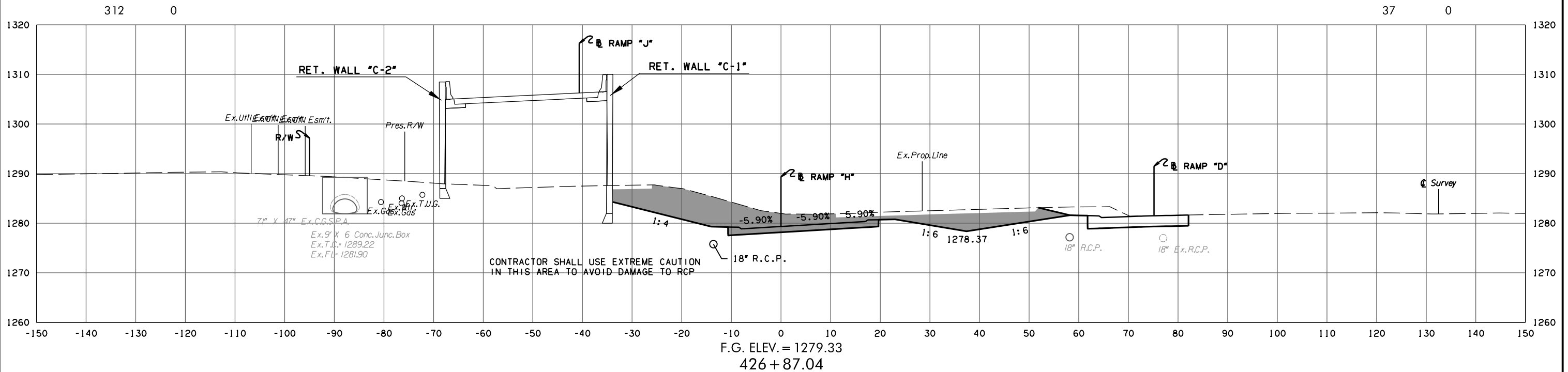

3/4/2024 3:58:27 PM H:\PROJECTS\2789_CrossRoads_Phase 4\Roadway\Drawings\Sections\0903208-XSEC_Ramp_H.dgn

(CAUTION) THE LOCATION OF ALL UTILITIES AS SHOWN ARE APPROXIMATE. DUE TO RELOCATION'S PLANNED OR PRESENTLY UNDER CONSTRUCTION THERE ARE SOME UTILITIES THAT WILL BE RELOCATED AND NOT SHOWN ON THESE PLANS. THE CONTRACTOR SHALL BE RESPONSIBLE FOR ANY DAMAGE TO ALL UTILITIES.

DEPTH & LOCATION OF EXISTING UTILITIES SHALL BE FIELD VERIFIED BY THE CONTRACTOR PRIOR TO CONSTRUCTION.

SEE DRAINAGE AREA MAP SHEETS FOR DRAINAGE SYMBOLOLOGY.

R/W & U/E PURCHASED UNDER JP 09032(05)

POB & ASSOCIATES, OKLAHOMA CITY, OK.

**90% PLAN
SUBMITTAL**

3/4/2024

AREA
CUT FILL

VOLUME
CUT FILL

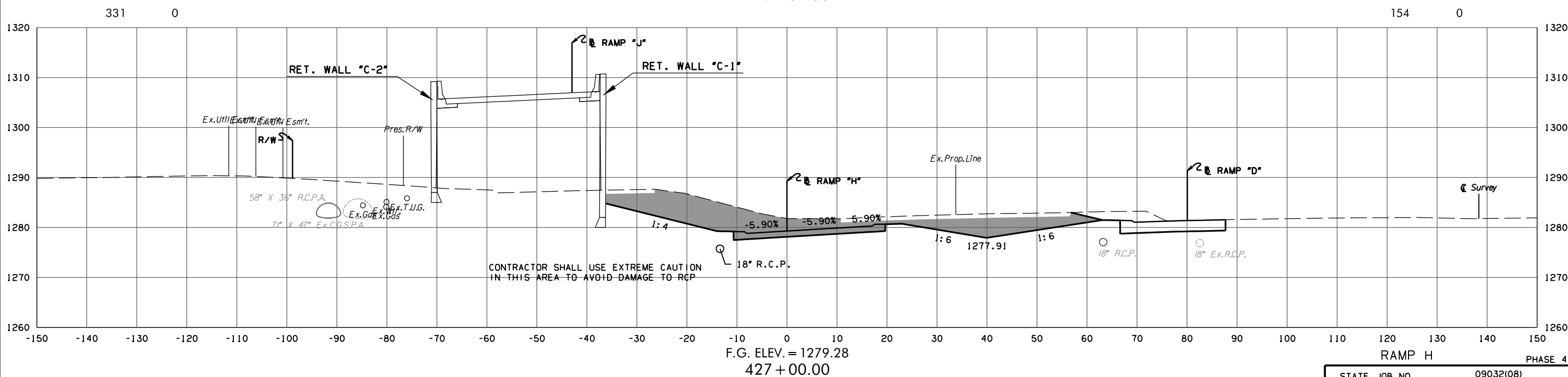
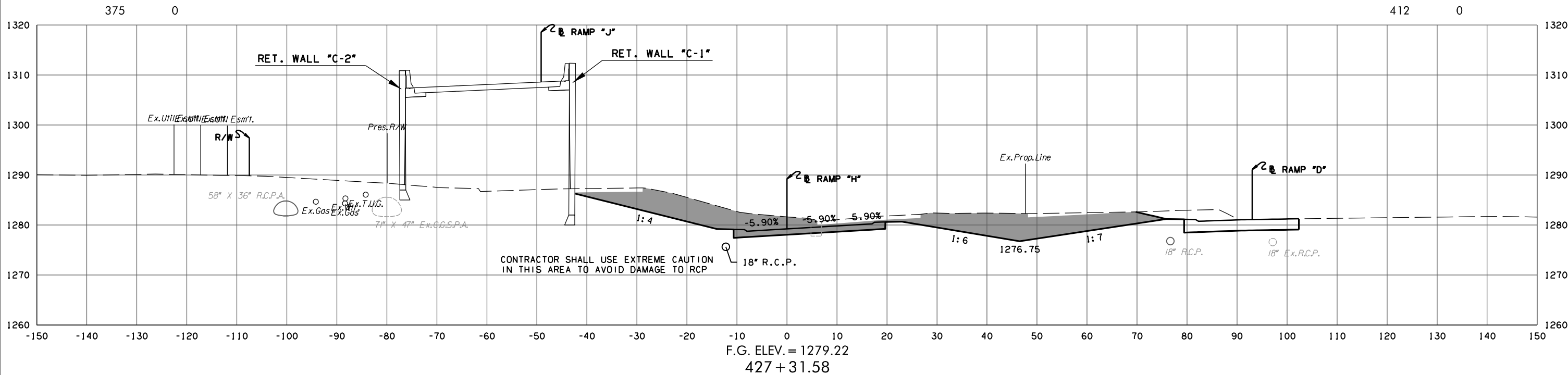

STATE JOB NO. 09032(08)
OKLAHOMA COUNTY SHEET NO. X198

3/4/2024 3:58:28 PM H:\PROJECTS\2789_CrossRoads_Phase 4\Roadway\Drawings\Sections\0903208-XSEC_Ramp_H.dgn

(CAUTION) THE LOCATION OF ALL UTILITIES AS SHOWN ARE APPROXIMATE. DUE TO RELOCATION'S PLANNED OR PRESENTLY UNDER CONSTRUCTION THERE ARE SOME UTILITIES THAT WILL BE RELOCATED AND NOT SHOWN ON THESE PLANS. THE CONTRACTOR SHALL BE RESPONSIBLE FOR ANY DAMAGE TO ALL UTILITIES.

DEPTH & LOCATION OF EXISTING UTILITIES SHALL BE FIELD VERIFIED BY THE CONTRACTOR PRIOR TO CONSTRUCTION.

SEE DRAINAGE AREA MAP SHEETS FOR DRAINAGE SYMBOLOLOGY.

R/W & U/E PURCHASED UNDER JP 09032(05)

POB & ASSOCIATES, OKLAHOMA CITY, OK.

**90% PLAN
SUBMITTAL**

3/4/2024

AREA
CUT FILL

VOLUME
CUT FILL

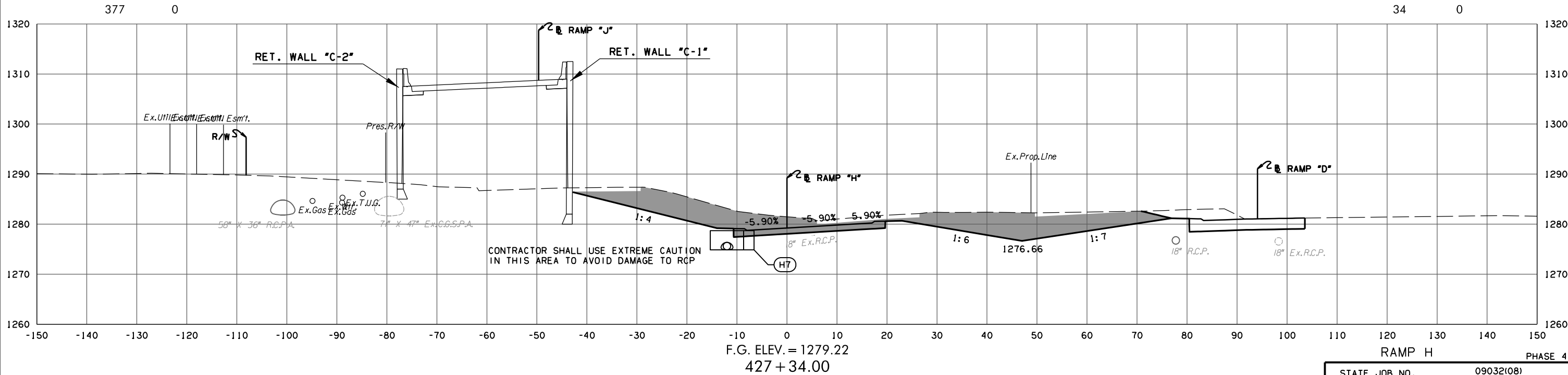
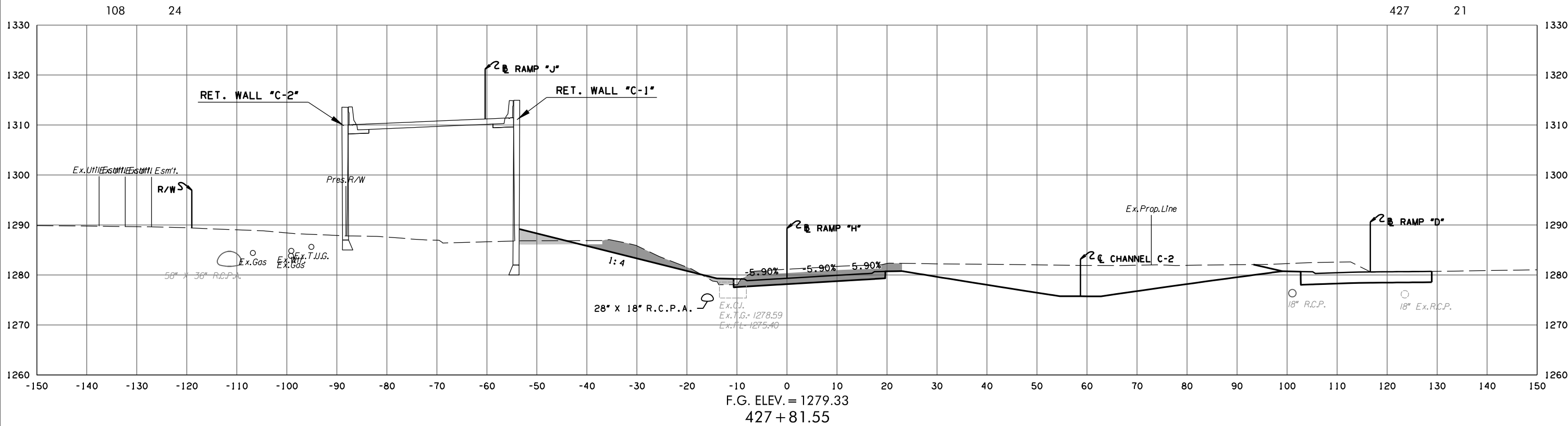

CONTRACTOR SHALL USE EXTREME CAUTION IN THIS AREA TO AVOID DAMAGE TO RCP

STATE JOB NO. 09032(08)
OKLAHOMA COUNTY SHEET NO. X199

3/4/2024 3:58:29 PM H:\PROJECTS\2789_CrossRoads_Phase 4\Roadway\Drawings\Sections\0903208-XSEC_Ramp_H.dgn

(CAUTION) THE LOCATION OF ALL UTILITIES AS SHOWN ARE APPROXIMATE. DUE TO RELOCATION'S PLANNED OR PRESENTLY UNDER CONSTRUCTION THERE ARE SOME UTILITIES THAT WILL BE RELOCATED AND NOT SHOWN ON THESE PLANS. THE CONTRACTOR SHALL BE RESPONSIBLE FOR ANY DAMAGE TO ALL UTILITIES.

DEPTH & LOCATION OF EXISTING UTILITIES SHALL BE FIELD VERIFIED BY THE CONTRACTOR PRIOR TO CONSTRUCTION.

SEE DRAINAGE AREA MAP SHEETS FOR DRAINAGE SYMBOLOLOGY.

R/W & U/E PURCHASED UNDER JP 09032(05)

POB & ASSOCIATES, OKLAHOMA CITY, OK.

**90% PLAN
SUBMITTAL**

3/4/2024

AREA
CUT FILL

VOLUME
CUT FILL

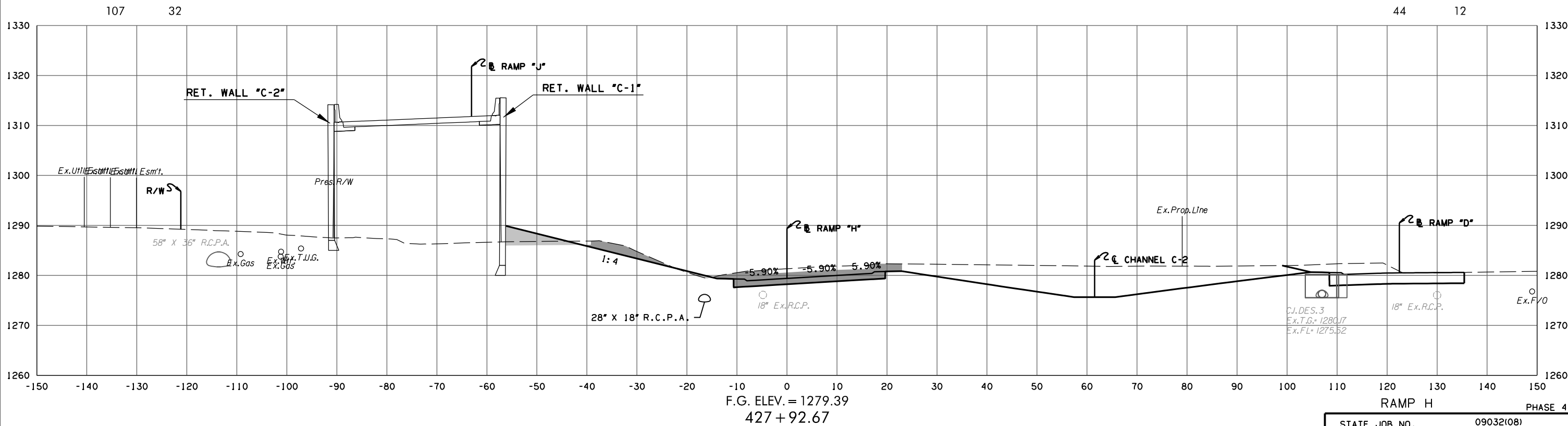
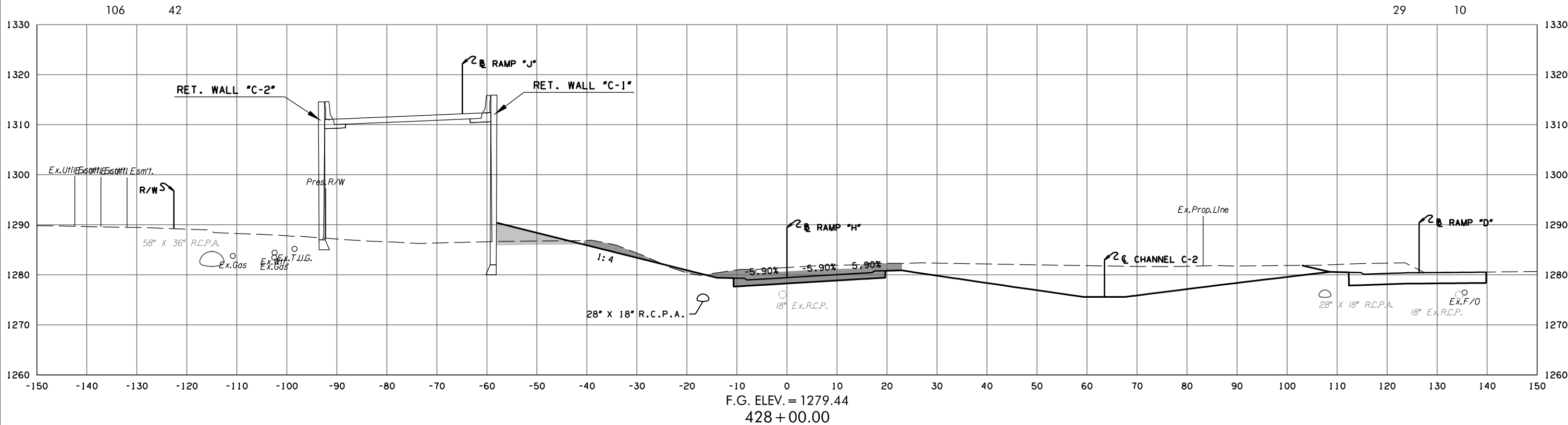

3/4/2024 3:58:30 PM H:\PROJECTS\2789_CrossRoads_Phase 4\Roadway\Drawings\Sections\0903208-XSEC_Ramp_H.dgn

STATE JOB NO. 09032(08)
OKLAHOMA COUNTY SHEET NO. X200

(CAUTION) THE LOCATION OF ALL UTILITIES AS SHOWN ARE APPROXIMATE. DUE TO RELOCATION'S PLANNED OR PRESENTLY UNDER CONSTRUCTION THERE ARE SOME UTILITIES THAT WILL BE RELOCATED AND NOT SHOWN ON THESE PLANS. THE CONTRACTOR SHALL BE RESPONSIBLE FOR ANY DAMAGE TO ALL UTILITIES. DEPTH & LOCATION OF EXISTING UTILITIES SHALL BE FIELD VERIFIED BY THE CONTRACTOR PRIOR TO CONSTRUCTION.

SEE DRAINAGE AREA MAP SHEETS FOR DRAINAGE SYMBOLOLOGY.

R/W & U/E PURCHASED UNDER JP 09032(05)

POB & ASSOCIATES, OKLAHOMA CITY, OK.
90% PLAN SUBMITTAL
 3/4/2024

AREA
 CUT FILL

VOLUME
 CUT FILL

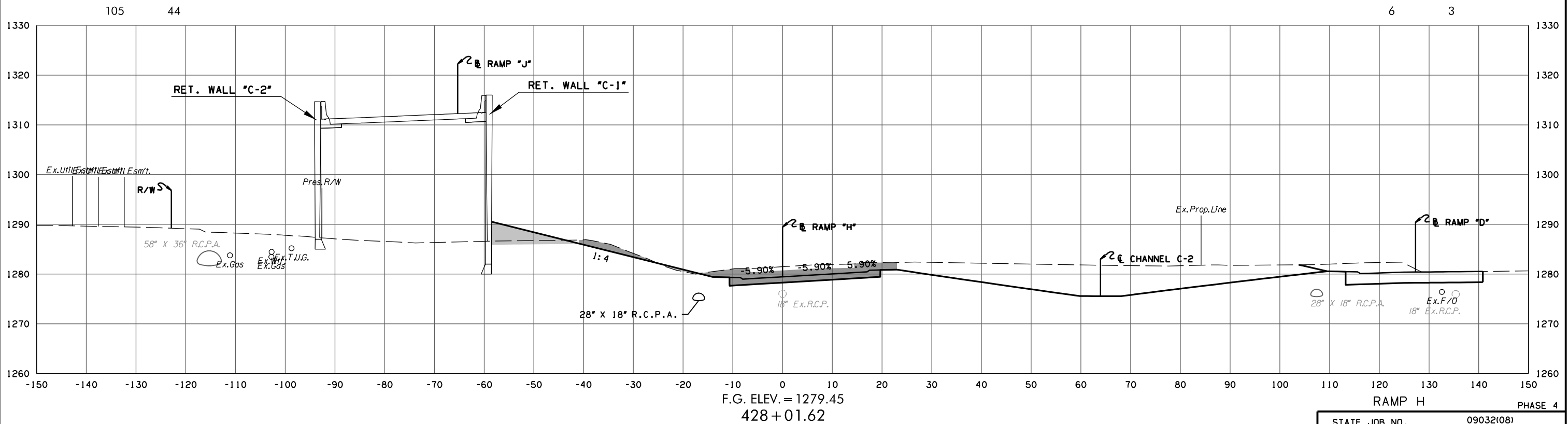
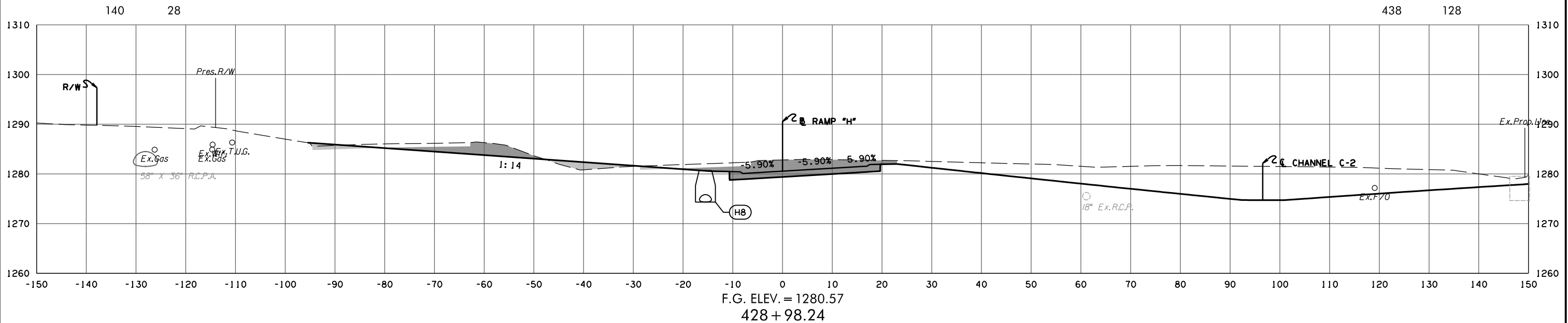

3/4/2024 3:58:31 PM H:\PROJECTS\2789_CrossRoads_Phase 4\Roadway\Drawings\Sections\0903208-XSEC_Ramp_H.dgn

STATE JOB NO. 09032(08)
 OKLAHOMA COUNTY SHEET NO. X201

(CAUTION) THE LOCATION OF ALL UTILITIES AS SHOWN ARE APPROXIMATE. DUE TO RELOCATION'S PLANNED OR PRESENTLY UNDER CONSTRUCTION THERE ARE SOME UTILITIES THAT WILL BE RELOCATED AND NOT SHOWN ON THESE PLANS. THE CONTRACTOR SHALL BE RESPONSIBLE FOR ANY DAMAGE TO ALL UTILITIES.
 DEPTH & LOCATION OF EXISTING UTILITIES SHALL BE FIELD VERIFIED BY THE CONTRACTOR PRIOR TO CONSTRUCTION.

SEE DRAINAGE AREA MAP SHEETS FOR DRAINAGE SYMBOLOLOGY.

R/W & U/E PURCHASED UNDER JP 09032(05)

POB & ASSOCIATES, OKLAHOMA CITY, OK.
90% PLAN SUBMITTAL
 3/4/2024

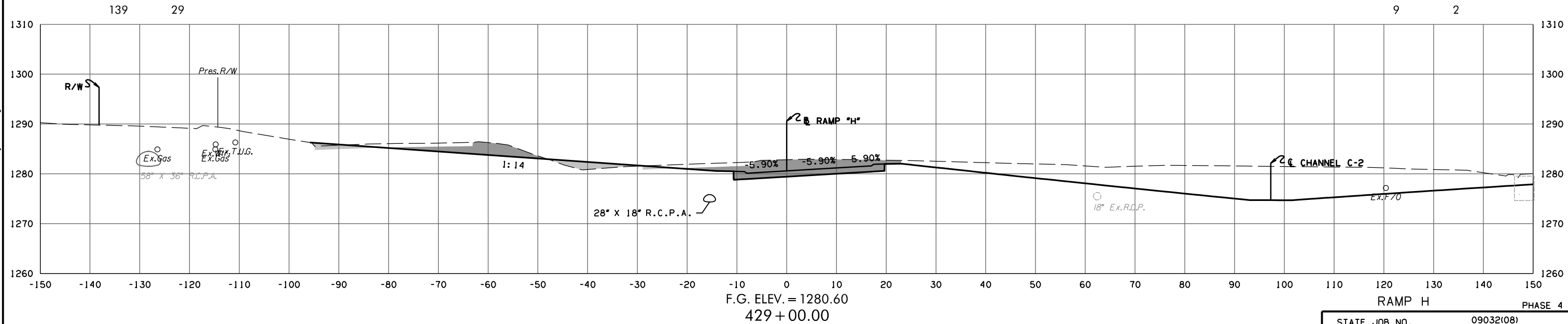
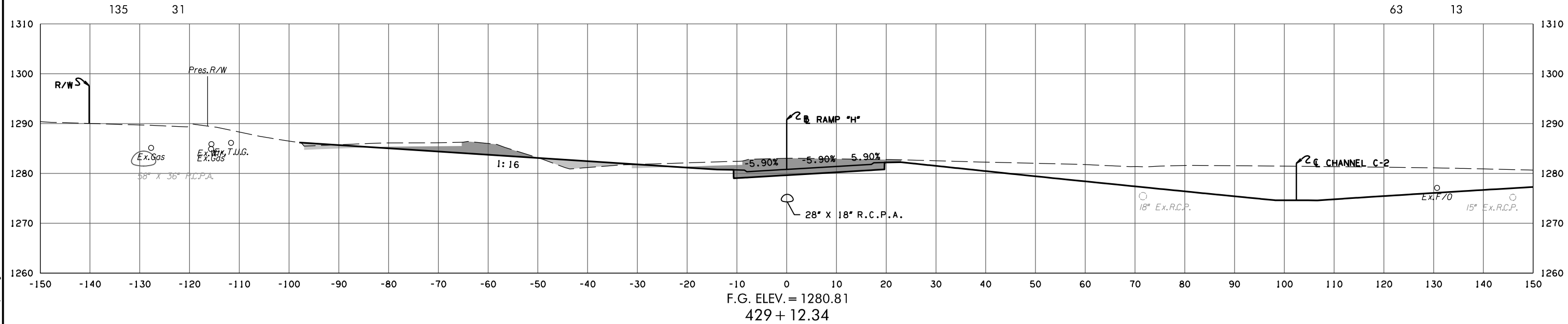
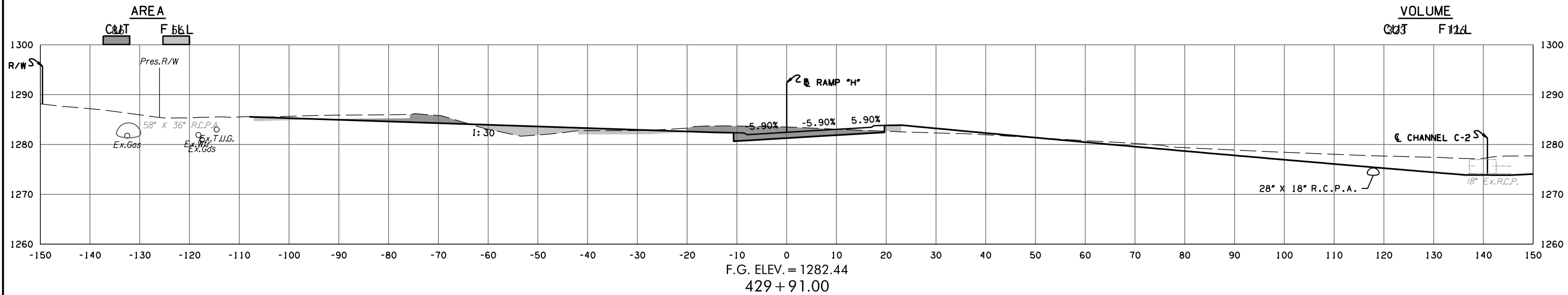

3/4/2024 3:58:32 PM H:\PROJECTS\2789_CrossRoads_Phase 4\Roadway\Drawings\Sections\0903208-XSEC_Ramp_H.dgn

(CAUTION) THE LOCATION OF ALL UTILITIES AS SHOWN ARE APPROXIMATE. DUE TO RELOCATION'S PLANNED OR PRESENTLY UNDER CONSTRUCTION THERE ARE SOME UTILITIES THAT WILL BE RELOCATED AND NOT SHOWN ON THESE PLANS. THE CONTRACTOR SHALL BE RESPONSIBLE FOR ANY DAMAGE TO ALL UTILITIES. DEPTH & LOCATION OF EXISTING UTILITIES SHALL BE FIELD VERIFIED BY THE CONTRACTOR PRIOR TO CONSTRUCTION.

SEE DRAINAGE AREA MAP SHEETS FOR DRAINAGE SYMBOLOLOGY.

R/W & U/E PURCHASED UNDER JP 09032(05)

POB & ASSOCIATES, OKLAHOMA CITY, OK.
90% PLAN SUBMITTAL
 3/4/2024

AREA
 CUT FILL

VOLUME
 CUT FILL

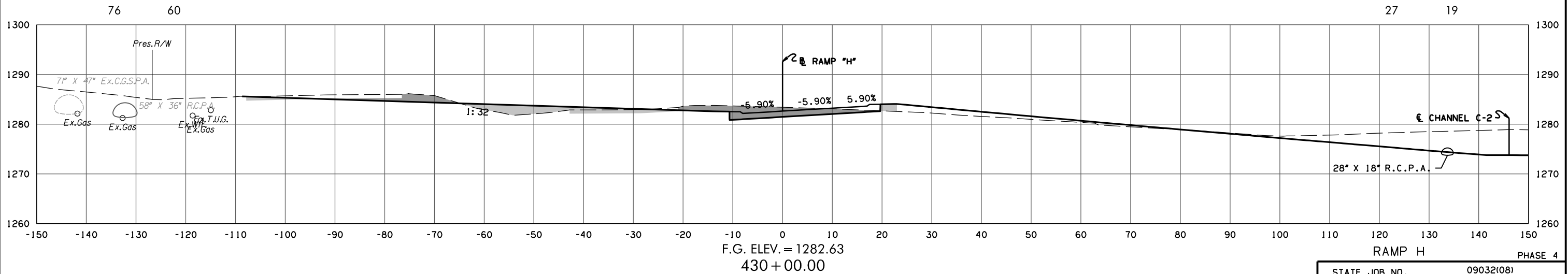
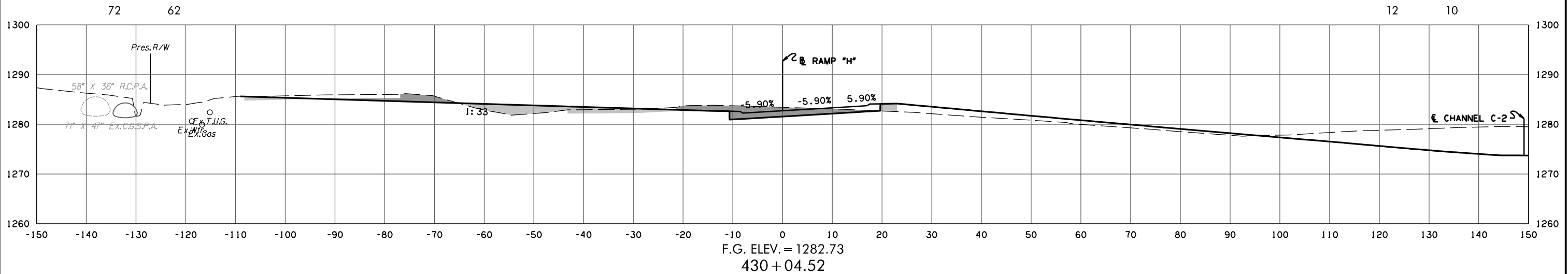
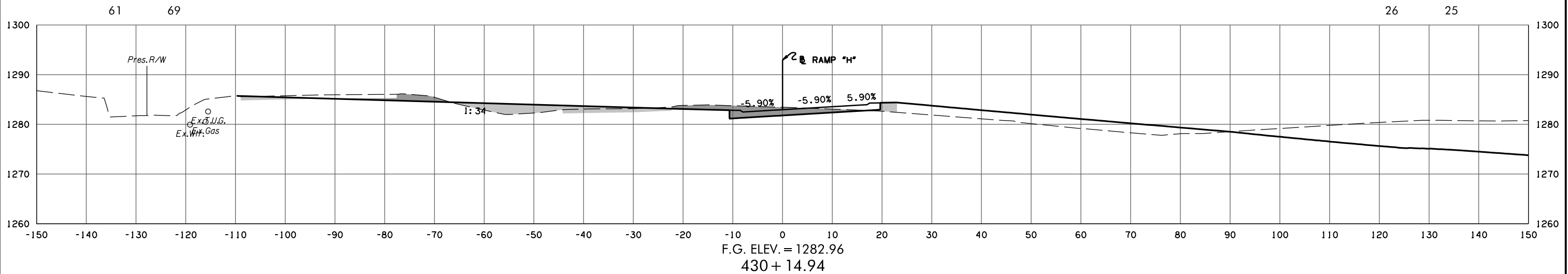

RAMP H PHASE 4
 STATE JOB NO. 09032(08)
 OKLAHOMA COUNTY SHEET NO. X203

3/4/2024 3:58:33 PM H:\PROJECTS\2789_CrossRoads_Phase 4\Roadway\Drawings\Sections\0903208-XSEC_Ramp_H.dgn

(CAUTION) THE LOCATION OF ALL UTILITIES AS SHOWN ARE APPROXIMATE. DUE TO RELOCATION'S PLANNED OR PRESENTLY UNDER CONSTRUCTION THERE ARE SOME UTILITIES THAT WILL BE RELOCATED AND NOT SHOWN ON THESE PLANS. THE CONTRACTOR SHALL BE RESPONSIBLE FOR ANY DAMAGE TO ALL UTILITIES.
 DEPTH & LOCATION OF EXISTING UTILITIES SHALL BE FIELD VERIFIED BY THE CONTRACTOR PRIOR TO CONSTRUCTION.

SEE DRAINAGE AREA MAP SHEETS FOR DRAINAGE SYMBOLOLOGY.

R/W & U/E PURCHASED UNDER JP 09032(05)

POB & ASSOCIATES, OKLAHOMA CITY, OK.
90% PLAN SUBMITTAL
 3/4/2024

AREA
 CUT FILL

VOLUME
 CUT FILL

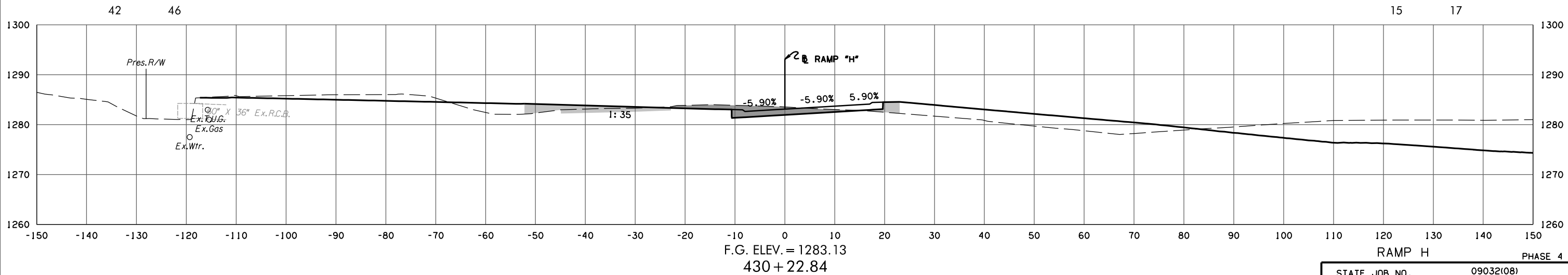
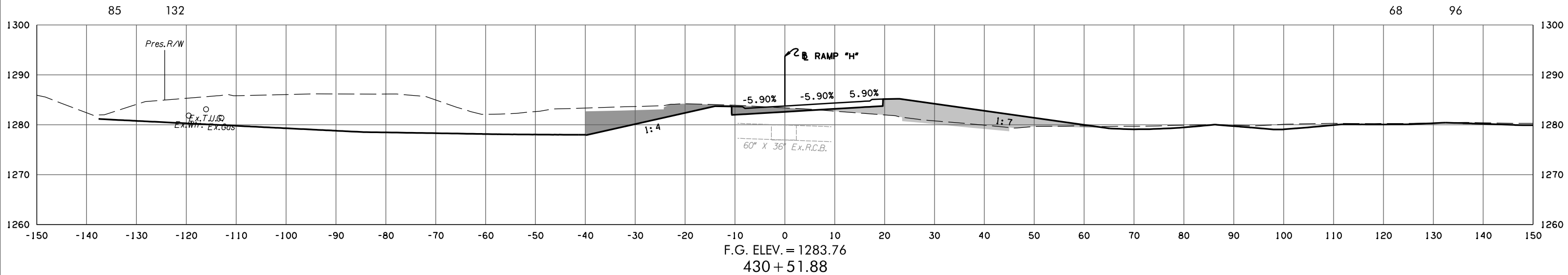
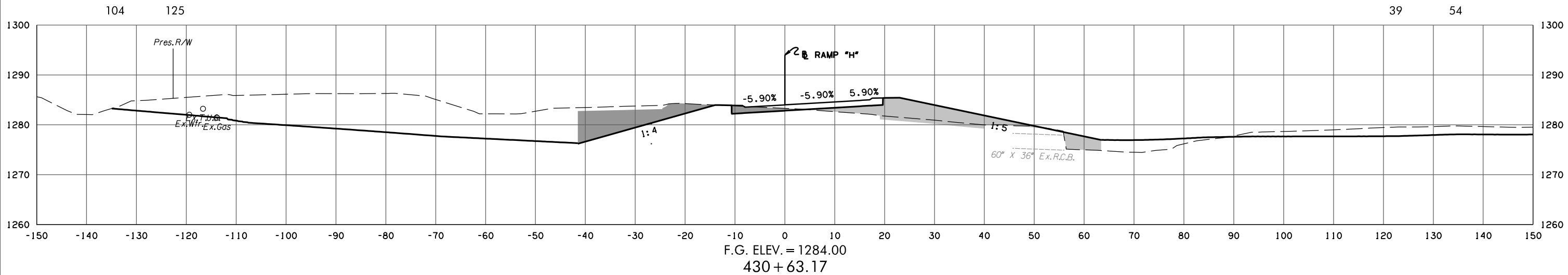

3/4/2024 3:58:35 PM H:\PROJECTS\2789_CrossRoads_Phase 4\Roadway\Drawings\Sections\0903208-XSEC_Ramp_H.dgn

STATE JOB NO. 09032(08)
 OKLAHOMA COUNTY SHEET NO. X204

(CAUTION) THE LOCATION OF ALL UTILITIES AS SHOWN ARE APPROXIMATE. DUE TO RELOCATION'S PLANNED OR PRESENTLY UNDER CONSTRUCTION THERE ARE SOME UTILITIES THAT WILL BE RELOCATED AND NOT SHOWN ON THESE PLANS. THE CONTRACTOR SHALL BE RESPONSIBLE FOR ANY DAMAGE TO ALL UTILITIES.
 DEPTH & LOCATION OF EXISTING UTILITIES SHALL BE FIELD VERIFIED BY THE CONTRACTOR PRIOR TO CONSTRUCTION.

SEE DRAINAGE AREA MAP SHEETS FOR DRAINAGE SYMBOLOLOGY.

R/W & U/E PURCHASED UNDER JP 09032(05)

POB & ASSOCIATES, OKLAHOMA CITY, OK.
90% PLAN SUBMITTAL
 3/4/2024

AREA
 CUT FILL

VOLUME
 CUT FILL

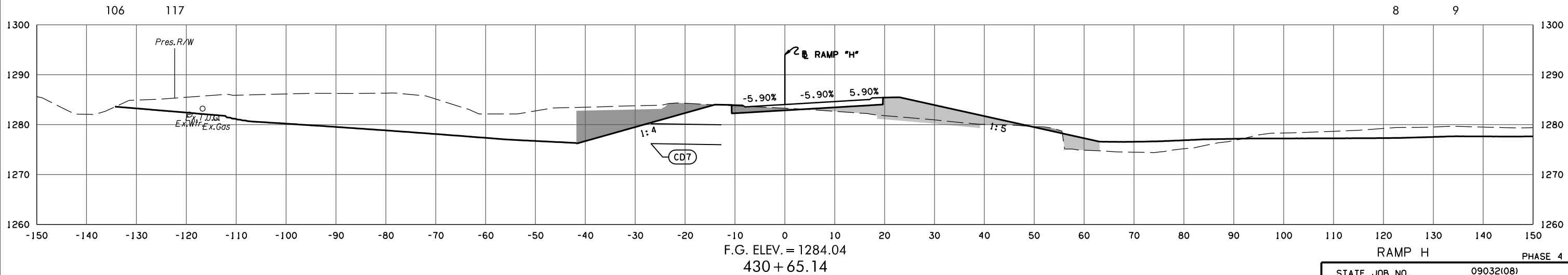
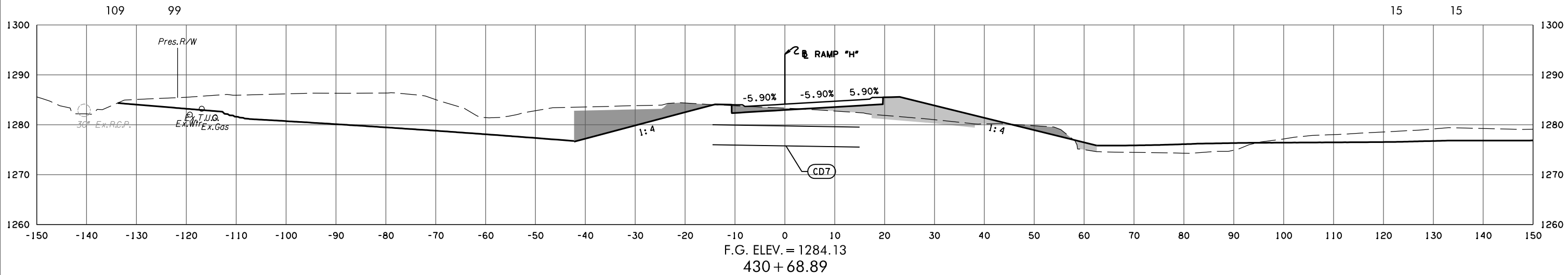
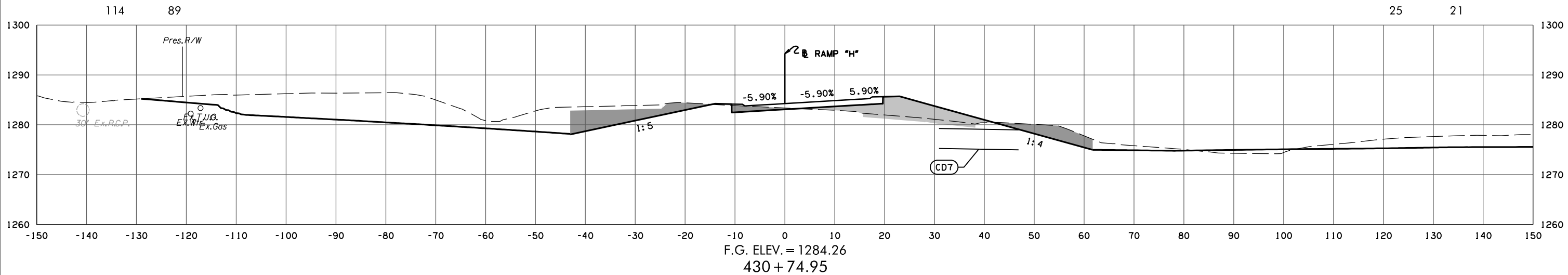

3/4/2024 3:58:36 PM H:\PROJECTS\2789_CrossRoads_Phase 4\Roadway\Drawings\Sections\0903208-XSEC_Ramp_H.dgn

STATE JOB NO. 09032(08)
 OKLAHOMA COUNTY SHEET NO. X205

RAMP H PHASE 4

(CAUTION) THE LOCATION OF ALL UTILITIES AS SHOWN ARE APPROXIMATE. DUE TO RELOCATION'S PLANNED OR PRESENTLY UNDER CONSTRUCTION THERE ARE SOME UTILITIES THAT WILL BE RELOCATED AND NOT SHOWN ON THESE PLANS. THE CONTRACTOR SHALL BE RESPONSIBLE FOR ANY DAMAGE TO ALL UTILITIES.

SEE DRAINAGE AREA MAP SHEETS FOR DRAINAGE SYMBOLOLOGY.

R/W & U/E PURCHASED UNDER JP 09032(05)

POB & ASSOCIATES, OKLAHOMA CITY, OK.

**90% PLAN
SUBMITTAL**

3/4/2024

DEPTH & LOCATION OF EXISTING UTILITIES SHALL BE FIELD VERIFIED BY THE CONTRACTOR PRIOR TO CONSTRUCTION.

AREA
CUT FILL

VOLUME
CUT FILL

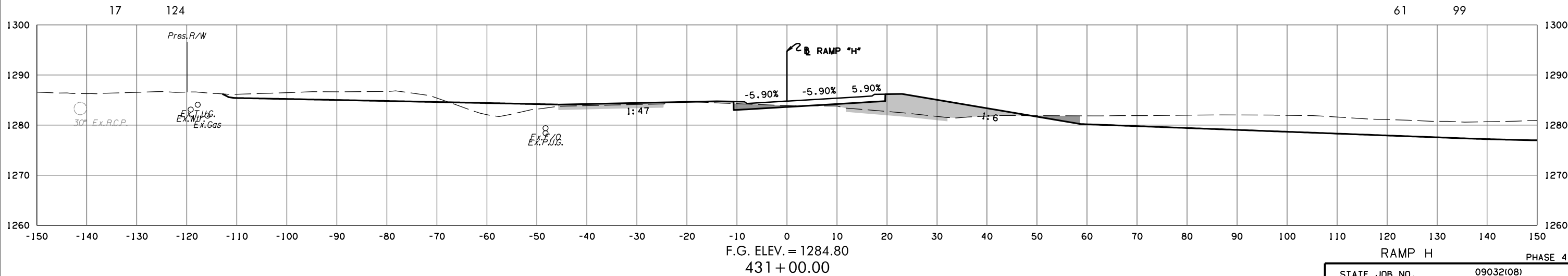
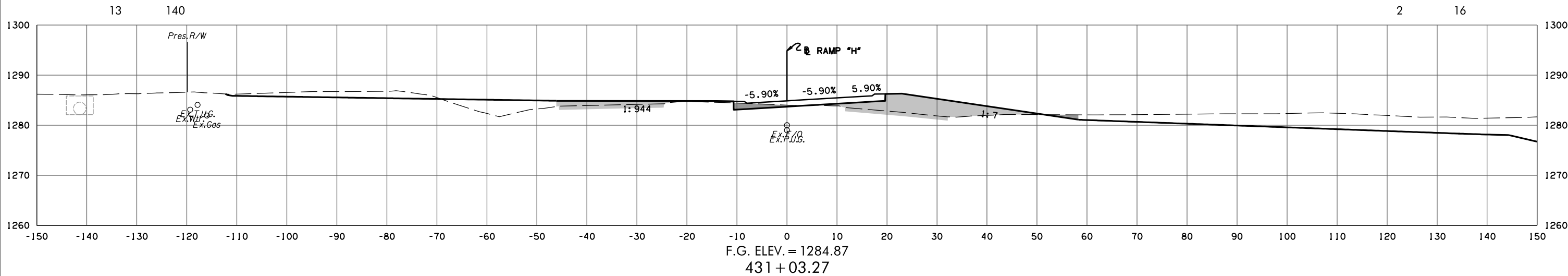
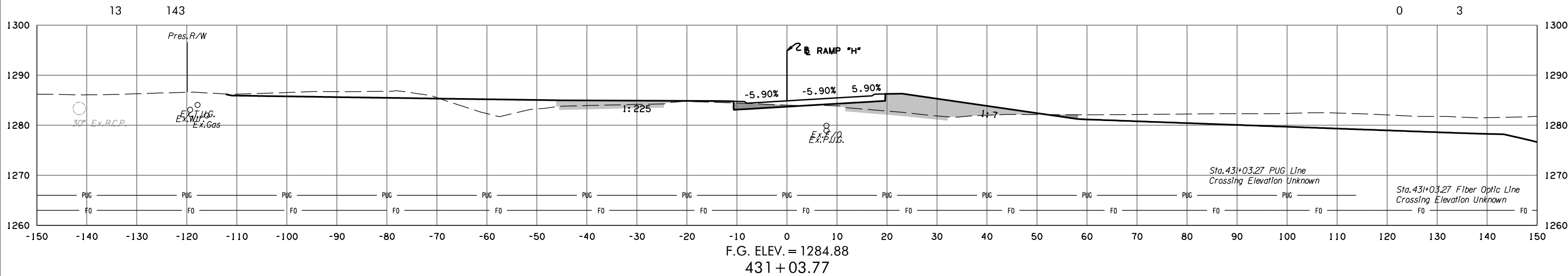

3/4/2024 3:58:37 PM H:\PROJECTS\2789_CrossRoads_Phase 4\Roadway\Drawings\Sections\0903208-XSEC_Ramp_H.dgn

(CAUTION) THE LOCATION OF ALL UTILITIES AS SHOWN ARE APPROXIMATE. DUE TO RELOCATION'S PLANNED OR PRESENTLY UNDER CONSTRUCTION THERE ARE SOME UTILITIES THAT WILL BE RELOCATED AND NOT SHOWN ON THESE PLANS. THE CONTRACTOR SHALL BE RESPONSIBLE FOR ANY DAMAGE TO ALL UTILITIES.

SEE DRAINAGE AREA MAP SHEETS FOR DRAINAGE SYMBOLOLOGY.

R/W & U/E PURCHASED UNDER JP 09032(05)

POB & ASSOCIATES, OKLAHOMA CITY, OK.

90% PLAN SUBMITTAL

3/4/2024

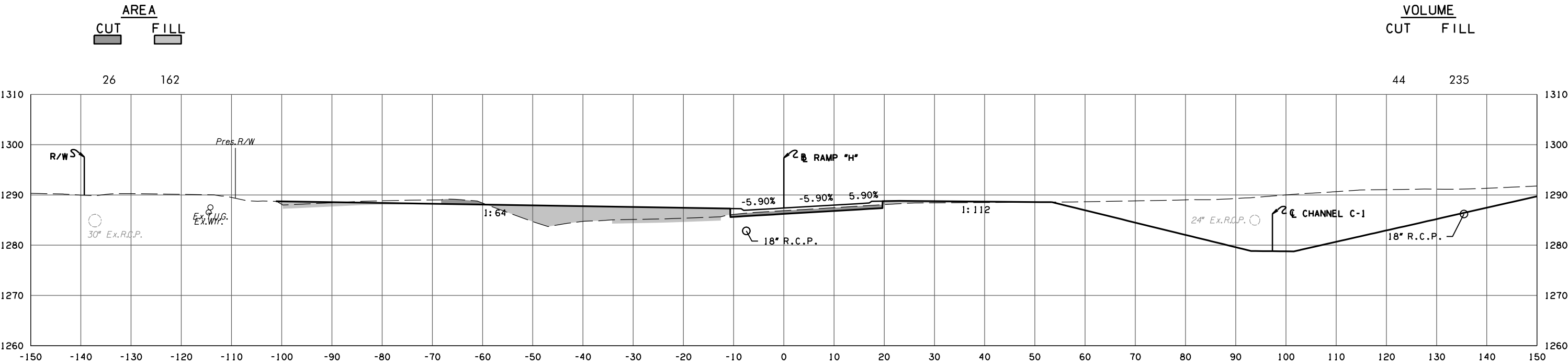

F.G. ELEV. = 1287.39
432 + 38.13

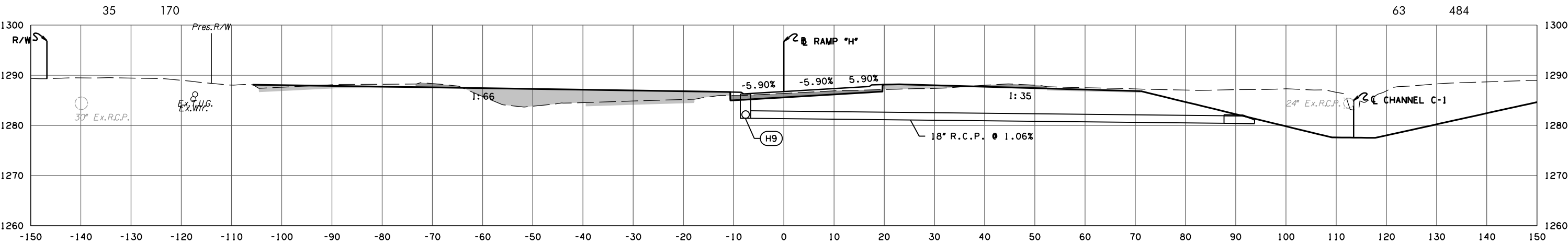

F.G. ELEV. = 1286.75
432 + 00.00

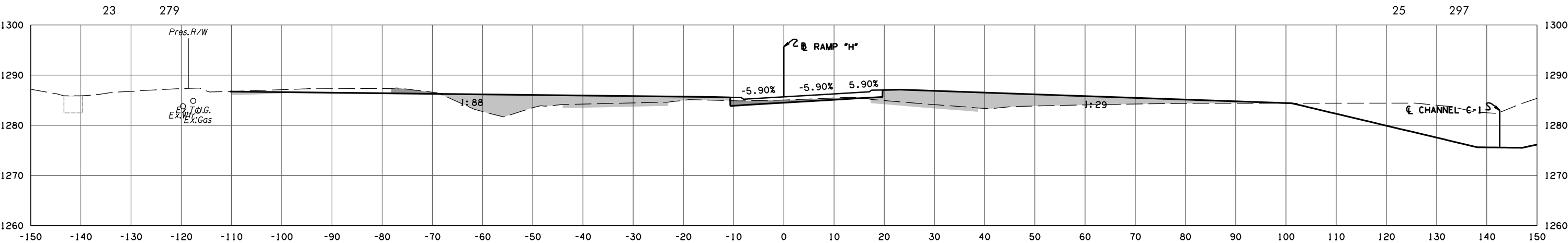

F.G. ELEV. = 1285.67
431 + 41.82

RAMP H PHASE 4

STATE JOB NO.	09032(08)
OKLAHOMA COUNTY	SHEET NO. X207

3/4/2024 3:58:38 PM
H:\PROJECTS\2789_CrossRoads_Phase 4\Roadway\Drawings\Sections\0903208-XSEC_Ramp_H.dgn

(CAUTION) THE LOCATION OF ALL UTILITIES AS SHOWN ARE APPROXIMATE. DUE TO RELOCATION'S PLANNED OR PRESENTLY UNDER CONSTRUCTION THERE ARE SOME UTILITIES THAT WILL BE RELOCATED AND NOT SHOWN ON THESE PLANS. THE CONTRACTOR SHALL BE RESPONSIBLE FOR ANY DAMAGE TO ALL UTILITIES.
 DEPTH & LOCATION OF EXISTING UTILITIES SHALL BE FIELD VERIFIED BY THE CONTRACTOR PRIOR TO CONSTRUCTION.

SEE DRAINAGE AREA MAP SHEETS FOR DRAINAGE SYMBOLOLOGY.

R/W & U/E PURCHASED UNDER JP 09032(05)

POB & ASSOCIATES, OKLAHOMA CITY, OK.
90% PLAN SUBMITTAL
 3/4/2024

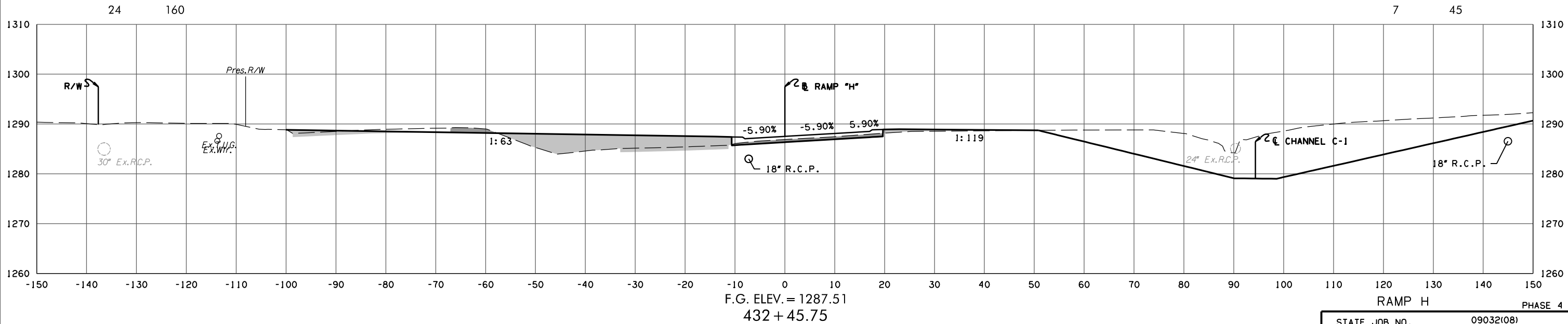
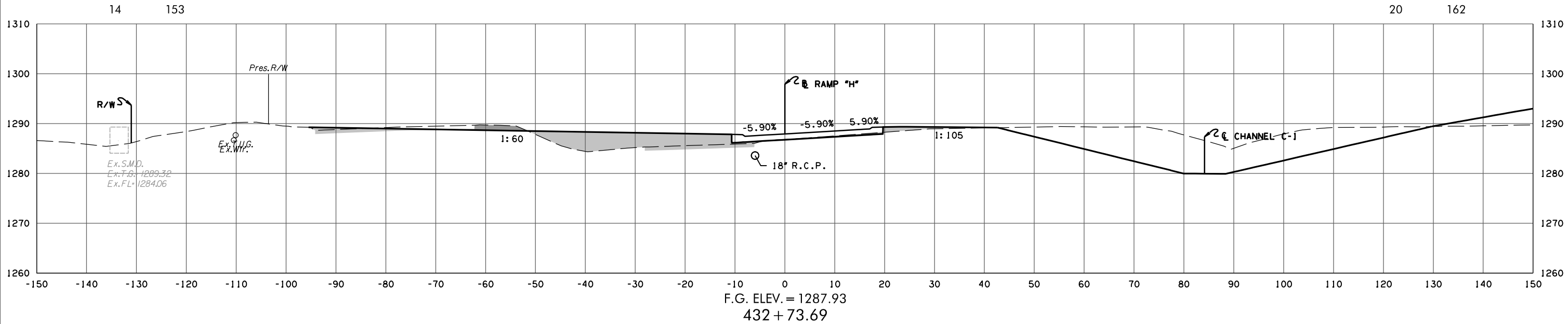
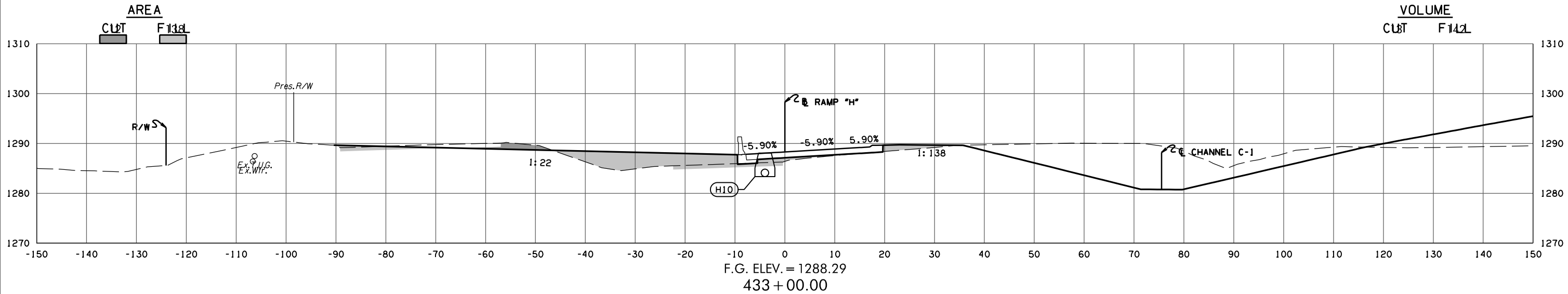

RAMP H PHASE 4
 STATE JOB NO. 09032(08)
 OKLAHOMA COUNTY SHEET NO. X208

3/4/2024 3:58:39 PM H:\PROJECTS\2789_CrossRoads_Phase 4\Roadway\Drawings\Sections\0903208-XSEC_Ramp_H.dgn

(CAUTION) THE LOCATION OF ALL UTILITIES AS SHOWN ARE APPROXIMATE. DUE TO RELOCATION'S PLANNED OR PRESENTLY UNDER CONSTRUCTION THERE ARE SOME UTILITIES THAT WILL BE RELOCATED AND NOT SHOWN ON THESE PLANS. THE CONTRACTOR SHALL BE RESPONSIBLE FOR ANY DAMAGE TO ALL UTILITIES.

DEPTH & LOCATION OF EXISTING UTILITIES SHALL BE FIELD VERIFIED BY THE CONTRACTOR PRIOR TO CONSTRUCTION.

SEE DRAINAGE AREA MAP SHEETS FOR DRAINAGE SYMBOLOLOGY.

R/W & U/E PURCHASED UNDER JP 09032(05)

POE & ASSOCIATES, OKLAHOMA CITY, OK.

90% PLAN SUBMITTAL

3/4/2024

AREA
CUT FILL

VOLUME
CUT FILL

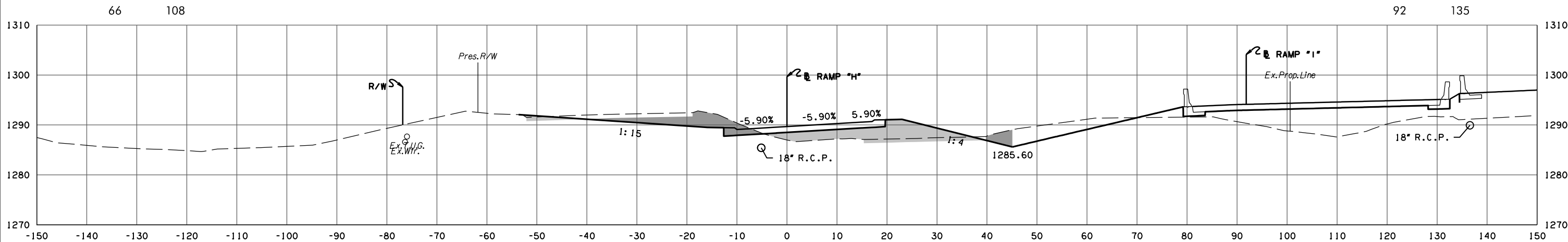

F.G. ELEV. = 1289.68
434 + 32.00

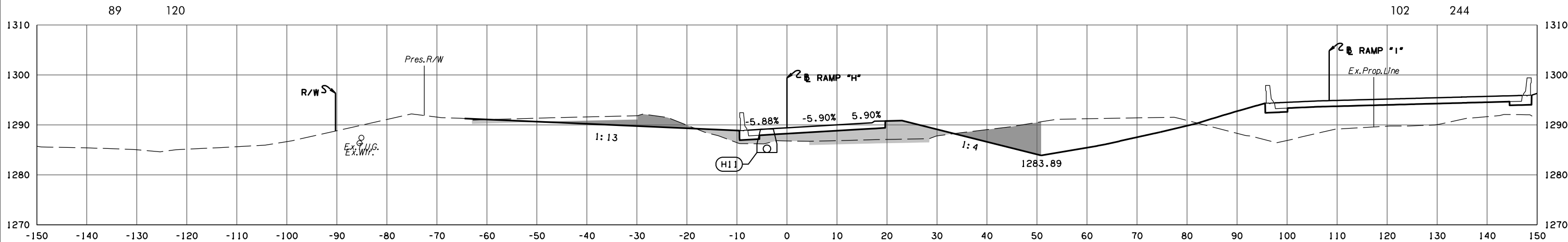

F.G. ELEV. = 1289.41
434 + 00.00

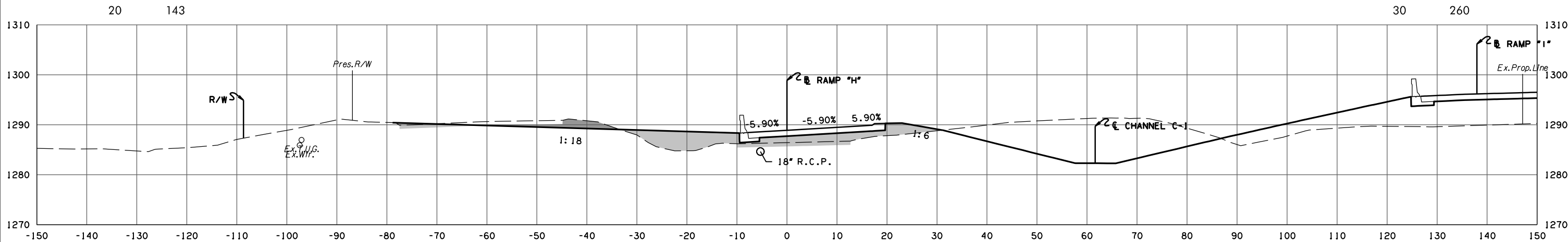

F.G. ELEV. = 1288.90
433 + 50.00

RAMP H PHASE 4

STATE JOB NO. 09032(08)
OKLAHOMA COUNTY SHEET NO. X209

3/4/2024 3:58:40 PM H:\PROJECTS\2789_CrossRoads_Phase 4\Roadway\Drawings\Sections\0903208-XSEC_Ramp_H.dgn

(CAUTION) THE LOCATION OF ALL UTILITIES AS SHOWN ARE APPROXIMATE. DUE TO RELOCATION'S PLANNED OR PRESENTLY UNDER CONSTRUCTION THERE ARE SOME UTILITIES THAT WILL BE RELOCATED AND NOT SHOWN ON THESE PLANS. THE CONTRACTOR SHALL BE RESPONSIBLE FOR ANY DAMAGE TO ALL UTILITIES.
 DEPTH & LOCATION OF EXISTING UTILITIES SHALL BE FIELD VERIFIED BY THE CONTRACTOR PRIOR TO CONSTRUCTION.

SEE DRAINAGE AREA MAP SHEETS FOR DRAINAGE SYMBOLOLOGY.

R/W & U/E PURCHASED UNDER JP 09032(05)

POB & ASSOCIATES, OKLAHOMA CITY, OK.
90% PLAN SUBMITTAL
 3/4/2024

AREA
 CUT FILL

VOLUME
 CUT FILL

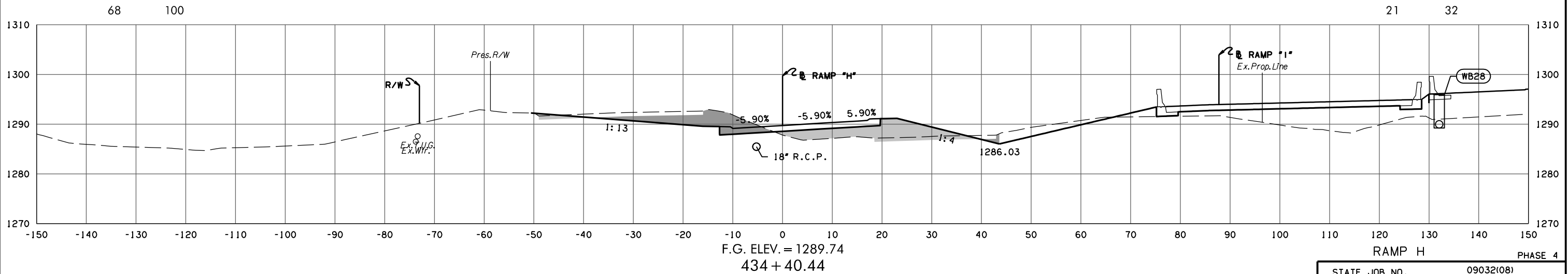
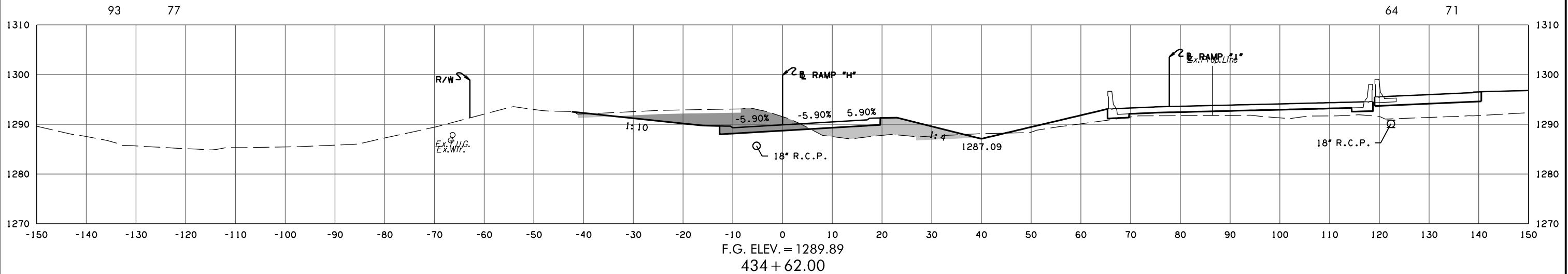
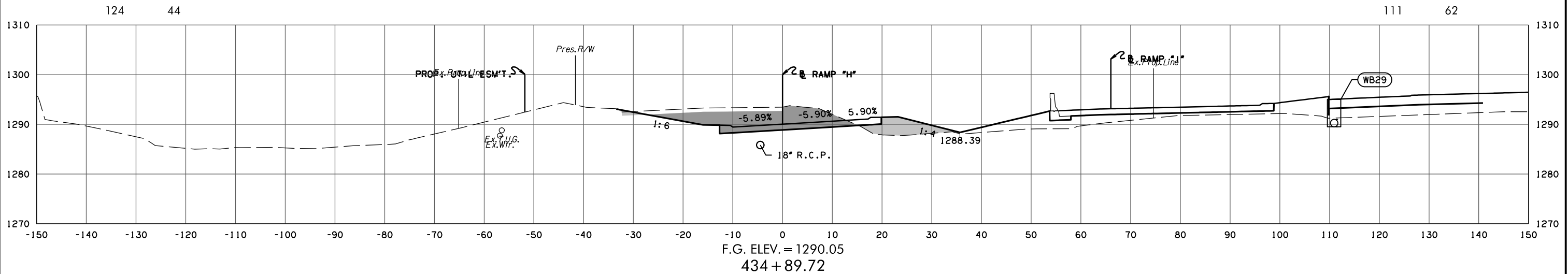

STATE JOB NO. 09032(08)
 OKLAHOMA COUNTY SHEET NO. X210

3/4/2024 3:58:41 PM H:\PROJECTS\2789_CrossRoads_Phase 4\Roadway\Drawings\Sections\0903208-XSEC_Ramp_H.dgn

(CAUTION) THE LOCATION OF ALL UTILITIES AS SHOWN ARE APPROXIMATE. DUE TO RELOCATION'S PLANNED OR PRESENTLY UNDER CONSTRUCTION THERE ARE SOME UTILITIES THAT WILL BE RELOCATED AND NOT SHOWN ON THESE PLANS. THE CONTRACTOR SHALL BE RESPONSIBLE FOR ANY DAMAGE TO ALL UTILITIES.
 DEPTH & LOCATION OF EXISTING UTILITIES SHALL BE FIELD VERIFIED BY THE CONTRACTOR PRIOR TO CONSTRUCTION.

SEE DRAINAGE AREA MAP SHEETS FOR DRAINAGE SYMBOLOLOGY.

R/W & U/E PURCHASED UNDER JP 09032(05)

POE & ASSOCIATES, OKLAHOMA CITY, OK.

90% PLAN SUBMITTAL

3/4/2024

AREA
 CUT FILL

VOLUME
 CUT FILL

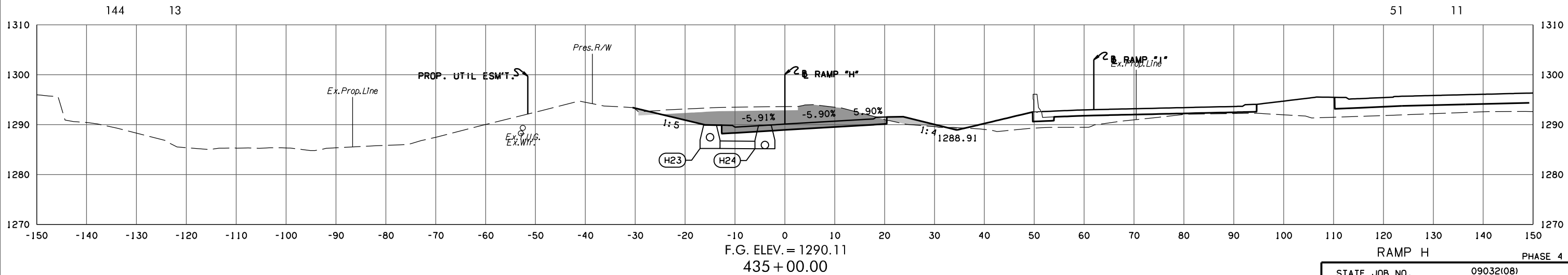
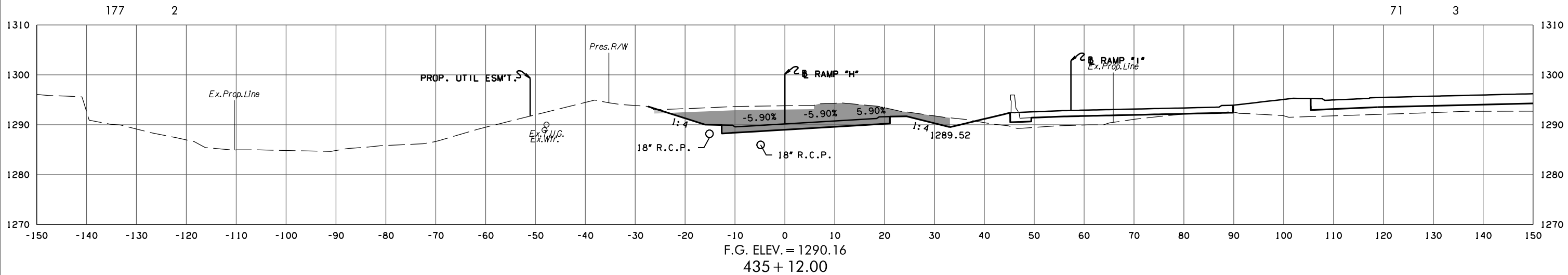
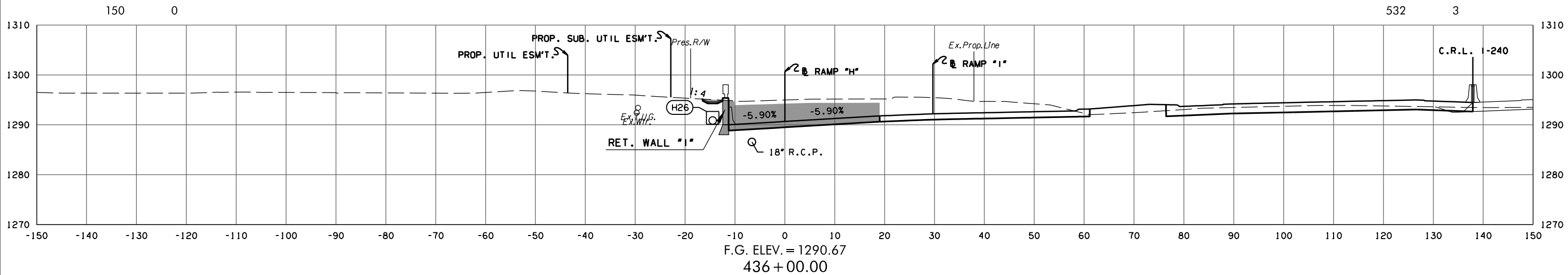

3/4/2024 3:58:42 PM H:\PROJECTS\2789_CrossRoads_Phase 4\Roadway\Drawings\Sections\0903208-XSEC_Ramp_H.dgn

(CAUTION) THE LOCATION OF ALL UTILITIES AS SHOWN ARE APPROXIMATE. DUE TO RELOCATION'S PLANNED OR PRESENTLY UNDER CONSTRUCTION THERE ARE SOME UTILITIES THAT WILL BE RELOCATED AND NOT SHOWN ON THESE PLANS. THE CONTRACTOR SHALL BE RESPONSIBLE FOR ANY DAMAGE TO ALL UTILITIES.
 DEPTH & LOCATION OF EXISTING UTILITIES SHALL BE FIELD VERIFIED BY THE CONTRACTOR PRIOR TO CONSTRUCTION.

SEE DRAINAGE AREA MAP SHEETS FOR DRAINAGE SYMBOLLOGY.

R/W & U/E PURCHASED UNDER JP 09032(05)

POB & ASSOCIATES, OKLAHOMA CITY, OK.

90% PLAN SUBMITTAL

3/4/2024

AREA
 CUT FILL

VOLUME
 CUT FILL

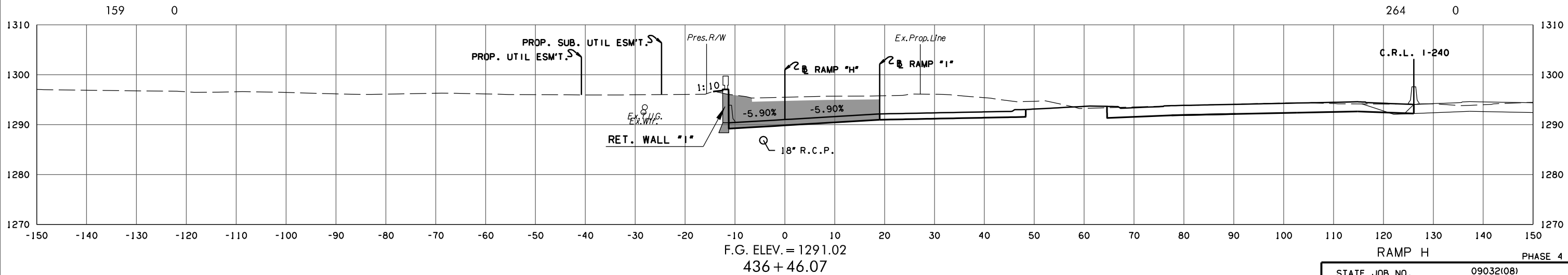
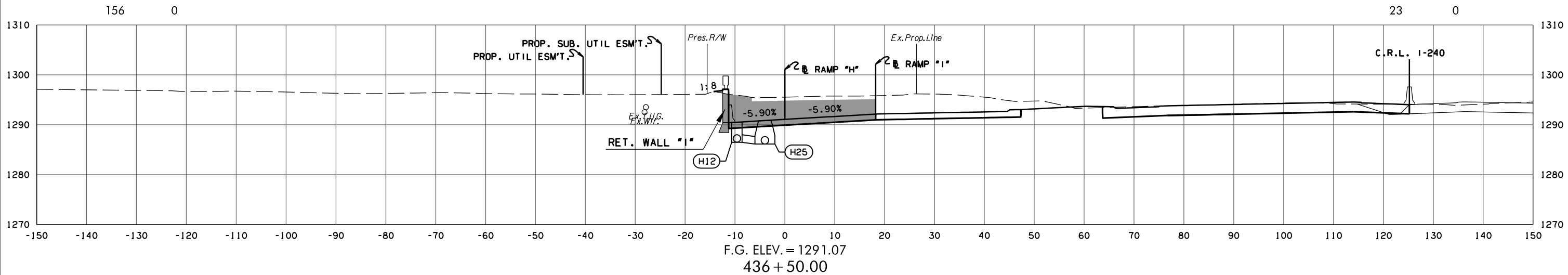
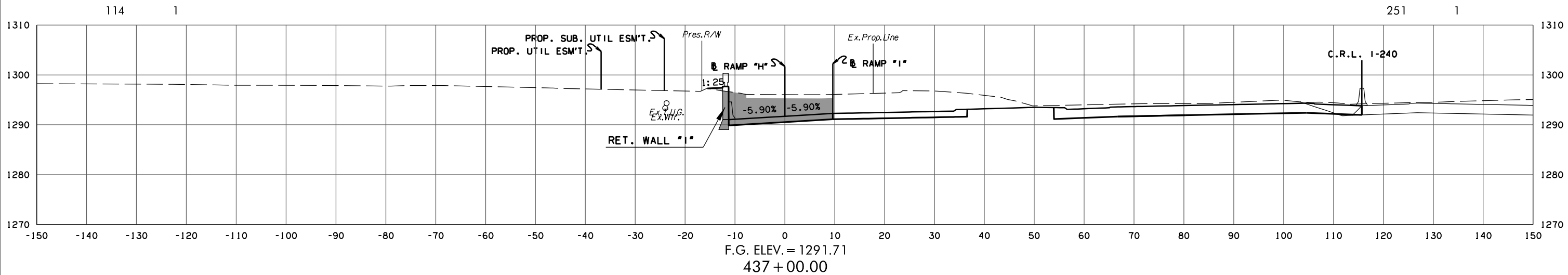

RAMP H PHASE 4
 STATE JOB NO. 09032(08)
 OKLAHOMA COUNTY SHEET NO. X212

3/4/2024 3:58:43 PM H:\PROJECTS\2789_CrossRoads_Phase 4\Roadway\Drawings\Sections\0903208-XSEC_Ramp_H.dgn

(CAUTION) THE LOCATION OF ALL UTILITIES AS SHOWN ARE APPROXIMATE. DUE TO RELOCATION'S PLANNED OR PRESENTLY UNDER CONSTRUCTION THERE ARE SOME UTILITIES THAT WILL BE RELOCATED AND NOT SHOWN ON THESE PLANS. THE CONTRACTOR SHALL BE RESPONSIBLE FOR ANY DAMAGE TO ALL UTILITIES.

DEPTH & LOCATION OF EXISTING UTILITIES SHALL BE FIELD VERIFIED BY THE CONTRACTOR PRIOR TO CONSTRUCTION.

SEE DRAINAGE AREA MAP SHEETS FOR DRAINAGE SYMBOLOLOGY.

R/W & U/E PURCHASED UNDER JP 09032(05)

POB & ASSOCIATES, OKLAHOMA CITY, OK.

**90% PLAN
SUBMITTAL**

3/4/2024

AREA

CUT	FILL
71	10

VOLUME

CUT	FILL
159	12

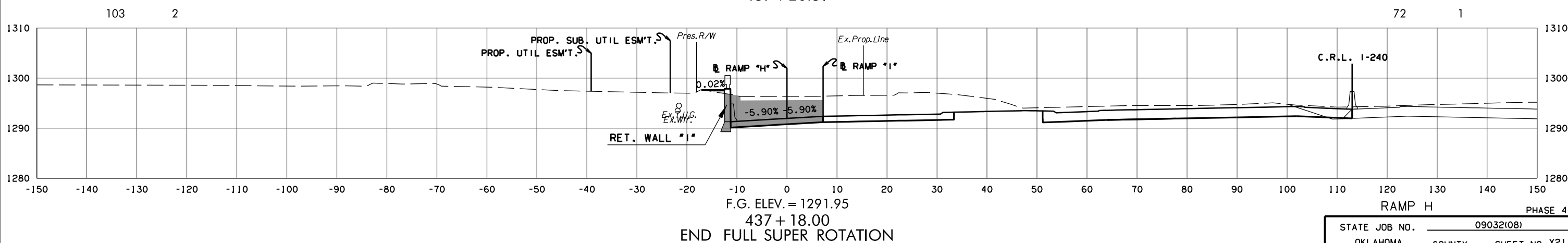
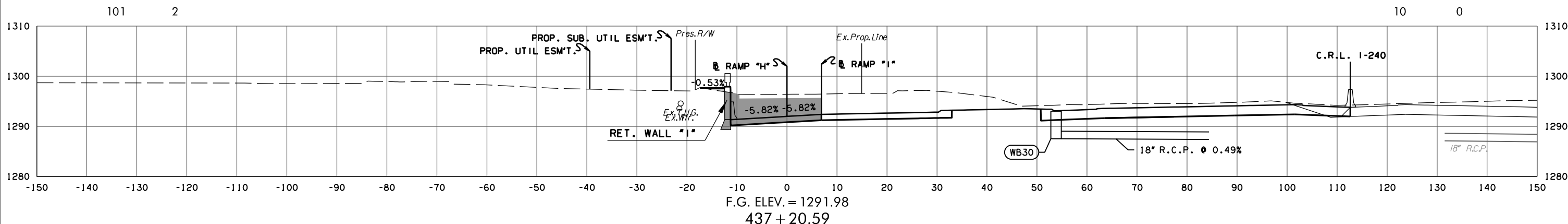
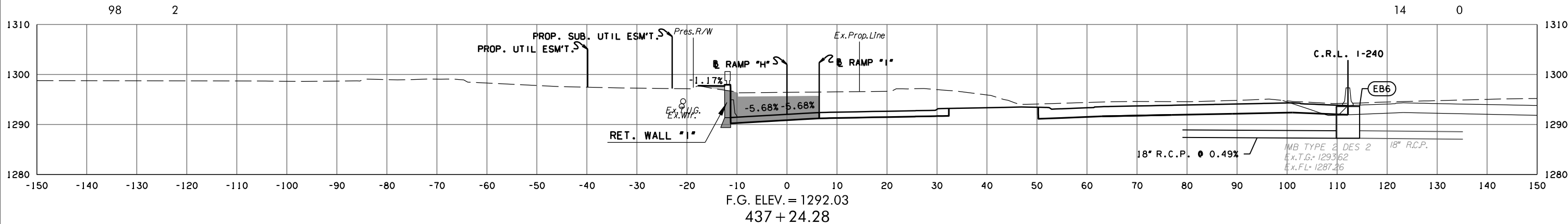
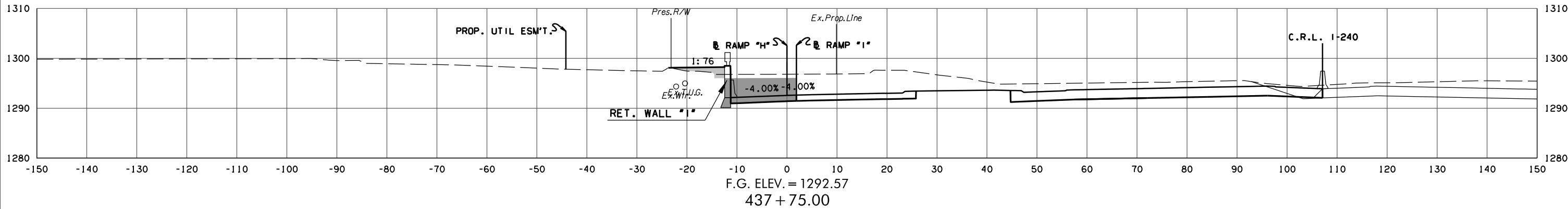

3/4/2024 3:58:44 PM H:\PROJECTS\2789_CrossRoads_Phase 4\Roadway\Drawings\Sections\0903208-XSEC_Ramp_H.dgn

(CAUTION) THE LOCATION OF ALL UTILITIES AS SHOWN ARE APPROXIMATE. DUE TO RELOCATION'S PLANNED OR PRESENTLY UNDER CONSTRUCTION THERE ARE SOME UTILITIES THAT WILL BE RELOCATED AND NOT SHOWN ON THESE PLANS. THE CONTRACTOR SHALL BE RESPONSIBLE FOR ANY DAMAGE TO ALL UTILITIES.

DEPTH & LOCATION OF EXISTING UTILITIES SHALL BE FIELD VERIFIED BY THE CONTRACTOR PRIOR TO CONSTRUCTION.

SEE DRAINAGE AREA MAP SHEETS FOR DRAINAGE SYMBOLOLOGY.

R/W & U/E PURCHASED UNDER JP 09032(05)

POB & ASSOCIATES, OKLAHOMA CITY, OK.

**90% PLAN
SUBMITTAL**

3/4/2024

AREA
CUT FILL

VOLUME
CUT FILL

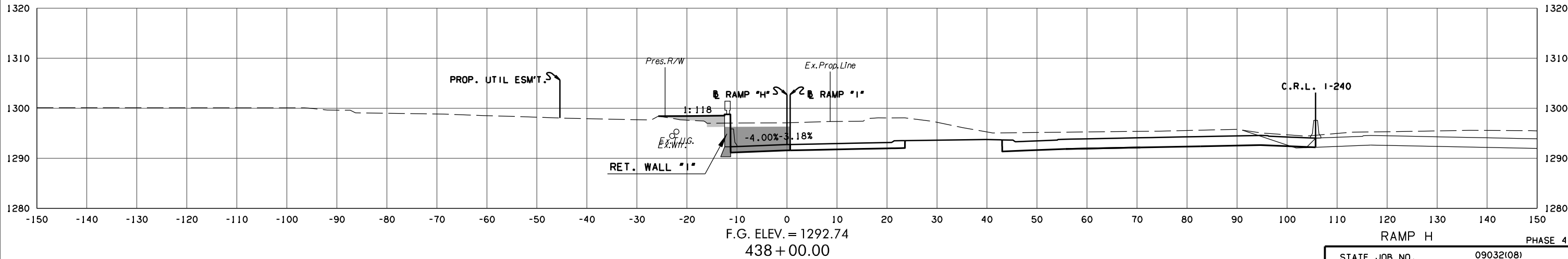
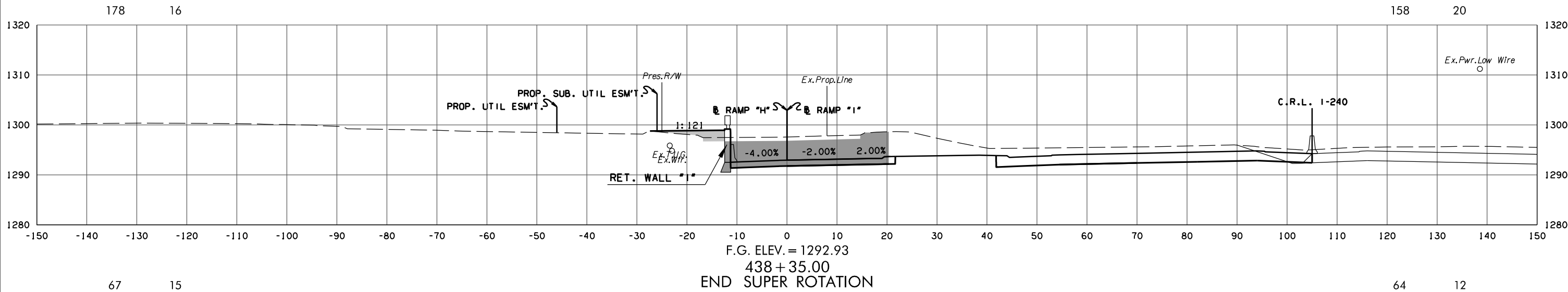
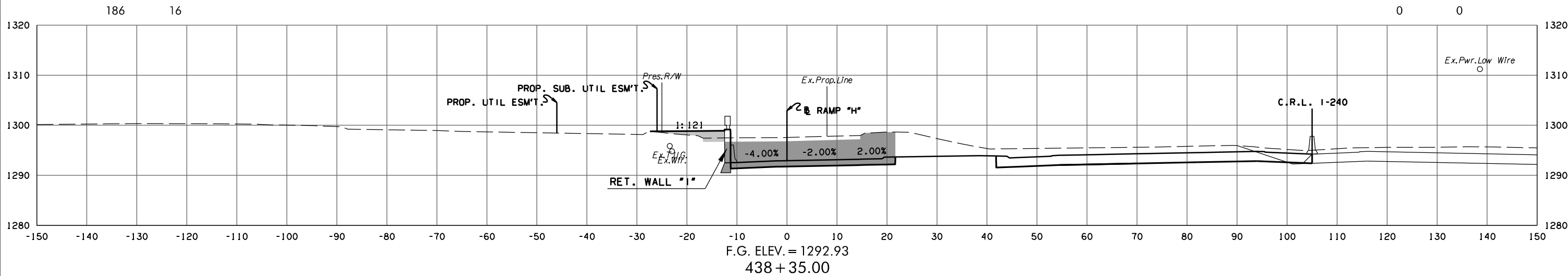

STATE JOB NO. 09032(08)
OKLAHOMA COUNTY SHEET NO. X214

3/4/2024 3:58:46 PM H:\PROJECTS\2789_CrossRoads_Phase 4\Roadway\Drawings\Sections\0903208-XSEC_Ramp_H.dgn

(CAUTION) THE LOCATION OF ALL UTILITIES AS SHOWN ARE APPROXIMATE. DUE TO RELOCATION'S PLANNED OR PRESENTLY UNDER CONSTRUCTION THERE ARE SOME UTILITIES THAT WILL BE RELOCATED AND NOT SHOWN ON THESE PLANS. THE CONTRACTOR SHALL BE RESPONSIBLE FOR ANY DAMAGE TO ALL UTILITIES.
 DEPTH & LOCATION OF EXISTING UTILITIES SHALL BE FIELD VERIFIED BY THE CONTRACTOR PRIOR TO CONSTRUCTION.

SEE DRAINAGE AREA MAP SHEETS FOR DRAINAGE SYMBOLOLOGY.

R/W & U/E PURCHASED UNDER JP 09032(05)

POB & ASSOCIATES, OKLAHOMA CITY, OK.
90% PLAN SUBMITTAL
 3/4/2024

AREA
 CUT FILL

VOLUME
 CUT FILL

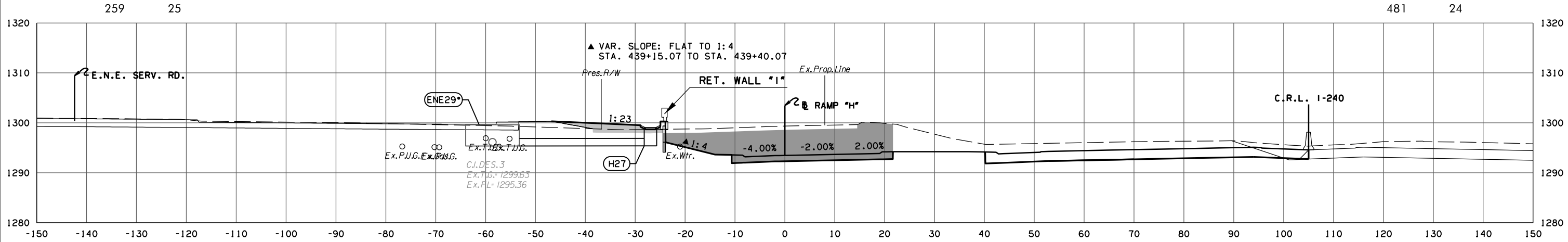

F.G. ELEV. = 1293.48
 439 + 51.08

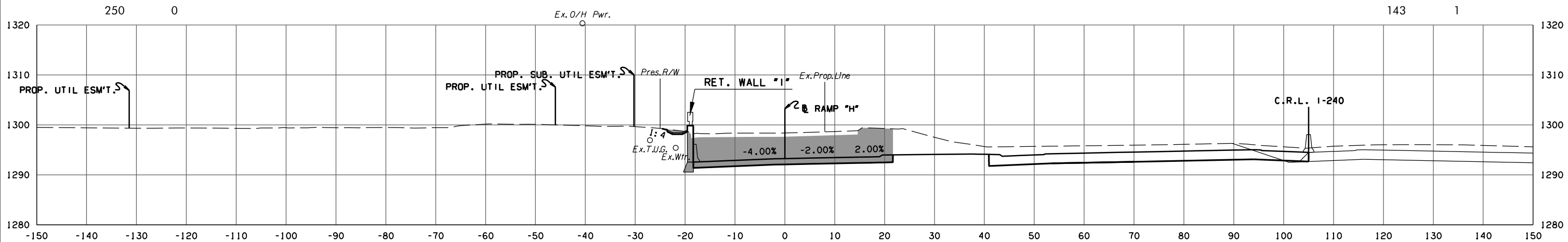

F.G. ELEV. = 1293.24
 439 + 00.00

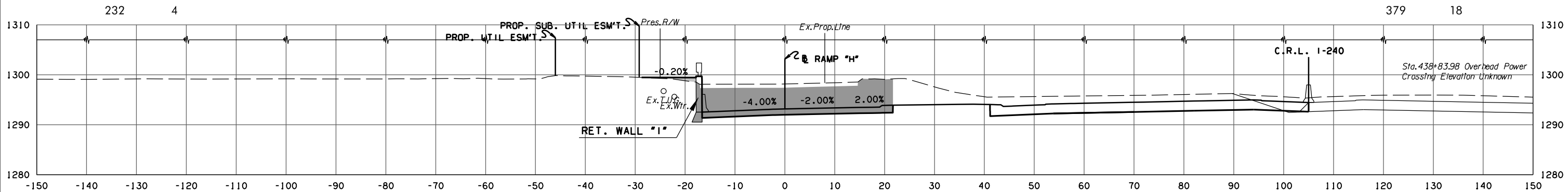

F.G. ELEV. = 1293.16
 438 + 83.98

RAMP H PHASE 4

STATE JOB NO. 09032(08)
 OKLAHOMA COUNTY SHEET NO. X215

3/4/2024 3:58:47 PM H:\PROJECTS\2789_CrossRoads_Phase 4\Roadway\Drawings\Sections\0903208-XSEC_Ramp_H.dgn

(CAUTION) THE LOCATION OF ALL UTILITIES AS SHOWN ARE APPROXIMATE. DUE TO RELOCATION'S PLANNED OR PRESENTLY UNDER CONSTRUCTION THERE ARE SOME UTILITIES THAT WILL BE RELOCATED AND NOT SHOWN ON THESE PLANS. THE CONTRACTOR SHALL BE RESPONSIBLE FOR ANY DAMAGE TO ALL UTILITIES.
 DEPTH & LOCATION OF EXISTING UTILITIES SHALL BE FIELD VERIFIED BY THE CONTRACTOR PRIOR TO CONSTRUCTION.

SEE DRAINAGE AREA MAP SHEETS FOR DRAINAGE SYMBOLOLOGY.

R/W & U/E PURCHASED UNDER JP 09032(05)

POB & ASSOCIATES, OKLAHOMA CITY, OK.
90% PLAN SUBMITTAL
 3/4/2024

AREA
 CUT FILL

VOLUME
 CUT FILL

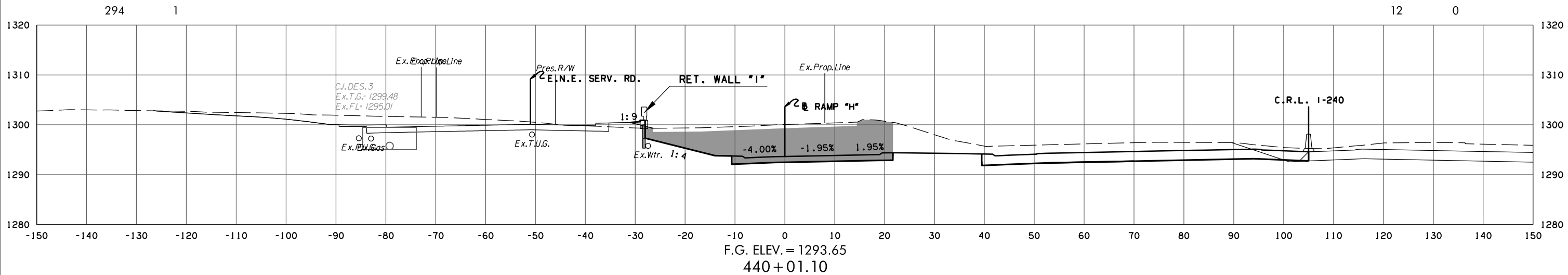

F.G. ELEV. = 1293.65
 440+01.10

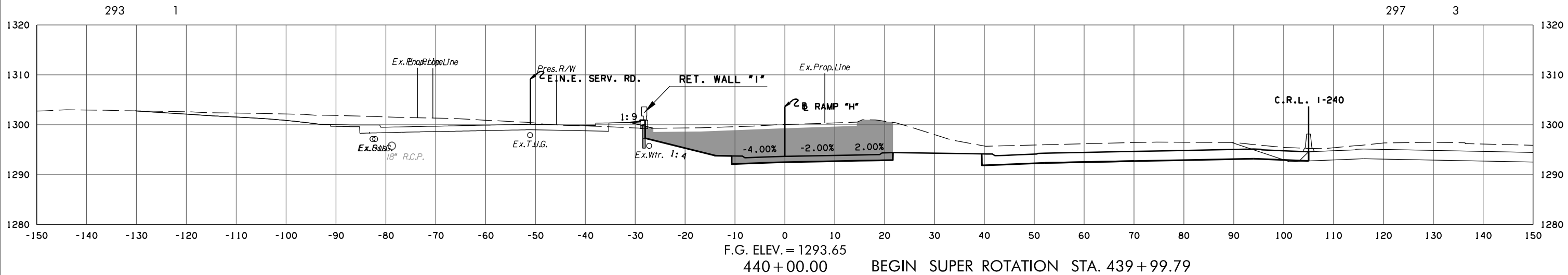

F.G. ELEV. = 1293.65
 440+00.00

BEGIN SUPER ROTATION STA. 439+99.79

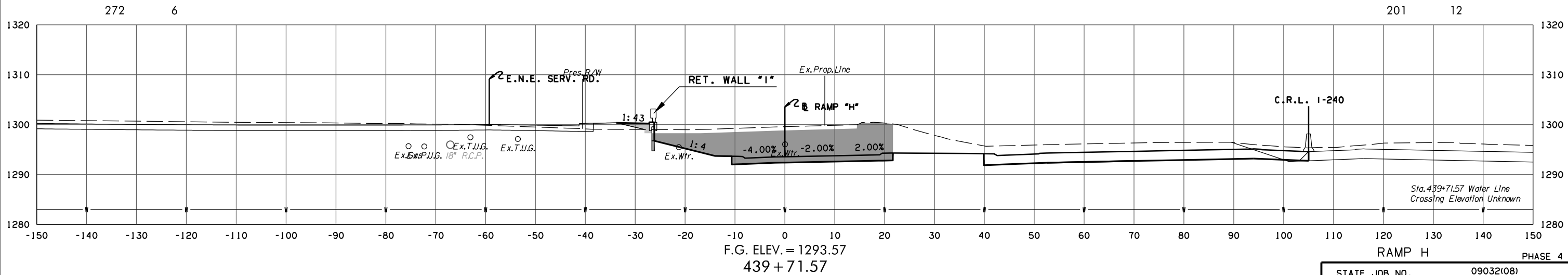

F.G. ELEV. = 1293.57
 439+71.57

RAMP H PHASE 4

STATE JOB NO. 09032(08)
 OKLAHOMA COUNTY SHEET NO. X216

3/4/2024 3:58:48 PM H:\PROJECTS\2789_CrossRoads_Phase 4\Roadway\Drawings\Sections\0903208-XSEC_Ramp_H.dgn

(CAUTION) THE LOCATION OF ALL UTILITIES AS SHOWN ARE APPROXIMATE. DUE TO RELOCATION'S PLANNED OR PRESENTLY UNDER CONSTRUCTION THERE ARE SOME UTILITIES THAT WILL BE RELOCATED AND NOT SHOWN ON THESE PLANS. THE CONTRACTOR SHALL BE RESPONSIBLE FOR ANY DAMAGE TO ALL UTILITIES.
 DEPTH & LOCATION OF EXISTING UTILITIES SHALL BE FIELD VERIFIED BY THE CONTRACTOR PRIOR TO CONSTRUCTION.

SEE DRAINAGE AREA MAP SHEETS FOR DRAINAGE SYMBOLOLOGY.

R/W & U/E PURCHASED UNDER JP 09032(05)

POB & ASSOCIATES, OKLAHOMA CITY, OK.

90% PLAN SUBMITTAL

3/4/2024

AREA
 CUT FILL

VOLUME
 CUT FILL

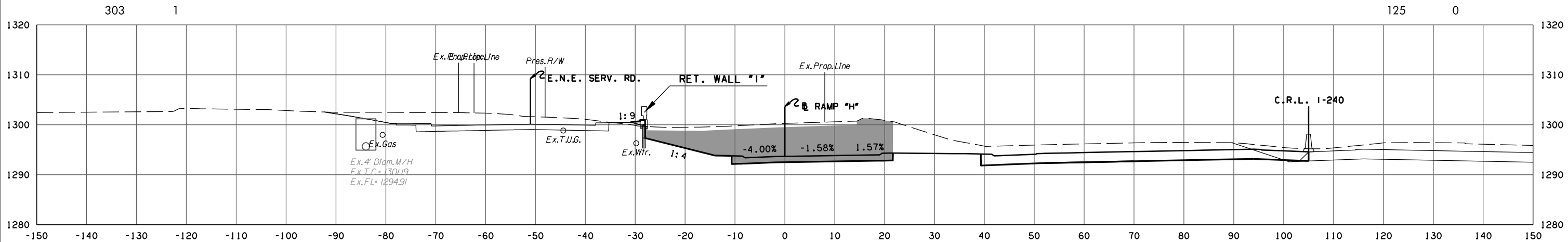
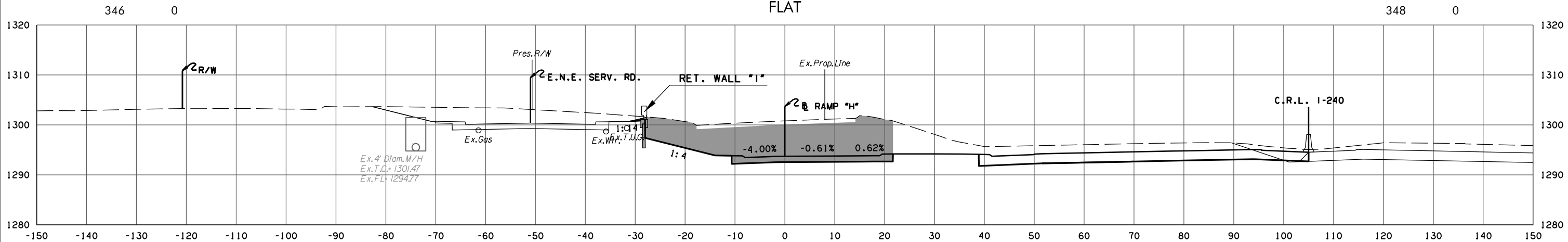
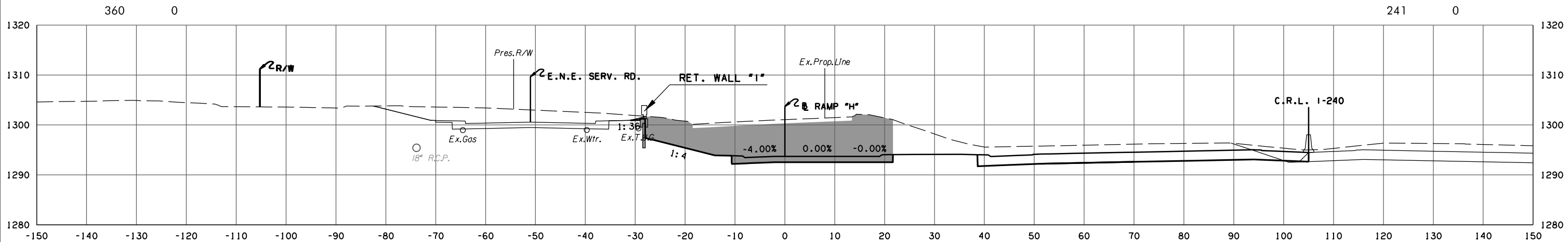

3/4/2024 3:58:49 PM H:\PROJECTS\2789_CrossRoads_Phase 4\Roadway\Drawings\Sections\0903208-XSEC_Ramp_H.dgn

(CAUTION) THE LOCATION OF ALL UTILITIES AS SHOWN ARE APPROXIMATE. DUE TO RELOCATION'S PLANNED OR PRESENTLY UNDER CONSTRUCTION THERE ARE SOME UTILITIES THAT WILL BE RELOCATED AND NOT SHOWN ON THESE PLANS. THE CONTRACTOR SHALL BE RESPONSIBLE FOR ANY DAMAGE TO ALL UTILITIES.
 DEPTH & LOCATION OF EXISTING UTILITIES SHALL BE FIELD VERIFIED BY THE CONTRACTOR PRIOR TO CONSTRUCTION.

SEE DRAINAGE AREA MAP SHEETS FOR DRAINAGE SYMBOLOLOGY.

R/W & U/E PURCHASED UNDER JP 09032(05)

POB & ASSOCIATES, OKLAHOMA CITY, OK.

90% PLAN SUBMITTAL

3/4/2024

AREA
 CUT FILL

VOLUME
 CUT FILL

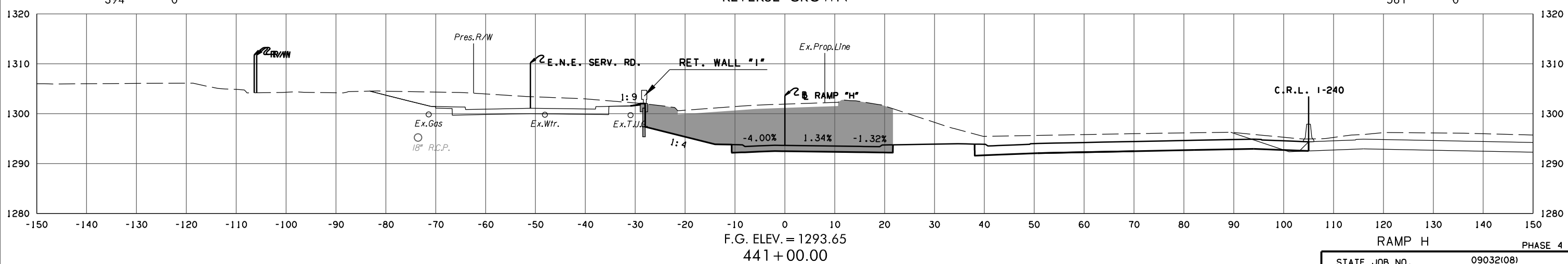
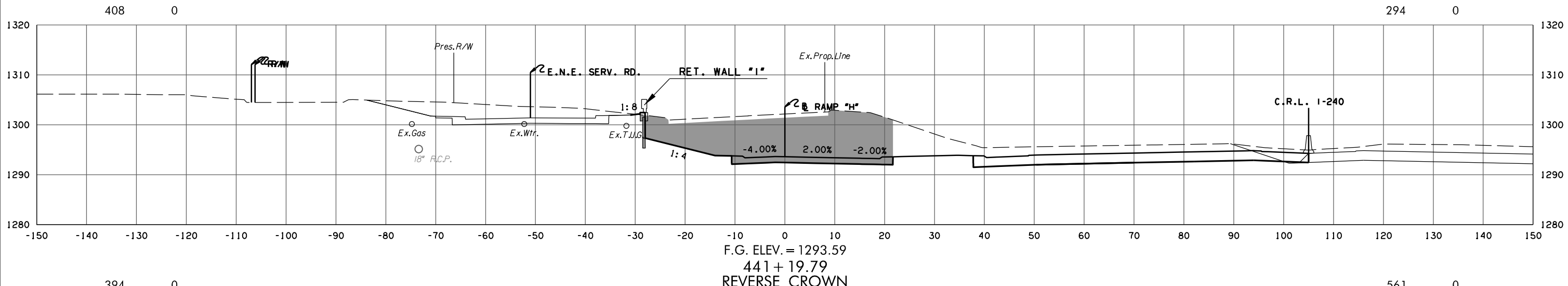
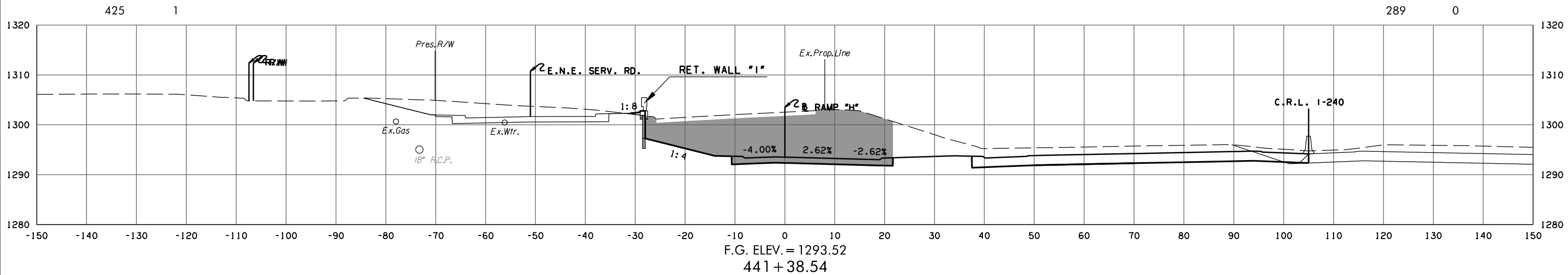

3/4/2024 3:58:50 PM H:\PROJECTS\2789_CrossRoads_Phase 4\Roadway\Drawings\Sections\0903208-XSEC_Ramp_H.dgn

(CAUTION) THE LOCATION OF ALL UTILITIES AS SHOWN ARE APPROXIMATE. DUE TO RELOCATION'S PLANNED OR PRESENTLY UNDER CONSTRUCTION THERE ARE SOME UTILITIES THAT WILL BE RELOCATED AND NOT SHOWN ON THESE PLANS. THE CONTRACTOR SHALL BE RESPONSIBLE FOR ANY DAMAGE TO ALL UTILITIES.

SEE DRAINAGE AREA MAP SHEETS FOR DRAINAGE SYMBOLOLOGY.

R/W & U/E PURCHASED UNDER JP 09032(05)

POE & ASSOCIATES, OKLAHOMA CITY, OK.

**90% PLAN
SUBMITTAL**

3/4/2024

DEPTH & LOCATION OF EXISTING UTILITIES SHALL BE FIELD VERIFIED BY THE CONTRACTOR PRIOR TO CONSTRUCTION.

AREA
CUT FILL

VOLUME
CUT FILL

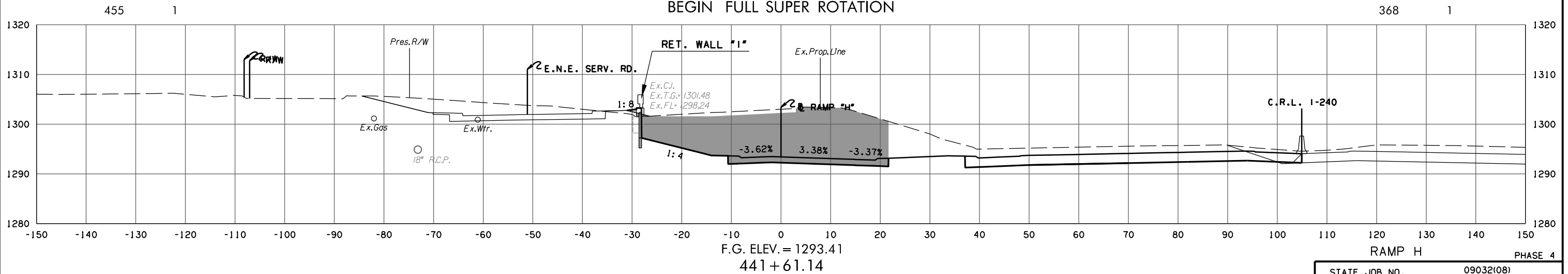
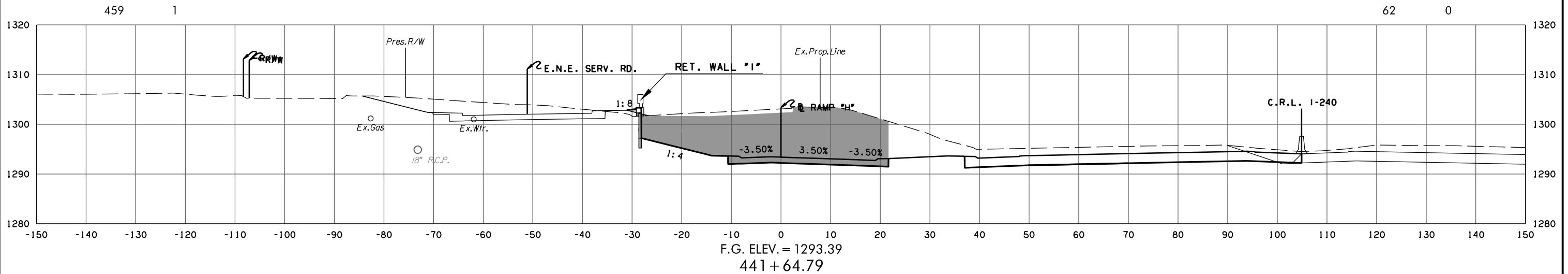
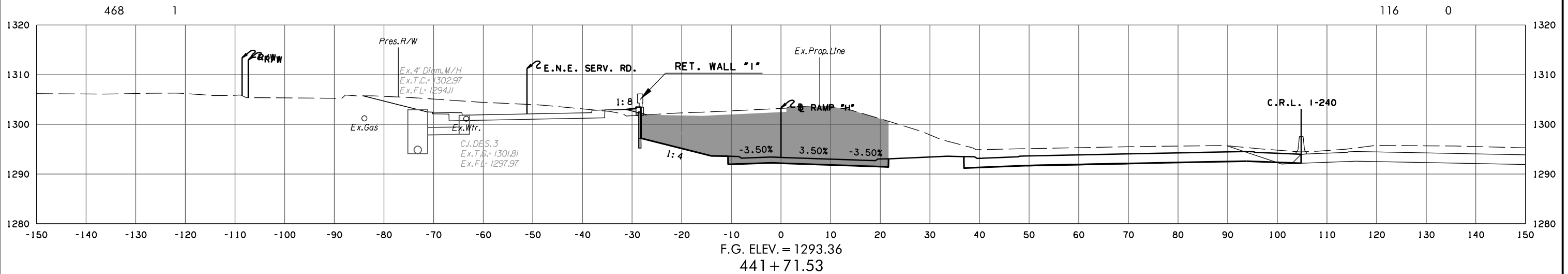

3/4/2024 3:58:51 PM H:\PROJECTS\2789_CrossRoads_Phase 4\Roadway\Drawings\Sections\0903208-XSEC_Ramp_H.dgn

[CAUTION] THE LOCATION OF ALL UTILITIES AS SHOWN ARE APPROXIMATE. DUE TO RELOCATION'S PLANNED OR PRESENTLY UNDER CONSTRUCTION THERE ARE SOME UTILITIES THAT WILL BE RELOCATED AND NOT SHOWN ON THESE PLANS. THE CONTRACTOR SHALL BE RESPONSIBLE FOR ANY DAMAGE TO ALL UTILITIES.

DEPTH & LOCATION OF EXISTING UTILITIES SHALL BE FIELD VERIFIED BY THE CONTRACTOR PRIOR TO CONSTRUCTION.

SEE DRAINAGE AREA MAP SHEETS FOR DRAINAGE SYMBOLOLOGY.

R/W & U/E PURCHASED UNDER JP 09032(05)

POE & ASSOCIATES, OKLAHOMA CITY, OK.

90% PLAN SUBMITTAL

3/4/2024

AREA
CUT FILL

VOLUME
CUT FILL

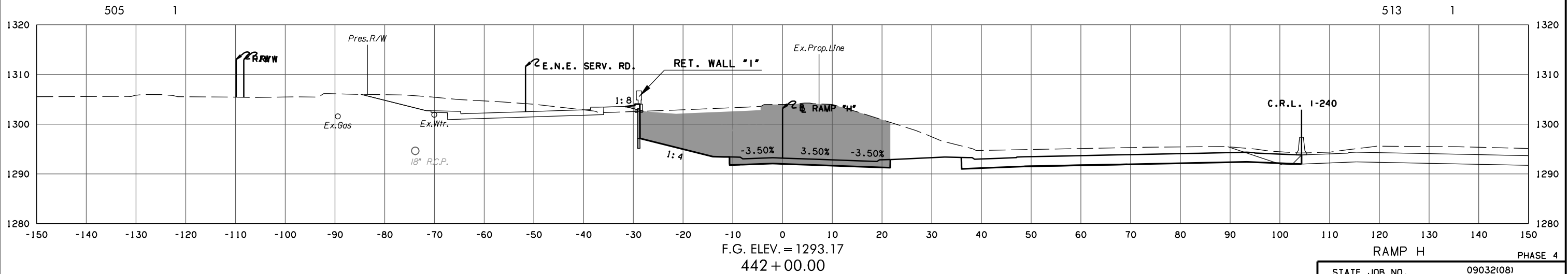
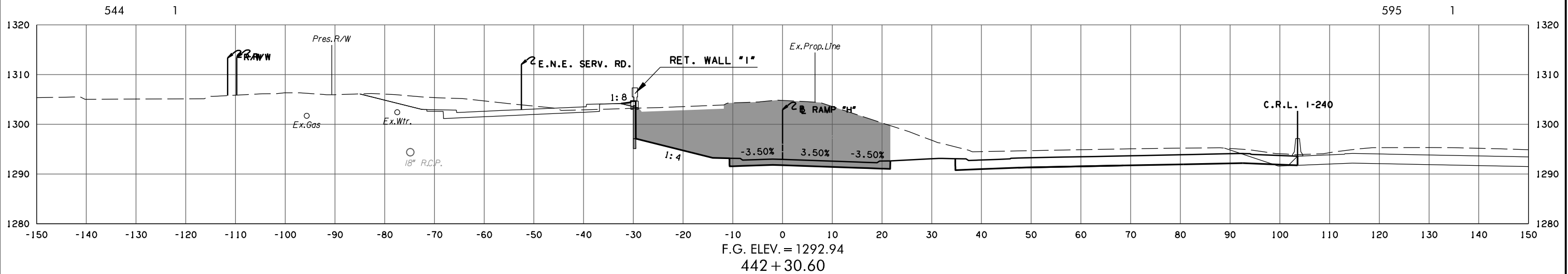
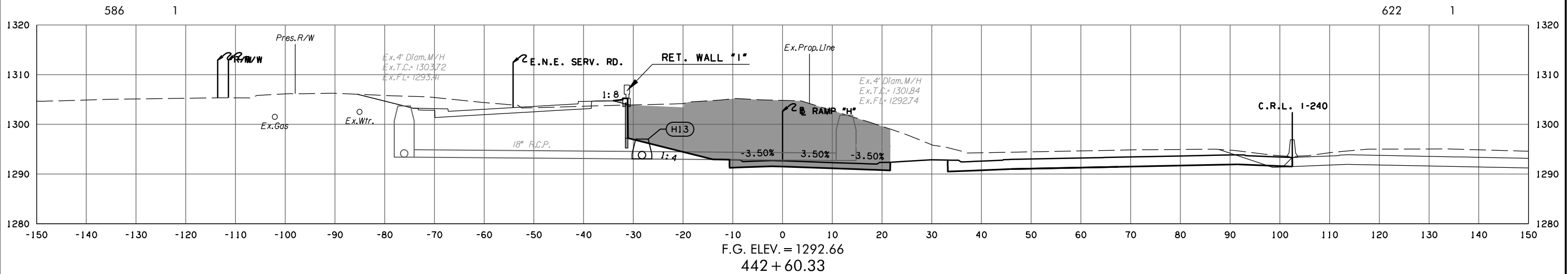

3/4/2024 3:58:52 PM H:\PROJECTS\2789_CrossRoads_Phase 4\Roadway\Drawings\Sections\0903208-XSEC_Ramp_H.dgn

(CAUTION) THE LOCATION OF ALL UTILITIES AS SHOWN ARE APPROXIMATE. DUE TO RELOCATION'S PLANNED OR PRESENTLY UNDER CONSTRUCTION THERE ARE SOME UTILITIES THAT WILL BE RELOCATED AND NOT SHOWN ON THESE PLANS. THE CONTRACTOR SHALL BE RESPONSIBLE FOR ANY DAMAGE TO ALL UTILITIES.
 DEPTH & LOCATION OF EXISTING UTILITIES SHALL BE FIELD VERIFIED BY THE CONTRACTOR PRIOR TO CONSTRUCTION.

SEE DRAINAGE AREA MAP SHEETS FOR DRAINAGE SYMBOLOLOGY.

R/W & U/E PURCHASED UNDER JP 09032(05)

POB & ASSOCIATES, OKLAHOMA CITY, OK.

90% PLAN SUBMITTAL

3/4/2024

AREA
 CUT FILL

VOLUME
 CUT FILL

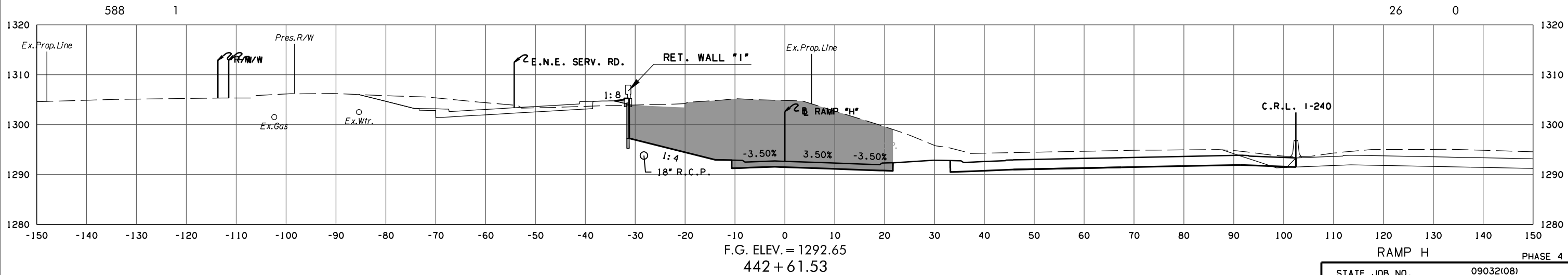
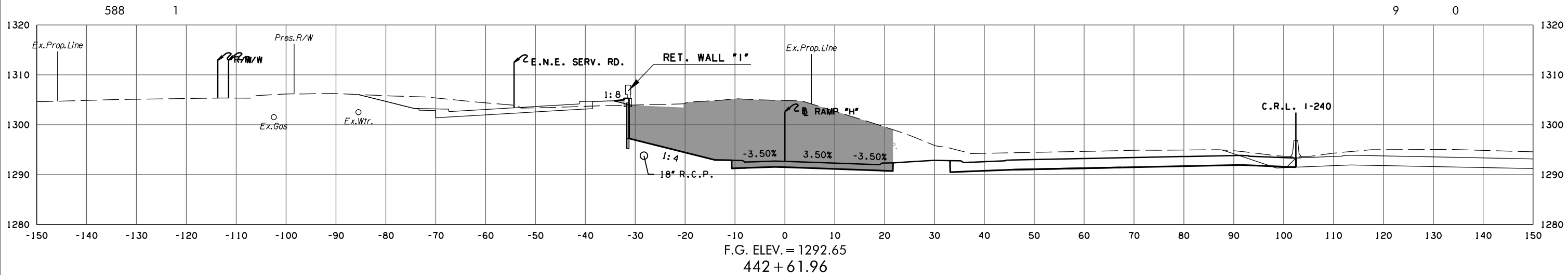
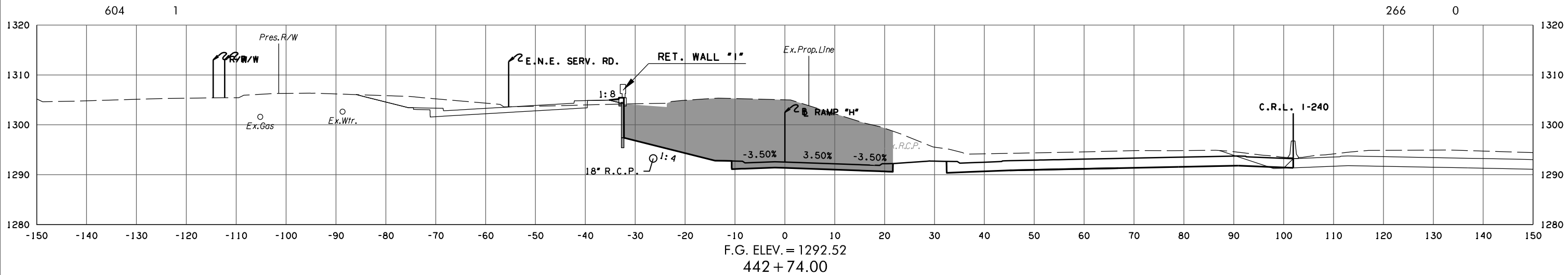

3/4/2024 3:58:53 PM
 H:\PROJECTS\2789_CrossRoads_Phase 4\Roadway\Drawings\Sections\0903208-XSEC_Ramp_H.dgn

(CAUTION) THE LOCATION OF ALL UTILITIES AS SHOWN ARE APPROXIMATE. DUE TO RELOCATION'S PLANNED OR PRESENTLY UNDER CONSTRUCTION THERE ARE SOME UTILITIES THAT WILL BE RELOCATED AND NOT SHOWN ON THESE PLANS. THE CONTRACTOR SHALL BE RESPONSIBLE FOR ANY DAMAGE TO ALL UTILITIES.
 DEPTH & LOCATION OF EXISTING UTILITIES SHALL BE FIELD VERIFIED BY THE CONTRACTOR PRIOR TO CONSTRUCTION.

SEE DRAINAGE AREA MAP SHEETS FOR DRAINAGE SYMBOLOLOGY.

R/W & U/E PURCHASED UNDER JP 09032(05)

POB & ASSOCIATES, OKLAHOMA CITY, OK.
90% PLAN SUBMITTAL
 3/4/2024

AREA
 CUT FILL

VOLUME
 CUT FILL

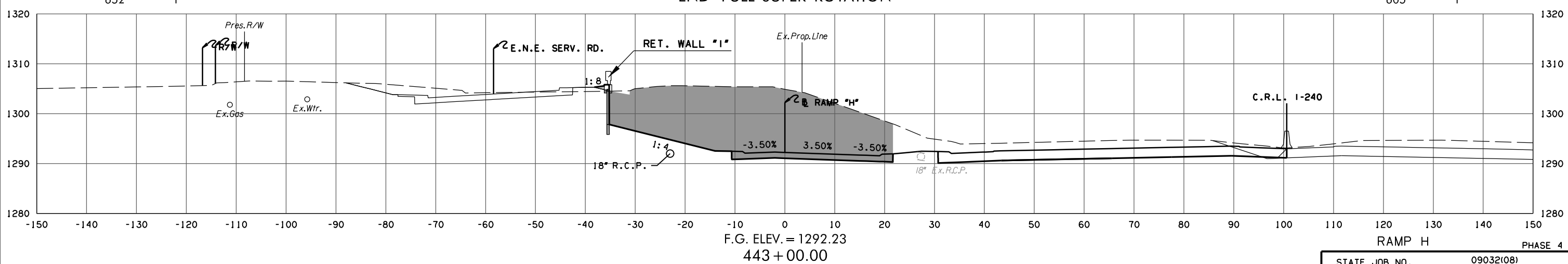
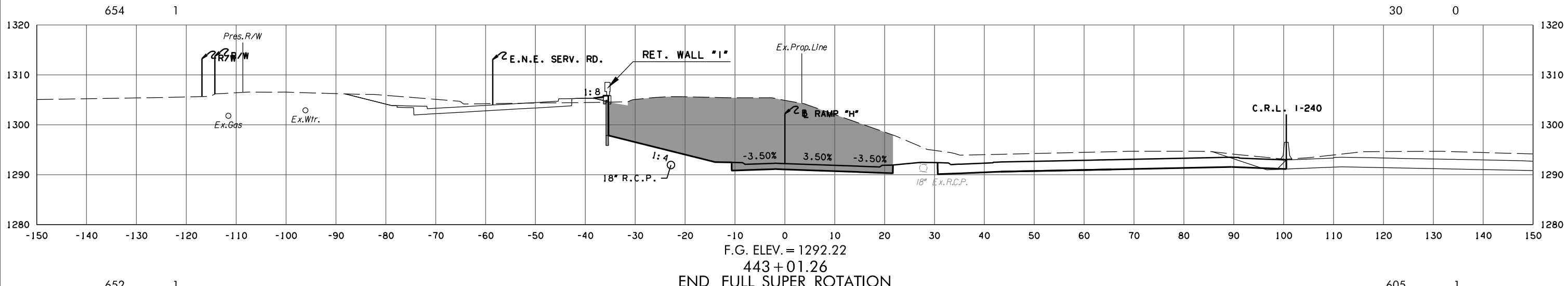
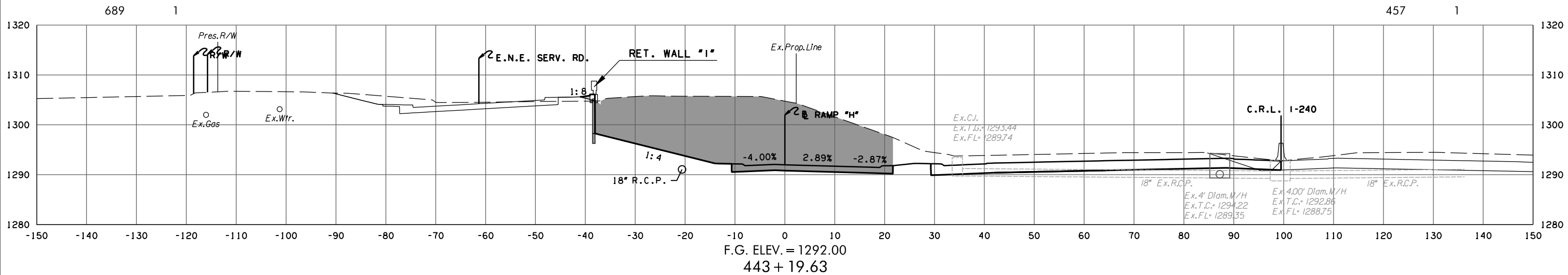

STATE JOB NO. 09032(08)
 OKLAHOMA COUNTY SHEET NO. X222

3/4/2024 3:58:54 PM H:\PROJECTS\2789_CrossRoads_Phase 4\Roadway\Drawings\Sections\0903208-XSEC_Ramp_H.dgn

(CAUTION) THE LOCATION OF ALL UTILITIES AS SHOWN ARE APPROXIMATE. DUE TO RELOCATION'S PLANNED OR PRESENTLY UNDER CONSTRUCTION THERE ARE SOME UTILITIES THAT WILL BE RELOCATED AND NOT SHOWN ON THESE PLANS. THE CONTRACTOR SHALL BE RESPONSIBLE FOR ANY DAMAGE TO ALL UTILITIES.
 DEPTH & LOCATION OF EXISTING UTILITIES SHALL BE FIELD VERIFIED BY THE CONTRACTOR PRIOR TO CONSTRUCTION.

SEE DRAINAGE AREA MAP SHEETS FOR DRAINAGE SYMBOLOLOGY.

R/W & U/E PURCHASED UNDER JP 09032(05)

POB & ASSOCIATES, OKLAHOMA CITY, OK.
90% PLAN SUBMITTAL
 3/4/2024

AREA
 CUT FILL

VOLUME
 CUT FILL

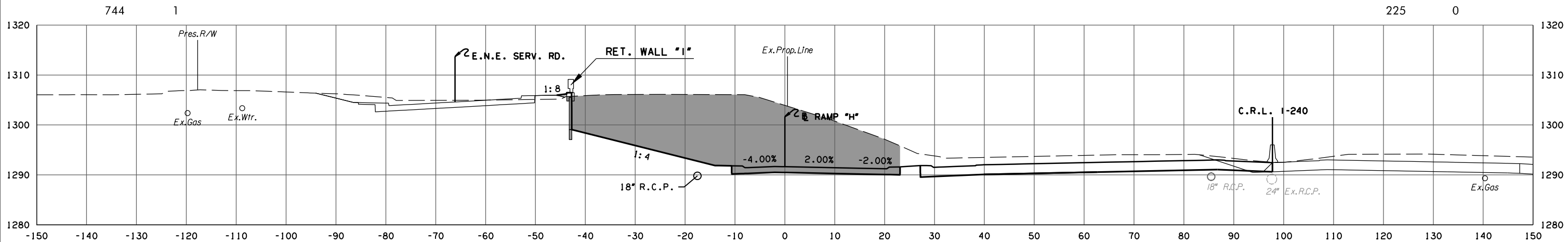

F.G. ELEV. = 1291.64
 443 + 46.26
 CONTINUALLY ROTATING

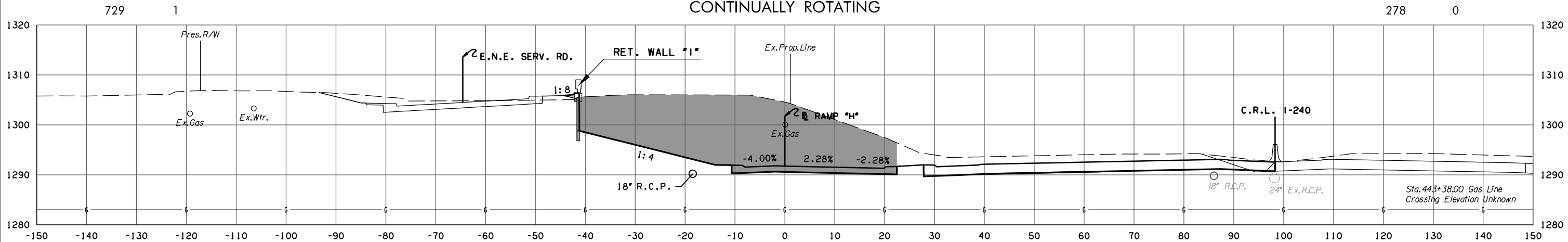

F.G. ELEV. = 1291.75
 443 + 38.00

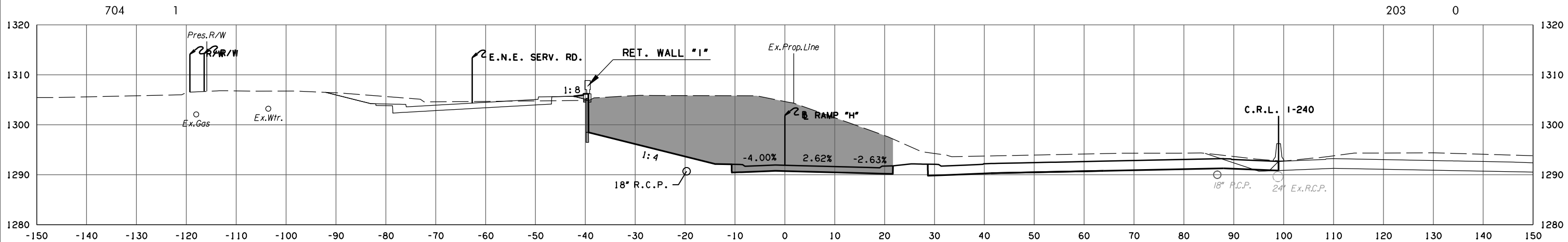

F.G. ELEV. = 1291.89
 443 + 27.51

RAMP H PHASE 4

STATE JOB NO. 09032(08)
 OKLAHOMA COUNTY SHEET NO. X223

3/4/2024 3:58:55 PM H:\PROJECTS\2789_Crossroads_Phase 4\Roadway\Drawings\Sections\0903208-XSEC_Ramp_H.dgn

(CAUTION) THE LOCATION OF ALL UTILITIES AS SHOWN ARE APPROXIMATE. DUE TO RELOCATION'S PLANNED OR PRESENTLY UNDER CONSTRUCTION THERE ARE SOME UTILITIES THAT WILL BE RELOCATED AND NOT SHOWN ON THESE PLANS. THE CONTRACTOR SHALL BE RESPONSIBLE FOR ANY DAMAGE TO ALL UTILITIES.
 DEPTH & LOCATION OF EXISTING UTILITIES SHALL BE FIELD VERIFIED BY THE CONTRACTOR PRIOR TO CONSTRUCTION.

SEE DRAINAGE AREA MAP SHEETS FOR DRAINAGE SYMBOLOLOGY.

R/W & U/E PURCHASED UNDER JP 09032(05)

POB & ASSOCIATES, OKLAHOMA CITY, OK.
90% PLAN SUBMITTAL
 3/4/2024

AREA
 CUT FILL

VOLUME
 CUT FILL

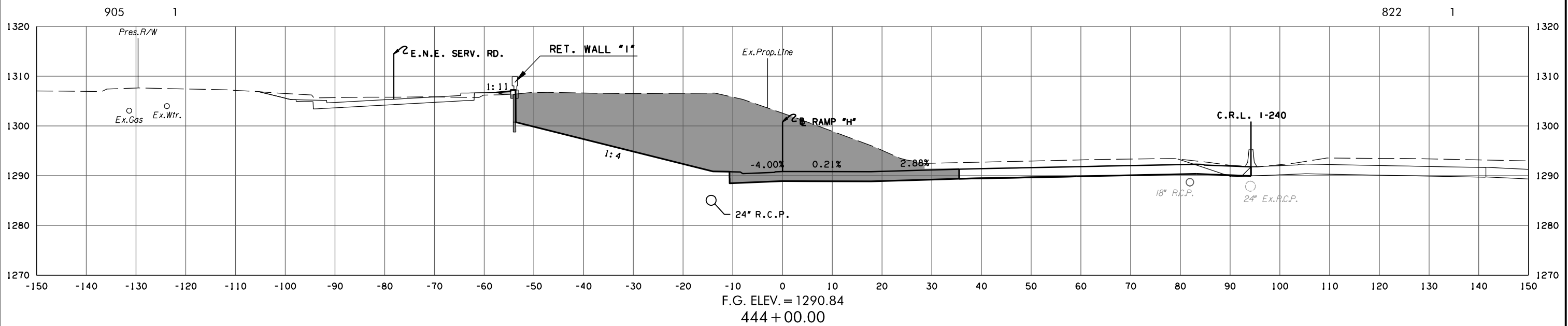

F.G. ELEV. = 1290.84
 444 + 00.00

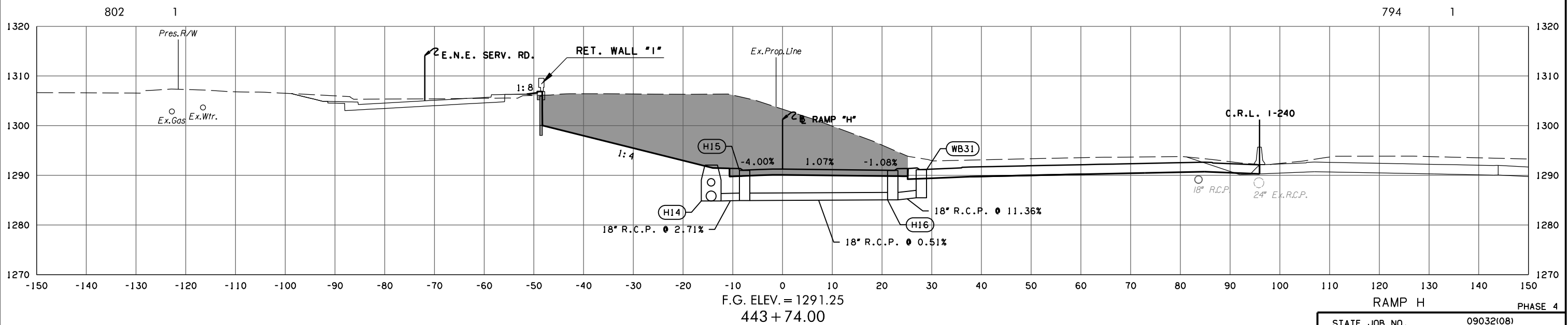

F.G. ELEV. = 1291.25
 443 + 74.00

RAMP H PHASE 4

STATE JOB NO. 09032(08)
 OKLAHOMA COUNTY SHEET NO. X224

3/4/2024 3:58:57 PM
 H:\PROJECTS\2789_CrossRoads_Phase 4\Roadway\Drawings\Sections\0903208-XSEC_Ramp_H.dgn

(CAUTION) THE LOCATION OF ALL UTILITIES AS SHOWN ARE APPROXIMATE. DUE TO RELOCATION'S PLANNED OR PRESENTLY UNDER CONSTRUCTION THERE ARE SOME UTILITIES THAT WILL BE RELOCATED AND NOT SHOWN ON THESE PLANS. THE CONTRACTOR SHALL BE RESPONSIBLE FOR ANY DAMAGE TO ALL UTILITIES.
 DEPTH & LOCATION OF EXISTING UTILITIES SHALL BE FIELD VERIFIED BY THE CONTRACTOR PRIOR TO CONSTRUCTION.

SEE DRAINAGE AREA MAP SHEETS FOR DRAINAGE SYMBOLOLOGY.

R/W & U/E PURCHASED UNDER JP 09032(05)

POB & ASSOCIATES, OKLAHOMA CITY, OK.
90% PLAN SUBMITTAL
 3/4/2024

AREA
 CUT FILL

VOLUME
 CUT FILL

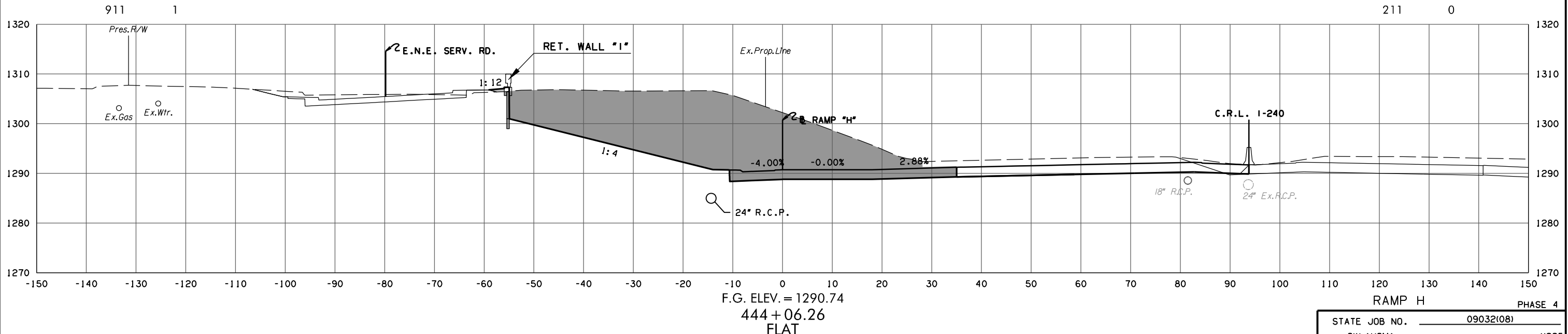
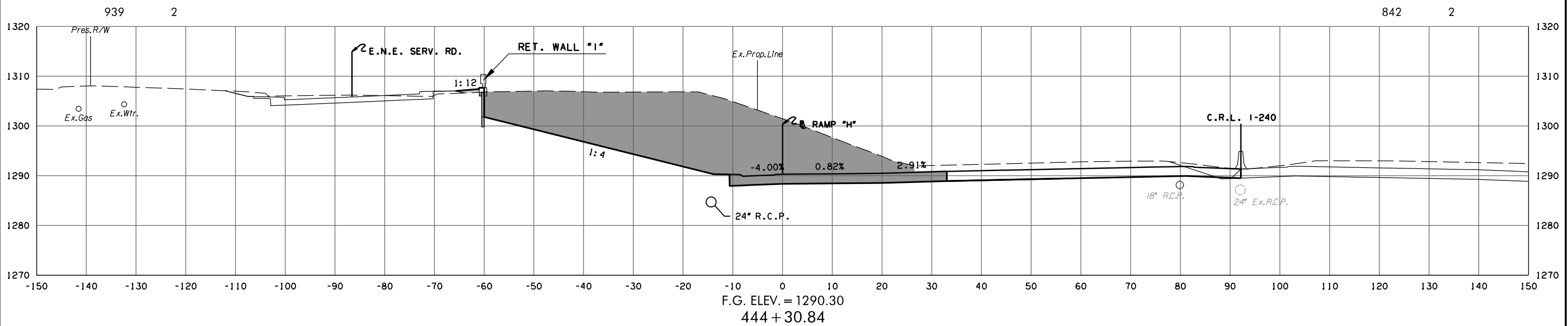

3/4/2024 3:58:58 PM H:\PROJECTS\2789_CrossRoads_Phase 4\Roadway\Drawings\Sections\0903208-XSEC_Ramp_H.dgn

STATE JOB NO. 09032(08)
 OKLAHOMA COUNTY SHEET NO. X225

(CAUTION) THE LOCATION OF ALL UTILITIES AS SHOWN ARE APPROXIMATE. DUE TO RELOCATION'S PLANNED OR PRESENTLY UNDER CONSTRUCTION THERE ARE SOME UTILITIES THAT WILL BE RELOCATED AND NOT SHOWN ON THESE PLANS. THE CONTRACTOR SHALL BE RESPONSIBLE FOR ANY DAMAGE TO ALL UTILITIES.
 DEPTH & LOCATION OF EXISTING UTILITIES SHALL BE FIELD VERIFIED BY THE CONTRACTOR PRIOR TO CONSTRUCTION.

SEE DRAINAGE AREA MAP SHEETS FOR DRAINAGE SYMBOLOLOGY.

R/W & U/E PURCHASED UNDER JP 09032(05)

POB & ASSOCIATES, OKLAHOMA CITY, OK.
90% PLAN SUBMITTAL
 3/4/2024

AREA
 CUT FILL

VOLUME
 CUT FILL

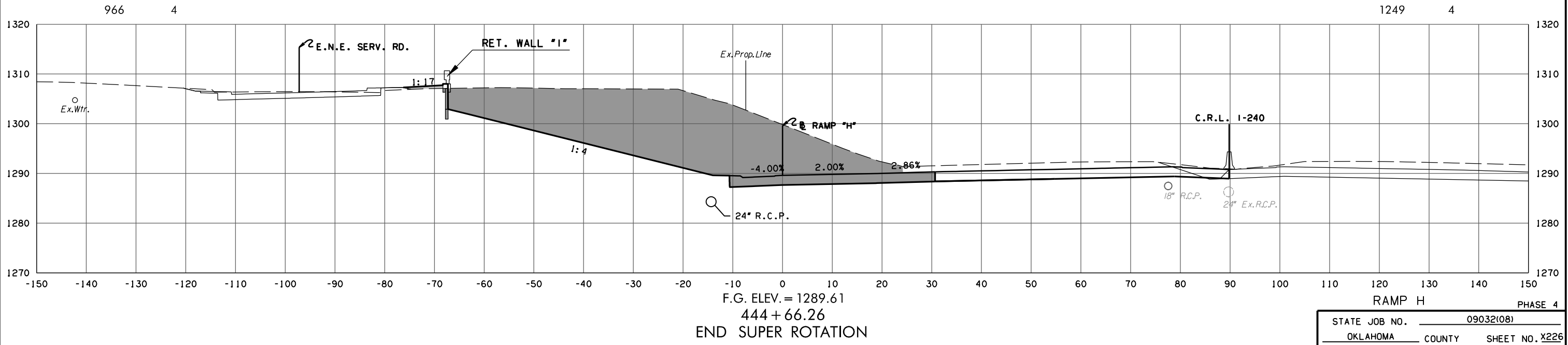
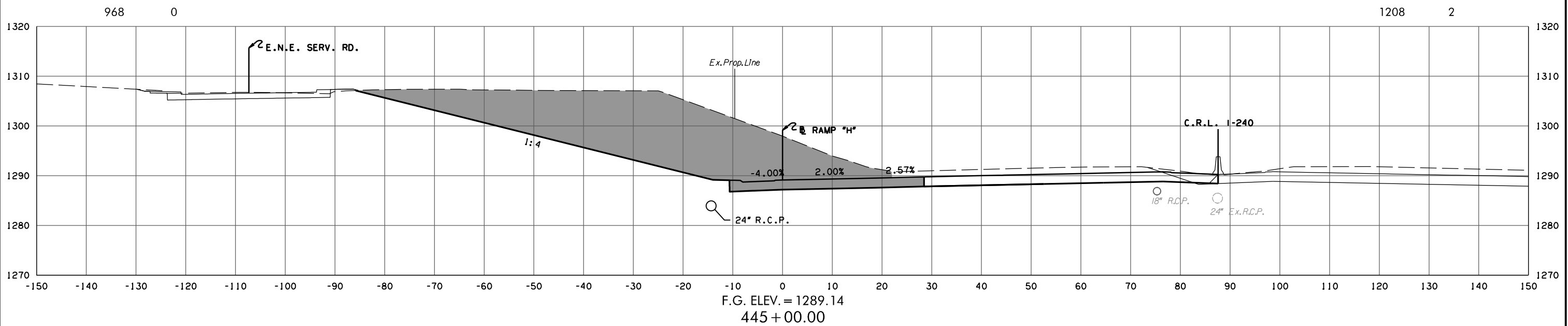

END SUPER ROTATION

STATE JOB NO. 09032(08)
 OKLAHOMA COUNTY SHEET NO. X226

3/4/2024 3:58:59 PM H:\PROJECTS\2789_CrossRoads_Phase 4\Roadway\Drawings\Sections\0903208-XSEC_Ramp_H.dgn

(CAUTION) THE LOCATION OF ALL UTILITIES AS SHOWN ARE APPROXIMATE. DUE TO RELOCATION'S PLANNED OR PRESENTLY UNDER CONSTRUCTION THERE ARE SOME UTILITIES THAT WILL BE RELOCATED AND NOT SHOWN ON THESE PLANS. THE CONTRACTOR SHALL BE RESPONSIBLE FOR ANY DAMAGE TO ALL UTILITIES.
 DEPTH & LOCATION OF EXISTING UTILITIES SHALL BE FIELD VERIFIED BY THE CONTRACTOR PRIOR TO CONSTRUCTION.

SEE DRAINAGE AREA MAP SHEETS FOR DRAINAGE SYMBOLOLOGY.

R/W & U/E PURCHASED UNDER JP 09032(05)

POB & ASSOCIATES, OKLAHOMA CITY, OK.
90% PLAN SUBMITTAL
 3/4/2024

AREA
 CUT FILL

VOLUME
 CUT FILL

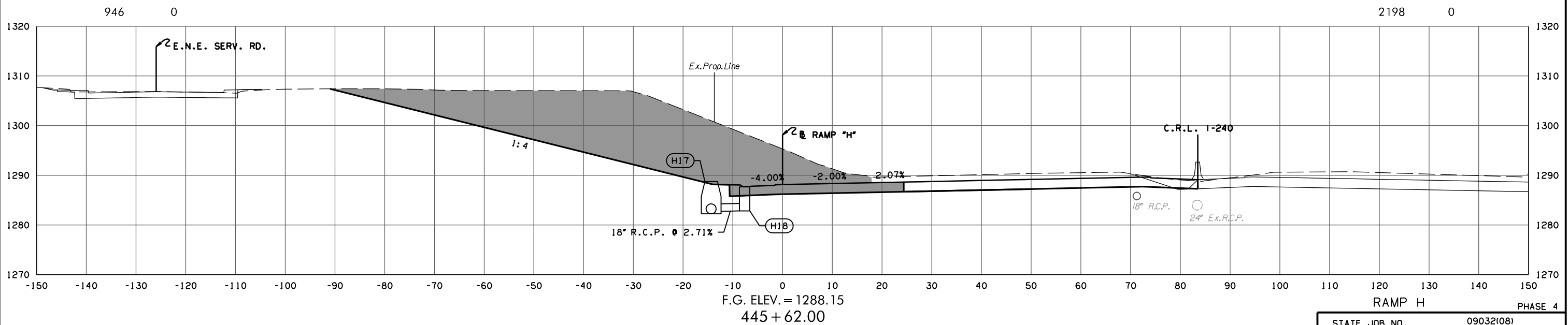
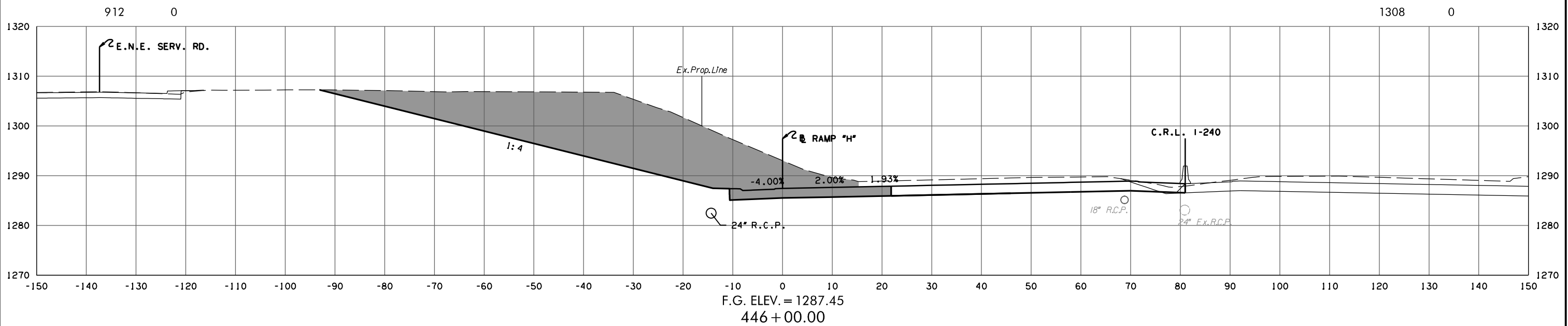

3/4/2024 3:59:00 PM H:\PROJECTS\2789_CrossRoads_Phase 4\Roadway\Drawings\Sections\0903208-XSEC_Ramp_H.dgn

STATE JOB NO. 09032(08)
 OKLAHOMA COUNTY SHEET NO. X227

(CAUTION) THE LOCATION OF ALL UTILITIES AS SHOWN ARE APPROXIMATE. DUE TO RELOCATION'S PLANNED OR PRESENTLY UNDER CONSTRUCTION THERE ARE SOME UTILITIES THAT WILL BE RELOCATED AND NOT SHOWN ON THESE PLANS. THE CONTRACTOR SHALL BE RESPONSIBLE FOR ANY DAMAGE TO ALL UTILITIES.
 DEPTH & LOCATION OF EXISTING UTILITIES SHALL BE FIELD VERIFIED BY THE CONTRACTOR PRIOR TO CONSTRUCTION.

SEE DRAINAGE AREA MAP SHEETS FOR DRAINAGE SYMBOLOLOGY.

R/W & U/E PURCHASED UNDER JP 09032(05)

POB & ASSOCIATES, OKLAHOMA CITY, OK.
90% PLAN SUBMITTAL
 3/4/2024

AREA
 CUT FILL

VOLUME
 CUT FILL

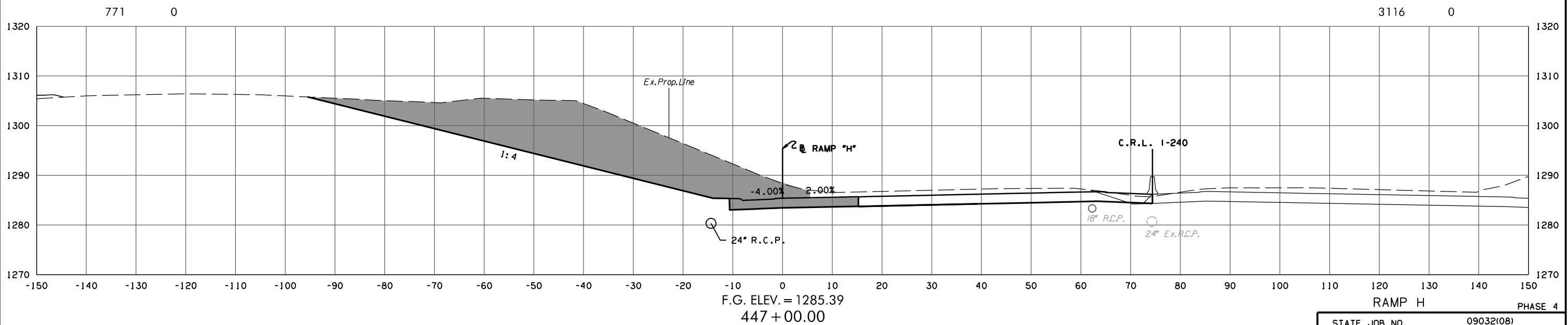
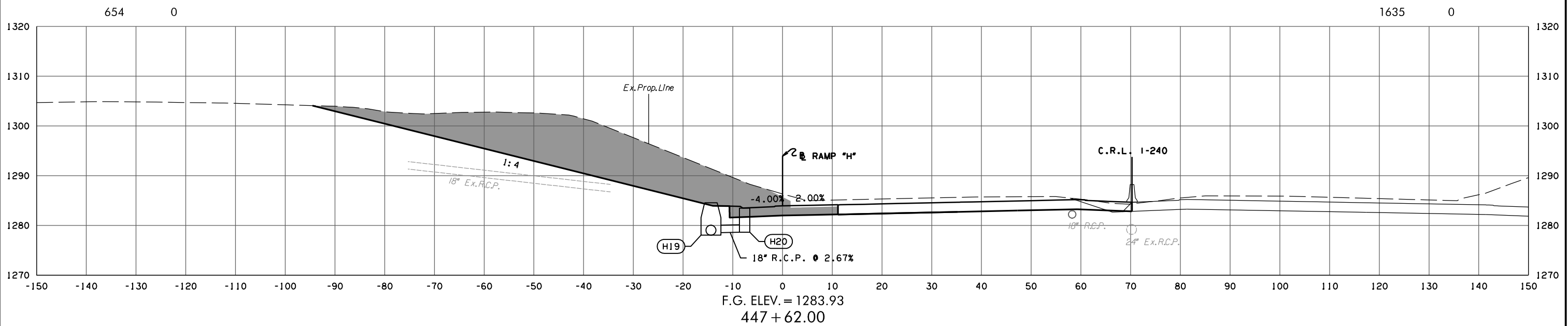

3/4/2024 3:59:01 PM H:\PROJECTS\2789_CrossRoads_Phase 4\Roadway\Drawings\Sections\0903208-XSEC_Ramp_H.dgn

STATE JOB NO. 09032(08)
 OKLAHOMA COUNTY SHEET NO. X228

(CAUTION) THE LOCATION OF ALL UTILITIES AS SHOWN ARE APPROXIMATE. DUE TO RELOCATION'S PLANNED OR PRESENTLY UNDER CONSTRUCTION THERE ARE SOME UTILITIES THAT WILL BE RELOCATED AND NOT SHOWN ON THESE PLANS. THE CONTRACTOR SHALL BE RESPONSIBLE FOR ANY DAMAGE TO ALL UTILITIES.
 DEPTH & LOCATION OF EXISTING UTILITIES SHALL BE FIELD VERIFIED BY THE CONTRACTOR PRIOR TO CONSTRUCTION.

SEE DRAINAGE AREA MAP SHEETS FOR DRAINAGE SYMBOLOLOGY.

R/W & U/E PURCHASED UNDER JP 09032(05)

POB & ASSOCIATES, OKLAHOMA CITY, OK.
90% PLAN SUBMITTAL
 3/4/2024

AREA
 CUT FILL

VOLUME
 CUT FILL

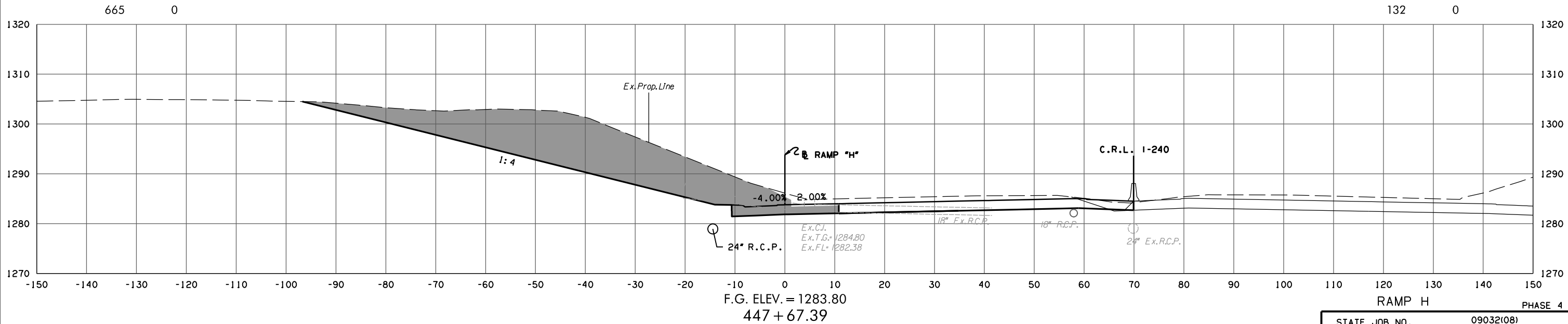
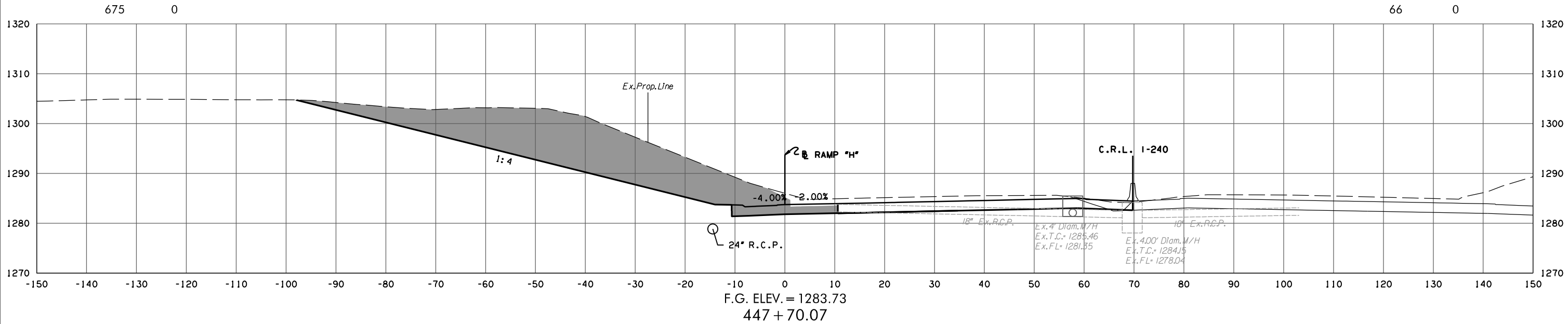

3/4/2024 3:59:02 PM H:\PROJECTS\2789_CrossRoads_Phase 4\Roadway\Drawings\Sections\0903208-XSEC_Ramp_H.dgn

STATE JOB NO. 09032(08)
 OKLAHOMA COUNTY SHEET NO. X229

(CAUTION) THE LOCATION OF ALL UTILITIES AS SHOWN ARE APPROXIMATE. DUE TO RELOCATION'S PLANNED OR PRESENTLY UNDER CONSTRUCTION THERE ARE SOME UTILITIES THAT WILL BE RELOCATED AND NOT SHOWN ON THESE PLANS. THE CONTRACTOR SHALL BE RESPONSIBLE FOR ANY DAMAGE TO ALL UTILITIES.
 DEPTH & LOCATION OF EXISTING UTILITIES SHALL BE FIELD VERIFIED BY THE CONTRACTOR PRIOR TO CONSTRUCTION.

SEE DRAINAGE AREA MAP SHEETS FOR DRAINAGE SYMBOLOLOGY.

R/W & U/E PURCHASED UNDER JP 09032(05)

POB & ASSOCIATES, OKLAHOMA CITY, OK.

90% PLAN SUBMITTAL

3/4/2024

AREA
 CUT FILL

VOLUME
 CUT FILL

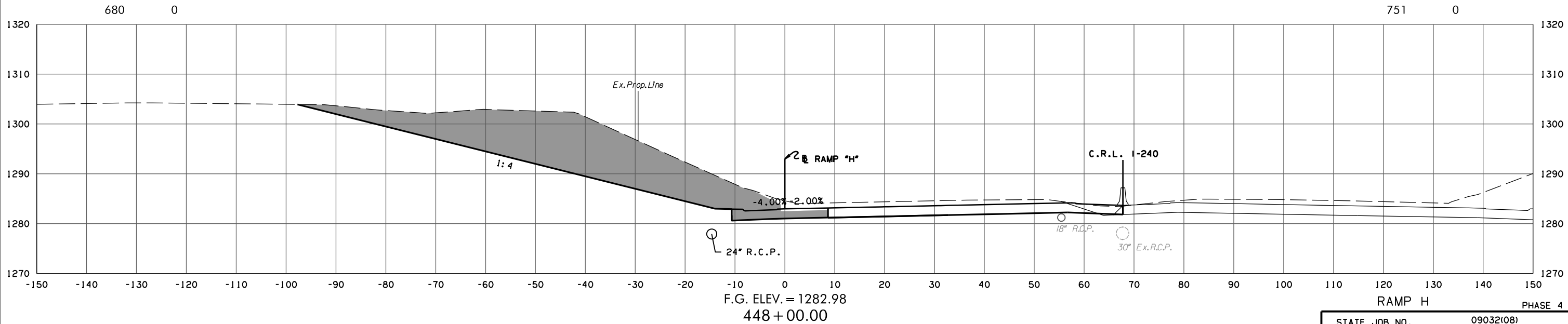
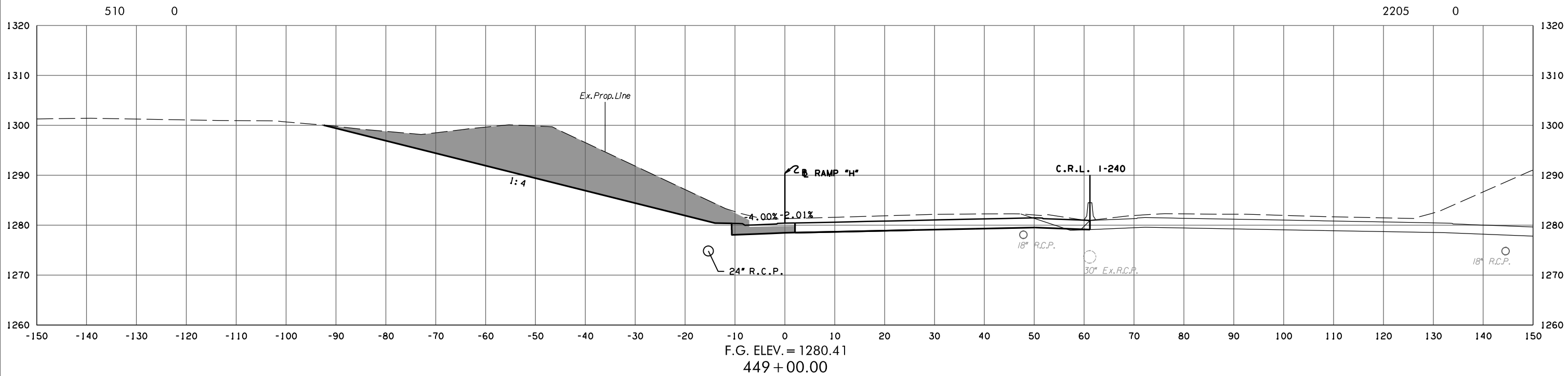

3/4/2024 3:59:03 PM H:\PROJECTS\2789_CrossRoads_Phase 4\Roadway\Drawings\Sections\0903208-XSEC_Ramp_H.dgn

(CAUTION) THE LOCATION OF ALL UTILITIES AS SHOWN ARE APPROXIMATE. DUE TO RELOCATION'S PLANNED OR PRESENTLY UNDER CONSTRUCTION THERE ARE SOME UTILITIES THAT WILL BE RELOCATED AND NOT SHOWN ON THESE PLANS. THE CONTRACTOR SHALL BE RESPONSIBLE FOR ANY DAMAGE TO ALL UTILITIES.
 DEPTH & LOCATION OF EXISTING UTILITIES SHALL BE FIELD VERIFIED BY THE CONTRACTOR PRIOR TO CONSTRUCTION.

SEE DRAINAGE AREA MAP SHEETS FOR DRAINAGE SYMBOLOLOGY.

R/W & U/E PURCHASED UNDER JP 09032(05)

POB & ASSOCIATES, OKLAHOMA CITY, OK.
90% PLAN SUBMITTAL
 3/4/2024

AREA
 CUT FILL

VOLUME
 CUT FILL

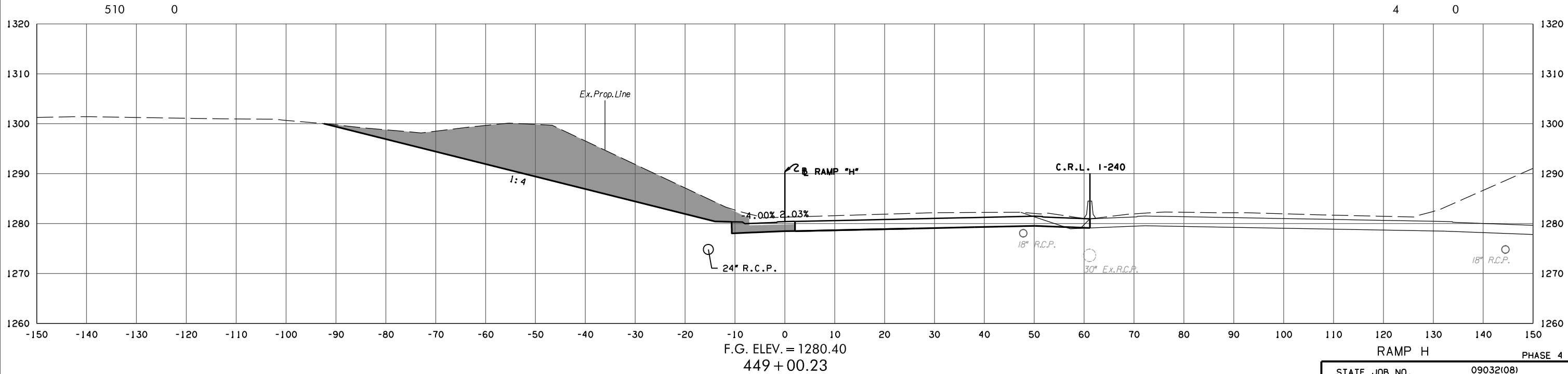
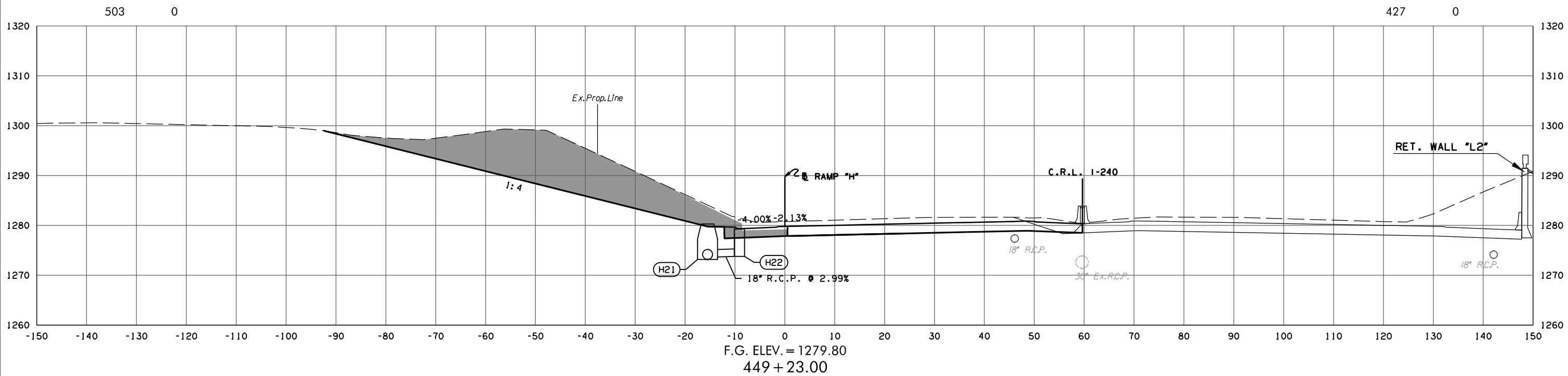

3/4/2024 3:59:04 PM H:\PROJECTS\2789_CrossRoads_Phase 4\Roadway\Drawings\Sections\0903208-XSEC_Ramp_H.dgn

STATE JOB NO. 09032(08)
 OKLAHOMA COUNTY SHEET NO. X231

(CAUTION) THE LOCATION OF ALL UTILITIES AS SHOWN ARE APPROXIMATE. DUE TO RELOCATION'S PLANNED OR PRESENTLY UNDER CONSTRUCTION THERE ARE SOME UTILITIES THAT WILL BE RELOCATED AND NOT SHOWN ON THESE PLANS. THE CONTRACTOR SHALL BE RESPONSIBLE FOR ANY DAMAGE TO ALL UTILITIES.
 DEPTH & LOCATION OF EXISTING UTILITIES SHALL BE FIELD VERIFIED BY THE CONTRACTOR PRIOR TO CONSTRUCTION.

SEE DRAINAGE AREA MAP SHEETS FOR DRAINAGE SYMBOLOLOGY.

R/W & U/E PURCHASED UNDER JP 09032(05)

POB & ASSOCIATES, OKLAHOMA CITY, OK.
90% PLAN SUBMITTAL
 3/4/2024

AREA
 CUT FILL

VOLUME
 CUT FILL

3/4/2024 3:59:05 PM H:\PROJECTS\2789_CrossRoads_Phase 4\Roadway\Drawings\Sections\0903208-XSEC_Ramp_H.dgn

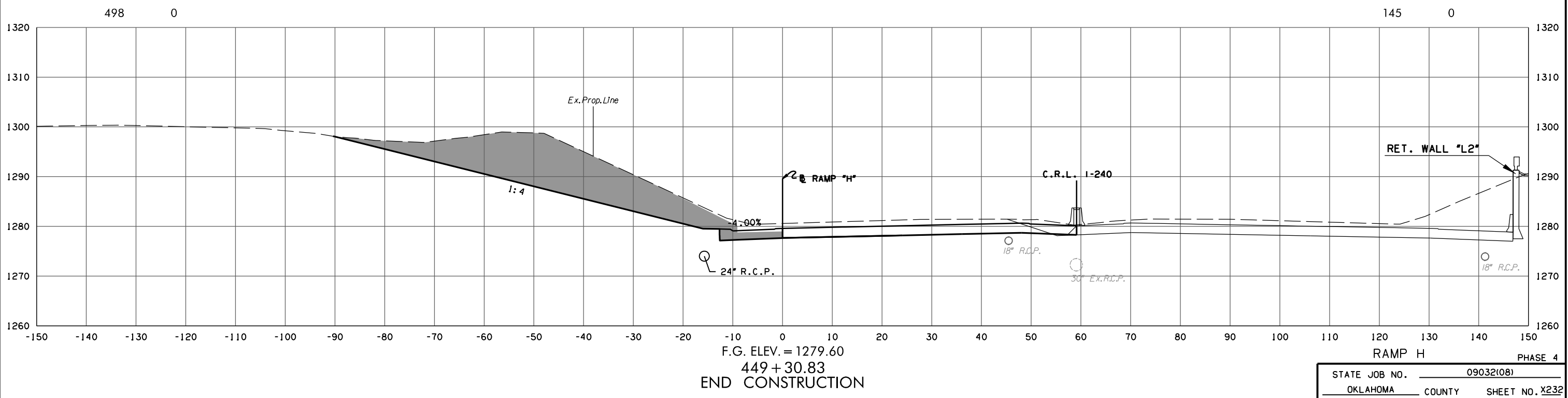

STATE JOB NO. 09032(08)
 OKLAHOMA COUNTY SHEET NO. X232

(CAUTION) THE LOCATION OF ALL UTILITIES AS SHOWN ARE APPROXIMATE. DUE TO RELOCATION'S PLANNED OR PRESENTLY UNDER CONSTRUCTION THERE ARE SOME UTILITIES THAT WILL BE RELOCATED AND NOT SHOWN ON THESE PLANS. THE CONTRACTOR SHALL BE RESPONSIBLE FOR ANY DAMAGE TO ALL UTILITIES.

SEE DRAINAGE AREA MAP SHEETS FOR DRAINAGE SYMBOLOLOGY.

R/W & U/E PURCHASED UNDER JP 09032(05)

POB & ASSOCIATES, OKLAHOMA CITY, OK.

**90% PLAN
SUBMITTAL**

3/4/2024

AREA
CUT FILL

VOLUME
CUT FILL

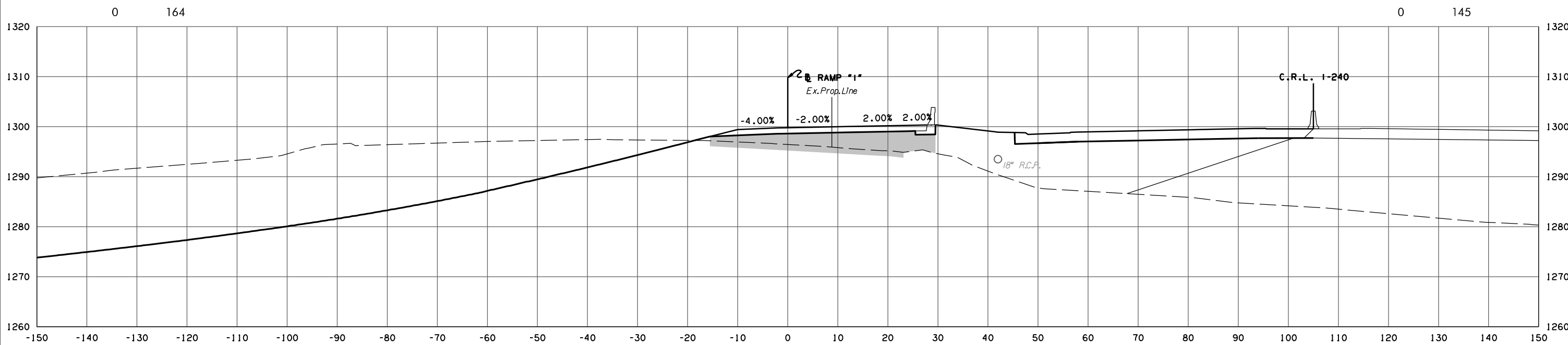

F.G. ELEV. = 1299.79
425 + 69.07
END LANE ROTATION

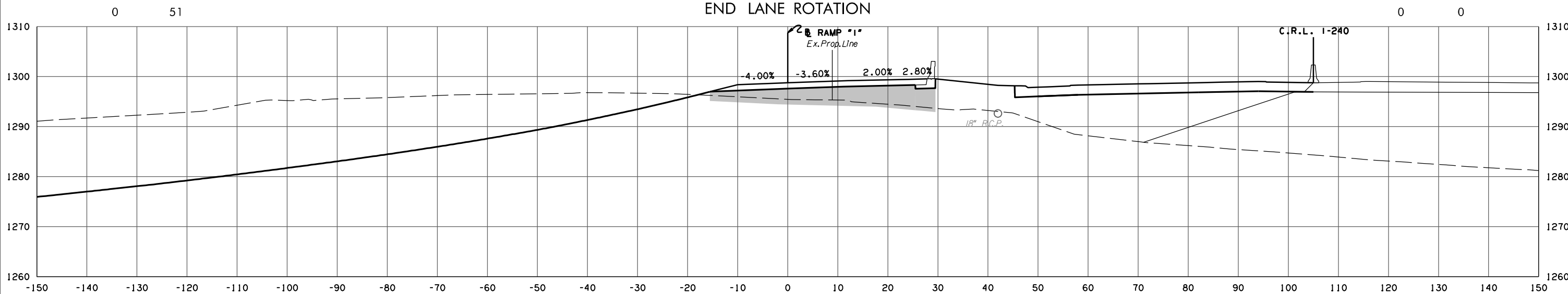

F.G. ELEV. = 1298.76
425 + 32.69
BEGIN CONSTRUCTION BEGIN LANE ROTATION

RAMP I PHASE 4

STATE JOB NO. 09032(08)
OKLAHOMA COUNTY SHEET NO. X233

3/4/2024 3:59:06 PM H:\PROJECTS\2789_CrossRoads_Phase 4\Roadway\Drawings\Sections\0903208-XSEC_Ramp_I.dgn

(CAUTION) THE LOCATION OF ALL UTILITIES AS SHOWN ARE APPROXIMATE. DUE TO RELOCATION'S PLANNED OR PRESENTLY UNDER CONSTRUCTION THERE ARE SOME UTILITIES THAT WILL BE RELOCATED AND NOT SHOWN ON THESE PLANS. THE CONTRACTOR SHALL BE RESPONSIBLE FOR ANY DAMAGE TO ALL UTILITIES.

DEPTH & LOCATION OF EXISTING UTILITIES SHALL BE FIELD VERIFIED BY THE CONTRACTOR PRIOR TO CONSTRUCTION.

SEE DRAINAGE AREA MAP SHEETS FOR DRAINAGE SYMBOLOLOGY.

R/W & U/E PURCHASED UNDER JP 09032(05)

POB & ASSOCIATES, OKLAHOMA CITY, OK.

**90% PLAN
SUBMITTAL**

3/4/2024

AREA
CUT FILL

VOLUME
CUT FILL

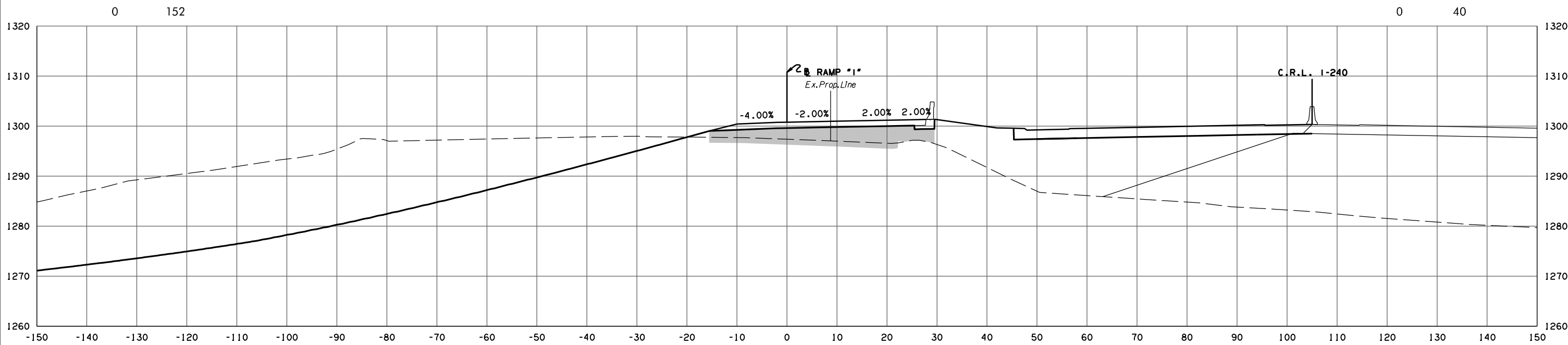

F.G. ELEV. = 1300.79

426 + 07.00

BEGIN SHOULDER ROTATION

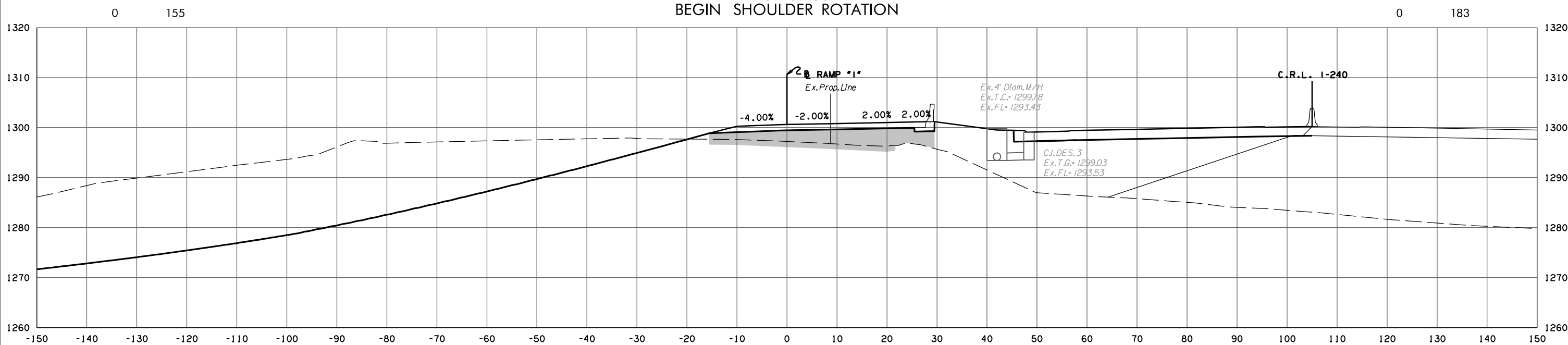

F.G. ELEV. = 1300.61

426 + 00.00

RAMP I PHASE 4

STATE JOB NO. 09032(08)
OKLAHOMA COUNTY SHEET NO. X234

3/4/2024 3:59:07 PM H:\PROJECTS\2789_CrossRoads_Phase 4\Roadway\Drawings\Sections\0903208-XSEC_Ramp_1.dgn

(CAUTION) THE LOCATION OF ALL UTILITIES AS SHOWN ARE APPROXIMATE. DUE TO RELOCATION'S PLANNED OR PRESENTLY UNDER CONSTRUCTION THERE ARE SOME UTILITIES THAT WILL BE RELOCATED AND NOT SHOWN ON THESE PLANS. THE CONTRACTOR SHALL BE RESPONSIBLE FOR ANY DAMAGE TO ALL UTILITIES.

DEPTH & LOCATION OF EXISTING UTILITIES SHALL BE FIELD VERIFIED BY THE CONTRACTOR PRIOR TO CONSTRUCTION.

SEE DRAINAGE AREA MAP SHEETS FOR DRAINAGE SYMBOLOLOGY.

R/W & U/E PURCHASED UNDER JP 09032(05)

POB & ASSOCIATES, OKLAHOMA CITY, OK.

**90% PLAN
SUBMITTAL**

3/4/2024

AREA
CUT FILL

VOLUME
CUT FILL

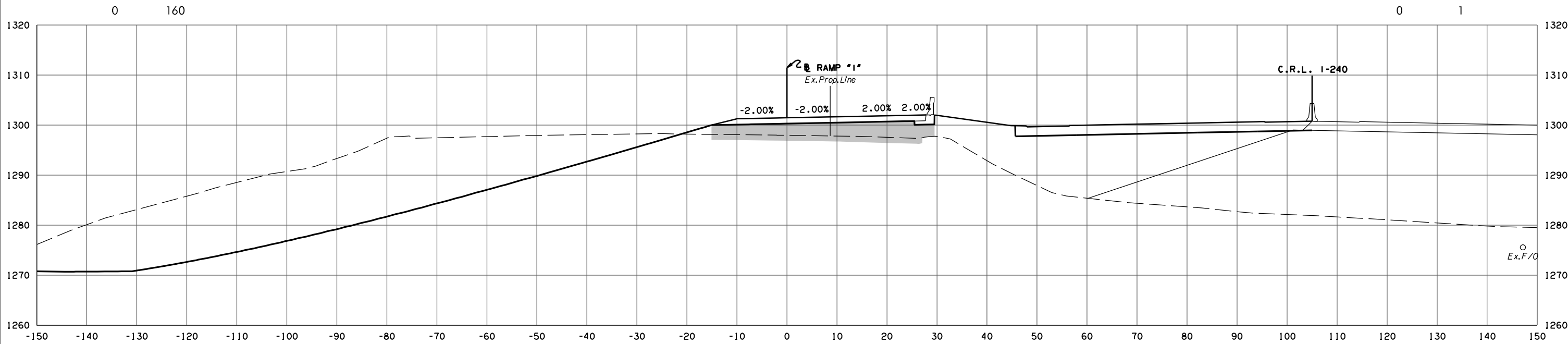

F.G. ELEV. = 1301.48
426 + 37.18
BEGIN APPROACH SLAB

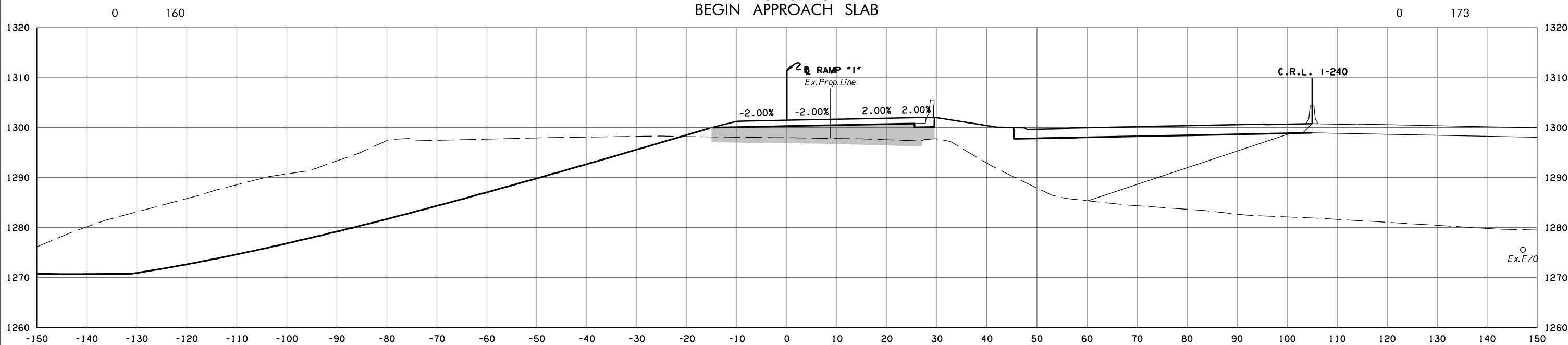

F.G. ELEV. = 1301.47
426 + 37.00
END SHOULDER ROTATION

STATE JOB NO. 09032(08)
OKLAHOMA COUNTY SHEET NO. X235

3/4/2024 3:59:07 PM
H:\PROJECTS\2789_CrossRoads_Phase 4\Roadway\Drawings\Sections\0903208-XSEC_Ramp_1.dgn

(CAUTION) THE LOCATION OF ALL UTILITIES AS SHOWN ARE APPROXIMATE. DUE TO RELOCATION'S PLANNED OR PRESENTLY UNDER CONSTRUCTION THERE ARE SOME UTILITIES THAT WILL BE RELOCATED AND NOT SHOWN ON THESE PLANS. THE CONTRACTOR SHALL BE RESPONSIBLE FOR ANY DAMAGE TO ALL UTILITIES.

DEPTH & LOCATION OF EXISTING UTILITIES SHALL BE FIELD VERIFIED BY THE CONTRACTOR PRIOR TO CONSTRUCTION.

SEE DRAINAGE AREA MAP SHEETS FOR DRAINAGE SYMBOLOLOGY.

R/W & U/E PURCHASED UNDER JP 09032(05)

POB & ASSOCIATES, OKLAHOMA CITY, OK.

**90% PLAN
SUBMITTAL**

3/4/2024

AREA
CUT FILL

VOLUME
CUT FILL

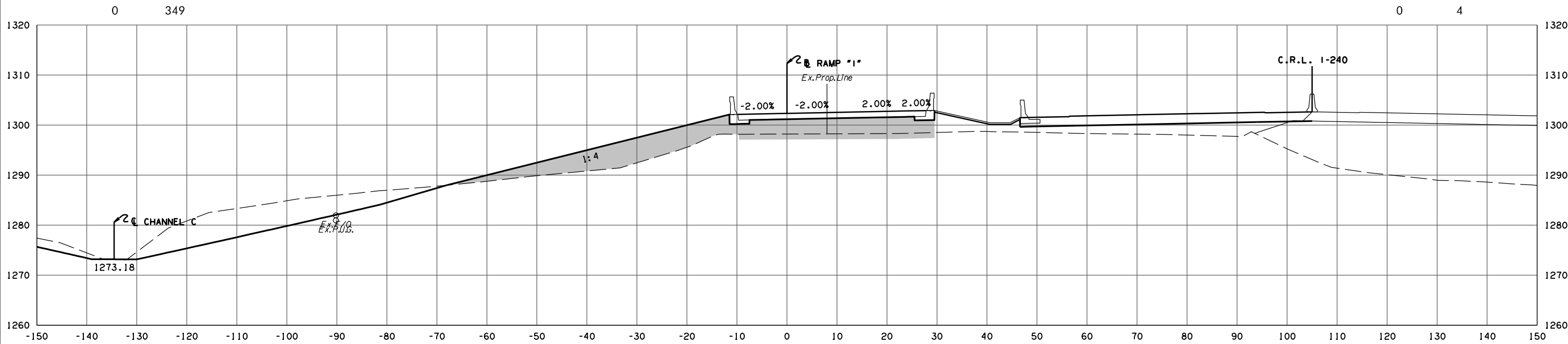

F.G. ELEV. = 1302.35
430+06.00
BEGIN SHOULDER ROTATION

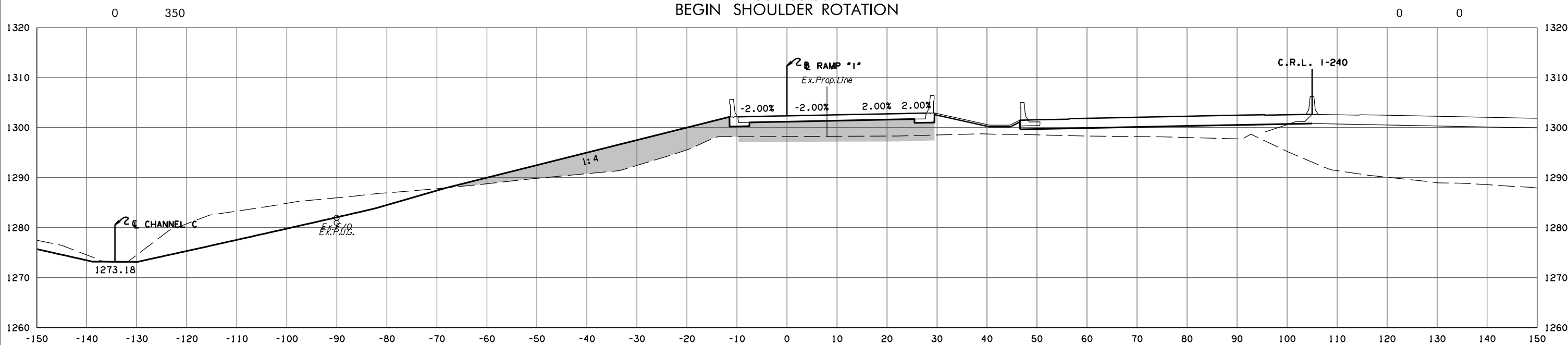

F.G. ELEV. = 1302.35
430+05.68
END APPROACH SLAB

RAMP I PHASE 4

STATE JOB NO. 09032(08)
OKLAHOMA COUNTY SHEET NO. X236

3/4/2024 3:59:08 PM H:\PROJECTS\2789_CrossRoads_Phase 4\Roadway\Drawings\Sections\0903208-XSEC_Ramp_I.dgn

(CAUTION) THE LOCATION OF ALL UTILITIES AS SHOWN ARE APPROXIMATE. DUE TO RELOCATION'S PLANNED OR PRESENTLY UNDER CONSTRUCTION THERE ARE SOME UTILITIES THAT WILL BE RELOCATED AND NOT SHOWN ON THESE PLANS. THE CONTRACTOR SHALL BE RESPONSIBLE FOR ANY DAMAGE TO ALL UTILITIES.

DEPTH & LOCATION OF EXISTING UTILITIES SHALL BE FIELD VERIFIED BY THE CONTRACTOR PRIOR TO CONSTRUCTION.

SEE DRAINAGE AREA MAP SHEETS FOR DRAINAGE SYMBOLOLOGY.

R/W & U/E PURCHASED UNDER JP 09032(05)

POB & ASSOCIATES, OKLAHOMA CITY, OK.

**90% PLAN
SUBMITTAL**

3/4/2024

AREA
CUT FILL

VOLUME
CUT FILL

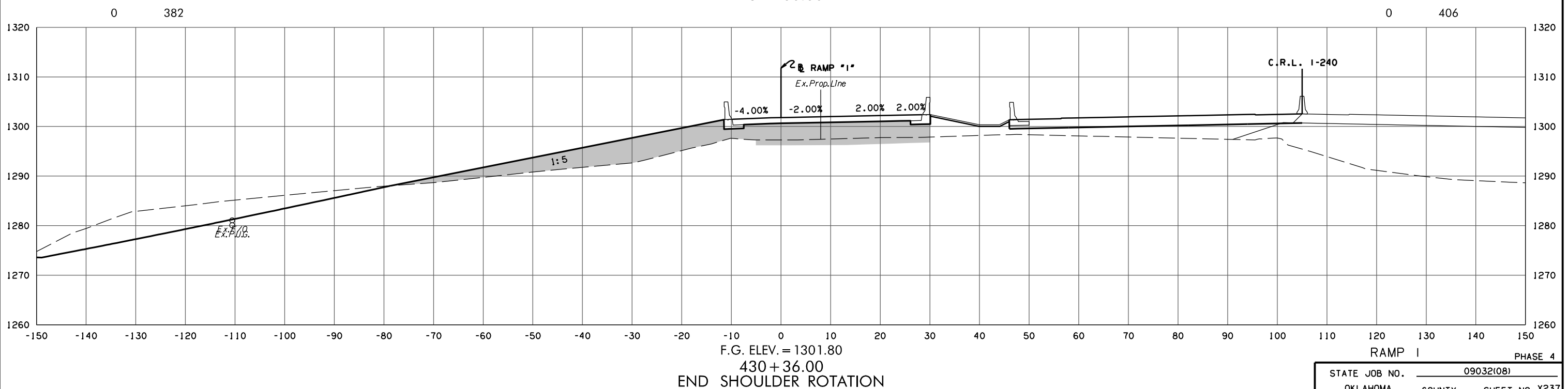
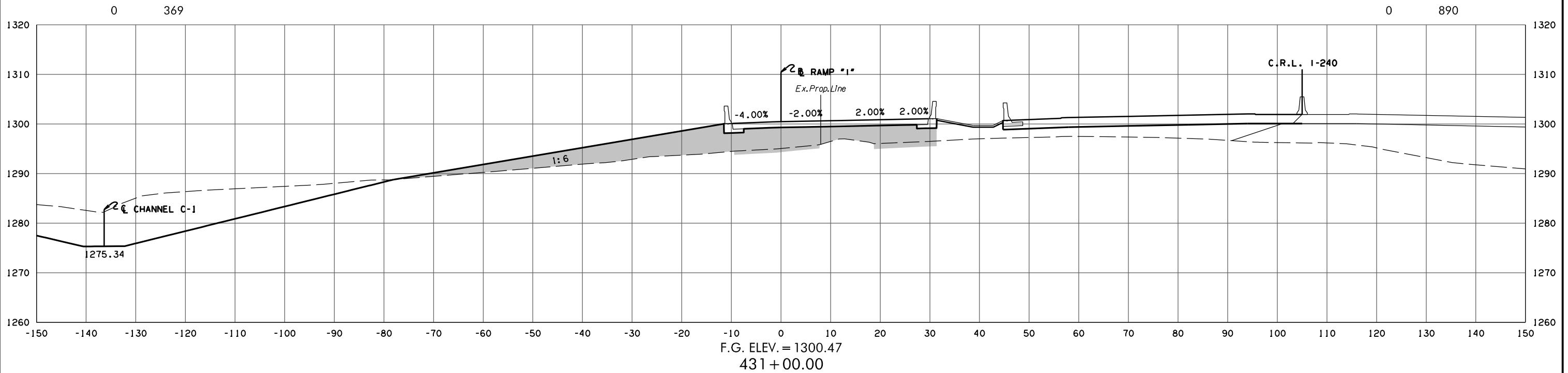

3/4/2024 3:59:08 PM H:\PROJECTS\2789_CrossRoads_Phase 4\Roadway\Drawings\Sections\0903208-XSEC_Ramp_1.dgn

STATE JOB NO. 09032(08)
OKLAHOMA COUNTY SHEET NO. X237

(CAUTION) THE LOCATION OF ALL UTILITIES AS SHOWN ARE APPROXIMATE. DUE TO RELOCATION'S PLANNED OR PRESENTLY UNDER CONSTRUCTION THERE ARE SOME UTILITIES THAT WILL BE RELOCATED AND NOT SHOWN ON THESE PLANS. THE CONTRACTOR SHALL BE RESPONSIBLE FOR ANY DAMAGE TO ALL UTILITIES.

DEPTH & LOCATION OF EXISTING UTILITIES SHALL BE FIELD VERIFIED BY THE CONTRACTOR PRIOR TO CONSTRUCTION.

SEE DRAINAGE AREA MAP SHEETS FOR DRAINAGE SYMBOLOLOGY.

R/W & U/E PURCHASED UNDER JP 09032(05)

POB & ASSOCIATES, OKLAHOMA CITY, OK.

**90% PLAN
SUBMITTAL**

3/4/2024

AREA
CUT FILL

VOLUME
CUT FILL

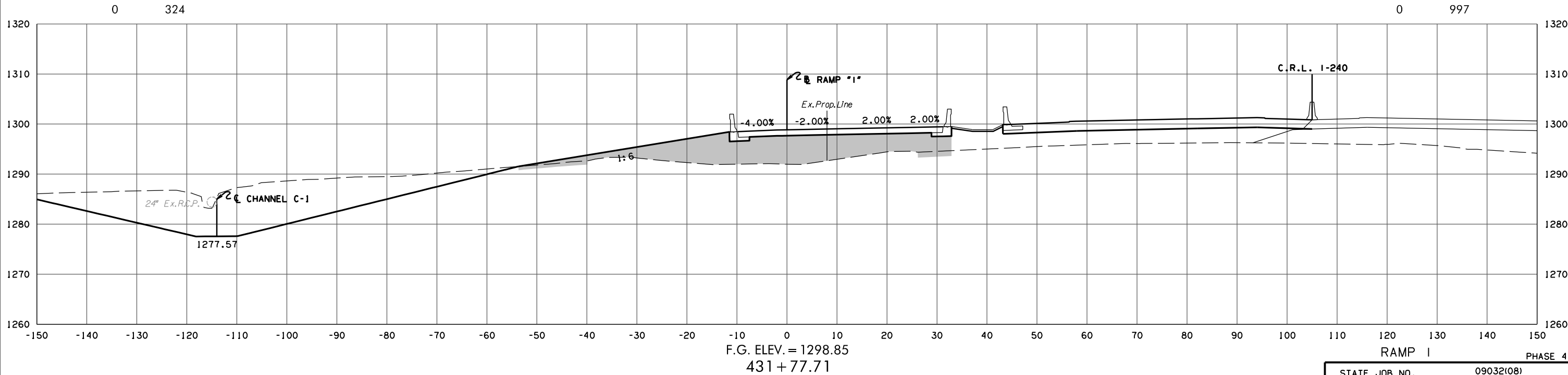
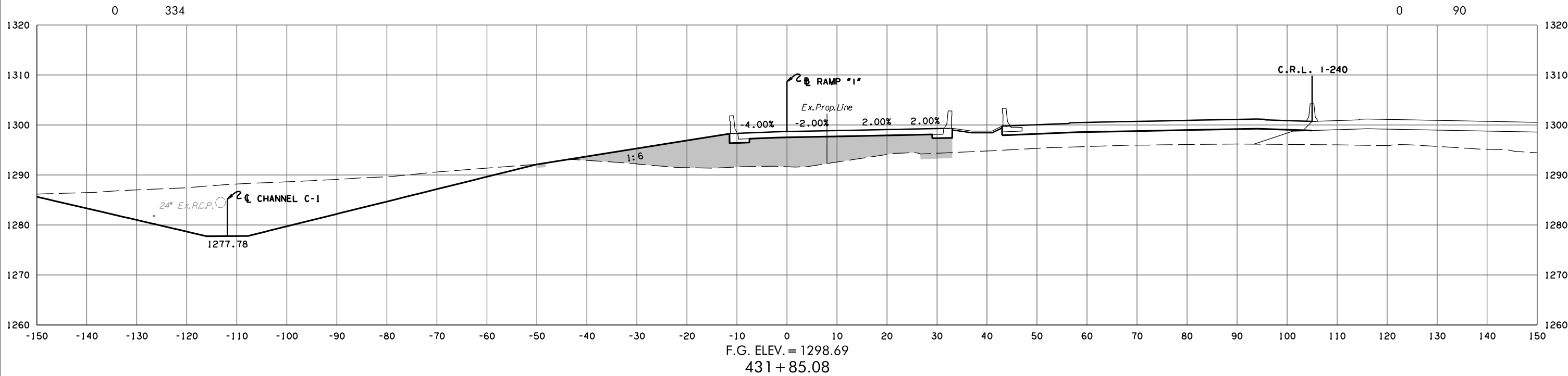

3/4/2024 3:59:09 PM H:\PROJECTS\2789_CrossRoads_Phase 4\Roadway\Drawings\Sections\0903208-XSEC_Ramp_1.dgn

STATE JOB NO. 09032(08)
OKLAHOMA COUNTY SHEET NO. X238

RAMP I PHASE 4

(CAUTION) THE LOCATION OF ALL UTILITIES AS SHOWN ARE APPROXIMATE. DUE TO RELOCATION'S PLANNED OR PRESENTLY UNDER CONSTRUCTION THERE ARE SOME UTILITIES THAT WILL BE RELOCATED AND NOT SHOWN ON THESE PLANS. THE CONTRACTOR SHALL BE RESPONSIBLE FOR ANY DAMAGE TO ALL UTILITIES.

DEPTH & LOCATION OF EXISTING UTILITIES SHALL BE FIELD VERIFIED BY THE CONTRACTOR PRIOR TO CONSTRUCTION.

SEE DRAINAGE AREA MAP SHEETS FOR DRAINAGE SYMBOLOLOGY.

R/W & U/E PURCHASED UNDER JP 09032(05)

POB & ASSOCIATES, OKLAHOMA CITY, OK.

**90% PLAN
SUBMITTAL**

3/4/2024

AREA
CUT FILL

VOLUME
CUT FILL

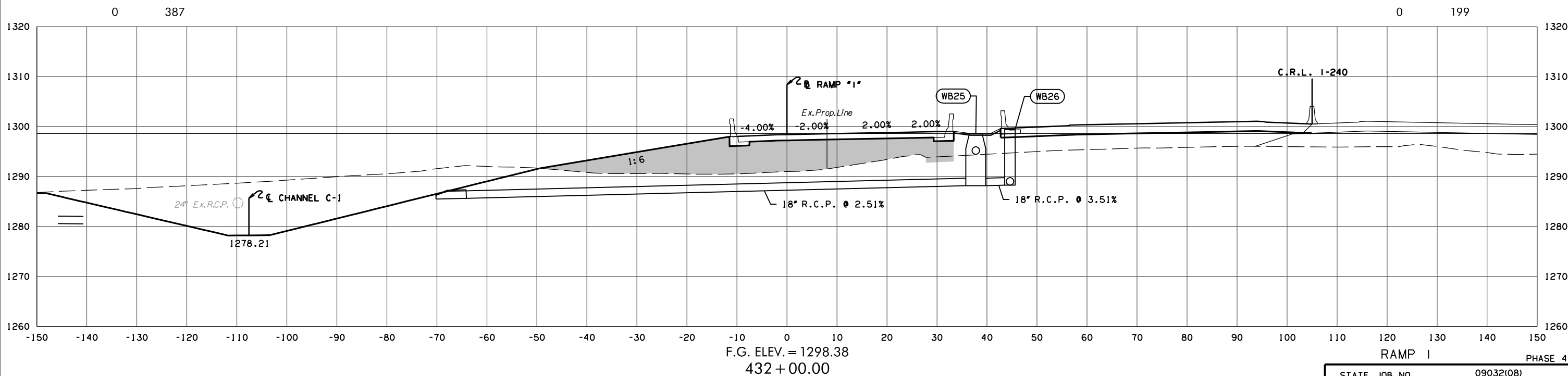
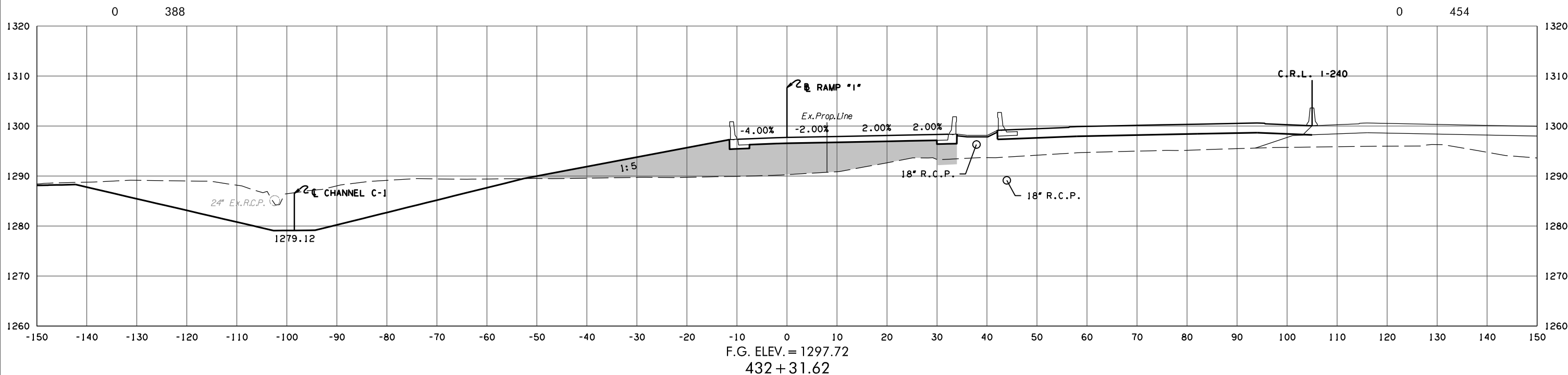

3/4/2024 3:59:10 PM H:\PROJECTS\2789_CrossRoads_Phase 4\Roadway\Drawings\Sections\0903208-XSEC_Ramp_1.dgn

(CAUTION) THE LOCATION OF ALL UTILITIES AS SHOWN ARE APPROXIMATE. DUE TO RELOCATION'S PLANNED OR PRESENTLY UNDER CONSTRUCTION THERE ARE SOME UTILITIES THAT WILL BE RELOCATED AND NOT SHOWN ON THESE PLANS. THE CONTRACTOR SHALL BE RESPONSIBLE FOR ANY DAMAGE TO ALL UTILITIES.

DEPTH & LOCATION OF EXISTING UTILITIES SHALL BE FIELD VERIFIED BY THE CONTRACTOR PRIOR TO CONSTRUCTION.

SEE DRAINAGE AREA MAP SHEETS FOR DRAINAGE SYMBOLOLOGY.

R/W & U/E PURCHASED UNDER JP 09032(05)

POB & ASSOCIATES, OKLAHOMA CITY, OK.

90% PLAN SUBMITTAL

3/4/2024

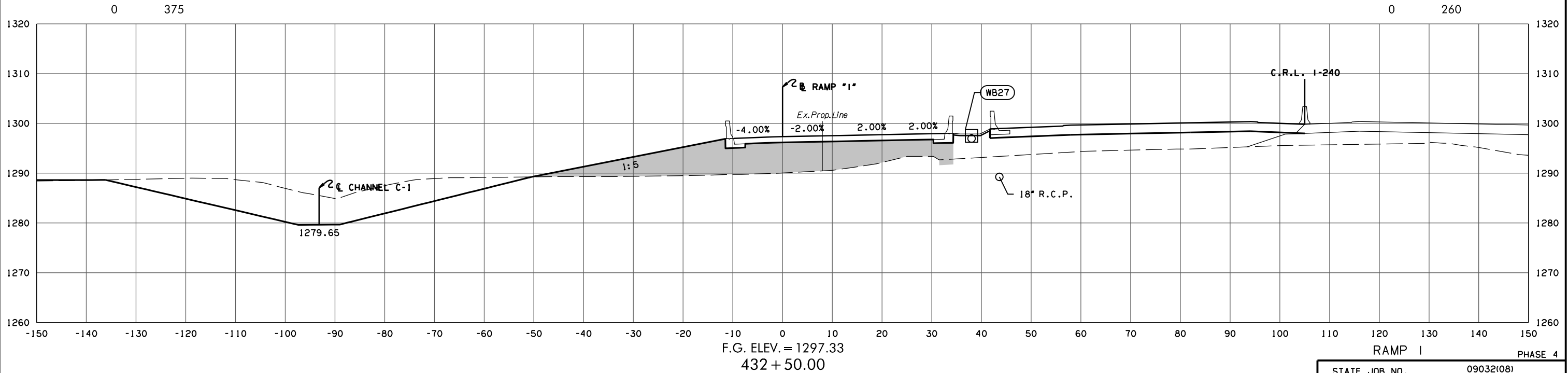
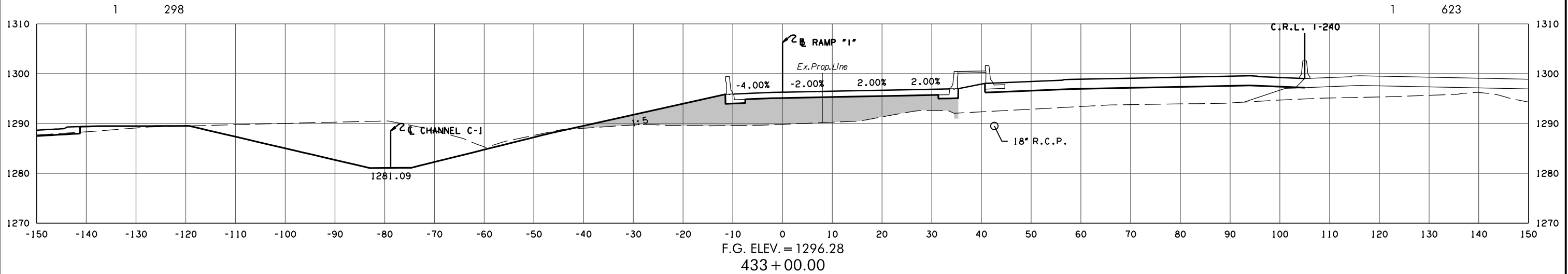
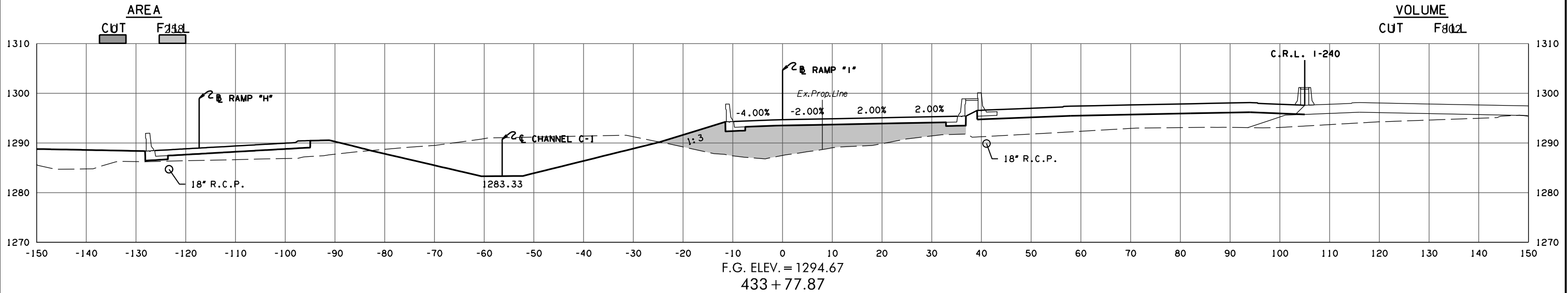

3/4/2024 3:59:10 PM H:\PROJECTS\2789_CrossRoads_Phase 4\Roadway\Drawings\Sections\0903208-XSEC_Ramp_I.dgn

(CAUTION) THE LOCATION OF ALL UTILITIES AS SHOWN ARE APPROXIMATE. DUE TO RELOCATION'S PLANNED OR PRESENTLY UNDER CONSTRUCTION THERE ARE SOME UTILITIES THAT WILL BE RELOCATED AND NOT SHOWN ON THESE PLANS. THE CONTRACTOR SHALL BE RESPONSIBLE FOR ANY DAMAGE TO ALL UTILITIES.
 DEPTH & LOCATION OF EXISTING UTILITIES SHALL BE FIELD VERIFIED BY THE CONTRACTOR PRIOR TO CONSTRUCTION.

SEE DRAINAGE AREA MAP SHEETS FOR DRAINAGE SYMBOLOLOGY.

R/W & U/E PURCHASED UNDER JP 09032(05)

POB & ASSOCIATES, OKLAHOMA CITY, OK.

90% PLAN SUBMITTAL

3/4/2024

AREA
 CUT FILL

VOLUME
 CUT FILL

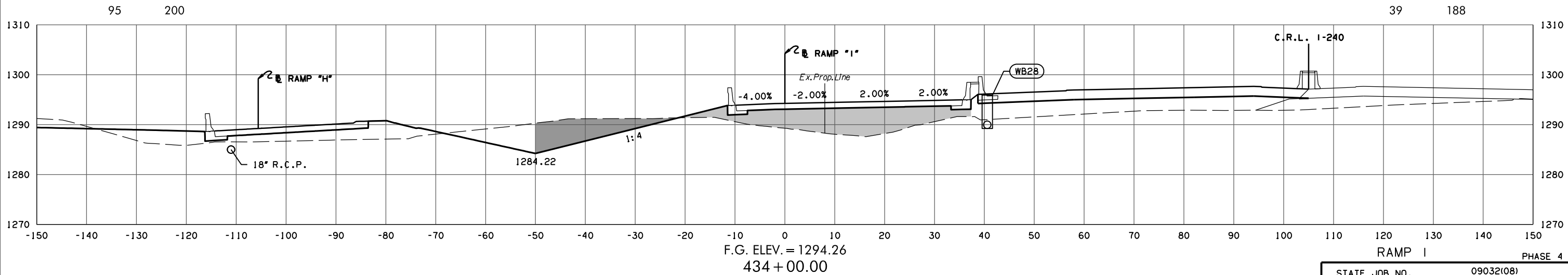
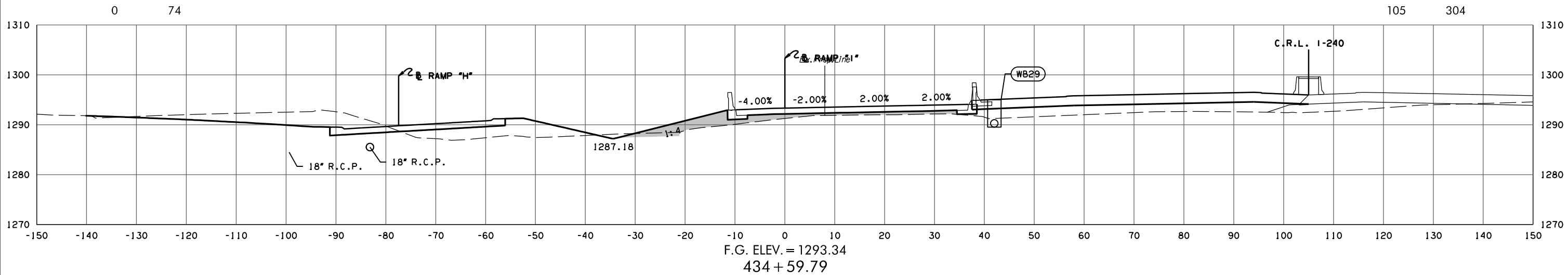
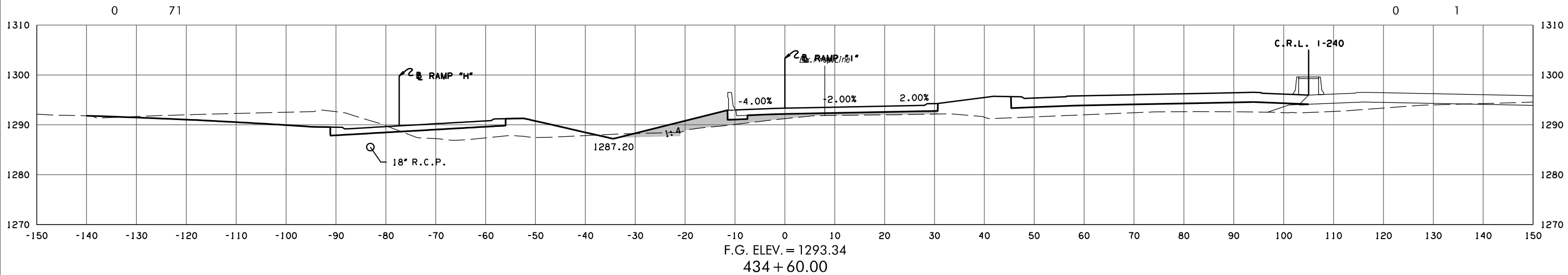

RAMP I PHASE 4
 STATE JOB NO. 09032(08)
 OKLAHOMA COUNTY SHEET NO. X241

3/4/2024 3:59:11 PM
 H:\PROJECTS\2789_CrossRoads_Phase 4\Roadway\Drawings\Sections\0903208-XSEC_Ramp_I.dgn

(CAUTION) THE LOCATION OF ALL UTILITIES AS SHOWN ARE APPROXIMATE. DUE TO RELOCATION'S PLANNED OR PRESENTLY UNDER CONSTRUCTION THERE ARE SOME UTILITIES THAT WILL BE RELOCATED AND NOT SHOWN ON THESE PLANS. THE CONTRACTOR SHALL BE RESPONSIBLE FOR ANY DAMAGE TO ALL UTILITIES.

DEPTH & LOCATION OF EXISTING UTILITIES SHALL BE FIELD VERIFIED BY THE CONTRACTOR PRIOR TO CONSTRUCTION.

SEE DRAINAGE AREA MAP SHEETS FOR DRAINAGE SYMBOLOLOGY.

R/W & U/E PURCHASED UNDER JP 09032(05)

POB & ASSOCIATES, OKLAHOMA CITY, OK.

**90% PLAN
SUBMITTAL**

3/4/2024

AREA
CUT FILL

VOLUME
CUT FILL

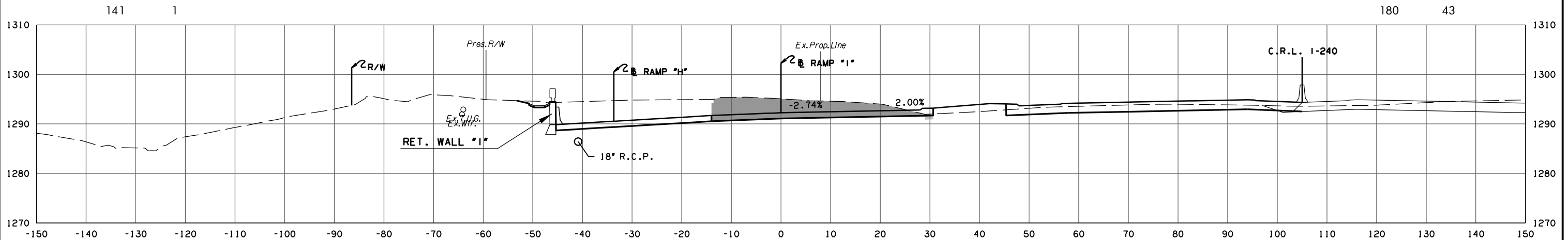

F.G. ELEV. = 1292.26
435 + 85.08

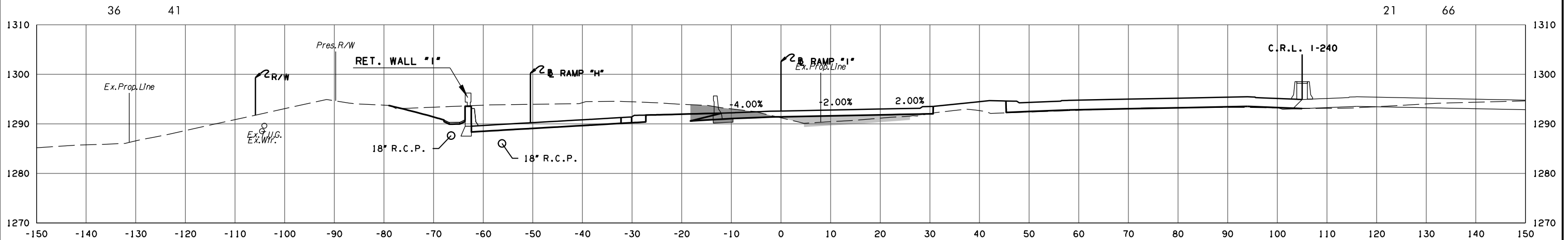

F.G. ELEV. = 1292.59
435 + 30.08

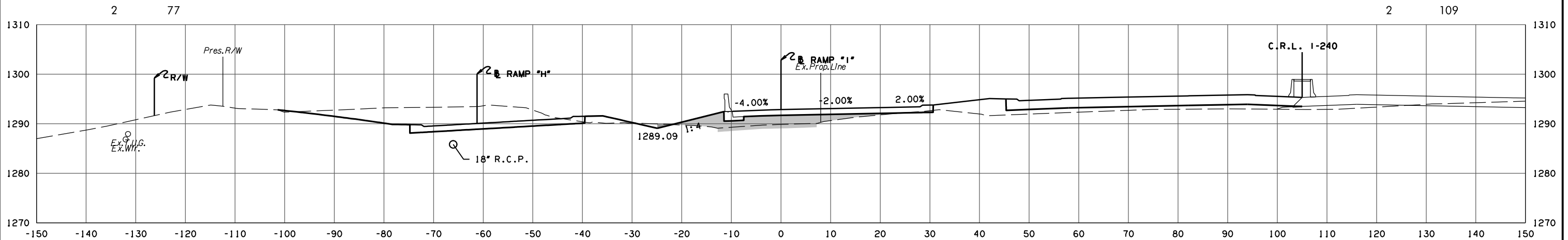

F.G. ELEV. = 1292.87
435 + 00.00

RAMP I PHASE 4

STATE JOB NO. 09032(08)
OKLAHOMA COUNTY SHEET NO. X242

3/4/2024 3:59:11 PM H:\PROJECTS\2789_CrossRoads_Phase 4\Roadway\Drawings\Sections\0903208-XSEC_Ramp_I.dgn

(CAUTION) THE LOCATION OF ALL UTILITIES AS SHOWN ARE APPROXIMATE. DUE TO RELOCATION'S PLANNED OR PRESENTLY UNDER CONSTRUCTION THERE ARE SOME UTILITIES THAT WILL BE RELOCATED AND NOT SHOWN ON THESE PLANS. THE CONTRACTOR SHALL BE RESPONSIBLE FOR ANY DAMAGE TO ALL UTILITIES.

SEE DRAINAGE AREA MAP SHEETS FOR DRAINAGE SYMBOLOLOGY.

R/W & U/E PURCHASED UNDER JP 09032(05)

POB & ASSOCIATES, OKLAHOMA CITY, OK.

90% PLAN SUBMITTAL

3/4/2024

DEPTH & LOCATION OF EXISTING UTILITIES SHALL BE FIELD VERIFIED BY THE CONTRACTOR PRIOR TO CONSTRUCTION.

AREA
CUT FILL

VOLUME
CUT FILL

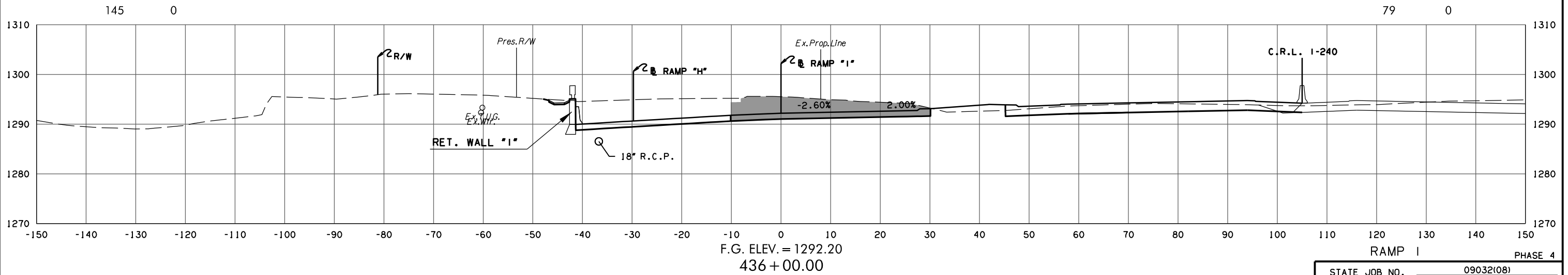
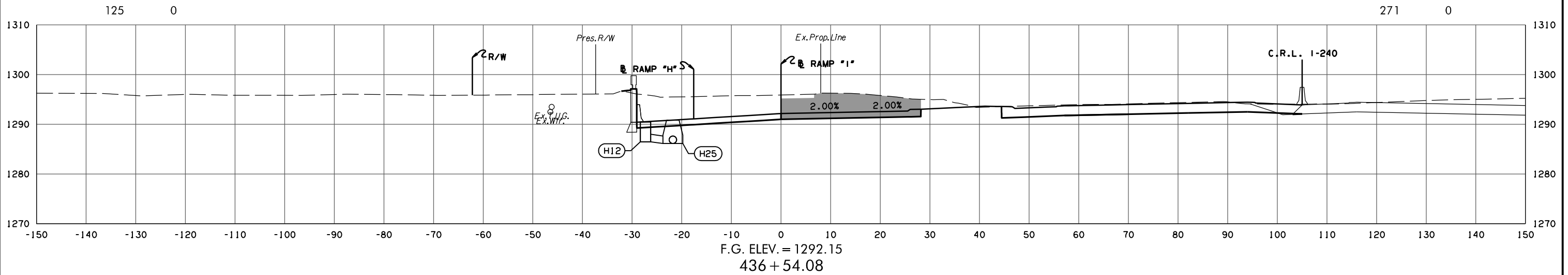
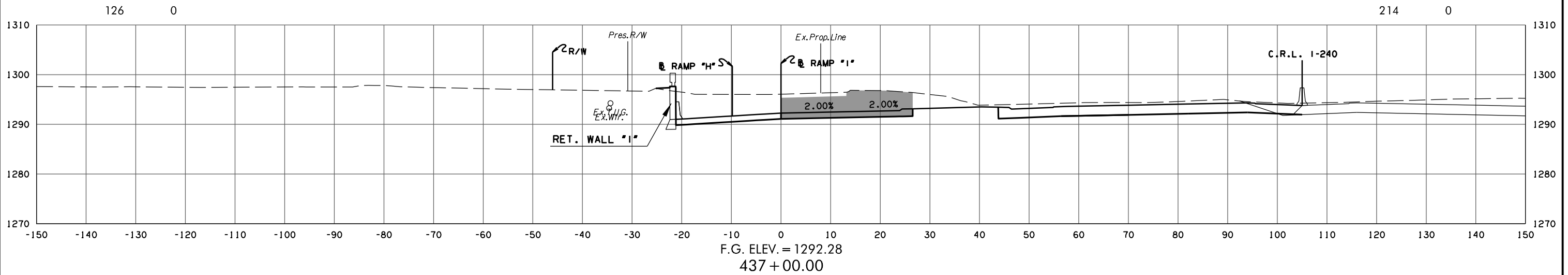

RAMP I PHASE 4

STATE JOB NO. 09032(08)
OKLAHOMA COUNTY SHEET NO. X243

3/4/2024 3:59:19 PM H:\PROJECTS\2789_CrossRoads_Phase 4\Roadway\Drawings\Sections\0903208-XSEC_Ramp_I.dgn

(CAUTION) THE LOCATION OF ALL UTILITIES AS SHOWN ARE APPROXIMATE. DUE TO RELOCATION'S PLANNED OR PRESENTLY UNDER CONSTRUCTION THERE ARE SOME UTILITIES THAT WILL BE RELOCATED AND NOT SHOWN ON THESE PLANS. THE CONTRACTOR SHALL BE RESPONSIBLE FOR ANY DAMAGE TO ALL UTILITIES.

DEPTH & LOCATION OF EXISTING UTILITIES SHALL BE FIELD VERIFIED BY THE CONTRACTOR PRIOR TO CONSTRUCTION.

SEE DRAINAGE AREA MAP SHEETS FOR DRAINAGE SYMBOLOLOGY.

R/W & U/E PURCHASED UNDER JP 09032(05)

POE & ASSOCIATES, OKLAHOMA CITY, OK.

**90% PLAN
SUBMITTAL**

3/4/2024

AREA
CUT FILL

VOLUME
CUT FILL

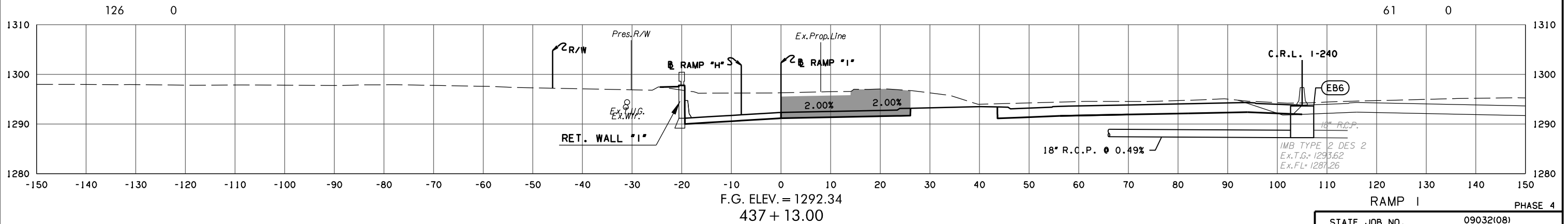
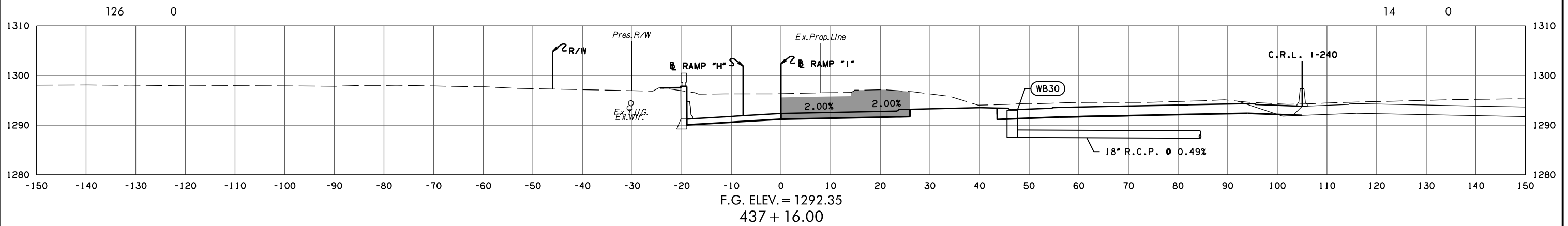
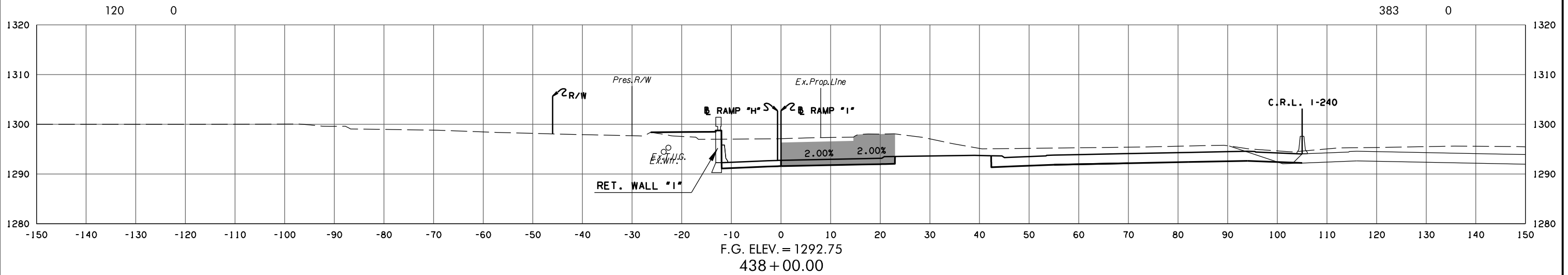

RAMP I PHASE 4

STATE JOB NO. 09032(08)
OKLAHOMA COUNTY SHEET NO. X244

3/4/2024 3:59:49 PM H:\PROJECTS\2789_Crossroads_Phase 4\Roadway\Drawings\Sections\0903208-XSEC_Ramp_I.dgn

(CAUTION) THE LOCATION OF ALL UTILITIES AS SHOWN ARE APPROXIMATE. DUE TO RELOCATION'S PLANNED OR PRESENTLY UNDER CONSTRUCTION THERE ARE SOME UTILITIES THAT WILL BE RELOCATED AND NOT SHOWN ON THESE PLANS. THE CONTRACTOR SHALL BE RESPONSIBLE FOR ANY DAMAGE TO ALL UTILITIES.

DEPTH & LOCATION OF EXISTING UTILITIES SHALL BE FIELD VERIFIED BY THE CONTRACTOR PRIOR TO CONSTRUCTION.

SEE DRAINAGE AREA MAP SHEETS FOR DRAINAGE SYMBOLOLOGY.

R/W & U/E PURCHASED UNDER JP 09032(05)

POB & ASSOCIATES, OKLAHOMA CITY, OK.

**90% PLAN
SUBMITTAL**

3/4/2024

VOLUME
CUT FILL

AREA
CUT FILL

3/4/2024 3:59:20 PM H:\PROJECTS\2785_CrossRoads_Phase 4\Roadway\Drawings\Sections\0903208-XSEC_Ramp_1.dgn

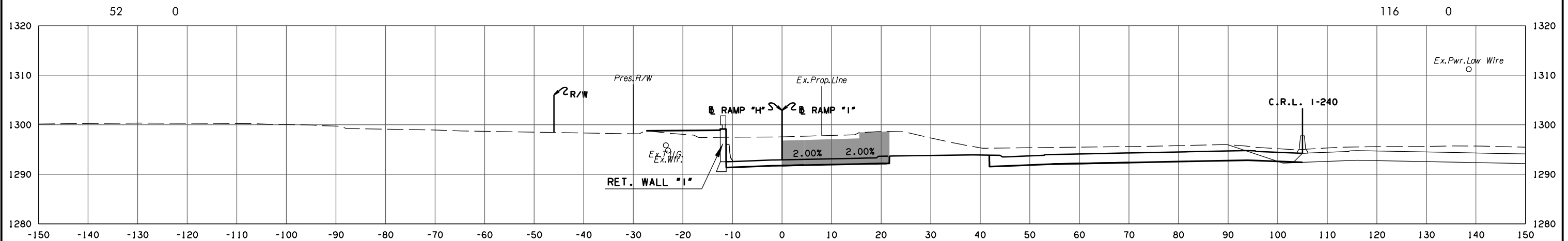

F.G. ELEV. = 1292.93
438 + 36.46
END CONSTRUCTION

STATE JOB NO. 09032(08)
OKLAHOMA COUNTY SHEET NO. X245

(CAUTION) THE LOCATION OF ALL UTILITIES AS SHOWN ARE APPROXIMATE. DUE TO RELOCATION'S PLANNED OR PRESENTLY UNDER CONSTRUCTION THERE ARE SOME UTILITIES THAT WILL BE RELOCATED AND NOT SHOWN ON THESE PLANS. THE CONTRACTOR SHALL BE RESPONSIBLE FOR ANY DAMAGE TO ALL UTILITIES. DEPTH & LOCATION OF EXISTING UTILITIES SHALL BE FIELD VERIFIED BY THE CONTRACTOR PRIOR TO CONSTRUCTION.

SEE DRAINAGE AREA MAP SHEETS FOR DRAINAGE SYMBOLOLOGY.

R/W & U/E PURCHASED UNDER JP 09032(05)

POE & ASSOCIATES, OKLAHOMA CITY, OK.
90% PLAN SUBMITTAL
 3/4/2024

AREA
 CUT FILL

VOLUME
 CUT FILL

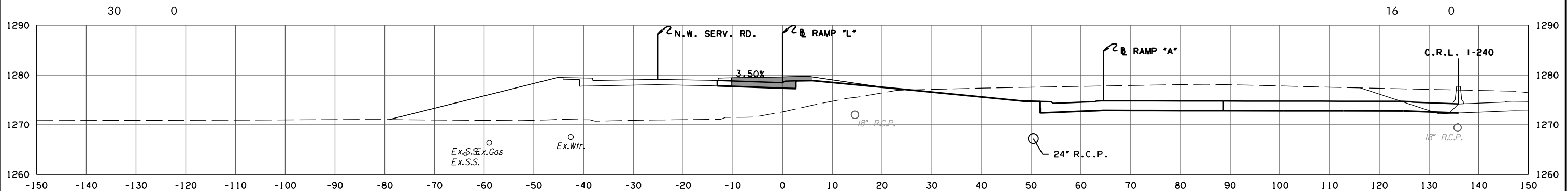

F.G. ELEV. = 1278.46

407 + 73.43

BEGIN FULL SUPER ROTATION

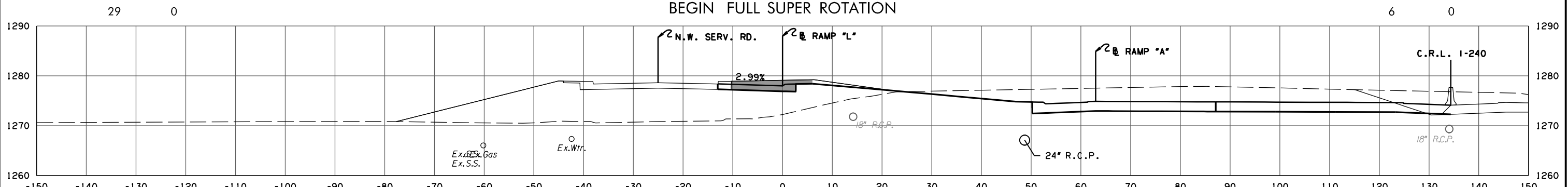

F.G. ELEV. = 1277.98

407 + 58.43

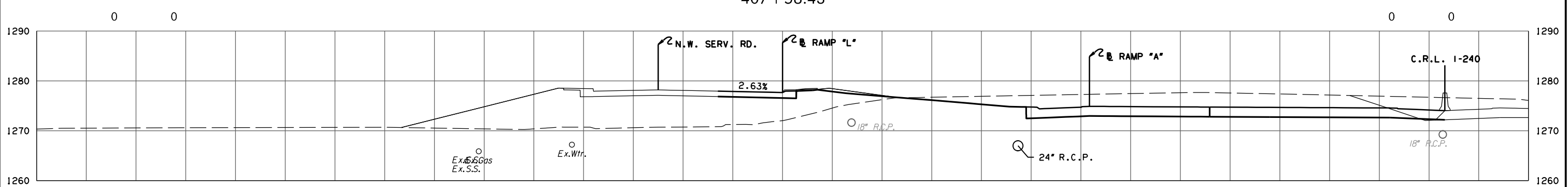

F.G. ELEV. = 1277.62

407 + 47.18

BEGIN CONSTRUCTION BEGIN SUPER ROTATION

RAMP L PHASE 4

STATE JOB NO. 09032(08)
 OKLAHOMA COUNTY SHEET NO. X246

3/4/2024 3:59:21 PM H:\PROJECTS\2789_CrossRoads_Phase 4\Roadway\Drawings\Sections\0903208-XSEC_Ramp-L.dgn

(CAUTION) THE LOCATION OF ALL UTILITIES AS SHOWN ARE APPROXIMATE. DUE TO RELOCATION'S PLANNED OR PRESENTLY UNDER CONSTRUCTION THERE ARE SOME UTILITIES THAT WILL BE RELOCATED AND NOT SHOWN ON THESE PLANS. THE CONTRACTOR SHALL BE RESPONSIBLE FOR ANY DAMAGE TO ALL UTILITIES.

DEPTH & LOCATION OF EXISTING UTILITIES SHALL BE FIELD VERIFIED BY THE CONTRACTOR PRIOR TO CONSTRUCTION.

SEE DRAINAGE AREA MAP SHEETS FOR DRAINAGE SYMBOLOLOGY.

R/W & U/E PURCHASED UNDER JP 09032(05)

POB & ASSOCIATES, OKLAHOMA CITY, OK.

**90% PLAN
SUBMITTAL**

3/4/2024

AREA
CUT FILL

VOLUME
CUT FILL

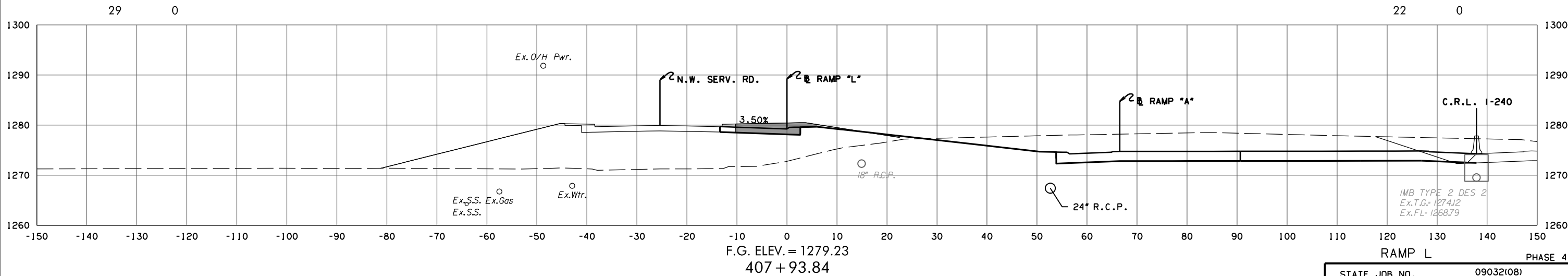
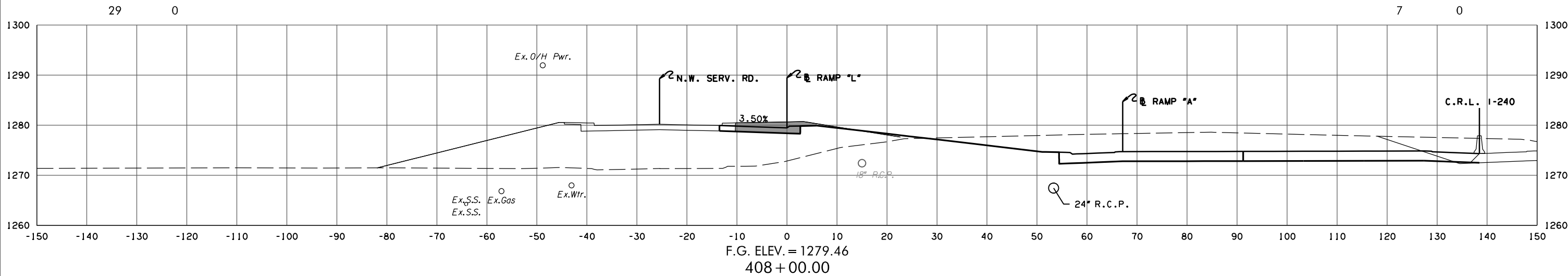
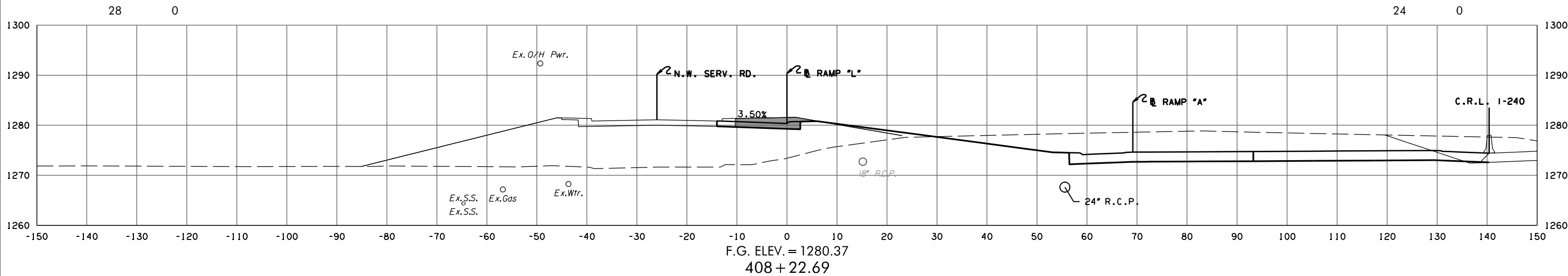

IMB TYPE 2 DES 2
Ex.T.G. 1274.12
Ex.FL 1268.79

RAMP L PHASE 4

STATE JOB NO. 09032(08)
OKLAHOMA COUNTY SHEET NO. X247

3/4/2024 3:59:22 PM H:\PROJECTS\2789_CrossRoads_Phase 4\Roadway\Drawings\Sections\0903208-XSEC_Ramp-L.dgn

(CAUTION) THE LOCATION OF ALL UTILITIES AS SHOWN ARE APPROXIMATE. DUE TO RELOCATION'S PLANNED OR PRESENTLY UNDER CONSTRUCTION THERE ARE SOME UTILITIES THAT WILL BE RELOCATED AND NOT SHOWN ON THESE PLANS. THE CONTRACTOR SHALL BE RESPONSIBLE FOR ANY DAMAGE TO ALL UTILITIES.

DEPTH & LOCATION OF EXISTING UTILITIES SHALL BE FIELD VERIFIED BY THE CONTRACTOR PRIOR TO CONSTRUCTION.

SEE DRAINAGE AREA MAP SHEETS FOR DRAINAGE SYMBOLOLOGY.

R/W & U/E PURCHASED UNDER JP 09032(05)

POB & ASSOCIATES, OKLAHOMA CITY, OK

**90% PLAN
SUBMITTAL**

3/4/2024

AREA
CUT FILL

VOLUME
CUT FILL

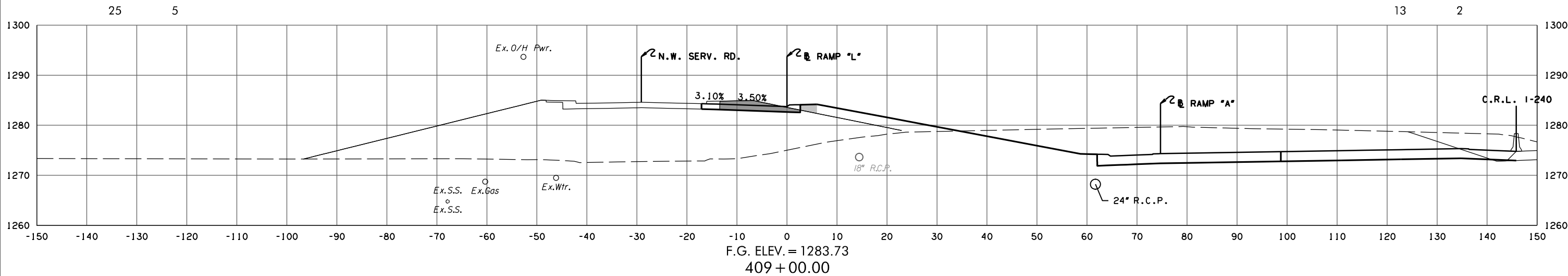

F.G. ELEV. = 1283.73
409 + 00.00

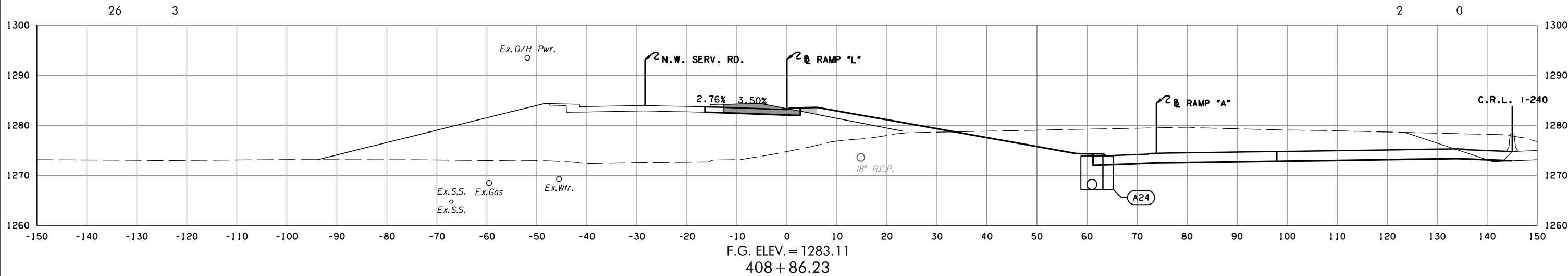

F.G. ELEV. = 1283.11
408 + 86.23

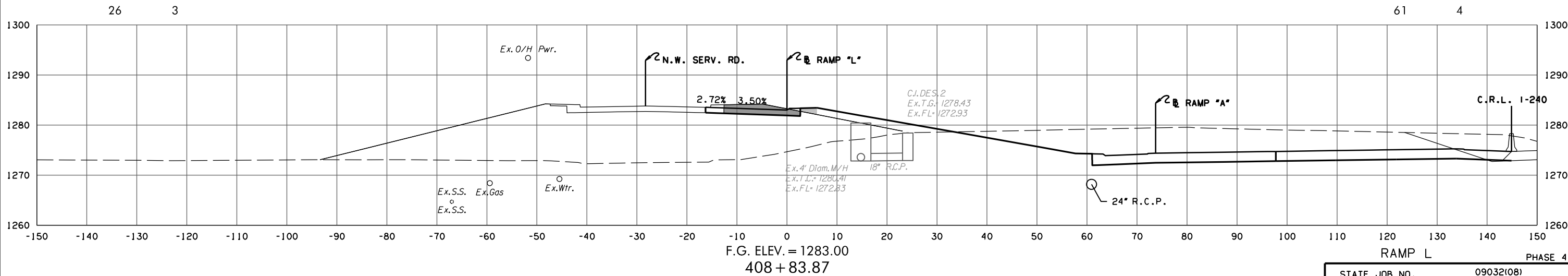

F.G. ELEV. = 1283.00
408 + 83.87

RAMP L PHASE 4

STATE JOB NO. 09032(08)
OKLAHOMA COUNTY SHEET NO. X248

3/4/2024 3:59:23 PM H:\PROJECTS\2789_CrossRoads_Phase 4\Roadway\Drawings\Sections\XSections\0903208-XSEC_Ramp_L.dgn

(CAUTION) THE LOCATION OF ALL UTILITIES AS SHOWN ARE APPROXIMATE. DUE TO RELOCATION'S PLANNED OR PRESENTLY UNDER CONSTRUCTION THERE ARE SOME UTILITIES THAT WILL BE RELOCATED AND NOT SHOWN ON THESE PLANS. THE CONTRACTOR SHALL BE RESPONSIBLE FOR ANY DAMAGE TO ALL UTILITIES.
 DEPTH & LOCATION OF EXISTING UTILITIES SHALL BE FIELD VERIFIED BY THE CONTRACTOR PRIOR TO CONSTRUCTION.

SEE DRAINAGE AREA MAP SHEETS FOR DRAINAGE SYMBOLOLOGY.

R/W & U/E PURCHASED UNDER JP 09032(05)

POB & ASSOCIATES, OKLAHOMA CITY, OK.
90% PLAN SUBMITTAL
 3/4/2024

AREA
 CUT FILL

VOLUME
 CUT FILL

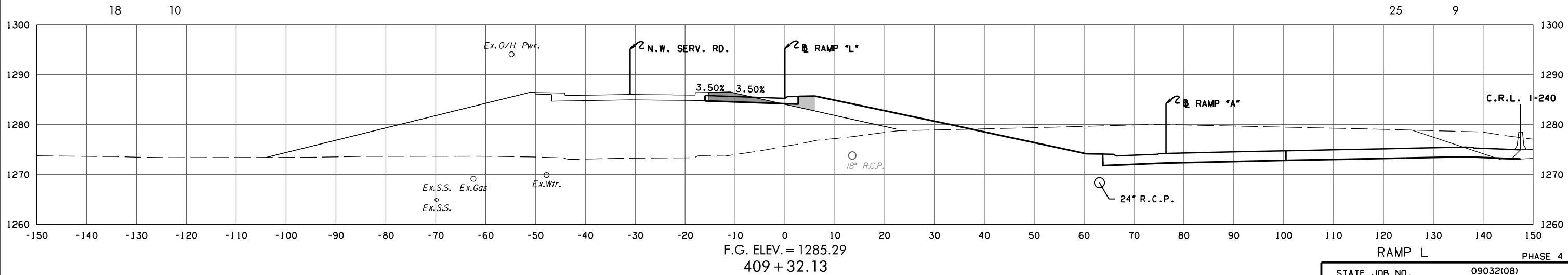
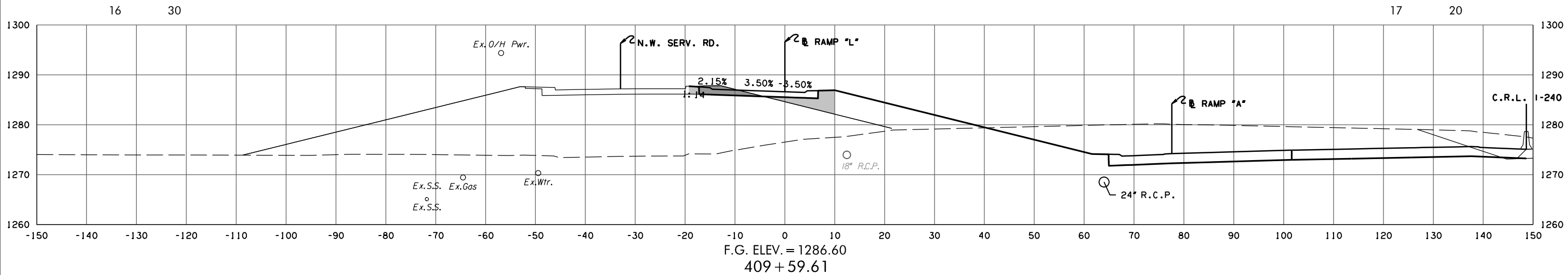
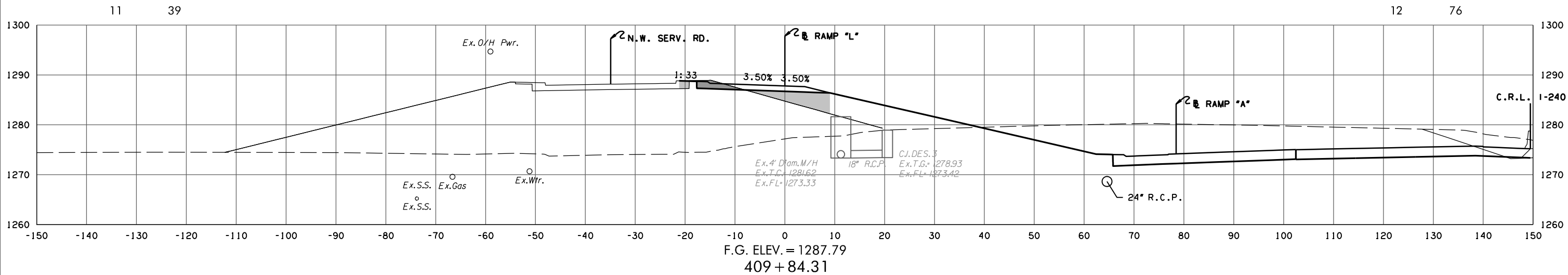

3/4/2024 3:59:24 PM H:\PROJECTS\2789_CrossRoads_Phase 4\Roadway\Drawings\Sections\0903208-XSEC_Ramp_L.dgn

RAMP L PHASE 4
 STATE JOB NO. 09032(08)
 OKLAHOMA COUNTY SHEET NO. X249

(CAUTION) THE LOCATION OF ALL UTILITIES AS SHOWN ARE APPROXIMATE. DUE TO RELOCATION'S PLANNED OR PRESENTLY UNDER CONSTRUCTION THERE ARE SOME UTILITIES THAT WILL BE RELOCATED AND NOT SHOWN ON THESE PLANS. THE CONTRACTOR SHALL BE RESPONSIBLE FOR ANY DAMAGE TO ALL UTILITIES.
 DEPTH & LOCATION OF EXISTING UTILITIES SHALL BE FIELD VERIFIED BY THE CONTRACTOR PRIOR TO CONSTRUCTION.

SEE DRAINAGE AREA MAP SHEETS FOR DRAINAGE SYMBOLOLOGY.

R/W & U/E PURCHASED UNDER JP 09032(05)

POB & ASSOCIATES, OKLAHOMA CITY, OK.
90% PLAN SUBMITTAL
 3/4/2024

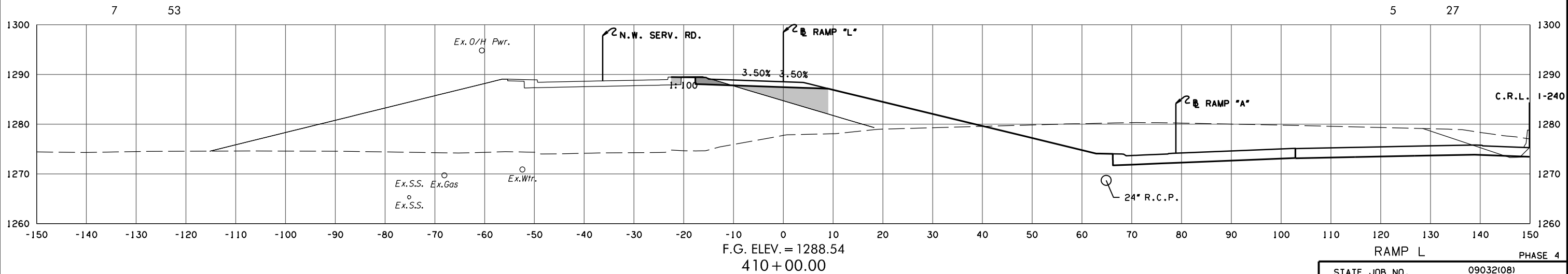
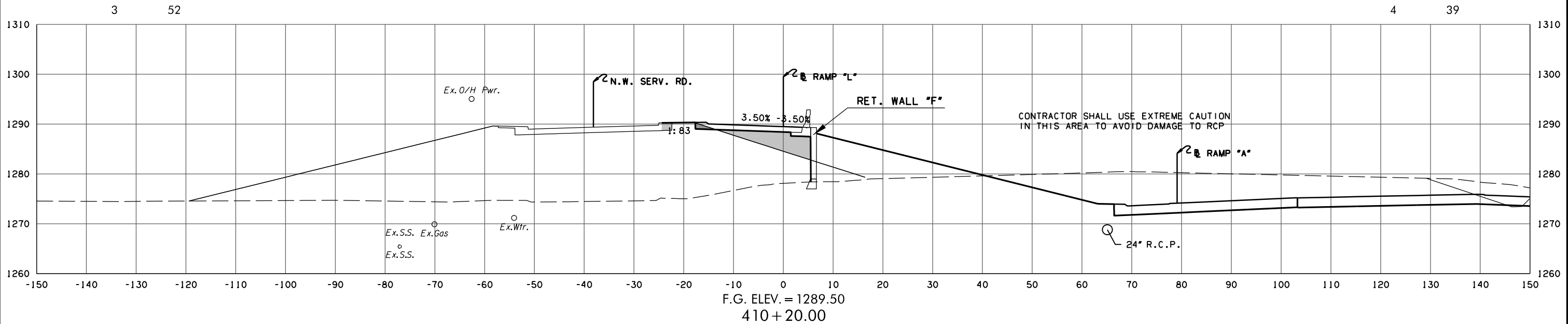
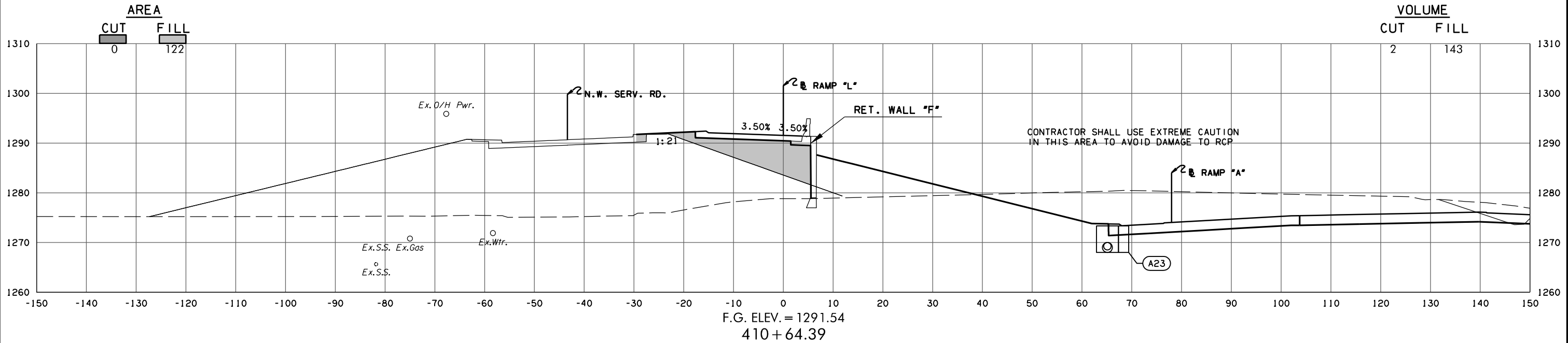

3/4/2024 3:59:25 PM H:\PROJECTS\2789_CrossRoads_Phase 4\Roadway\Drawings\Sections\0903208-XSEC_Ramp-L.dgn

RAMP L PHASE 4
 STATE JOB NO. 09032(08)
 OKLAHOMA COUNTY SHEET NO. X250

(CAUTION) THE LOCATION OF ALL UTILITIES AS SHOWN ARE APPROXIMATE. DUE TO RELOCATION'S PLANNED OR PRESENTLY UNDER CONSTRUCTION THERE ARE SOME UTILITIES THAT WILL BE RELOCATED AND NOT SHOWN ON THESE PLANS. THE CONTRACTOR SHALL BE RESPONSIBLE FOR ANY DAMAGE TO ALL UTILITIES.
 DEPTH & LOCATION OF EXISTING UTILITIES SHALL BE FIELD VERIFIED BY THE CONTRACTOR PRIOR TO CONSTRUCTION.



SEE DRAINAGE AREA MAP SHEETS FOR DRAINAGE SYMBOLOLOGY.

R/W & U/E PURCHASED UNDER JP 09032(05)

POB & ASSOCIATES, OKLAHOMA CITY, OK.

90% PLAN SUBMITTAL

3/4/2024

AREA
 CUT  FILL 

VOLUME
 CUT FILL

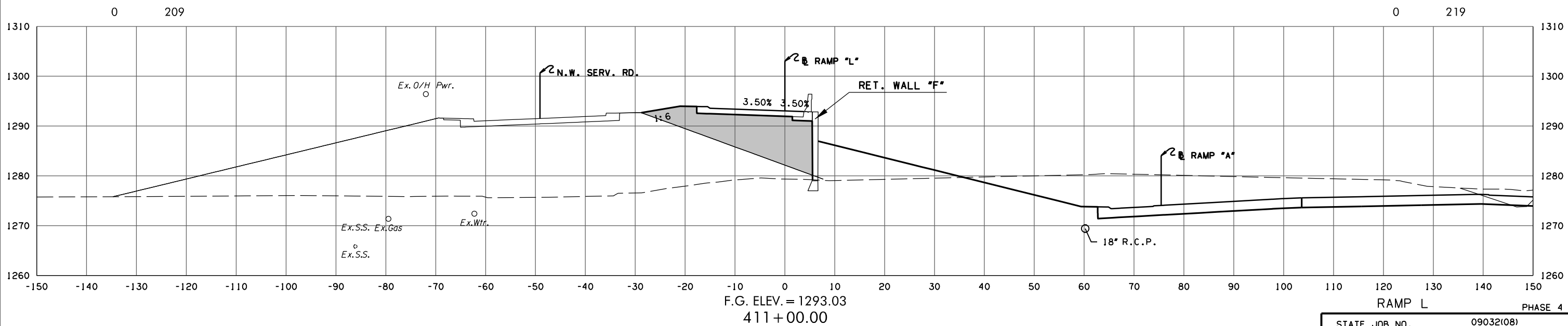
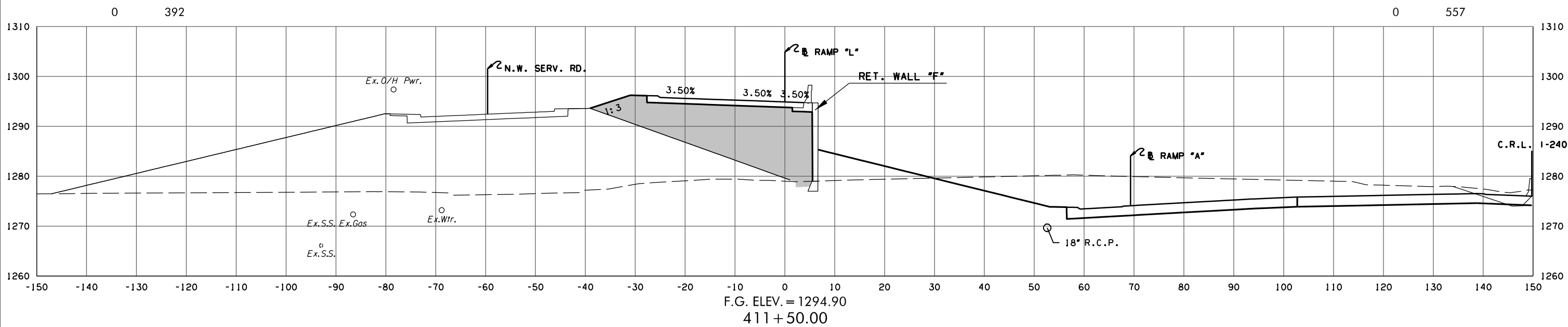

3/4/2024 3:59:25 PM H:\PROJECTS\2789_CrossRoads_Phase 4\Roadway\Drawings\Sections\0903208-XSEC_Ramp_L.dgn

(CAUTION) THE LOCATION OF ALL UTILITIES AS SHOWN ARE APPROXIMATE. DUE TO RELOCATION'S PLANNED OR PRESENTLY UNDER CONSTRUCTION THERE ARE SOME UTILITIES THAT WILL BE RELOCATED AND NOT SHOWN ON THESE PLANS. THE CONTRACTOR SHALL BE RESPONSIBLE FOR ANY DAMAGE TO ALL UTILITIES.
 DEPTH & LOCATION OF EXISTING UTILITIES SHALL BE FIELD VERIFIED BY THE CONTRACTOR PRIOR TO CONSTRUCTION.

SEE DRAINAGE AREA MAP SHEETS FOR DRAINAGE SYMBOLOLOGY.

R/W & U/E PURCHASED UNDER JP 09032(05)

POB & ASSOCIATES, OKLAHOMA CITY, OK.
90% PLAN SUBMITTAL
 3/4/2024

AREA
 CUT FILL

VOLUME
 CUT FILL

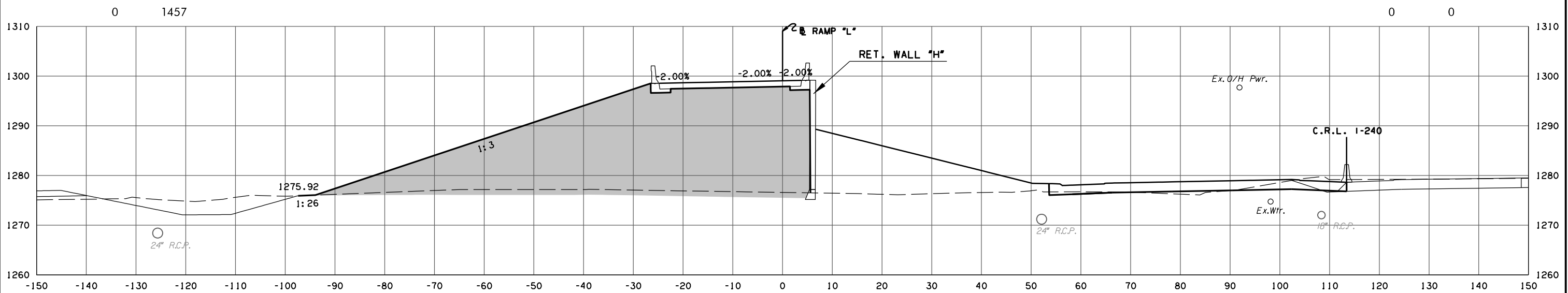

F.G. ELEV. = 1299.06

416+70.42

BEGIN SHOULDER ROTATION END APPROACH SLAB

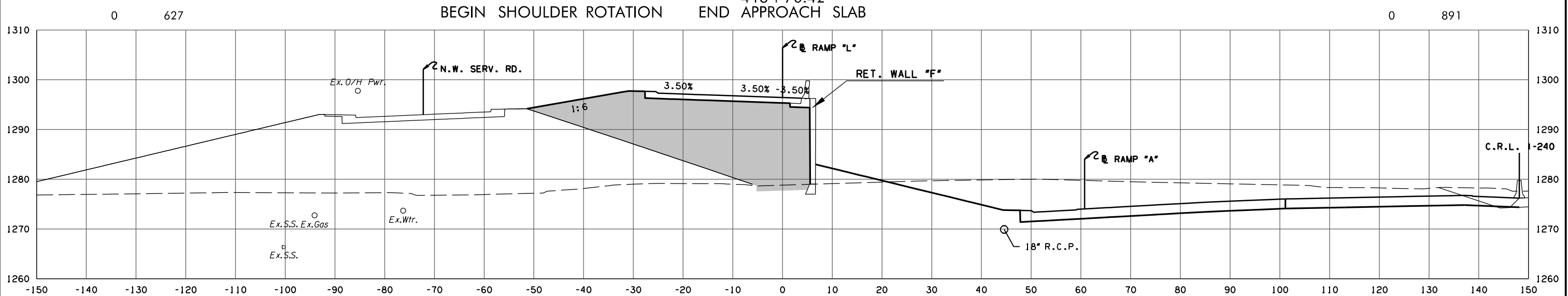

F.G. ELEV. = 1296.42

411+96.92

BEGIN APPROACH SLAB END FULL SUPER ROTATION STA. 412+67.41

RAMP L PHASE 4

STATE JOB NO. 09032(08)
 OKLAHOMA COUNTY SHEET NO. X252



3/4/2024 3:59:26 PM H:\PROJECTS\2789_CrossRoads_Phase 4\Roadway\Drawings\Sections\0903208-XSEC_Ramp_L.dgn

(CAUTION) THE LOCATION OF ALL UTILITIES AS SHOWN ARE APPROXIMATE. DUE TO RELOCATION'S PLANNED OR PRESENTLY UNDER CONSTRUCTION THERE ARE SOME UTILITIES THAT WILL BE RELOCATED AND NOT SHOWN ON THESE PLANS. THE CONTRACTOR SHALL BE RESPONSIBLE FOR ANY DAMAGE TO ALL UTILITIES.
 DEPTH & LOCATION OF EXISTING UTILITIES SHALL BE FIELD VERIFIED BY THE CONTRACTOR PRIOR TO CONSTRUCTION.

SEE DRAINAGE AREA MAP SHEETS FOR DRAINAGE SYMBOLOLOGY.

R/W & U/E PURCHASED UNDER JP 09032(05)

POB & ASSOCIATES, OKLAHOMA CITY, OK.
90% PLAN SUBMITTAL
 3/4/2024

AREA
 CUT  FILL 

VOLUME
 CUT FILL

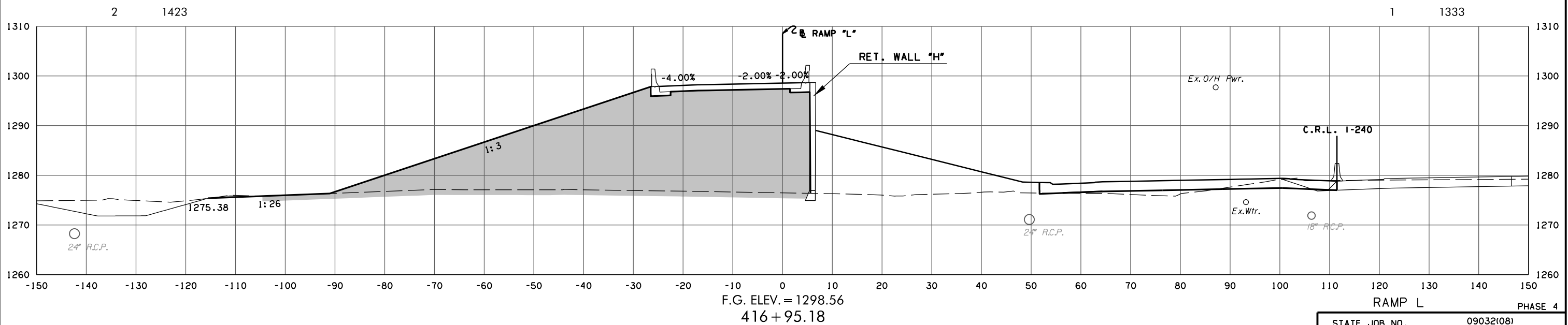
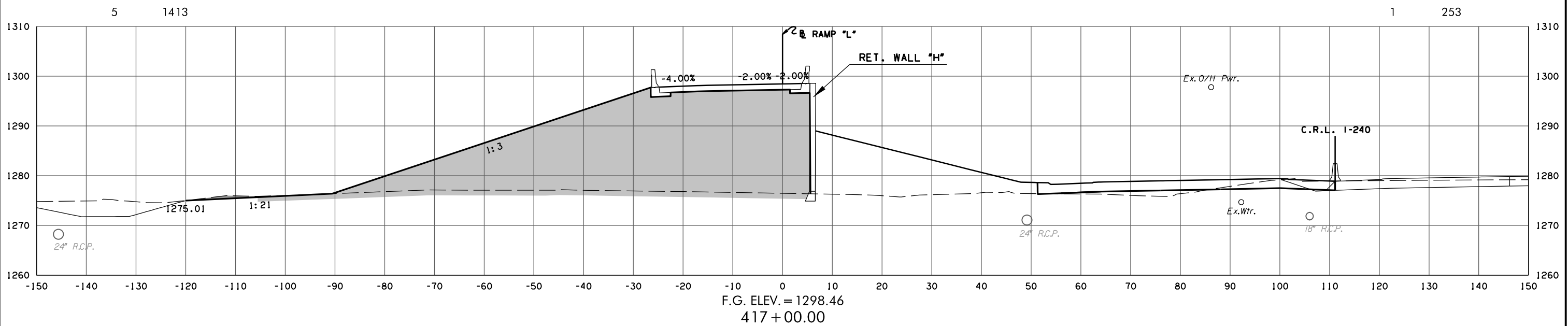

END SHOULDER ROTATION

RAMP L PHASE 4
 STATE JOB NO. 09032(08)
 OKLAHOMA COUNTY SHEET NO. X253



3/4/2024 3:59:27 PM
 H:\PROJECTS\2785_CrossRoads_Phase 4\Roadway\Drawings\Sections\0903208-XSEC_Ramp_L.dgn

(CAUTION) THE LOCATION OF ALL UTILITIES AS SHOWN ARE APPROXIMATE. DUE TO RELOCATION'S PLANNED OR PRESENTLY UNDER CONSTRUCTION THERE ARE SOME UTILITIES THAT WILL BE RELOCATED AND NOT SHOWN ON THESE PLANS. THE CONTRACTOR SHALL BE RESPONSIBLE FOR ANY DAMAGE TO ALL UTILITIES.
 DEPTH & LOCATION OF EXISTING UTILITIES SHALL BE FIELD VERIFIED BY THE CONTRACTOR PRIOR TO CONSTRUCTION.

SEE DRAINAGE AREA MAP SHEETS FOR DRAINAGE SYMBOLOLOGY.

R/W & U/E PURCHASED UNDER JP 09032(05)

POB & ASSOCIATES, OKLAHOMA CITY, OK.
90% PLAN SUBMITTAL
 3/4/2024

AREA
 CUT  FILL 

VOLUME
 CUT FILL

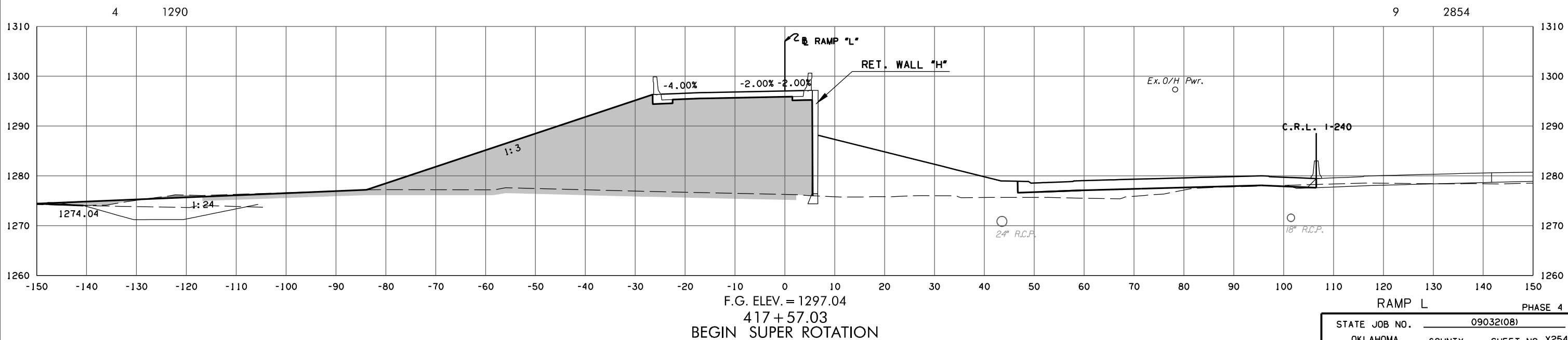
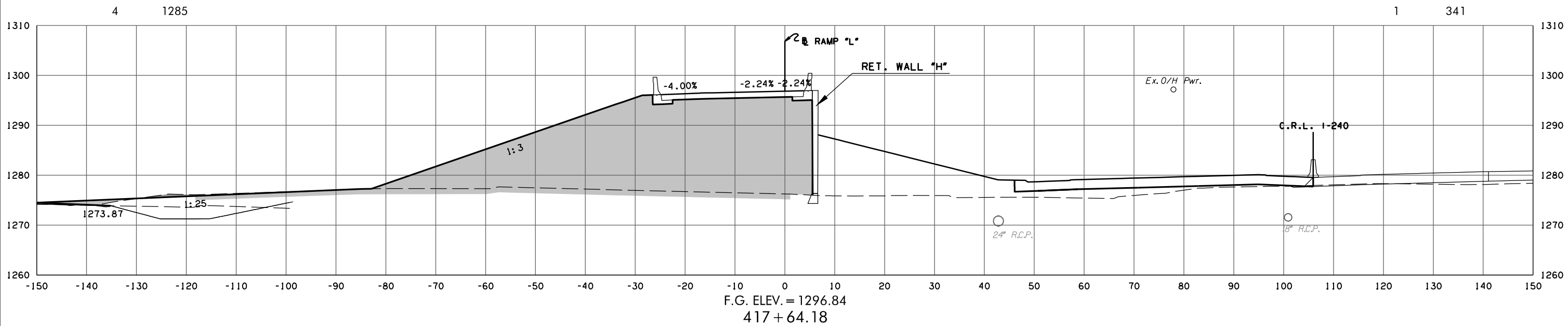

3/4/2024 3:59:28 PM
 H:\PROJECTS\2789_CrossRoads_Phase 4\Roadway\Drawings\Sections\0903208-XSEC_Ramp_L.dgn



STATE JOB NO. 09032(08)
 OKLAHOMA COUNTY SHEET NO. X254

(CAUTION) THE LOCATION OF ALL UTILITIES AS SHOWN ARE APPROXIMATE. DUE TO RELOCATION'S PLANNED OR PRESENTLY UNDER CONSTRUCTION THERE ARE SOME UTILITIES THAT WILL BE RELOCATED AND NOT SHOWN ON THESE PLANS. THE CONTRACTOR SHALL BE RESPONSIBLE FOR ANY DAMAGE TO ALL UTILITIES.
 DEPTH & LOCATION OF EXISTING UTILITIES SHALL BE FIELD VERIFIED BY THE CONTRACTOR PRIOR TO CONSTRUCTION.

SEE DRAINAGE AREA MAP SHEETS FOR DRAINAGE SYMBOLOLOGY.

R/W & U/E PURCHASED UNDER JP 09032(05)

POB & ASSOCIATES, OKLAHOMA CITY, OK.
90% PLAN SUBMITTAL
 3/4/2024

AREA
 CUT  FILL 

VOLUME
 CUT FILL

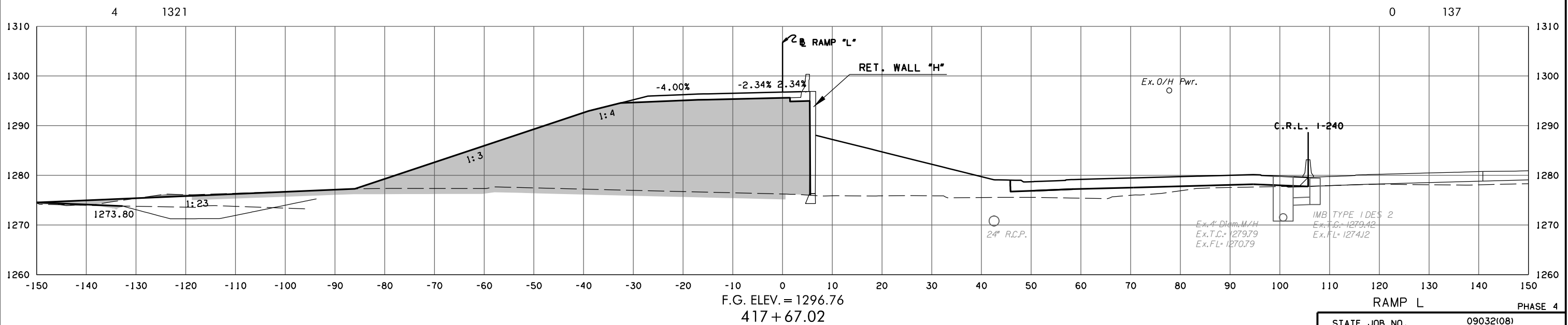
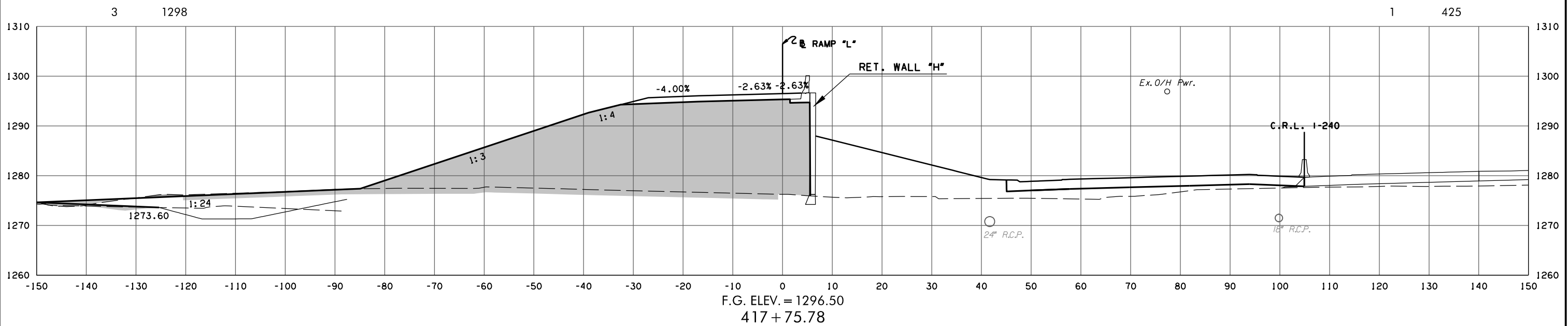

STATE JOB NO. 09032(08)
 OKLAHOMA COUNTY SHEET NO. X255

3/4/2024 3:59:29 PM H:\PROJECTS\2789_CrossRoads_Phase 4\Roadway\Drawings\Sections\0903208-XSEC_Ramp_L.dgn

(CAUTION) THE LOCATION OF ALL UTILITIES AS SHOWN ARE APPROXIMATE. DUE TO RELOCATION'S PLANNED OR PRESENTLY UNDER CONSTRUCTION THERE ARE SOME UTILITIES THAT WILL BE RELOCATED AND NOT SHOWN ON THESE PLANS. THE CONTRACTOR SHALL BE RESPONSIBLE FOR ANY DAMAGE TO ALL UTILITIES.
 DEPTH & LOCATION OF EXISTING UTILITIES SHALL BE FIELD VERIFIED BY THE CONTRACTOR PRIOR TO CONSTRUCTION.

SEE DRAINAGE AREA MAP SHEETS FOR DRAINAGE SYMBOLOLOGY.

R/W & U/E PURCHASED UNDER JP 09032(05)

POB & ASSOCIATES, OKLAHOMA CITY, OK.
90% PLAN SUBMITTAL
 3/4/2024

AREA
 CUT FILL

VOLUME
 CUT FILL

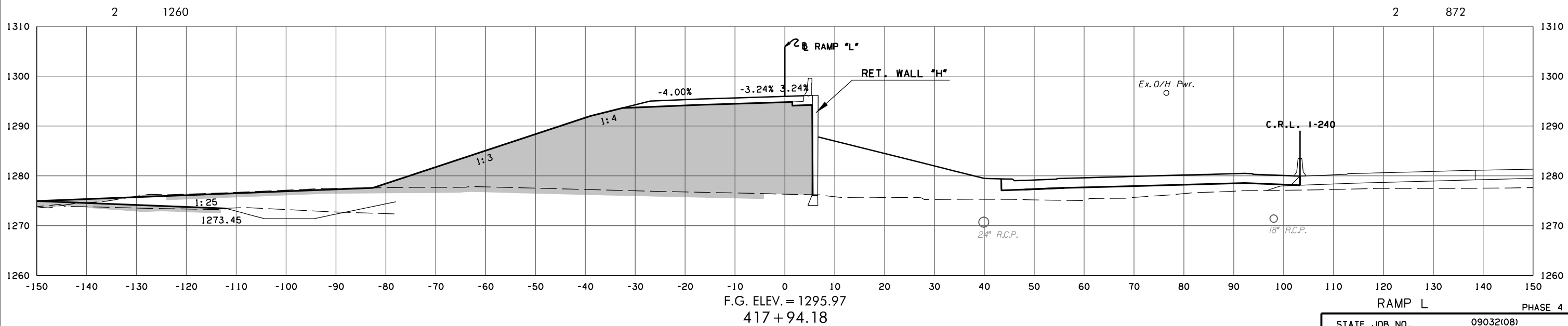
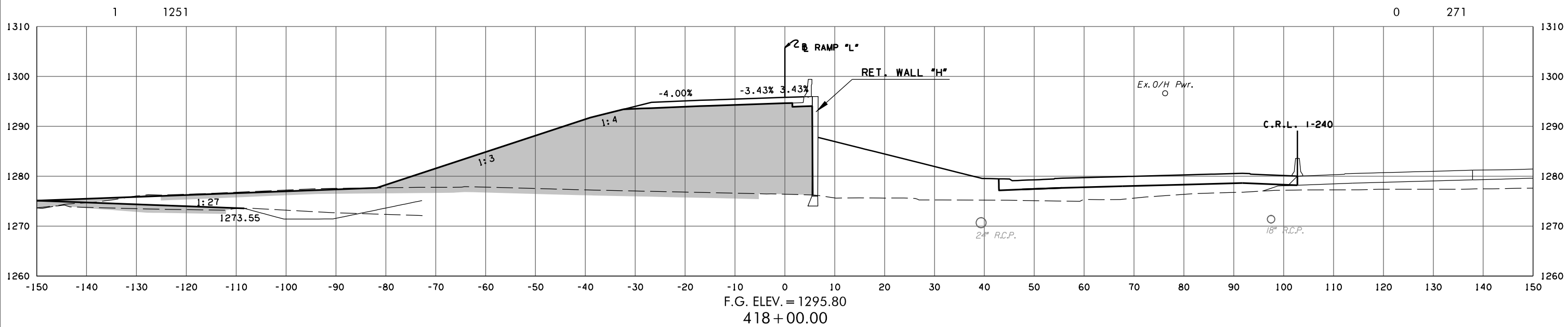

STATE JOB NO. 09032(08)
 OKLAHOMA COUNTY SHEET NO. X256

3/4/2024 3:59:29 PM
 H:\PROJECTS\2789_CrossRoads_Phase 4\Roadway\Drawings\Sections\0903208-XSEC_Ramp_L.dgn

(CAUTION) THE LOCATION OF ALL UTILITIES AS SHOWN ARE APPROXIMATE. DUE TO RELOCATION'S PLANNED OR PRESENTLY UNDER CONSTRUCTION THERE ARE SOME UTILITIES THAT WILL BE RELOCATED AND NOT SHOWN ON THESE PLANS. THE CONTRACTOR SHALL BE RESPONSIBLE FOR ANY DAMAGE TO ALL UTILITIES.
 DEPTH & LOCATION OF EXISTING UTILITIES SHALL BE FIELD VERIFIED BY THE CONTRACTOR PRIOR TO CONSTRUCTION.

SEE DRAINAGE AREA MAP SHEETS FOR DRAINAGE SYMBOLOLOGY.

R/W & U/E PURCHASED UNDER JP 09032(05)

POB & ASSOCIATES, OKLAHOMA CITY, OK.
90% PLAN SUBMITTAL
 3/4/2024

AREA
 CUT FILL

VOLUME
 CUT FILL

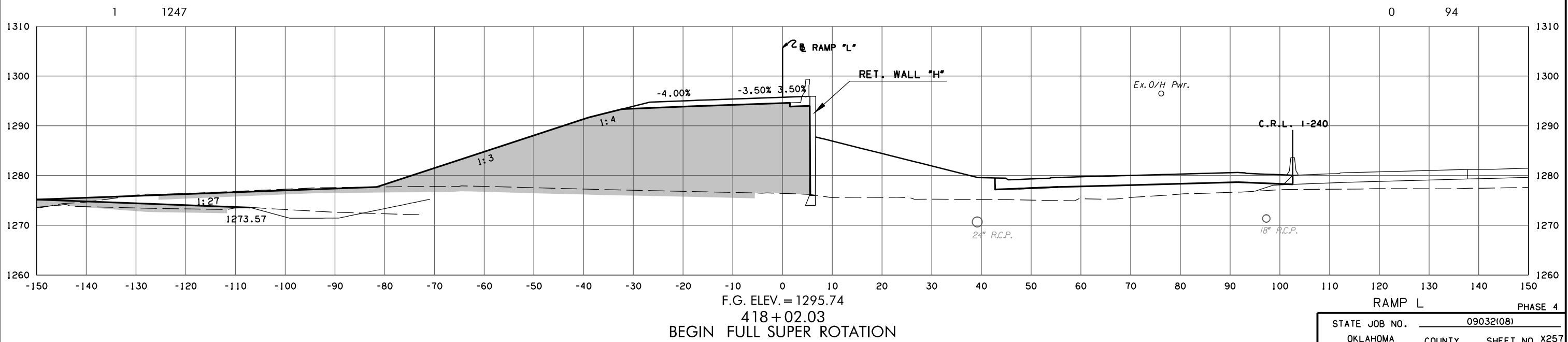
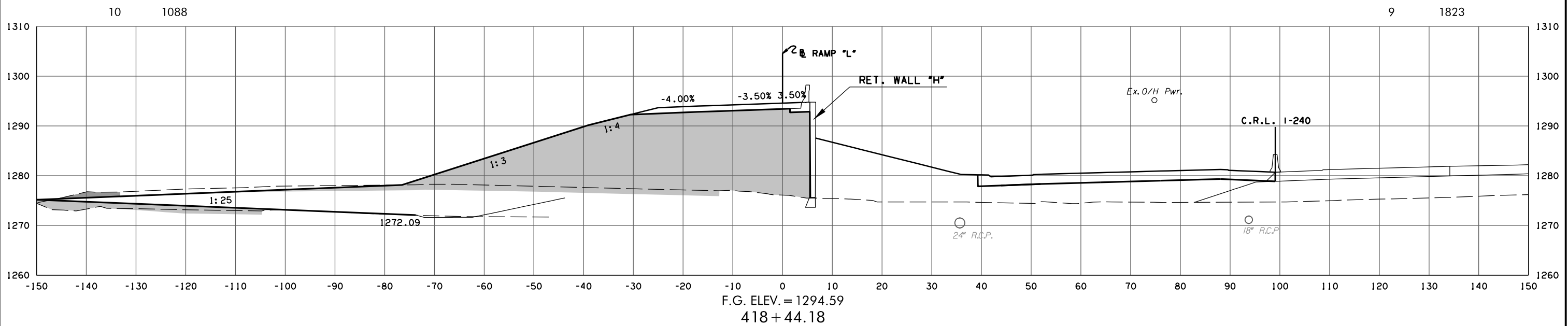

RAMP L PHASE 4
 STATE JOB NO. 09032(08)
 OKLAHOMA COUNTY SHEET NO. X257

3/4/2024 3:59:30 PM
 H:\PROJECTS\2789_CrossRoads_Phase 4\Roadway\Drawings\Sections\0903208-XSEC_Ramp_L.dgn

(CAUTION) THE LOCATION OF ALL UTILITIES AS SHOWN ARE APPROXIMATE. DUE TO RELOCATION'S PLANNED OR PRESENTLY UNDER CONSTRUCTION THERE ARE SOME UTILITIES THAT WILL BE RELOCATED AND NOT SHOWN ON THESE PLANS. THE CONTRACTOR SHALL BE RESPONSIBLE FOR ANY DAMAGE TO ALL UTILITIES.
 DEPTH & LOCATION OF EXISTING UTILITIES SHALL BE FIELD VERIFIED BY THE CONTRACTOR PRIOR TO CONSTRUCTION.

SEE DRAINAGE AREA MAP SHEETS FOR DRAINAGE SYMBOLOLOGY.

R/W & U/E PURCHASED UNDER JP 09032(05)

POB & ASSOCIATES, OKLAHOMA CITY, OK.
90% PLAN SUBMITTAL
 3/4/2024

AREA
 CUT FILL

VOLUME
 CUT FILL

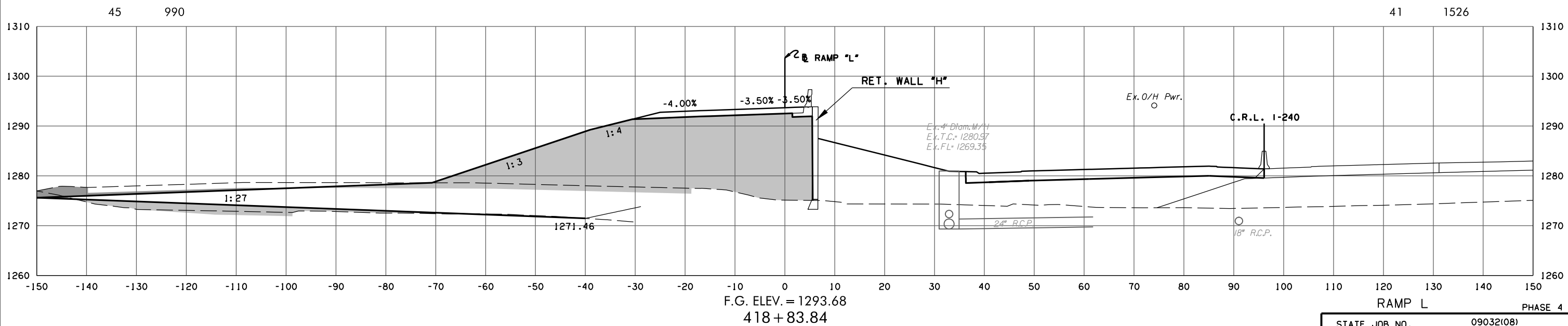
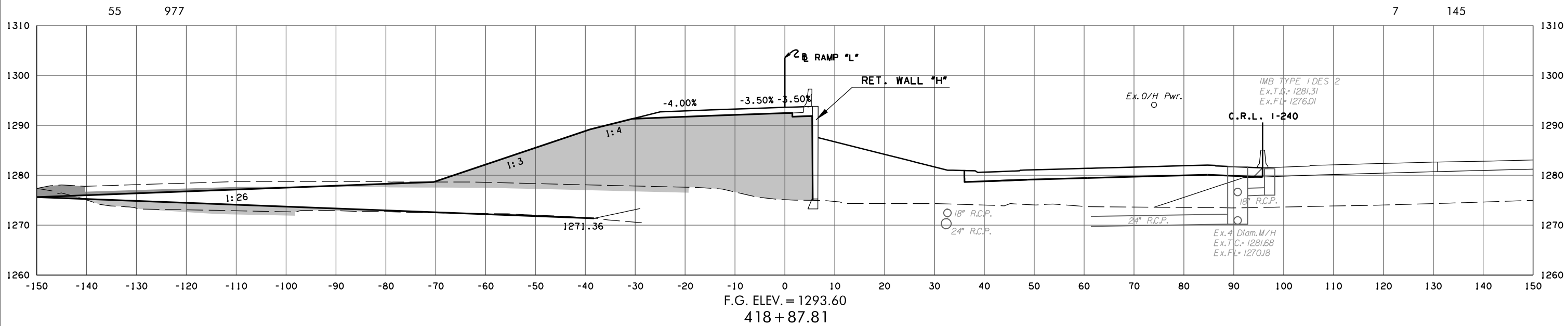

RAMP L PHASE 4
 STATE JOB NO. 09032(08)
 OKLAHOMA COUNTY SHEET NO. X258

3/4/2024 3:59:31 PM H:\PROJECTS\2789_CrossRoads_Phase 4\Roadway\Drawings\Sections\0903208-XSEC_Ramp_L.dgn

(CAUTION) THE LOCATION OF ALL UTILITIES AS SHOWN ARE APPROXIMATE. DUE TO RELOCATION'S PLANNED OR PRESENTLY UNDER CONSTRUCTION THERE ARE SOME UTILITIES THAT WILL BE RELOCATED AND NOT SHOWN ON THESE PLANS. THE CONTRACTOR SHALL BE RESPONSIBLE FOR ANY DAMAGE TO ALL UTILITIES.
 DEPTH & LOCATION OF EXISTING UTILITIES SHALL BE FIELD VERIFIED BY THE CONTRACTOR PRIOR TO CONSTRUCTION.

SEE DRAINAGE AREA MAP SHEETS FOR DRAINAGE SYMBOLOLOGY.

R/W & U/E PURCHASED UNDER JP 09032(05)

POB & ASSOCIATES, OKLAHOMA CITY, OK.
90% PLAN SUBMITTAL
 3/4/2024

AREA
 CUT FILL

VOLUME
 CUT FILL

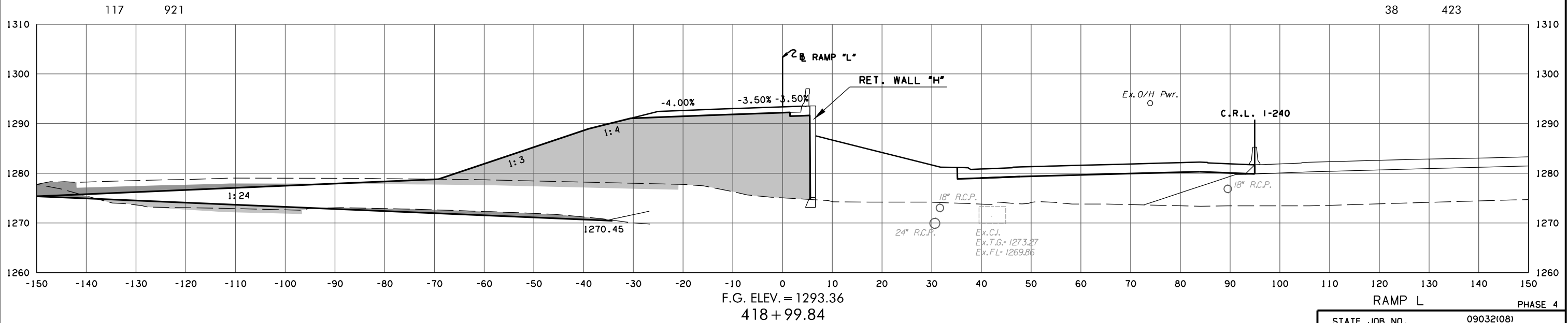
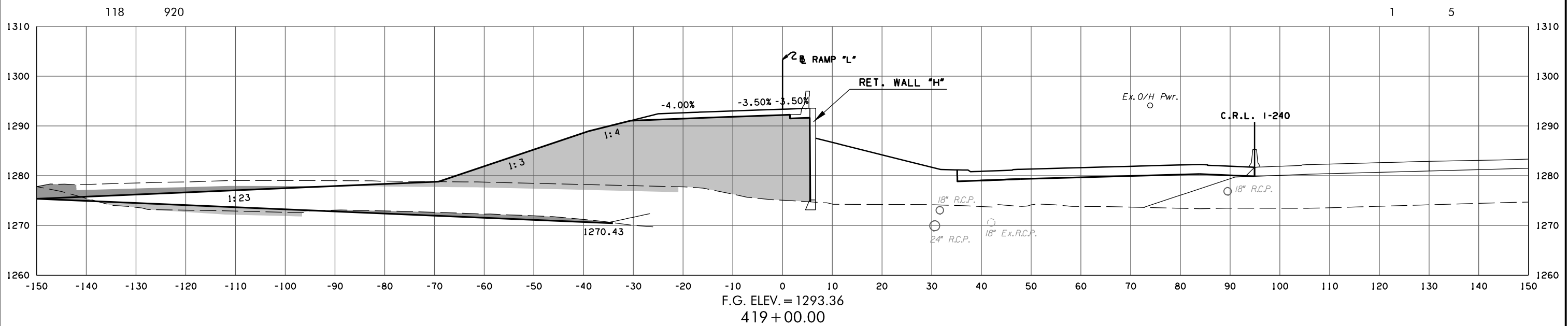

3/4/2024 3:59:32 PM H:\PROJECTS\2789_CrossRoads_Phase 4\Roadway\Drawings\Sections\0903208-XSEC_Ramp_L.dgn

STATE JOB NO. 09032(08)
 OKLAHOMA COUNTY SHEET NO. X259

(CAUTION) THE LOCATION OF ALL UTILITIES AS SHOWN ARE APPROXIMATE. DUE TO RELOCATION'S PLANNED OR PRESENTLY UNDER CONSTRUCTION THERE ARE SOME UTILITIES THAT WILL BE RELOCATED AND NOT SHOWN ON THESE PLANS. THE CONTRACTOR SHALL BE RESPONSIBLE FOR ANY DAMAGE TO ALL UTILITIES.
 DEPTH & LOCATION OF EXISTING UTILITIES SHALL BE FIELD VERIFIED BY THE CONTRACTOR PRIOR TO CONSTRUCTION.

SEE DRAINAGE AREA MAP SHEETS FOR DRAINAGE SYMBOLOLOGY.

R/W & U/E PURCHASED UNDER JP 09032(05)

POB & ASSOCIATES, OKLAHOMA CITY, OK.
90% PLAN SUBMITTAL
 3/4/2024

AREA
 CUT FILL

VOLUME
 CUT FILL

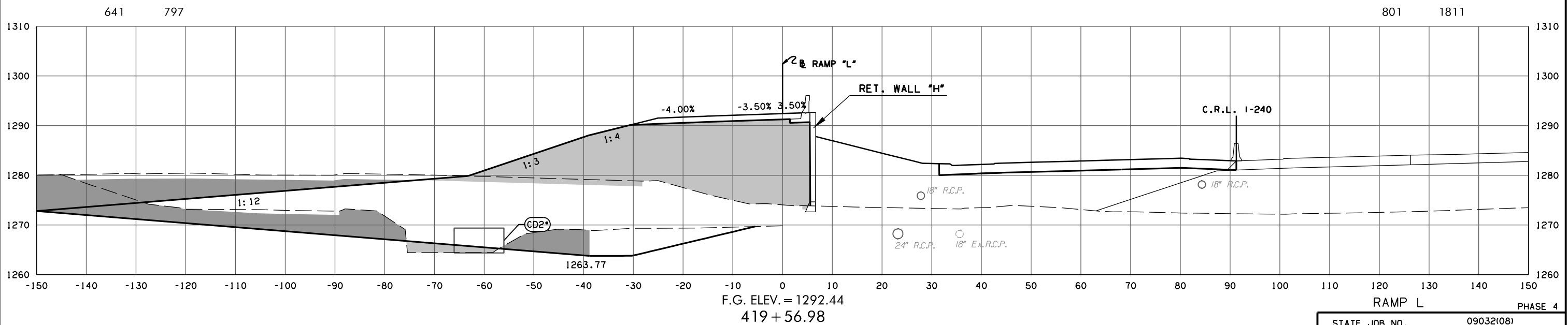
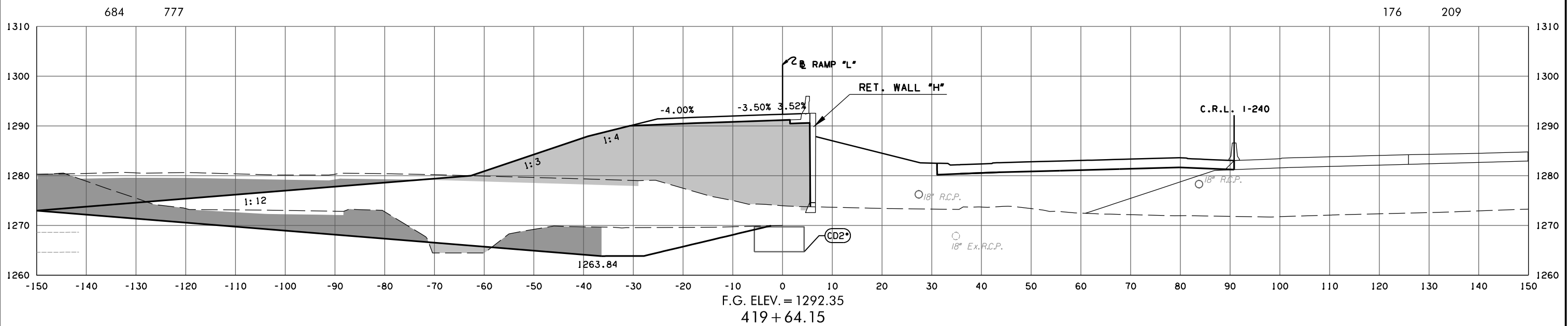

3/4/2024 3:59:33 PM H:\PROJECTS\2789_CrossRoads_Phase 4\Roadway\Drawings\Sections\0903208-XSEC_Ramp-L.dgn

(CAUTION) THE LOCATION OF ALL UTILITIES AS SHOWN ARE APPROXIMATE. DUE TO RELOCATION'S PLANNED OR PRESENTLY UNDER CONSTRUCTION THERE ARE SOME UTILITIES THAT WILL BE RELOCATED AND NOT SHOWN ON THESE PLANS. THE CONTRACTOR SHALL BE RESPONSIBLE FOR ANY DAMAGE TO ALL UTILITIES.
 DEPTH & LOCATION OF EXISTING UTILITIES SHALL BE FIELD VERIFIED BY THE CONTRACTOR PRIOR TO CONSTRUCTION.

SEE DRAINAGE AREA MAP SHEETS FOR DRAINAGE SYMBOLOLOGY.

R/W & U/E PURCHASED UNDER JP 09032(05)

POB & ASSOCIATES, OKLAHOMA CITY, OK.
90% PLAN SUBMITTAL
 3/4/2024

AREA
 CUT FILL

VOLUME
 CUT FILL

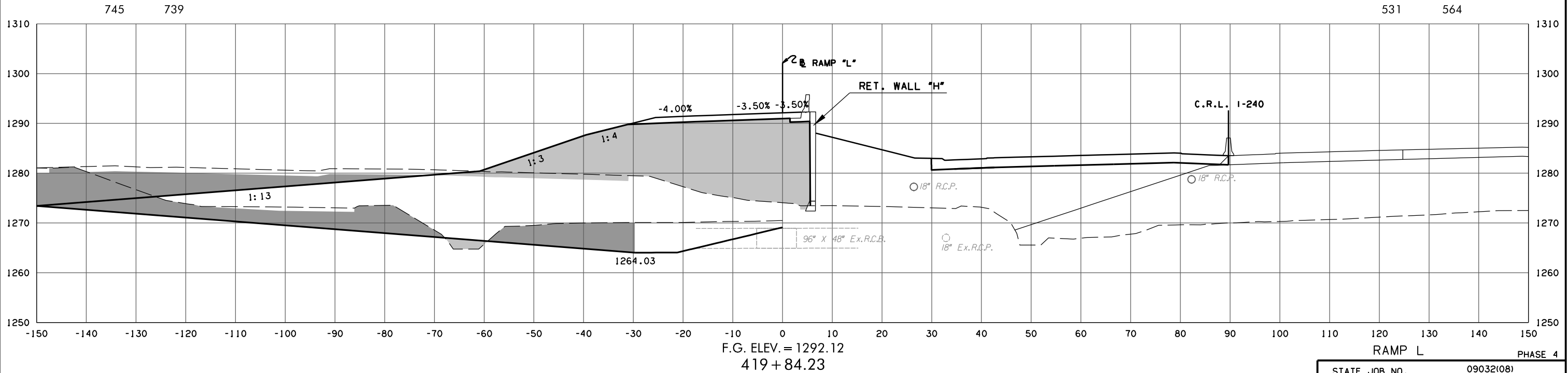
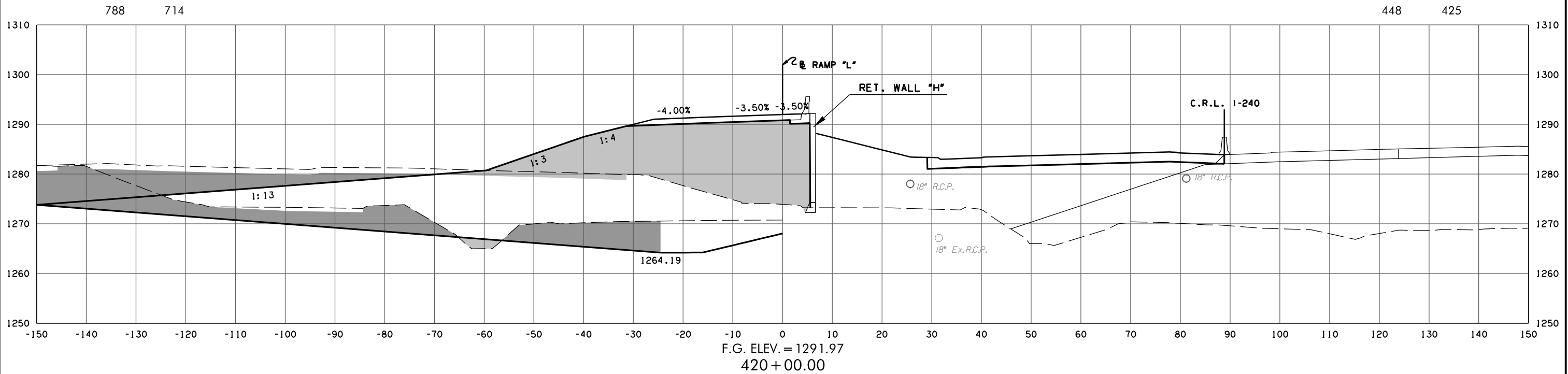

3/4/2024 3:59:33 PM H:\PROJECTS\2789_CrossRoads_Phase 4\Roadway\Drawings\Sections\0903208-XSEC_Ramp_L.dgn

STATE JOB NO. 09032(08)
 OKLAHOMA COUNTY SHEET NO. X261

(CAUTION) THE LOCATION OF ALL UTILITIES AS SHOWN ARE APPROXIMATE. DUE TO RELOCATION'S PLANNED OR PRESENTLY UNDER CONSTRUCTION THERE ARE SOME UTILITIES THAT WILL BE RELOCATED AND NOT SHOWN ON THESE PLANS. THE CONTRACTOR SHALL BE RESPONSIBLE FOR ANY DAMAGE TO ALL UTILITIES.
 DEPTH & LOCATION OF EXISTING UTILITIES SHALL BE FIELD VERIFIED BY THE CONTRACTOR PRIOR TO CONSTRUCTION.

SEE DRAINAGE AREA MAP SHEETS FOR DRAINAGE SYMBOLOLOGY.

R/W & U/E PURCHASED UNDER JP 09032(105)

POB & ASSOCIATES, OKLAHOMA CITY, OK.
90% PLAN SUBMITTAL
 3/4/2024

AREA
 CUT FILL

VOLUME
 CUT FILL

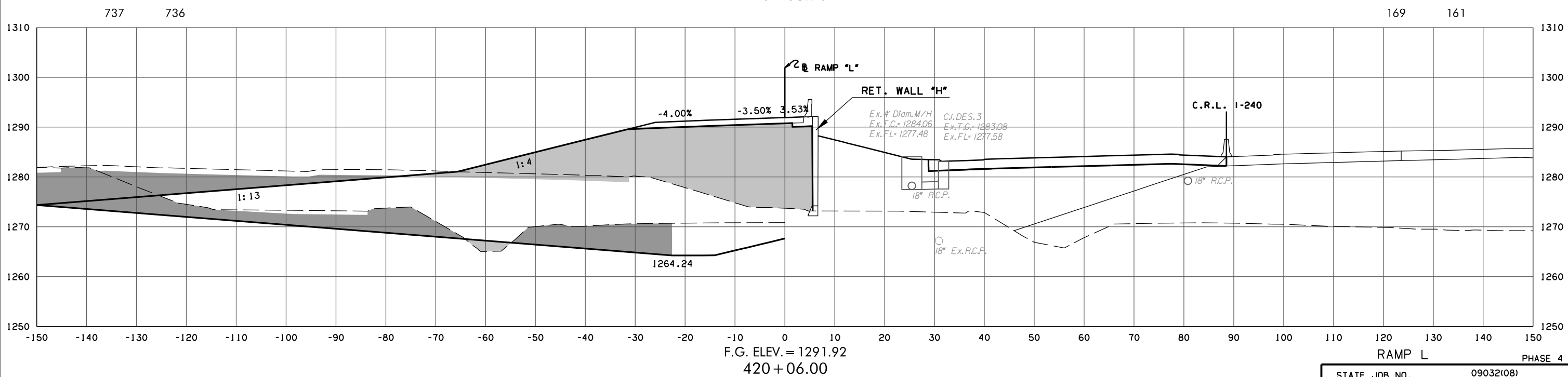
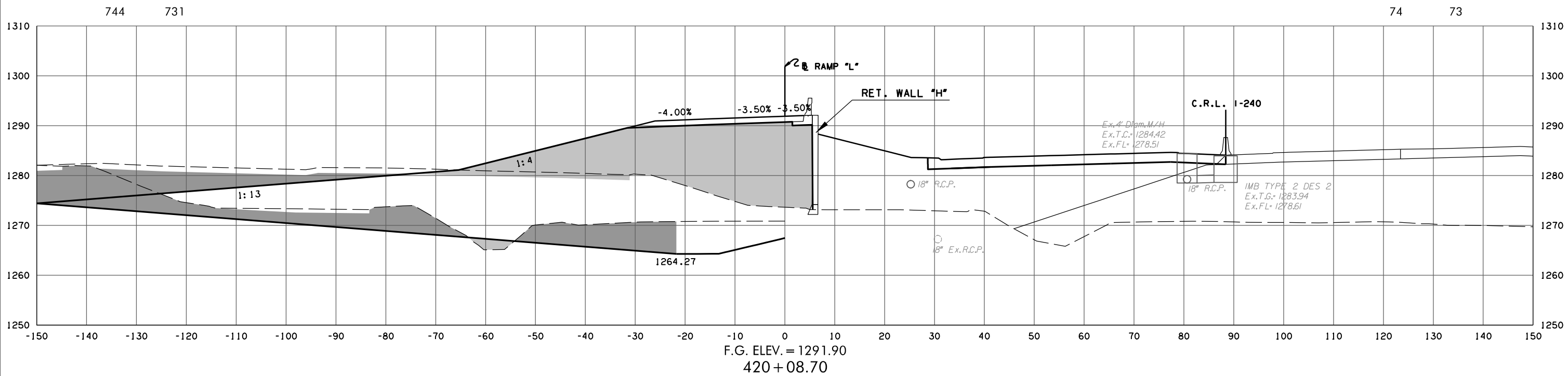

3/4/2024 3:59:34 PM H:\PROJECTS\2789_CrossRoads_Phase 4\Roadway\Drawings\Sections\0903208-XSEC_Ramp_L.dgn

RAMP L PHASE 4
 STATE JOB NO. 09032(108)
 OKLAHOMA COUNTY SHEET NO. X262

(CAUTION) THE LOCATION OF ALL UTILITIES AS SHOWN ARE APPROXIMATE. DUE TO RELOCATION'S PLANNED OR PRESENTLY UNDER CONSTRUCTION THERE ARE SOME UTILITIES THAT WILL BE RELOCATED AND NOT SHOWN ON THESE PLANS. THE CONTRACTOR SHALL BE RESPONSIBLE FOR ANY DAMAGE TO ALL UTILITIES.

SEE DRAINAGE AREA MAP SHEETS FOR DRAINAGE SYMBOLOLOGY.

R/W & U/E PURCHASED UNDER JP 09032(05)

POB & ASSOCIATES, OKLAHOMA CITY, OK.

**90% PLAN
SUBMITTAL**

3/4/2024

DEPTH & LOCATION OF EXISTING UTILITIES SHALL BE FIELD VERIFIED BY THE CONTRACTOR PRIOR TO CONSTRUCTION.

AREA
CUT FILL

VOLUME
CUT FILL

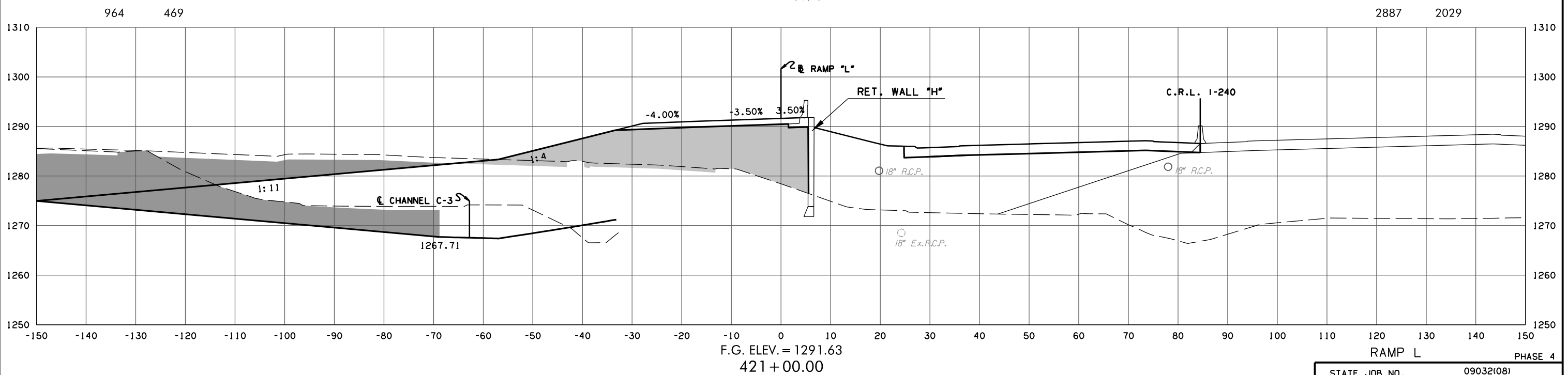
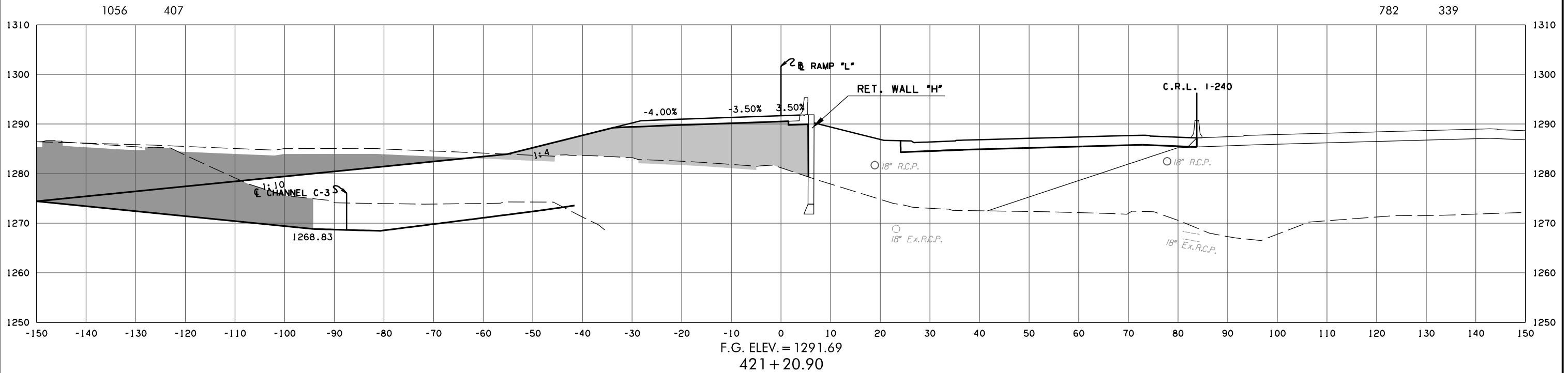

RAMP L PHASE 4

STATE JOB NO. 09032(08)
OKLAHOMA COUNTY SHEET NO. X263

3/4/2024 3:59:35 PM H:\PROJECTS\2789_CrossRoads_Phase 4\Roadway\Drawings\Sections\0903208-XSEC_Ramp-L.dgn

(CAUTION) THE LOCATION OF ALL UTILITIES AS SHOWN ARE APPROXIMATE. DUE TO RELOCATION'S PLANNED OR PRESENTLY UNDER CONSTRUCTION THERE ARE SOME UTILITIES THAT WILL BE RELOCATED AND NOT SHOWN ON THESE PLANS. THE CONTRACTOR SHALL BE RESPONSIBLE FOR ANY DAMAGE TO ALL UTILITIES.
 DEPTH & LOCATION OF EXISTING UTILITIES SHALL BE FIELD VERIFIED BY THE CONTRACTOR PRIOR TO CONSTRUCTION.

SEE DRAINAGE AREA MAP SHEETS FOR DRAINAGE SYMBOLOLOGY.

R/W & U/E PURCHASED UNDER JP 09032(05)

POB & ASSOCIATES, OKLAHOMA CITY, OK.

**90% PLAN
 SUBMITTAL**

3/4/2024

AREA
 CUT FILL

VOLUME
 CUT FILL

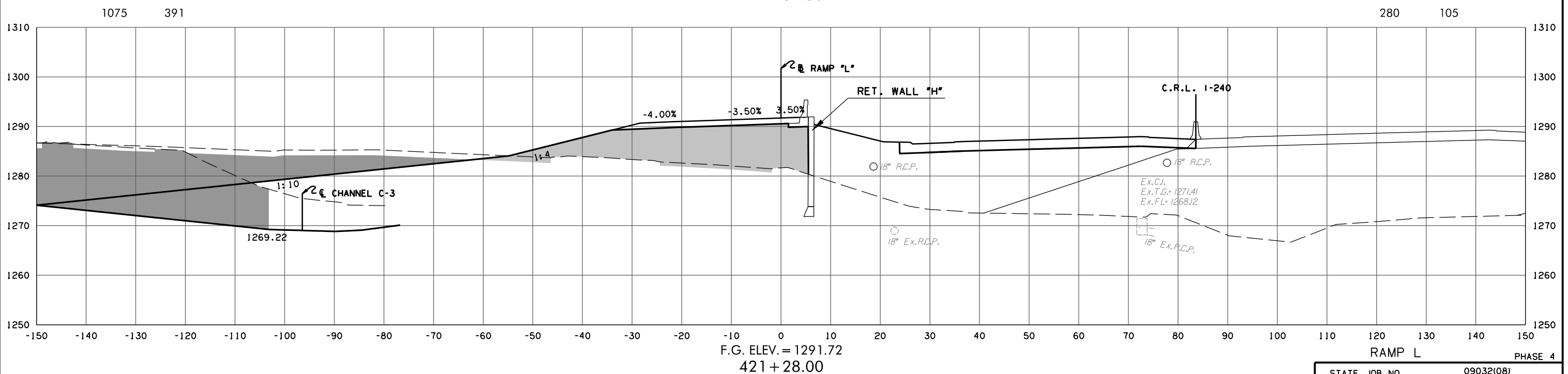
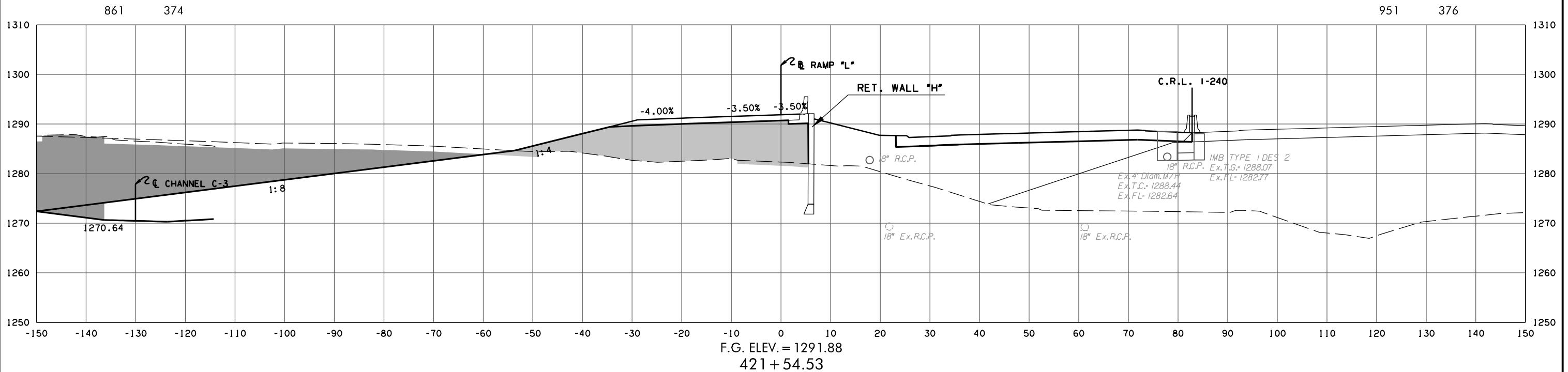

3/4/2024 3:59:36 PM H:\PROJECTS\2789_CrossRoads_Phase 4\Roadway\Drawings\Sections\0903208-XSEC_Ramp-L.dgn

STATE JOB NO. 09032(08)
 OKLAHOMA COUNTY SHEET NO. X264

(CAUTION) THE LOCATION OF ALL UTILITIES AS SHOWN ARE APPROXIMATE. DUE TO RELOCATION'S PLANNED OR PRESENTLY UNDER CONSTRUCTION THERE ARE SOME UTILITIES THAT WILL BE RELOCATED AND NOT SHOWN ON THESE PLANS. THE CONTRACTOR SHALL BE RESPONSIBLE FOR ANY DAMAGE TO ALL UTILITIES.
 DEPTH & LOCATION OF EXISTING UTILITIES SHALL BE FIELD VERIFIED BY THE CONTRACTOR PRIOR TO CONSTRUCTION.

SEE DRAINAGE AREA MAP SHEETS FOR DRAINAGE SYMBOLOLOGY.

R/W & U/E PURCHASED UNDER JP 09032(05)

POB & ASSOCIATES, OKLAHOMA CITY, OK.
90% PLAN SUBMITTAL
 3/4/2024

AREA
 CUT FILL

VOLUME
 CUT FILL

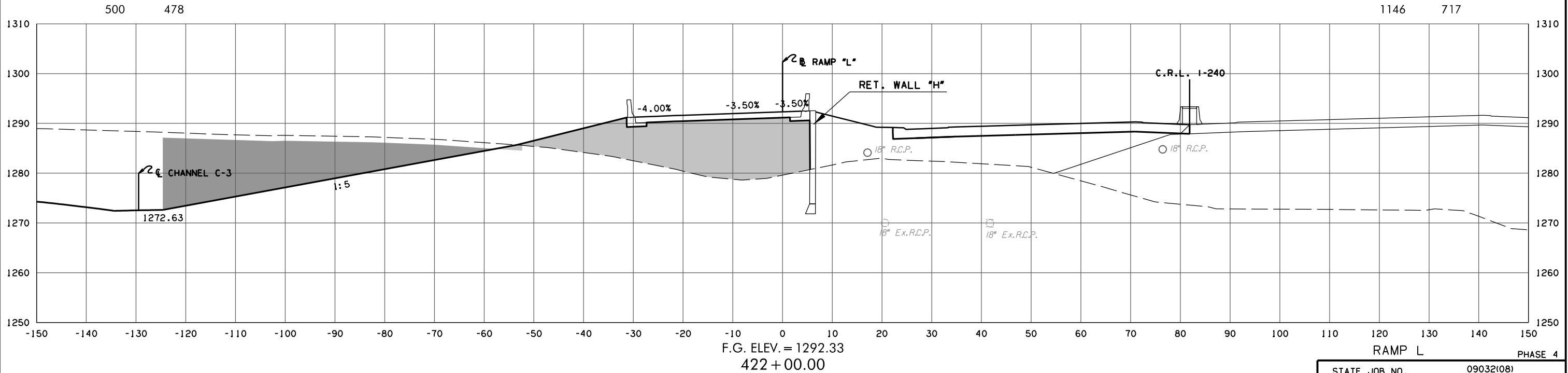
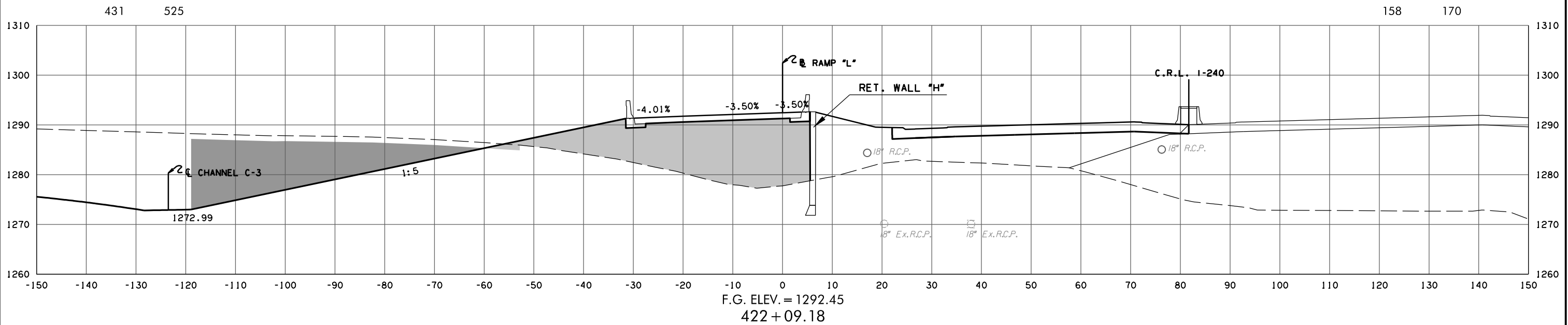

3/4/2024 3:59:37 PM H:\PROJECTS\2789_CrossRoads_Phase 4\Roadway\Drawings\Sections\0903208-XSEC_Ramp_L.dgn

STATE JOB NO. 09032(08)
 OKLAHOMA COUNTY SHEET NO. X265

(CAUTION) THE LOCATION OF ALL UTILITIES AS SHOWN ARE APPROXIMATE. DUE TO RELOCATION'S PLANNED OR PRESENTLY UNDER CONSTRUCTION THERE ARE SOME UTILITIES THAT WILL BE RELOCATED AND NOT SHOWN ON THESE PLANS. THE CONTRACTOR SHALL BE RESPONSIBLE FOR ANY DAMAGE TO ALL UTILITIES.
 DEPTH & LOCATION OF EXISTING UTILITIES SHALL BE FIELD VERIFIED BY THE CONTRACTOR PRIOR TO CONSTRUCTION.

SEE DRAINAGE AREA MAP SHEETS FOR DRAINAGE SYMBOLOLOGY.

R/W & U/E PURCHASED UNDER JP 09032(05)

POB & ASSOCIATES, OKLAHOMA CITY, OK.
90% PLAN SUBMITTAL
 3/4/2024

AREA
 CUT FILL

VOLUME
 CUT FILL

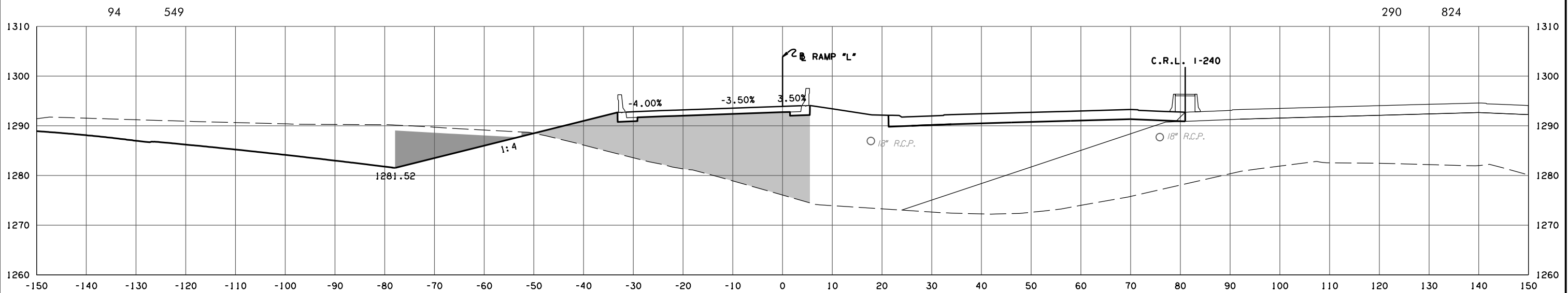

F.G. ELEV. = 1293.90
 422+92.17
 END FULL SUPER ROTATION

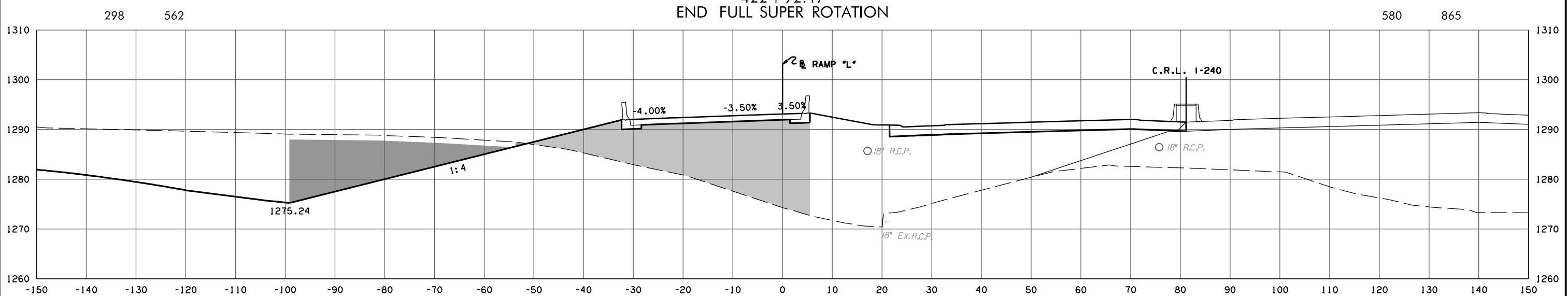

F.G. ELEV. = 1293.11
 422+52.13

STATE JOB NO. 09032(08)
 OKLAHOMA COUNTY SHEET NO. X266

3/4/2024 3:59:37 PM H:\PROJECTS\2789_CrossRoads_Phase 4\Roadway\Drawings\Sections\0903208-XSEC_Ramp_L.dgn

(CAUTION) THE LOCATION OF ALL UTILITIES AS SHOWN ARE APPROXIMATE. DUE TO RELOCATION'S PLANNED OR PRESENTLY UNDER CONSTRUCTION THERE ARE SOME UTILITIES THAT WILL BE RELOCATED AND NOT SHOWN ON THESE PLANS. THE CONTRACTOR SHALL BE RESPONSIBLE FOR ANY DAMAGE TO ALL UTILITIES.
 DEPTH & LOCATION OF EXISTING UTILITIES SHALL BE FIELD VERIFIED BY THE CONTRACTOR PRIOR TO CONSTRUCTION.

SEE DRAINAGE AREA MAP SHEETS FOR DRAINAGE SYMBOLOLOGY.

R/W & U/E PURCHASED UNDER JP 09032(05)

POB & ASSOCIATES, OKLAHOMA CITY, OK.
90% PLAN SUBMITTAL
 3/4/2024

AREA
 CUT FILL

VOLUME
 CUT FILL

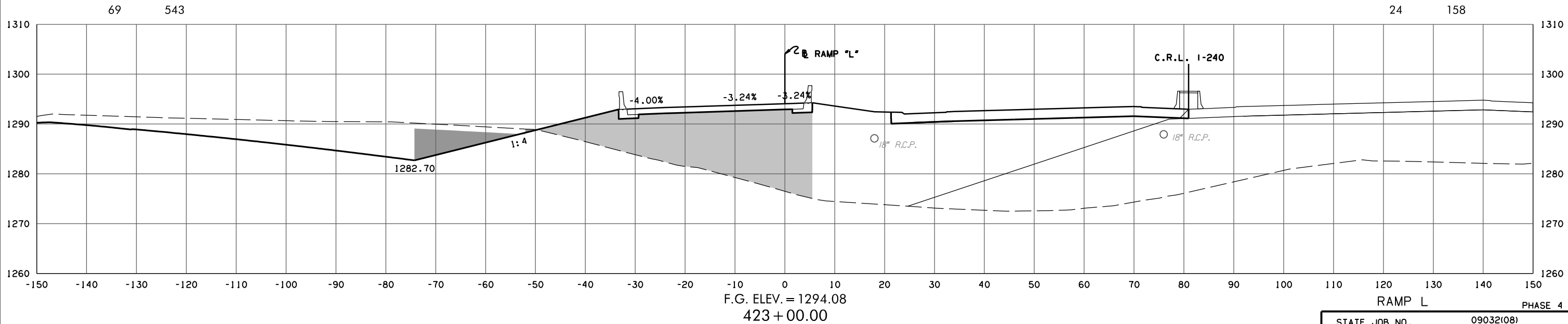
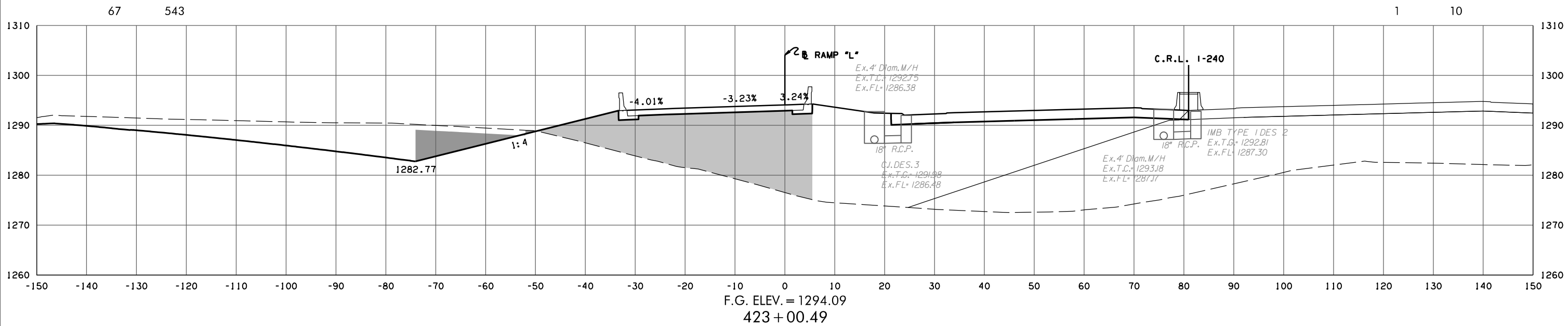

3/4/2024 3:59:38 PM H:\PROJECTS\2789_CrossRoads_Phase 4\Roadway\Drawings\Sections\0903208-XSEC_Ramp_L.dgn

STATE JOB NO. 09032(08)
 OKLAHOMA COUNTY SHEET NO. X267

(CAUTION) THE LOCATION OF ALL UTILITIES AS SHOWN ARE APPROXIMATE. DUE TO RELOCATION'S PLANNED OR PRESENTLY UNDER CONSTRUCTION THERE ARE SOME UTILITIES THAT WILL BE RELOCATED AND NOT SHOWN ON THESE PLANS. THE CONTRACTOR SHALL BE RESPONSIBLE FOR ANY DAMAGE TO ALL UTILITIES.
 DEPTH & LOCATION OF EXISTING UTILITIES SHALL BE FIELD VERIFIED BY THE CONTRACTOR PRIOR TO CONSTRUCTION.

SEE DRAINAGE AREA MAP SHEETS FOR DRAINAGE SYMBOLOLOGY.

R/W & U/E PURCHASED UNDER JP 09032(05)

POB & ASSOCIATES, OKLAHOMA CITY, OK.
90% PLAN SUBMITTAL
 3/4/2024

AREA
 CUT FILL

VOLUME
 CUT FILL

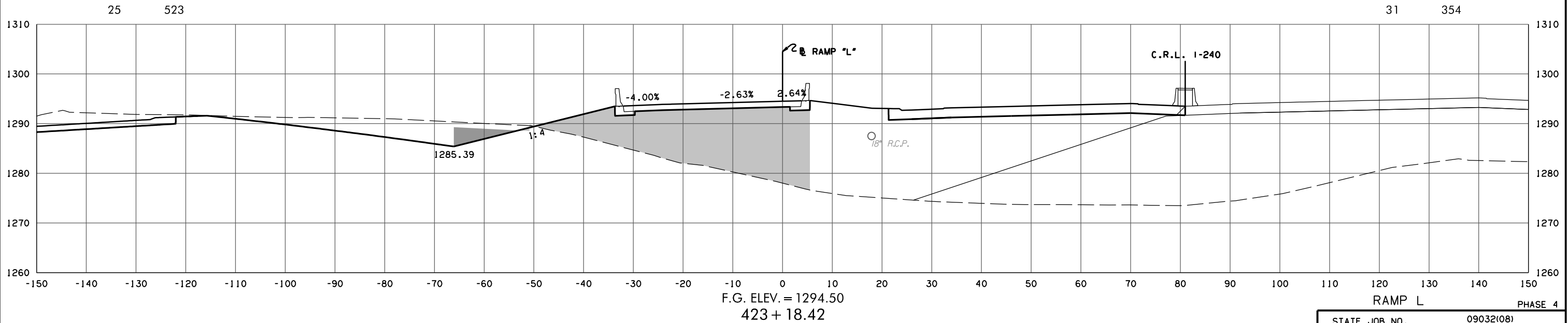
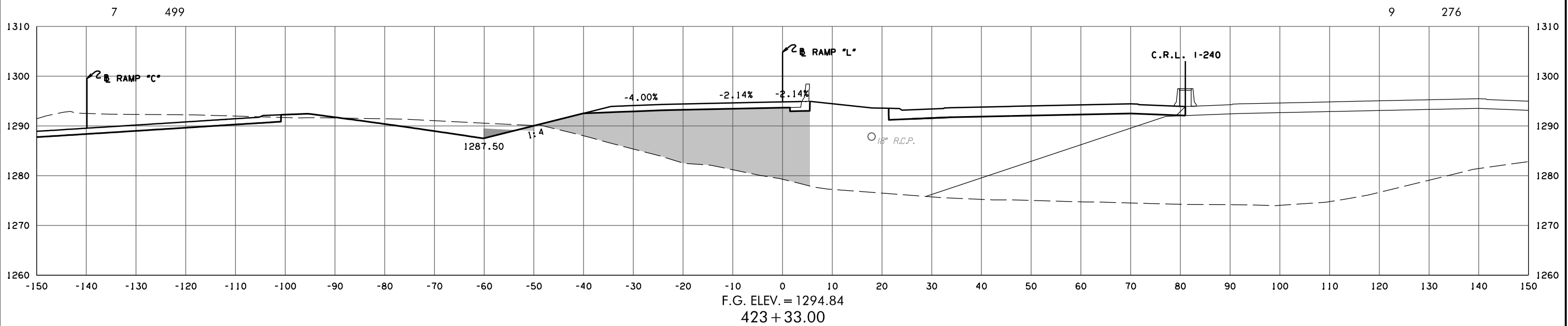

3/4/2024 3:59:39 PM H:\PROJECTS\2789_CrossRoads_Phase 4\Roadway\Drawings\Sections\0903208-XSEC_Ramp_L.dgn

STATE JOB NO. 09032(08)
 OKLAHOMA COUNTY SHEET NO. X268

(CAUTION) THE LOCATION OF ALL UTILITIES AS SHOWN ARE APPROXIMATE. DUE TO RELOCATION'S PLANNED OR PRESENTLY UNDER CONSTRUCTION THERE ARE SOME UTILITIES THAT WILL BE RELOCATED AND NOT SHOWN ON THESE PLANS. THE CONTRACTOR SHALL BE RESPONSIBLE FOR ANY DAMAGE TO ALL UTILITIES.
 DEPTH & LOCATION OF EXISTING UTILITIES SHALL BE FIELD VERIFIED BY THE CONTRACTOR PRIOR TO CONSTRUCTION.

SEE DRAINAGE AREA MAP SHEETS FOR DRAINAGE SYMBOLOLOGY.

R/W & U/E PURCHASED UNDER JP 09032(05)

POB & ASSOCIATES, OKLAHOMA CITY, OK.
90% PLAN SUBMITTAL
 3/4/2024

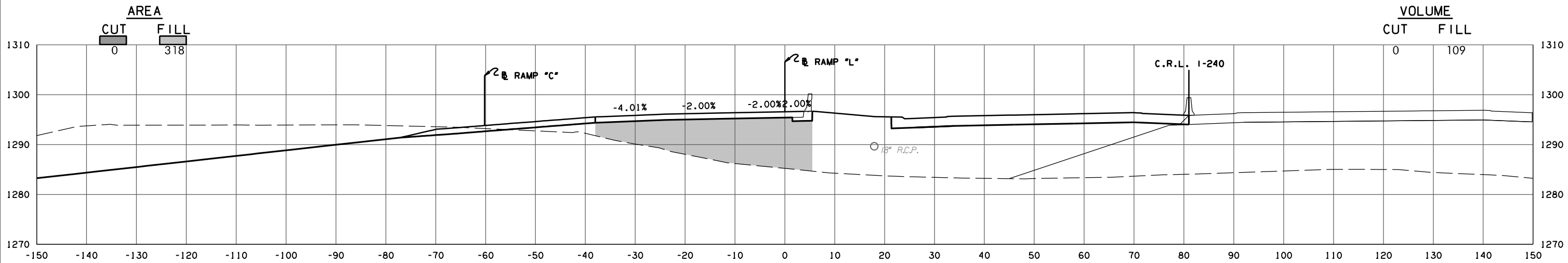

F.G. ELEV. = 1296.58
 424 + 08.81
 BEGIN SUPER ROTATION

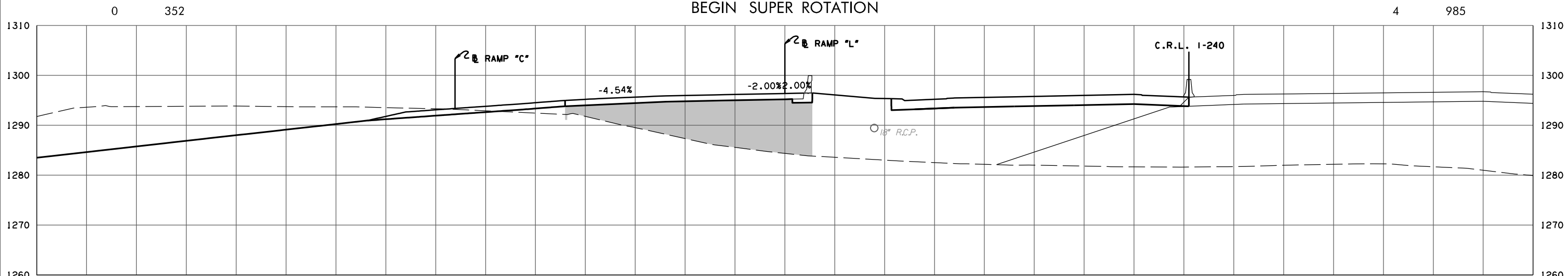

F.G. ELEV. = 1296.38
 424 + 00.00

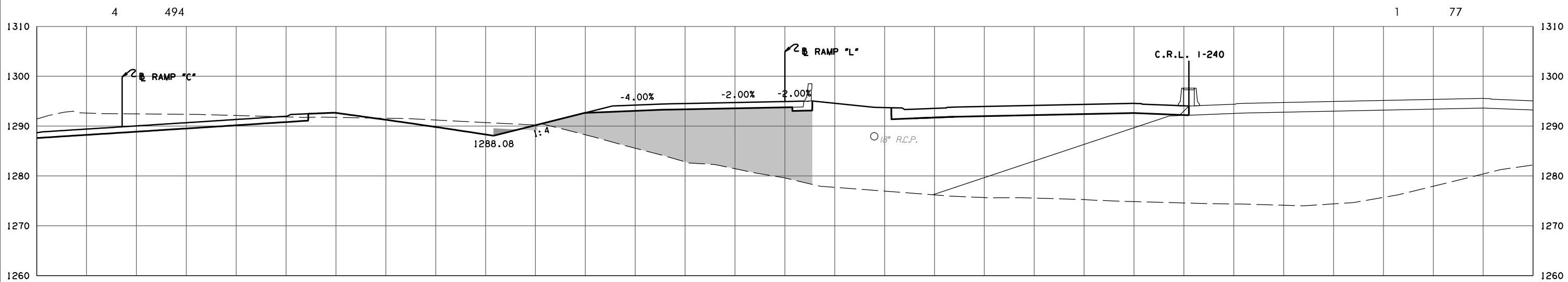

F.G. ELEV. = 1294.93
 423 + 37.17
 END SUPER ROTATION

RAMP L PHASE 4
 STATE JOB NO. 09032(08)
 OKLAHOMA COUNTY SHEET NO. X269

3/4/2024 3:59:40 PM
 H:\PROJECTS\2789_CrossRoads_Phase 4\Roadway\Drawings\Sections\0903208-XSEC_Ramp_L.dgn

(CAUTION) THE LOCATION OF ALL UTILITIES AS SHOWN ARE APPROXIMATE. DUE TO RELOCATION'S PLANNED OR PRESENTLY UNDER CONSTRUCTION THERE ARE SOME UTILITIES THAT WILL BE RELOCATED AND NOT SHOWN ON THESE PLANS. THE CONTRACTOR SHALL BE RESPONSIBLE FOR ANY DAMAGE TO ALL UTILITIES.
 DEPTH & LOCATION OF EXISTING UTILITIES SHALL BE FIELD VERIFIED BY THE CONTRACTOR PRIOR TO CONSTRUCTION.

SEE DRAINAGE AREA MAP SHEETS FOR DRAINAGE SYMBOLOLOGY.

R/W & U/E PURCHASED UNDER JP 09032(05)

POB & ASSOCIATES, OKLAHOMA CITY, OK.
90% PLAN SUBMITTAL
 3/4/2024

AREA
 CUT FILL

VOLUME
 CUT FILL

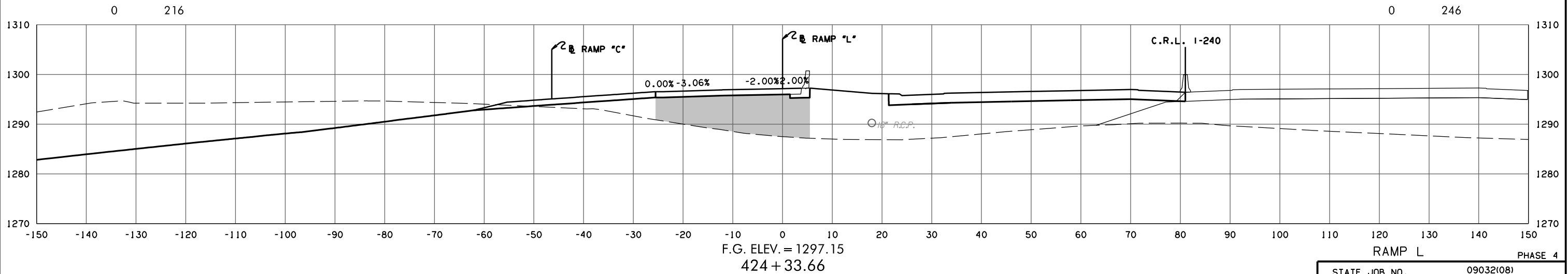
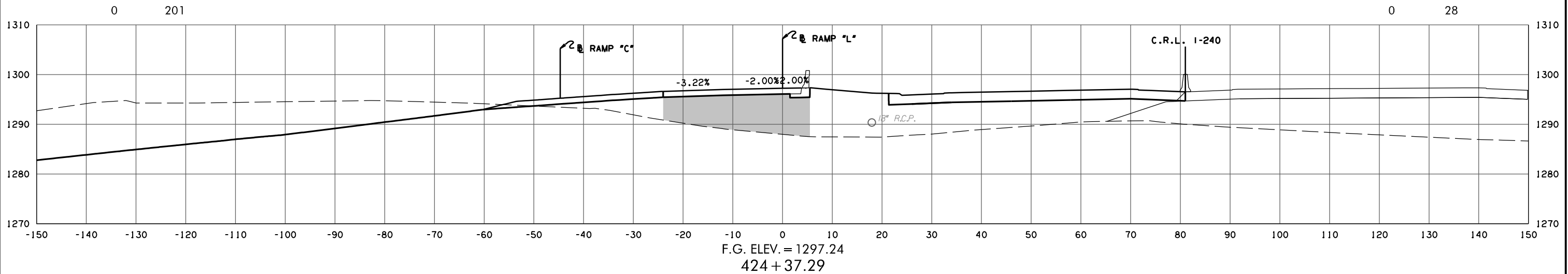
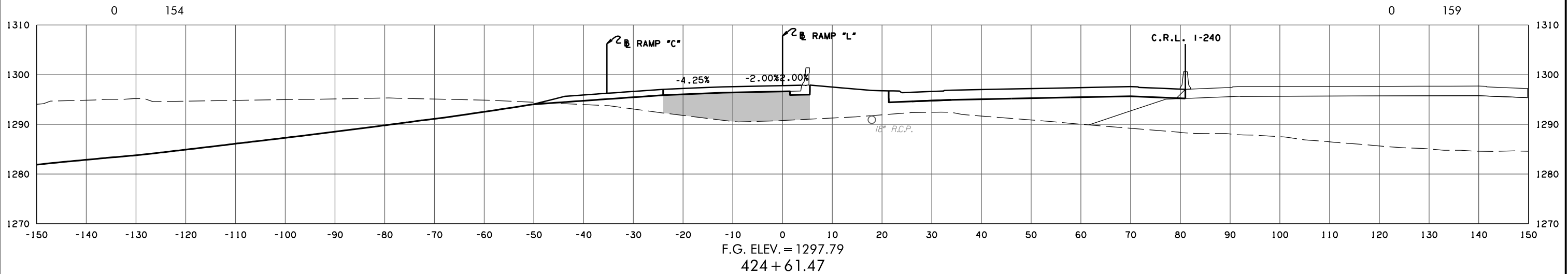

3/4/2024 3:59:41 PM H:\PROJECTS\2789_CrossRoads_Phase 4\Roadway\Drawings\Sections\0903208-XSEC_Ramp_L.dgn

RAMP L PHASE 4
 STATE JOB NO. 09032(08)
 OKLAHOMA COUNTY SHEET NO. X270

(CAUTION) THE LOCATION OF ALL UTILITIES AS SHOWN ARE APPROXIMATE. DUE TO RELOCATION'S PLANNED OR PRESENTLY UNDER CONSTRUCTION THERE ARE SOME UTILITIES THAT WILL BE RELOCATED AND NOT SHOWN ON THESE PLANS. THE CONTRACTOR SHALL BE RESPONSIBLE FOR ANY DAMAGE TO ALL UTILITIES.

DEPTH & LOCATION OF EXISTING UTILITIES SHALL BE FIELD VERIFIED BY THE CONTRACTOR PRIOR TO CONSTRUCTION.

SEE DRAINAGE AREA MAP SHEETS FOR DRAINAGE SYMBOLOLOGY.

R/W & U/E PURCHASED UNDER JP 09032(05)

POB & ASSOCIATES, OKLAHOMA CITY, OK.

**90% PLAN
SUBMITTAL**

3/4/2024

AREA
CUT FILL

VOLUME
CUT FILL

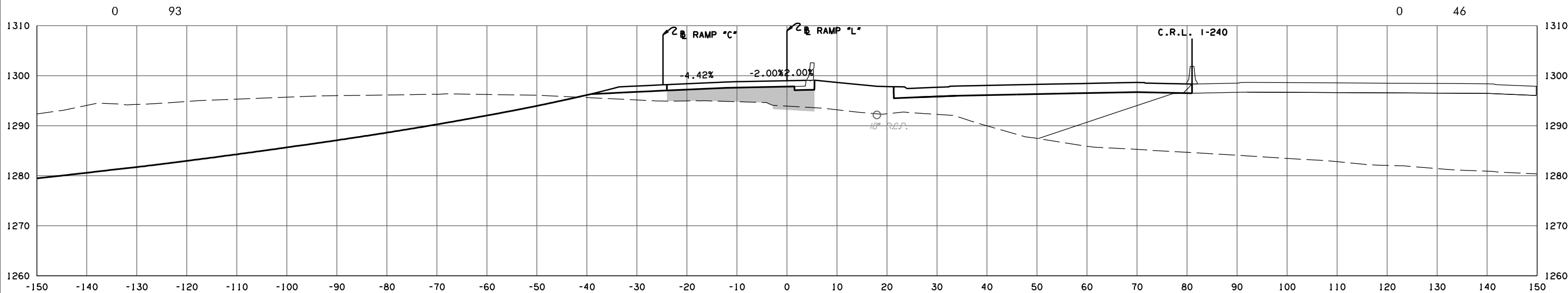

F.G. ELEV. = 1298.99
425 + 13.58

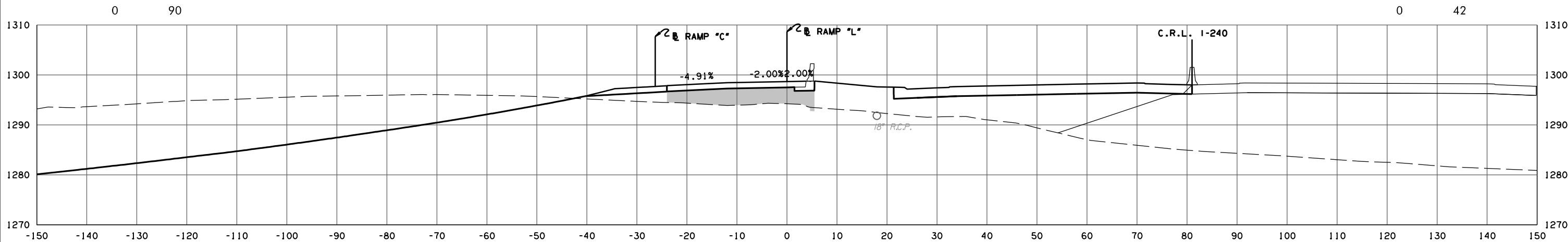

F.G. ELEV. = 1298.68
425 + 00.00

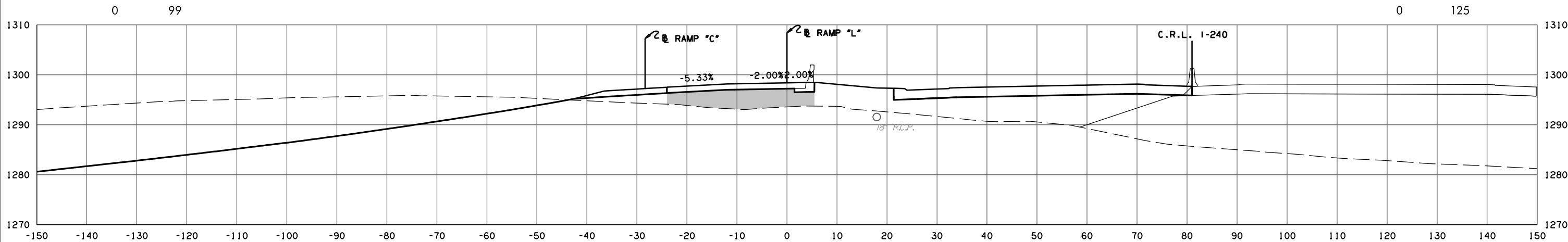

F.G. ELEV. = 1298.40
424 + 88.07
FULL SUPER ROTATION

RAMP L PHASE 4

STATE JOB NO. 09032(08)
OKLAHOMA COUNTY SHEET NO. X271

3/4/2024 3:59:41 PM H:\PROJECTS\2789_CrossRoads_Phase 4\Roadway\Drawings\Sections\0903208-XSEC_Ramp_L.dgn

(CAUTION) THE LOCATION OF ALL UTILITIES AS SHOWN ARE APPROXIMATE. DUE TO RELOCATION'S PLANNED OR PRESENTLY UNDER CONSTRUCTION THERE ARE SOME UTILITIES THAT WILL BE RELOCATED AND NOT SHOWN ON THESE PLANS. THE CONTRACTOR SHALL BE RESPONSIBLE FOR ANY DAMAGE TO ALL UTILITIES. DEPTH & LOCATION OF EXISTING UTILITIES SHALL BE FIELD VERIFIED BY THE CONTRACTOR PRIOR TO CONSTRUCTION.

SEE DRAINAGE AREA MAP SHEETS FOR DRAINAGE SYMBOLOLOGY.

R/W & U/E PURCHASED UNDER JP 09032(05)

POB & ASSOCIATES, OKLAHOMA CITY, OK.
90% PLAN
SUBMITTAL
 3/4/2024

AREA
 CUT FILL

VOLUME
 CUT FILL

3/4/2024 3:59:42 PM H:\PROJECTS\2785_CrossRoads_Phase 4\Roadway\Drawings\Sections\0903208-XSEC_Ramp-L.dgn

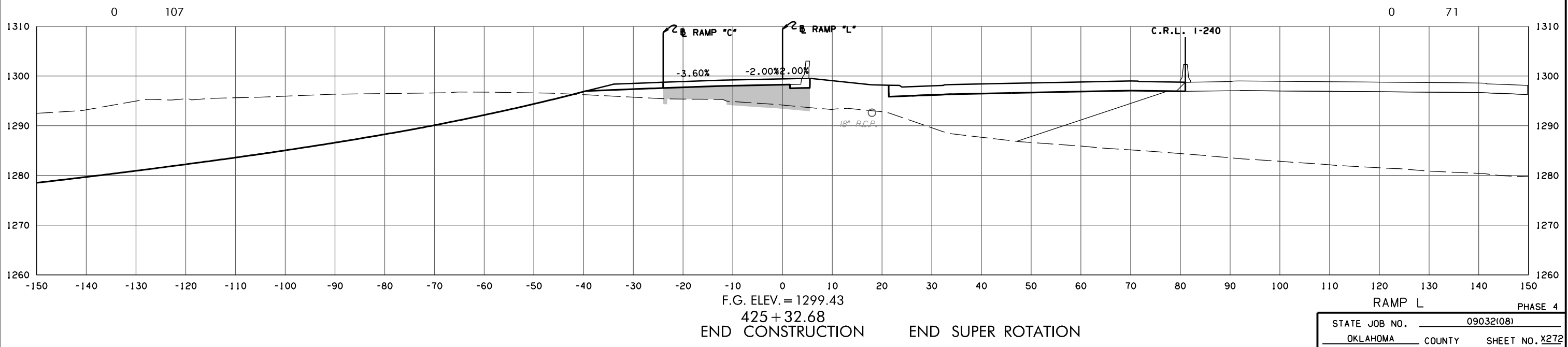

F.G. ELEV. = 1299.43
 425 + 32.68
 END CONSTRUCTION END SUPER ROTATION

STATE JOB NO. 09032(08)
 OKLAHOMA COUNTY SHEET NO. X272

(CAUTION) THE LOCATION OF ALL UTILITIES AS SHOWN ARE APPROXIMATE. DUE TO RELOCATION'S PLANNED OR PRESENTLY UNDER CONSTRUCTION THERE ARE SOME UTILITIES THAT WILL BE RELOCATED AND NOT SHOWN ON THESE PLANS. THE CONTRACTOR SHALL BE RESPONSIBLE FOR ANY DAMAGE TO ALL UTILITIES.

DEPTH & LOCATION OF EXISTING UTILITIES SHALL BE FIELD VERIFIED BY THE CONTRACTOR PRIOR TO CONSTRUCTION.

SEE DRAINAGE AREA MAP SHEETS FOR DRAINAGE SYMBOLOLOGY.

R/W & U/E PURCHASED UNDER JP 09032(05)

POB & ASSOCIATES, OKLAHOMA CITY, OK.

**90% PLAN
SUBMITTAL**

3/4/2024

AREA
CUT FILL

VOLUME
CUT FILL

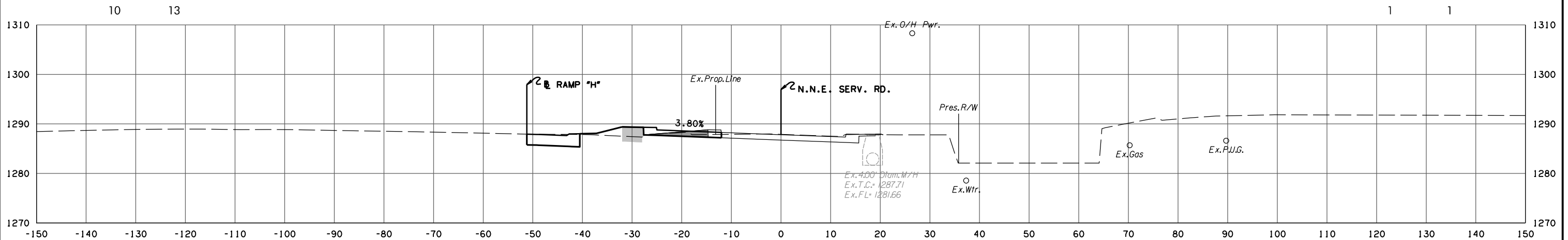

95+02.23

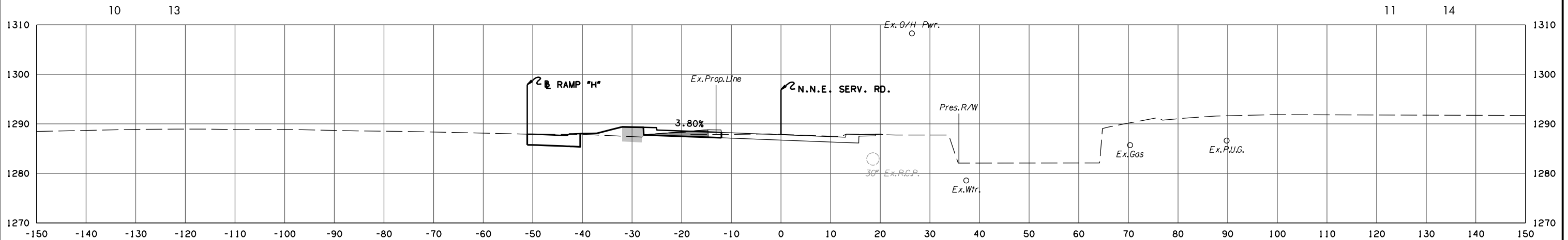

95+00.00

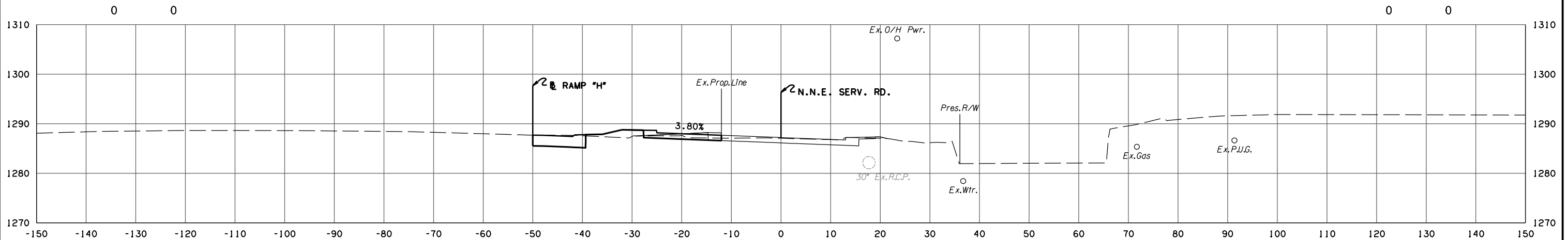

94+40.74

BEGIN FULL SUPER ROTATION BEGIN CONSTRUCTION

N.N.E. SERV. RD. PHASE 4

STATE JOB NO. 09032(08)
OKLAHOMA COUNTY SHEET NO. X273

3/4/2024 3:59:43 PM H:\PROJECTS\2789_CrossRoads_Phase 4\Roadway\Drawings\Sections\0903208-XSEC_NNE_SERV_RD.dgn

(CAUTION) THE LOCATION OF ALL UTILITIES AS SHOWN ARE APPROXIMATE. DUE TO RELOCATION'S PLANNED OR PRESENTLY UNDER CONSTRUCTION THERE ARE SOME UTILITIES THAT WILL BE RELOCATED AND NOT SHOWN ON THESE PLANS. THE CONTRACTOR SHALL BE RESPONSIBLE FOR ANY DAMAGE TO ALL UTILITIES.
 DEPTH & LOCATION OF EXISTING UTILITIES SHALL BE FIELD VERIFIED BY THE CONTRACTOR PRIOR TO CONSTRUCTION.

SEE DRAINAGE AREA MAP SHEETS FOR DRAINAGE SYMBOLOLOGY.

R/W & U/E PURCHASED UNDER JP 09032(05)

POB & ASSOCIATES, OKLAHOMA CITY, OK.
90% PLAN SUBMITTAL
 3/4/2024

AREA
 CUT FILL

VOLUME
 CUT FILL

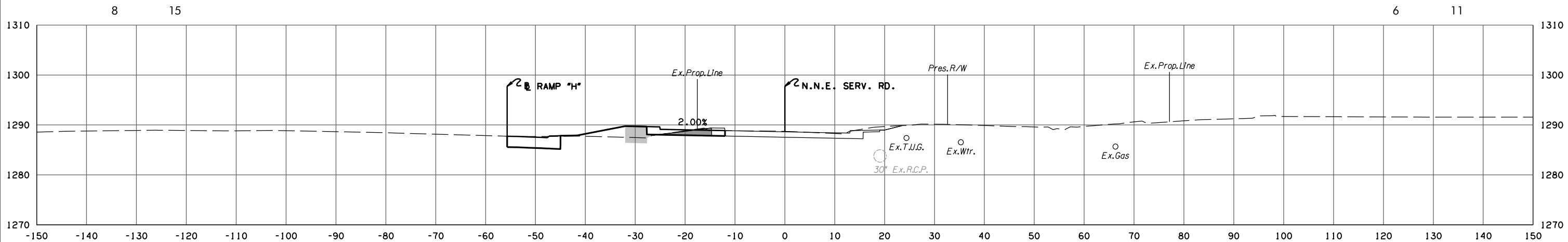

95+82.59
 REVERSE CROWN

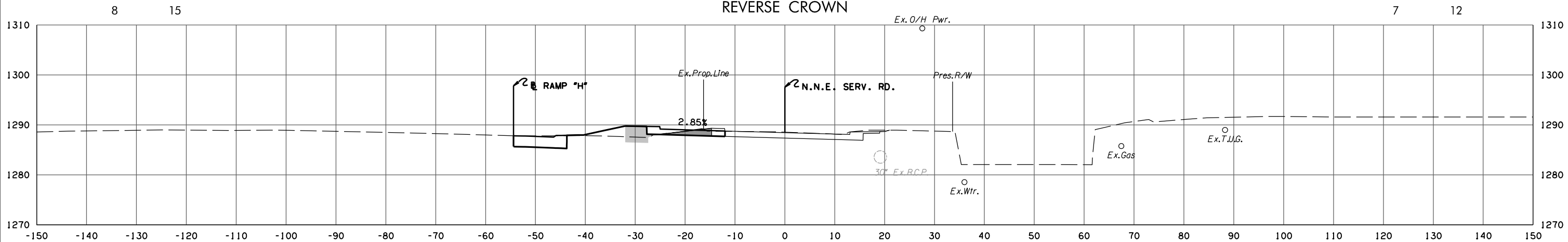

95+63.54

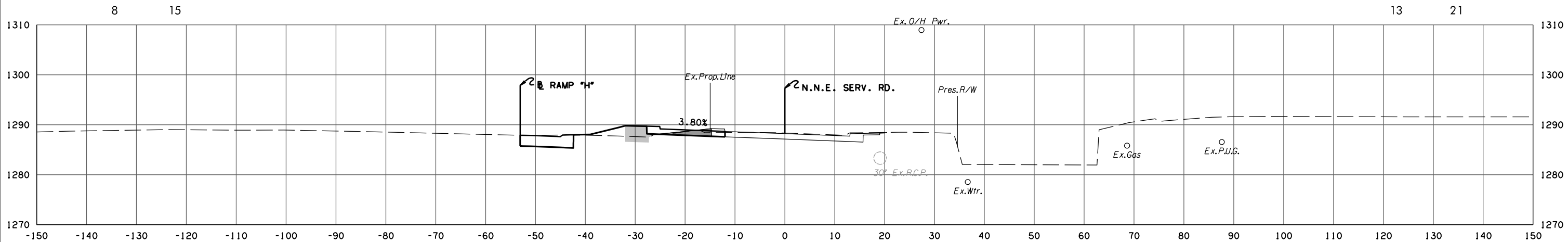

95+42.25
 END FULL SUPER ROTATION

N.N.E. SERV. RD. PHASE 4
 STATE JOB NO. 09032(08)
 OKLAHOMA COUNTY SHEET NO. X274

3/4/2024 3:59:44 PM
 H:\PROJECTS\2789_CrossRoads_Phase 4\Roadway\Drawings\Sections\0903208-XSEC_NNE_SERV_RD.dgn

(CAUTION) THE LOCATION OF ALL UTILITIES AS SHOWN ARE APPROXIMATE. DUE TO RELOCATION'S PLANNED OR PRESENTLY UNDER CONSTRUCTION THERE ARE SOME UTILITIES THAT WILL BE RELOCATED AND NOT SHOWN ON THESE PLANS. THE CONTRACTOR SHALL BE RESPONSIBLE FOR ANY DAMAGE TO ALL UTILITIES.

SEE DRAINAGE AREA MAP SHEETS FOR DRAINAGE SYMBOLOLOGY.

R/W & U/E PURCHASED UNDER JP 09032(05)

POE & ASSOCIATES, OKLAHOMA CITY, OK.

90% PLAN
SUBMITTAL

3/4/2024

AREA
CUT FILL

VOLUME
CUT FILL

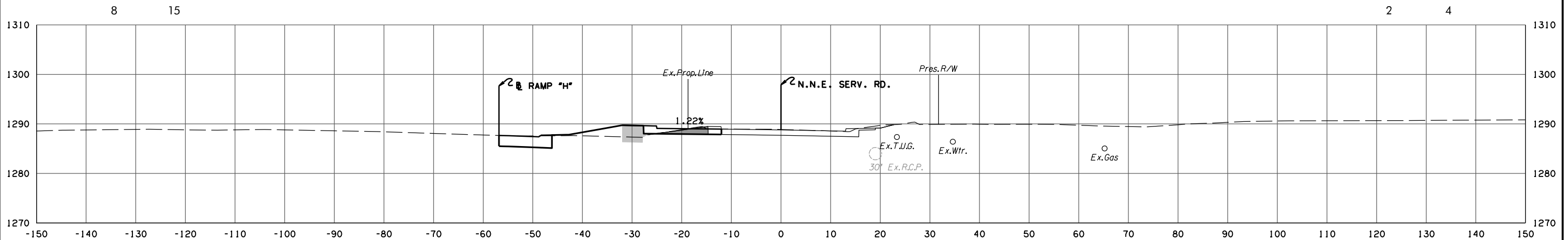

96+00.00

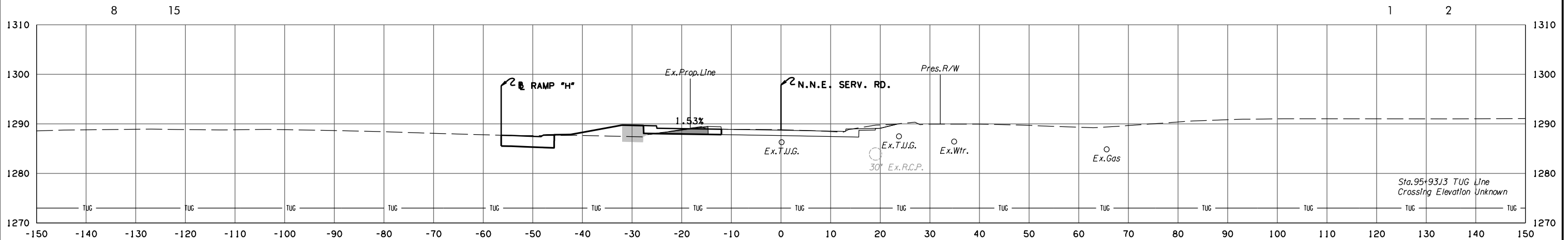

95+93.13

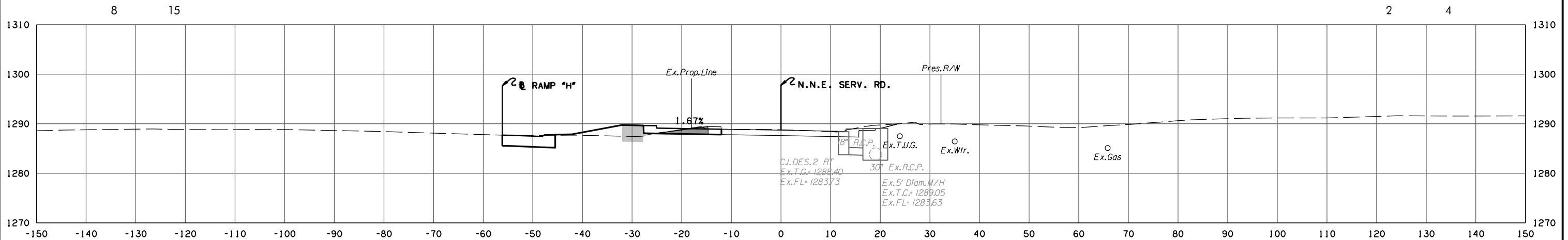

95+90.00

N.N.E. SERV. RD. PHASE 4

STATE JOB NO. 09032(08)
OKLAHOMA COUNTY SHEET NO. X275

3/4/2024 3:59:44 PM
H:\PROJECTS\2789_CrossRoads_Phase 4\Roadway\Drawings\Sections\0903208-XSEC-NNE SERV RD.dgn

(CAUTION) THE LOCATION OF ALL UTILITIES AS SHOWN ARE APPROXIMATE. DUE TO RELOCATION'S PLANNED OR PRESENTLY UNDER CONSTRUCTION THERE ARE SOME UTILITIES THAT WILL BE RELOCATED AND NOT SHOWN ON THESE PLANS. THE CONTRACTOR SHALL BE RESPONSIBLE FOR ANY DAMAGE TO ALL UTILITIES.
 DEPTH & LOCATION OF EXISTING UTILITIES SHALL BE FIELD VERIFIED BY THE CONTRACTOR PRIOR TO CONSTRUCTION.

SEE DRAINAGE AREA MAP SHEETS FOR DRAINAGE SYMBOLOLOGY.

R/W & U/E PURCHASED UNDER JP 09032(05)

POB & ASSOCIATES, OKLAHOMA CITY, OK.
90% PLAN SUBMITTAL
 3/4/2024

AREA
 CUT FILL

VOLUME
 CUT FILL

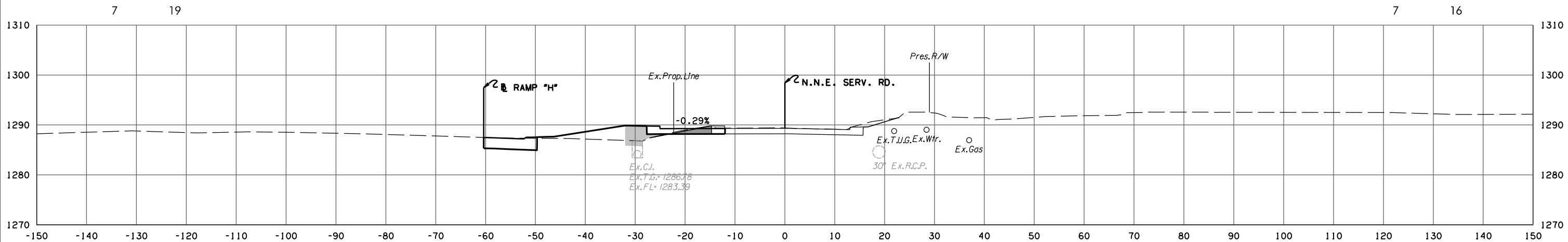

96+52.96

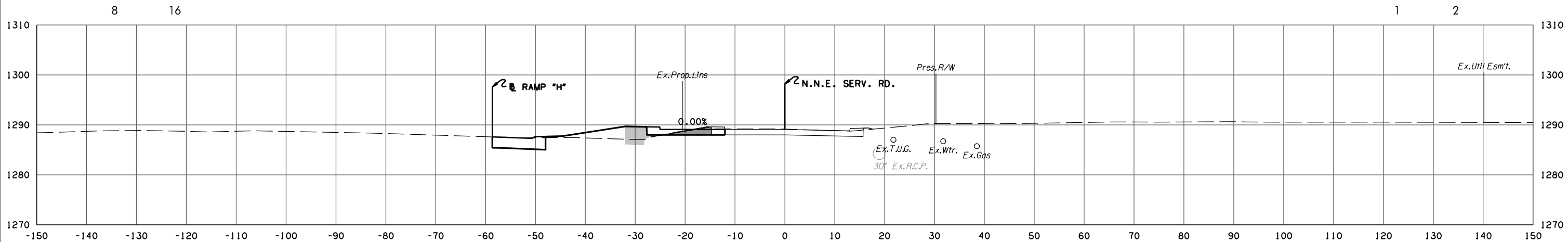

96+27.42
 FLAT

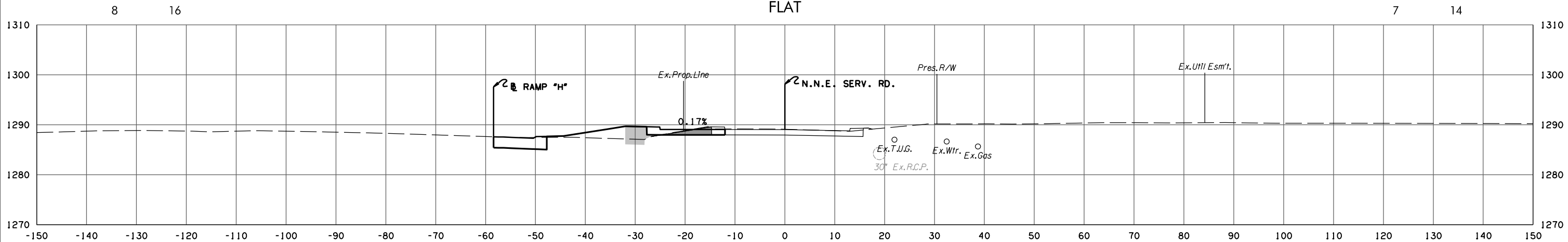

96+23.72

N.N.E. SERV. RD. PHASE 4
 STATE JOB NO. 09032(08)
 OKLAHOMA COUNTY SHEET NO. X276

3/4/2024 3:59:45 PM H:\PROJECTS\2789_CrossRoads_Phase 4\Roadway\Drawings\Sections\0903208-XSEC_NNE_SERV_RD.dgn

(CAUTION) THE LOCATION OF ALL UTILITIES AS SHOWN ARE APPROXIMATE. DUE TO RELOCATION'S PLANNED OR PRESENTLY UNDER CONSTRUCTION THERE ARE SOME UTILITIES THAT WILL BE RELOCATED AND NOT SHOWN ON THESE PLANS. THE CONTRACTOR SHALL BE RESPONSIBLE FOR ANY DAMAGE TO ALL UTILITIES.
 DEPTH & LOCATION OF EXISTING UTILITIES SHALL BE FIELD VERIFIED BY THE CONTRACTOR PRIOR TO CONSTRUCTION.

SEE DRAINAGE AREA MAP SHEETS FOR DRAINAGE SYMBOLOLOGY.

R/W & U/E PURCHASED UNDER JP 09032(05)

POB & ASSOCIATES, OKLAHOMA CITY, OK.
90% PLAN SUBMITTAL
 3/4/2024

AREA
 CUT FILL

VOLUME
 CUT FILL

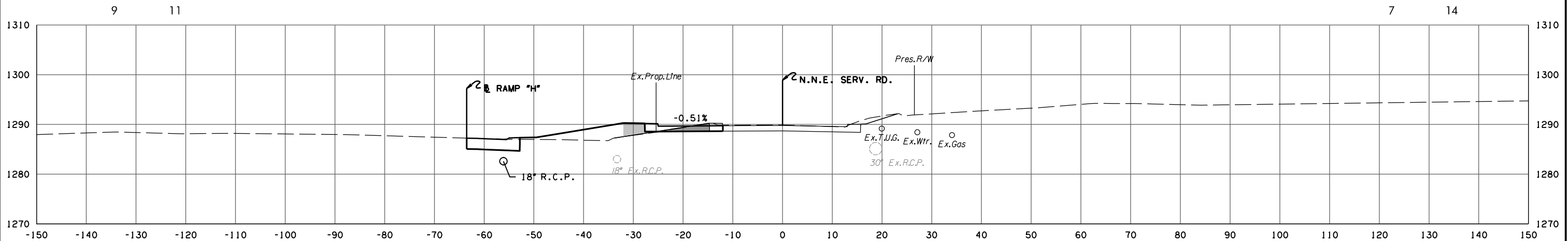

97+00.00

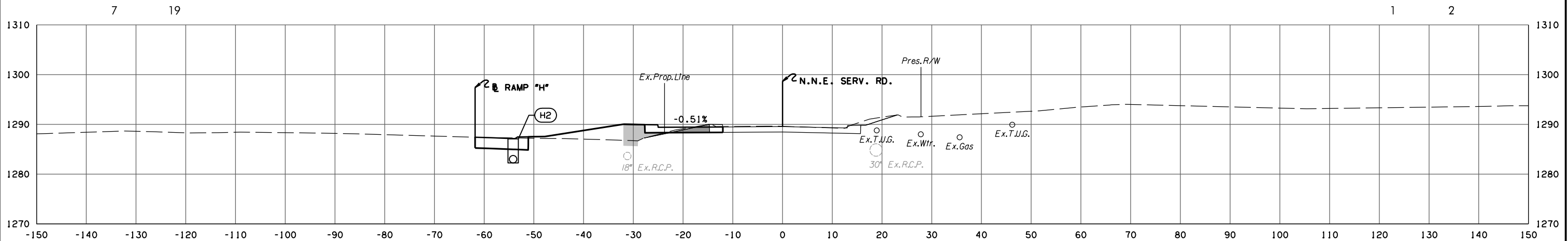

96+74.60

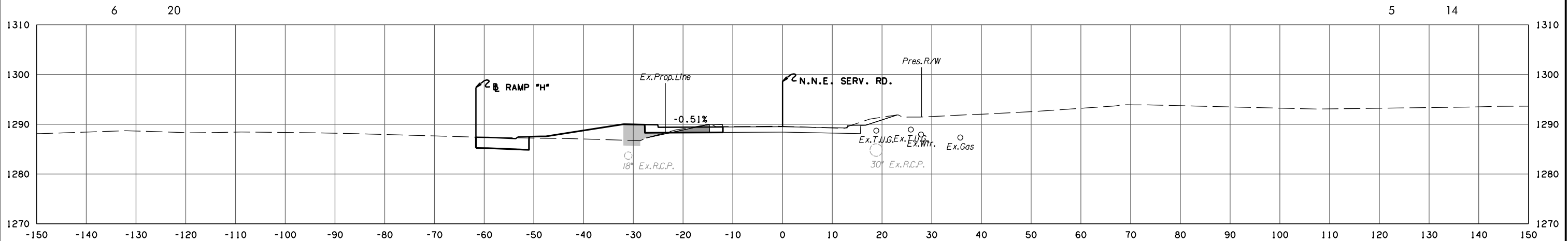

96+72.25
 BEGIN FULL SUPER ROTATION

N.N.E. SERV. RD. PHASE 4
 STATE JOB NO. 09032(08)
 OKLAHOMA COUNTY SHEET NO. X277

3/4/2024 3:59:46 PM H:\PROJECTS\2789_CrossRoads_Phase 4\Roadway\Drawings\Sections\0903208-XSEC_NNE_SERV_RD.dgn

(CAUTION) THE LOCATION OF ALL UTILITIES AS SHOWN ARE APPROXIMATE. DUE TO RELOCATION'S PLANNED OR PRESENTLY UNDER CONSTRUCTION THERE ARE SOME UTILITIES THAT WILL BE RELOCATED AND NOT SHOWN ON THESE PLANS. THE CONTRACTOR SHALL BE RESPONSIBLE FOR ANY DAMAGE TO ALL UTILITIES.
 DEPTH & LOCATION OF EXISTING UTILITIES SHALL BE FIELD VERIFIED BY THE CONTRACTOR PRIOR TO CONSTRUCTION.

SEE DRAINAGE AREA MAP SHEETS FOR DRAINAGE SYMBOLOLOGY.

R/W & U/E PURCHASED UNDER JP 09032(05)

POB & ASSOCIATES, OKLAHOMA CITY, OK.
90% PLAN SUBMITTAL
 3/4/2024

AREA
 CUT FILL

VOLUME
 CUT FILL

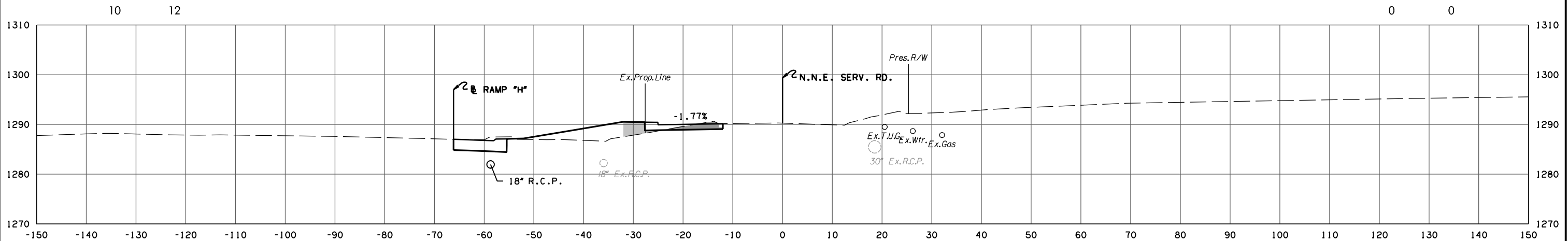

97+32.86

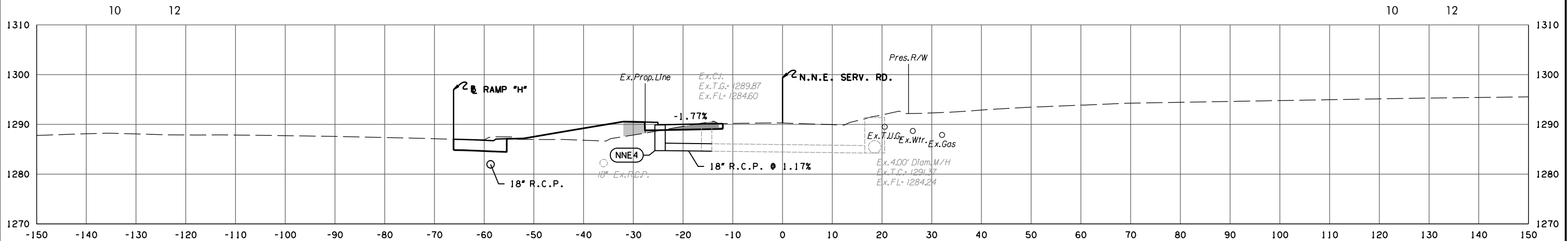

97+32.84

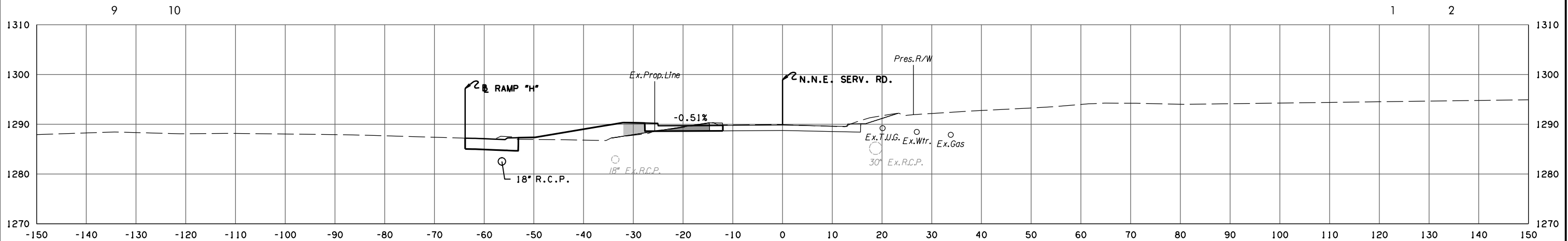

97+04.14
 END FULL SUPER ROTATION

N.N.E. SERV. RD. PHASE 4
 STATE JOB NO. 09032(08)
 OKLAHOMA COUNTY SHEET NO. X278

3/4/2024 3:59:46 PM H:\PROJECTS\2789_CrossRoads_Phase 4\Roadway\Drawings\Sections\0903208-XSEC_NNE SERV RD.dgn

(CAUTION) THE LOCATION OF ALL UTILITIES AS SHOWN ARE APPROXIMATE. DUE TO RELOCATION'S PLANNED OR PRESENTLY UNDER CONSTRUCTION THERE ARE SOME UTILITIES THAT WILL BE RELOCATED AND NOT SHOWN ON THESE PLANS. THE CONTRACTOR SHALL BE RESPONSIBLE FOR ANY DAMAGE TO ALL UTILITIES.
 DEPTH & LOCATION OF EXISTING UTILITIES SHALL BE FIELD VERIFIED BY THE CONTRACTOR PRIOR TO CONSTRUCTION.

SEE DRAINAGE AREA MAP SHEETS FOR DRAINAGE SYMBOLOLOGY.

R/W & U/E PURCHASED UNDER JP 09032(05)

POE & ASSOCIATES, OKLAHOMA CITY, OK.

90% PLAN SUBMITTAL

3/4/2024

AREA
 CUT FILL

VOLUME
 CUT FILL

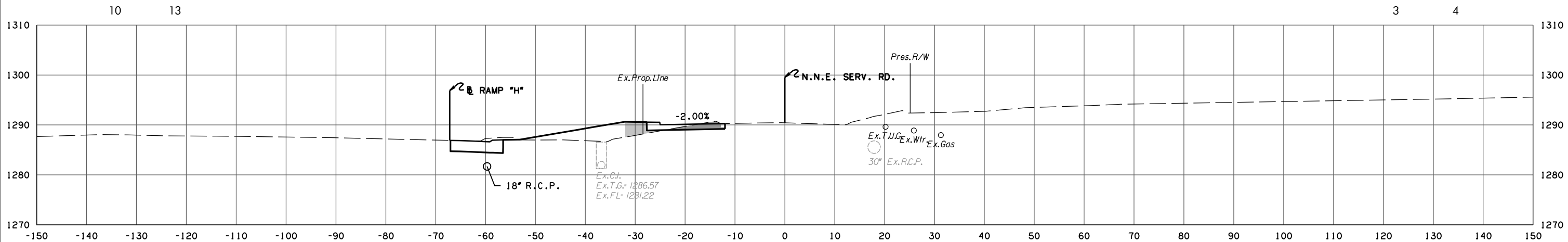

97+46.18

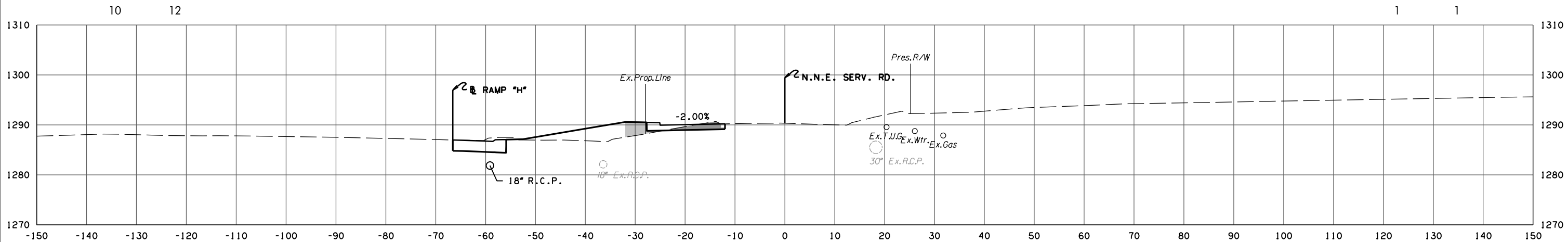

97+38.14
 END SUPER ROTATION

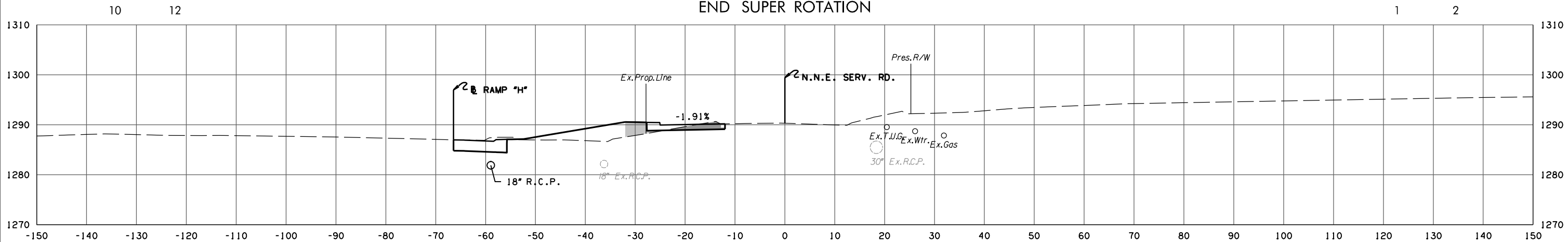

97+36.16

N.N.E. SERV. RD. PHASE 4

STATE JOB NO. 09032(08)
 OKLAHOMA COUNTY SHEET NO. X279

3/4/2024 3:59:47 PM H:\PROJECTS\2789_CrossRoads_Phase 4\Roadway\Drawings\Sections\0903208-XSEC_NNE_SERV_RD.dgn

(CAUTION) THE LOCATION OF ALL UTILITIES AS SHOWN ARE APPROXIMATE. DUE TO RELOCATION'S PLANNED OR PRESENTLY UNDER CONSTRUCTION THERE ARE SOME UTILITIES THAT WILL BE RELOCATED AND NOT SHOWN ON THESE PLANS. THE CONTRACTOR SHALL BE RESPONSIBLE FOR ANY DAMAGE TO ALL UTILITIES.

SEE DRAINAGE AREA MAP SHEETS FOR DRAINAGE SYMBOLOLOGY.

R/W & U/E PURCHASED UNDER JP 09032(05)

POB & ASSOCIATES, OKLAHOMA CITY, OK.

**90% PLAN
SUBMITTAL**

3/4/2024

AREA
CUT FILL

VOLUME
CUT FILL

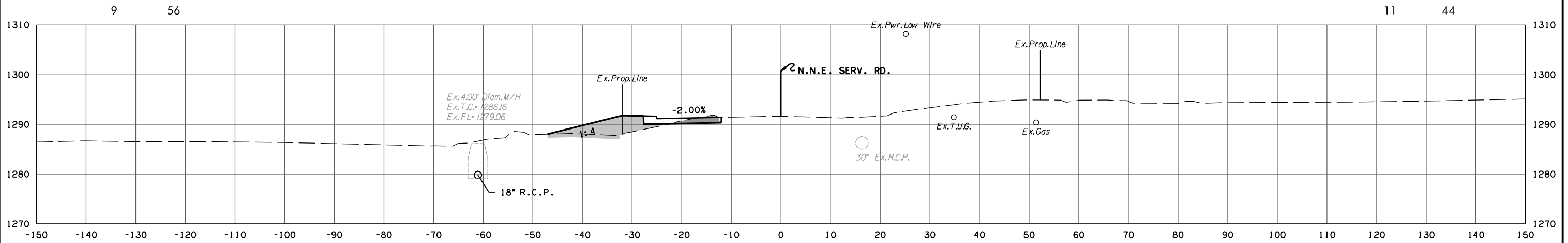

98+54.61

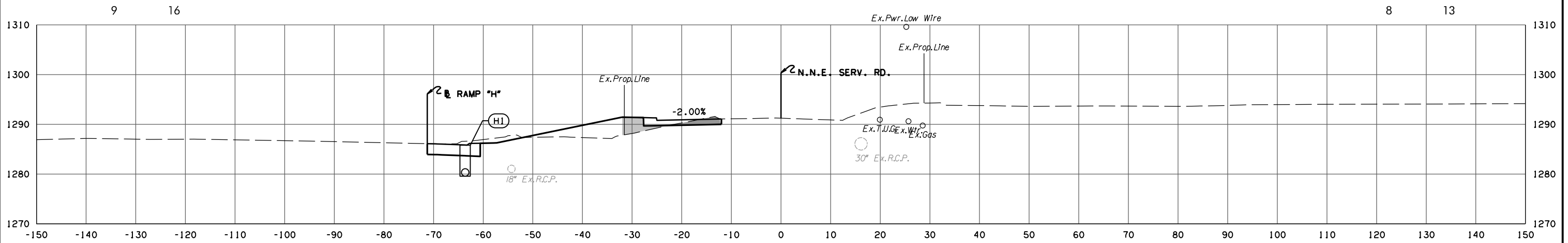

98+22.17

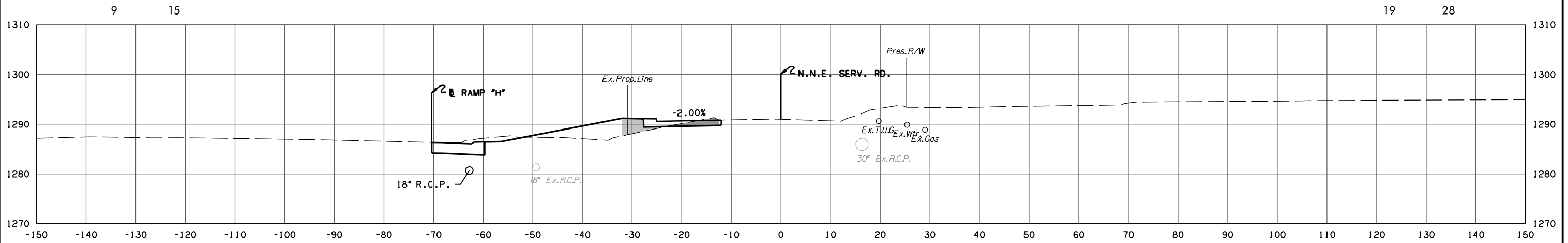

98+00.00

N.N.E. SERV. RD. PHASE 4

STATE JOB NO. 09032(08)
OKLAHOMA COUNTY SHEET NO. X280

3/4/2024 3:59:48 PM H:\PROJECTS\2789_CrossRoads_Phase 4\Roadway\Drawings\Sections\0903208-XSEC_NNE_SERV_RD.dgn

(CAUTION) THE LOCATION OF ALL UTILITIES AS SHOWN ARE APPROXIMATE. DUE TO RELOCATION'S PLANNED OR PRESENTLY UNDER CONSTRUCTION THERE ARE SOME UTILITIES THAT WILL BE RELOCATED AND NOT SHOWN ON THESE PLANS. THE CONTRACTOR SHALL BE RESPONSIBLE FOR ANY DAMAGE TO ALL UTILITIES.

DEPTH & LOCATION OF EXISTING UTILITIES SHALL BE FIELD VERIFIED BY THE CONTRACTOR PRIOR TO CONSTRUCTION.

SEE DRAINAGE AREA MAP SHEETS FOR DRAINAGE SYMBOLOLOGY.

R/W & U/E PURCHASED UNDER JP 09032(05)

POB & ASSOCIATES, OKLAHOMA CITY, OK.

**90% PLAN
SUBMITTAL**

3/4/2024

AREA
CUT FILL

VOLUME
CUT FILL

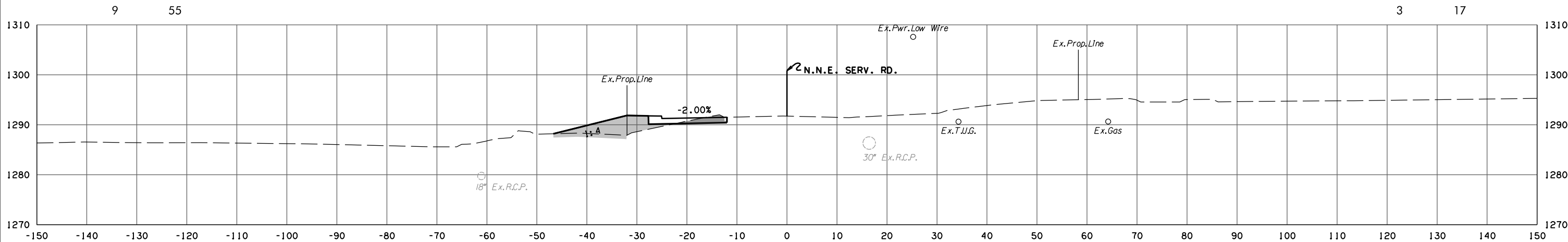
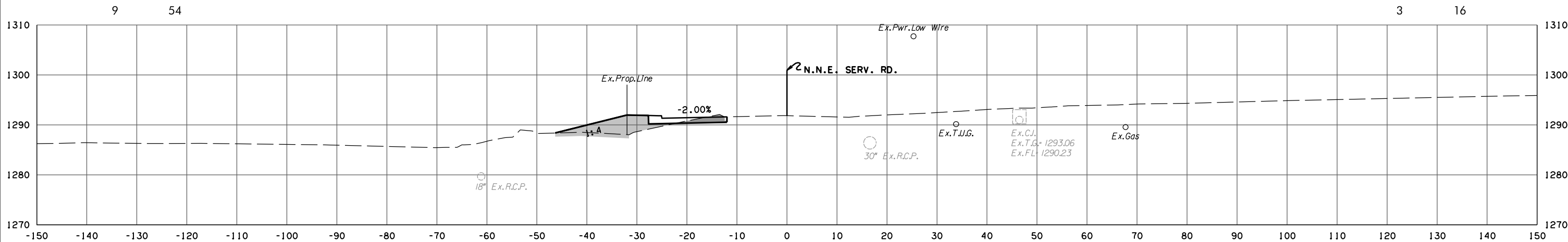
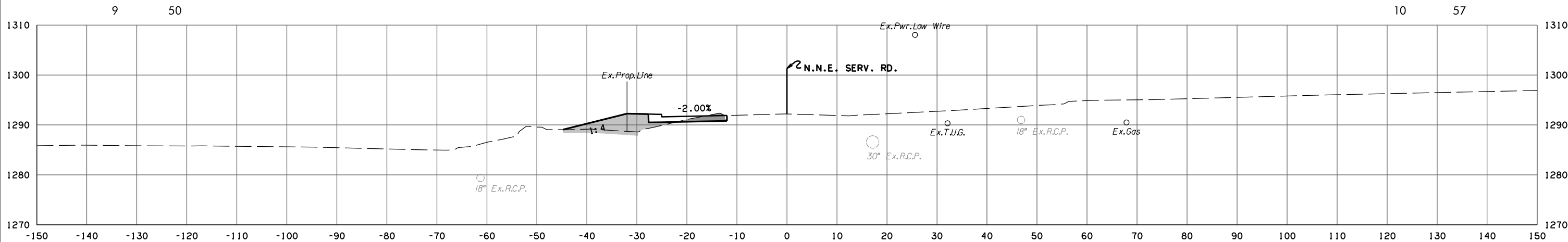

N.N.E. SERV. RD. PHASE 4

STATE JOB NO.	09032(08)
OKLAHOMA COUNTY	SHEET NO. X281

3/4/2024 3:59:48 PM
H:\PROJECTS\2789_CrossRoads_Phase 4\Roadway\Drawings\Sections\0903208-XSEC_NNE_SERV_RD.dgn

(CAUTION) THE LOCATION OF ALL UTILITIES AS SHOWN ARE APPROXIMATE. DUE TO RELOCATION'S PLANNED OR PRESENTLY UNDER CONSTRUCTION THERE ARE SOME UTILITIES THAT WILL BE RELOCATED AND NOT SHOWN ON THESE PLANS. THE CONTRACTOR SHALL BE RESPONSIBLE FOR ANY DAMAGE TO ALL UTILITIES.

DEPTH & LOCATION OF EXISTING UTILITIES SHALL BE FIELD VERIFIED BY THE CONTRACTOR PRIOR TO CONSTRUCTION.

SEE DRAINAGE AREA MAP SHEETS FOR DRAINAGE SYMBOLOLOGY.

R/W & U/E PURCHASED UNDER JP 09032(05)

POB & ASSOCIATES, OKLAHOMA CITY, OK.

**90% PLAN
SUBMITTAL**

3/4/2024

AREA
CUT FILL

VOLUME
CUT FILL

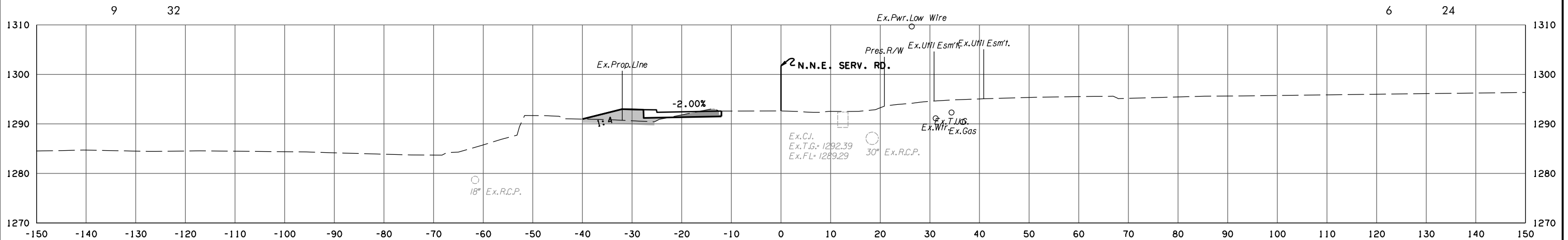

99+72.56

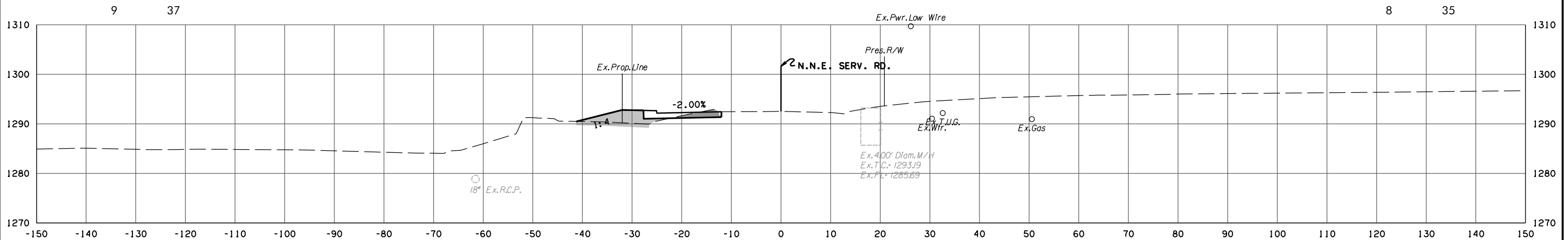

99+53.61

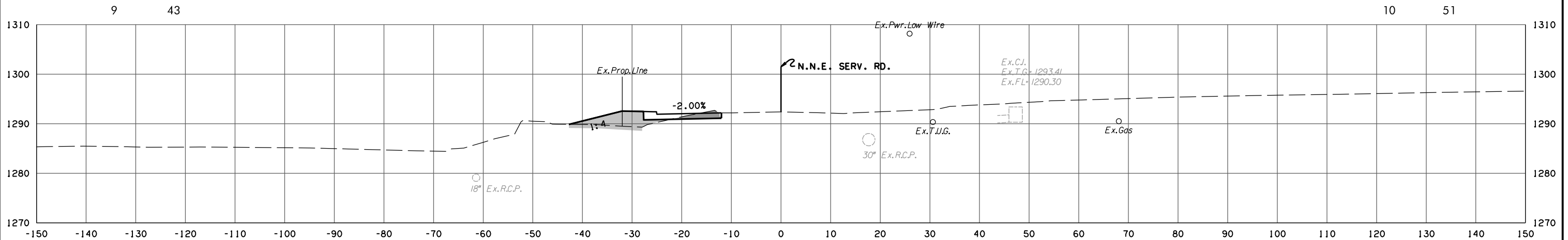

99+29.86

N.N.E. SERV. RD. PHASE 4

STATE JOB NO. 09032(08)
OKLAHOMA COUNTY SHEET NO. X282

3/4/2024 3:59:49 PM H:\PROJECTS\2789_CrossRoads_Phase 4\Roadway\Drawings\Sections\0903208-XSEC_NNE_SERV_RD.dgn

(CAUTION) THE LOCATION OF ALL UTILITIES AS SHOWN ARE APPROXIMATE. DUE TO RELOCATION'S PLANNED OR PRESENTLY UNDER CONSTRUCTION THERE ARE SOME UTILITIES THAT WILL BE RELOCATED AND NOT SHOWN ON THESE PLANS. THE CONTRACTOR SHALL BE RESPONSIBLE FOR ANY DAMAGE TO ALL UTILITIES.

SEE DRAINAGE AREA MAP SHEETS FOR DRAINAGE SYMBOLOLOGY.

R/W & U/E PURCHASED UNDER JP 09032(05)

POE & ASSOCIATES, OKLAHOMA CITY, OK.

**90% PLAN
SUBMITTAL**

3/4/2024

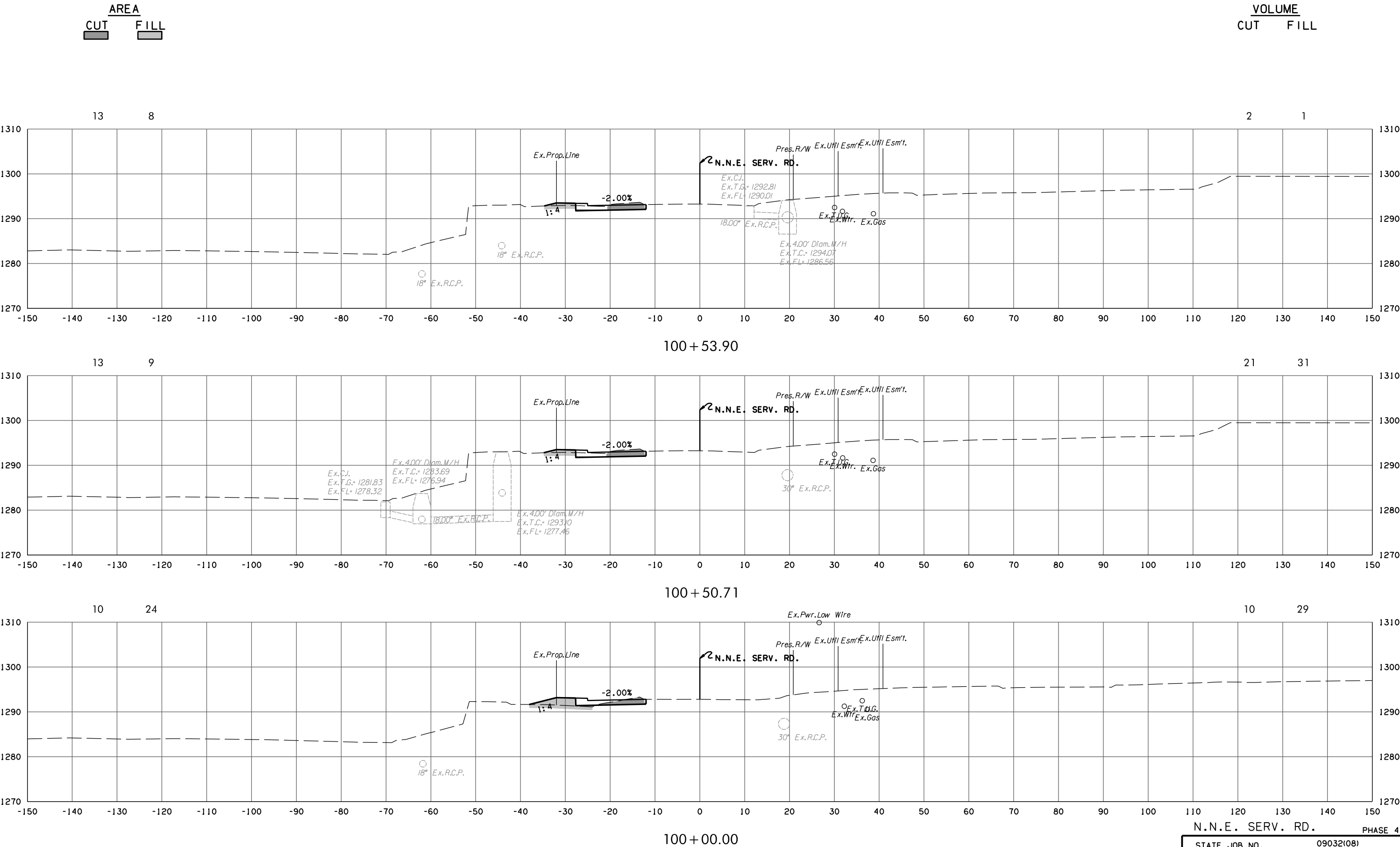

AREA
CUT FILL

VOLUME
CUT FILL

100+53.90

100+50.71

100+00.00

N.N.E. SERV. RD. PHASE 4
STATE JOB NO. 09032(08)
OKLAHOMA COUNTY SHEET NO. X283

3/4/2024 3:59:49 PM H:\PROJECTS\2789_CrossRoads_Phase 4\Roadway\Drawings\Sections\0903208-XSEC_NNE_SERV_RD.dgn

(CAUTION) THE LOCATION OF ALL UTILITIES AS SHOWN ARE APPROXIMATE. DUE TO RELOCATION'S PLANNED OR PRESENTLY UNDER CONSTRUCTION THERE ARE SOME UTILITIES THAT WILL BE RELOCATED AND NOT SHOWN ON THESE PLANS. THE CONTRACTOR SHALL BE RESPONSIBLE FOR ANY DAMAGE TO ALL UTILITIES.
 DEPTH & LOCATION OF EXISTING UTILITIES SHALL BE FIELD VERIFIED BY THE CONTRACTOR PRIOR TO CONSTRUCTION.

SEE DRAINAGE AREA MAP SHEETS FOR DRAINAGE SYMBOLOLOGY.

R/W & U/E PURCHASED UNDER JP 09032(05)

POB & ASSOCIATES, OKLAHOMA CITY, OK.
90% PLAN SUBMITTAL
 3/4/2024

AREA
 CUT FILL

VOLUME
 CUT FILL

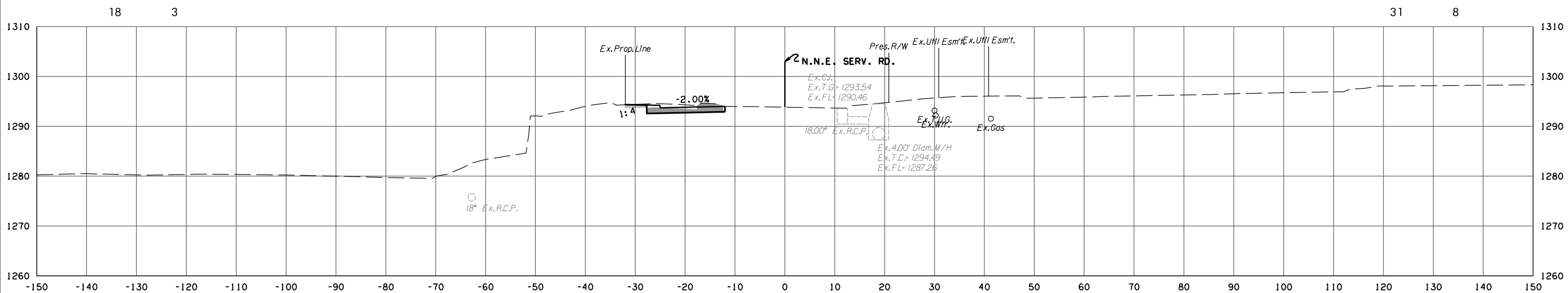

101+54.47

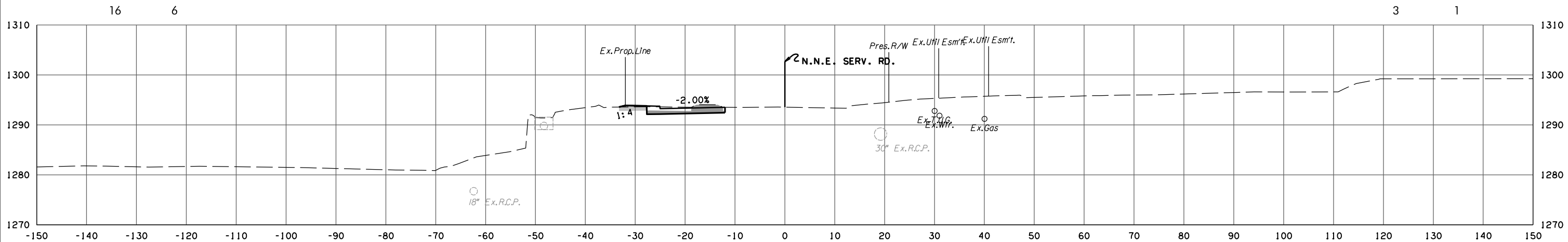

101+04.57

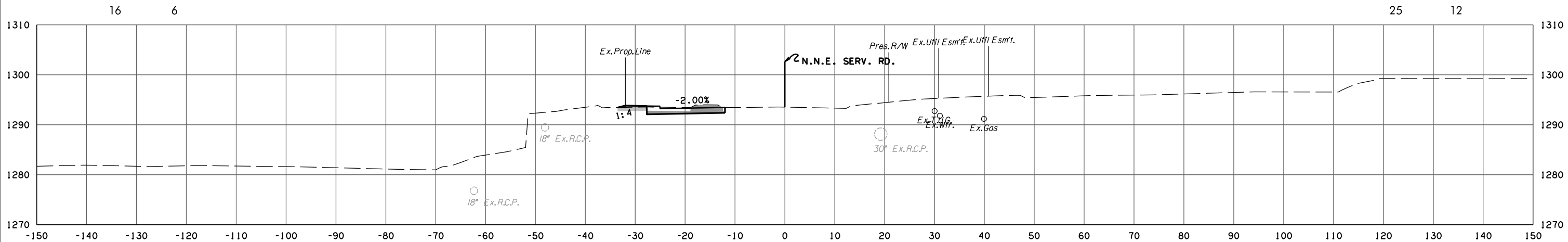

101+00.00

N.N.E. SERV. RD. PHASE 4
 STATE JOB NO. 09032(08)
 OKLAHOMA COUNTY SHEET NO. X284

3/4/2024 3:59:50 PM
 H:\PROJECTS\2789_CrossRoads_Phase 4\Roadway\Drawings\Sections\0903208-XSEC_NNE_SERV_RD.dgn

(CAUTION) THE LOCATION OF ALL UTILITIES AS SHOWN ARE APPROXIMATE. DUE TO RELOCATION'S PLANNED OR PRESENTLY UNDER CONSTRUCTION THERE ARE SOME UTILITIES THAT WILL BE RELOCATED AND NOT SHOWN ON THESE PLANS. THE CONTRACTOR SHALL BE RESPONSIBLE FOR ANY DAMAGE TO ALL UTILITIES.
 DEPTH & LOCATION OF EXISTING UTILITIES SHALL BE FIELD VERIFIED BY THE CONTRACTOR PRIOR TO CONSTRUCTION.

SEE DRAINAGE AREA MAP SHEETS FOR DRAINAGE SYMBOLOLOGY.

R/W & U/E PURCHASED UNDER JP 09032(05)

POB & ASSOCIATES, OKLAHOMA CITY, OK.
90% PLAN SUBMITTAL
 3/4/2024

AREA
 CUT FILL

VOLUME
 CUT FILL

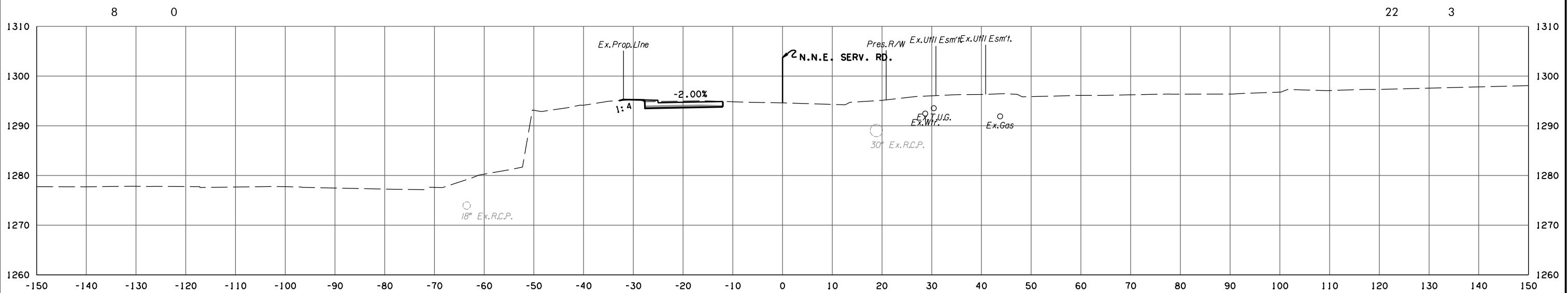

102 + 48.85

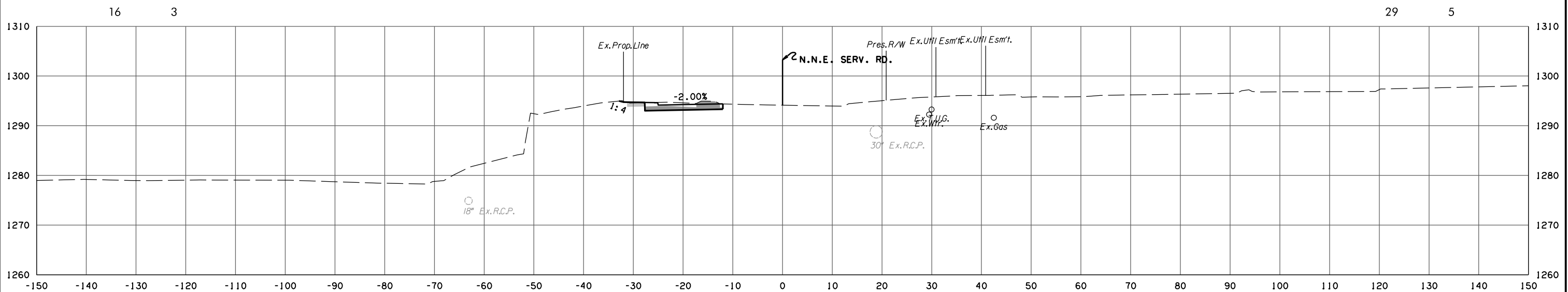

102 + 00.00

N.N.E. SERV. RD. PHASE 4

STATE JOB NO. 09032(08)
 OKLAHOMA COUNTY SHEET NO. X285

3/4/2024 3:59:51 PM H:\PROJECTS\2785_CrossRoads_Phase 4\Roadway\Drawings\Sections\0903208-XSEC_NNE_SERV_RD.dgn

(CAUTION) THE LOCATION OF ALL UTILITIES AS SHOWN ARE APPROXIMATE. DUE TO RELOCATION'S PLANNED OR PRESENTLY UNDER CONSTRUCTION THERE ARE SOME UTILITIES THAT WILL BE RELOCATED AND NOT SHOWN ON THESE PLANS. THE CONTRACTOR SHALL BE RESPONSIBLE FOR ANY DAMAGE TO ALL UTILITIES.

DEPTH & LOCATION OF EXISTING UTILITIES SHALL BE FIELD VERIFIED BY THE CONTRACTOR PRIOR TO CONSTRUCTION.

SEE DRAINAGE AREA MAP SHEETS FOR DRAINAGE SYMBOLOLOGY.

R/W & U/E PURCHASED UNDER JP 09032(05)

POB & ASSOCIATES, OKLAHOMA CITY, OK.

**90% PLAN
SUBMITTAL**

3/4/2024

AREA
CUT FILL

VOLUME
CUT FILL

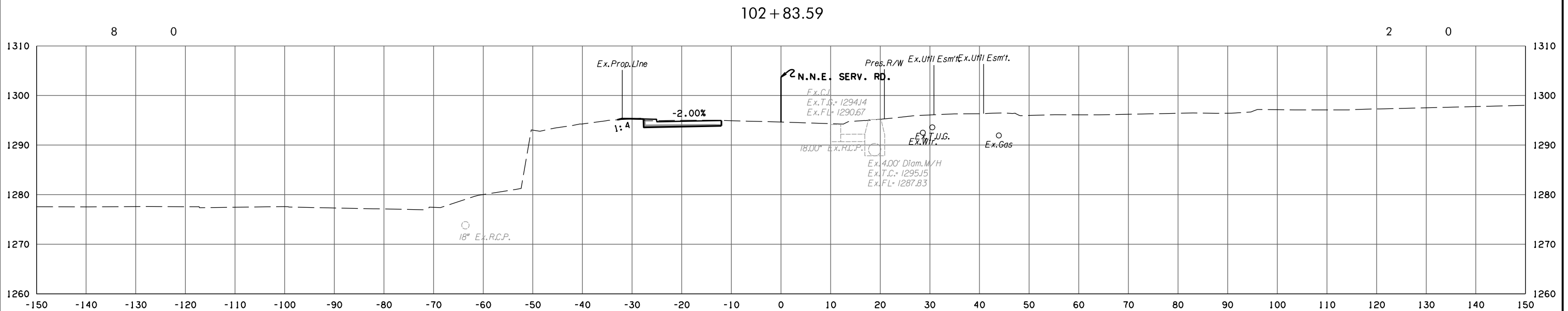
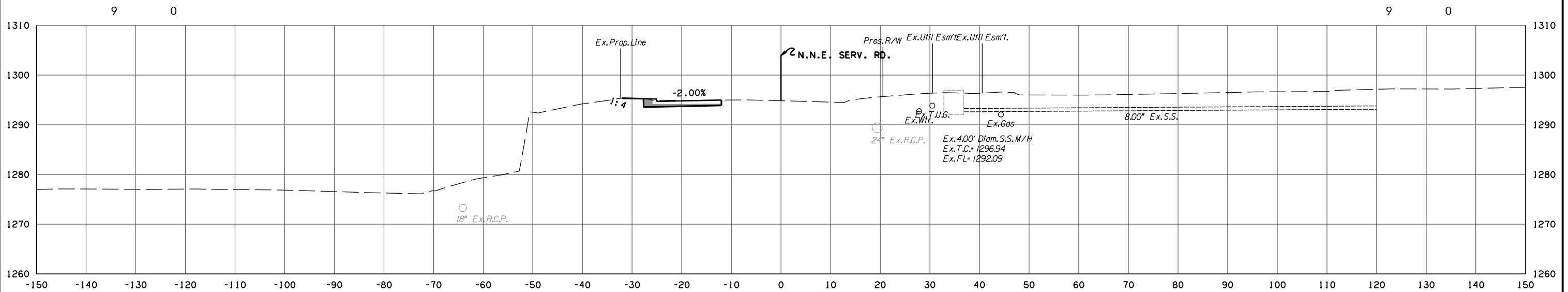

3/4/2024 3:59:51 PM H:\PROJECTS\2789_CrossRoads_Phase 4\Roadway\Drawings\Sections\0903208-XSEC-NNE SERV RD.dgn



N.N.E. SERV. RD. PHASE 4
STATE JOB NO. 09032(08)
OKLAHOMA COUNTY SHEET NO. X286

(CAUTION) THE LOCATION OF ALL UTILITIES AS SHOWN ARE APPROXIMATE. DUE TO RELOCATION'S PLANNED OR PRESENTLY UNDER CONSTRUCTION THERE ARE SOME UTILITIES THAT WILL BE RELOCATED AND NOT SHOWN ON THESE PLANS. THE CONTRACTOR SHALL BE RESPONSIBLE FOR ANY DAMAGE TO ALL UTILITIES.
 DEPTH & LOCATION OF EXISTING UTILITIES SHALL BE FIELD VERIFIED BY THE CONTRACTOR PRIOR TO CONSTRUCTION.

SEE DRAINAGE AREA MAP SHEETS FOR DRAINAGE SYMBOLOLOGY.

R/W & U/E PURCHASED UNDER JP 09032(05)

POB & ASSOCIATES, OKLAHOMA CITY, OK.
90% PLAN SUBMITTAL
 3/4/2024

AREA
 CUT  FILL 

VOLUME
 CUT FILL

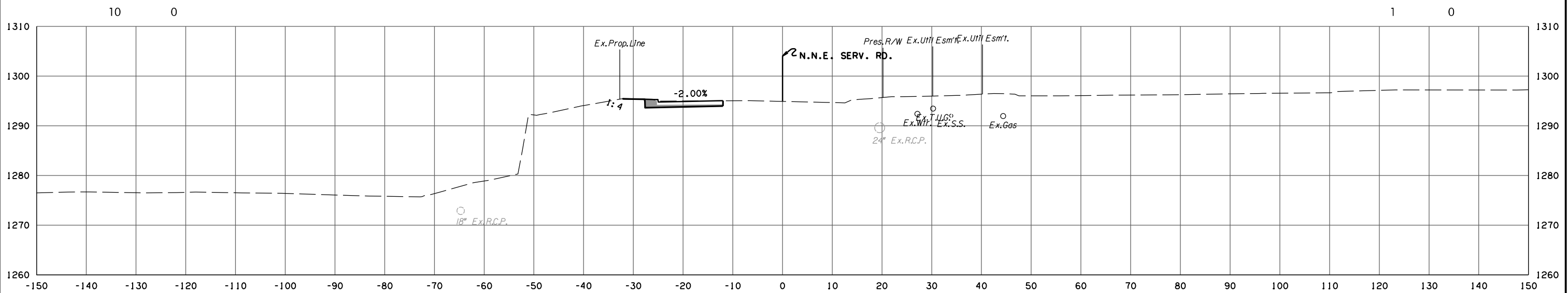

103 + 02.13
 BEGIN ROTATION

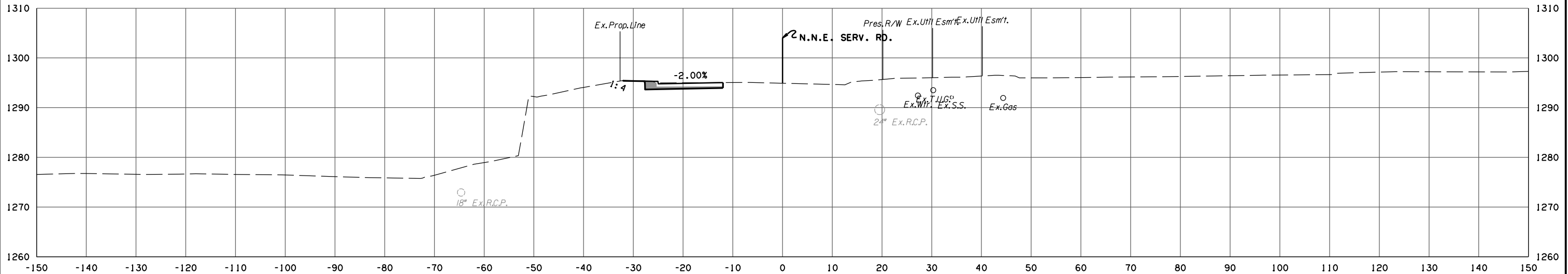

103 + 00.00

N.N.E. SERV. RD. PHASE 4
 STATE JOB NO. 09032(08)
 OKLAHOMA COUNTY SHEET NO. X287



3/4/2024 3:59:52 PM H:\PROJECTS\2789_CrossRoads_Phase 4\Roadway\Drawings\Sections\0903208-XSEC_NNE_SERV_RD.dgn

(CAUTION) THE LOCATION OF ALL UTILITIES AS SHOWN ARE APPROXIMATE. DUE TO RELOCATION'S PLANNED OR PRESENTLY UNDER CONSTRUCTION THERE ARE SOME UTILITIES THAT WILL BE RELOCATED AND NOT SHOWN ON THESE PLANS. THE CONTRACTOR SHALL BE RESPONSIBLE FOR ANY DAMAGE TO ALL UTILITIES.
 DEPTH & LOCATION OF EXISTING UTILITIES SHALL BE FIELD VERIFIED BY THE CONTRACTOR PRIOR TO CONSTRUCTION.

SEE DRAINAGE AREA MAP SHEETS FOR DRAINAGE SYMBOLOLOGY.

R/W & U/E PURCHASED UNDER JP 09032(05)

POB & ASSOCIATES, OKLAHOMA CITY, OK.
90% PLAN
SUBMITTAL
 3/4/2024

AREA
 CUT  FILL 

VOLUME
 CUT FILL

3/4/2024 3:59:52 PM H:\PROJECTS\2789_CrossRoads_Phase 4\Roadway\Drawings\Sections\0903208-XSEC-NNE SERV RD.dgn

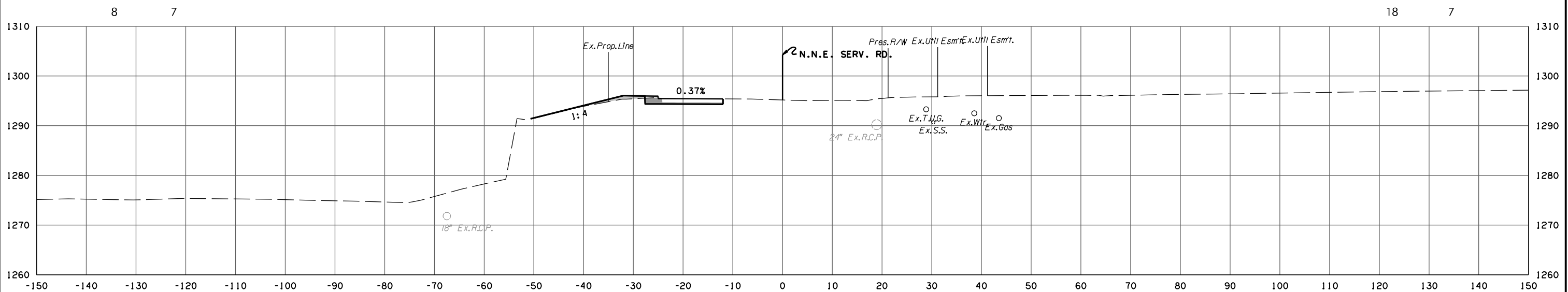

END ROTATION 103 + 56.13 END CONSTRUCTION

N.N.E. SERV. RD. PHASE 4
 STATE JOB NO. 09032(08)
 OKLAHOMA COUNTY SHEET NO. X288

(CAUTION) THE LOCATION OF ALL UTILITIES AS SHOWN ARE APPROXIMATE. DUE TO RELOCATION'S PLANNED OR PRESENTLY UNDER CONSTRUCTION THERE ARE SOME UTILITIES THAT WILL BE RELOCATED AND NOT SHOWN ON THESE PLANS. THE CONTRACTOR SHALL BE RESPONSIBLE FOR ANY DAMAGE TO ALL UTILITIES.

DEPTH & LOCATION OF EXISTING UTILITIES SHALL BE FIELD VERIFIED BY THE CONTRACTOR PRIOR TO CONSTRUCTION.

SEE DRAINAGE AREA MAP SHEETS FOR DRAINAGE SYMBOLOLOGY.

R/W & U/E PURCHASED UNDER JP 09032(05)

POB & ASSOCIATES, OKLAHOMA CITY, OK.

**90% PLAN
SUBMITTAL**

3/4/2024

AREA
CUT FILL

VOLUME
CUT FILL

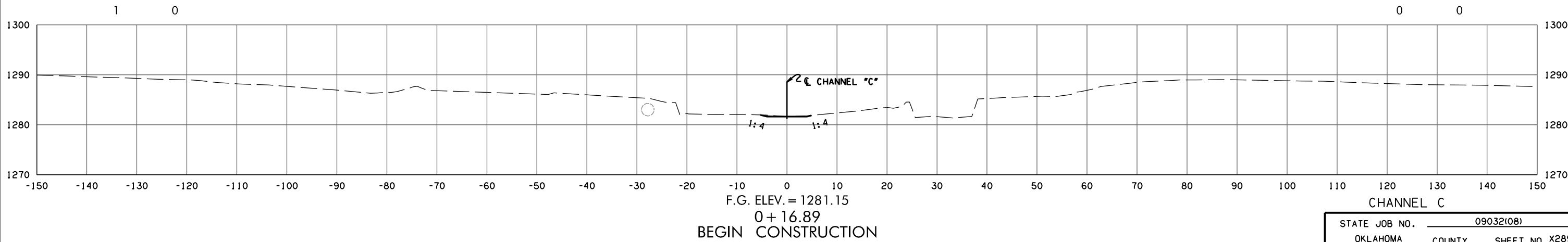
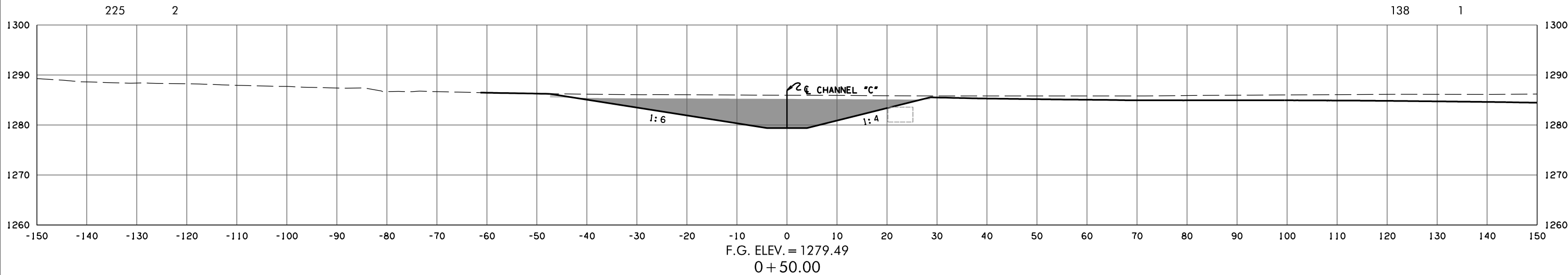

STATE JOB NO. 09032(08)
OKLAHOMA COUNTY SHEET NO. X289

3/4/2024 3:59:53 PM
H:\PROJECTS\2789_CrossRoads_Phase 4\Roadway\Drawings\Sections\0903208-XSEC.CHANNEL C.dgn

(CAUTION) THE LOCATION OF ALL UTILITIES AS SHOWN ARE APPROXIMATE. DUE TO RELOCATION'S PLANNED OR PRESENTLY UNDER CONSTRUCTION THERE ARE SOME UTILITIES THAT WILL BE RELOCATED AND NOT SHOWN ON THESE PLANS. THE CONTRACTOR SHALL BE RESPONSIBLE FOR ANY DAMAGE TO ALL UTILITIES.
 DEPTH & LOCATION OF EXISTING UTILITIES SHALL BE FIELD VERIFIED BY THE CONTRACTOR PRIOR TO CONSTRUCTION.

SEE DRAINAGE AREA MAP SHEETS FOR DRAINAGE SYMBOLOLOGY.

R/W & U/E PURCHASED UNDER JP 09032(05)

POB & ASSOCIATES, OKLAHOMA CITY, OK.
90% PLAN
SUBMITTAL
 3/4/2024

AREA
 CUT FILL

VOLUME
 CUT FILL

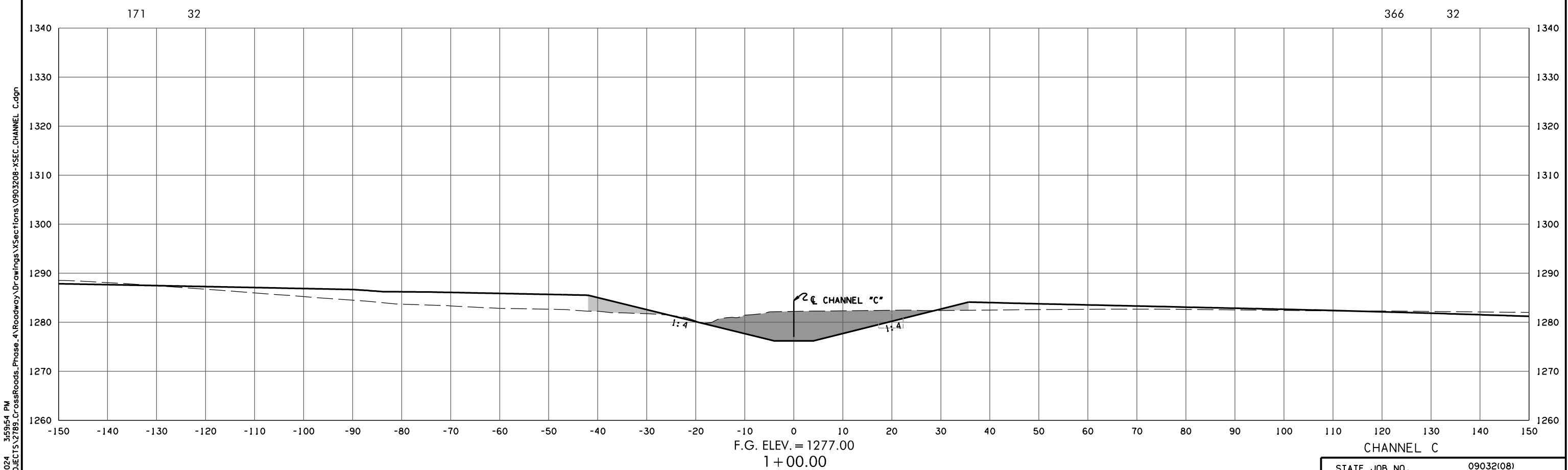

3/4/2024 3:59:54 PM H:\PROJECTS\2789_CrossRoads_Phase 4\Roadway\Drawings\Sections\0903208-XSEC.CHANNEL C.dgn

STATE JOB NO. 09032(08)
 OKLAHOMA COUNTY SHEET NO. X290

(CAUTION) THE LOCATION OF ALL UTILITIES AS SHOWN ARE APPROXIMATE. DUE TO RELOCATION'S PLANNED OR PRESENTLY UNDER CONSTRUCTION THERE ARE SOME UTILITIES THAT WILL BE RELOCATED AND NOT SHOWN ON THESE PLANS. THE CONTRACTOR SHALL BE RESPONSIBLE FOR ANY DAMAGE TO ALL UTILITIES.
 DEPTH & LOCATION OF EXISTING UTILITIES SHALL BE FIELD VERIFIED BY THE CONTRACTOR PRIOR TO CONSTRUCTION.

SEE DRAINAGE AREA MAP SHEETS FOR DRAINAGE SYMBOLOLOGY.

R/W & U/E PURCHASED UNDER JP 09032(05)

POB & ASSOCIATES, OKLAHOMA CITY, OK.
90% PLAN
SUBMITTAL
 3/4/2024

AREA
 CUT FILL

VOLUME
 CUT FILL

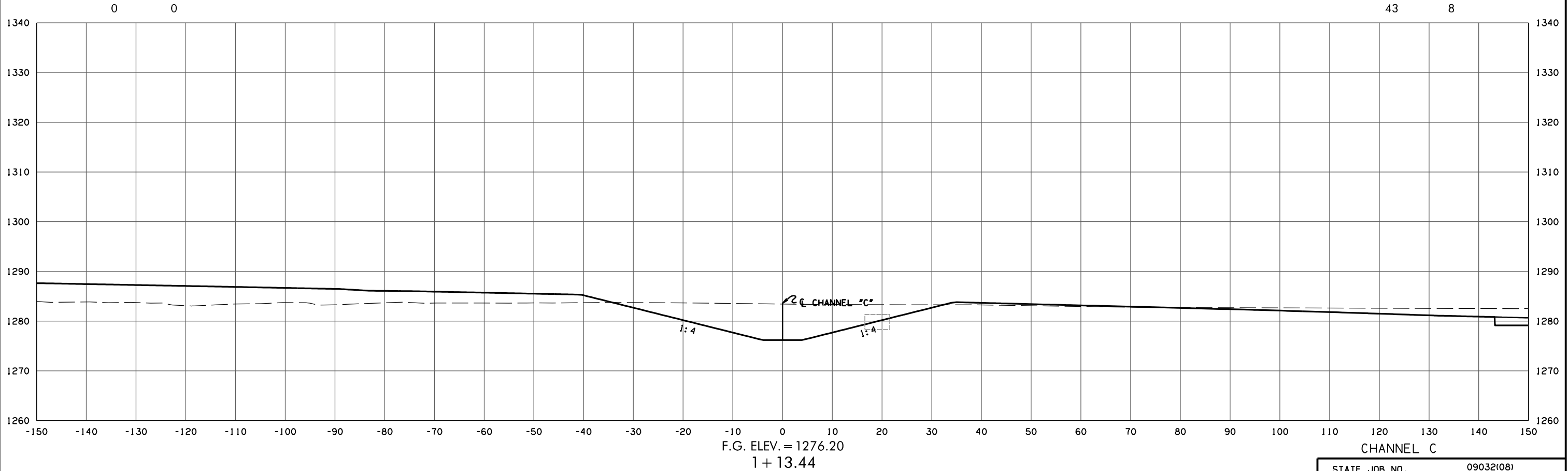
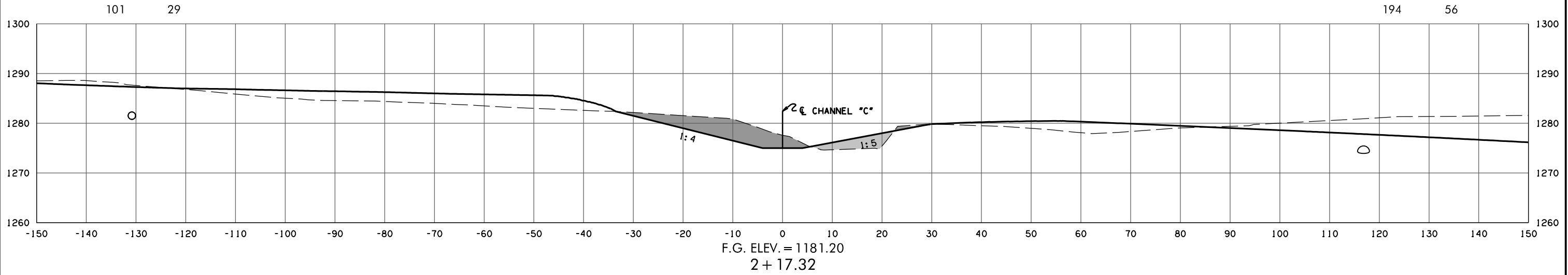

CHANNEL C
 STATE JOB NO. 09032(08)
 OKLAHOMA COUNTY SHEET NO. X291

3/4/2024 3:59:54 PM H:\PROJECTS\2789_CrossRoads_Phase 4\Roadway\Drawings\Sections\0903208-XSEC.CHANNEL C.dgn

(CAUTION) THE LOCATION OF ALL UTILITIES AS SHOWN ARE APPROXIMATE. DUE TO RELOCATION'S PLANNED OR PRESENTLY UNDER CONSTRUCTION THERE ARE SOME UTILITIES THAT WILL BE RELOCATED AND NOT SHOWN ON THESE PLANS. THE CONTRACTOR SHALL BE RESPONSIBLE FOR ANY DAMAGE TO ALL UTILITIES.
 DEPTH & LOCATION OF EXISTING UTILITIES SHALL BE FIELD VERIFIED BY THE CONTRACTOR PRIOR TO CONSTRUCTION.

SEE DRAINAGE AREA MAP SHEETS FOR DRAINAGE SYMBOLOLOGY.

R/W & U/E PURCHASED UNDER JP 09032(05)

POB & ASSOCIATES, OKLAHOMA CITY, OK.
90% PLAN SUBMITTAL
 3/4/2024

AREA
 CUT FILL

VOLUME
 CUT FILL

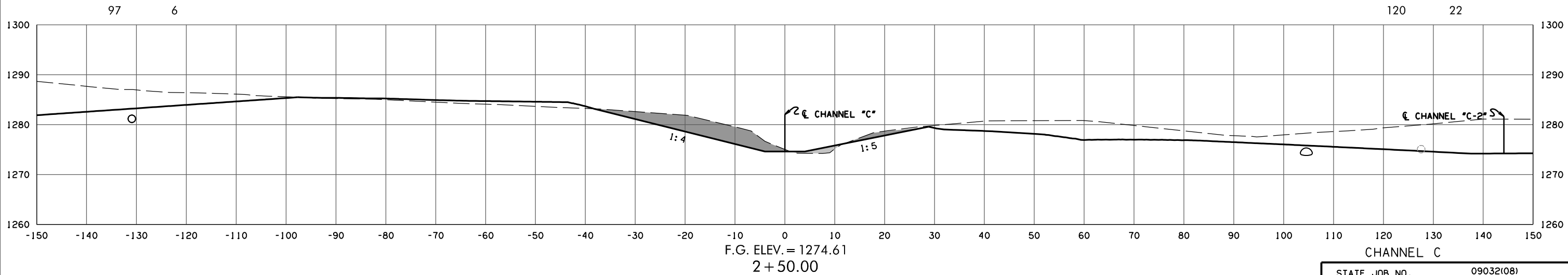
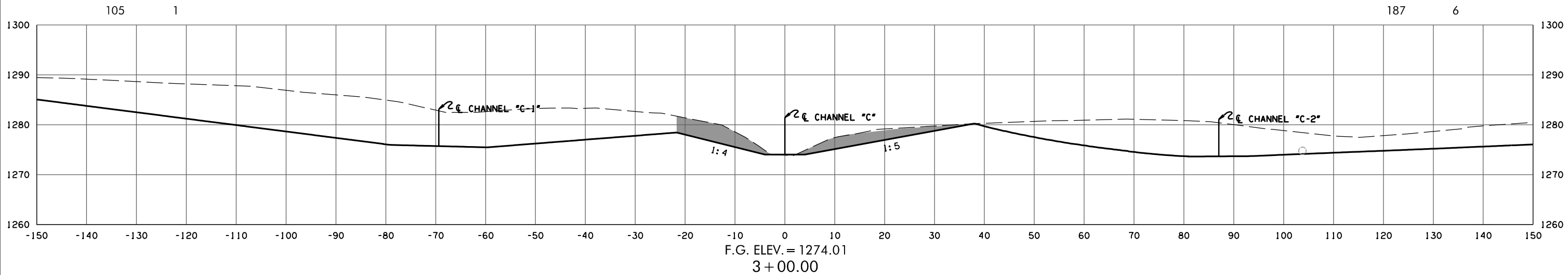
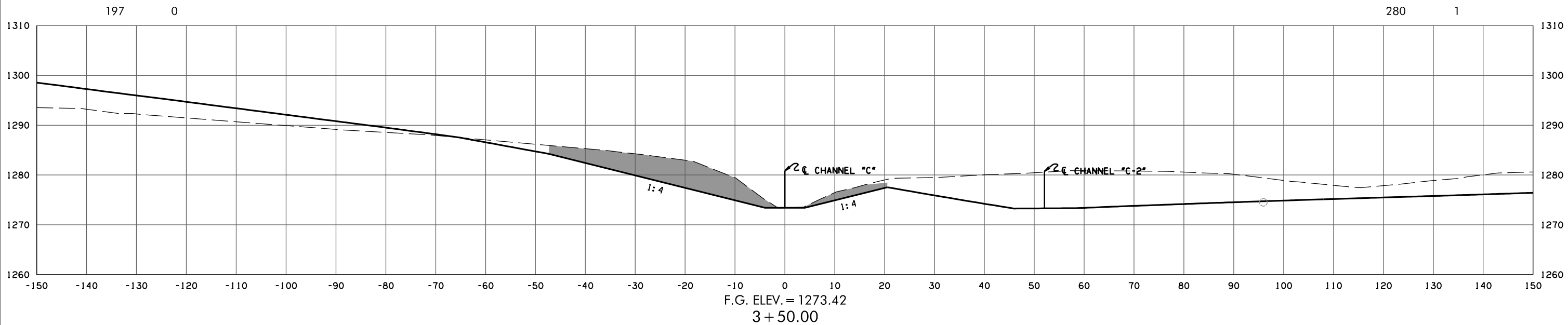

CHANNEL C
 STATE JOB NO. 09032(08)
 OKLAHOMA COUNTY SHEET NO. X292

3/4/2024 3:59:55 PM
 H:\PROJECTS\2789_CrossRoads_Phase 4\Roadway\Drawings\Sections\0903208-XSEC.CHANNEL C.dgn

(CAUTION) THE LOCATION OF ALL UTILITIES AS SHOWN ARE APPROXIMATE. DUE TO RELOCATION'S PLANNED OR PRESENTLY UNDER CONSTRUCTION THERE ARE SOME UTILITIES THAT WILL BE RELOCATED AND NOT SHOWN ON THESE PLANS. THE CONTRACTOR SHALL BE RESPONSIBLE FOR ANY DAMAGE TO ALL UTILITIES.
 DEPTH & LOCATION OF EXISTING UTILITIES SHALL BE FIELD VERIFIED BY THE CONTRACTOR PRIOR TO CONSTRUCTION.

SEE DRAINAGE AREA MAP SHEETS FOR DRAINAGE SYMBOLOLOGY.

R/W & U/E PURCHASED UNDER JP 09032(05)

POB & ASSOCIATES, OKLAHOMA CITY, OK.
90% PLAN
SUBMITTAL
 3/4/2024

AREA
 CUT FILL

VOLUME
 CUT FILL

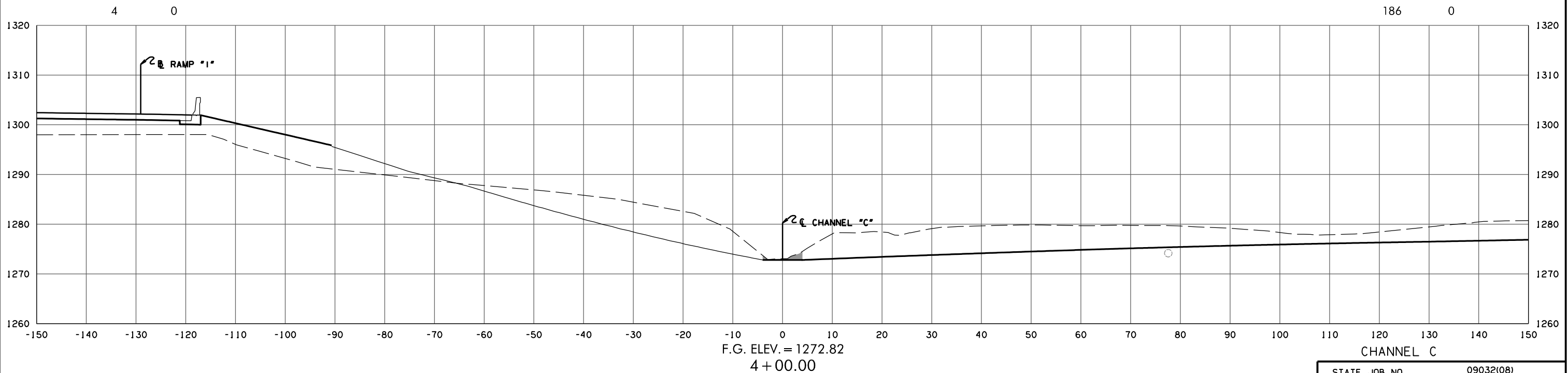
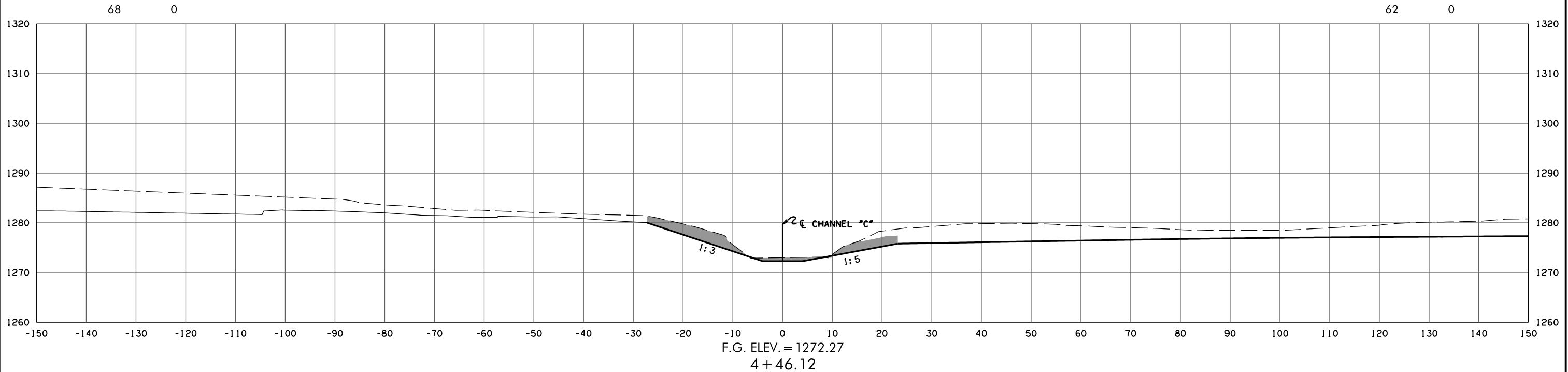

CHANNEL C
 STATE JOB NO. 09032(08)
 OKLAHOMA COUNTY SHEET NO. X293

3/4/2024 3:59:56 PM H:\PROJECTS\2789_CrossRoads_Phase 4\Roadway\Drawings\Sections\0903208-XSEC.CHANNEL C.dgn

(CAUTION) THE LOCATION OF ALL UTILITIES AS SHOWN ARE APPROXIMATE. DUE TO RELOCATION'S PLANNED OR PRESENTLY UNDER CONSTRUCTION THERE ARE SOME UTILITIES THAT WILL BE RELOCATED AND NOT SHOWN ON THESE PLANS. THE CONTRACTOR SHALL BE RESPONSIBLE FOR ANY DAMAGE TO ALL UTILITIES.
 DEPTH & LOCATION OF EXISTING UTILITIES SHALL BE FIELD VERIFIED BY THE CONTRACTOR PRIOR TO CONSTRUCTION.

SEE DRAINAGE AREA MAP SHEETS FOR DRAINAGE SYMBOLOLOGY.

R/W & U/E PURCHASED UNDER JP 09032(05)

POB & ASSOCIATES, OKLAHOMA CITY, OK.

**90% PLAN
 SUBMITTAL**

3/4/2024

AREA
 CUT FILL

VOLUME
 CUT FILL

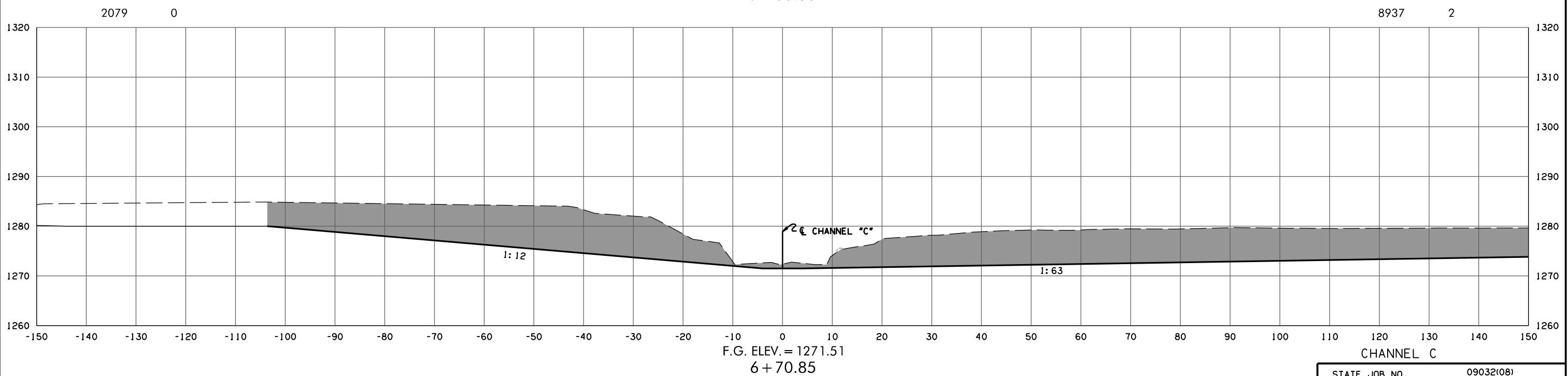
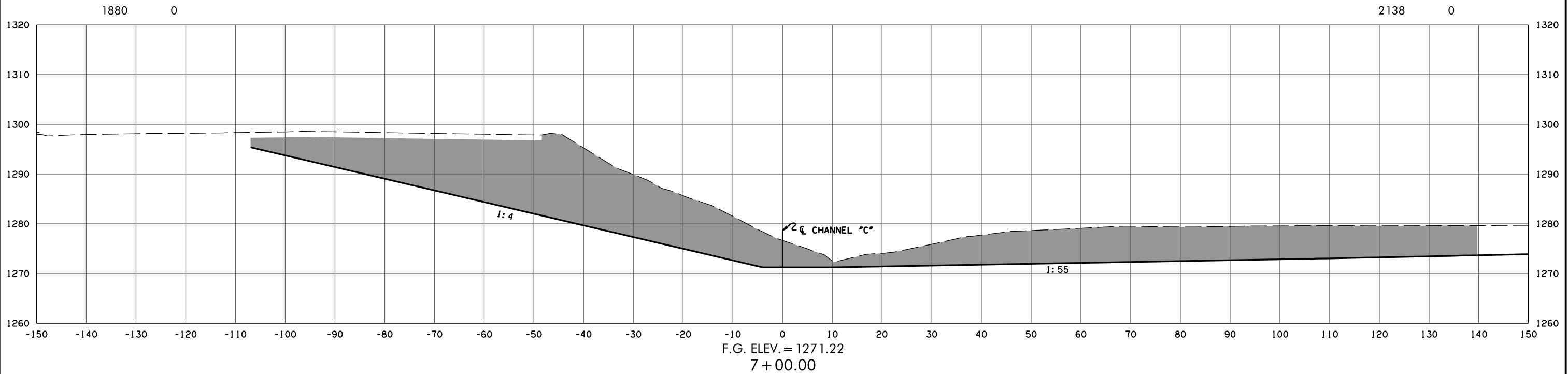

CHANNEL C

STATE JOB NO. 09032(08)
 OKLAHOMA COUNTY SHEET NO. X294

3/4/2024 3:59:56 PM
 H:\PROJECTS\2789_CrossRoads_Phase 4\Roadway\Drawings\Sections\0903208-XSEC.CHANNEL C.dgn

(CAUTION) THE LOCATION OF ALL UTILITIES AS SHOWN ARE APPROXIMATE. DUE TO RELOCATION'S PLANNED OR PRESENTLY UNDER CONSTRUCTION THERE ARE SOME UTILITIES THAT WILL BE RELOCATED AND NOT SHOWN ON THESE PLANS. THE CONTRACTOR SHALL BE RESPONSIBLE FOR ANY DAMAGE TO ALL UTILITIES.
 DEPTH & LOCATION OF EXISTING UTILITIES SHALL BE FIELD VERIFIED BY THE CONTRACTOR PRIOR TO CONSTRUCTION.

SEE DRAINAGE AREA MAP SHEETS FOR DRAINAGE SYMBOLOLOGY.

R/W & U/E PURCHASED UNDER JP 09032(05)

POB & ASSOCIATES, OKLAHOMA CITY, OK.
90% PLAN SUBMITTAL
 3/4/2024

AREA
 CUT FILL

VOLUME
 CUT FILL

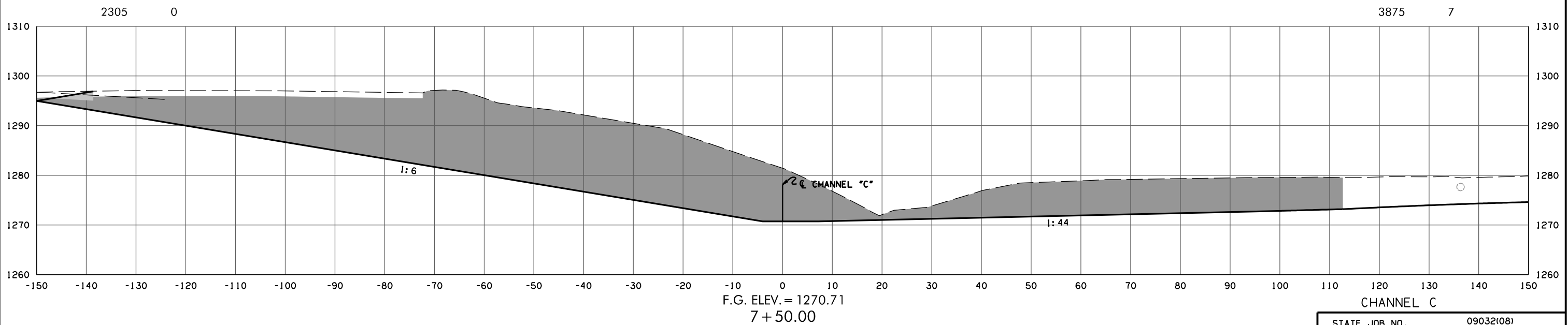
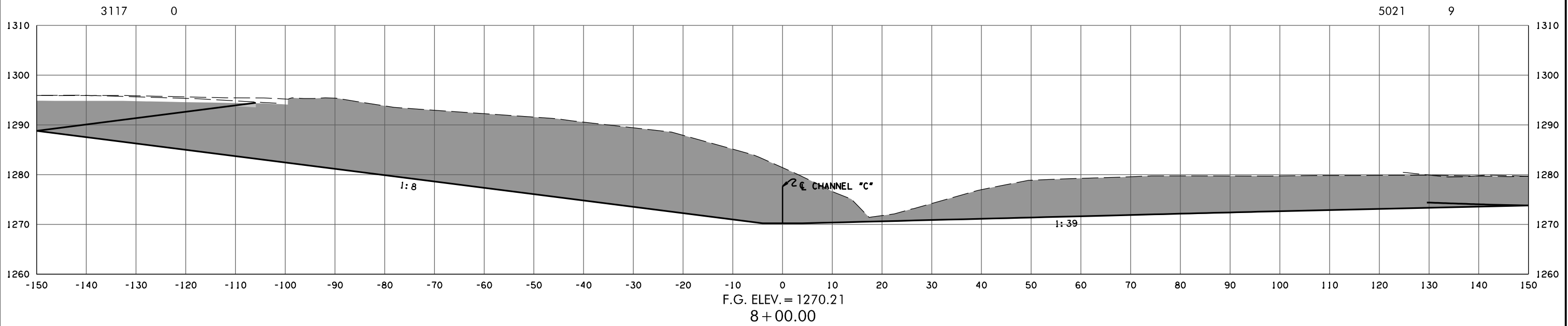

CHANNEL C
 STATE JOB NO. 09032(08)
 OKLAHOMA COUNTY SHEET NO. X295

3/4/2024 3:59:57 PM H:\PROJECTS\2789_Cr\osaRoads_Phase 4\Roadway\Drawings\Sections\0903208-XSEC.CHANNEL C.dgn

(CAUTION) THE LOCATION OF ALL UTILITIES AS SHOWN ARE APPROXIMATE. DUE TO RELOCATION'S PLANNED OR PRESENTLY UNDER CONSTRUCTION THERE ARE SOME UTILITIES THAT WILL BE RELOCATED AND NOT SHOWN ON THESE PLANS. THE CONTRACTOR SHALL BE RESPONSIBLE FOR ANY DAMAGE TO ALL UTILITIES.
 DEPTH & LOCATION OF EXISTING UTILITIES SHALL BE FIELD VERIFIED BY THE CONTRACTOR PRIOR TO CONSTRUCTION.

SEE DRAINAGE AREA MAP SHEETS FOR DRAINAGE SYMBOLOLOGY.

R/W & U/E PURCHASED UNDER JP 09032(05)

POB & ASSOCIATES, OKLAHOMA CITY, OK.
90% PLAN SUBMITTAL
 3/4/2024

AREA
 CUT FILL

VOLUME
 CUT FILL

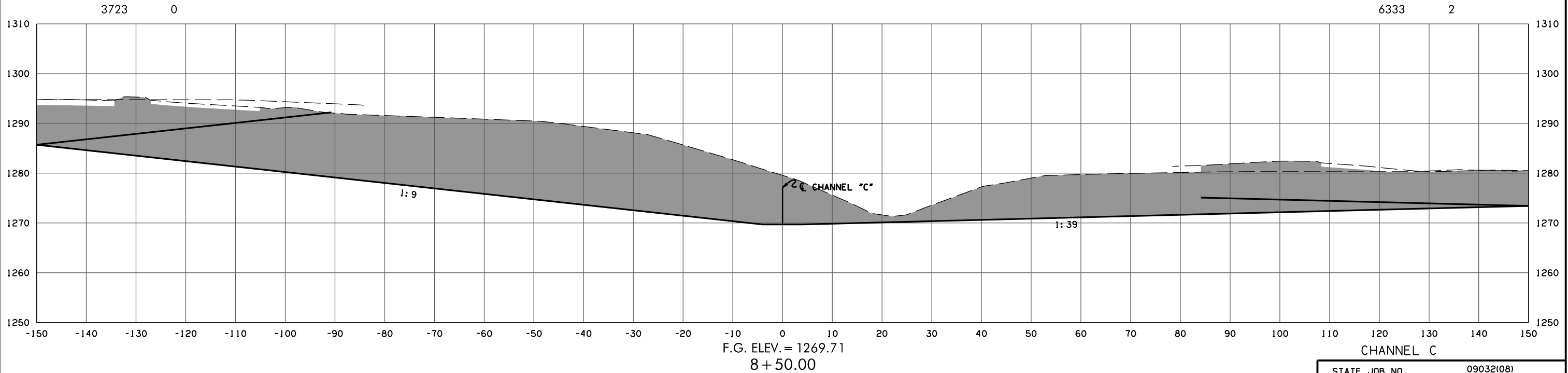
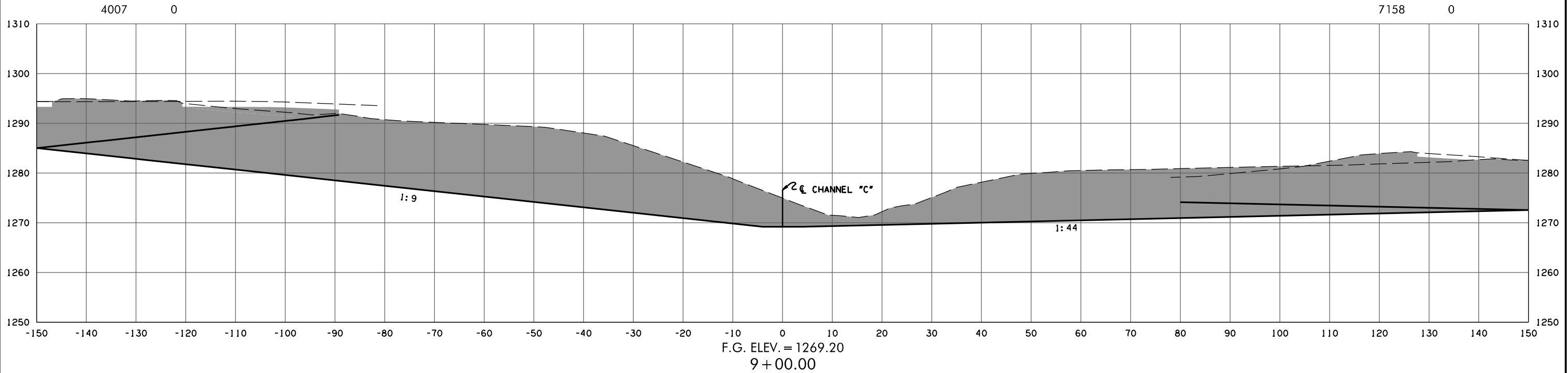

CHANNEL C
 STATE JOB NO. 09032(08)
 OKLAHOMA COUNTY SHEET NO. X296

3/4/2024 3:59:57 PM H:\PROJECTS\2789_CrossRoads_Phase 4\Roadway\Drawings\Sections\0903208-XSEC.CHANNEL C.dgn

(CAUTION) THE LOCATION OF ALL UTILITIES AS SHOWN ARE APPROXIMATE. DUE TO RELOCATION'S PLANNED OR PRESENTLY UNDER CONSTRUCTION THERE ARE SOME UTILITIES THAT WILL BE RELOCATED AND NOT SHOWN ON THESE PLANS. THE CONTRACTOR SHALL BE RESPONSIBLE FOR ANY DAMAGE TO ALL UTILITIES.
 DEPTH & LOCATION OF EXISTING UTILITIES SHALL BE FIELD VERIFIED BY THE CONTRACTOR PRIOR TO CONSTRUCTION.

SEE DRAINAGE AREA MAP SHEETS FOR DRAINAGE SYMBOLOLOGY.

R/W & U/E PURCHASED UNDER JP 09032(05)

POB & ASSOCIATES, OKLAHOMA CITY, OK.
90% PLAN
SUBMITTAL
 3/4/2024

AREA
 CUT FILL

VOLUME
 CUT FILL

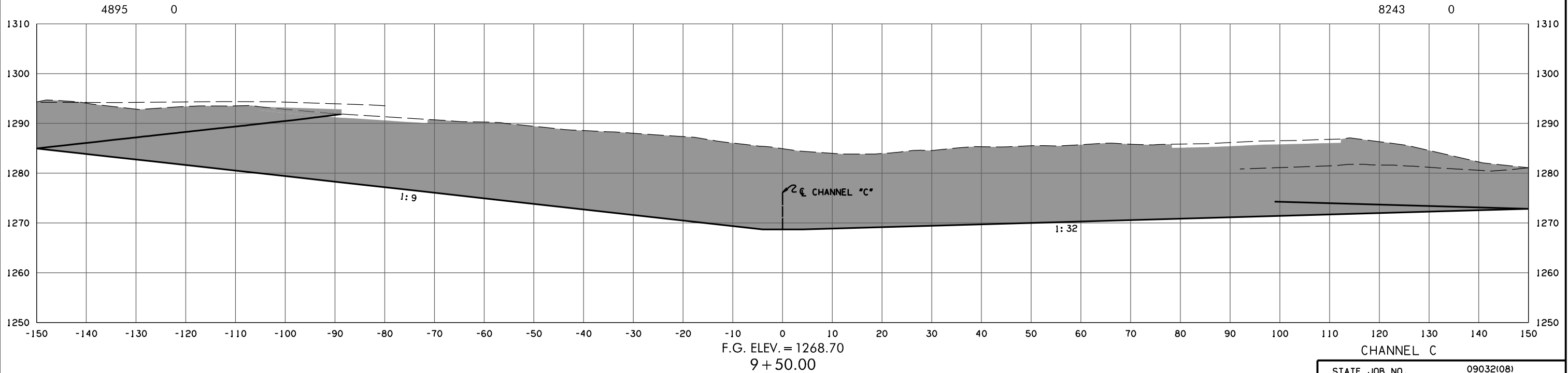
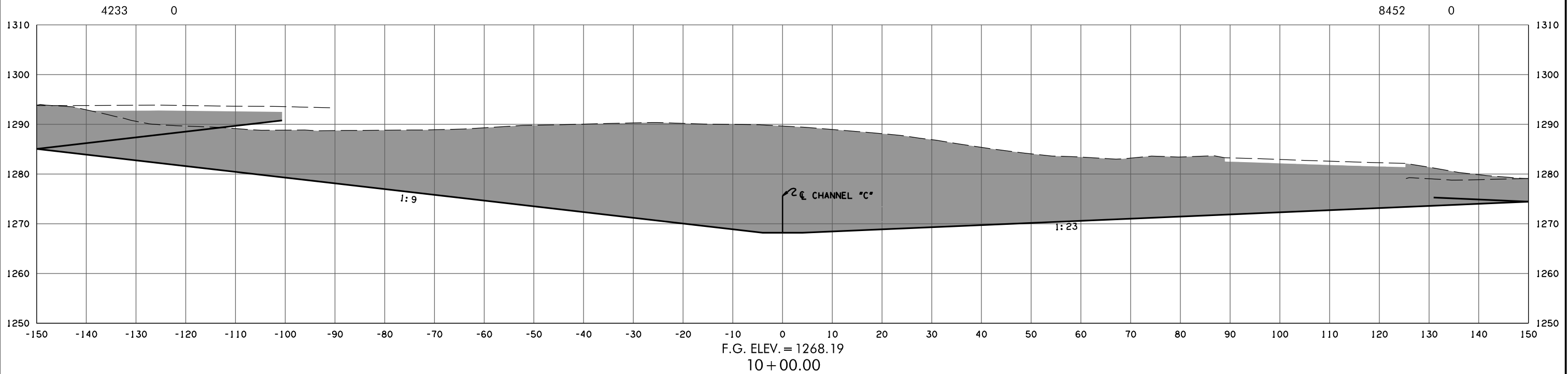

3/4/2024 3:59:58 PM H:\PROJECTS\2789_CrossRoads_Phase 4\Roadway\Drawings\Sections\0903208-XSEC.CHANNEL C.dgn

STATE JOB NO. 09032(08)
 OKLAHOMA COUNTY SHEET NO. X297

(CAUTION) THE LOCATION OF ALL UTILITIES AS SHOWN ARE APPROXIMATE. DUE TO RELOCATION'S PLANNED OR PRESENTLY UNDER CONSTRUCTION THERE ARE SOME UTILITIES THAT WILL BE RELOCATED AND NOT SHOWN ON THESE PLANS. THE CONTRACTOR SHALL BE RESPONSIBLE FOR ANY DAMAGE TO ALL UTILITIES.
 DEPTH & LOCATION OF EXISTING UTILITIES SHALL BE FIELD VERIFIED BY THE CONTRACTOR PRIOR TO CONSTRUCTION.

SEE DRAINAGE AREA MAP SHEETS FOR DRAINAGE SYMBOLOLOGY.

R/W & U/E PURCHASED UNDER JP 09032(05)

POB & ASSOCIATES, OKLAHOMA CITY, OK.
90% PLAN SUBMITTAL
 3/4/2024

AREA
 CUT FILL

VOLUME
 CUT FILL

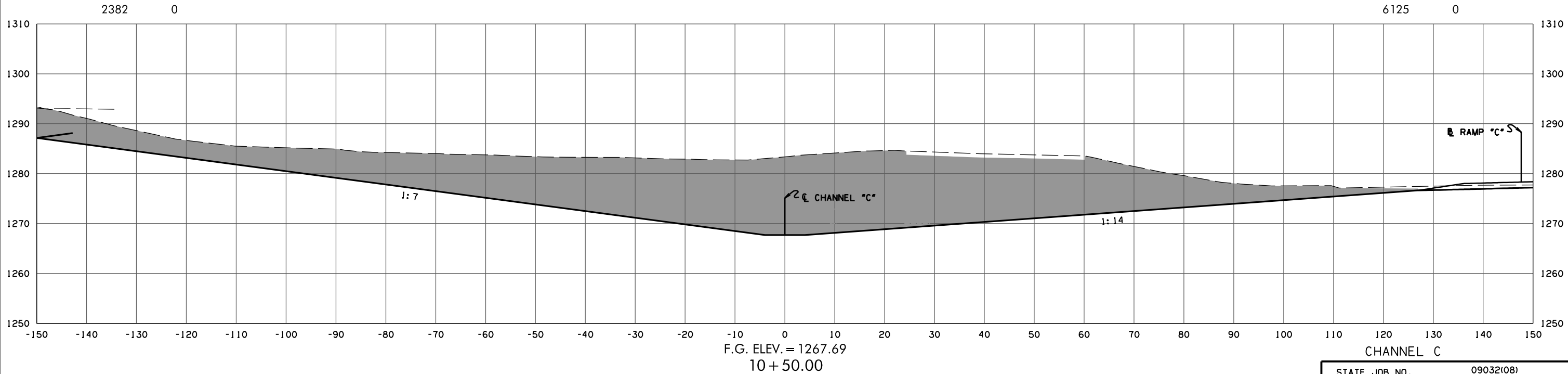
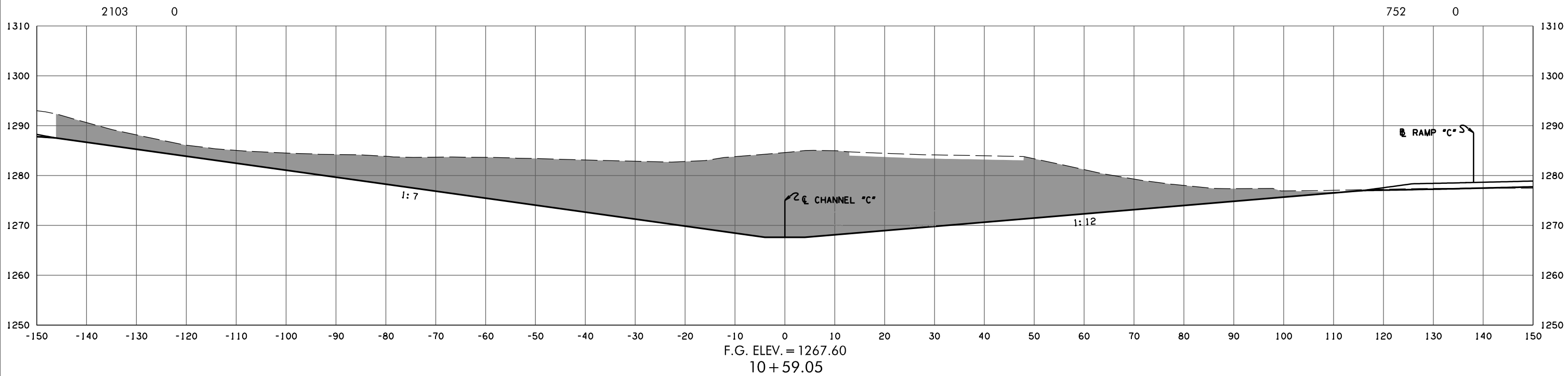

3/4/2024 3:59:59 PM H:\PROJECTS\2789_CrossRoads_Phase 4\Roadway\Drawings\Sections\0903208-XSEC.CHANNEL C.dgn

STATE JOB NO. 09032(08)
 OKLAHOMA COUNTY SHEET NO. X298

(CAUTION) THE LOCATION OF ALL UTILITIES AS SHOWN ARE APPROXIMATE. DUE TO RELOCATION'S PLANNED OR PRESENTLY UNDER CONSTRUCTION THERE ARE SOME UTILITIES THAT WILL BE RELOCATED AND NOT SHOWN ON THESE PLANS. THE CONTRACTOR SHALL BE RESPONSIBLE FOR ANY DAMAGE TO ALL UTILITIES.
 DEPTH & LOCATION OF EXISTING UTILITIES SHALL BE FIELD VERIFIED BY THE CONTRACTOR PRIOR TO CONSTRUCTION.

SEE DRAINAGE AREA MAP SHEETS FOR DRAINAGE SYMBOLOLOGY.

R/W & U/E PURCHASED UNDER JP 09032(05)

POB & ASSOCIATES, OKLAHOMA CITY, OK.
90% PLAN
SUBMITTAL
 3/4/2024

AREA
 CUT FILL

VOLUME
 CUT FILL

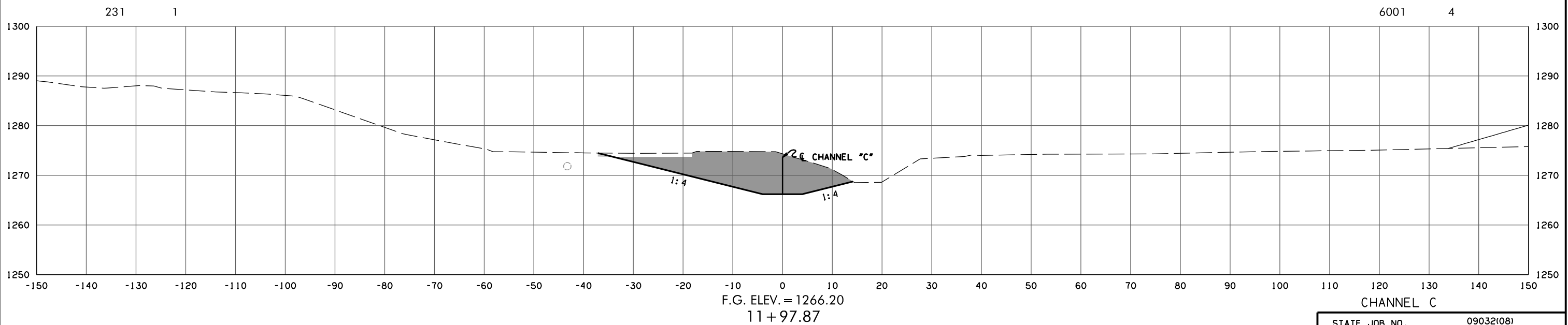
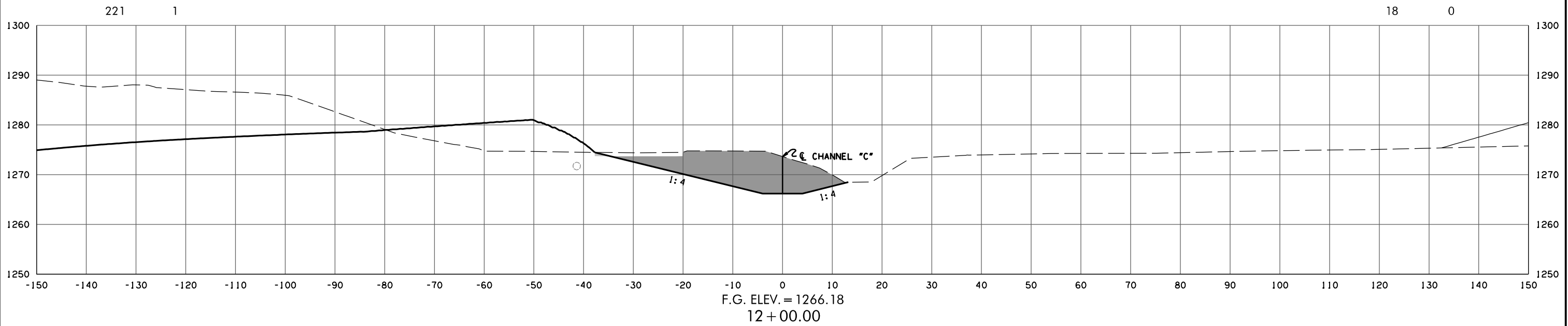

CHANNEL C

STATE JOB NO. 09032(08)
 OKLAHOMA COUNTY SHEET NO. X299

3/4/2024 3:59:59 PM H:\PROJECTS\2789_CrossRoads_Phase 4\Roadway\Drawings\Sections\0903208-XSEC.CHANNEL C.dgn

(CAUTION) THE LOCATION OF ALL UTILITIES AS SHOWN ARE APPROXIMATE. DUE TO RELOCATION'S PLANNED OR PRESENTLY UNDER CONSTRUCTION THERE ARE SOME UTILITIES THAT WILL BE RELOCATED AND NOT SHOWN ON THESE PLANS. THE CONTRACTOR SHALL BE RESPONSIBLE FOR ANY DAMAGE TO ALL UTILITIES.
 DEPTH & LOCATION OF EXISTING UTILITIES SHALL BE FIELD VERIFIED BY THE CONTRACTOR PRIOR TO CONSTRUCTION.

SEE DRAINAGE AREA MAP SHEETS FOR DRAINAGE SYMBOLOLOGY.

R/W & U/E PURCHASED UNDER JP 09032(05)

POB & ASSOCIATES, OKLAHOMA CITY, OK.
90% PLAN SUBMITTAL
 3/4/2024

AREA
 CUT FILL

VOLUME
 CUT FILL

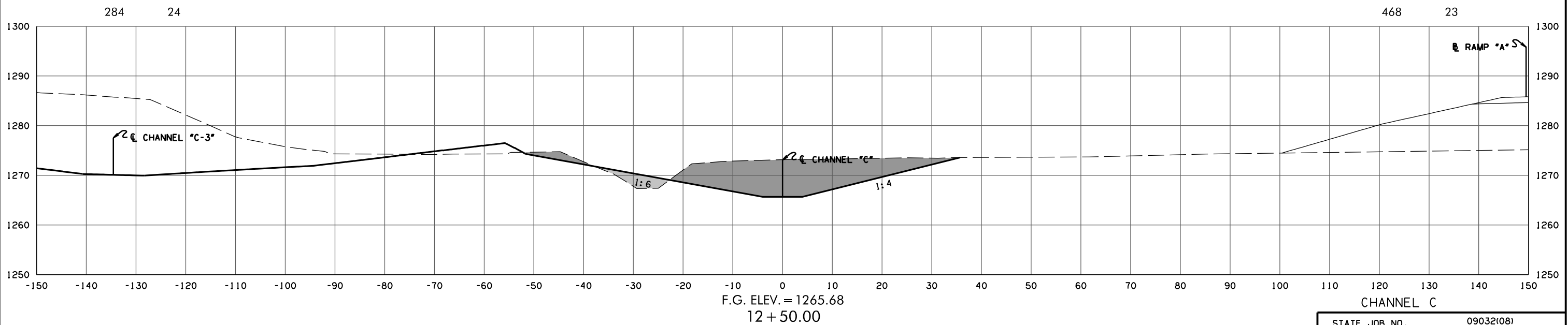
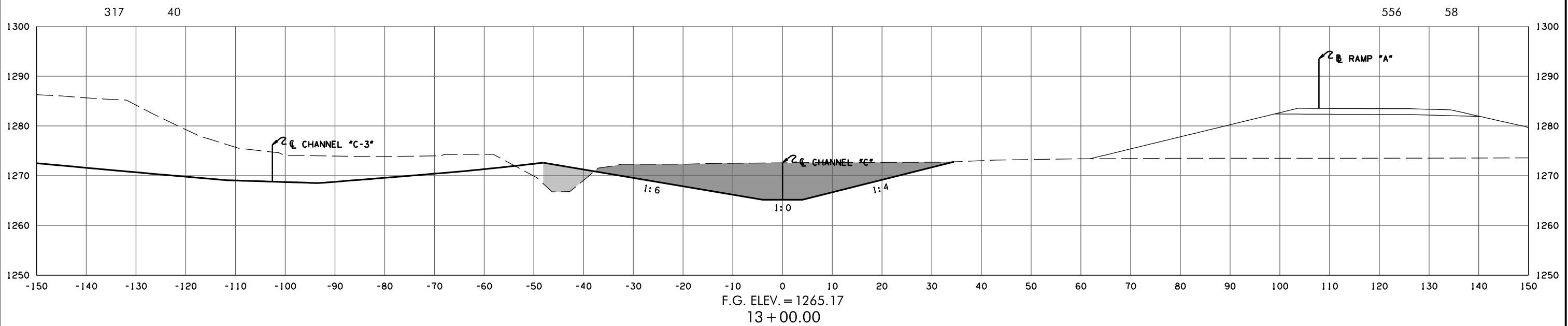

CHANNEL C
 STATE JOB NO. 09032(08)
 OKLAHOMA COUNTY SHEET NO. X300

3/4/2024 4:00:00 PM H:\PROJECTS\2789_CrossRoads_Phase 4\Roadway\Drawings\Sections\0903208-XSEC.CHANNEL C.dgn

(CAUTION) THE LOCATION OF ALL UTILITIES AS SHOWN ARE APPROXIMATE. DUE TO RELOCATION'S PLANNED OR PRESENTLY UNDER CONSTRUCTION THERE ARE SOME UTILITIES THAT WILL BE RELOCATED AND NOT SHOWN ON THESE PLANS. THE CONTRACTOR SHALL BE RESPONSIBLE FOR ANY DAMAGE TO ALL UTILITIES.
 DEPTH & LOCATION OF EXISTING UTILITIES SHALL BE FIELD VERIFIED BY THE CONTRACTOR PRIOR TO CONSTRUCTION.

SEE DRAINAGE AREA MAP SHEETS FOR DRAINAGE SYMBOLOLOGY.

R/W & U/E PURCHASED UNDER JP 09032(05)

POB & ASSOCIATES, OKLAHOMA CITY, OK.
90% PLAN
SUBMITTAL
 3/4/2024

AREA
 CUT FILL

VOLUME
 CUT FILL

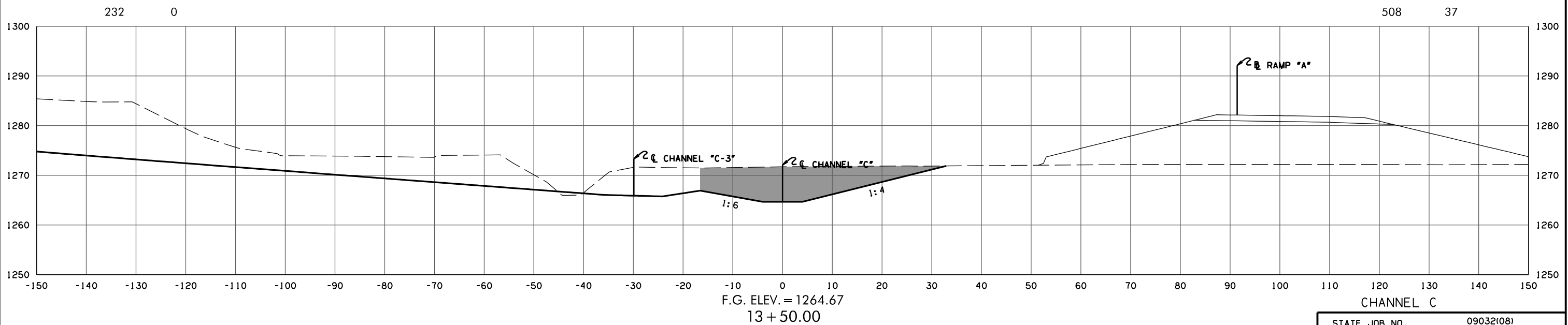
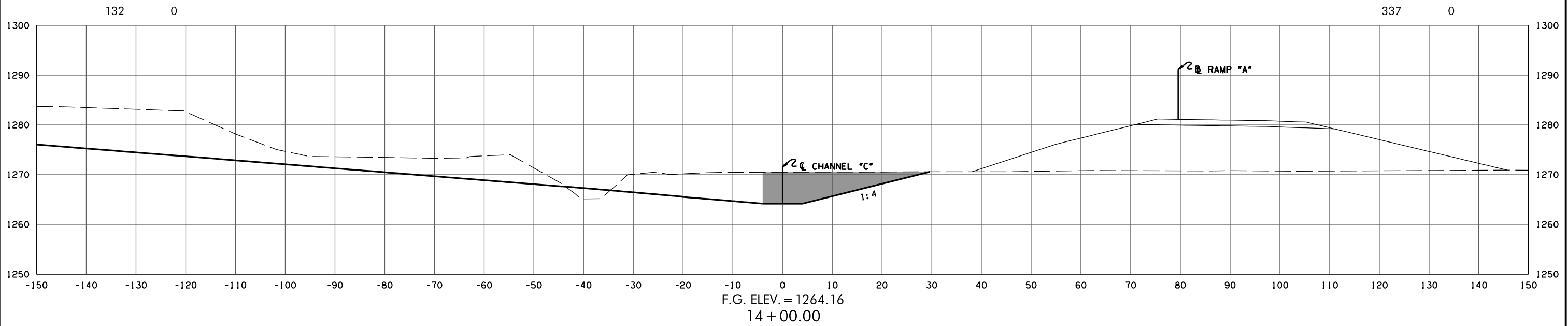

3/4/2024 4:00:01 PM H:\PROJECTS\2789_CrossRoads_Phase 4\Roadway\Drawings\Sections\0903208-XSEC.CHANNEL C.dgn

STATE JOB NO. 09032(08)
 OKLAHOMA COUNTY SHEET NO. X301

(CAUTION) THE LOCATION OF ALL UTILITIES AS SHOWN ARE APPROXIMATE. DUE TO RELOCATION'S PLANNED OR PRESENTLY UNDER CONSTRUCTION THERE ARE SOME UTILITIES THAT WILL BE RELOCATED AND NOT SHOWN ON THESE PLANS. THE CONTRACTOR SHALL BE RESPONSIBLE FOR ANY DAMAGE TO ALL UTILITIES.
 DEPTH & LOCATION OF EXISTING UTILITIES SHALL BE FIELD VERIFIED BY THE CONTRACTOR PRIOR TO CONSTRUCTION.

SEE DRAINAGE AREA MAP SHEETS FOR DRAINAGE SYMBOLOLOGY.

R/W & U/E PURCHASED UNDER JP 09032(05)

POB & ASSOCIATES, OKLAHOMA CITY, OK.
90% PLAN
SUBMITTAL
 3/4/2024

AREA
 CUT FILL

VOLUME
 CUT FILL

3/4/2024 4:00:01 PM H:\PROJECTS\2789_CrossRoads_Phase 4\Roadway\Drawings\Sections\0903208-XSEC.CHANNEL C.dgn

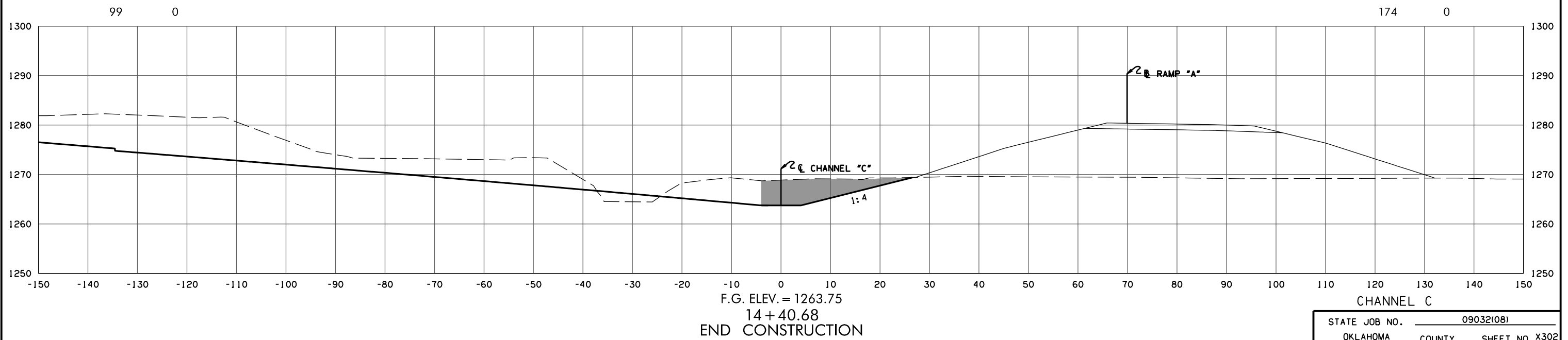

STATE JOB NO. 09032(08)
 OKLAHOMA COUNTY SHEET NO. X302

(CAUTION) THE LOCATION OF ALL UTILITIES AS SHOWN ARE APPROXIMATE. DUE TO RELOCATION'S PLANNED OR PRESENTLY UNDER CONSTRUCTION THERE ARE SOME UTILITIES THAT WILL BE RELOCATED AND NOT SHOWN ON THESE PLANS. THE CONTRACTOR SHALL BE RESPONSIBLE FOR ANY DAMAGE TO ALL UTILITIES.

DEPTH & LOCATION OF EXISTING UTILITIES SHALL BE FIELD VERIFIED BY THE CONTRACTOR PRIOR TO CONSTRUCTION.

SEE DRAINAGE AREA MAP SHEETS FOR DRAINAGE SYMBOLOLOGY.

R/W & U/E PURCHASED UNDER JP 09032(05)

POB & ASSOCIATES, OKLAHOMA CITY, OK.

**90% PLAN
SUBMITTAL**

3/4/2024

AREA
CUT FILL

VOLUME
CUT FILL

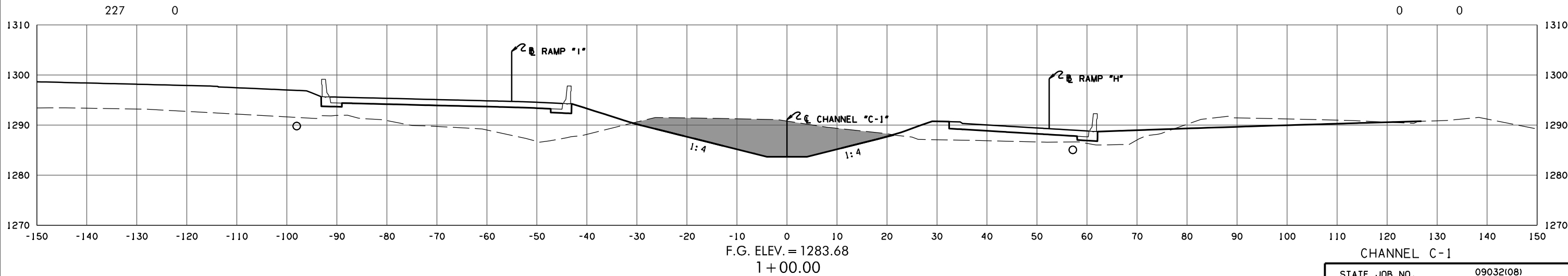
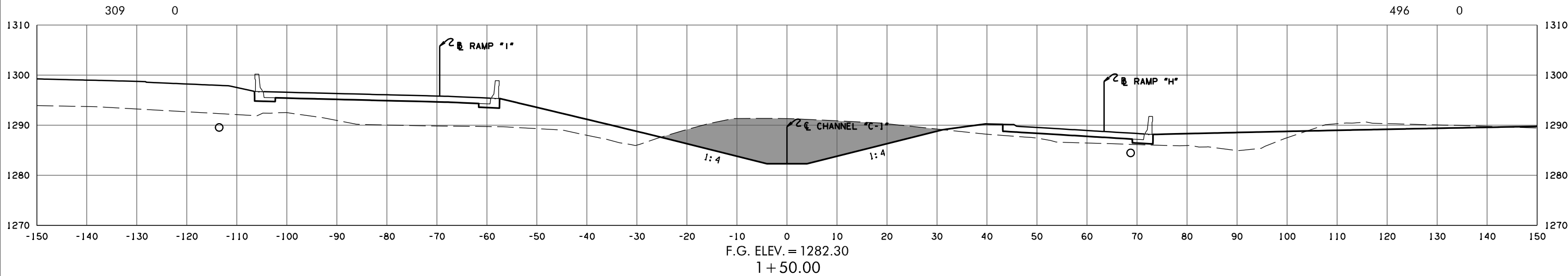
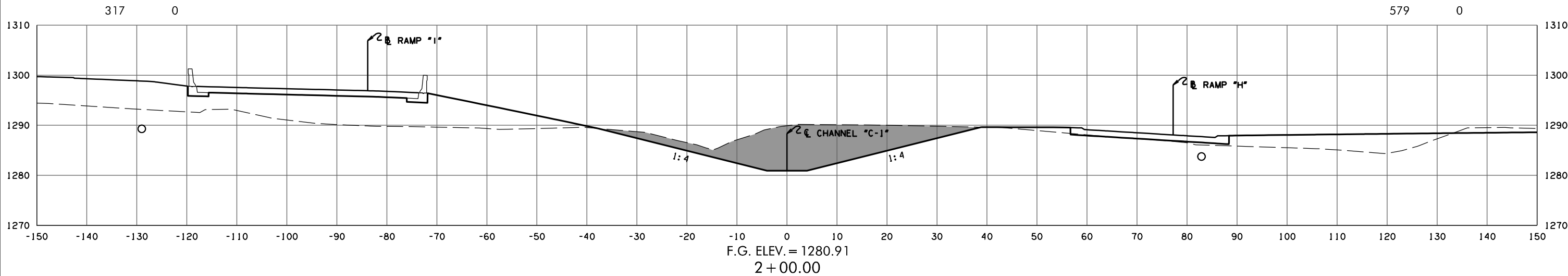

CHANNEL C-1
STATE JOB NO. 09032(08)
OKLAHOMA COUNTY SHEET NO. X303

3/4/2024 4:00:02 PM H:\PROJECTS\2789_CrossRoads_Phase 4\Roadway\Drawings\Sections\0903208-XSEC.CHANNEL C-1.dgn

(CAUTION) THE LOCATION OF ALL UTILITIES AS SHOWN ARE APPROXIMATE. DUE TO RELOCATION'S PLANNED OR PRESENTLY UNDER CONSTRUCTION THERE ARE SOME UTILITIES THAT WILL BE RELOCATED AND NOT SHOWN ON THESE PLANS. THE CONTRACTOR SHALL BE RESPONSIBLE FOR ANY DAMAGE TO ALL UTILITIES.
 DEPTH & LOCATION OF EXISTING UTILITIES SHALL BE FIELD VERIFIED BY THE CONTRACTOR PRIOR TO CONSTRUCTION.

SEE DRAINAGE AREA MAP SHEETS FOR DRAINAGE SYMBOLOLOGY.

R/W & U/E PURCHASED UNDER JP 09032(05)

POB & ASSOCIATES, OKLAHOMA CITY, OK.

**90% PLAN
SUBMITTAL**

3/4/2024

AREA
CUT FILL

VOLUME
CUT FILL

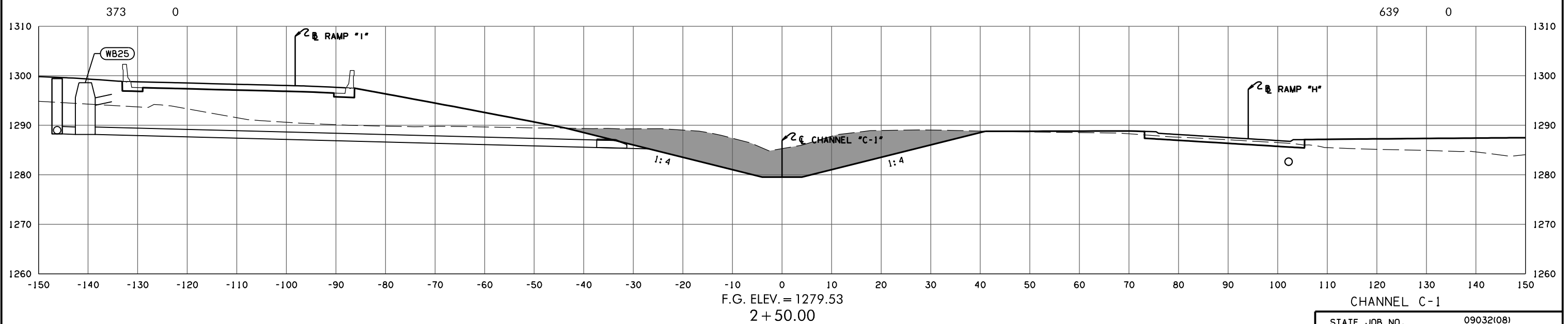
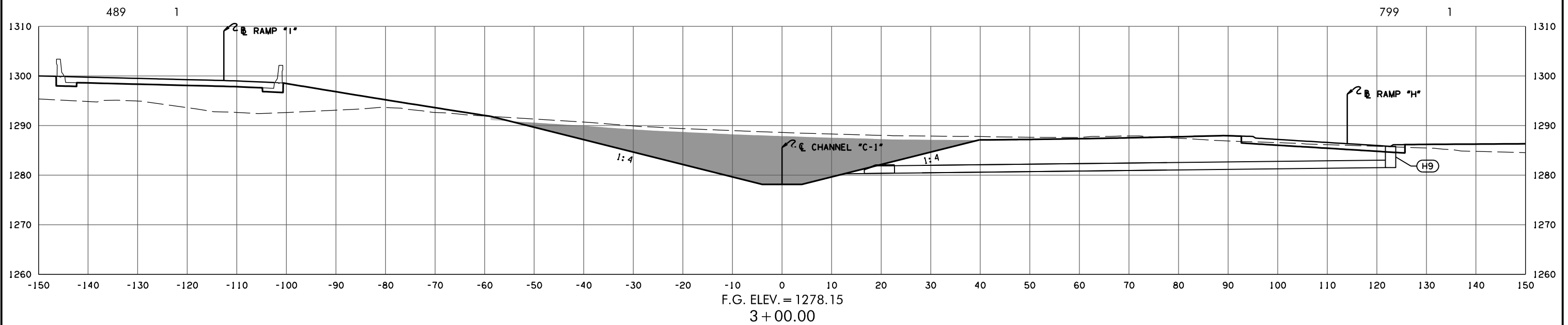

CHANNEL C-1

STATE JOB NO. 09032(08)
 OKLAHOMA COUNTY SHEET NO. X304

3/4/2024 4:00:02 PM H:\PROJECTS\2789_CrossRoads_Phase 4\Roadway\Drawings\Sections\0903208-XSEC.CHANNEL C-1.dgn

(CAUTION) THE LOCATION OF ALL UTILITIES AS SHOWN ARE APPROXIMATE. DUE TO RELOCATION'S PLANNED OR PRESENTLY UNDER CONSTRUCTION THERE ARE SOME UTILITIES THAT WILL BE RELOCATED AND NOT SHOWN ON THESE PLANS. THE CONTRACTOR SHALL BE RESPONSIBLE FOR ANY DAMAGE TO ALL UTILITIES.
 DEPTH & LOCATION OF EXISTING UTILITIES SHALL BE FIELD VERIFIED BY THE CONTRACTOR PRIOR TO CONSTRUCTION.

SEE DRAINAGE AREA MAP SHEETS FOR DRAINAGE SYMBOLOLOGY.

R/W & U/E PURCHASED UNDER JP 09032(05)

POB & ASSOCIATES, OKLAHOMA CITY, OK.
90% PLAN SUBMITTAL
 3/4/2024

AREA
 CUT FILL

VOLUME
 CUT FILL

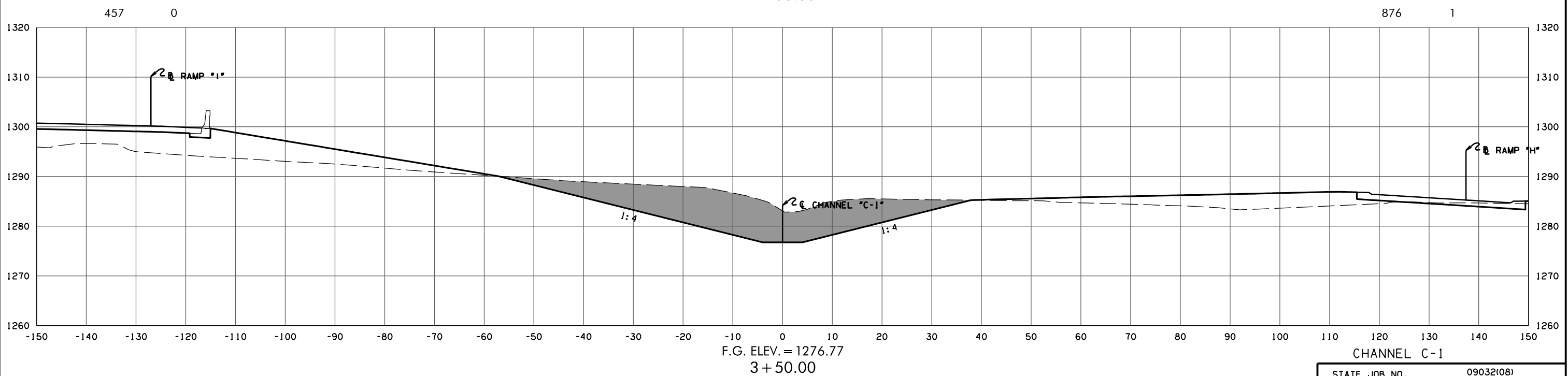
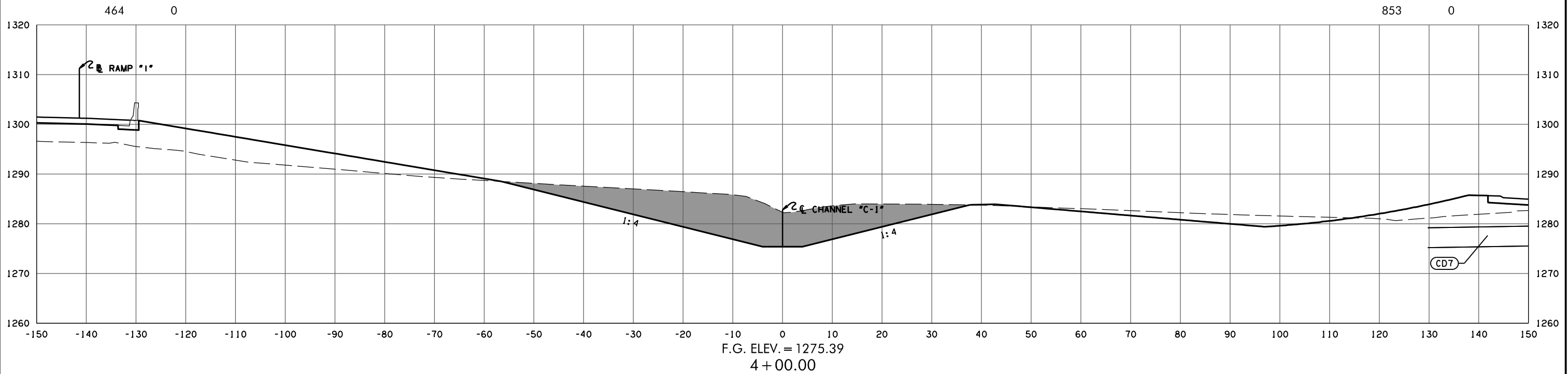

CHANNEL C-1

STATE JOB NO. 09032(08)
 OKLAHOMA COUNTY SHEET NO. X305

3/4/2024 4:00:03 PM H:\PROJECTS\2789_CrossRoads_Phase 4\Roadway\Drawings\Sections\0903208-XSEC.CHANNEL C-1.dgn

(CAUTION) THE LOCATION OF ALL UTILITIES AS SHOWN ARE APPROXIMATE. DUE TO RELOCATION'S PLANNED OR PRESENTLY UNDER CONSTRUCTION THERE ARE SOME UTILITIES THAT WILL BE RELOCATED AND NOT SHOWN ON THESE PLANS. THE CONTRACTOR SHALL BE RESPONSIBLE FOR ANY DAMAGE TO ALL UTILITIES.
 DEPTH & LOCATION OF EXISTING UTILITIES SHALL BE FIELD VERIFIED BY THE CONTRACTOR PRIOR TO CONSTRUCTION.

SEE DRAINAGE AREA MAP SHEETS FOR DRAINAGE SYMBOLOLOGY.

R/W & U/E PURCHASED UNDER JP 09032(05)

POB & ASSOCIATES, OKLAHOMA CITY, OK.
90% PLAN
SUBMITTAL
 3/4/2024

AREA
 CUT FILL

VOLUME
 CUT FILL

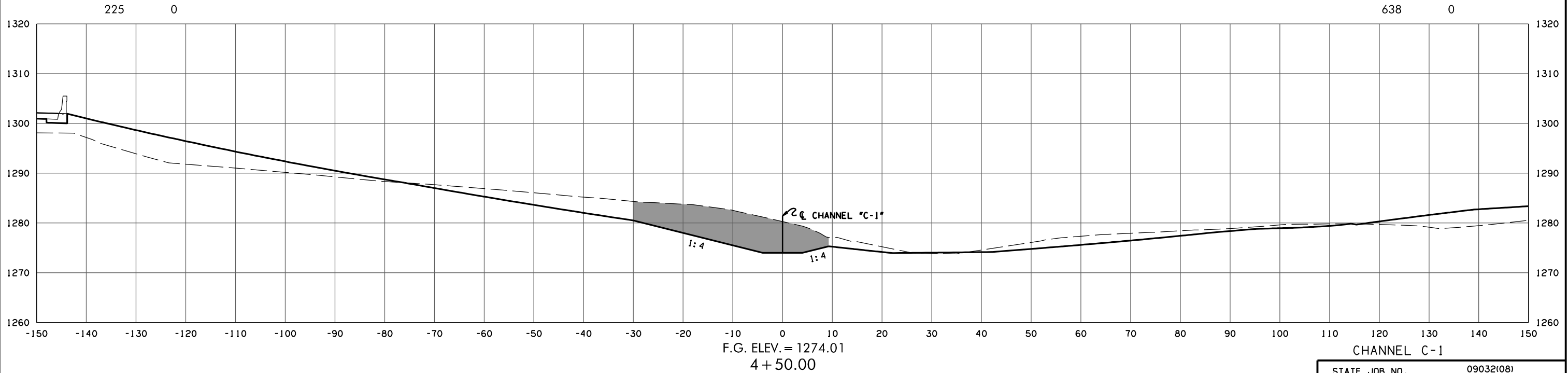
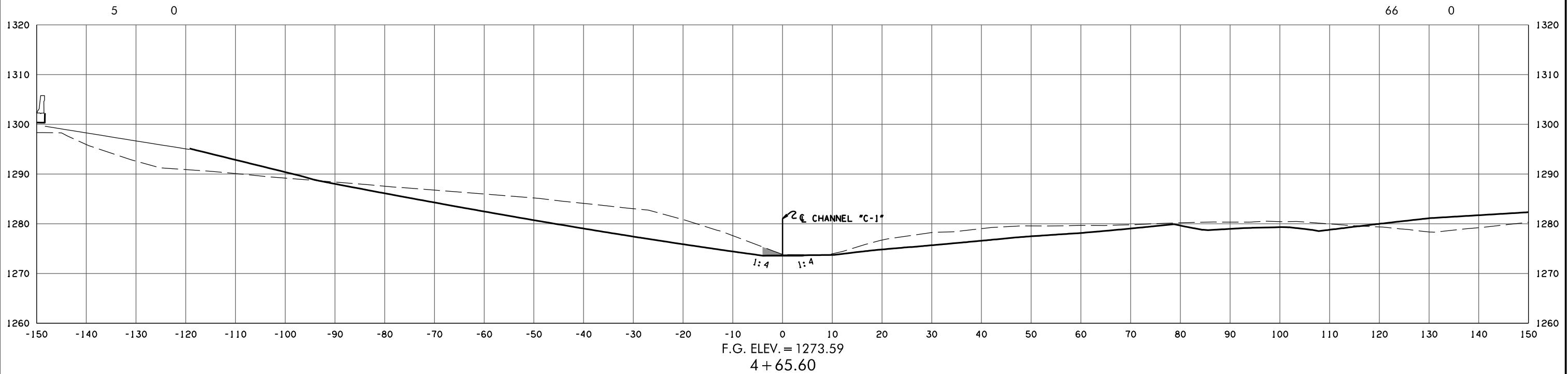

CHANNEL C-1
 STATE JOB NO. 09032(08)
 OKLAHOMA COUNTY SHEET NO. X306

3/4/2024 4:00:03 PM
 H:\PROJECTS\2789_CrossRoads_Phase 4\Roadway\Drawings\Sections\0903208-XSEC.CHANNEL C-1.dgn

(CAUTION) THE LOCATION OF ALL UTILITIES AS SHOWN ARE APPROXIMATE. DUE TO RELOCATION'S PLANNED OR PRESENTLY UNDER CONSTRUCTION THERE ARE SOME UTILITIES THAT WILL BE RELOCATED AND NOT SHOWN ON THESE PLANS. THE CONTRACTOR SHALL BE RESPONSIBLE FOR ANY DAMAGE TO ALL UTILITIES.
 DEPTH & LOCATION OF EXISTING UTILITIES SHALL BE FIELD VERIFIED BY THE CONTRACTOR PRIOR TO CONSTRUCTION.

SEE DRAINAGE AREA MAP SHEETS FOR DRAINAGE SYMBOLOLOGY.

R/W & U/E PURCHASED UNDER JP 09032(05)

POB & ASSOCIATES, OKLAHOMA CITY, OK.
90% PLAN
SUBMITTAL
 3/4/2024

AREA
 CUT FILL

VOLUME
 CUT FILL

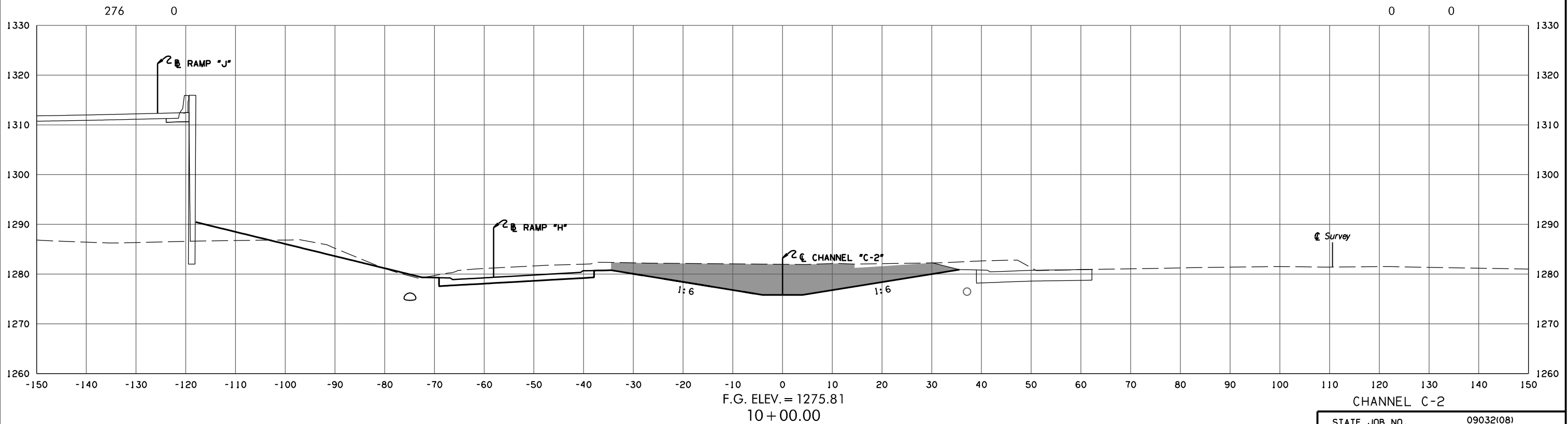
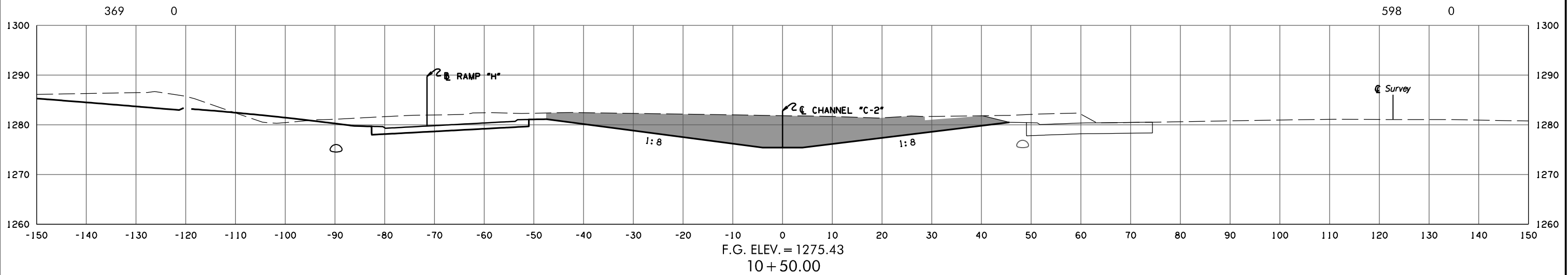

CHANNEL C-2

STATE JOB NO. 09032(08)
 OKLAHOMA COUNTY SHEET NO. X307

3/4/2024 4:00:04 PM H:\PROJECTS\2789_CrossRoads_Phase 4\Roadway\Drawings\Sections\0903208-XSEC.CHANNEL C-2.dgn

(CAUTION) THE LOCATION OF ALL UTILITIES AS SHOWN ARE APPROXIMATE. DUE TO RELOCATION'S PLANNED OR PRESENTLY UNDER CONSTRUCTION THERE ARE SOME UTILITIES THAT WILL BE RELOCATED AND NOT SHOWN ON THESE PLANS. THE CONTRACTOR SHALL BE RESPONSIBLE FOR ANY DAMAGE TO ALL UTILITIES.

DEPTH & LOCATION OF EXISTING UTILITIES SHALL BE FIELD VERIFIED BY THE CONTRACTOR PRIOR TO CONSTRUCTION.

SEE DRAINAGE AREA MAP SHEETS FOR DRAINAGE SYMBOLOLOGY.

R/W & U/E PURCHASED UNDER JP 09032(05)

POB & ASSOCIATES, OKLAHOMA CITY, OK.

**90% PLAN
SUBMITTAL**

3/4/2024

AREA
CUT FILL

VOLUME
CUT FILL

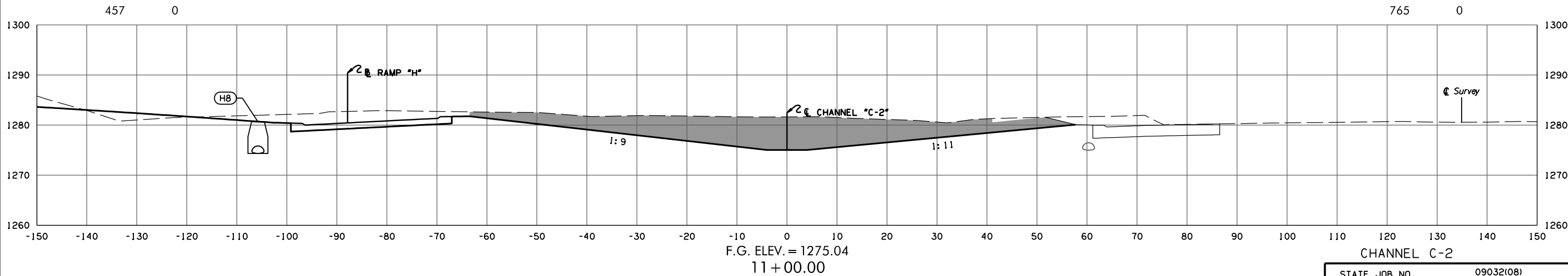
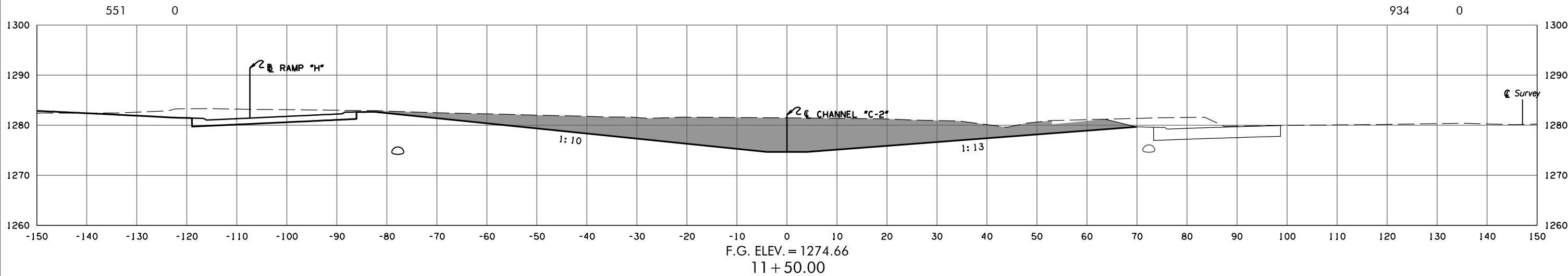
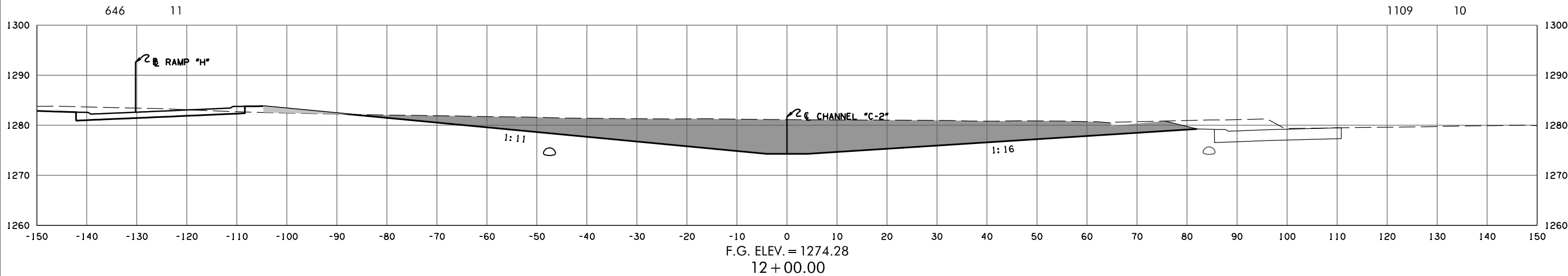

CHANNEL C-2

STATE JOB NO. 09032(08)
OKLAHOMA COUNTY SHEET NO. X308

3/4/2024 4:00:04 PM H:\PROJECTS\2789_CrossRoads_Phase 4\Roadway\Drawings\Sections\0903208-XSEC.CHANNEL C-2.dgn

(CAUTION) THE LOCATION OF ALL UTILITIES AS SHOWN ARE APPROXIMATE. DUE TO RELOCATION'S PLANNED OR PRESENTLY UNDER CONSTRUCTION THERE ARE SOME UTILITIES THAT WILL BE RELOCATED AND NOT SHOWN ON THESE PLANS. THE CONTRACTOR SHALL BE RESPONSIBLE FOR ANY DAMAGE TO ALL UTILITIES.
 DEPTH & LOCATION OF EXISTING UTILITIES SHALL BE FIELD VERIFIED BY THE CONTRACTOR PRIOR TO CONSTRUCTION.

SEE DRAINAGE AREA MAP SHEETS FOR DRAINAGE SYMBOLOLOGY.

R/W & U/E PURCHASED UNDER JP 09032(05)

POB & ASSOCIATES, OKLAHOMA CITY, OK.

**90% PLAN
SUBMITTAL**

3/4/2024

AREA
CUT FILL

VOLUME
CUT FILL

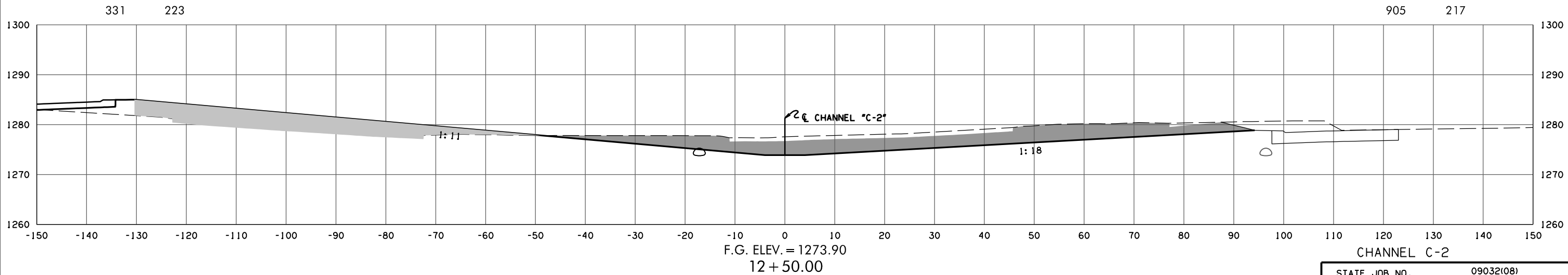
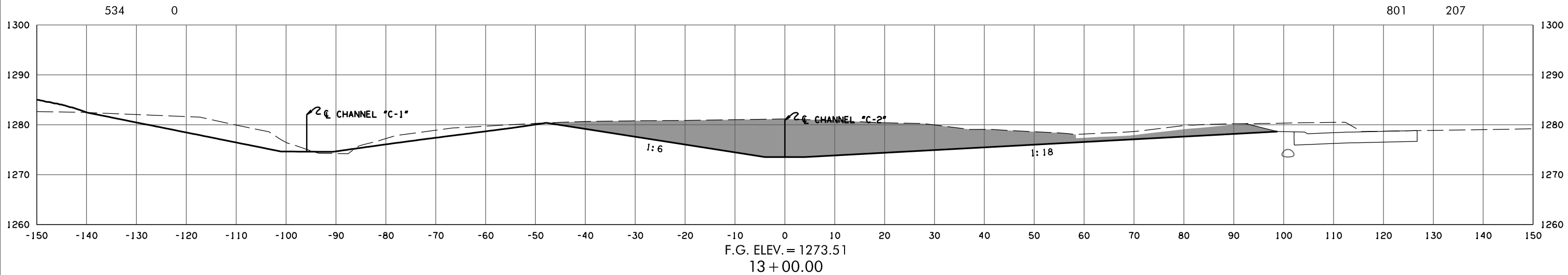
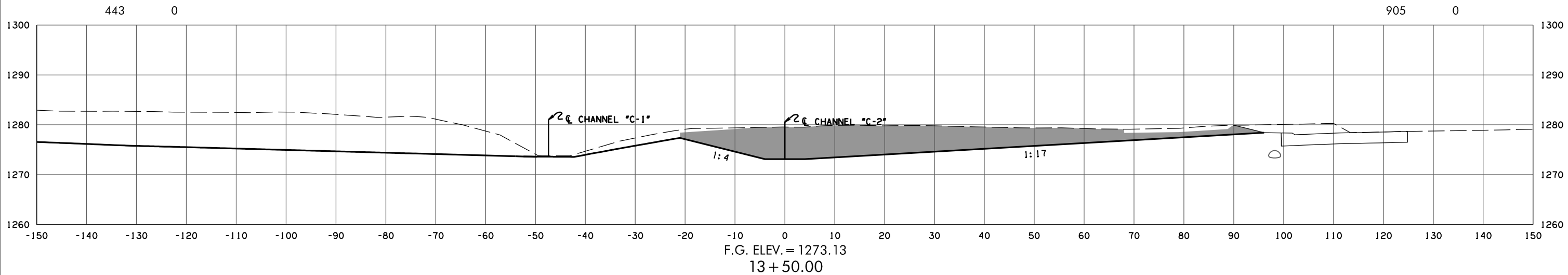

CHANNEL C-2

STATE JOB NO. 09032(08)
 OKLAHOMA COUNTY SHEET NO. X309

3/4/2024 4:00:05 PM H:\PROJECTS\2789_CrossRoads_Phase 4\Roadway\Drawings\Sections\0903208-XSEC.CHANNEL C-2.dgn

(CAUTION) THE LOCATION OF ALL UTILITIES AS SHOWN ARE APPROXIMATE. DUE TO RELOCATION'S PLANNED OR PRESENTLY UNDER CONSTRUCTION THERE ARE SOME UTILITIES THAT WILL BE RELOCATED AND NOT SHOWN ON THESE PLANS. THE CONTRACTOR SHALL BE RESPONSIBLE FOR ANY DAMAGE TO ALL UTILITIES.
 DEPTH & LOCATION OF EXISTING UTILITIES SHALL BE FIELD VERIFIED BY THE CONTRACTOR PRIOR TO CONSTRUCTION.

SEE DRAINAGE AREA MAP SHEETS FOR DRAINAGE SYMBOLOLOGY.

R/W & U/E PURCHASED UNDER JP 09032(05)

POB & ASSOCIATES, OKLAHOMA CITY, OK.
90% PLAN
SUBMITTAL
 3/4/2024

AREA
 CUT FILL

VOLUME
 CUT FILL

3/4/2024 4:00:05 PM
 H:\PROJECTS\2789_CrossRoads_Phase 4\Roadway\Drawings\Sections\0903208-XSEC.CHANNEL C-2.dgn

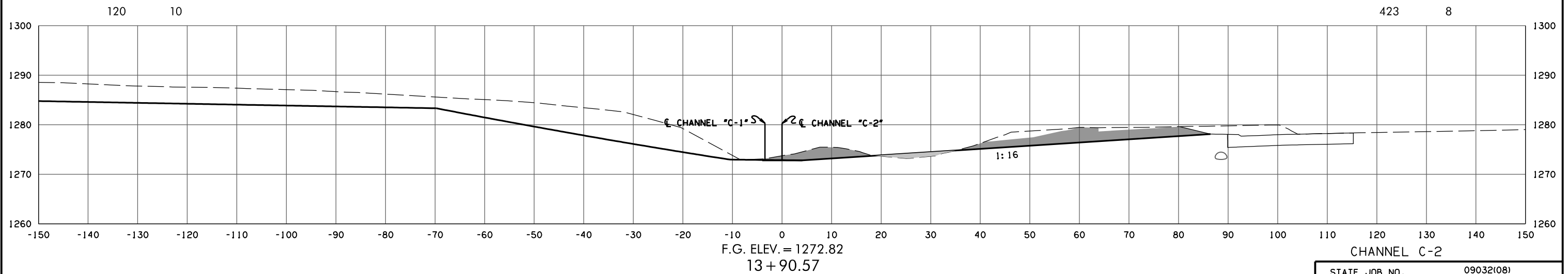

STATE JOB NO. 09032(08)
 OKLAHOMA COUNTY SHEET NO. X310

(CAUTION) THE LOCATION OF ALL UTILITIES AS SHOWN ARE APPROXIMATE. DUE TO RELOCATION'S PLANNED OR PRESENTLY UNDER CONSTRUCTION THERE ARE SOME UTILITIES THAT WILL BE RELOCATED AND NOT SHOWN ON THESE PLANS. THE CONTRACTOR SHALL BE RESPONSIBLE FOR ANY DAMAGE TO ALL UTILITIES.

SEE DRAINAGE AREA MAP SHEETS FOR DRAINAGE SYMBOLOLOGY.

R/W & U/E PURCHASED UNDER JP 09032(05)

POB & ASSOCIATES, OKLAHOMA CITY, OK.

**90% PLAN
SUBMITTAL**

3/4/2024

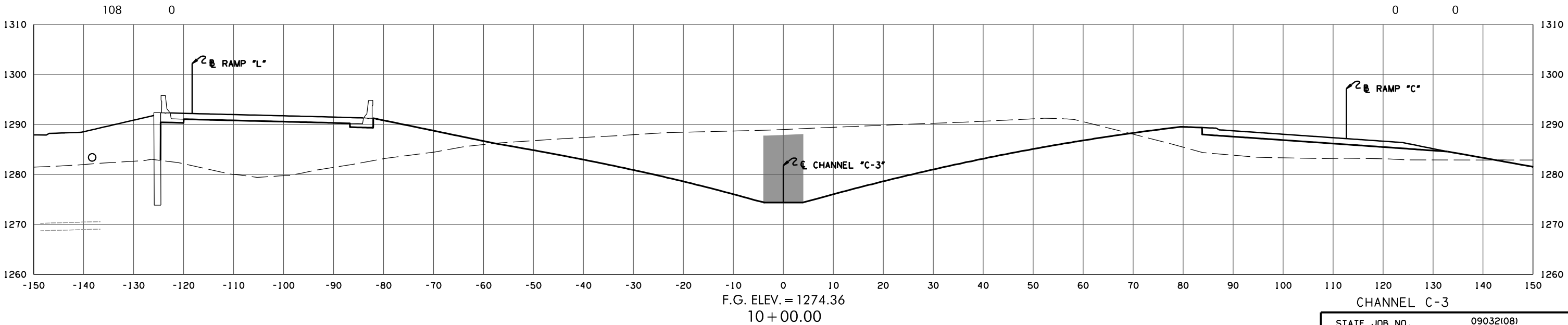
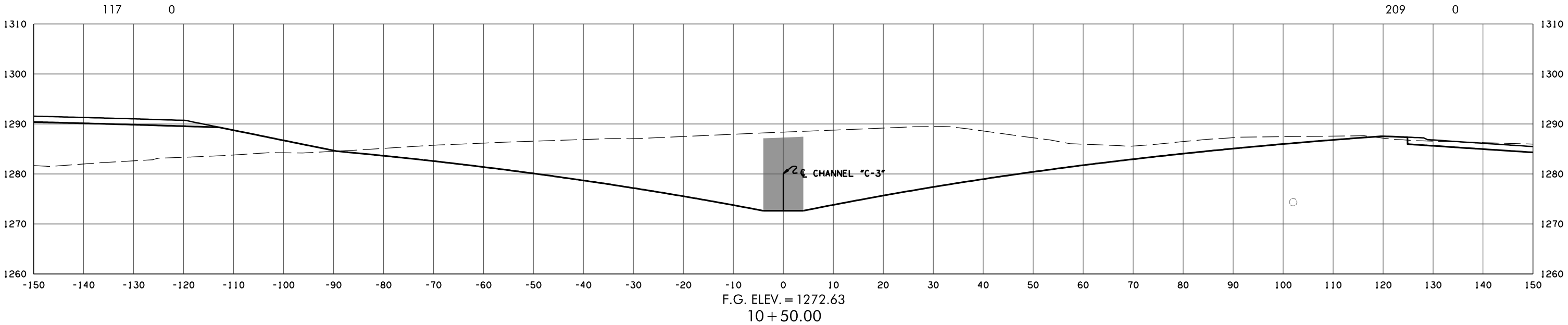
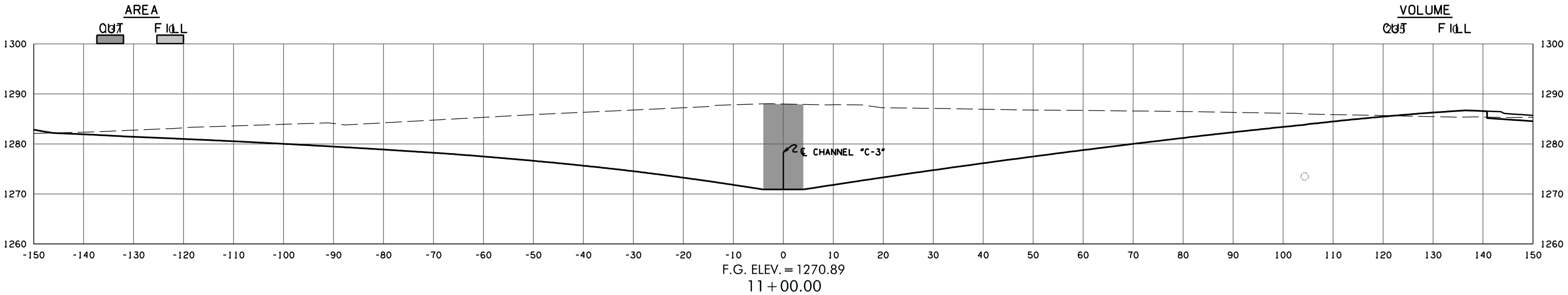

CHANNEL C-3	
STATE JOB NO.	09032(08)
OKLAHOMA COUNTY	SHEET NO. X311

3/4/2024 4:00:06 PM H:\PROJECTS\2789_CrossRoads_Phase 4\Roadway\Drawings\Sections\0903208-XSEC.CHANNEL C-3.dgn

(CAUTION) THE LOCATION OF ALL UTILITIES AS SHOWN ARE APPROXIMATE. DUE TO RELOCATION'S PLANNED OR PRESENTLY UNDER CONSTRUCTION THERE ARE SOME UTILITIES THAT WILL BE RELOCATED AND NOT SHOWN ON THESE PLANS. THE CONTRACTOR SHALL BE RESPONSIBLE FOR ANY DAMAGE TO ALL UTILITIES.
 DEPTH & LOCATION OF EXISTING UTILITIES SHALL BE FIELD VERIFIED BY THE CONTRACTOR PRIOR TO CONSTRUCTION.

SEE DRAINAGE AREA MAP SHEETS FOR DRAINAGE SYMBOLOLOGY.

R/W & U/E PURCHASED UNDER JP 09032(05)

POB & ASSOCIATES, OKLAHOMA CITY, OK.
90% PLAN
SUBMITTAL
 3/4/2024

AREA
 CUT FILL

VOLUME
 CUT FILL

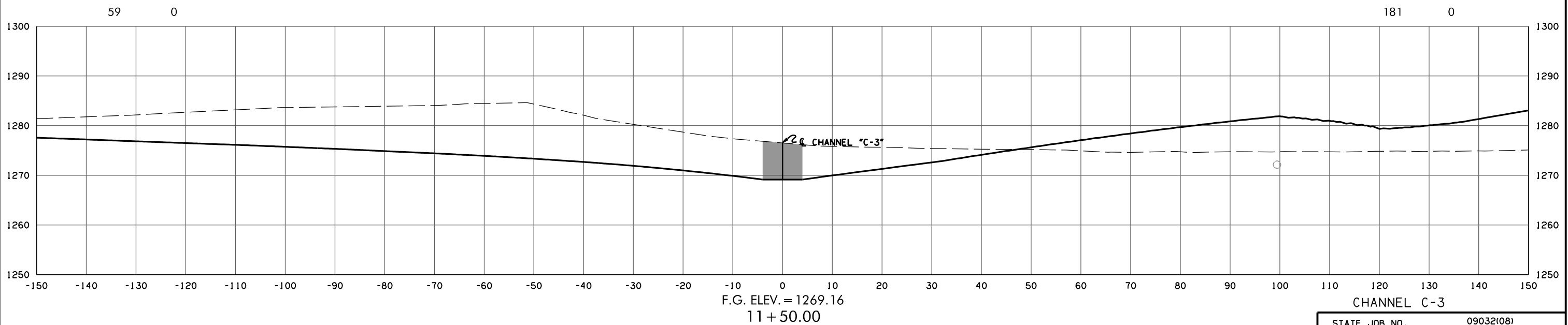
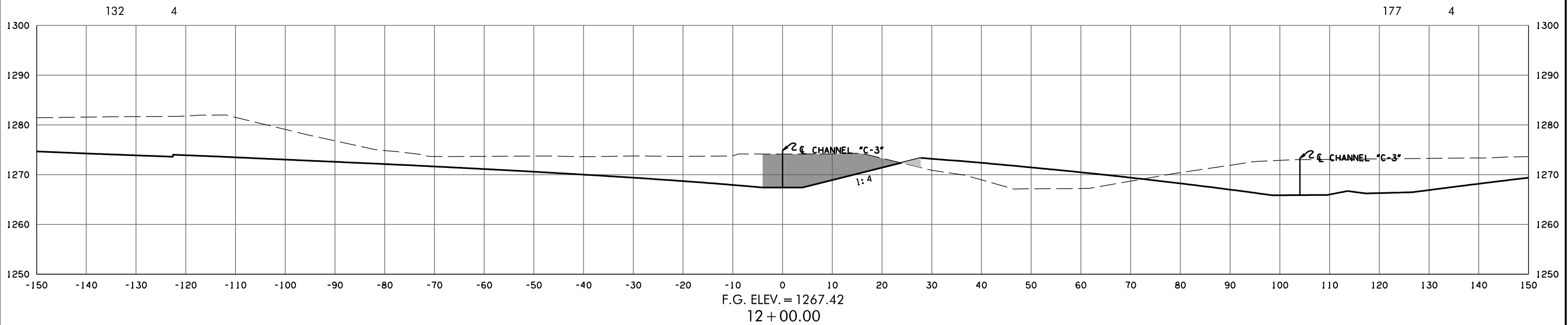

CHANNEL C-3

STATE JOB NO. 09032(08)
 OKLAHOMA COUNTY SHEET NO. X312

3/4/2024 4:00:06 PM H:\PROJECTS\2789_CrossRoads_Phase 4\Roadway\Drawings\Sections\0903208-XSEC.CHANNEL C-3.dgn

(CAUTION) THE LOCATION OF ALL UTILITIES AS SHOWN ARE APPROXIMATE. DUE TO RELOCATION'S PLANNED OR PRESENTLY UNDER CONSTRUCTION THERE ARE SOME UTILITIES THAT WILL BE RELOCATED AND NOT SHOWN ON THESE PLANS. THE CONTRACTOR SHALL BE RESPONSIBLE FOR ANY DAMAGE TO ALL UTILITIES.
 DEPTH & LOCATION OF EXISTING UTILITIES SHALL BE FIELD VERIFIED BY THE CONTRACTOR PRIOR TO CONSTRUCTION.

SEE DRAINAGE AREA MAP SHEETS FOR DRAINAGE SYMBOLOLOGY.

R/W & U/E PURCHASED UNDER JP 09032(05)

POB & ASSOCIATES, OKLAHOMA CITY, OK.
90% PLAN
SUBMITTAL
 3/4/2024

AREA
 CUT FILL

VOLUME
 CUT FILL

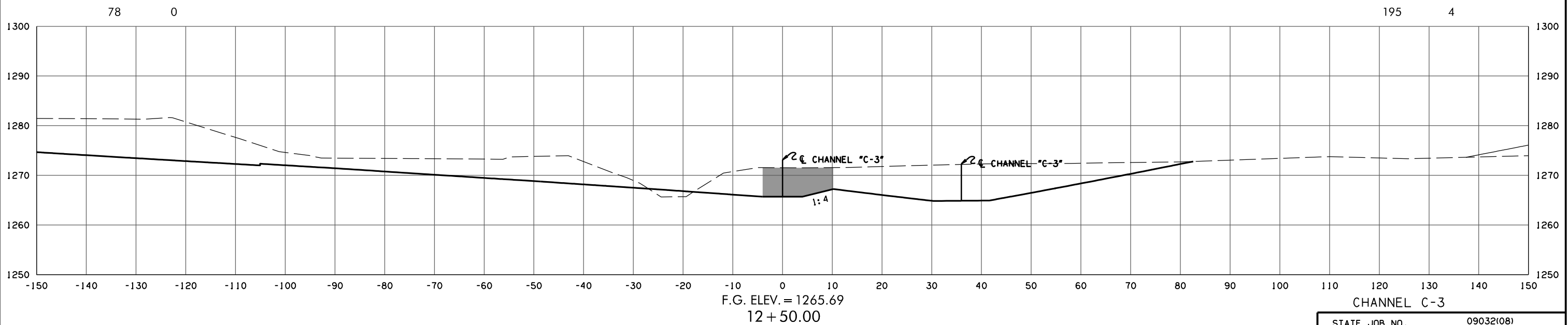
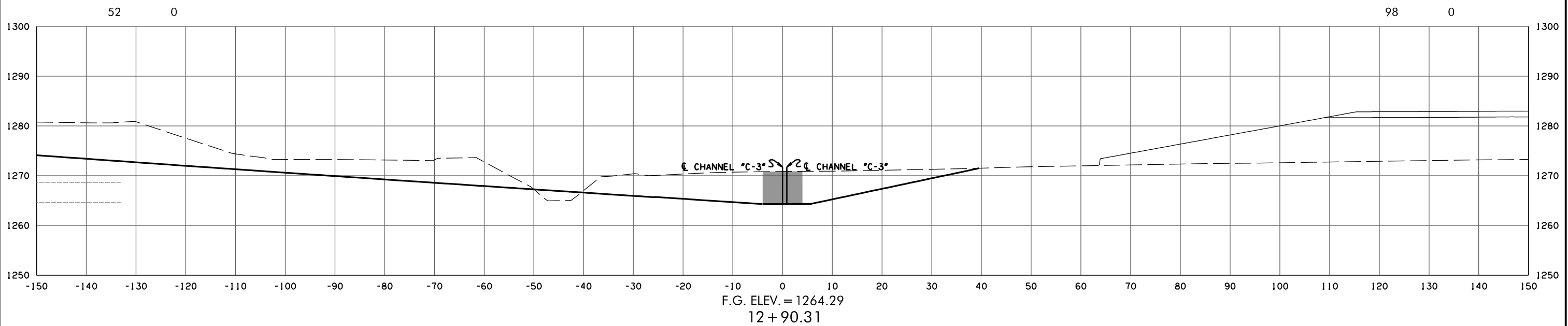

CHANNEL C-3

STATE JOB NO. 09032(08)
 OKLAHOMA COUNTY SHEET NO. X313

3/4/2024 4:00:07 PM H:\PROJECTS\2789_CrossRoads_Phase 4\Roadway\Drawings\Sections\0903208-XSEC.CHANNEL C-3.dgn